

CR 115508

2  
m 18

**SPACE  
DIVISION**

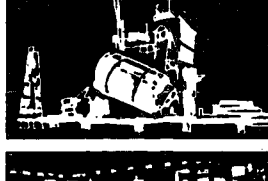
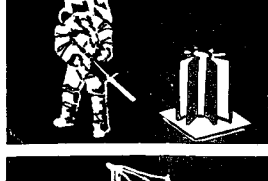
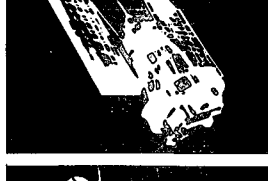
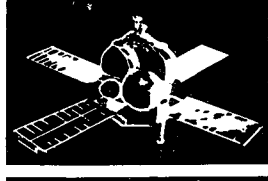
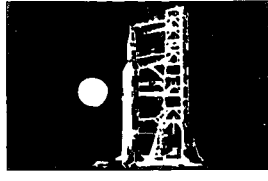
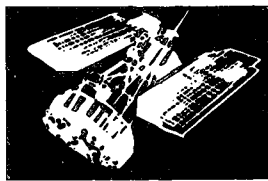

**GE NO. 70SD5414**

(NASA-CR-115508) **PRESSURE RAMP PROGRAMMER;** N72-21074  
[IMBLMS PHASE B4 ADDITIONAL TASKS: **TASK 3.0**  
**PRESSURE RAMP PROGRAMMER Final Report**  
S.L. Fogal, et al (General Electric Co.) **Unclas**  
Jan. 1972 81 p **CSC L 06B G3/05 23178**

# IMBLMS PHASE B4

## ADDITIONAL TASKS TASK 3.0

### Pressure Ramp Programmer FINAL REPORT

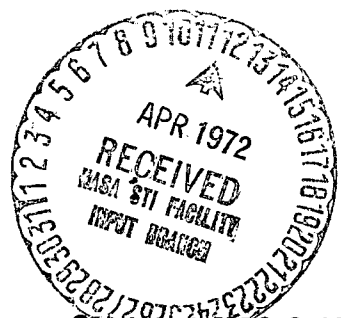
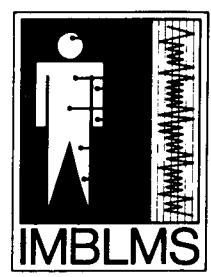

**Contract NAS 9-10741  
Phase B4**

Reproduced by  
**NATIONAL TECHNICAL  
INFORMATION SERVICE**  
U S Department of Commerce  
Springfield VA 22151

**GENERAL  ELECTRIC**

CAT. 05

GE NO. 70SD5414  
JANUARY, 1972

FINAL REPORT  
ON  
TASK 3  
PRESSURE RAMP PROGRAMMER

CONTRACT NAS9-10741

PREPARED BY: G. L. FOGAL  
C. G. REINHARDT

GENERAL ELECTRIC CO.  
SPACE DIVISION  
VALLEY FORGE SPACE CENTER  
P.O. BOX 8555  
PHILADELPHIA, PA. 19101

## TABLE OF CONTENTS

Section		Page
1	SUMMARY	1
2	BACKGROUND	2
3	SYSTEM DEFINITION	3
3.1	Design Requirements	3
3.2	Description and Operation	6
3.2.1	Description	6
3.2.2	Operation	10
4	EQUIPMENT DESCRIPTION	12
4.1	Valving	12
4.1.1	Bleed Valve	12
4.1.2	Dump Valve	12
4.1.3	Fill Valve	16
4.1.4	Relief Valve	16
4.1.5	Calibration Valve	16
4.2	Pressure Sensor	16
4.3	Pump Reservoir	17
4.4	Controller	19
4.4.1	Principles of Operation	19
4.4.2	Signal Inputs	21
4.4.3	Outputs	23
4.5	Signal Conditioner	24
4.5.1	Analog Pressure Output	24
4.5.2	Fill Pressure Output	24
4.5.3	Pressure Relief Output	25
4.5.4	$\Delta$ Pressure Output	25
4.5.5	$P < 30$ Output	26
4.5.6	Calibration Circuits	26
4.6	Power Conditioning	27
4.6.1	+ 15 VDC Power Supply	27
4.6.2	+5 VDC Logic Power Supply	27
4.6.3	+5 VDC Stepper Motor Power Supply	27
5	SYSTEM TEST RESULTS	28
5.1	Objective	28
5.2	Scope	28
5.3	Procedure	28
5.3.1	Operability Checkout	28
5.3.2	Simulated Blood Pressure Monitoring Test	29
5.4	Results	31
5.4.1	Operability Checkout	31
5.4.2	Simulated Blood Pressure Monitoring Test	31

TABLE OF CONTENTS (cont'd)

<u>Section</u>		<u>Page</u>
6	RECOMMENDATIONS	40
7	APPENDICES	41
7.1	Requirements Specification	41
7.2	List of Drawings	62
7.3	Operating Instructions	63
7.4	Cycle Time Analysis	65
7.5	List of Component Data Sheets	78

## 1.0 SUMMARY

A Pressure Ramp Programmer Engineering Model was designed, fabricated and tested. This Engineering Model, in conjunction with an automatic Blood Pressure Monitor, automatically controls the pressure in the Blood Pressure Monitor arterial cuff. The cuff pressurization cycle is designed to maximize accuracy and repeatability of blood pressure measurements.

The key feature of this automatic cycle is rapid blood pressure cuff bleed down from an initial setting until systolic (diastolic) pressure is encountered followed by a short repressurization and slow bleed, long enough to permit accurate systolic (diastolic) pressure determination.

The system includes a pressure reservoir which bleeds the cuff through a precision needle valve. This valve is driven by a stepper motor for bleed rate control. A solenoid valve permits rapid pressurization from the reservoir. A pressure sensor provides information for bleed rate and set point controls. Korotkoff sound signals from a microphone in the blood pressure cuff (not part of the system) provide decision information to the digital control system.

The system completed a series of engineering tests using simulated Korotkoff sound inputs. Initial pressure levels, rapid bleed down rates, automatic recycle times, and heart rates were varied. The system performed successfully in all cases was stable over an extended period of time.

It is recommended that a logical next step would be physiological evaluation of the cycle as mechanized in this system.

## 2.0 BACKGROUND

During the IMBLMS Phase B-4 program, the concept of an idealized arterial cuff pressurization cycle was formulated. This cuff pressurization cycle concept was designed for accurate and repeatable blood pressure measurements when used with an automatic blood pressure monitoring system. Figure 2.0-1 illustrates the pressurization cycle. The key feature of the cycle is the rapid bleed down in pressure to a pressure just below systole, a partial repressurization to a pressure value 10 to 20 mmHg above systole and then a slow bleed down for an accurate, repeatable systolic pressure measurement. The same procedure is used at diastole.

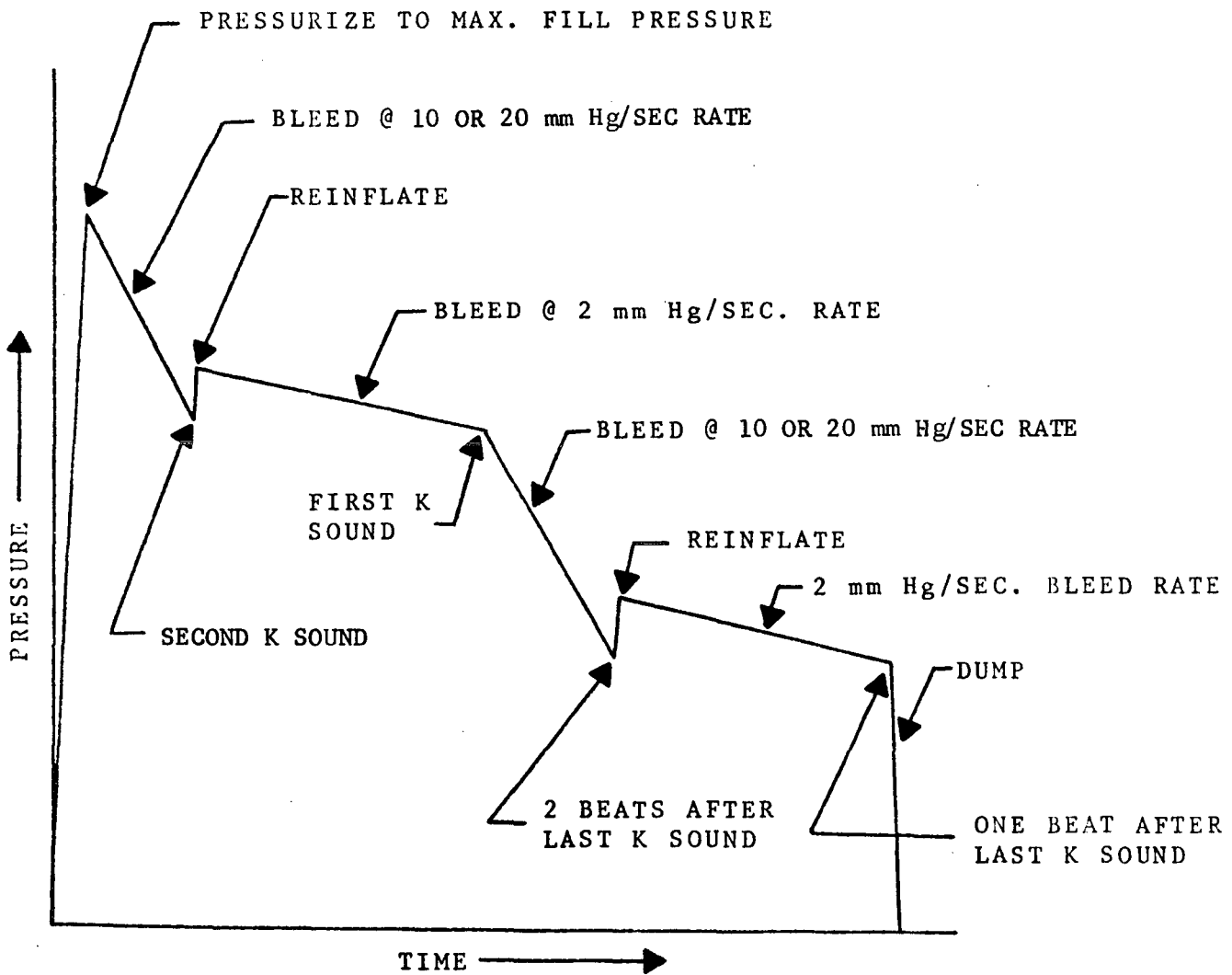

FIGURE 2.0-1. PRESSURIZATION CYCLE (TYP.)

### 3.0 SYSTEM DEFINITION

#### 3.1 Design Requirements

The following excerpt delineates the design requirements as specified in the contract work statement:

"The pressure ramp programmer shall provide the necessary pneumatic equipments and controls to permit automatic fill, bleed down, and dump of an occluding cuff. The programmer shall be configured to consist of one coherent assembly containing the cuff inflation pump (and pressure reservoir if required), cuff pressure transducer and signal conditioner, bleed/dump valves and valve drivers, cycle timer, control logic, and control switches and status indicators. In addition to pressure control, the programmer shall provide an analog output of the cuff pressure. External inputs consist of Korotkoff sounds and heart pulses (ECG wave). Minimum size, weight and power input shall be of secondary importance.

Performance of the pressure ramp programmer shall be as follows: The programmer shall be configured to provide three modes of operation: (1) automatic cycling at 30-second intervals; (2) automatic cycling at 60-second intervals, and (3) manual operation. For the 30-second cycle, the configuration shall be such that cuff maximum fill pressure can be set at any level between 130 and 170 mmHg and the time duration between maximum pressure and dump shall occupy from 20 to 22 seconds to allow at least 8 seconds before onset of next inflation. For the 60-second cycle at least 20 seconds of time shall lapse between dump and onset of the next cycle and the configuration shall be such that maximum fill pressure can be set at any level between 140 and 300 mmHg. For the manual mode, configuration of the programmer shall also allow maximum fill pressure to be set at any level between 140 and 300 mmHg. In all modes, time to maximum fill pressure shall not exceed 1 second, as a goal, and dump shall be to a level between 1 and 3 mmHg.

Bleed time from maximum fill pressure to the third Korotkoff sound shall be rapid (at a rate compatible with programmer cycle interval). At third sound, the programmer shall reinflate rapidly to between 15 and 20 mmHg above the pressure level at which the first K sound occurred. It shall then bleed down more slowly (at a rate compatible with programmer cycle length) to systolic (first K sound). The pressure then drops rapidly to below occurrence of diastolic (last K sound). When sufficient time after the last K sound has lapsed for two additional K sounds to have occurred (e. g.,

2 seconds at a heart rate of 60, or 1 second at a heart rate of 120 beats per minute), the programmer shall reinflate to a pressure 15 to 20 mmHg above the occurrence of the last K sound and bleed down at the previous slow rate. It shall dump to a level of from 1 to 3 mmHg when sufficient time following the last K sound has lapsed to have allowed for two additional K sounds to have occurred. Dump time shall not be greater than 1 second.

A calibration capability shall be provided to furnish calibrating pressures to the pressure cuff in stepwise fashion in increments of 40 mmHg. The maximal calibrating pressure shall be selectable at 160, 200, 240, or 280 mmHg. After reaching the selected maximum calibrated pressure, the programmer shall then provide a stepwise descending pressure in decrements of 40 mmHg. Each pressure level in the calibration cycle shall persist for 5 seconds."

In the course of the design effort, two changes were recommended and approved by NASA.

- (1) In place of cuff maximum fill pressure adjustable to any value between 130 and 300 mmHg, the design will incorporate discrete incremental maximum cuff pressure settings of 130, 150, 170, 200, 230, 260 and 300 mmHg pressure, manually selectable by the operator.
- (2) The design will incorporate two rapid pressure bleed down rates manually selectable by the operator, of 10 and 20 mmHg pressure drop per second plus systole repressurization will be initiated at receipt of the second (rather than the third) K sound. This change in requirements was based on an analysis of the relationship between heart rate, repressurization and cycle time which revealed the following three problems (see also Appendix 7.4):



(a) Occurrence of the third K sound (for initiating pump-up re-pressurization) will not occur if the difference between systolic and diastolic pressures is less than 40 mmHg; i. e., twice the 20 mmHg per second fast bleed down rate. For this "condition", a second "rapid" bleed down rate of 10 mmHg per second could be used. The operator would manually select either a 10 or 20 mmHg per second rate.

An alternate approach is to change the pump-up initiation from the receipt of the third K sound to the second (or first) K sound. Assuming ECG gating is used, the probability of receiving an invalid second (or first) K sound appears low and thus the third sound requirement could be dropped.

(b) Similar to (a) above, a combination of low diastaltic pressure and rapid (20 mmHg per second) bleed down rate can result in cycle termination; i. e., cuff pressure below 40 mmHg pressure. A lower rapid bleed rate, such 10 mmHg per second, would alleviate this difficulty.

The above design requirements are fully reflected in the Pressure Ramp Programmer Engineering Model Requirements Specification, Appendix 7.1.

## 3.2 DESCRIPTION AND OPERATION

### 3.2.1 DESCRIPTION

Figure 3.2-1 is a photograph of the assembled programmer; Figure 3.2-2 is a copy of the system assembly drawing and Figure 3.2-3 illustrates the programmer block diagram. During each pressurization cycle, the air pump is operated for a fixed time period to recharge the reservoir to its nominal operating pressure of 15 psig. Air is supplied to the Blood Pressure Monitor arterial cuff via the solenoid operated fill valve. The bleed valve, a stepper motor operated, 15 turn precision type needle valve, provides constant 2, 10 and 20 mmHg/second pressure bleed down rates. The solenoid operated dump valve drops cuff pressure to ambient at the end of each pressurization cycle or during a cycle in case of an abort condition. A mechanical (spring loaded) pressure relief valve is also attached to the common manifold to prevent inadvertent cuff overpressurization. The pressure sensor provides feedback data to the control logic assembly which in turn sequences the various Pressure Ramp Programmer functions. The controller contains the electronics elements of the programmer including the bleed valve control logic, the bleed valve motor drive, pressure sensor signal conditioner, calibration circuitry and control sequence logic.

A solenoid actuated calibration valve is connected in series with the bleed valve. It operates with the bleed valve open and provides a rapid method of reaching and holding the various calibration pressure levels for the calibration cycle.

The Blood Pressure Monitor arterial cuff connects to the programmer via a quick disconnect coupling located adjacent to the reservoir. Operator controls on the left are selector switches for setting operating mode, maximum cuff fill pressure and rapid bleed rate. On the right are POWER ON/CALIBRATE, START and RESET/ABORT control switches.

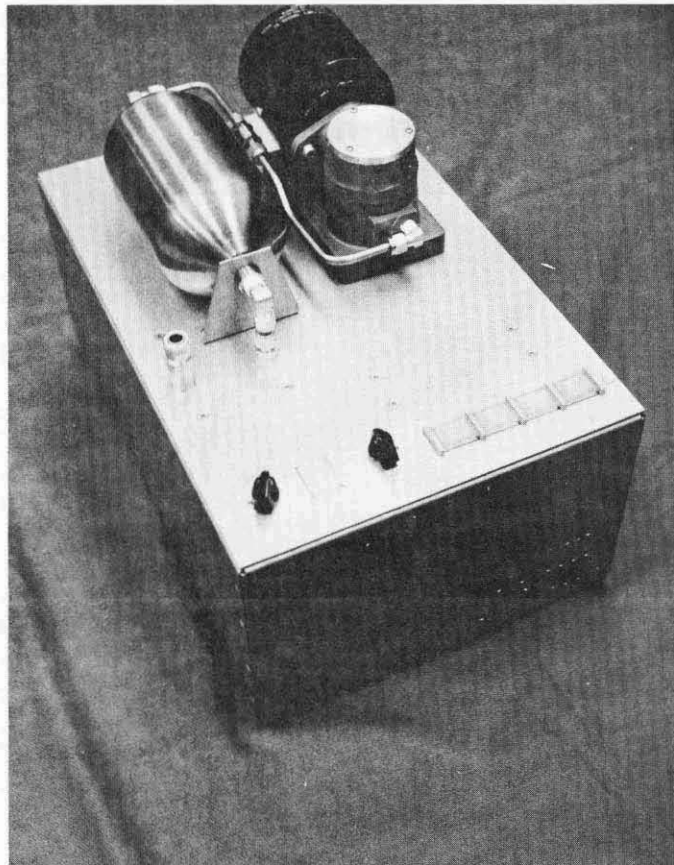

Reproduced from  
best available copy. 

Figure 3.2-1. Pressure Ramp Programmer

FOLDOUT FRAME 1

FOLDOUT FRAME 2

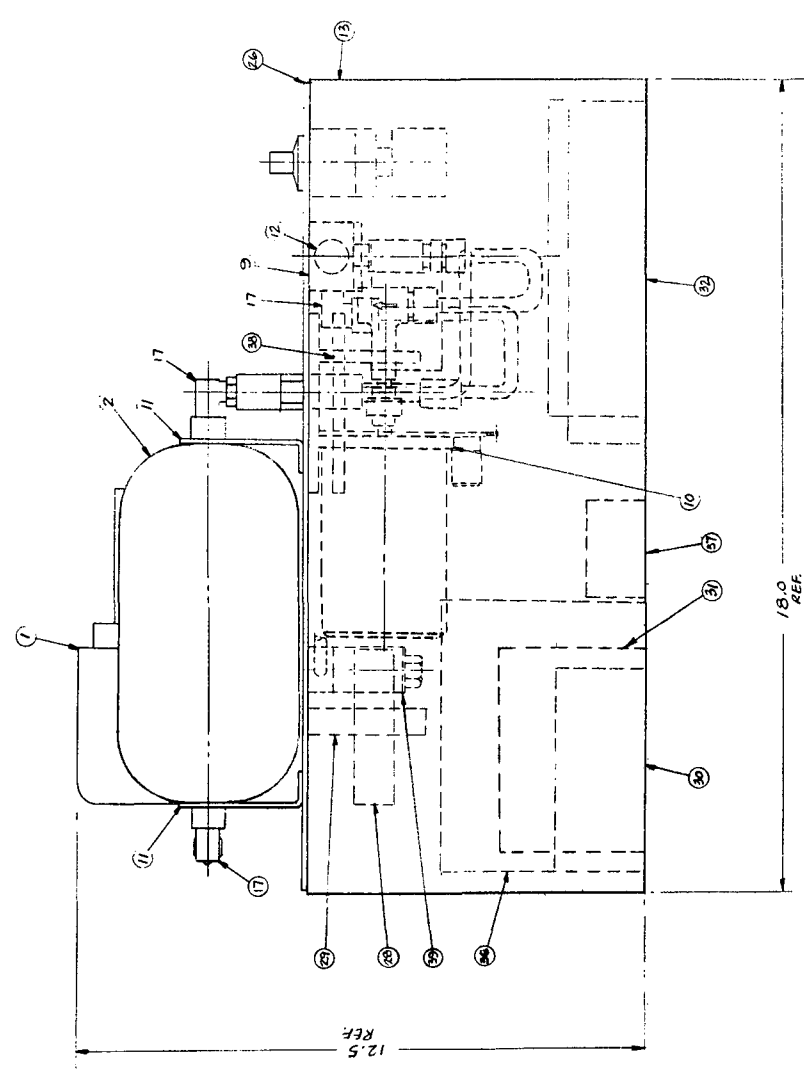
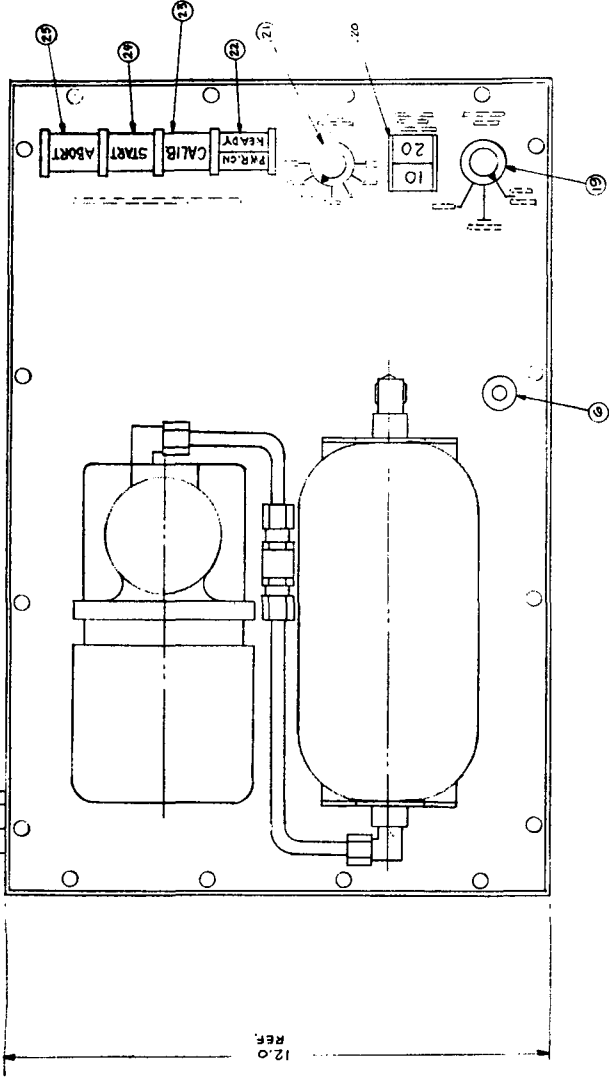

Reproduced from  
 Best available copy.

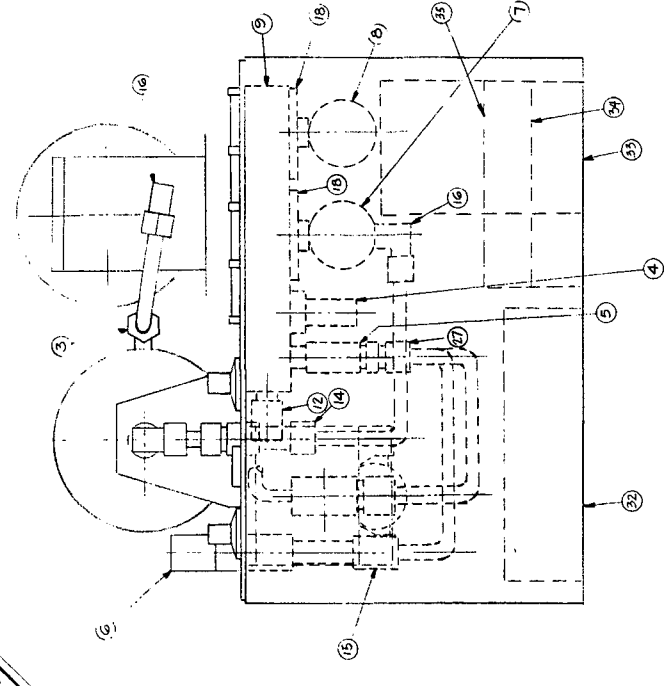

NOTE 5:  
 (A) SWAGELOK CRAMFORD FITTING CO., BOLON, OHIO.  
 (B) 1/8" WT. PORT ELBOW  
 (C) ACDC ELECTRONICS, INC., OCEANSIDE, CALIF.  
 (D) MILKRO SWITCH, FREEMONT, ILL.  
 (E) SKINNER ELECTRIC VALVE, NEW BRITAIN, CONN.

ITEM	IDENT. NO.	DESCRIPTION	LIST OF MATERIAL	NOTE
1	ER47C224774	39 CALIBRATION VALVE		E
1	ER47C224773	38 DRIVER CARD		
1	DEM 5 N 5.7	37 5 VOLT TRACK AND HOLD		C
1	ER47C224769	36 5 VOLT POWER SUPPLY - 5.7 AMPS		
1	ER47C224767	35 ANALOG CARD 3		
1	ER47C224764	34 ANALOG CARD 2		
1	ER47C224765	33 AUGAT BOARD (ALSO DIBS- ER47C224766, T6B, T70 & T71)		C
1	15.1000	32 5 VOLT POWER SUPPLY, SEMICONDUCTOR CIRCUITS, INC., WOBURN, MASS.		
1	CBSD-37-1	30 15 VOLT POWER SUPPLY		
1	ER47C224762	29 RELAY CARD		
1	9904-131-03004	28 8-PHASE ELECTRONIC SWITCH, AM. HAYDEN CO., WATERBURY, CONN.		A
1	400-1-2	27 MALE CONNECTOR		
1	ER47C224716	26 COVER		
1	26-1292/2A70	25 PUSH BUTTON SWITCH BARRIER MT., MOM. ACT. 2 POLE, SINGLE SECT. SCREEN		D
1	26-1292/2A70	24 PUSH BUTTON SWITCH BARRIER MT., MOM. ACT. 2 POLE, SINGLE SECT. SCREEN		D
1	26-1292/2A70	23 PUSH BUTTON SWITCH BARRIER MT., MOM. ACT. 2 POLE, SINGLE SECT. SCREEN		D
1	26-1292/2A70	22 PUSH BUTTON SWITCH BARRIER MT., ACT. ACT. 2 POLE, LOUIS. SPLIT SCREEN		D
1	PA-2001	21 ROTARY SWITCH, CENTRALAB		D
1	26-1292/2A70	20 PUSHBUTTON SWITCH FL. MT., ACT. 2 POLE, 1 LAT. SPLIT SCREEN		
2	PA-2001	19 ADAPTER SWITCH, CENTRALAB		A
3	400-2-4	17 MALE ELBOW		A
1	400-2-2	16 MALE ELBOW		A
1	400-6-4	15 REDUCING UNION		A
1	400-6-1	14 BULKHEAD UNION		A
1	ER47C224715	13 ENCLOSURE		
1	59T-2M-10	12 RELIEF VALVE, CIRCLE SEAL, ANAHEIM, CAL.		
2	ER47B 224711	11 RESERVOIR SUPPORT BRACKET		
1	ER47B 224717	10 BLEED VALVE ASSEMBLY		
1	ER47B 224713	9 MANIFOLD		
1	V51DA 1125	8 TWO-WAY NC SOLENOID VALVE, SKINNER PHC. IND., INC., NEW BRITAIN, CO.		
1	V52DA 1077	7 TWO-WAY NC SOLENOID VALVE, SKINNER PHC. IND., INC., NEW BRITAIN, CO.		
1	600-GC-61	6 QUICK DISCONNECT		A
1	1391	5 FILTER, BROOKS INSTRUMENT DIV., HATFIELD, PA.		
1	230 (6PSID)	4 PRESSURE TRANSDUCER, SETRA-SYSTEMS, INC., MATICK, MASS.		B
1	55-46-1/3	3 NIPRO CHECK VALVE		
1	HPFA-1000-304	2 SAMPLE CYLINDER, WHITEY RESEARCH TOOL CO., EMERYVILLE, CAL.		
1	4920-30	1 DYNA-PUMP MODEL 4-K, S. GELBER AND SONS, INC., CHICAGO, ILL.		

SIGNATURES		DATE	INITIALS	WF
DESIGNED	G. F. 66-A	26	B	71
CHECKED				
DRAWN				
ENG'G	G. F. 66-A	26	B	71
W/G				
MATLS				

UNLESS OTHERWISE SPECIFIED DIMENSIONS ARE IN INCHES - 1-PLACE DECIMALS ± 2-PLACE DECIMALS ± 3-PLACE DECIMALS ± ANGLES ± FRACTIONS ± MATERIAL -	ALL SURF. ✓ REPRODUCED FROM BEST AVAILABLE COPY
---	--

GENERAL ELECTRIC 550 DEPT LOC	PRESSURE RAMP PROGRAMMER ASSEMBLY
SIZE (CODE IDENT NO.) D	ER47D 224 718
SCALE 1/2	SHEET

Figure 3.2-2. System Assembly Drawing

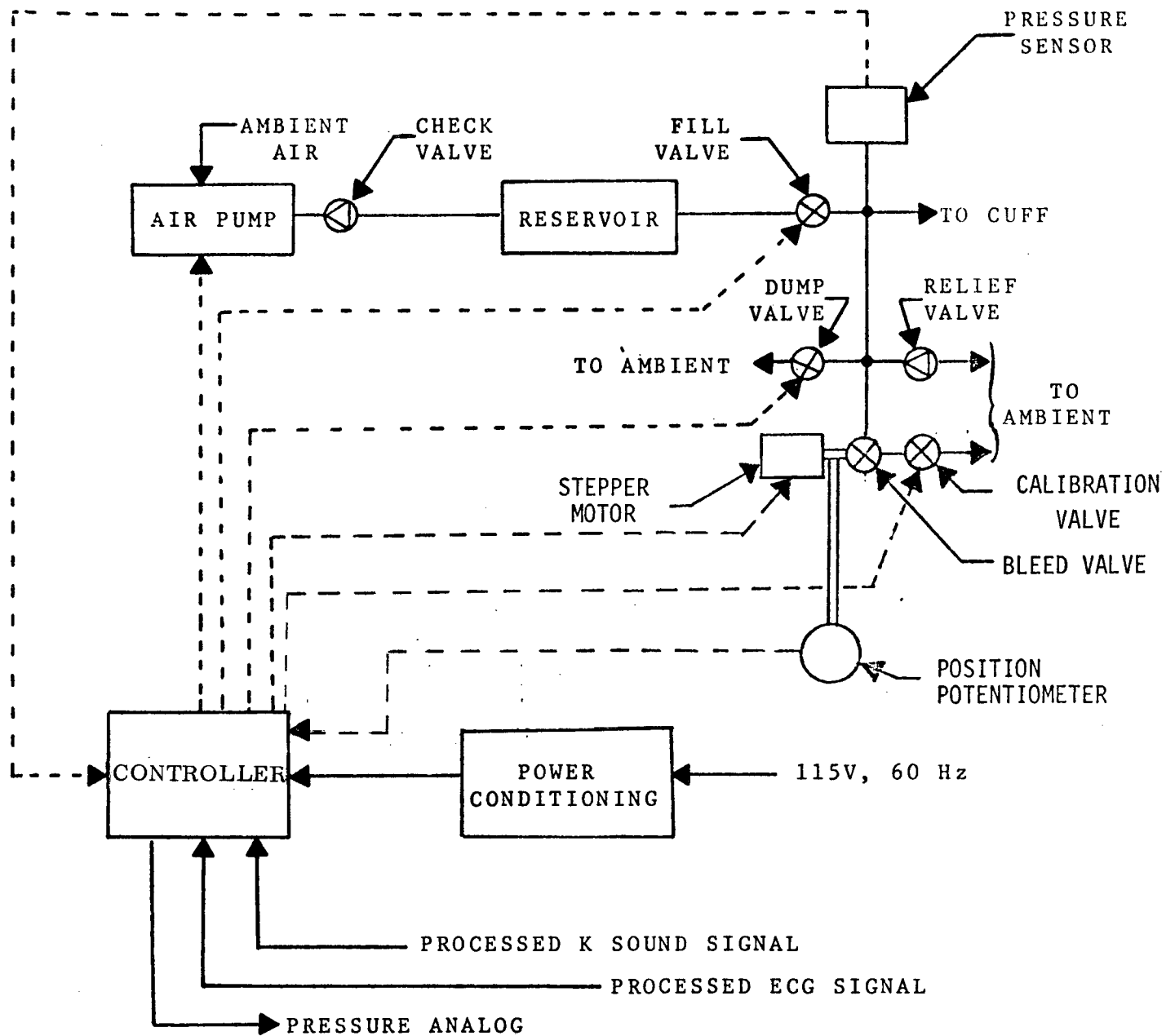

FIGURE 3.2-3. PRESSURE RAMP PROGRAMMER  
ENGINEERING MODEL BLOCK DIAGRAM

### 3.2.2 Operation

3.2.2.1 Start-up (Reference Figure 2.0-1 and 2.2-2 and Appendices 7.1 and 7.3 for additional details.)

Programmer operation is initiated by closing the "POWER ON" switch; a 30 second automatic delay is provided between power on and the time that the unit is ready for operation so that the air pump can fill the reservoir to operating pressure.

#### 3.2.2.2 Calibration

After selecting cycle operating mode, maximum cuff fill pressure and fast bleed down rate, the operator starts the calibration sequence by actuating the "CALIB" switch. This action inflates the cuff to the set cuff fill pressure. The cuff pressure is then automatically reduced in 40 mmHg steps via calibrate valve action with the pressure held at each step for a nominal 5 seconds.

#### 3.2.2.3 Pressurization Cycle

Actuation of the "START" switches initiates the automatic cuff pressurization cycle by opening the fill valve. This action results in rapid (one second) filling of the cuff from the reservoir. The bleed valve is then continuously positioned to provide the desired constant bleed rate based on the pressure sensor feedback output and controller circuitry action. At the receipt of the first K sound, the controller stores the equivalent cuff pressure. At the second K sound, the fill valve is momentarily reopened and the cuff repressurized to a pressure 10-20 mmHg above the pressure stored at the first K sound. Simultaneously, the bleed valve is readjusted to a 2 mmHg per second bleed rate. This slow bleed

rate is the key to accurate and repeatable blood pressure measurements. (The figure at 2mm per second is based on the cycle as developed in Phase B4, and is compatible with the overall cycle requirements of 3.1). At the receipt of the first K sound, the fast bleed rate is again initiated. In a manner analogous to the systolic blood pressure determination above, 2 heart beats after the occurrence of the last K sound, the valve is again re-opened to repressurize the cuff to a pressure 10-20 mmHg above the pressure prevailing at the receipt of the last K sound. Simultaneously, the bleed valve is readjusted to the 2 mmHg/sec bleed rate. Cuff pressure is then dumped via the dump valve one heart beat after the receipt of the last K sound or if the cuff pressure decays to 40 mmHg, whichever occurs first. If the operating mode is set on 30 or 60 second recycling, the pressurization cycle is automatically repeated. If in the manual mode, the operator must actuate the "START" switch to initiate a new cycle.

#### 3.2.2.4 Abort

The pressurization cycle may be terminated at any time by actuation of the "RESET/ABORT" switch by the operator. The cycle will also be terminated automatically if the cuff pressure exceeds a preset value, 350 mmHg, if set cuff pressure is not attained in 5 seconds, or if the cuff pressure drops below 40 mmHg. The next cycle, whether manual or automatic recycling mode, can only be initiated by actuation of the "START" switch after the RESET/ABORT switch has been actuated.

## 4.0 EQUIPMENT DESCRIPTION

### 4.1 VALVING

#### 4.1.1 BLEED VALVE

Figure 4.1-1 is a copy of the Bleed Valve Assembly drawing. The assembly consists of a Brooks Instrument Division Model 8504-6 precision needle control valve driven by a Philips Model PD20 Stepper Motor. Details of these items are shown on the component data sheets, Appendix 7.5. A flexible coupling connects the valve and motor. The assembly is unified by a mounting bracket. A Bourns ten turn pot is mounted to an extension of the bracket and is geared to the motor.

The 15 turn valve (full open to full closed) is sized to provide a controlled bleed flow of 2, 10 and 20 mmHg cuff pressure drop per second for a wide range of cuff pressures. Figure 4.1-2 shows valve controlled air flow as a function of valve turns for a 5 PSID pressure condition. Figure 4.1-3 shows the nominal breakaway torque for the valve as a function of stem position (turns). These values are compatible with the torque-rate characteristics of the stepper motor. In addition to matching the stepper motor with the valve torque requirements, the rate at which the valve is opened and closed is also important. A stepping rate which permits turning the valve stem over its operating range in two seconds was selected as a reasonable and desirable design goal. This relatively high rate is particularly important at the start of each cuff pressurization cycle and at bleed rate change points during the cycle. The high slew rate minimizes transition time when changing bleed rates.

#### 4.1.2 DUMP VALVE

The selection of a dump valve for the Pressure Ramp Programmer is complicated by the wide operating range required. The dump valve must be able to drop cuff pressure to essentially ambient conditions in one second for a cuff pressure range of 40 to 300 mmHg. A Skinner two-way, normally open solenoid valve, model No. V51DA1125 was selected to meet this requirement. For additional details, see component data sheets, Appendix 7.5. The normally open configuration is required so that in the event of power failure, cuff pressure will automatically be vented to ambient conditions.





BROOKS INSTRUMENT DIV.  
MODEL 8504-G MRS NEEDLE  
CONTROL VALVE (15 TURNS)

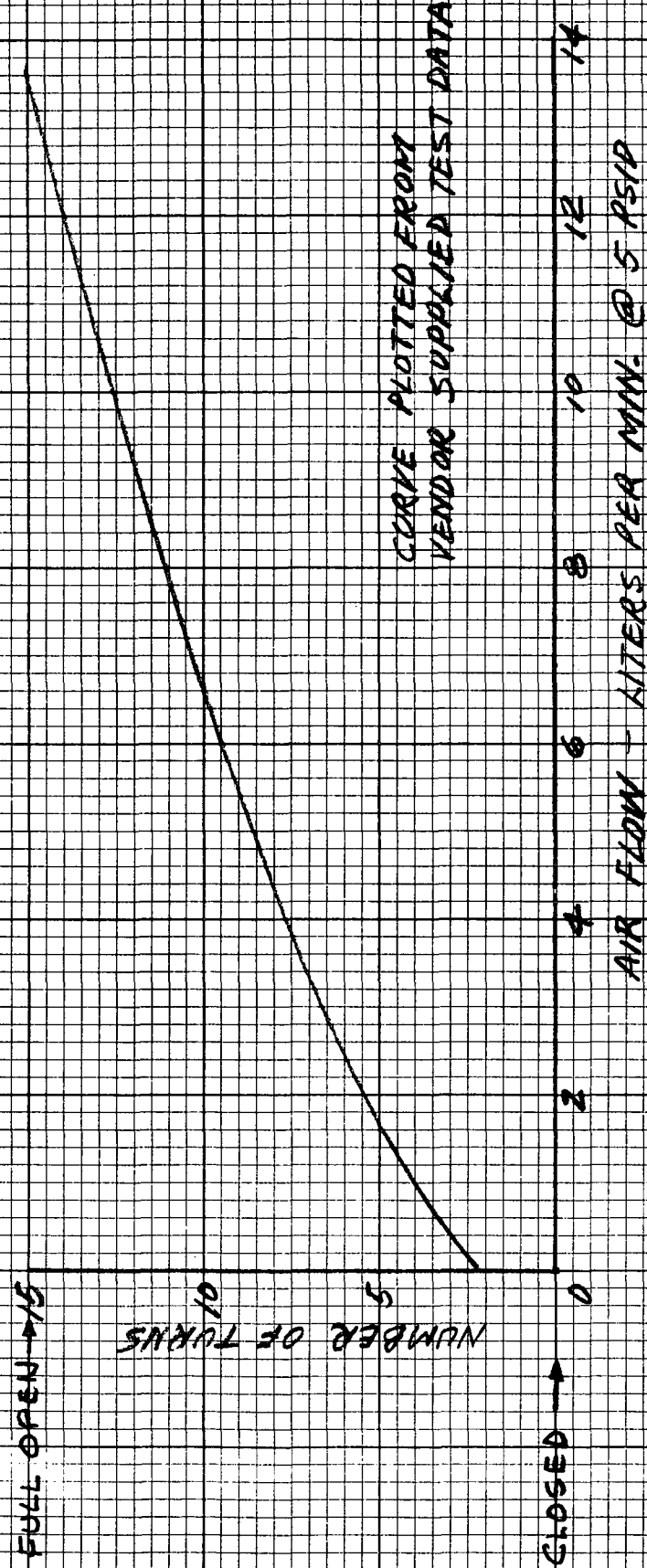

FIGURE 4.1-2 VALVE AIR FLOW (TYP.)

BROOKS INSTRUMENT DIV.  
MOOREL 850A-6 NRS NEEDLE  
CONTROL VALVE (15 TURNS)

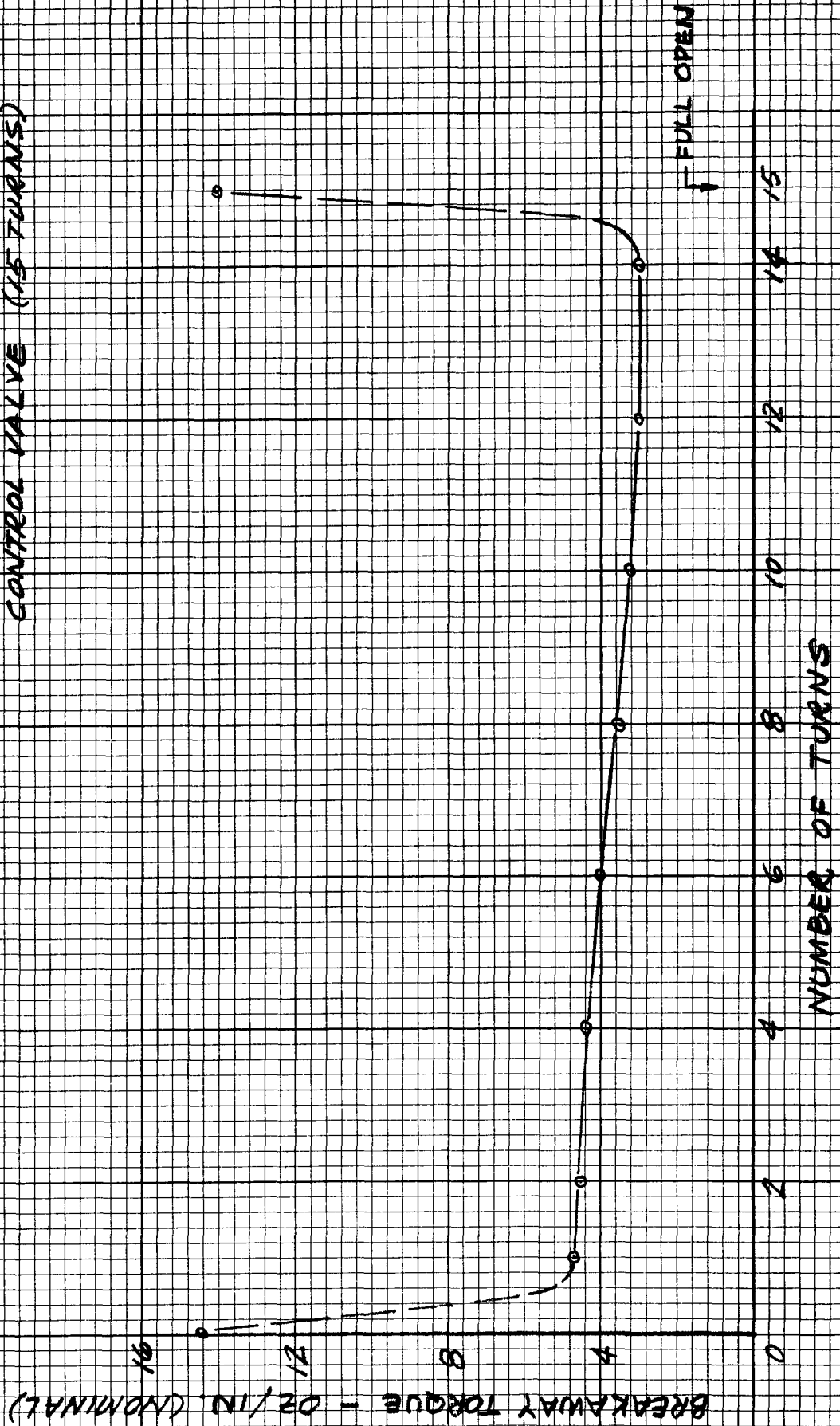

FIGURE 4.1-3 VALVE BREAKAWAY TORQUE

#### 4. 1. 3 FILL VALVE

A Skinner two-way, normally closed solenoid valve, model No. V52DA1077 was selected as the fill valve. This model valve contains an adjustable orifice feature so that the valve can be nominally matched to the cuff volume, reservoir pressure conditions. If the fill valve orifice is too large, cuff pressure will overshoot; if too small, cuff fill time will be greater than one second.

#### 4. 1. 4 RELIEF VALVE

The Circle seal pressure relief valve, model 559T-2M-107 has been set to open at cuff pressures exceeding 350 mmHg. When the pressure drops below this valve, the valve closes. The valve opening pressure is adjustable over a range of 250 to 760 mmHg.

#### 4. 1. 5 CALIBRATION VALVE

A Skinner two-way normally open valve, Model No. B1DA1200 was selected as the calibration valve.

#### 4. 2 PRESSURE SENSOR

A Setra-Systems, Inc. Model 230 pressure sensor was selected for use in the Engineering Model. The sensor consists of a thin stretched diaphragm which acts as the movable plate of a variable capacitor. Built-in electronics converts the capacitance changes due to pressure variations into a high level dc output signal. The selected sensor has a full-scale pressure range of 7.0 psid (nominal 1.25 volt output) and can take overpressures to 100 psid.

### 4.3 PUMP/RESERVOIR

The Model 4K DYNA-PUMP is a diaphragm type pump capable of a maximum pressure of 16 psig and having a maximum flow capacity of 600 in<sup>3</sup>/minute. The 1/20 hp, 120 volt, 60 Hz motor drives the pump at 1500 strokes per minute. The low maximum pressure is not consistent with minimum weight and volume considerations but does provide inherent subject and equipment safety as compared to a high pressure air source.

The reservoir is a 1000 ml gas sampling cylinder. This capacity cylinder was selected to assure that the reservoir pressure after initial cuff pressurization is capable of providing for repressurization at systole and diastole. Figure 4.3-1 shows the effect of reservoir volume on reservoir pressure (after an initial cuff pressurization fill volume of 400 ml). The 400 ml value was based on the laboratory test results of Figure 4.3-2.

A Nupro model SS-4C-1/3 check valve, opening pressure 1/3 psi, is placed between the reservoir and air pump. Initial pressurization of the reservoir from ambient to 15 psig, takes about 15 sec., the increase in reservoir pressure being approximately linear with time.

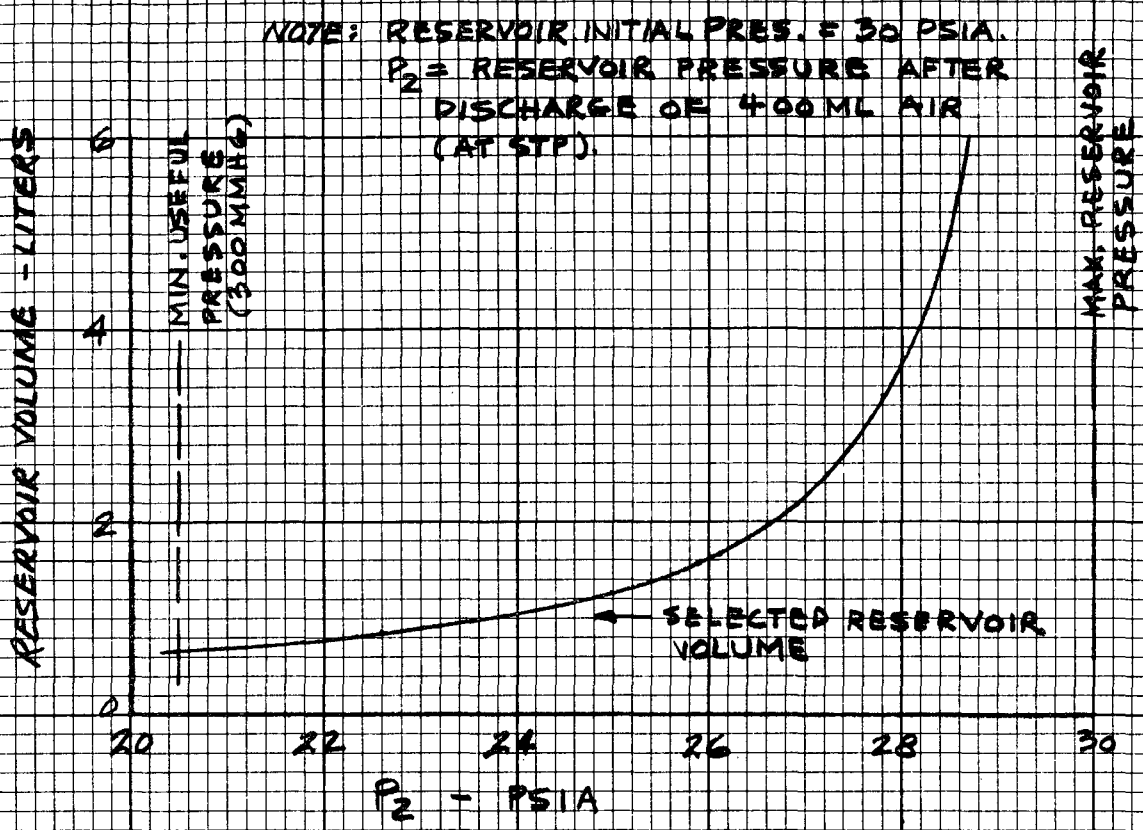

FIGURE 4.3-1 CHANGE IN RESERVOIR PRESSURE

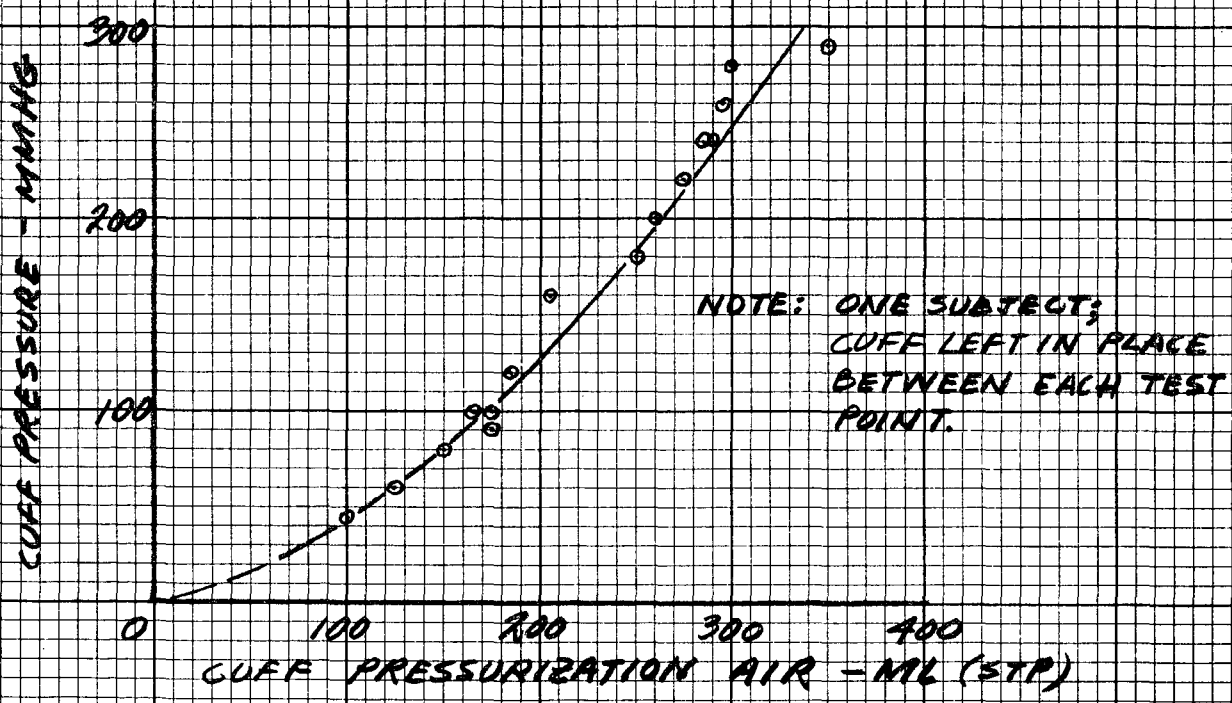

FIGURE 4.3-2 CUFF PRESSURIZATION TEST

## 4.4 CONTROLLER

The control logic for the Pressure Ramp Programmer (PRP) is implemented using series 7400 TTL circuits mounted on a 60 circuit augat board.

### 4.4.1 PRINCIPLES OF OPERATION

The control logic consists of a number of counters that provide the timing and sequencing for the different modes of operation. The A counter provides the eight steps required to make a measurement. The B counter counts down a 4300 Hertz clock to provide all of the timing signals required by the PRP.

The E, F & G counters are used for the calibrate logic. The E counter generates delay and timing signals for overall cycle control, the F counter generates the pulses of the counting down of the G counter that drives the D/A converter. The calibrate logic was originally designed to use the bleed valve but it was determined that the response of the stepping motor was not adequate for the function and the calibrate valve was added for the calibrate function. Consequently, the present logic is more complex than is now necessary and could be simplified if redesigned.

#### 4.4.1.1 CALIBRATE MODE

The Calibrate Valve is normally open and in series with the bleed valve. The bleed valve is opened during the first part of the calibrate operation. At the start of a calibrate cycle, the bleed valve is opened and the cuff filled to the preselected maximum pressure. When the predicted pressure is reached, the D/A counter is set to all "ones" and then counted down until

the D/A output is equal to the output of the cuff pressure transducer. At this time, the delay counter is enabled and after a 5 second delay, the D/A counter is counted down 8 counts (40 mmHg equivalent) and the calibrate valve is opened to bleed down the cuff pressure until the D/A output and the pressure transducer output are again equal. This process continues until the count in the D/A counter is less than eight at which time the process is terminated. The results of the process are a series of pressures starting at the preselected program where each successive step is 40 mmHg lower and the pressure at each step is maintained for  $5 \pm 1/2$  seconds.

#### 4.4.1.2 Measurement Mode

In the mode which has three submodes, a manual, 30-second repeat and 60-second repeat, the start switch sets the run FF which is reset at the end of one measurement cycle in the manual submode or by the reset switch to terminate the repeat submodes. Actuation of the start switch also resets the B-counter (30-60 second times) and clocks the sequence start FF. The setting of the sequence start FF enables the A counter to step to state "1" which enables the filling of the cuff. When the preselected maximum pressure is reached, the counter steps to state "2" which starts the fast bleed down rate. The A counter continues to sequence through the remaining steps in the measurement cycle as depicted in Figure 3.1.1-1, unless interrupted by an abort condition or the actuation of the reset or power switch. At the end of each cycle, the reservoir pump is turned on for  $\sim 5$  seconds. Initial application of power or actuation of the reset switch turns on the reservoir pump for 19 seconds.



#### 4.4.1.3 Bleed Valve Control

The bleed down rate is controlled by sampling the output of the  $\Delta P < 2$  and the  $\Delta P < 20$  comparator every 62.5 milliseconds. Depending on the comparator output and the portion of the measurement cycle the PRP is in, the bleed valve is drawn open or closed until the next sample. The valve is always driven closed during initial cuff fill and both refill parts of the measurement cycle.

#### 4.4.1.4 K-Sounds Sensing

The K-sound counter consists of two J-K FF's;  $FF_1$  is set by the first K-sound received and  $FF_2$  is set by the second K-sound received. Both are reset by the maxpress or  $\Delta$  pressure signals. The first missing K-sound is detected by a time delay from the ERC signal; if the timer times out it is assumed the first missed sound occurred. When the next EKG sound is detected, it is assumed the second missed K-sound has occurred.

#### 4.4.2 SIGNAL INPUTS

Logical one inputs are provided for  $\Delta PC < 2$  mmHg/sec and  $\Delta P < 10$  (20) mmHg/sec. These inputs are derived in the following fashion. A track and hold amplifier (ER47C224773) samples and holds the analog pressure for a fixed time interval (62.5 ms) upon command from the control logic. The analog pressure is subtracted from the track and hold output and amplified (A1-card 2). Pot R21 (A1) located on card 2 adjusts the baseline on  $\Delta P$  amplifier. Adjusting this pot will cause a change in the resulting bleed down rate. The output of this amplifier is fed to two comparators. The first of these is set so that its output is high (logical "1") whenever the

difference between the held value and the analog pressure is less than the amount the pressure would have changed in 62.5 ms if the bleed rate were 2 mmHg/sec. Whenever the difference exceeds this predetermined value, a logical "0" is presented at this comparator's output. The second comparator is set so that it presents a logical "0" if the difference is less than what it would have been if the bleed rate were 10 mmHg/sec (20 mmHg/sec - selectable by front panel switch) and a logical "1" if the difference exceeds this predetermined value. The output of these two comparators is shown diagrammatically in Figure 4.4-1.

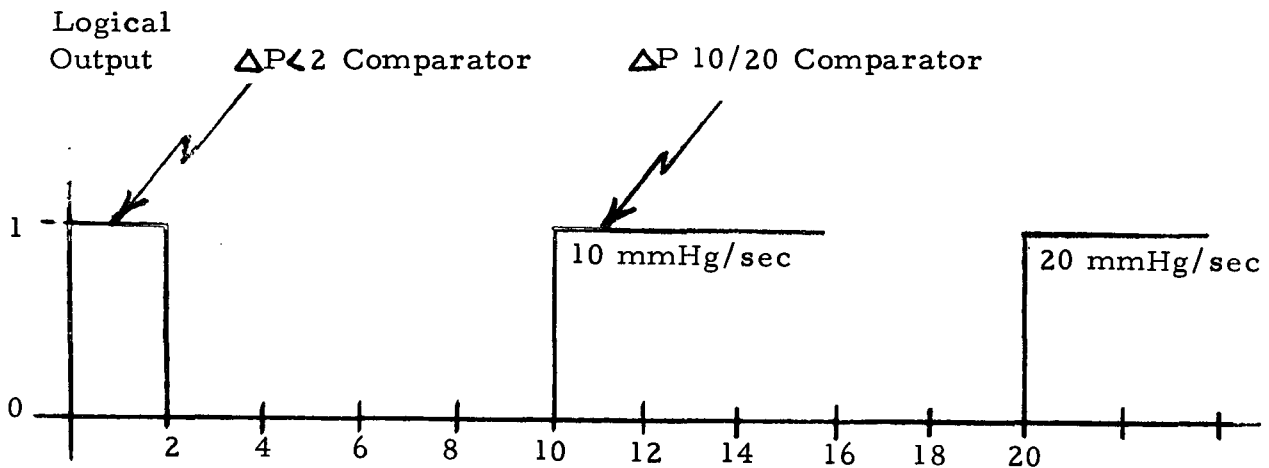

Figure 4.4-1. Comparator Outputs

In addition to bleed rate information, the controller also requires preprocessed K-sound and heat information (see Appendix 7.1, Section 3.2). These signals are provided to the unit through pins a. (heart beat) and u (K-sound) on Connector J2.

#### 4.4.3 OUTPUTS

The bleed valve control logic provides a digital signal to the stepper motor driver card which controls the direction of rotation of the bleed valve. A second output from the bleed valve control logic provides the pulses which cause the stepper motor to step. The actual driving current to the motor itself is provided by the stepper motor driver card.

The control logic also provides signals, which are brought out on Connector J2, when the first K-sound occurs the second time (J2-D) and when no sound occurs the second time (J2-C). These signals, when presented on a strip chart recorder along with the pressure analog (available on J2-W), enable a determination of blood pressure to be made.

## 4.5 SIGNAL CONDITIONER

### 4.5.1 ANALOG PRESSURE OUTPUT

The output of the Setra Systems Model 230B is scaled for -10.0 volts for 300 mmHg input pressure using an LM208A operational amplifier connected in a differential configuration and having a fixed gain of 9.31. A potentiometer, R21 (Card 1), is provided to adjust the output to zero for zero pressure.

The output of this amplifier is inverted to a 0 to +10.0 volt output by amplifier A2 on card 3 to provide an external analog pressure output. Potentiometer R6 on card 3 allows the gain of this amplifier to be adjusted to exactly +10.00 volts for 300 mmHg.

Also on card 1 there is an LM304 voltage regulator designed to provide  $-6.000 \pm .010$  volts DC from the -15VDC supply to provide excitation for the transducer. Potentiometer R5 (card 1) allows this voltage to be precisely set.

### 4.5.2 FILL PRESSURE OUTPUT

The cuff fill pressure is determined by the setting of the cuff fill selector switch located on the front panel. This switch places the output of a resistor divider chain into a comparator (A4 card 1). The conditioned analog pressure signal is also fed to the same comparator. When the cuff pressure exceeds the cuff fill set pressure, an output is provided to the control logic which in turn de-energizes the fill valve. To insure immunity against possible noise on the pressure line and hence multiple signals to the fill valve, hysteresis

has been included in the comparator design. The amount of hysteresis can be adjusted using R25 (card 1).

#### 4.5.3 PRESSURE RELIEF OUTPUT

To insure that cuff pressure never exceeds 320 mmHg, the conditioned analog output voltage is fed to another comparator (A5 card 1) whose reference is set to approximately 10.6 volts. The reference voltage is adjustable using potentiometer R19 on card 1. A logical "0" from this comparator tells the control logic to ABORT.

#### 4.5.4 ▲ PRESSURE OUTPUT

The conditioned analog pressure is stored in a track and hold amplifier (A1 card 1) upon command from the control logic. The hold condition is activated by the first K-sound and again with the first beat without an associated K-sound. The stored pressure signal provides one input to a comparator (A4 card 2). This comparator also receives the conditioned analog pressure signal and an adjustable (potentiometer R29 card 2) reference voltage. When the difference between the held pressure and the analog input pressure exceeds the reference voltage, a logical "1" output is provided to the control logic to stop the systolic and diastolic repump.

#### 4.5.5 P<30 OUTPUT

If for some reason the programmer does not complete its cycle, a command is generated by the P<30 comparator (A3 card 3) which tells the control logic to ABORT. Comparator A3 accomplishes this action by comparing the positive-going analog pressure output from A2 (card 3) and a set voltage reference. This voltage reference is determined by a fixed resistor divider from -15 VDC.

#### 4.5.6 CALIBRATION CIRCUITS

The output of the calibration shift register is fed in parallel to a Varadyne Model DAC-HB8B D/A converter located on card #2. The output of the D/A converter provides the reference voltage to one side of comparator A1 on card #3. The other side of the comparator is fed with the analog pressure signal generated by A2 on the same card. When the pressure is less than the D/A voltage, a logical one signal is fed to the control logic.

## 4.6 POWER CONDITIONING

The Pressure Ramp Programmer operates from 115 VAC 60Hz, single phase primary power. The power input line is fused for protection of the equipment. Internal power supplies provide the necessary operating voltages.

### 4.6.1 + 15 VDC POWER SUPPLY

The + 15 VDC power supply is an AC/DC Model CD15D.37 CAPABLE OF PROVIDING up to .37 amperes and having a regulation (line and load) of better than .1%. The supply is short-circuit protected.

### 4.6.2 +5 VDC LOGIC POWER SUPPLY

The +5 VDC necessary to operate the digital control logic is a Semiconductor Circuits Model 1.5.1000. This unit can supply up to 1.0 ampere and is short-circuit protected.

### 4.6.3 +5 VDC STEPPER MOTOR POWER SUPPLY

The power supply used to provide the +5 VDC necessary to operate the bleed valve stepper motor is supplied by an AC/DC Model OEM5N5.7. This unit is capable of supplying 5.7 amperes.

## 5.0 SYSTEM TEST RESULTS

### 5.1 OBJECTIVE

System level engineering dheckout tests were conducted to determine that the engineering model satisfies the specified design requirements.

### 5.2 SCOPE

After completion of operability checkout, including calibrate cycle, simulated blood pressure monitoring tests were performed to assess correctness and consistency of operation (i. e. , cuff pressure for a given setting, cuff inflation time, bleed down rates, repressurization increments, cuff pressure dump time, response to external K-sound and ECG trigger inputs) for various operating conditions.

### 5.3 PROCEDURE

#### 5.3.1 OPERABILITY CHECKOUT

The unit was checked for leaks, the components adjusted, calibration was checked and the operational sequence was verified.



### 5.3.2 SIMULATED BLOOD PRESSURE MONITORING TEST

Engineering tests were run using the test set-up of Figure 5.3.2-1. The simulator sound and ECG input signals operate as follows:

The square wave output of a signal generator clocks two flip-flops; one on the rising edge of the input signal and the other on the trailing edge. This yields two square waves at half the frequency of the input signal and  $90^\circ$  out of phase with each other. These signals are gated to form two 25% duty cycle square waves. The first is used to simulate the ECG signal and the second ( $90^\circ$  delayed) stimulates K-sound signal. The latter is gated on when the pressure in the cuff is above a selectable diastolic level and below a selectable systolic level as determined by the output of two comparators.

#### 5.3.2.1 Automatic Operation: 30 Second Cycle

Initial cuff pressure settings of 130, 150, and 170 mmHg were selected together with 20 mmHg/second rapid bleed rate. Heart rate was 75 beats per minute. After the manual tests of 5.3.2.3 below, the 150 mm cuff pressure runs were repeated to look for drift. Each cycle was run twice and recorded on the strip chart recorder.

#### 5.3.2.2 Automatic Operation: 60 Second Cycle

Initial cuff pressure settings of 150, 170, 230, 260, and 300 mmHg were selected with 10 mmHg/second rapid bleed down rate. Again, heart rate was 75 bpm, each cycle run twice and recorded on the strip chart recorder.

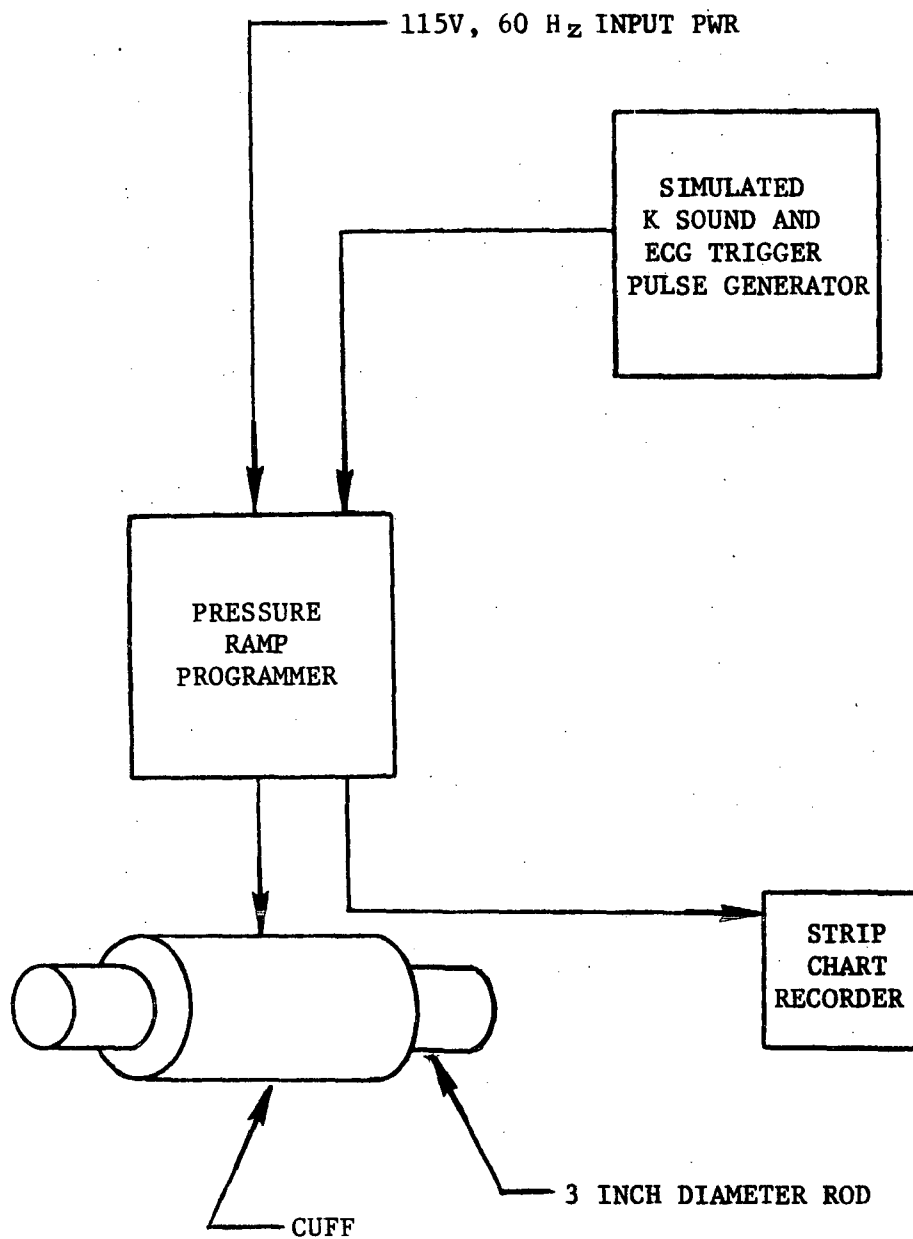

FIGURE 5.3.2-1. TEST SET-UP

### 5.3.2.3 Manual Operation

Cuff pressure settings of 150, 230, and 300 mmHg were used, first with 10 mm/second and then with 20 mm/second rapid bleed down rate. Two runs each were made. Then, with cuff pressure setting of 170 mmHg and rapid bleed rate of 10 mm/second two runs were made with heart rate of 60 bpm and two with 120 bpm.

## 5.4 RESULTS

### 5.4.1 OPERABILITY TEST

Figure 5.4-1 shows a calibration cycle with 40mm pressure steps and 5-second holds at each level.

### 5.4.2 SIMULATED BLOOD PRESSURE MONITORING TEST

Figures 5.4-2 through 5.4-5 show typical strip chart recordings from the more than 30 cycles run and recorded. Analysis of all these records indicates the following:

- (a) **General Characteristics:** The recorded pressure cycles conform reasonably to the overall shape of the idealized cycle as defined previously in Figure 2.0-1. Because of valve control cycling, some waviness of pressure curve is visible, together with a non-critical amount of non-linearity. The most pronounced variation from the idealized curve is the existence of a "pip" at the end of each fill cycle with a short exponential pressure decay before the linear bleed rate is established. This is due to the fact that the bleed valve, which has been opening for fill, must now be mostly closed to establish the bleed rate. This process takes a finite time and, because the valve position is not the same each time, is somewhat variable within a band of 8 to 15 mmHg on initial pump

and 15 to 20 mmHg on repumps to establish desired bleed rate.

- (b) **Bleed Rates:** The 2mm/second nominal bleed rate, as adjusted for the testing, was within a band of 2 1/2 to 3 1/2 mm/second to the accuracy with which slopes could be determined. No trend or drift was noted over an extended period. The 10 mm/second fast bleed rate ran 8 to 10 mm/second and the 20mm/second rate ran 17 to 19 mm/second. Again no trends or drift were noted.
- (c) **Fill Pressures:** Initial fill pressure exhibited an overshoot of about 8 to 15 mm above the nominal value. Repump overshoot was fairly consistent at about 15mm above the 20mm nominal. This overshoot and the initial exponential delay discussed in (a) above were largely offsetting effects.
- (d) **Cycle Duration:** Cycle durations were variable, depending on such factors as the initial fill pressure versus systolic, the pressure drop in establishing initial bleed rates after pump-up, and the phasing of K-sounds versus cycle start. (By selection of fill pressures, bleed rates and systolic and diastolic blood pressures, both conformance and non-conformance to the cycle time requirements can be made to occur). The 30-second cycles to be completed within 22 seconds took from 11 to 19.5 seconds (all using the 20mm/second fast bleed rate). The 60-second cycles, to be completed within 40 seconds, took from 27 to 44 seconds (all using the 10mm/second fast bleed rate). Those cycles exceeding 40 seconds involved initial pressures of 260 and 300 mmHg, far above the systolic pressure used in testing and, thus causing long initial bleed down times.

(e) Fill time, with a target of 1 second, took from 1.3 to 2 seconds depending on maximum pressure setting. (It would be expected that, with the cuff and human arm which is more compliant than the test cylinder, this period would be longer. There is an internal adjustment capability for this. The initial fill rate is chosen to provide fast fill without unacceptable overshoot).

(f) Korotkoff Sound Decisions: Existence or absence of K-sounds from the microphone for system decisions was recorded and was consistent in all cases:

- The decision to repump at systolic was consistently based on two K-sounds.
- The decision to go from slow to fast bleed was consistently based on one K-sound.
- The decision to repump at diastolic occurs consistently at the point of the second absent K-sound and results in a repump which picks up this K-sound.
- The decision to dump at the end of the cycle was consistently based on one absent K-sound.

(This latter case is consistent with planning and previous submissions and discussions, but does not meet specification calling for two absent sounds. This can be changed by a relatively straightforward wiring change, if desired).

- (g) Dump time and pressure: Dump time was consistently about one-half second to a pressure level not discernible on the strip chart.
- (h) Other characteristics: Throughout the final "run for the record" of some two hours, no drifts were observed. Varying the heart rate did not result in any discernible effect on performance.

Pressure  
(mmHg)

Note: Recorder Saturated

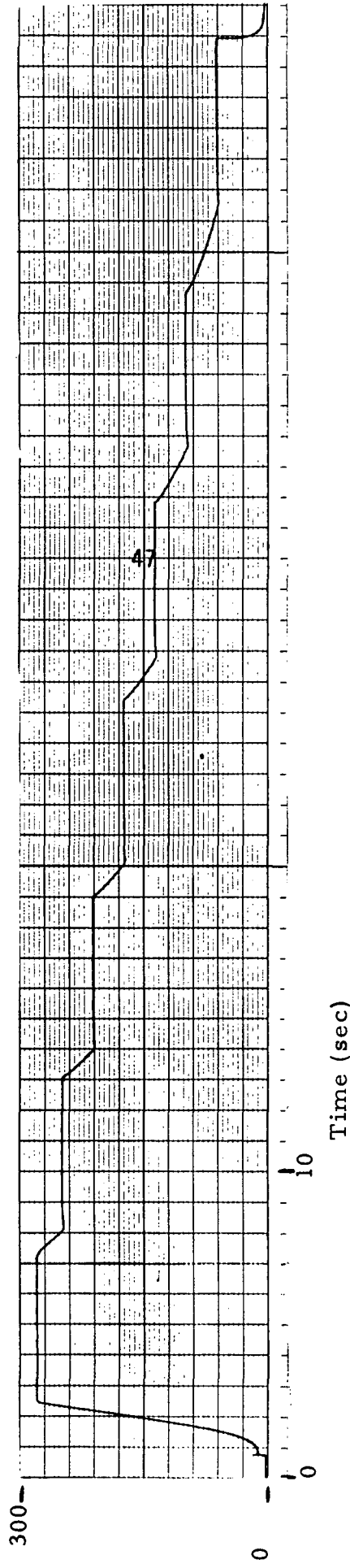

FIGURE 5.4-1. CALIBRATION CYCLE

CYCLE RECORD

- 170 mmHg initial cuff pressure ● 30 second automatic cycle
- 20 mm/sec fast bleed rate ● 75 bpm heart rate

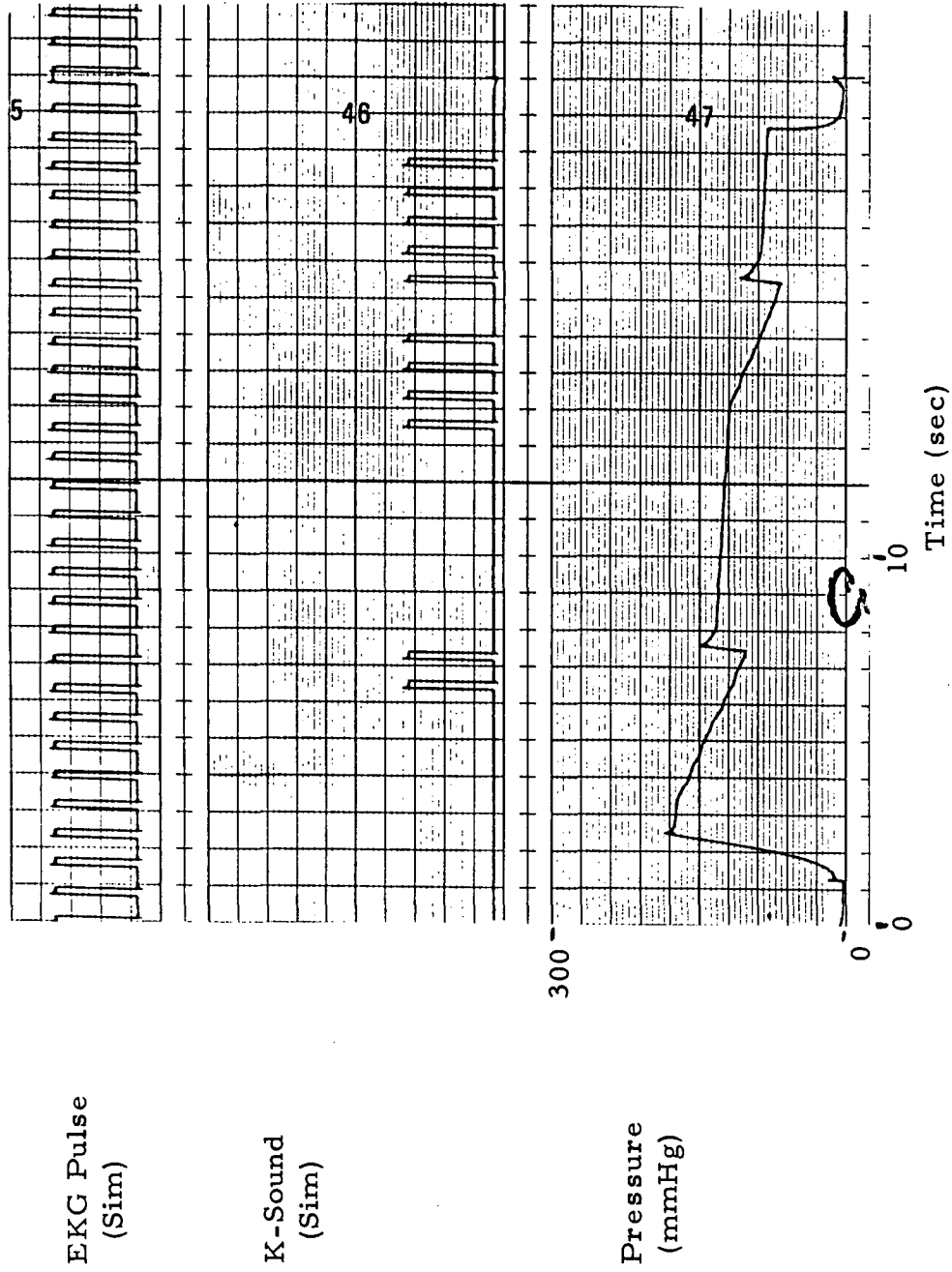

FIGURE 5.4-2



CYCLE RECORD

- 170 mmHg initial cuff pressure
- 20 mm/sec fast bleed rate
- Manual/Recycle
- 60 bpm heart rate

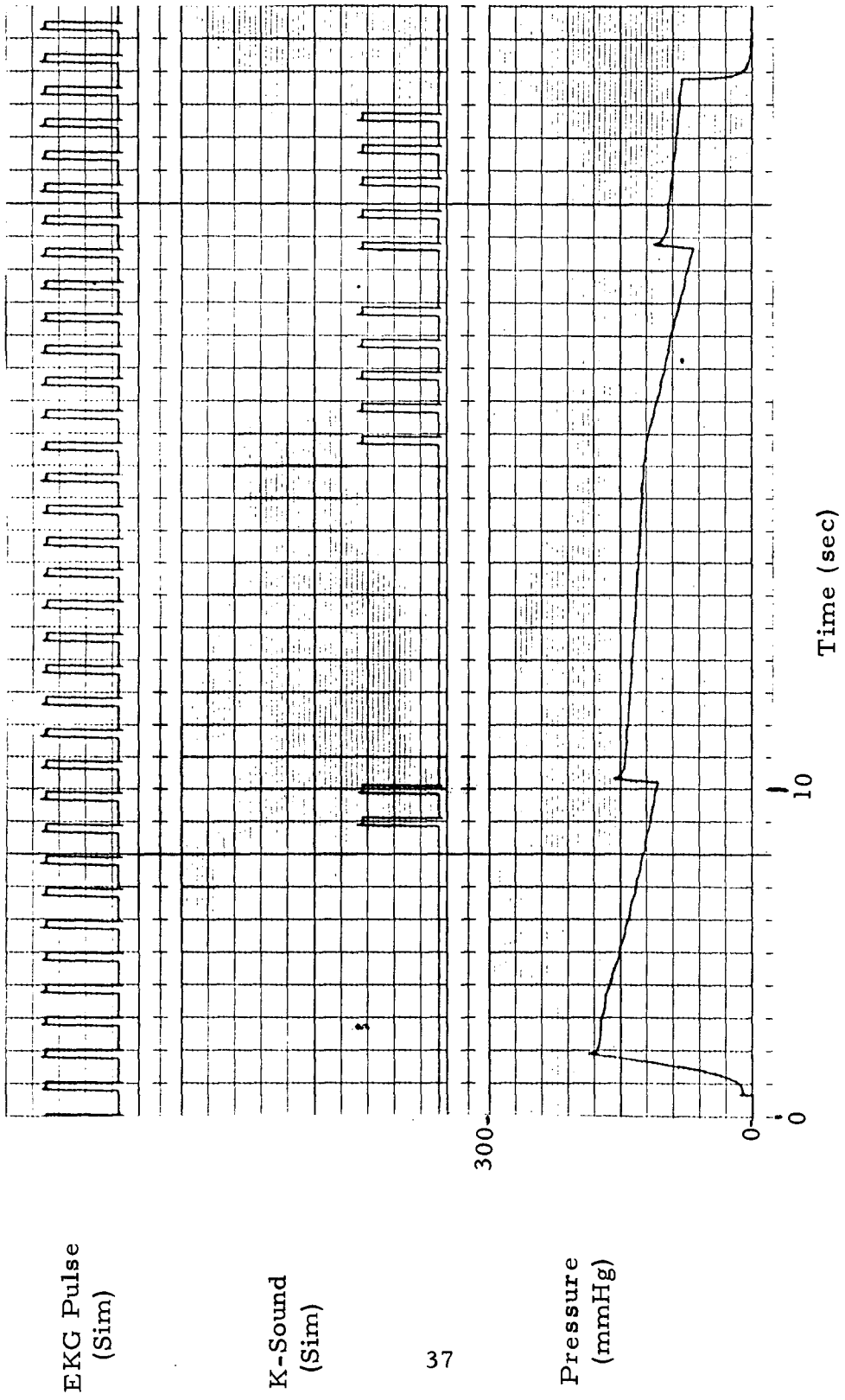

FIGURE 5.4-3

CYCLE RECORD

- 170 mmHg initial cuff pressure
- 30 second automatic cycle
- 20 mm/sec fast bleed rate
- 75 bpm heart rate after
- Repeat of cycle in approx. 1 1/2 hrs continuous operation

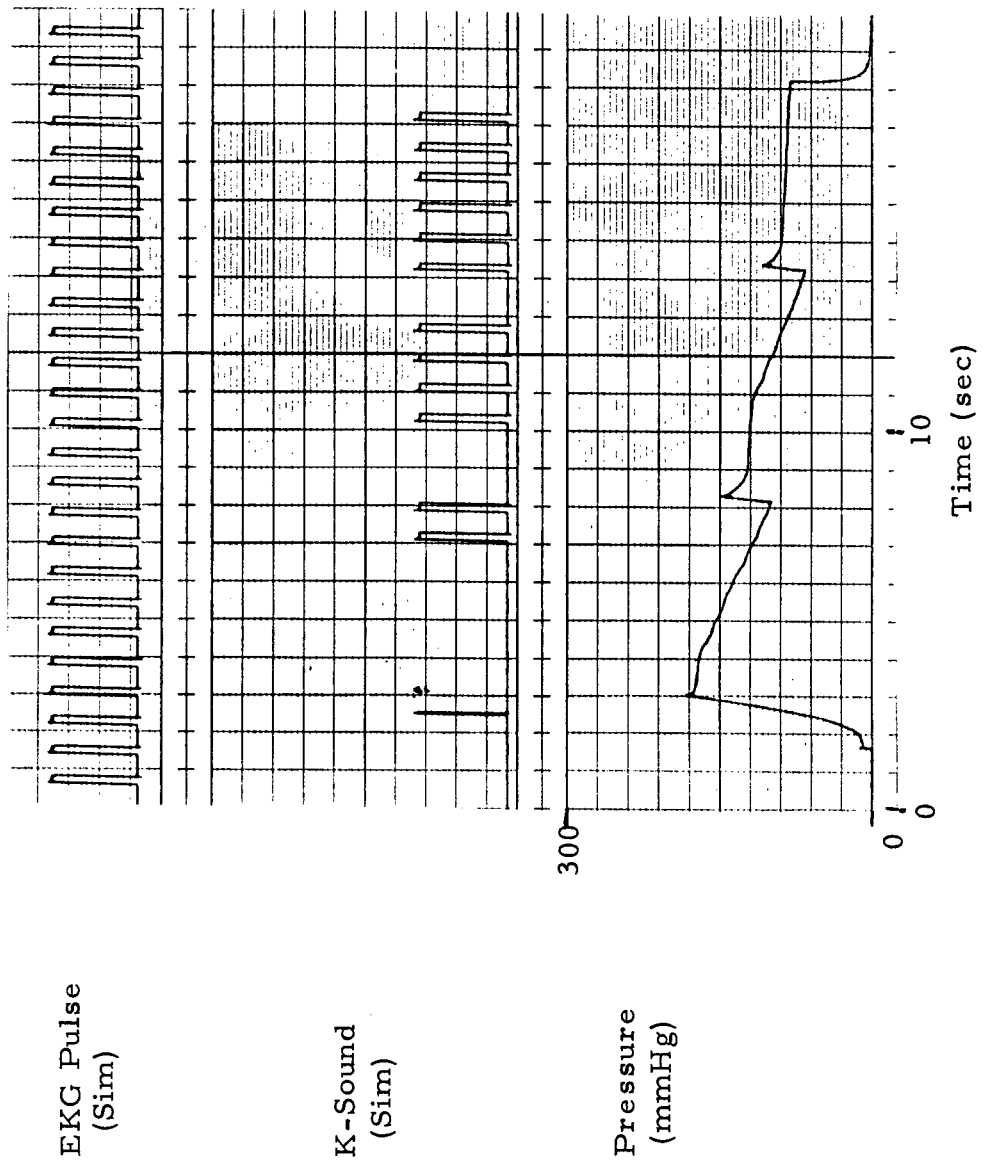

FIGURE 5. 4-4

CYCLE RECORD

- 260 mmHg initial cuff pressure
- 10 mm/sec fast bleed rate
- 60 second automatic cycle
- 75 bpm heart rate

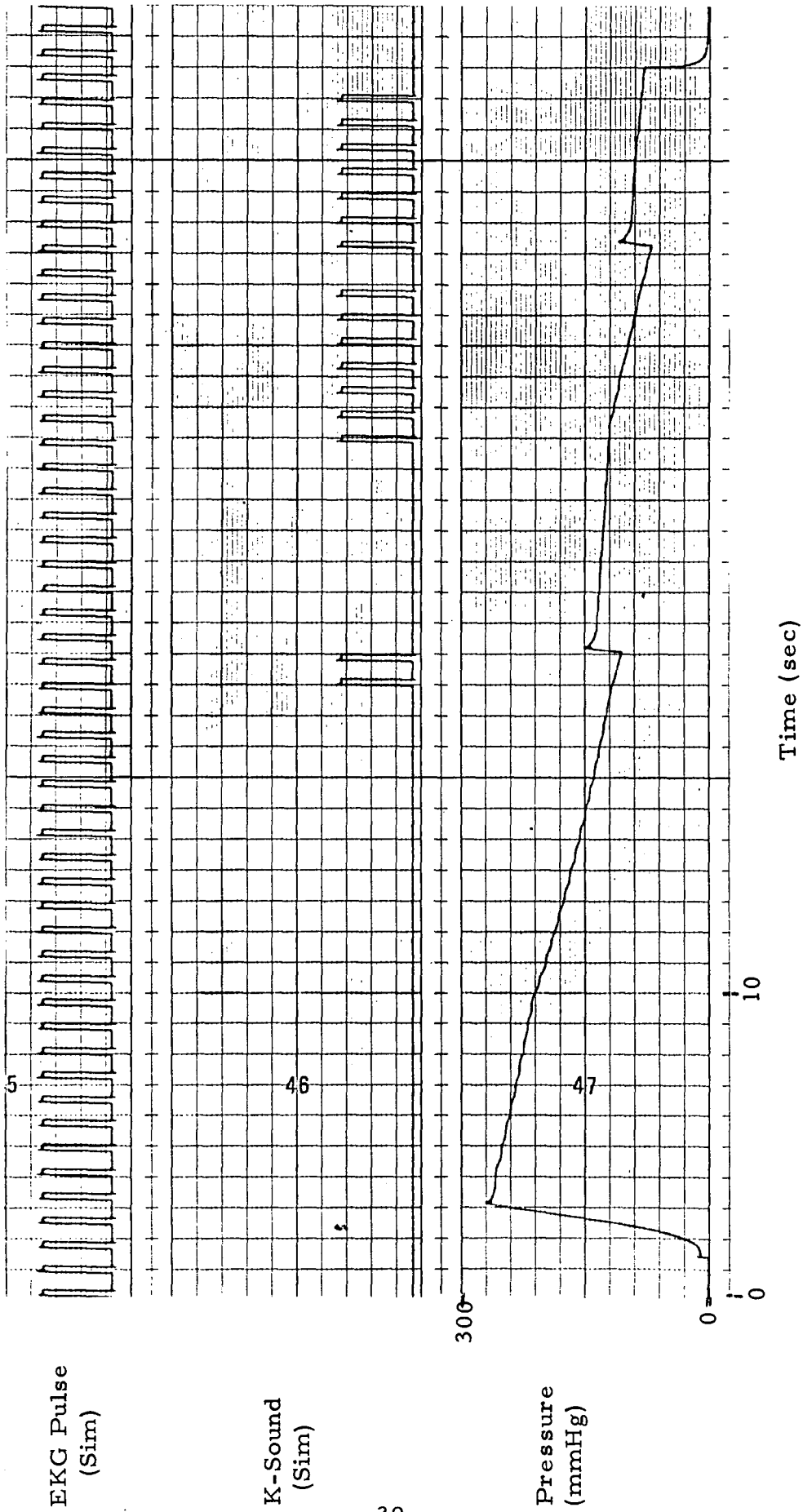

FIGURE 5.4-5

## 6.0 RECOMMENDATIONS

The purpose of the Pressure Ramp Programmer Engineering Model development was to provide a subsystem which, on receipt of externally generated control signals, will automatically program a specific cycle of inflation and deflation (and pressure levels), of an arterial cuff for blood pressure monitoring. This was accomplished. A recommended next step is to substitute the Engineering Model for the cuff pressure control portion of a blood pressure monitoring system and to operate this equipment combination, using live subjects, to verify the physiological aspects of the specific programmed cuff pressure cycle.

Some of the equipment, notably the bleed valve, was selected because of its ready availability and is capable of performing the required function. However, this valve was designed for occasional operation and not for the type of application and wear which it receives in this device. As a result, it was necessary to replace the valve item several times. Accordingly, it is recommended that a valve of an improved design be substituted for the present bleed valve. (Note: A required feature of the valve is that the rotating shaft where coupled to the motor does not translate).

7.0 APPENDIX

7.1 Engineering Model Requirements Specification

PRESSURE RAMP PROGRAMMER ENGINEERING MODEL

1.0 SCOPE

This specification defines the performance and design requirements for the Pressure Ramp Programmer Engineering Model and establishes requirements for its design, development and test. All contract end items of the subsystem shall conform to the requirements stated herein.

1.1 Purpose

The purpose of the Pressure Ramp Programmer Engineering Model shall be to provide conceptual verification of a subsystem applicable to manned space flight which will provide automatically programmed inflation and deflation of an arterial cuff for blood pressure monitoring.

1.2 Definitions

For the purposes of this document, the following definitions and abbreviations shall apply:

N/A

2.0 APPLICABLE DOCUMENTS

- 2.1 Supplemental Phase B-4 Additional Tasks, Statement of Work, Exhibit B, Contract NAS 9-10741 dated 30 April 1971, Task 3.0, Pressure Ramp Programmer.
- 2.2 Measuring Device, Blood Pressure, Automatic - Specification Number PD7400063 (last inc. change #8).
- 2.3 Interface Control Document, Experiment M092 Inflight Lower Body Negative Pressure to Experiment Support System, June 17, 1970 (including IRN PIRN A and MMC-G).
- 2.4 Critical Design Review Design Documentation for Automatic Blood Pressure Measuring Device, MMC Part Number PD7400063-020 dated August 1, 1970. Selected sheets as follows:

Dwg. 2480001 - Sheet 1, 2 of 2  
2480002 - Sheet 1 of 1  
PL2480002-020 - Sheet 2, 4, 5  
2480034 - Sheet 1 of 1  
2480040 - Sheet 1 of 1  
2480041 - Sheet 1 of 1  
2480042 - Sheet 1 of 1  
2480043 - Sheet 1, 2 of 2  
2480043-2 - Sheet 2, 3  
2480044 - Sheet 1 of 1  
2480044-1 - Logic Sheet  
2480045 - Sheet 1, 2 of 2  
2480046 - Sheet 1, 2 of 2  
2480046 - Sheet 1 thru 5 of 5  
2480047 - Sheet 1 of 1  
2480047-1 - Logic Sheet  
2480048 - Sheet 1, 2 of 2  
2480049 - Sheet 1, 2 of 2  
2480049-2 - Sheet 1 thru 4 of 4  
2480050 - Sheet 1 of 1  
2480051 - Sheet 1, 2 of 2  
2480052 - Sheet 1, 2 of 2  
2480052-2 - Sheet 1, 2, 3 of 3  
2480053 - Sheet 1 of 1  
2480054 - Sheet 1 of 1  
2480055 - Sheet 1, 2 of 2

Dwg. 248005-2 - Sheet 1, 2, 3 of 3  
2480056 - Sheet 1 of 1  
2480057 - Sheet 1, 2 of 2  
2480058 - Sheet 1, 2 of 2  
2480058-2 - Sheet 1, 2 of 2  
2480059 - Sheet 1 thru 4 of 4  
2480065 - Sheet 1 of 1  
2480066 - Sheet 1 of 1  
2480067 - Sheet 1 of 1  
2480068 - Sheet 1 of 1  
2480070 - Sheet 1 of 1

### 3.0 REQUIREMENTS

#### 3.1 Performance

##### 3.1.1 Functional Requirements

###### 3.1.1.1 Primary Performance Requirements

###### 3.1.1.1.1 Pressure Cycle

The engineering model shall provide the necessary equipments and controls to provide for automatic fill, bleed down and dump of an occluding cuff as shown by the representative cycle of Figure 3.1.1-1.

###### 3.1.1.1.1.1 Operating Modes

The engineering model shall be configured to provide three modes of operation:

- (a) Automatic cycling at 30 second intervals.
- (b) Automatic cycling at 60 second intervals.
- (c) Manual operation.

###### 3.1.1.1.1.2 Cuff Fill Pressure

For all modes of operation, discrete incremental maximum cuff pressure settings of 130, 150, 170, 200, 230, 260 and 300 mmHg pressure shall be manually selectable by the operator. For all modes, time to maximum fill shall be typically less than one second (two seconds maximum).

###### 3.1.1.1.1.3 Cuff Bleed Down

For all operating modes, the engineering model shall incorporate two fixed automatic bleed and reinflation rates as follows:

- (a) A rapid bleed rate resulting in a 10 or 20 mm Hg per second pressure drop (see Figure 3.1.1-1).
- (b) A slow bleed rate resulting in a 2 mm Hg per second pressure drop (see Figure 3.1.1-1).
- (c) Re-inflation to a 20 mm Hg pressure above the pressure level at which the first and last K sounds are detected shall be provided (see Figure 3.1.1-1). Re-inflation shall be accomplished in less than one second.

#### 3.1.1.1.1.4 Cuff Dump

In all operating modes, the engineering model shall automatically dump cuff pressure to a level of less than 3 mm Hg after sufficient time following the last K sound has lapsed to have allowed for one additional K sound to have occurred. (see Figure 3.1.1-1) If the pressure drops below 40 mm Hg, the cuff shall dump and the dump time shall not be greater than 1 second.

#### 3.1.1.1.1.5 Calibrating Pressures

For all operating modes, the engineering model shall automatically provide calibrating pressures to the pressure cuff. The maximal calibrating pressure shall correspond to the cuff pressure settings (3.1.1.1.1.2). The engineering model shall automatically hold this value for a nominal 5 seconds and then provide descending calibrating pressures in decrements of 40 mm Hg of cuff pressure down to a final cuff pressure of 40 mm Hg. Each calibrating pressure shall persist for a nominal 5 seconds.



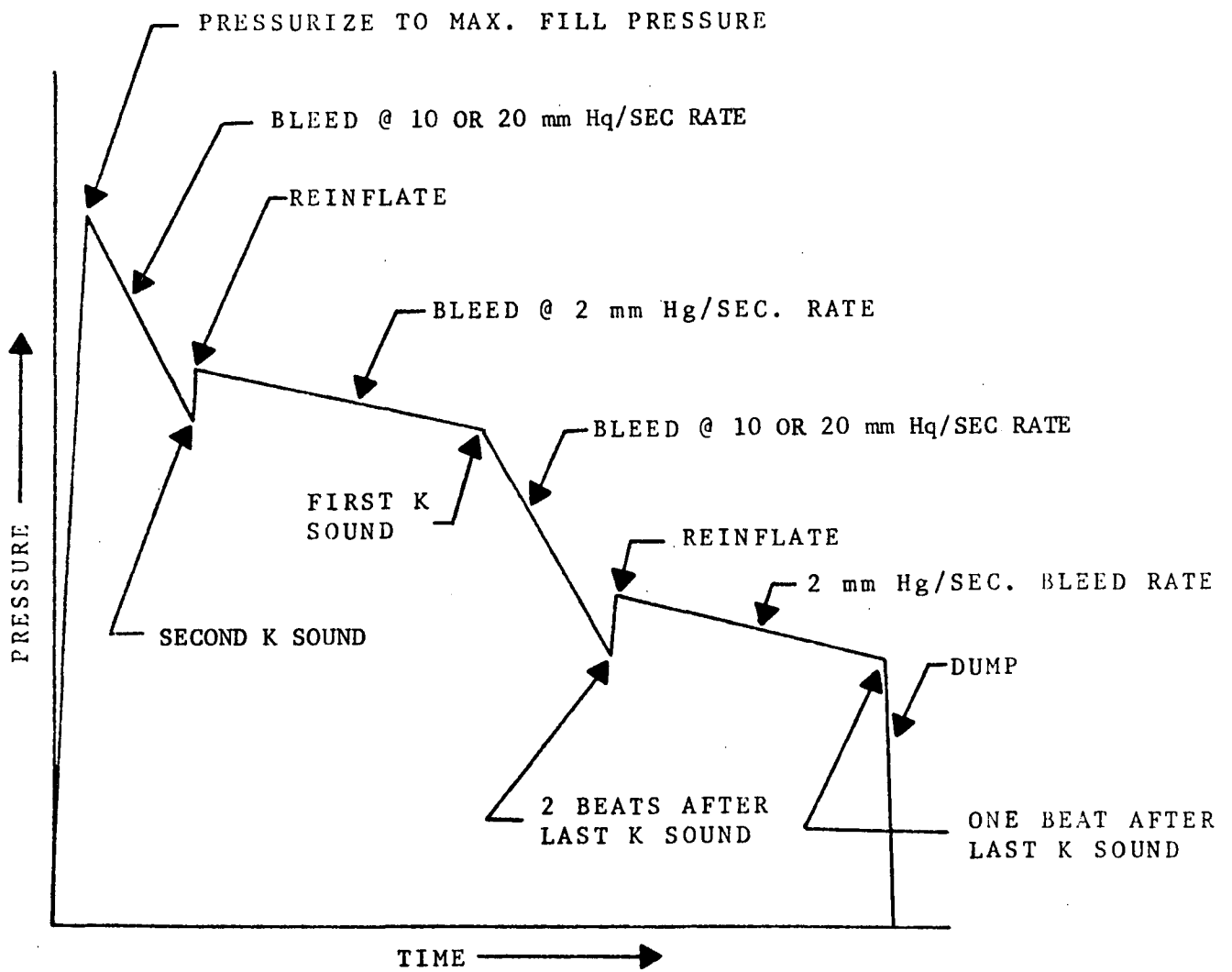

FIGURE 3.1.1-1. PRESSURIZATION CYCLE (TYP.)

#### 3.1.1.1.2 Equipment Requirements

The Pressure Ramp Programmer Engineering Model shall conform to the functional block diagram of Figure 3.1.1-2.

##### 3.1.1.1.2.1 Power Conditioning

The engineering model shall be designed to operate on 115 VAC, 60 Hz and/or 28 VDC  $\pm$  2 VDC unregulated power.

##### 3.1.1.1.2.2 Configuration

The engineering model shall be configured to provide a functional and attractive appearance consistent with the intended laboratory evaluation use. The model shall not be optimized for minimum size, weight and power.

##### 3.1.1.1.2.3 Operation

The engineering model shall be designed for a high degree of automatic operation. Manual control elements shall be easily accessible and positive acting. A manual override shall be provided which will terminate the cycle (for all operating modes) at any point during the cycle at the operator's discretion. Cuff pressure dump and stop of automatic cycling shall immediately follow the termination action.

##### 3.1.1.1.2.4 Displays

The engineering model shall provide a visual indication of key operational conditions.

#### 3.1.1.2 Secondary Performance Requirements

The Pressure Ramp Programmer Engineering Model shall conform to the block diagram of Figure 3.1.1-3.

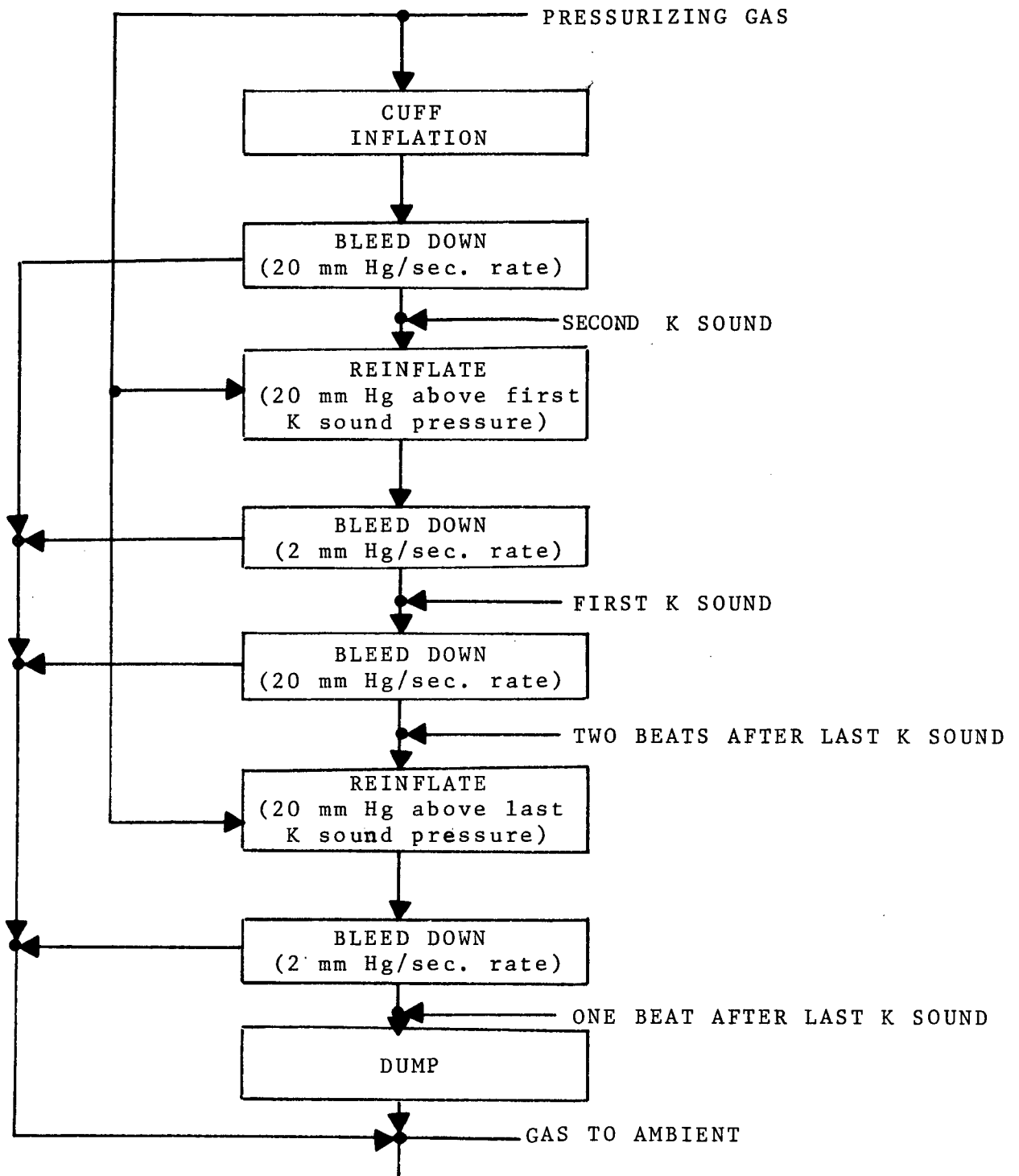

FIGURE 3.1.1-2. PRESSURE RAMP PROGRAMMER  
ENGINEERING MODEL FLOW CHART

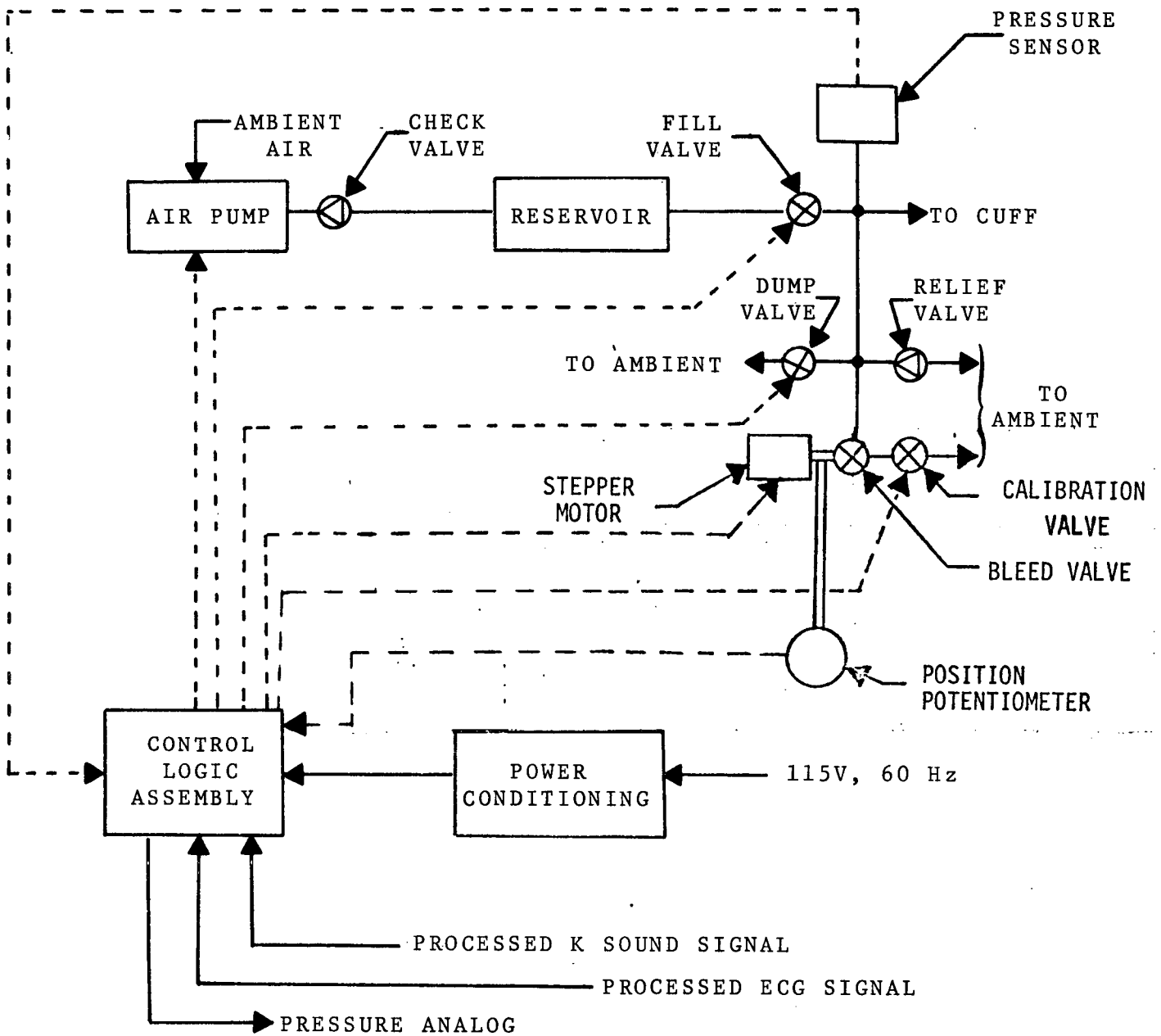

FIGURE 3.1.1-3. PRESSURE RAMP PROGRAMMER

ENGINEERING MODEL BLOCK DIAGRAM

#### 3.1.1.2.1 Size

The engineering model shall be configured to fit within an approximate envelope of 12 inches high, 12 inches wide and 18 inches long.

#### 3.1.1.2.2 Weight

The engineering model shall not be weight constrained.

#### 3.1.1.2.3 Component Description

##### 3.1.1.2.3.1 Air Pump Assembly

The function of the air pump assembly is to supply compressed ambient air to the reservoir. Specific design requirements are as follows:

- (a) Pump flow capacity shall be 1,000 ml/minute of air (at STP).
- (b) Maximum operating pressure shall be at least 15 psig.
- (c) A diaphragm type pump shall be used.
- (d) A direct connected, 1/20 hp, 115 volt, 60 Hz motor shall be used to operate the pump.
- (e) Envelope dimensions for the air pump assembly shall not exceed 4 x 5 x 8 inches.

##### 3.1.1.2.3.2 Reservoir

The function of the reservoir is to provide sufficient air for one complete pressurization of the cuff. Specific design requirements are as follows:

- (a) Reservoir volume shall be 1,000 ml minimum.
- (b) Maximum operating pressure shall be less than 20 psig.
- (c) The reservoir shall be constructed of non-corrosive materials.
- (d) Burst pressure shall be at least 10 times the maximum operating pressure.
- (e) Outline dimensions shall not exceed a nominal 4 inch diameter x 10 inches long.

### 3.1.1.2.3.3 Cuff Fill Valve

The cuff fill valve, on command, permits pressurized air to flow from the reservoir to the cuff. Specific design requirements are as follows:

- (a) The valve shall be sized to have a capacity of 500 ml air flow (STP) for one second from the reservoir.
- (b) The valve shall be a normally closed solenoid operated valve.
- (c) Maximum time to close shall be less than 15 ms; maximum time to open less than 10 ms.
- (d) The valve shall operate on 28 VDC.
- (e) Maximum power input shall be 14 watts.

### 3.1.1.2.3.4 Cuff Bleed Valve Assembly

The bleed valve assembly consists of a precision metering valve and stepper motor. Input pulses to the stepper motor control the valve setting and consequently the cuff bleed rate. Specific design requirements are as follows:

- (a) Valve flow capacity shall be compatible with a 0 to 20 mm Hg per second pressure drop bleed rate over the cuff fill pressure range of 130 to 300 mm Hg.
- (b) The valve shall be capable of being cycled from full open operating position to full closed (and the reverse) in two seconds.
- (c) The valve shall be provided with mechanical or electrical stops to prevent valve damage due to stepper motor overrun for both the full closed and full open positions.
- (d) Valve closing/opening torque requirements shall be less than 16 oz-in.

- (e) Stepper motor power requirements shall not exceed 12 watts at 5 VDC.
- (f) Outline dimensions shall not exceed a nominal 3 x 3 x 8 inches.

#### 3.1.1.2.3.5 Cuff Dump Valve

The function of the dump valve is to permit the cuff to rapidly exhaust to ambient. Specific requirements are as follows:

- (a) The valve shall be sized for a flow capacity of 500 ml (STP) of air, at 5.8 psig (300 mm Hg) initial conditions, to ambient in one second.
- (b) The valve shall be a normally open solenoid operated valve.
- (c) Maximum time to open shall be less than 10 ms.
- (d) The valve shall operate on 28 VDC.
- (e) Maximum power input shall be 14 watts.

#### 3.1.1.2.3.6 Reservoir Check Valve

The purpose of the reservoir check valve is to permit intermittent operation of the air pump. Specific requirements are as follows:

- (a) Valve opening pressure differential shall be 1/3 psi.
- (b) Minimum flow capacity shall be 1,000 ml air per minute.
- (c) The valve shall open/close automatically as the function of the applied pressure differential.

#### 3.1.1.2.3.7 Cuff Relief Valve

The function of the cuff relief valve is to prevent excessive cuff pressures resulting from equipment malfunction or other reasons. Specific design requirements are as follows:

- (a) Valve opening pressure differential shall be 6.75 psi (350 mm Hg).
- (b) Minimum flow capacity at the valve opening pressure shall exceed the reservoir/air pump output.
- (c) The valve shall be a mechanical type which opens/closes automatically as a function of the applied pressure differential.

#### 3.1.1.2.3.8 Pressure Sensor

The function of the pressure sensor is to provide cuff pressure feedback data to the control circuitry. Specific design requirements are as follows:

- (a) The pressure sensor range shall be linear from 0 to 6 psig with a total range of 0 to 7 psig.
- (b) Frequency response shall be flat to 100 Hz.
- (c) Excitation voltage shall be 6 VDC, power input less than one watt.
- (d) Performance shall not be degraded by exposure to pressure excursions to 15 psig.
- (e) Output voltage shall be approximately 0 to 1.25 volts.
- (f) Non-Linearity shall be less than  $\pm 1\%$  of full range output.
- (g) Hysteresis shall be less than 0.1% of full range output.
- (h) The sensor shall be operable into load impedances of 1K ohm or greater.
- (i) The sensor shall be insensitive to temperature changes over the range of 50 to 90°F.

#### 3.1.1.2.3.9 Control Logic Assembly

The control logic assembly shall provide the necessary control and timing signals as required for manual and automatic mode operation. Activation of the manual/automatic selector switch shall allow the



operator to select the cycle time desired, either manual, 30 seconds or 60 seconds. Specific requirements are as follows:

- (a) The control logic shall automatically fill the pressure cuff upon operator initiation of the START switch and at the end of a 30 or 60 second timed interval if repetitive operation is required.
- (b) When the pressure in the cuff, as sensed by the pressure transducer, reaches the operator selected upper limit, the control logic shall close the fill valve and open the bleed valve to fast bleed (10 or 20 mm Hg/second) and shall maintain the bleed rate constant at that rate by sensing the pressure change per unit time and varying the bleed valve setting so that the pressure change per unit time is constant.
- (c) Upon receiving a K sound signal, the control logic shall store the cuff pressure.
- (d) After the receipt of one additional K sound, the control logic shall open the fill valve and re-inflate the cuff to 20 mm Hg (10 mm Hg desired) above the original stored pressure.
- (e) The control logic shall then open the bleed valve to slow bleed (2 mm Hg/second) and maintain this slow bleed by pressure feedback (as for fast bleed).
- (f) Upon receiving a K sound indication, the control logic shall change the bleed rate to 10 or 20 mm Hg/second.
- (g) Upon detecting a lack of K sound signal, the control logic will store cuff pressure. The control logic will then count one additional pulse and close the bleed valve.
- (h) The control logic will open the fill valve until the cuff pressure is of 20 mm Hg (10 mm Hg desired) above the stored value. The fill valve is then de-energized.

- (i) The control logic will then set the bleed valve to slow bleed. When a lack of K sound signal is again received, the dump valve will be activated.
- (j) When the cuff pressure reaches zero, the control logic will be reset. It will be reactivated manually or automatically depending on the position of the mode selector switch.  
the mode selector switch.
- (k) An ABORT/RESET (cycle stop) switch shall be provided so that the operator may dump the cuff and reset the logic at any time during the cycle.

#### 3.1.1.2.3.10 Motor Drive Unit

The motor drive unit provides input drive pulses to the stepper motor when triggered by pulses from the control logic assembly. Specific requirements are as follows:

- (a) The motor drive unit shall be matched to the stepper motor.
- (b) Input power at 5 VDC shall not exceed 15 watts.
- (c) The drive unit shall supply a drive pulse to the stepper motor on receipt of a 5 volt pulse of 0.3 ms duration (typical).

#### 3.1.1.2.3.11 Power Conditioning Assembly

The power conditioning assembly shall operate from 115 VAC 60 Hz. It shall provide conditioned power to the control logic and electromechanical components as required. Specific design requirements are as follows:

- (a) +15 VDC +1% at 150 ma
  - (1) Line and load regulation shall be ±.01%.
  - (2) Ripple shall not exceed 1 mv.

- (3) The output shall be capable of withstanding a short circuit to ground indefinitely at 25°C.
- (4) The envelope of the +15 VDC power supply shall be less than 4.5" x 4.5" x 4.5" including mating connector.
- (5) The +15 VDC power supply shall be capable of operating from 0° to 60°C with no more than a +3% change in output.

(b) +5 VDC +1% at 1 amp

- (1) The regulation of the +5 VDC power supply shall be +1% line and load.
- (2) Ripple shall be less than 1 mv.
- (3) The +5 VDC power supply shall be capable of withstanding a short circuit to ground indefinitely at 25°C.
- (4) The +5 VDC power supply shall occupy an envelope no greater than 4.5" x 4.5" x 1.5" including mating connector.
- (5) The +5 VDC power supply shall be capable of operating from 0 to 60°C with no more than a +3% change in output voltage.

(c) + 5 VDC at 5.7 amps

- (1) The regulation of the +5 VDC stepper motor power supply shall be 1% line and load.
- (2) Ripple shall be less than 20 mv.
- (3) The +5 VDC stepper motor power supply shall be capable of withstanding a short circuit to ground indefinitely at 25°C.
- (4) The +5 VDC valve driver supply shall occupy an envelope no greater than 3.5" x 6.0" x 5.0".

#### 3.1.1.2.3.12 Structure Assembly

A structure assembly shall be provided for mounting and supporting the engineering model equipments. Specific design requirements shall be as follows:

- (a) The structure assembly with other equipments installed shall conform to the overall envelope dimensions of 3.1.1.2.1.
- (b) Specific equipments shall be located to minimize potential EMI problems and length of plumbing runs consistent with normal maintenance requirements.
- (c) The structure assembly shall be designed to withstand normal laboratory use.

#### 3.1.1.2.4 System Operation

The engineering model equipment operating sequence shall be as follows (reference Figures 3.1.1-1, 2 and 3):

##### 3.1.1.2.4.1 Start-up

- (a) Power ON switch actuated by operator.
- (b) 115 V, 60 Hz and 28 VDC power applied to electronics.
- (c) Power ON indicator light actuated.
- (d) Warm-up delay completed, if required by electronics.
- (e) Air pump actuated for 20 seconds (to assure reservoir at full pressure).
- (f) Maximum fill pressure selected by operator.

##### 3.1.1.2.4.2 Calibration Pressures (User Option)

- (g) DUMP valve actuated (closed).
- (h) Calibration switch actuated by operator.
- (i) FILL valve energized, opening reservoir to cuff.
- (j) FILL valve de-energized (closed) based on feedback data from the pressure sensor that selected calibration pressure has been achieved.

- (k) Actuate calibrate valve to automatically reduce cuff pressure in 40 mm Hg pressure steps, starting at the maximum fill pressure selected, and maintain each pressure level for  $\sim$ 5 seconds.
- (l) After last 40 mm Hg step open dump valve.

#### 3.1.1.2.4.3 Pressurization Cycle

- (m) Operating mode (manual, 30 second, 60 second cycle) selected by operator.
- (n) Cycle START switch actuated by operator.
- (o) FILL valve energized, opening reservoir to cuff (fill time - one second).
- (p) FILL valve de-energized (closed) based on feedback data from the pressure sensor that selected maximum fill pressure achieved.
- (q) Simultaneously with FILL valve closure, BLEED valve opening continuously driven to achieve a drop in cuff pressure of 20 (or 10) mm Hg per second based on feedback data from the pressure sensor.
- (r) Cuff pressure corresponding to receipt of first K sound signal "stored".
- (s) BLEED valve closes at receipt of second K sound signal.
- (t) FILL valve energized (opened) while BLEED valve closes.
- (u) FILL valve closed when cuff pressure increased to 20 mm Hg (10 mm Hg desired) above "stored" pressure for first K sound signal (see [q] above) as determined by pressure sensor data feedback.
- (v) Simultaneously with FILL valve closure, BLEED valve driven continuously reset to achieve a drop in cuff pressure of 2 mm Hg per second based on pressure sensor feedback data.
- (w) At receipt of first K sound signal, drive BLEED valve to provide a drop in cuff pressure of 20 mm Hg per second (or 10) based on feedback data from the pressure sensor.
- (x) Cuff pressure corresponding to receipt of last K sound signal "stored".

- (y) At end of period equivalent to receipt of two additional K sounds (e.g., 2 seconds at a heart rate of 60; one second at a heart rate of 120), close BLEED valve.
- (z) FILL valve energized (opened) while BLEED valve closes.
- (aa) FILL valve closed when cuff pressure increased to 20 mm Hg (10 mm Hg desired) above pressure "stored" for last K sound signal as determined by pressure sensor data feedback.
- (bb) Simultaneously with FILL valve closure, BLEED valve driven continuously to achieve a drop in cuff pressure of 2 mm Hg per second based on pressure sensor data feedback.
- (cc) At end of period equivalent to receipt of one additional K sound, DUMP valve de-energized (opened). NOTE: Open DUMP valve if cuff pressure drops below 40 mm Hg for any reason.
- (dd) Actuate air pump for five seconds.
- (ee) Deactivate air pump.
- (ff) For 30 and 60 second cycle operating modes, repeat 3.1.1.2.4.3 automatically every 30 or 60 seconds. For manual operating mode, operator actuation of START switch (see [m] above) required.
- (gg) If for any reason the 30 second cycle cannot be completed in 30 seconds, the equipment shall automatically operate in a 60 second repeat mode.

#### 3.1.1.2.4.4 Pressurization Cycle - Manual Override

- (hh) Operator actuates RESET/ABORT switch (at any time during the cycle).
- (ii) DUMP valve de-energized (opened).
- (jj) All valving/logic reset to cycle start condition.
- (kk) Manual or automatic cycling resumed by actuation of START switch by operator (see [m] above).

#### 3.1.1.2.4.5 Pressurization Cycle - Automatic Override

- (ll) Pressure sensor output corresponding to 350 mm Hg cuff pressure exceeded.

- (mm) DUMP valve automatically de-energized (opened).
- (nn) All valving/logic reset to cycle start conditions.
- (oo) Manual or automatic cycling resumed by actuation of START switch by operator (see [m] above). (Prior actuation of RESET switch required.)

### 3.1.2 Operability

#### 3.1.2.1 Reliability

Engineering model reliability shall be achieved by reliance on maintenance procedures rather than redundancy.

#### 3.1.2.2 Maintainability

The engineering model shall be designed to provide component accessibility, replaceability and serviceability consistent with the intended use.

#### 3.1.2.3 Useful Life

The engineering model shall be designed for a minimum useful laboratory life, with maintenance, of 12 months.

#### 3.1.2.4 Operating Environment

The engineering model shall be designed to operate under conditions normally encountered in engineering or physiological test laboratories.

#### 3.1.2.5 Human Engineering

Human Engineering factors shall be considered in the design and layout of the engineering model.

#### 3.1.2.6 Safety

##### 3.1.2.6.1 Operator/Subject Safety

The engineering model shall be designed to prevent hazardous conditions and inadvertent operation. Specifically,

- (a) Sharp edges, corners or equal shall be eliminated.
- (b) All electrical junction points shall be insulated or otherwise covered to prevent accidental contact.

- (c) A mechanical pressure operated relief valve shall be provided to prevent excessive cuff pressures in case of equipment malfunction.
- (d) An alternate overpressure relief means shall be provided based on pressure sensor output data.
- (e) Power interruption to the engineering model shall result in immediate dump of cuff pressure.
- (f) All components shall be grounded to the structure with provisions on the structure for connecting to an external ground provided.

#### 3.1.2.6.2 Equipment Safety

The engineering model shall incorporate fail-safe features. Specifically, fault isolation and over/under voltage protection shall be provided as required.

### 3.2 Interface Requirements

#### 3.2.1 SKYLAB Blood Pressure Monitor

The engineering model shall be designed to interface with the SKYLAB Blood Pressure Monitor to the extent specified herein.

##### 3.2.1.1 Electrical

###### 3.2.1.1.1 K Sound Signal

Filtered and pre-processed K sounds shall be transmitted to the engineering model as a 0-5 VDC pulse of approximately 1 ms duration. This pulse shall be capable of driving standard TTL logic. A fanout capability of two TTL standard loads shall be required.

###### 3.2.1.1.2 ECG Signal

One ms, duration, 0-5 VDC pulses coincident with each ECG QRS complex shall be provided to the engineering model. The input shall be compatible with standard TTL logic and shall have a fanout capability of two TTL standard loads.

###### 3.2.1.2 Mechanical

The engineering model shall interface with the SKYLAB Blood Pressure Monitor pressure cuff assembly via a quick disconnect type coupling.



### 3.2.2 Electrical Power

The engineering model shall be designed to operate on 115 V, 60 Hz power and/or 28 VDC.

### 3.2.3 Mechanical

The engineering model shall be self-supporting (structurally).

## 7.2 LIST OF DRAWINGS

	<u>GE Dwg No</u>
<u>ASSEMBLY</u>	
Pressure Ramp Programmer	ER47D224718
<u>MECHANICAL</u>	
Bleed Valve Assembly	ER47B224717
Bleed Valve Bracket	ER47B224712
Reservoir Support Bracket	ER47B224711
Manifold	ER47B224713
Adapter Plate Assembly	ER47B224714
Enclosure	ER47C224715
Cover	ER47C224716
Flex Coupling Modification	ER47A224777
Pot Support Bracket	ER47B224778
<u>ELECTRICAL</u>	
Power Distribution Block Diagram	ER47C224761
Power Distribution	ER47D224763
Analog Card 1	ER47C224764
Analog Card 2	ER47C224767
Relay Card	ER47C224762
Control Logic (AUGAT Board)	ER47D224770
and	ER47C224766
and	ER47C224768
and	ER47C224771
Analog Card 3	ER47C224769
△P Track and Hold	ER47C224773
Driver Card	ER47C224774
-----	
Pressure Ramp Programmer Simulator Circuit	ER47C224779

### 7.3 OPERATING INSTRUCTIONS

No special precautions are required when operating the Pressure Ramp Programmer Engineering Model. Cuff overpressurization is prevented automatically by actuation of either static or dynamic pressure relief elements. The pressurization cycle may also be terminated and cuff pressure dumped by manual actuation of either the power (OFF) or abort switches at any time during a pressurization cycle.

Programmer operation (in conjunction with a Blood Pressure Monitor) requires the following action by the operator:

#### STEP 1 - Interface Connections

- (a) Connect an input/output signal cable (not part of Pressure Ramp Programmer) from the Blood Pressure Monitor to the Input/Output connector J2 located on the side of the chassis.
- (b) Connect the power input cable (120 volts, 60 Hz, and 28 VDC @ 2 amps to the power connector (J1) located on the side of the chassis.
- (c) Connect the Blood Pressure Monitor arterial cuff to the Pressure Ramp Programmer via the quick disconnect fitting located on the housing cover near the reservoir.

#### STEP 2 - Start-up

- (a) Actuate the "POWER ON" switch. The "POWER ON" light will indicate programmer ready for operation.

#### STEP 3 - Calibration

- (a) Set Maximum Fill Pressure selector switch to desired fill pressure.
- (b) Actuate Calibration switch. This action lights the switch and initiates the automatic calibration sequence. At the end of the calibration sequence, the switch light will be automatically deactivated.
- (c) Calibration sequence performed at operator's option.

#### STEP 4 - Pressurization

- (a) Select operating mode (manual or 30 or 60 second automatic recycling).
- (b) Select maximum fill pressure via fill pressure selector switch if Step 3 omitted or different value desired.
- (c) Select cuff fast bleed rate by activating bleed rate switch.
- (d) Actuate "START" switch. At this point, the "START" switch is lighted and Pressure Ramp Programmer automatically proceeds through the pressurization cycle and stops at the end of the cycle if in the manual mode or repeats automatically if in the 30 or 60 second recycle mode.

At the termination of each individual pressurization cycle, the "START" switch light goes off and stays off until the pressurization cycle is re-initiated by actuating the "START" switch if in the manual mode or by the automatic action of the 30 and 60 second recycle mode.

#### STEP 5 - Emergency Cycle Termination

- (a) Actuate "RESET/ABORT" switch. This action immediately dumps the pressure in the cuff and resets programmer elements to cycle start conditions. Reactivation of the "START" switch is required to restart pressurization cycling, even when operating in the 30 or 60 second recycling mode.
- (b) Cycle termination due to a cuff overpressure condition (as detected by the pressure sensor) will occur automatically with results and restart requirements as above. Operation of the mechanical relief valve will not cause cycle termination.

#### STEP 6 - Shut-Down

- (a) Re-activate the "POWER ON" switch. This action removes all power from the programmer. If shut-down occurs during a pressurization cycle, either by intent or due to a power interrupt, cuff pressure is automatically dumped through the normally open dump valve.
- (b) Disconnect arterial cuff, power cable and input/output signal cable.

#### 7.4 CYCLE TIME ANALYSIS

The attached GE PIR 1R61-71-122 summarizes results of a cycle time analysis for the Pressure Ramp Programmer.



MISSILE AND SPACE DIVISION  
PHILADELPHIA

*CLASS. LTR.	OPERATION	PROGRAM	SEQUENCE NO.	REV. LTR.
U	1R61	71	122	
PIR NO.				
*USE "C" FOR CLASSIFIED AND "U" FOR UNCLASSIFIED				

**PROGRAM INFORMATION REQUEST/RELEASE**

FROM H. Ziller, Life Systems Room M4432, VFSC Ext. 6599	TO G. Fogal, Life Systems Room M4214, VFSC Ext. 5636
---	--

DATE SENT 7/20/71	DATE INFO. REQUIRED	PROJECT AND REQ. NO.	REFERENCE DIR. NO.
----------------------	---------------------	----------------------	--------------------

SUBJECT  
BLOOD PRESSURE CYCLE TIME

**INFORMATION REQUESTED/RELEASED**

Per your request, I have reviewed the effects of re-pump pressure on the blood pressure cycle time. As an approach to this problem, I set two arbitrary heart rates with what I believed to be realistic systolic and diastolic pressures for those rates. With these pressures and heart rates, I then plotted the cycle times under three re-pump pressures. These pressures were 20 mm Hg, 15 mm Hg, and 10 mm Hg.

GRAPH ONE Heart Rate 120 BPM  
Blood Pressure 160/80

GRAPH ONE is a typical example of a trained subject undergoing a mild stress such as a moderate exercise program. I purposely placed the initial pump-up pressure at 300 mm Hg as a worst case example. Assuming systolic pressure to 160, the time required to reach the first sound is 7 seconds  $\pm 0.5$  seconds. At two beats per second, the greatest error in determining a preliminary systole is one-half a second. This means at 20 mm Hg/second bleed down, we can be within 10 mm Hg of "true systole" on the first sound. The 20 mm Hg bleed down continues for two more beats per the S.O.W. This continued bleed down also adds to the total cycle time (one second at 120 BPM) and allows a larger drop in pressure from the true systolic pressure.

A. Little (5) C. Reinhardt, Jr. S. Gottlieb Dr. Hoffler (NASA-Houston)	PAGE NO.  1 OF 12	<input checked="" type="checkbox"/> RETENTION REQUIREMENTS	
		COPIES FOR	MASTERS FOR
66		<input type="checkbox"/> 1 MC.	<input type="checkbox"/> 3 MOS.
		<input type="checkbox"/> 3 MOS.	<input type="checkbox"/> 6 MOS.
		<input type="checkbox"/> 6 MOS.	<input type="checkbox"/> 12 MOS.
		<input type="checkbox"/> MOS.	<input type="checkbox"/> MOS.
		<input type="checkbox"/>	<input type="checkbox"/> DO NOT DESTROY

GRAPH ONE shows that the second pump-up pressure is extremely important to cycle time. When the secondary bleed rate begins, the time is fixed by the pressure increase. If the pressure is 20 mm Hg the time to first systolic sound is 10 seconds, at 15 mm Hg, 7.5 seconds, and at 10 mm Hg, 5 seconds. The dotted line on this graph shows that a cycle cannot be completed in 30 seconds with the secondary pump-up of 20 mm Hg. It can be completed using either of the shorter times, i.e., 10 or 15 mm Hg.

The search for the diastolic is a repeat of the systolic search and adds to the total cycle time in the same way.

In the conditions of GRAPH ONE, the first conclusion seems to be that reduction of the re-pump time to 10 or 15 mm Hg would solve the problem.

GRAPH TWO presents another problem which should now be discussed. In this graph, the heart rate is 60, the blood pressure 110/75. In this graph, the initial pump-up pressure of 160 mm Hg is a more realistic starting point than the 300 mm Hg which would be ridiculous at that pressure. If the initial pump-up was 160 mm Hg and the systolic pressure is 110 mm Hg, the delta of 50 mm Hg is reached in 2.5 seconds. Here the error of detection of the first or "true systole" is increased. The worst case detection would be to just miss the "true systolic beat". The next chance for detection is one second later or 20 mm Hg below the "true systole". If the bleed down rate of 20 mm Hg continues for two beats beyond the first as indicated by the S.O.W., the pressure has dropped BELOW the diastolic pressure before the second sound is heard. This would, of course, mean that no

HEART RATE 120  
BLOOD PRESSURE 160/80

GRADUAL ONE

●●● 20 mm Hg  
- - - 15 mm Hg  
— 10 mm Hg

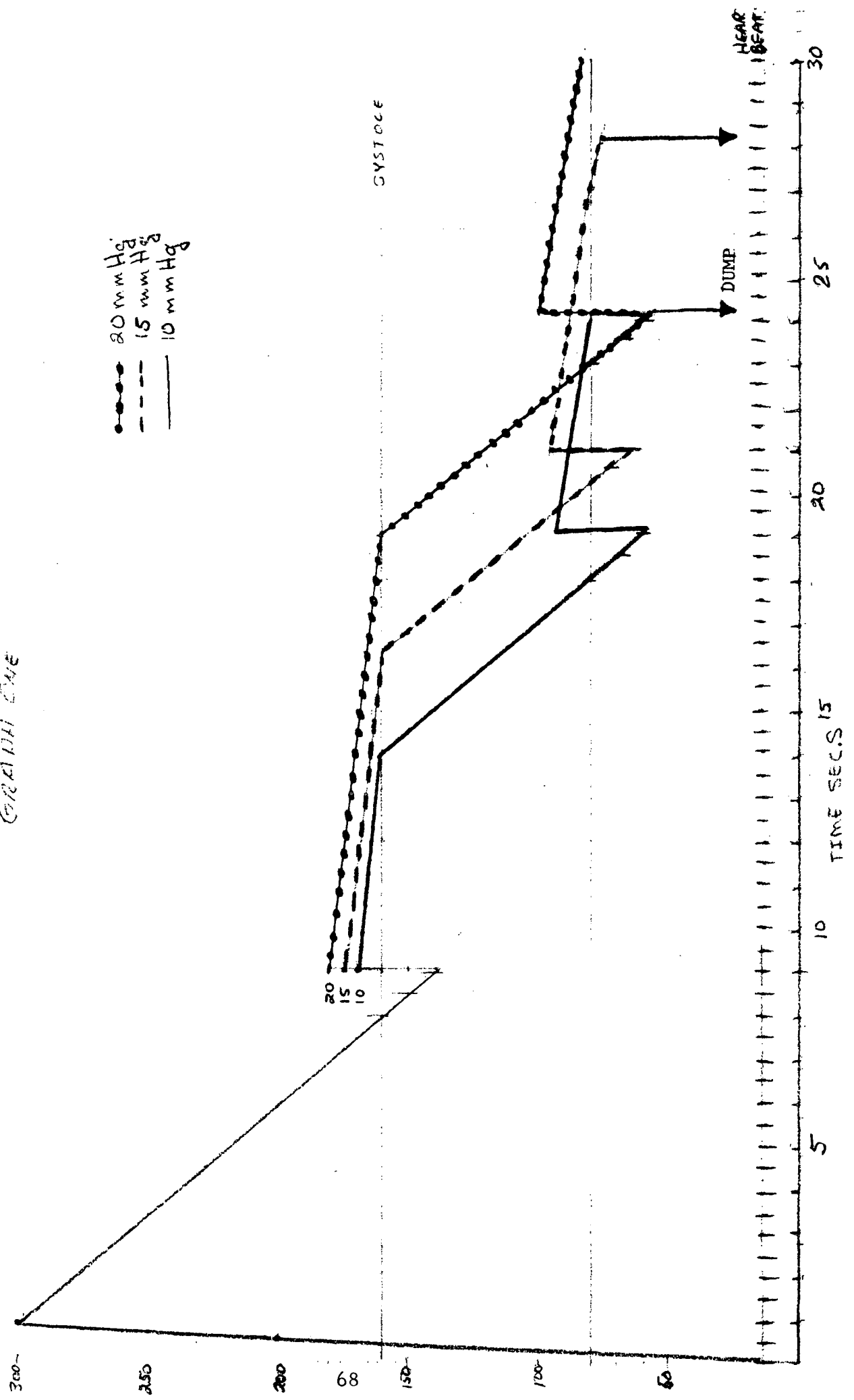



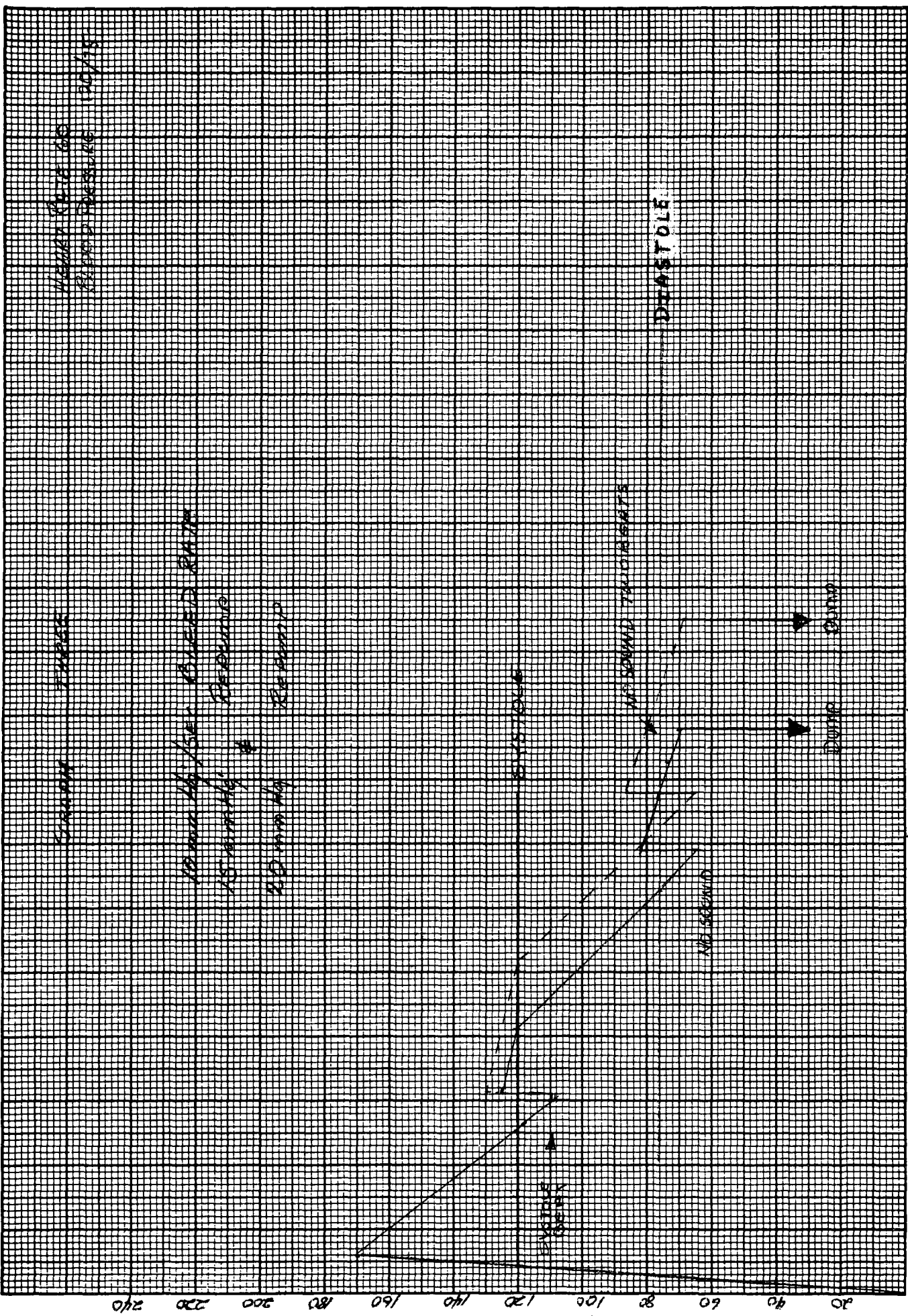

1 2 3 4 5 6 7 8 9 10 11 12 13 14 15 16 17 18 19 20 21 22 23 24 25 26 28 30 32 34 36 38 40

third sound would be heard. The 20 mm Hg/second bleed rate would continue until there was no pressure left and the cycle would be abortive. In this case, the delay for two additional beats becomes destructive to the entire cycle.

The other problem is that if we assume the worst case in coordination of the heart beat to the pressure, i.e., does a heart beat occur when the pressure is on the true systole, our greatest error is at 20 mm Hg. Yet if a 20 mm Hg re-pump is used, there is no way of completing the cycle in 30 seconds. If the 15 mm Hg re-pressure is used in the ultimate worst case, the second value for systole would be 5 mm Hg too low. The probability for the occurrence of the heart beat with a pressure are beyond my ability for calculation, but as attempts to define the situation more closely a review of mechanics may help clarify.

Assume that the cuff pressure is falling at 20 mm Hg/second and the heart is beating at some rate which is unknown. The best possible situation for our purposes is to have the two independent events arrive together at the "true systole" simultaneously. The worst situation occurs when the heart beat occurs just before the true systolic pressure is reached. In this case, the pressure decrease continues while the sensing system continues to wait for the next beat. The error is then compounded by the length of time necessary for the next beat to occur. If the next beat does not occur in a time period which will allow a 15 mm Hg re-pump to equal or exceed the "true" systolic pressure, a fallacious systolic pressure will result.

HEART RATE 60  
BLOOD PRESSURE 110/75

GRAPH TWO

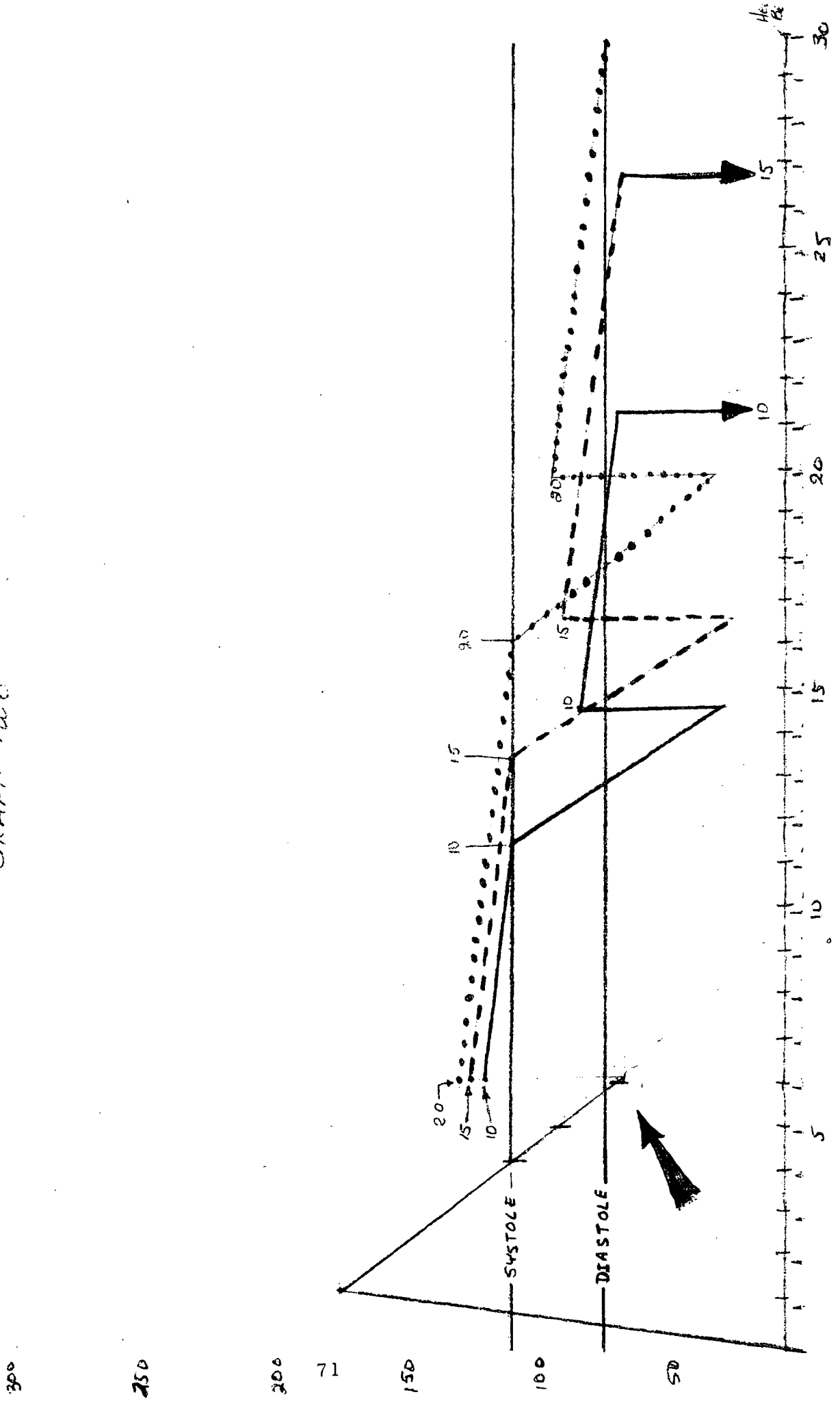

If Figure 1 is a representation of a pressure fall on which is super-imposed the heart beat, true systolic pressure lies between heart beats A and B. Heart beat A occurs above systolic pressure and heart beat B below it. But heart beat B is the signal which we receive. Now if the heart rate is sufficiently slow that a pressure drop of more than 15 mm Hg occurs, the recycle pump-up will be insufficient to reach the true systolic pressure. This situation can occur only when the heart rates are 60 BPM or below and then only when the first beat is spaced at a minimum distance away from the true systolic pressure

FIG. 1

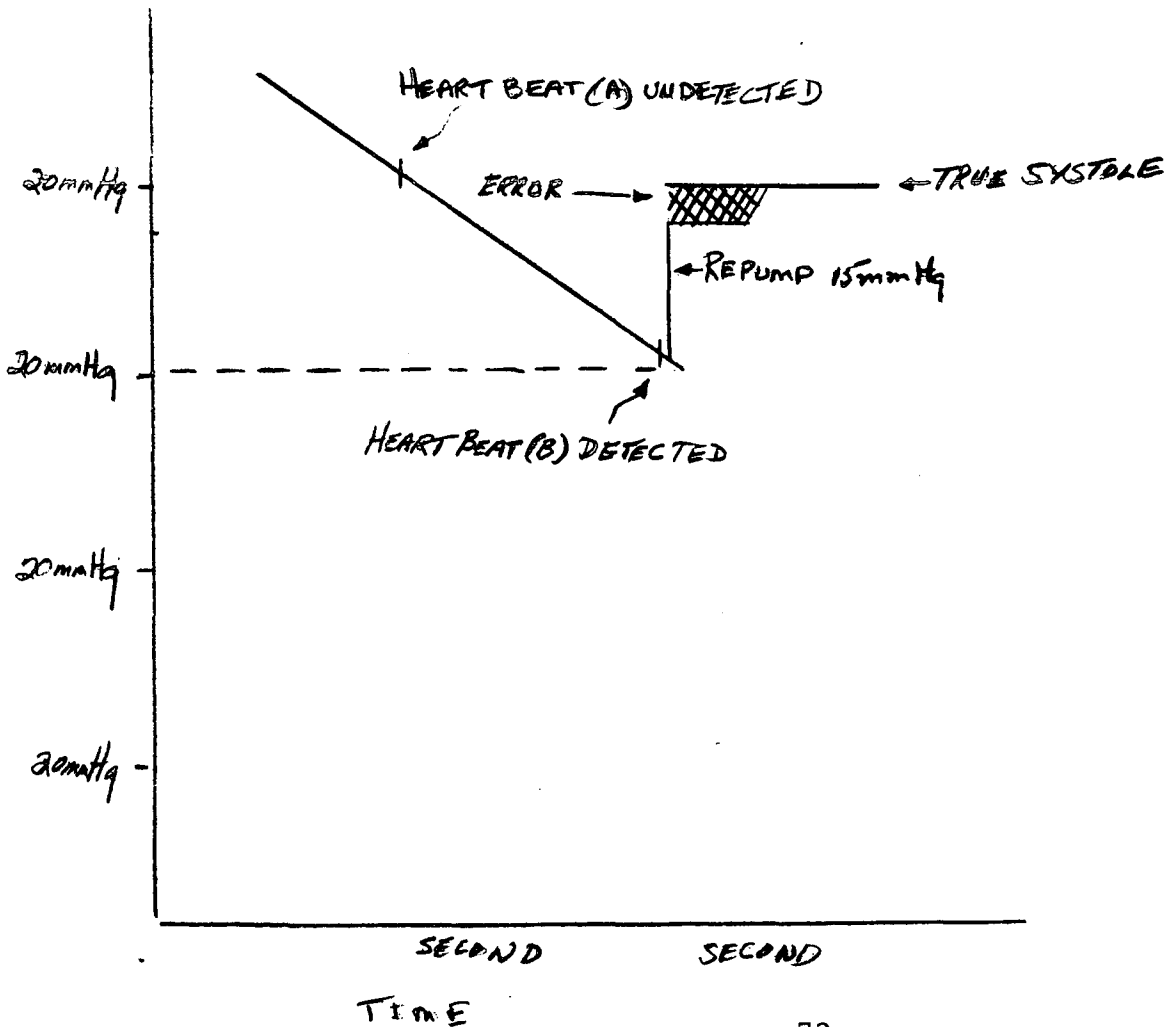

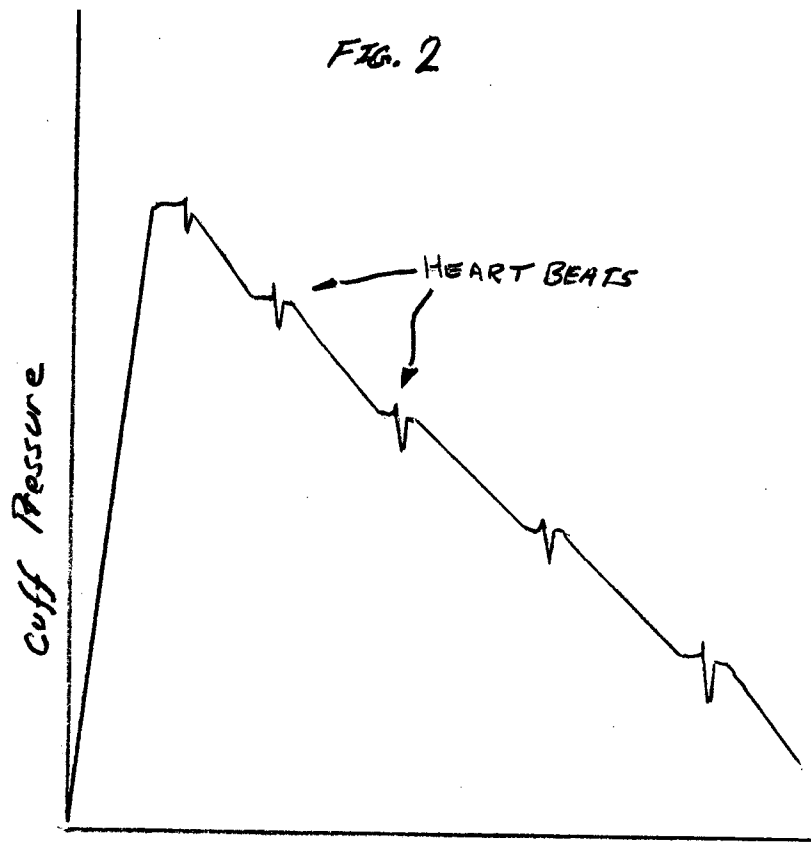

Another solution might be when heart rates are below 60, the bleed down rate is changed from 20 and 2 mm Hg/second to 10 and 2 mm Hg/second. This would require that the cycle time extend beyond 30 seconds, unless the initial pump-up pressure was very close to the true systolic pressure (110 mm Hg).

All these solutions are feasible with the last sounding most simple. However, I think it pertinent for a discussion as to what happens if we ignore the problem entirely. The question becomes how great is the error or errors produced by the device at the two bleed rates of 20 mm Hg/second and 2 mm Hg/second and a re-pump pressure of 15 mm Hg.

For discussion and arithmetic ease, the example will use a heart rate of 60 BPM. If one assumes some systolic pressure, the question becomes where does the heart beat have to occur to produce no error and what error will occur by different placement of the beat around

FIGURE 4

MAXIMUM ERROR

		mm Hg	
75%		0	
25%			
5%		0-1	
5%		1-2	
5%		2-3	-90%
5%		3-4	
5%		4-5	-95%

the "true" systolic pressure. Figure 3 shows some systolic pressure with a 20 mm Hg/second bleed rate and a 15 mm Hg re-pump at a heart rate of 60 BPM.

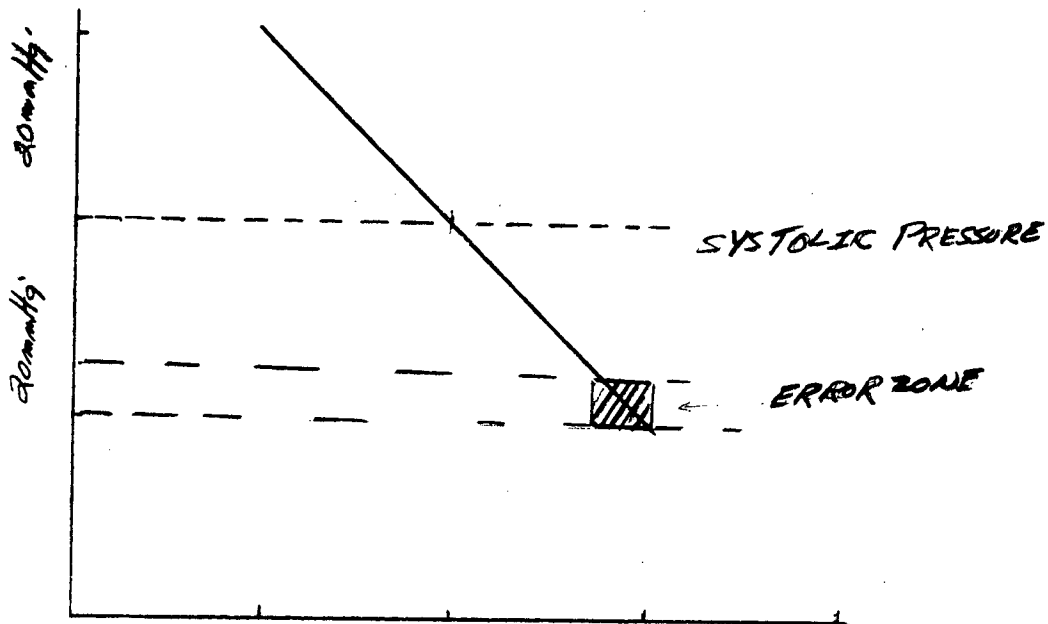

FIG. 3

Since a 15 mm Hg re-pump can account for a sound occurring in the first 3/4 of the second past "true" systole the last 1/4 is the only time at which error can occur. The error can be further broken down. (See Figure 4) There is no error 75% of the time, i.e., no error other than that which the device normally has. The remainder of the error can be further sub-divided into 5% increments shown in Figure 4.

By using Figure 4, one can see that 90% of the time the machine has an additional error not exceeding 3 mm Hg. It should be noted that this error is always below the "true" value for systole. The maximum error is 5 mm Hg.

If the same heart rate is considered, but the timing of the beat to the pressure cycle moved up so that the true systolic is moved closer to the detected beat, the 15 mm Hg re-pump is sufficient and the error eliminated. In summary, the explanation is this: the first detectable sound must come .75 seconds after the passing of true systolic pressure or an error in the resulting systolic pressure will occur. This error increases as the heart rate decreases.

GRAPH TWO presents another interesting problem mentioned earlier, the waiting for 2 additional beats beyond the first "sensed" systolic sound. If this third sound occurs below the diastolic level, it will obviously never be sensed. It seems that a better solution would be to sense only one sound after the first.

These two problems, i.e., the failure to get true systolic pressure with a 15 mm Hg re-pump and the time delay for the occurrence of the third sound, must be resolved for the unit to operate successfully. In my opinion, the first one is the one of major importance and unless some bright mathematician can give us the probability of failure, I suggest we continue to build the unit and test how often a false systole results. Other solutions might be to have a re-pump of 20 mm Hg above the first sensed sound at heart rates 60 and below or have the initial bleed down rate reduced when heart rates are at this level. It might also be possible to gate the emptying of the cuff with the E.C.G. In this system, the cuff would dump 20 mm Hg with each beat and then hold one beat when the microphone over the brachial artery sensed sound. This would assure that the cuff emptying was synchronized with the heart rate. (See Figure 2)



It is interesting to note that a heart rate of 72 BPM, the maximum error which can occur is -1.7 mm Hg and this error only occurs 5% of the time. The analysis of error leads, in my opinion, to two conclusions. The prototype unit being built now will be tested with normal or at least higher heart rates than 60 BPM; therefore, the error should be noted and known to occur, and accepted as inherent in the device. Any unit, i.e., other prototypes or any flight hardware must be fitted with a 10 mm Hg/second optional bleed rate and a 20 mm re-pump pressure for heart rates which are less than 60 BPM. This system should suffice down to a rate as low as 30 BPM. At this rate, the maximum delay before sound would be 20 mm Hg and the 20 mm Hg re-pump can recover this amount. Graph 4 is an example of the time periods for a 10 mm Hg/second fast rate, 2 mm Hg/second slow rate and a 20 mm Hg re-pump.

Your comments, criticism and questions are solicited.

## 7.5 LIST OF COMPONENT DATA SHEETS

Component data sheets available are as follows:

1. Brooks NRS Needle Control Valves  
Design Specifications and Installation and Operating Instructions
2. Brooks Sintered Metal Filters
3. Philips PD 20 Stepper Motor
4. Skinner Two-Way Solenoid Valves
5. Setra-Systems Model 230 Pressure Sensor
6. Circle Seal Pressure Relief Valve
7. Nupro Check Valve
8. Bourns Model 3500 Ten Turn Pot
9. ± 15 VDC Power Supply AC/DC Model CD15D. 37
10. +5 VDC Power Supply AC/DC OEM5N5. 7
11. +5 VDC Power Supply Semiconductor Circuits 1. 5. 1000
12. D/A Converter - Varadyne DAC HB-8B
13. Track and Hold - Hycomp MC800