

NASA CONTRACTOR REPORT

NASA CR-2036



NASA CR

0061324

TECH LIBRARY KAFB, NM

LOAN COPY: RETURN
AFWL (DOUL)
KIRTLAND AFB, N. M.

THE RELATION BETWEEN TIME OF PRESENTATION AND THE SLEEP DISTURBING EFFECTS OF NOCTURNALLY OCCURRING JET AIRCRAFT FLYOVERS

by T. E. LeVere, Raymond T. Bartus, and F. D. Hart

Prepared by

NORTH CAROLINA STATE UNIVERSITY

Raleigh, N.C. 27607

for Langley Research Center

NATIONAL AERONAUTICS AND SPACE ADMINISTRATION • WASHINGTON, D. C. • MAY 1972



0061324

1. Report No. NASA CR-2036	2. Government Accession No.	3. Recipient's Catalog No.	
4. Title and Subtitle The Relation Between Time of Presentation and the Sleep Disturbing Effects of Nocturnally Occurring Jet Aircraft Flyovers		5. Report Date May 1972	6. Performing Organization Code
		8. Performing Organization Report No.	
7. Author(s) T. E. LeVere Raymond T. Bartus F. D. Hart		10. Work Unit No.	
9. Performing Organization Name and Address North Carolina State University Raleigh, NC 27607		11. Contract or Grant No. NGL 34-002-095	
		13. Type of Report and Period Covered Contractor Report	
12. Sponsoring Agency Name and Address National Aeronautics and Space Administration Washington, DC 20546		14. Sponsoring Agency Code	
		15. Supplementary Notes	
16. Abstract The present research describes the sleep disturbing effects of jet aircraft flyover noise as it occurs at different times during the night. The results indicate that individuals respond statistically more, in terms of greater cortical desynchronization, during the first and last thirds of the night. During the middle third, while there is still a significant amount of cortical desynchronization in response to the jet aircraft noise, this is always less than that which occurs earlier or later in the night. The implications of this data are that it might be possible to reduce the disruptive effects of at least certain extrinsic sonic stimulation by appropriate scheduling.			
17. Key Words (Suggested by Author(s)) Noise Aircraft noise Sleep interference		18. Distribution Statement unclassified - unlimited	
19. Security Classif. (of this report) unclassified	20. Security Classif. (of this page) unclassified	21. No. of Pages 24	22. Price* \$3.00

INTRODUCTION

There can be little doubt that the auditory stimulation associated with even moderate levels of noise can have a wide range of disrupting effects upon an individual's physiological and psychological well-being (1, 2, 4, 13). Of the various noises and specific effects that are associated with sonic stimulation, transportation noise and its potential interference with an individual's normal sleep perhaps defines the most critical problem. This conclusion stems from the facts that: (A.) transportation noise, particularly jet aircraft noise, exhibits an alarming annual increase (2), (B.) sonic stimulation is one of the most effective extrinsic means of disrupting sleep, and (C.) partial and total sleep disruption can, in the extreme cases, precipitate epileptic seizures and bizarre hallucinations (3, 12). Further, and perhaps most importantly, the physiological and psychological states associated with even moderate amounts of sleep disruption can carry over and influence waking performance (5). With regard to these considerations, it would appear clear that meaningful control and abatement programs based on an adequate understanding of the effects of sonic stimulation should be initiated.

Considering the specific sleep disturbing effects of subsonic aircraft noise, there are two approaches which appear to offer some promise. The first involves engineering-design research directed at the elimination of noise. The progress of this approach has been chronicled in two NASA Langley sponsored symposiums (SP-189, 1968; SP-220, 1970) which reached the general conclusion that it is possible to obtain a 10 to 15 PHdB

reduction in aircraft noise over current levels by appropriate engine design. However, it was not altogether clear whether further reductions in noise would be economically feasible if at all possible within the limits of present technology. Thus while the problem of noise pollution can be profitably approached through engineering technology, this avenue, by itself, is not sufficient for the complete solution to the problem.

A second approach to the problem of noise pollution assumes that some amount of noise is, at least for the present, an accompaniment of contemporary society. Accepting this assumption, the corrective procedure becomes one of timing or scheduling activities to bring their associated noise levels within the limits commensurate with an individual's physiological and psychological well-being. Considering the problem of the sleep disturbing effects of jet aircraft sounds in this light, it is immediately apparent that any sort of noise control by this method would be hampered by a gross lack of laboratory data. In particular, little is known about the specific effects of this sort of auditory stimulation beyond the rather subjective assertion that jet aircraft noise can be quite annoying and can awaken sleeping individuals. Consequently before meaningful actions directed at minimizing the disruptive effects of jet aircraft noise can be initiated it would appear necessary to specify in some quantitative manner the actual effects that these stimuli might have on an individual's sleep. Toward this end, the research reported here attempted to determine whether similar jet aircraft sounds presented at different times during the night were all equally effective in influencing the individual's sleep pattern. To accomplish this, the frequency pattern of the recorded electroencephalograph (EEG) was used as the dependent measure of an individual's sleep and the

effectiveness of jet aircraft flyovers was evaluated in terms of the relative changes in patterning of the electrical activity of the brain.

METHOD

Subjects

The subjects for this experiment were six male adults between the ages of 24 and 40 years. All subjects were matched relative to their normal sleeping environments and none suffered from any disabilities which might interfere with their sleep. Furthermore, none of the subjects had been under a doctor's care or had taken any prescription medicine for at least six months prior to their participation in the experimental procedure. Each of the six subjects slept in our laboratory bedroom for 14 consecutive nights but, with this exception, were instructed not to otherwise change their normal daily routine.

Apparatus

The apparatus/hardware consisted of three major systems: 1) the laboratory bedroom and equipment to produce the jet aircraft sounds, 2) the EEG recording equipment, and 3) the EEG analysis system. The general floor plan and dimensions of the mock-up laboratory bedroom and toilet facilities are illustrated in Figure 1. Essentially the room was slightly larger than the average bedroom and measured approximately 20 ft. by 16 ft. not including the bath facilities and the equipment-control room. The general arrangement of furniture within the bedroom is shown in Figure 2. The composition and general appearance of this furniture was designed to minimize the laboratory atmosphere of the subject's

sleeping environment so that, with the exception of the speakers and some small behavioral test equipment, the room assumed the outward appearance of a small hotel room.

The sound stimuli were presented to the sleeping subjects by a standard Sony AM stereo tape recorder and two speakers located in adjacent corners of the wall opposite the subject's bed. A spectral analysis of the jet aircraft noise, as played back through this equipment and recorded from the approximate location of the subject's head during sleep, is presented in Figure 3.

The subject's scalp EEG was monopolarly recorded with a standard 9 mm Grass silver cup electrode attached to the P3 location (International 10-20 system) and referenced to the unilateral ear. A similar Grass electrode was attached to the subject's neck and used as a ground. The electrodes themselves were connected to a Grass model 79 Polygraph and from this to an Ampex SP700 FM tape recorder. Recording at the slowest possible speed, the full night's data (six hours of sleep) could be obtained on a single reel of 1/2 mil recording tape. A block diagram of this system is illustrated in Figure 4.

The restriction of our physiological recording to a single channel of EEG activity requires some elaboration. Firstly, it was deemed desirable to minimize the discomfort associated with the experimental procedure to insure that each subject adapted to our situation as rapidly as possible. Secondly, our analytical procedures were based solely on determining the changes in the frequency characteristics of the subject's sleeping EEG pattern as these might be related to the presentation of the jet aircraft stimuli. More specifically, the primary thrust of the

research was to determine whether or not the scalp recorded EEG showed any consistent characteristic increase in frequency (desynchronization) or arousal pattern in response to the jet aircraft flyovers. As such, it was felt that little would be gained by burdening the subject with the sort of array of electrodes which has been suggested for other sleep analysis schemes (11). Additional reasons for the restriction of the analytical procedures to a frequency analysis concern the statistical treatment of the data and are discussed below.

The hardware used to analyze the subject's EEG is illustrated in Figure 5. Basically, the system was composed of an Ampex SP700 FM tape recorder to reproduce the previously recorded analog EEG signal. This analog signal was sequentially passed through a 1.5 Hz high-pass filter and a 30.0 Hz low-pass filter to the analog-to-digital converter or a Digital Equipment Corporation PDP-12A computer. The digitized signal was then analyzed in accordance with a zero-crossing frequency analysis program (see below) and the results typed out in hard copy on a standard Model 33 ASR Teletype.

Procedure

Seven of the 14 nights which each subject spent in our laboratory bedroom were, with the exclusion of the first 3 nights, selected as "stimulus nights." The selection was random for each subject with the restrictions that the fourth night had to be a stimulus night and no more than three nights in succession could be stimulus nights. During these stimulus nights the subjects were exposed to the acoustic stimuli through the stereophonic speakers located within the bedroom. Each of

the recorded jet flyovers was played back to reach a loudness of approximately 80 dB(A) and have a duration of approximately 20 seconds. The actual presentation of the jet aircraft flyovers on these stimulus nights was in accord with a predetermined restricted random schedule based upon a total of 6 hours starting 15 minutes after the subject had retired. The 6 hours of sleep were divided into 3 2-hr periods each of which was further subdivided into 8 15-min blocks. The occurrence of a jet aircraft flyover at the beginning of any particular 15-min block was then randomly determined under the constraint that 3 flyovers must occur within each 2-hr period and that there could be no more than 2 successive 15-min blocks which started with a jet aircraft flyover. Thus, the schedule presented a total of 9 jet aircraft flyovers evenly, and randomly, distributed over each stimulus night.

The analysis of the subject's sleeping EEG was accomplished by the PDP-12A computer programmed for a zero-crossing frequency analysis following the procedures previously described in the NASA Symposium chaired by Procter and Adey (7) and more specifically by LeVere (9). Basically, the analysis converts the analog EEG signal to digital values at the rate of 200 points per second and determines individual half-wave frequencies on the basis of the elapsed time between successive crossings of zero-potential. In other words, if 250 msec elapse between the digitized record going from a negative value through a series of positive values and back to a negative value this would constitute a half-wave frequency of 2 Hz. The current version of the zero-crossing analysis further reduced the EEG data by summing the occurrence of similar frequencies during successive

40-sec analysis epochs according to the classical EEG band widths of Delta (0-3 Hz), Theta (4-7 Hz), Alpha (8-12 Hz) and Beta (12-30 Hz). Each of the 40-sec analysis epochs was necessarily separated by a 20-sec interepoch interval to allow for computer I/O time period.

The characterization of the subject's sleeping EEG was based on the level of cortical activation or frequency desynchronization that was observed during each 40-sec analysis epoch. Specifically, the level of cortical activation, or arousal as suggested by some authors (7), was determined by the amount of time consumed by each of the various frequency categories within each analysis epoch period. Table 1 presents the actual criteria used in the present analysis to determine which of 5 levels, 0 through 4, of cortical activation or desynchronization was present during each analysis epoch. The numerical values assigned to the desynchronization are inversely related to the amount of slow-wave or hypersynchronized activity computed by the zero-crossing program. For example, if 50% or more of the 40-sec analysis epoch was consumed by a hypersynchronous slow-wave Delta activity, the epoch was considered to be at a level 4 or the lowest level of cortical arousal used in our analytical procedure.

It should be noted that these levels of cortical desynchronization were intentionally designed to correspond quite closely to the EEG frequency criteria normally attributed to different stages of sleep (11). The current analysis should not, however, be interpreted as indicating stages of sleep since this determination depends upon a number of variables in

addition to electroencephalographic activity. Further, and more importantly, the statistical analysis of an individual's responsiveness to nocturnal acoustical stimuli with regard to changes in sleep stages would be somewhat tenuous, if at all appropriate, because of the difficulty of relating sleep stages to some measurement scale which would meet the assumptions required for statistical treatment (10). The present use of the more simple notion of cortical desynchronization as an indication of behavioral arousal adequately serves the purposes of the present research and does not violate the assumptions necessary for statistical treatment.

RESULTS

Considering the effectiveness with which the jet aircraft sounds influence a subject's sleeping EEG pattern at different times during the night, Figure 7 presents the mean change in cortical desynchronization that occurred in response to the nocturnal stimulation during the first 2 hours of sleep, the second 2 hours of sleep and the final 2 hours of sleep. This data was computed for each third of the night's sleep by determining the level of desynchronization for each subject for each of 6 40-sec analysis epochs starting with the analysis epoch during which a flyover occurred. These values were then subtracted from the epoch immediately preceding the flyover to obtain the change in cortical desynchronization that occurred in response to the jet aircraft noise. The figure presents this data as averaged across all subjects and all stimulus nights of the experimental procedure for each of the 3 2-hr periods of a night's sleep. The positive numbers of the ordinate of Figure 7 represent increasing amounts of cortical desynchronization

while the negative values represent increasing amounts of hypersynchronization. As controls, similar 7-min periods were randomly selected from within control nights when no jet aircraft flyovers were presented. This random selection was essentially similar to the manner in which the occurrences of jet aircraft flyovers were determined for stimulus nights inasmuch as the schedule evenly distributed the groups of 7 epochs across the control night and varied from subject to subject. This then not only made the control data comparable to the random selection stimulus nights, but also, since the random schedule varied from subject to subject, precluded the possibility that the control data might represent a biased sample from the nights when the subject's sleep was not disturbed.

Inspection of the figure and statistical analysis (Wilcoxon tests) indicate that the occurrence of the jet aircraft flyovers was effective ($p < .05$) during each third of the individual's sleep and this effect, in terms of cortical desynchronization or arousal, tended to outlast the stimulus by a considerable amount. However, the figure also suggests that in the early and late thirds of an individual's night sleep, the jet aircraft flyovers were somewhat more effective than during the middle 2-hr period. The actuality of this interaction is illustrated by the bar graph shown in Figure 8. This figure shows the relative change in sleep precipitated by the jet aircraft flyovers during the early, middle and late 2-hr periods and shows that while the change in cortical desynchronization is approximately equal for the early and late 2-hr periods it is significantly less during the middle 2-hr period (indicated probabilities derived from the Wilcoxon test). That is, during the early 2-hr

and the late 2 hr of an individual's total night's sleep, the occurrence of the recorded jet aircraft flyover sound caused a change in the individual's sleep pattern of approximately one full level of cortical desynchronization as defined in Table 1. However, during the middle portion of a night's sleep, the same acoustical stimulus was, while still greater than the control epochs, significantly less. Finally, it must be pointed out that during the middle 2-hr period, the fifth post-stimulus EEG analysis epoch was not significantly different from the control epoch just preceding the occurrence of the jet flyover. In contradistinction, during the early and late 2-hr periods the level of desynchronization of the fifth post-stimulus epoch was still significantly different ($p < .05$, Wilcoxon test) than the level of desynchronization computed during the epoch just preceding the flyover. Thus, this analysis would appear to indicate that the relative arousal effect of jet aircraft flyovers, as computed by cortical desynchronization, is significantly greater in both magnitude and duration during the early and late portion of an individual's sleep as compared to the middle portion.

DISCUSSION

The consistent and significant changes in the EEG frequency pattern during sleep observed in the present data and other previously cited research indicate that there is little question that individuals are responsive to nocturnal auditory stimulation. Further, the present results indicate that this responsiveness is not in any way limited to overt behavioral arousal since none of the subjects were able to accurately

recall the number of jet aircraft flyovers that occurred during a night if, indeed, they were able to recall the occurrence of even a single flyover. And finally, it must be pointed out that the observed EEG arousal was not restricted to the physical presence of the jet aircraft noise but outlasted the auditory stimulus by a considerable degree.

While these results are of interest in and of themselves, it is somewhat more important to note that the same physical stimuli presented during the initial 2 hr of sleep and during the terminal 2 hr of sleep were relatively more effective in producing cortical arousal than these same stimuli presented during the middle 2 hr of a night's sleep. This result is, at first glance, somewhat surprising in light of data which can be interpreted as indicating that subjects should be less responsive during early and late portions of a night's sleep because they tend to be in deeper stages of sleep during the early portion of the evening and spend more time in REM sleep during the early morning hours (12). However, two variations of the present research suggest that this sort of deduction may not be completely justified.

Firstly, the researches suggesting less responsiveness during early and late sleep were obtained by restricting the presentation of the extrinsic stimuli to specific types of sleep, i.e. stage 4 and/or REM, as these predominantly occur during the early and late portions of the night. The present data, on the other hand, did not so restrict stimulus presentations to particular types of sleep but simply asked more directly whether, on the average, the individual was more responsive during one two-hour period of the night than during some other two-hour period. As such, the present results do not address the question of

responsiveness during any particular type of sleep which may or may not dominate certain portions of sleep, but rather are concerned, as pointed out in the introduction, with whether or not there is a temporal parameter associated with the effectiveness of nocturnal auditory stimulation. The fact that up to 30% of the early portion of an individual's sleep may be devoted to the deeper stages of sleep is thus not necessarily at odds with the present result since the auditory stimuli were not, in fact, necessarily presented during these deeper stages of sleep. It may be more prudent, then, when considering the overall average effectiveness of the auditory stimulation to simply note that during the early portions of the night the individuals were attempting to go to sleep and during the later portions they were waking up--not what types or stages of sleep dominate these times. When considering the effectiveness of sonic stimuli in this light, the increased effectiveness of the sonic stimulation during the early and late portions of the night may be quite plausible.

A second point, which may be more germane to the issue, is that those researches which suggest that stimuli are less effective during deeper stages of sleep and during REM sleep are based upon the amount of stimulation required to produce subjective behavioral awakening. In contradistinction, the present procedures were based upon relative changes in a subject's neural activation in response to the auditory stimulation. That is, while there can be little question that to awaken a subject in a deeper stage of sleep a more intense stimulus is required, this does not mean that the relative amount of change in

cortical arousal during the deeper stage of sleep is any different than the relative change in cortical arousal during a lighter stage of sleep. The present procedures, with their dependence upon change in EEG frequency pattern and not behavioral awakening, may thus provide a more sensitive measure of the influence of auditory stimulation on an individual's sleep because of their independence of the prevailing state of sleep. More descriptively, simply because the auditory stimulus does not produce behavioral awakening does not in any manner mean that the stimulus was ineffectual.

The implications of these results are quite obvious. That is, if one wishes to minimize the disruptive character of nocturnal jet aircraft noises then these noises should be scheduled during the middle portion of the night. However, this implication must be viewed with some caution since not only were a small number of subjects used in the present research but also their ages were restricted to between 24 and 40 years, i.e. middle age, when individuals are becoming somewhat poorer sleepers (6). Further, notwithstanding the attempts made to minimize the laboratory setting associated with our procedure, it must be remembered that the studies were, in fact, conducted in a laboratory which could conceivably flavor the character of the results. However, with regard to these points, it should be emphasized that each subject was used as his own control so that the reported results reflect relative changes across treatment conditions. Thus, the results should be unaffected by age and laboratory setting since these are constant across both control nights and stimulus nights. At any rate, the indication that the disturbing effect of

aircraft noise in the present situation, may be reduced by scheduling procedures would seem important enough to warrant further investigation.

CONCLUSIONS

The presently reported research indicates that the auditory stimulation of jet aircraft flyovers at the relatively moderate intensity of 80 dB(A): (1) produces significant and physiological arousal patterns in sleeping subjects but not necessarily behavioral awakening, (2) the arousal outlasts the actual presence of the auditory stimulation, and (3) the degree of arousal is greater during the first and last thirds of the night. The latter finding suggests that the maximum effects of noise may be controlled through appropriate scheduling of high noise activities. At the very least, the results indicate that further research and specification of the temporal aspects of noise pollution might prove very worthwhile in lieu of complete abatement.

REFERENCES

- 1.) Burns, W. Noise and Man. J. B. Lippincott, Philadelphia, 1968, 336p.
- 2.) Dickerson, D. O., Hart, F. D., Gibson, J. D., and Jarvis, C. E. Transportation Noise Pollution. Control and Abatement. NASA Langley Research Center, Hampton, 190p.
- 3.) Johnson, L. C. Physiological and psychological changes following total sleep deprivation. In: Kales (Ed.). Sleep Physiology and Pathology, J. B. Lippincott, Philadelphia, 1969.
- 4.) Kryter, K. D. The Effects of Noise on Man. Academic Press, New York, 1970, 633p.
- 5.) LeVere, T.E., Bartus, R.T., and Hart, F.D. Electroencephalographic and behavioral effects of nocturnally occurring jet aircraft sounds. *J. Aerosp. Med.*, vol. 43, no. 4, 1972, pp. 384-389.
- 6.) Lukas, J. S., Dobbs, M. E., and Kryter, K. D. Disturbance of human sleep by subsonic jet aircraft noise and simulated sonic booms. NASA CR-1780, 1971.
- 7.) Magoun, H. W. The Waking Brain. Charles C. Thomas, Springfield, Illinois, 1963, 188p.
- 8.) Proctor, L. D., and Adey, W. R. (Eds.) Symposium on the Analysis of Central Nervous System and Cardiovascular Data Using Computer Methods. NASA SP-72, Clearinghouse for Federal Scientific and Technical Information, Springfield, 1965.
- 9.) Proctor, L. D., McCrum, W. R., LeVere, T. E., Lee, R. M., and van den Ende, H. The Analysis of Gemini VII EEG Data by Three Different Computer Oriented Methods. NASA CR-90235, 1967.
- 10.) Rechtschaffen, A., Hauri, P., and Zeitlin, M. Auditory Awakening Thresholds in REM and NREM Sleep Stages. Perceptual and Motor Skills, 1966, 22, 927-942.
- 11.) Rechtschaffen, A., and Kales, A. (Eds.) A Manual of Standardized Terminology, Techniques, and Scoring System for Sleep Stages of Human Subjects. Public Health Service, U. S. Government Printing Office, Washington, 1968.
- 12.) Webb, W. B. Partial and differential sleep deprivation. In: Kales (Ed.) Sleep Physiology and Pathology, J. B. Lippincott, Philadelphia, 1969.
- 13.) Welch, B. L., and Welch, A. S. (Eds.) Physiological Effects of Noise, Plenum Press, New York, 1970.

Activity within Epoch

		Delta	Theta	Alpha	Beta
Level of cortical desynchronization	0	-----Default Option-----			
	1	NA	30%	30%	NA
	2	NA	30%	30%	NA
	3	50%-20%	NA	NA	NA
	4	50%	NA	NA	NA

TABLE I

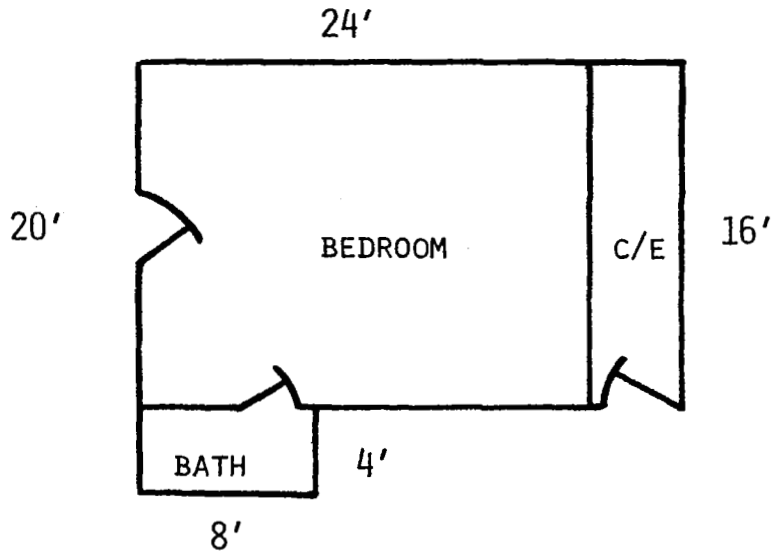

TOP PROFILE

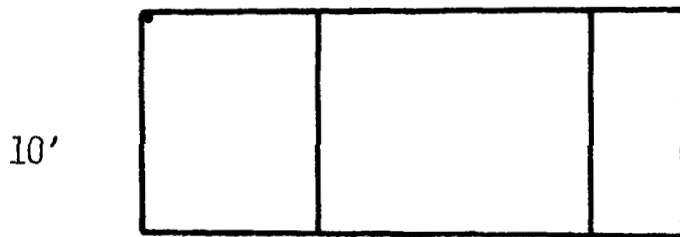

SIDE PROFILE

Floorplan and general dimensions of the sleeping area used in the present experimental procedures. The recording equipment was housed adjacent to the bedroom in the space marked "C/E."

FIG. 1

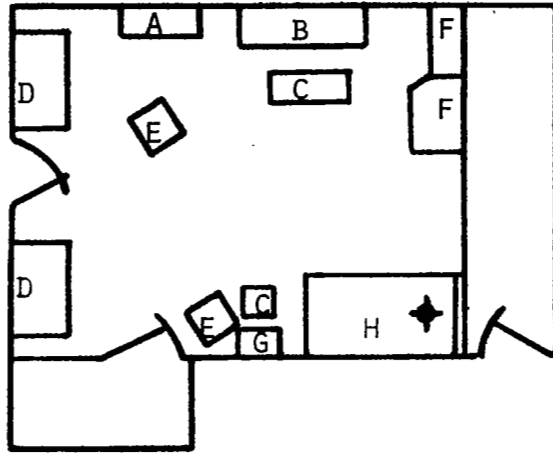

WHERE: A=DRESSER; B=COUCH; C=TABLE; D=SPEAKER;
 E=CHAIR; F=TEST EQUIP.; G=POST; H=BED
 ◆=POINT OF SOUND MEASUREMENT

General arrangement of furniture within the sleeping area.

FIG. 2

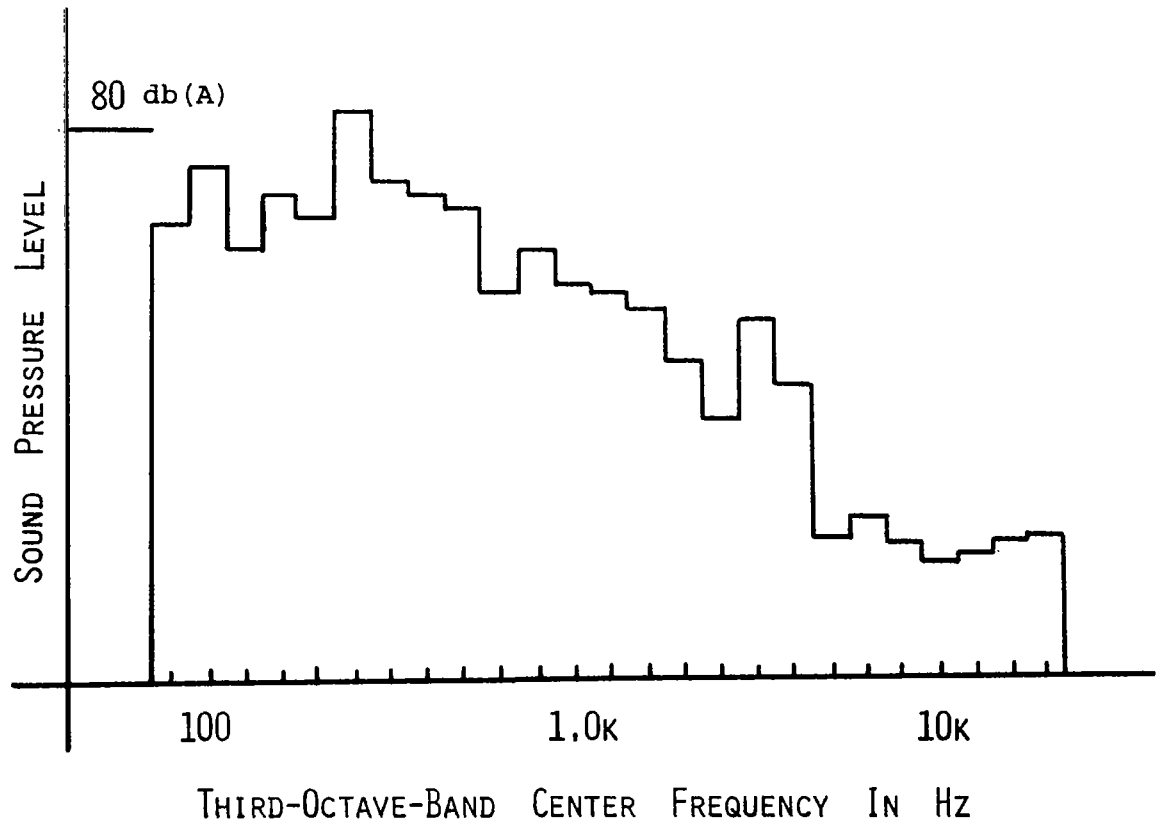

Spectral analysis in 1/3 octave bands of jet aircraft sound as recorded from approximate location of subject's head during sleep. The analysis was accomplished with a 1/2 in. condenser microphone and analyzed by a GR real time analyzer set for a 2 sec. integration time. The spectrum corresponds to the sound when the aircraft (Boeing 707) was, in effect, overhead. A Doppler effect which caused a slight shift in the lower frequencies could be noted but is not represented in the spectrum presented in this figure.

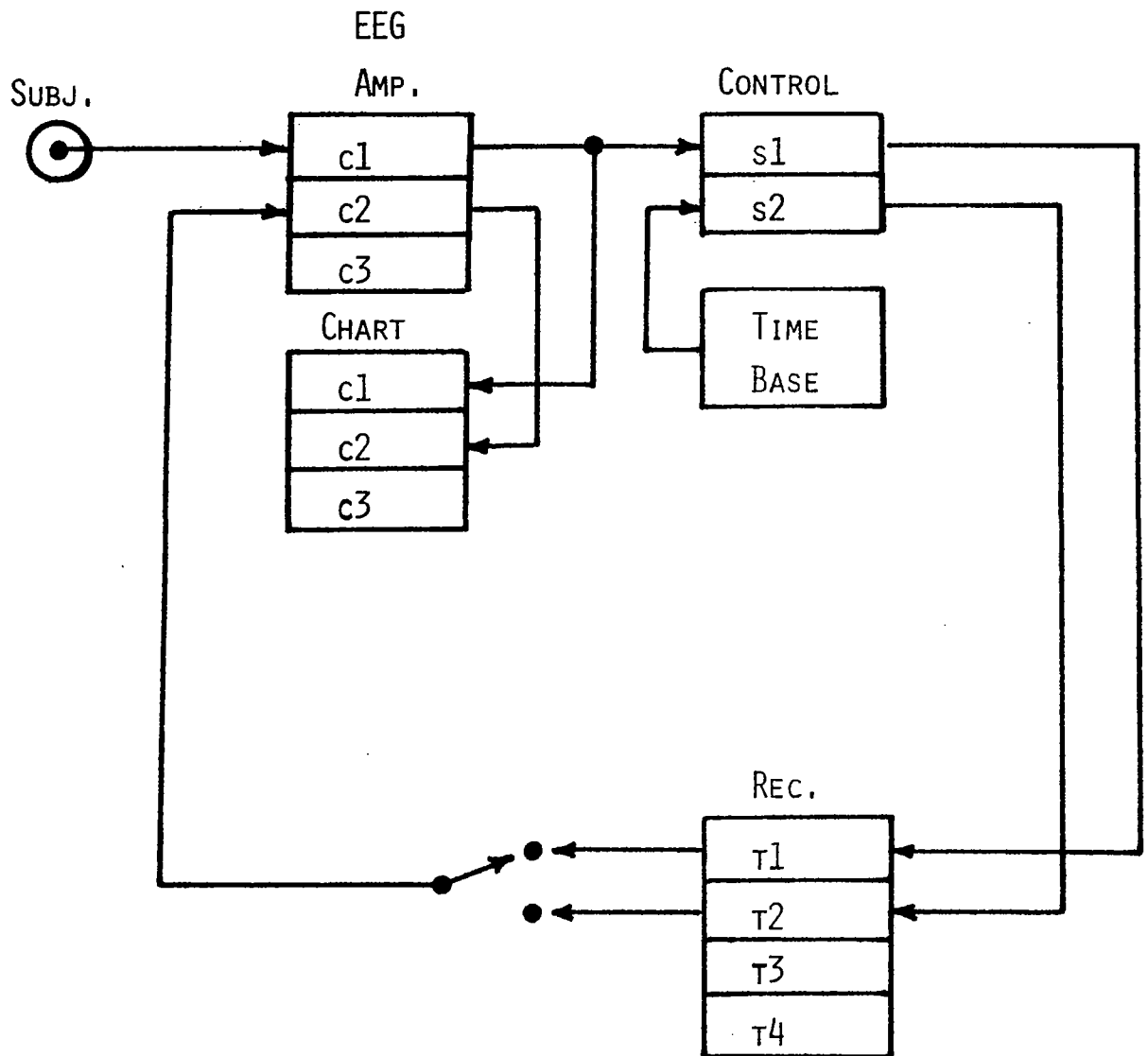

Schematic of the EEG data acquisition system. c1,c2,c3 refer to channels of the Grass Model 79 polygraphy. s1 and s2 refer to switches to transfer data to the tape recorder. τ1, τ2, τ3, and τ4 refer to the four track on the 1/4 in magnetic tape used by the Ampex Model SP 700 FM tape recorder.

FIG. 4

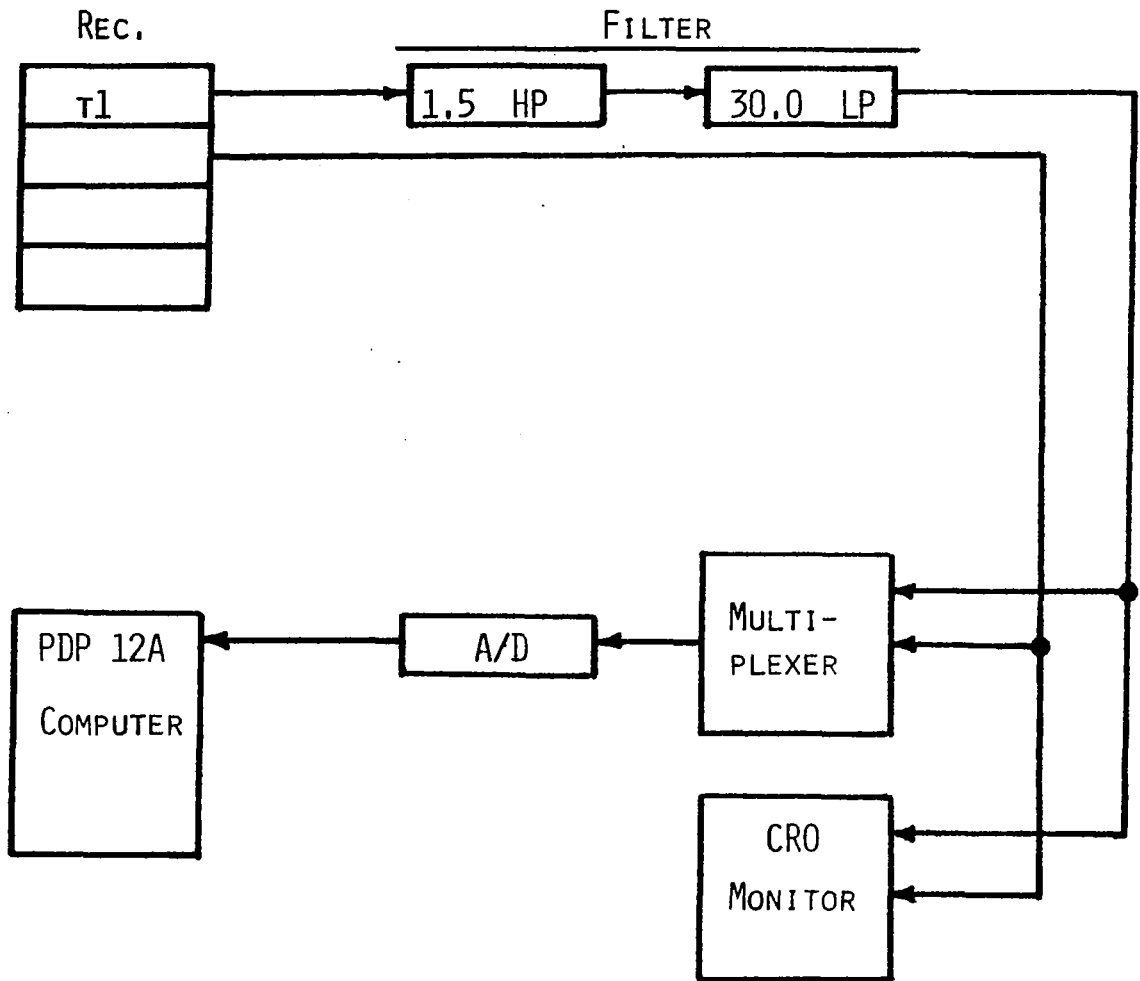

General arrangement for computer analysis of the recorded EEG data obtained during the night. t1, t2, t3, and t4 refer to recording tracks on the Ampex Model SP 700 FM tape recorder. t1 is the EEG data and t2 is the time base recording the occurrence of the jet aircraft flyover. A/D refers to the analog to digital convertor associated with the Digital Equipment Corporation PDP 12A computer system.

FIG. 5

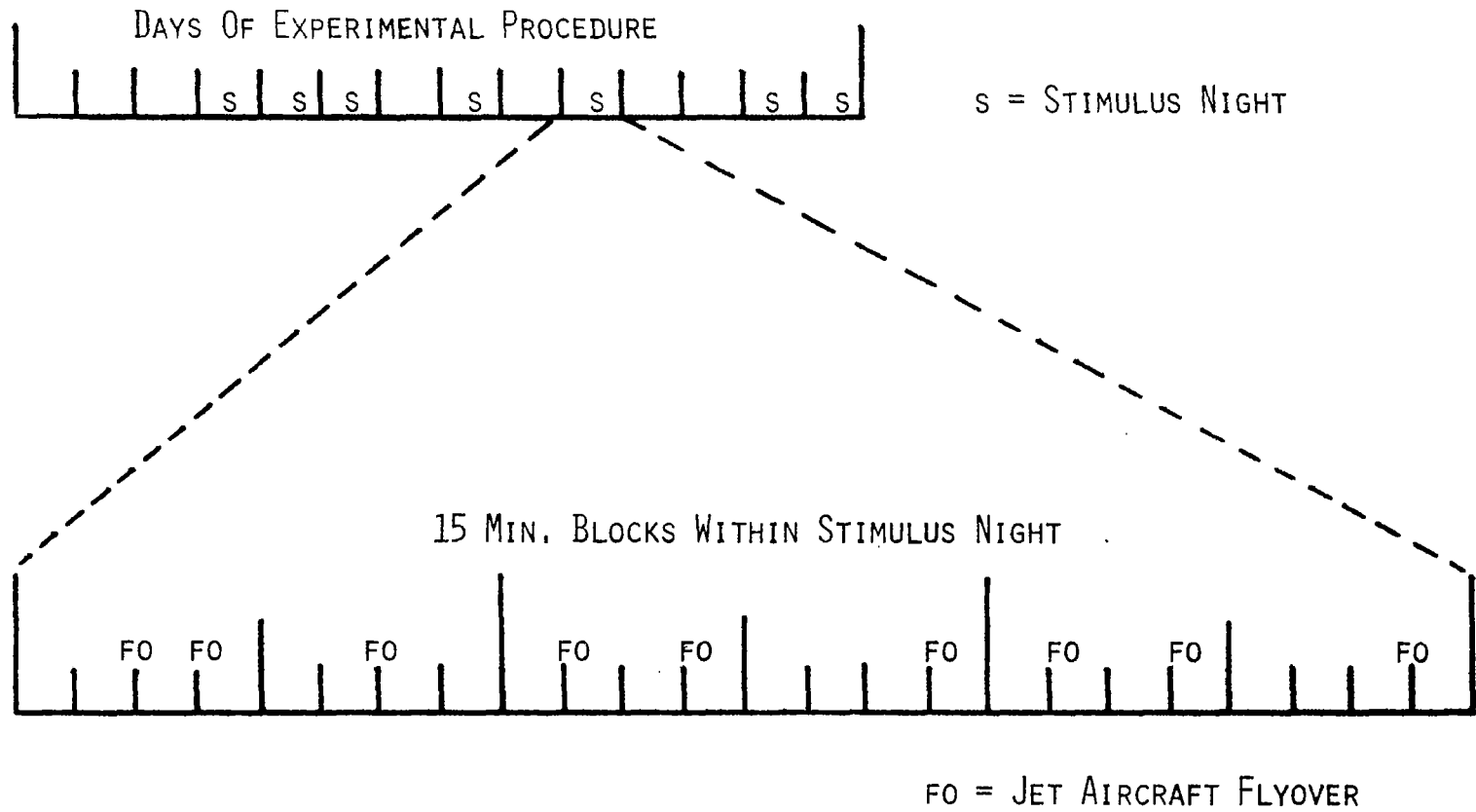

General time lines for a two week run on a single experimental subject and the presentation schedule for one of the stimulus nights.

FIG. 6

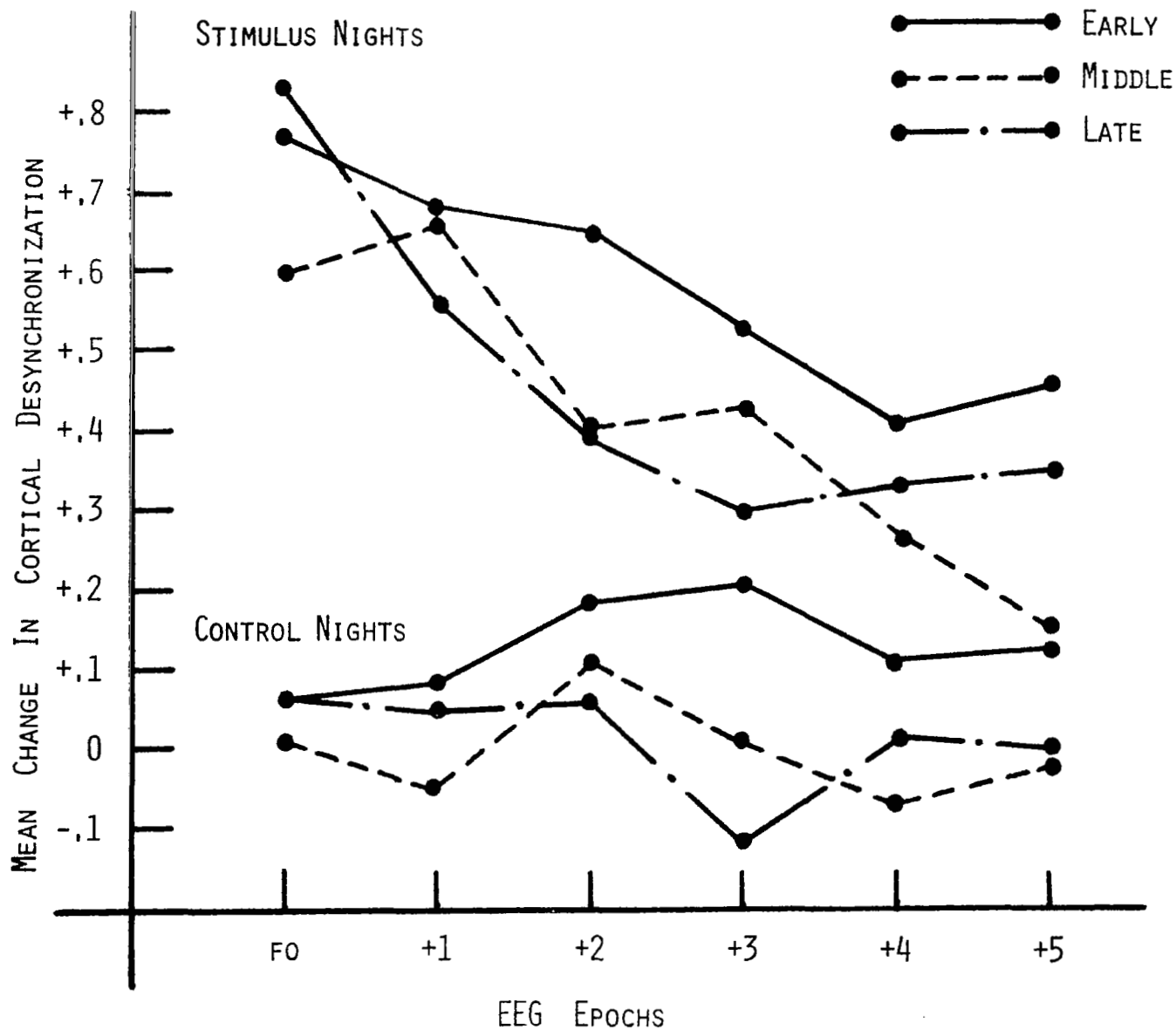
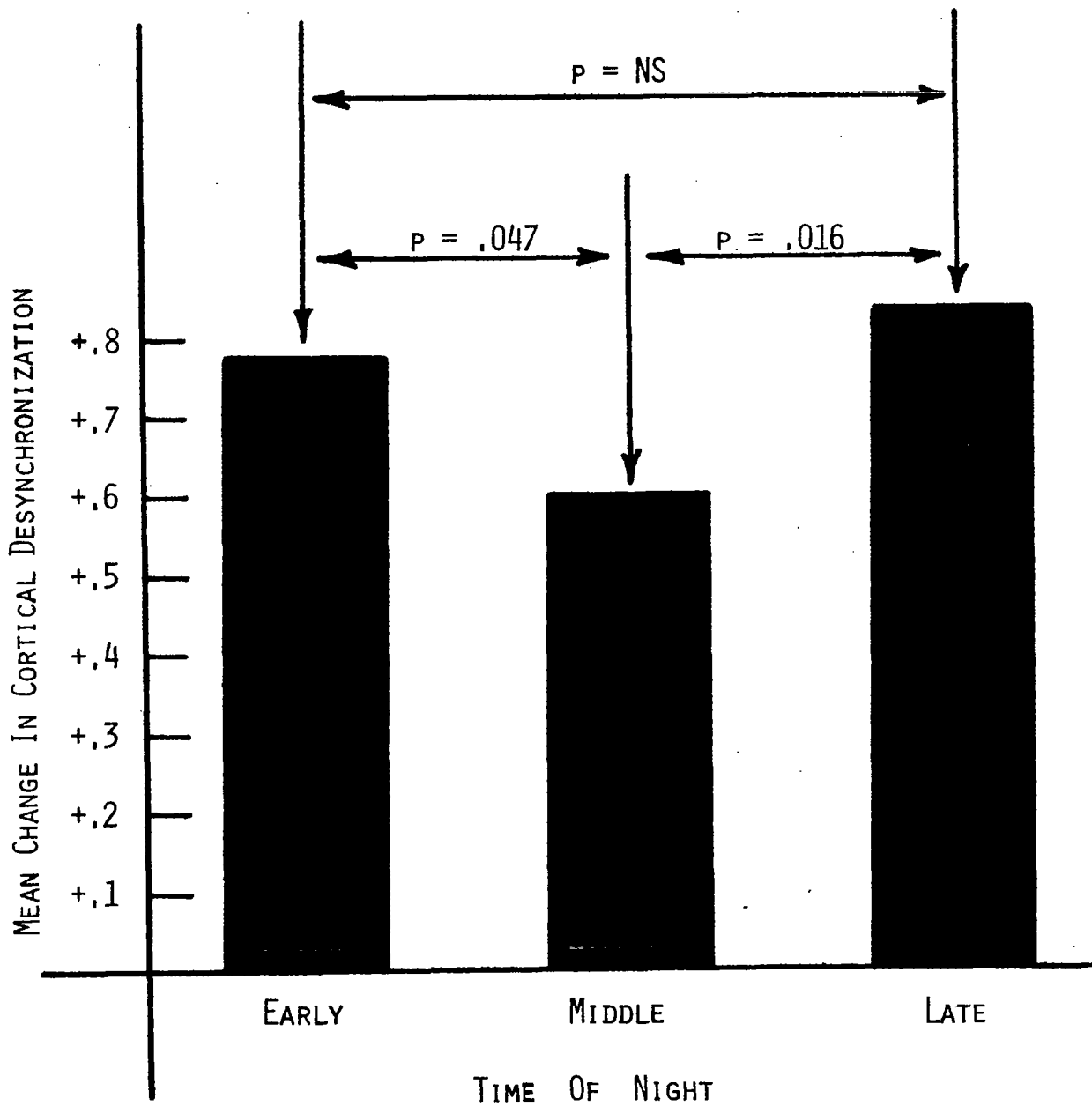

Figure presents the mean change in cortical desynchronization (increases in frequency indicated by positive numbers) that occurred in response to the Jet aircraft flyovers. The mean change was computed with regard to the 40 sec. EEG epoch just preceding the flyover.

FIG. 7



Mean time in cortical desynchronization and averaged over 2 hour thirds of a total nights sleep. The numbers above the bars give the probabilities that the plotted differences could be due to chance.

FIG. 8