

NASA CONTRACTOR REPORT

NASA CR-2047



NASA CR-2047

0.1

0061167



LOAN COPY: RETURN TO
AFWL (DOUL)
KIRTLAND AFB, N. M.

COMPARISON OF POLYESTER, FILM-YARN COMPOSITE, BALLOON MATERIALS SUBJECTED TO SHEAR AND BIAXIAL LOADING

by *R. J. Niccum*

Prepared by
G. T. SCHJELDAHL COMPANY
Northfield, Minn.
for Langley Research Center





0061167

1. Report No. NASA CR-2047	2. Government Accession No.	3. Recipient's Catalog No.	
4. Title and Subtitle COMPARISON OF POLYESTER, FILM-YARN COMPOSITE, BALLOON MATERIALS SUBJECTED TO SHEAR AND BIAXIAL LOADING		5. Report Date June 1972	6. Performing Organization Code
		8. Performing Organization Report No.	
7. Author(s) R. J. Niccum		10. Work Unit No. 815-20-09-03-05	11. Contract or Grant No. NAS1-10,750
9. Performing Organization Name and Address G. T. Schjeldahl Company Advanced Programs Division Northfield, Mn. 55057		13. Type of Report and Period Covered Contractor Report	
		14. Sponsoring Agency Code	
12. Sponsoring Agency Name and Address National Aeronautics and Space Administration Washington, D.C. 20546		15. Supplementary Notes	
16. Abstract <p>A series of candidate materials for use in large balloons was tested and their tensile and shear strength capabilities are compared. The tests were done in a cold box at -68°C (-90°F). Some of these materials were fabricated on a special machine called the Flying Thread Loom. This machine laminates various patterns of polyester yarn to a thin polyester film. The results show that the shear strength of materials change with the angle selected for the transverse yarns and substantial increases in biaxial load carrying capabilities compared to materials formerly used are possible. The loom capabilities and the test methods are discussed.</p>			
17. Key Words (Suggested by Author(s)) Balloon materials Low temperature testing Biaxial testing Flying Thread Loom		18. Distribution Statement Unclassified - Unlimited	
19. Security Classif. (of this report) Unclassified	20. Security Classif. (of this page) Unclassified	21. No. of Pages 51	22. Price* \$3.00

CONTENTS

	Page
1.0 SUMMARY	1
2.0 INTRODUCTION.	1
3.0 CYLINDER TESTING FACILITY	2
3.1 Basic Tester	2
3.2 Pressure Gages and Strain Gage Transducers	3
3.3 Calibration of the System.	9
3.4 Test Procedure	9
4.0 TECHNICAL DISCUSSION.	15
4.1 Candidate Material Selection	15
4.2 Cylinder Tests	16
5.0 CONCLUSIONS	30
APPENDIX A: Modifications to the G. T. Schjeldahl Company Flying Thread Loom.	31
APPENDIX B: Drawings and Bill of Materials for Cylinder Test Apparatus.	39
APPENDIX C: Multi-Axial Tensile Test Specification.	45

FIGURES

	Page
1. Cylinder Test Facility	4
2. Arrangement of Drive Mechanism Inside Specimen Mount	5
3. Interior Configuration of Cold Chamber	6
4. Typical Biaxial Test Record.	7
5. Specimen Mounting Details.	8
6. Axial Load Calibration System.	10
7. Calibration Set-Up of Cylinder Tester.	11
8. Torque Load Calibration System	12
9. Axial Force Calibration.	13
10. Torque Calibration	14
11. Yarn Geometries of Tested Materials.	17
12. Leno Woven Mesh Material Precoated Mylar GT-11 Material.	20
13. 82° FTL Material Roller Coated Yarn.	21
14. 45° FTL Material Roller Coated Yarns	22
15. 60° FTL Material Roller Coated Yarns	23
16. 60° FTL Material Precoated Mylar	24
17. 60° FTL Material Precoated Mylar Post Coated Laminate.	25
18. 60° FTL G127600 Preproduction Run.	26
19. 0.35 Mil High Elongation Mylar	27
20. Flying Thread Loom Laminator	33
21. Yarn Dispensing Drum and Creel Systems	34
22. Yarn Matrix and Carrier System	35
23. Finished Laminate.	36
24. Cylindrical Test Fixture Modification to -90°F	40
25. Biaxial Test Facility.	41
26. Cool Chamber Cylinder Test	42
27. Test Specimen.	47

TABLES

	Page
1. Number of Uniaxial Test Specimens.	18
2. Number of Cylinder Test Specimens.	19
3. Uniaxial Tensile Test Results.	29

COMPARISON OF POLYESTER, FILM-YARN COMPOSITE, BALLOON
MATERIALS SUBJECTED TO SHEAR AND BIAXIAL LOADING

By R. J. Niccum
G. T. Schjeldahl Company

1.0 SUMMARY

An existing device used to determine material characteristics at room temperature by testing specimens in cylindrical form was modified to allow cold temperature testing of materials of the type used in large, free flight balloons. The test specimen was surrounded with a chamber in which liquid nitrogen could be circulated to achieve a temperature of -68°C (-90°F).

Using this device, a series of candidate materials for use in such balloons was tested and compared on the basis of tensile and shear strength capabilities under various combined loads. Normal two-dimensional, strip tensile tests were also performed on each candidate material. Materials tested were a woven leno scrim laminated to a 0.35 mil high elongation Mylar as a standard of comparison and a series of geometric patterns of Dacron yarn matrices having transverse yarn angles ranging from 45° to 82° laminated to the same 0.35 mil high elongation Mylar. These materials were fabricated on a special device called the Flying Thread Loom (FTL) which makes it possible to vary the geometries of the yarn pattern. Though the primary purpose of this investigation was to analyze and compare the various material candidates, several necessary modifications to the Flying Thread Loom were made to accomplish some of these geometries. These modifications are discussed in Appendix A for the reader's reference.

The results show that the ability of the balloon material to accept shear loading can be increased markedly by varying the pattern of the reinforcement yarn without appreciably affecting the overall weight of the material nor degrading the tensile characteristics in the machine and transverse directions.

2.0 INTRODUCTION

In order to characterize the parachute operation in a simulated Martian environment and improve the confidence for success in the actual 1975 Viking mission, a series of tests have been devised in which the total aeroshell system will be elevated to a height of approximately 36.5KM (120,000') above the earth, accelerated to a desired Mach number and dynamic pressure condition, and the parachutes deployed. A balloon system was chosen to accomplish this since it represents the most efficient and economical platform from which to launch the aeroshell and conduct the parachute test at altitude.

Because the Viking mission is critical in terms of schedule and cost, the Martin Company and the Viking Program Office have analyzed the balloon system to be used in these tests in view of the reliability of the total system. This analysis shows that as the partially deployed balloon system passes through the strong wind region near the tropopause, it is possible that shear loads could be introduced in the balloon material in the region of undeployed gores adjacent to deployed gores. The question was asked, "What is the ability of a standard balloon material to support shear loads without failing?"

To answer this question, the G. T. Schjeldahl Company in conjunction with NASA Langley Research Center devised a test program to examine the properties of various candidate balloon materials at -68°C (-90°F) with the object of determining which of a series of practically attainable materials would exhibit the best capability for sustaining shear loads under various biaxial loads at this temperature.

This report discusses the test equipment and the cold chamber used, the method employed in testing the cylinder specimens, and the findings and conclusions reached. Also presented are strip tensile test results on the candidate materials at room temperature and -68°C (-90°F).

3.0 CYLINDER TESTING FACILITY

3.1 Basic Tester

A device previously developed and fabricated by the Schjeldahl Company for testing heavy, woven and coated materials in a cylindrical configuration at ambient conditions was modified to allow testing of free balloon materials at temperatures near -68°C (-90°F). This device is capable of introducing axial, hoop, and shear loads on the cylinder specimen.

It was originally intended only to modify the equipment for testing at non-ambient temperatures. However, the method of torque application on the original device (torque was applied to the rim of a ring with a cable) was found to be unwieldy for use with a cold chamber and was discarded in favor of another method described below.

Constraints on modifications to the existing device were that the chamber for effecting the temperature variation must be simple, quick to install, removable for access to the specimens, and permit return of the equipment to its original configuration. The final chamber design is a cylindrical tube 66 cm (26") in diameter by 182 cm (72") long, made of 0.25 cm (0.100 in.) aluminum sheeting. The tube contains an annular duct at each end and a duct across the top portion along the cylindrical length for circulating the nitrogen coolant. The chamber interior is lined with 5.07 cm (2") thick styrofoam. The chamber is fitted with four, casted legs for easy removal from the test fixture. Liquid nitrogen is introduced into the plenum area at the lower

portion of the chamber where it turns to vapor and is circulated by a fan at one end. The configuration of the device is shown in Figures 1 through 3. Detailed drawings and a bill of material are presented in Appendix B.

Temperature is controlled by a sensing unit and thermocouples which are located at the various stations about the internal portion of the duct and are monitored on a recorder. No difficulty was experienced in achieving a uniform temperature of -68°C (-90°F) throughout the chamber.

Axial load in the test fixture is applied by air pressure in a 12.7 cm (5") diameter cylinder with a 38.1 cm (15") stroke. This cylinder produces loads of about $87.0 \times 10^2 \text{ N/M}$ (50 lbs per inch) on the size specimen to be tested. A rotary air cylinder is provided to apply the torsional loads. This is located on the shaft of the axial piston and is capable of providing approximately 621 N-M (5500 lbs-in) of torque at $826 \times 10^3 \text{ N/M}^2$ (120 psi) working pressure. Hoop load on the cylinder specimens is provided by internal pressure applied to the interior of the cylinder test specimen.

3.2 Pressure Gages and Strain Gage Transducers

Pressure gages and strain gage transducers were connected to the pressure lines providing the power source to the cylinders. Load settings were made by referring to dial pressure gages. Time variation of internal pressure, axial pressure, and torquing pressure were recorded on a Honeywell Type 906B oscillograph during each test. The chart traces were later reduced to axial loads and torques. A typical trace is shown in Figure 4.

The cylinder specimens were fabricated from a single sheet of the appropriate material seamed lengthwise into a cylinder. An identical dummy seal was made diametrically opposite to the actual seal to achieve symmetry. Strain data was collected by cables attached to the cylinder which monitored the relative position of 2 points on the cylinder which lie in a plane containing the axis at zero load and are displaced due to the shear deformation in the fabric. The change in position of these points was fed into the recorder by potentiometers whose wipers were attached to the cables. Axial strain was monitored on a gage connected to the cylinder producing axial force. The diameter of the test cylinder was monitored in a similar manner with a cable and potentiometer.

Attachment of the cylinder specimens to the test fixture required a strict procedure. The fixed and movable specimen mounts were made in the form of discs, 35.6 cm (14 inches) in diameter, as shown in Figure 5. A rubber gasket material was attached to the rims of these discs to seal the ends of the cylindrical test specimen. The specimen was fitted onto this "mangle" like device, another piece of gasket material slipped over the specimen on each end and the layers clamped to the end discs by large hose clamps. This provided a pressure-tight seal as well as a mechanical constraint during the test.

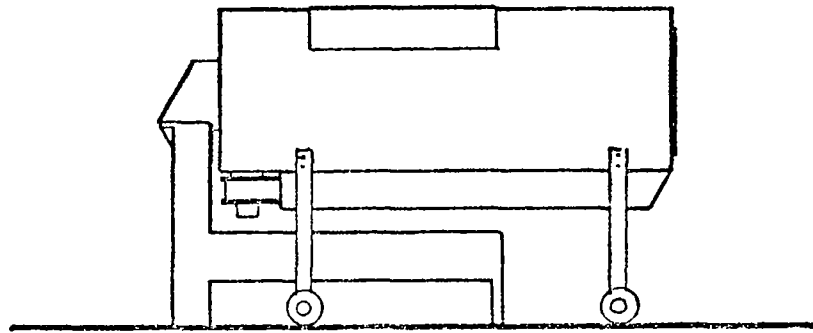

(a)

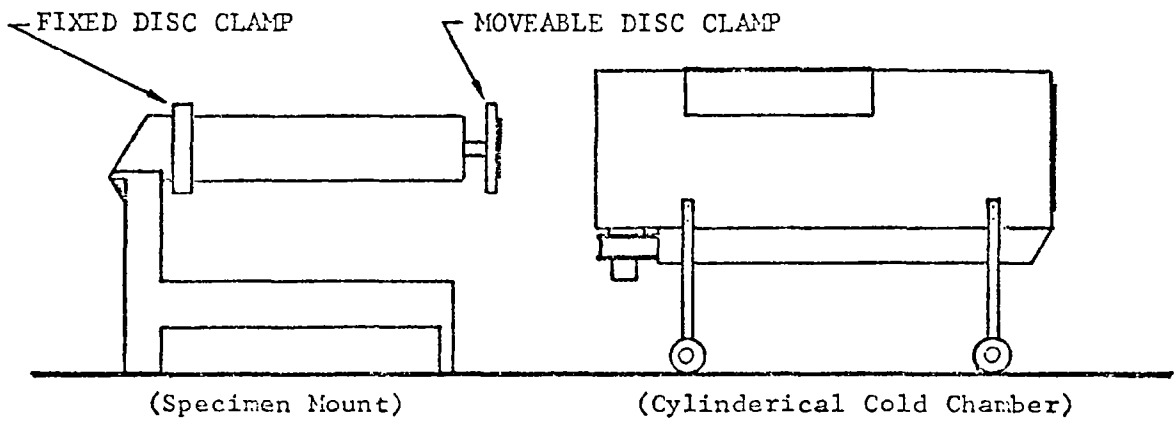

(b)

FIGURE 1 CYLINDER TEST FACILITY

(a) Assembled for Testing

(b) With Cold Chamber Removed, for
Access to Test Specimen

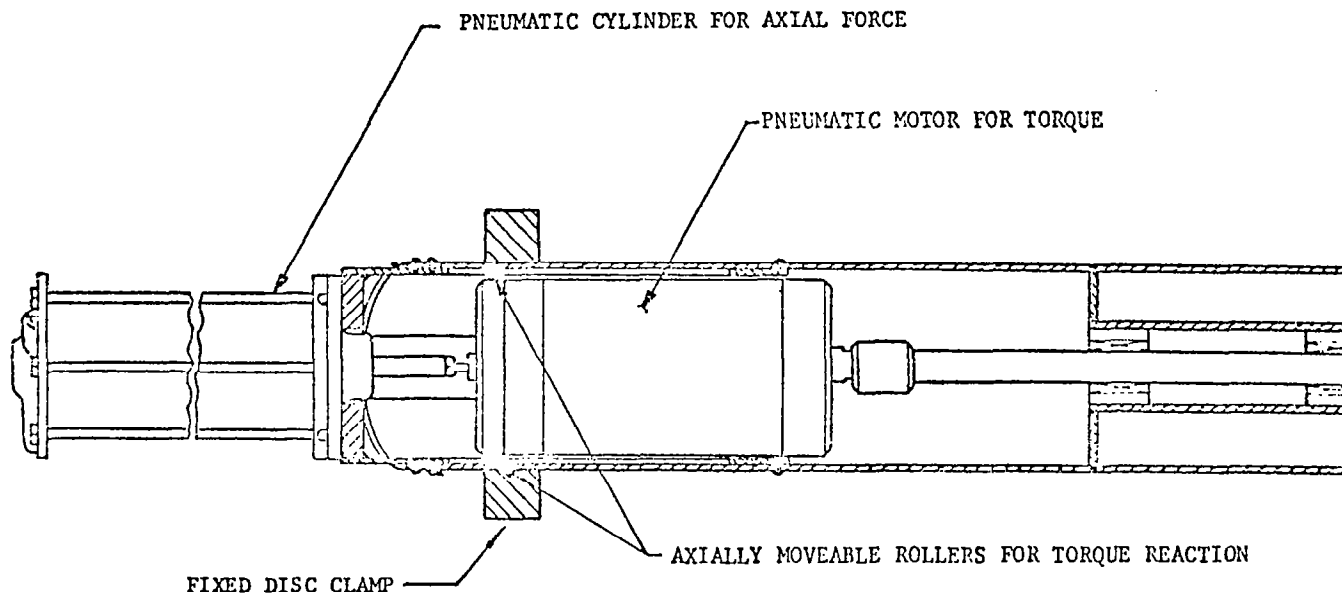

FIGURE 2 ARRANGEMENT OF DRIVE MECHANISM INSIDE SPECIMEN MOUNT

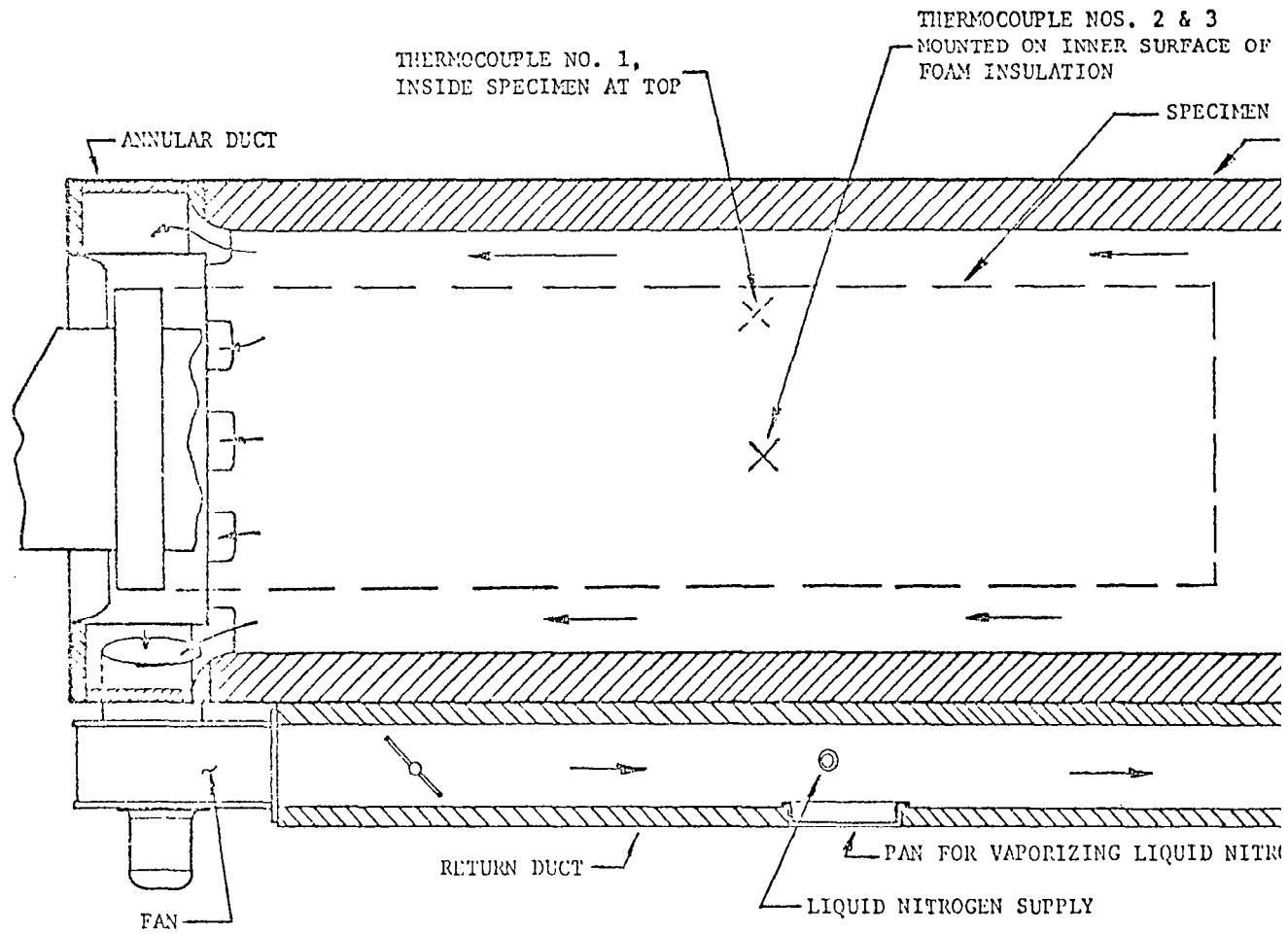

FIGURE 3 INTERIOR CONFIGURATION OF COLD CHAMBER

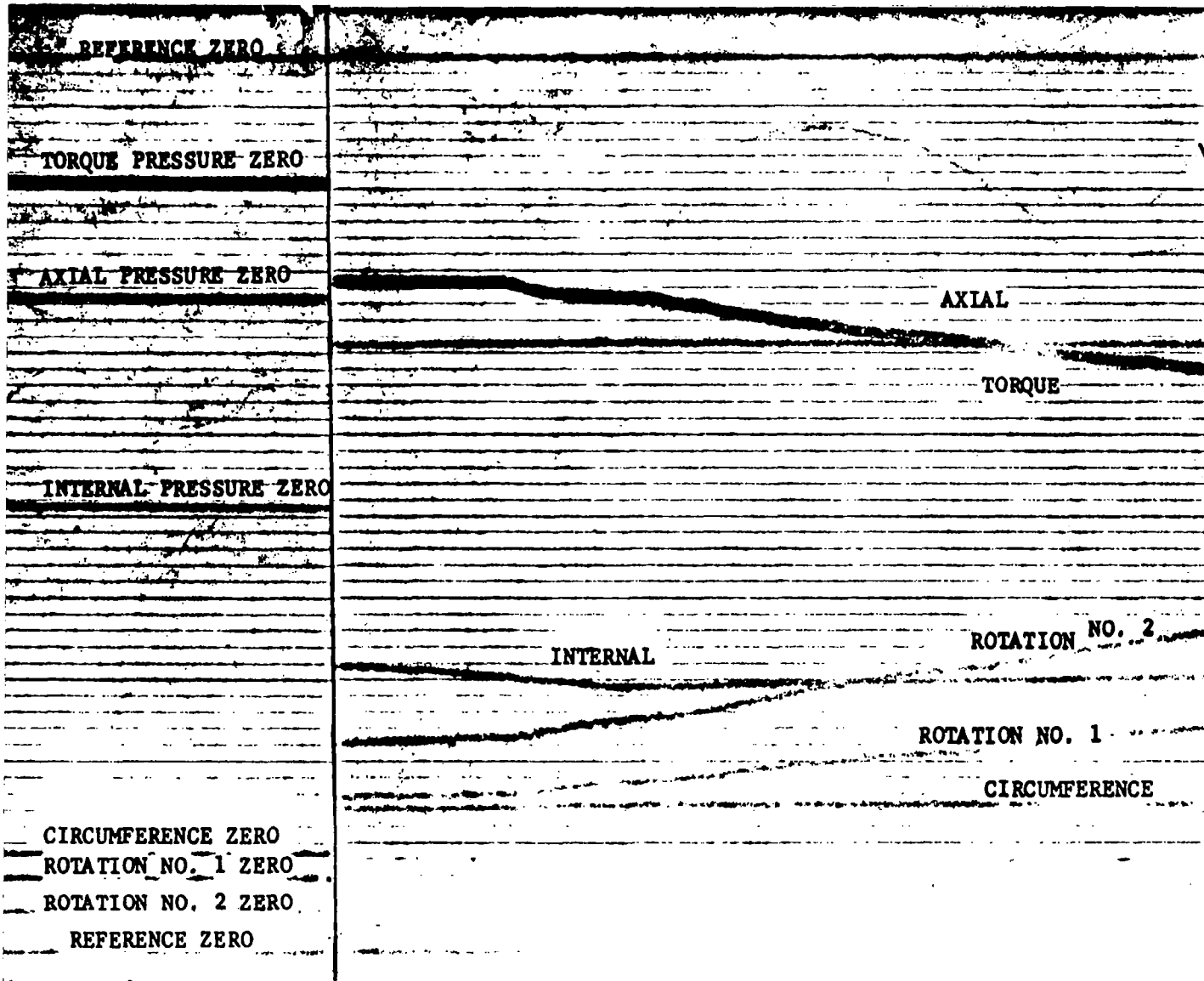

CHART SPEED 0.4 IPS, TEST 37- GT 11-TD

FIGURE 4. TYPICAL BIAXIAL TEST RECORD

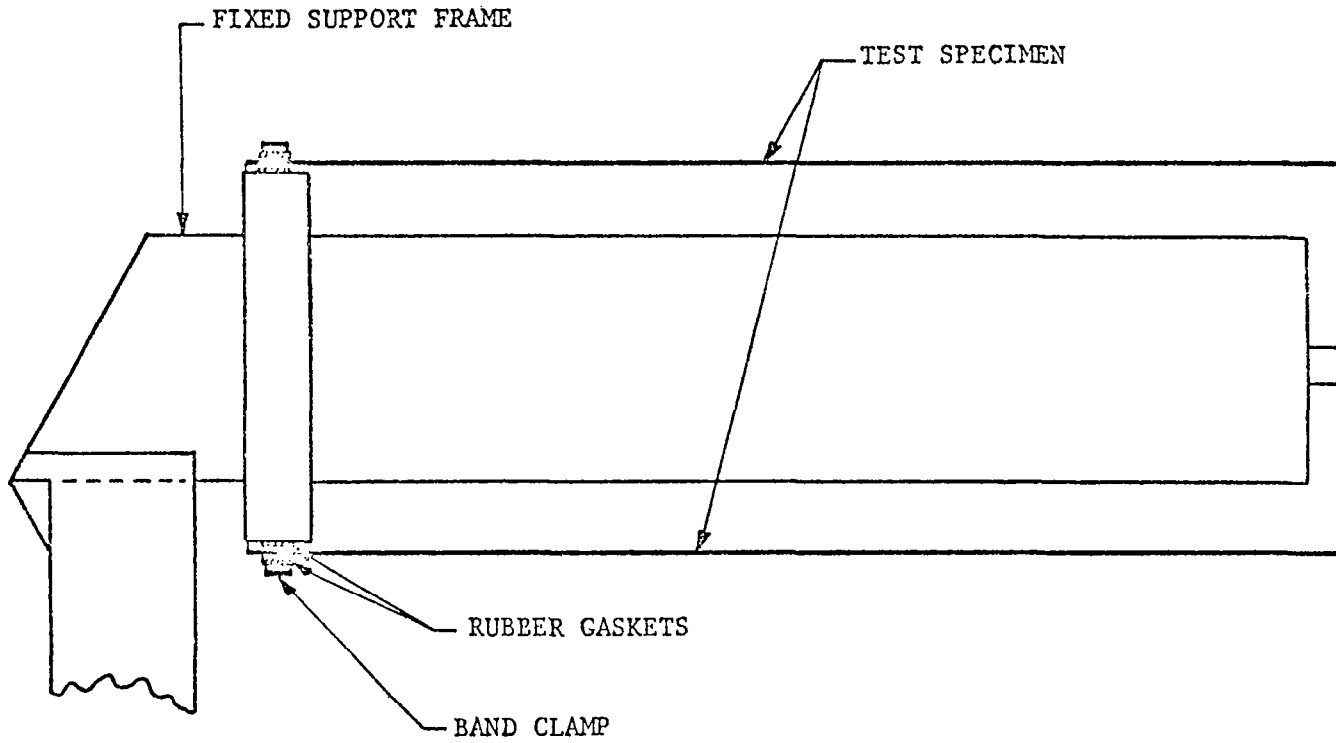

FIGURE 5 SPECIMEN MOUNTING DETAILS

3.3 Calibration of the System

The axial cylinder was calibrated through its range of operation by mounting a load cell, as shown in Figure 6, and the photos in Figure 7, so the pistons react against a bar with a known moment arm attached to the load cell.

The torque cylinder was calibrated by attaching a spring balance to a fixed length lever arm connected to the free disc end of the test apparatus, as shown in Figure 8. By applying air pressure to the torque cylinder, the torque output could be measured. Figures 9 and 10 show calibration curves of the axial and torque cylinders, and the extremely good linearity through the range of operation. Repetition of the calibration showed the load device to be very stable.

3.4 Test Procedure

Biaxial load tests. — The test procedure is only summarized here. A complete description of the test procedure in specification form is presented in Appendix C of the report.

Specimen preparation. — The material to be used for the test specimens was examined for local damage such as foldovers and wrinkles that might yield a false result when tested. Samples were carefully cut with a razor blade on a cork backing material to ensure clean edge lines. The cylinders were fabricated from a mylar sheet formed into a tube with two seals diametrically opposed. These seals were identical to those used in the full scale balloons to duplicate the effect of joints on the stresses from one panel to another. The two seals were required to maintain symmetry when testing.

Test sequence. — The specimen was carefully mounted by sliding it on to the open end of the tester after having aligned the free end disc with the appropriate index mark. The gaskets were carefully placed over the ends and lightly tightened. 103-137KN/M² (15 to 20 psi) of air pressure was applied to the axial load cylinder to take out wrinkles and generally align the specimen with the machine.

The metal clamps were placed over the gaskets and securely tightened. At this point an internal pressure of about 7500 N/M² (30 inches of water) was applied using dry nitrogen and the specimen inspected for minute leaks. Small leaks were sealed with pressure sensitive tape before beginning the test.

The cold chamber shroud was positioned over the mounted specimen, the liquid nitrogen supply attached to the cold chamber and the thermocouple wires placed at the various stations within the chamber for monitoring temperature. The appropriate cables were attached between the potentiometers and the tabs on the cylinder. Liquid nitrogen was introduced and temperature monitoring begun. When the temperature in the system had stabilized at $-68^{\circ}\text{C} + 3^{\circ}$ ($-90^{\circ}\text{F} + 5^{\circ}$), the load was applied by first raising the internal pressure to the desired test level, and then applying the axial load, then the torque. (During this period, data was monitored visually on gages and recorded on the

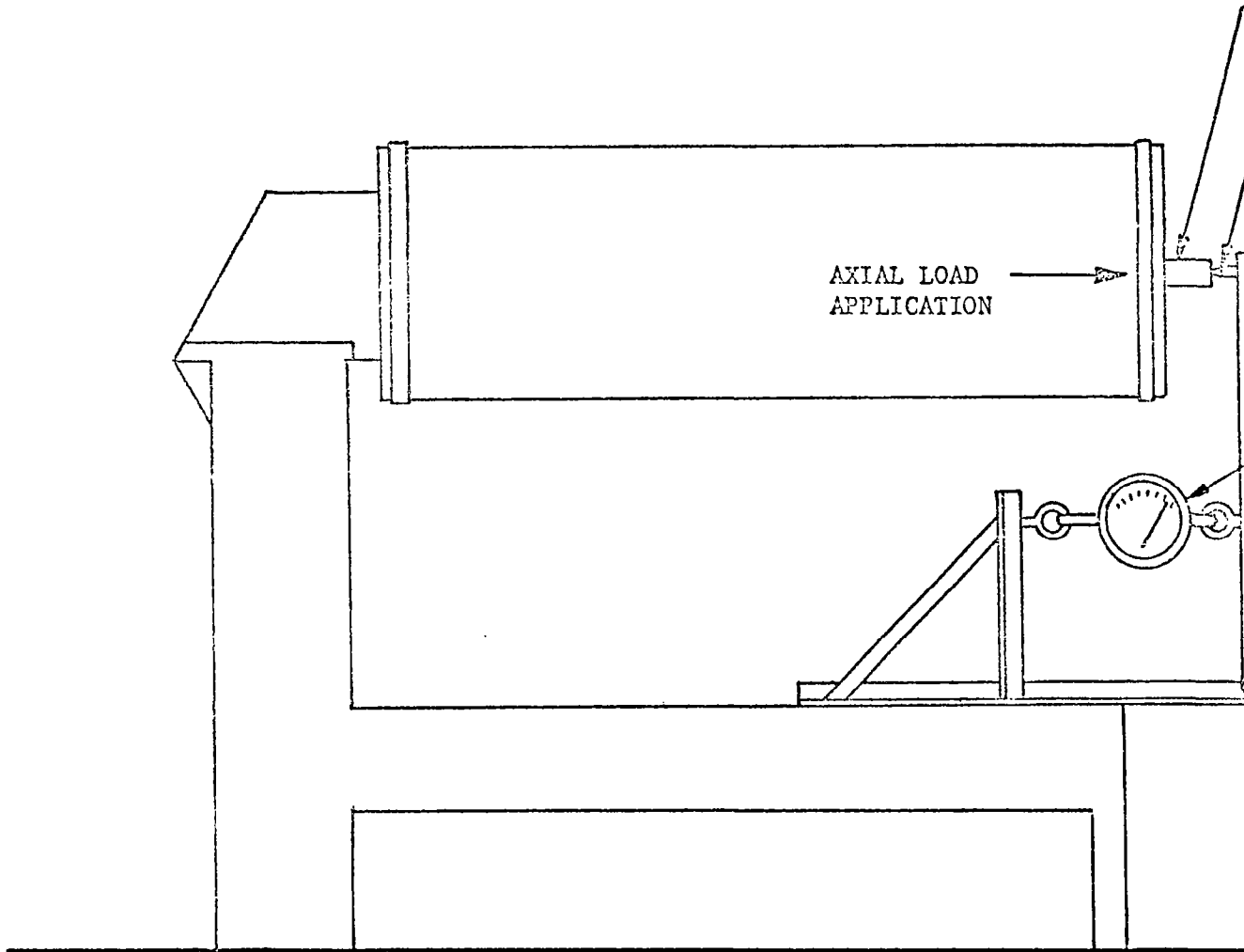

FIGURE 6 AXIAL LOAD CALIBRATION SYSTEM

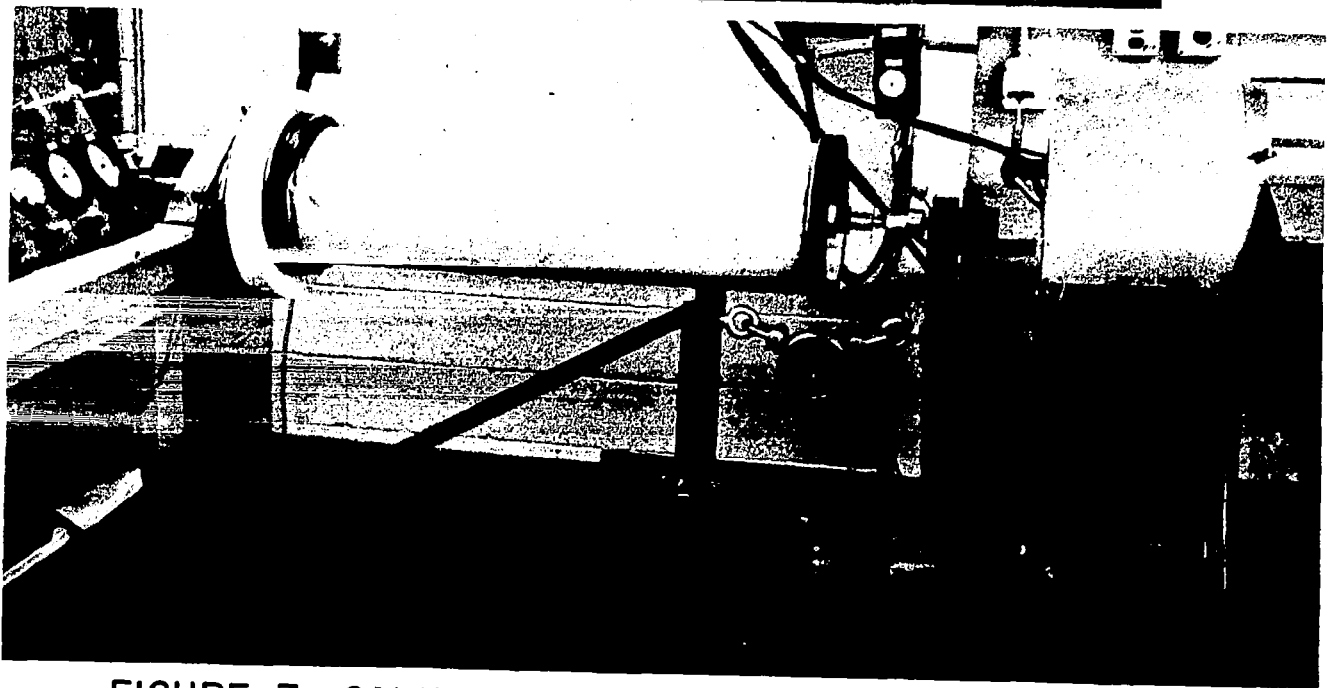
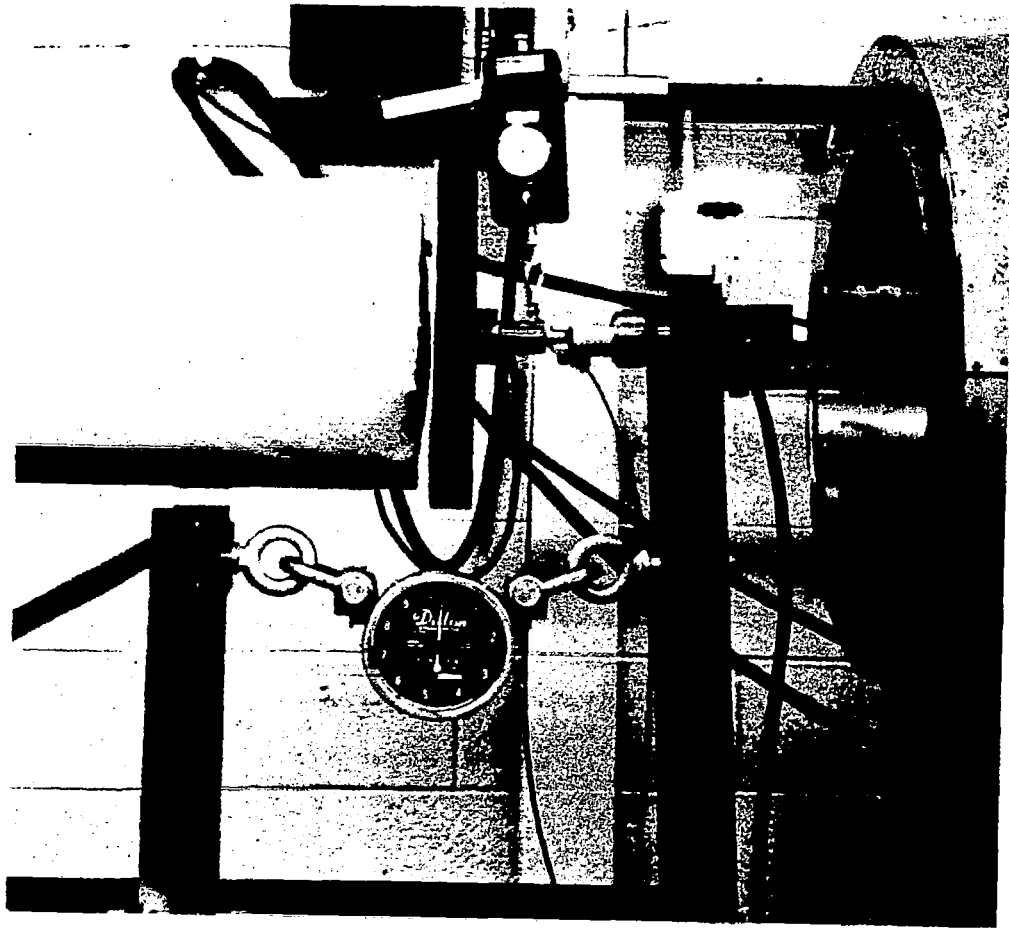

FIGURE 7, CALIBRATION SET-UP OF CYLINDER TESTER

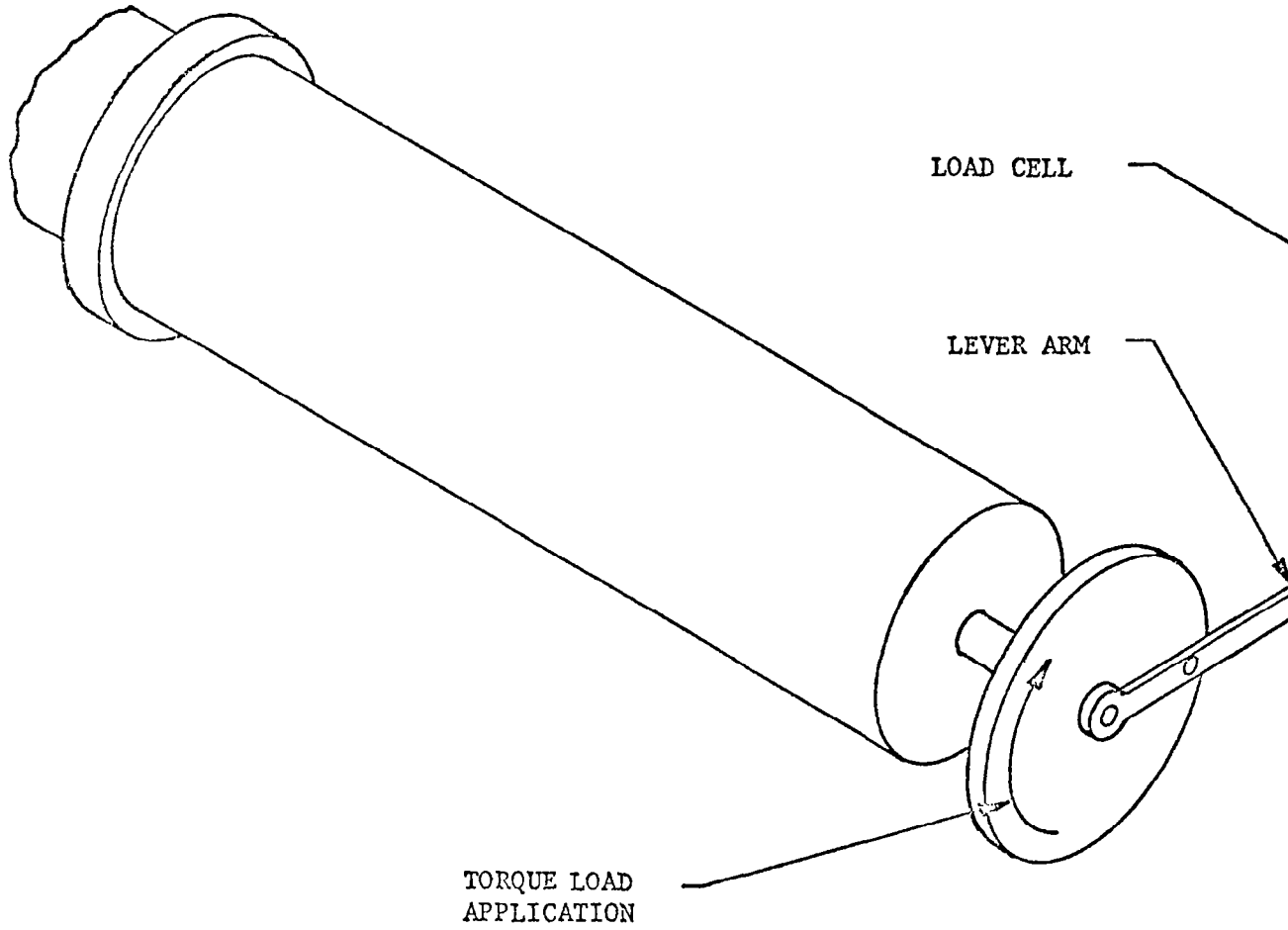

FIGURE 8 TORQUE LOAD CALIBRATION SYSTEM

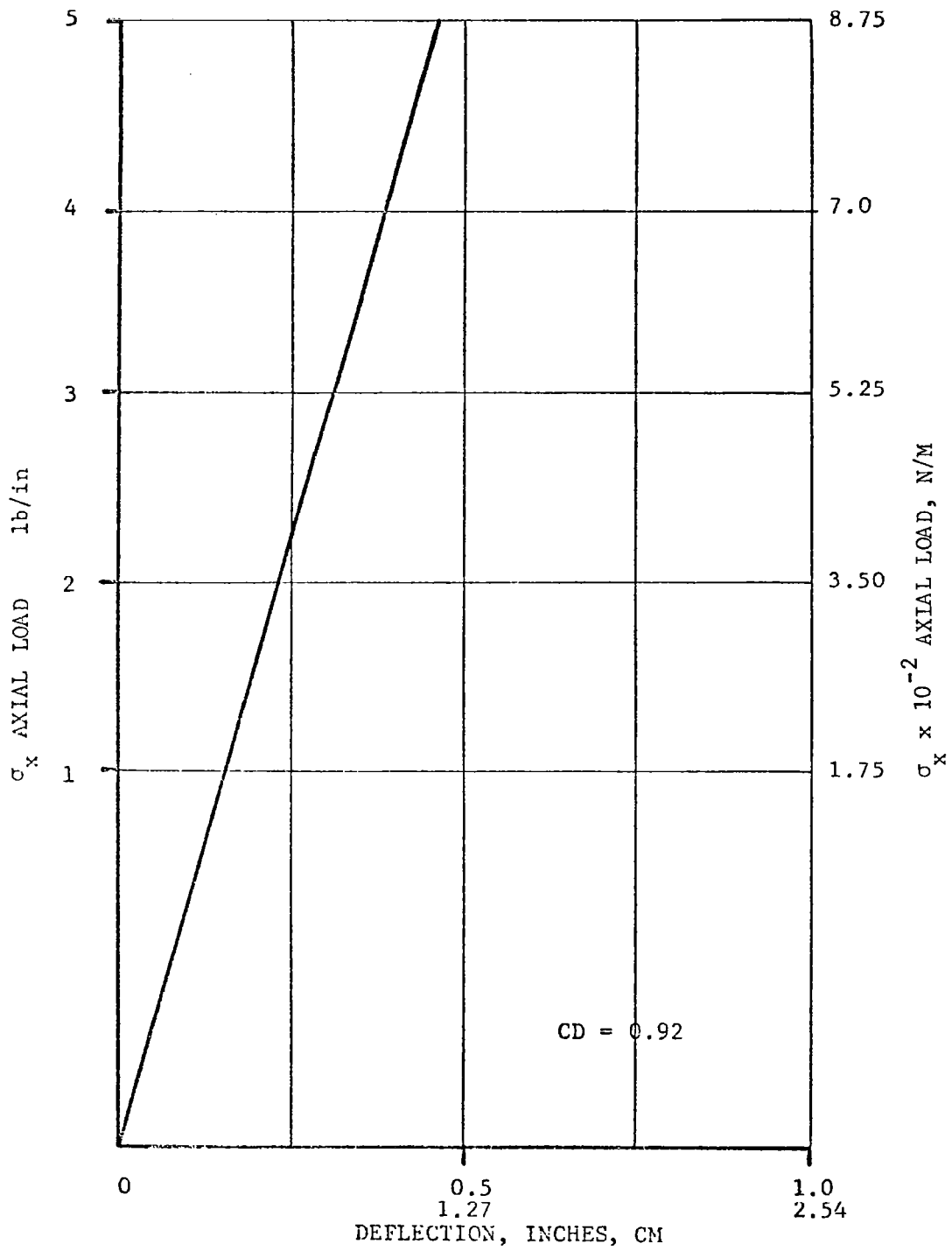

FIGURE 9 AXIAL FORCE CALIBRATION

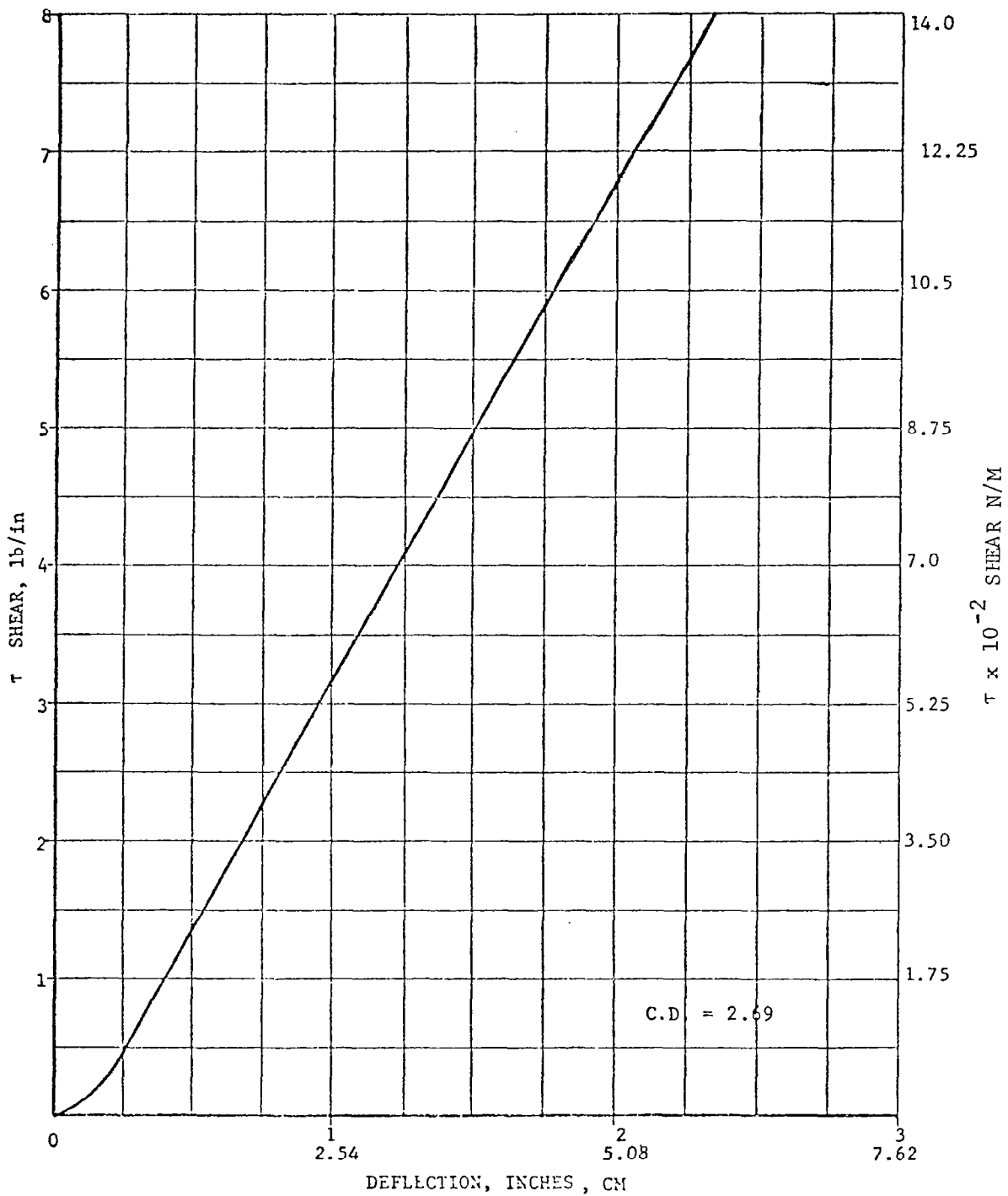

FIGURE 10 TORQUE CALIBRATION

oscillograph). The torque was increased until failure occurred.

The specimen was then removed from the chamber, inspected to determine the mode of failure and whether the failure was of a general nature, or if there was a mistest. If the test was judged valid, the data was reduced from the recorded oscillograph trace.

Uniaxial load tests. — The uniaxial or strip tensile tests were performed using an Instron testing machine fitted with a cold chamber to facilitate testing at non-ambient conditions. Samples tested were 2.54 cm (1 inch) wide by approximately 20.3 cm (8 inches) long. Tests were performed on specimens cut in machine (MD) and transverse (TD) direction and at 45° to the right and left on the MD.

Tests were conducted at -68°C (-90°F) with jaw separation of 5.08 cm (2 inches) and a pull rate of 8.45×10^{-2} cm/sec (2 inches/minute).

4.0 TECHNICAL DISCUSSION

4.1 Candidate Material Selection

Using the equipment described above, testing was conducted on the material candidates for Viking balloons. The standard material used for comparison, GT-11, is made from a leno weave of Dacron yarn with 1.575 440 d yarns/cm (four 440 denier yarns to the inch) in the transverse direction, by 2.355 440 d yarns/cm (six 440 denier yarns to the inch) in the machine direction. This rectangular mesh is laminated to 0.35-mil thick Mylar previously coated with a polyester adhesive.

The following materials were tested and compared to this standard:

(a) An "82°" Flying Thread Loom (hereinafter called FTL) material (GT-111-4) comprised of 440 denier transverse yarns intersecting 1000 denier MD longitudinal yarns at approximately 82° with the MD yarns spaced at 0.788/cm (2 per inch).

(b) An experimental "45°" FTL material comprised of 440 denier, transverse yarns intersecting 1000 denier MD yarns at 45° and spaced 1.252 cm (0.5 inches) apart, with machine direction yarns of 1000 denier also spaced 1.252 cm (0.5 inches) apart.

(c) An experimental "60⁰" FTL material with a transverse yarn spacing of 0.686/cm (1.74/in) and 1000 denier longitudinal yarns spaced 0.788/cm (2 to the inch).

(d) Several other variations of the 60⁰ FTL material were tested having the same 440 denier transverse yarn pattern but 1300 or 1400 denier machine direction yarns spaced 0.788/cm (2 to the inch). These two configurations were laminated to adhesive coated Mylar rather than coating the yarns themselves with the adhesive as in (a) through (c).

(e) To determine the effects of the Mylar alone, 0.35 mil high elongation film without yarn reinforcement was tested.

Sketches of the various candidates are presented in Figure 11. A table of the uniaxial and biaxial load tests conducted on these materials is presented in Tables 1 and 2.

4.2 Cylinder Tests

During the early stages of testing, cylinders were fabricated either with the machine direction yarns along the axis of the cylinders or perpendicular to it. The former were called "MD" cylinders and the latter "TD". This was done in an effort to identify and eliminate the effect of seams in the test specimens. However, it was found that the high internal pressures necessary to simulate a machine direction load on TD cylinders completely overshadowed the effect of seams and strongly biased the results when TD cylinders were used. Further testing of the transverse direction oriented cylinders was abandoned.

Seam strength itself was a problem in the higher test load ranges due to the fact that the seam tapes had a higher modulus than the parent material and would reach their ultimate strength before the rest of the cylinder. Attempts were made to relieve the load on the seams and to distribute the load into the test material in the cylinder. These efforts were unsatisfactory. At high axial loads, with varying hoop load and no torque, the results presented are not indicative of the maximum strength of the material without seams.

Results of the cylinder tests are presented in Figures 12 through 19. The referenced figures contain failure stress data only, since the strain data collected was inconsistent. This may in part be due to the fact that deflections were small and thus errors due to friction and/or hysteresis are relatively large. It can be seen that the capacity of the rectangular mesh material to support shear is little better than the capability of the Mylar alone. Performance of the FTL materials, particularly that of the

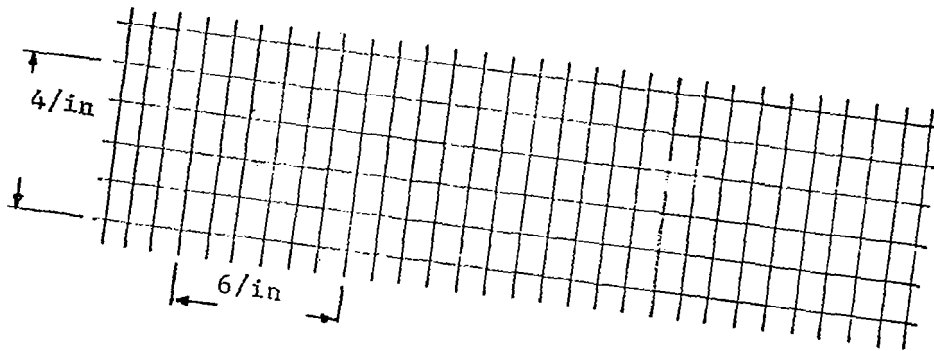

Leno Weave
(GT-11)
Standard of
Comparison

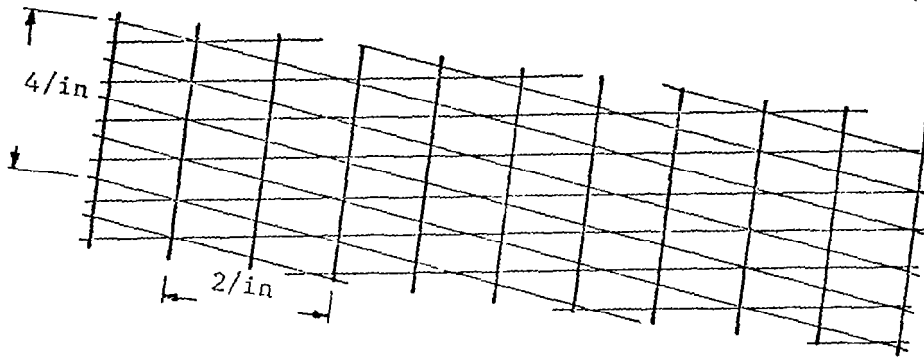

82° FTL
(Gt-111-4)

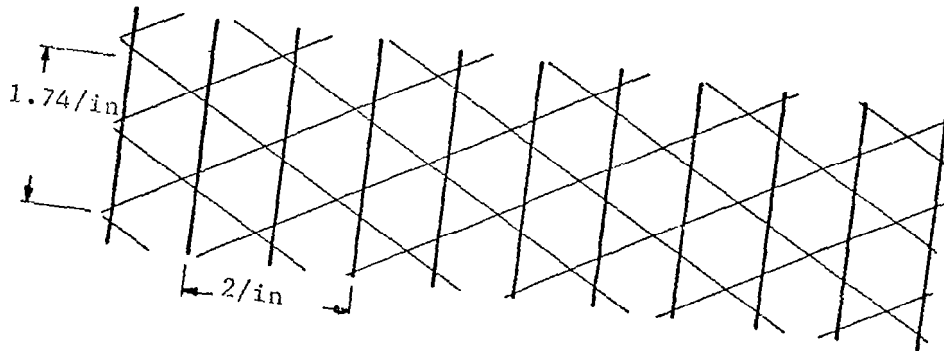

60° FTL

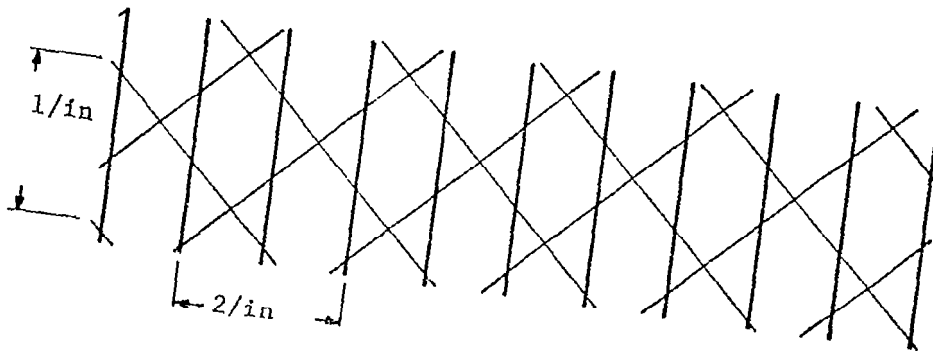

45° FTL

FIGURE 11 YARN GEOMETRIES OF TESTED MATERIALS

TABLE 1
NUMBER OF UNIAXIAL TEST SPECIMENS

Material	Angle of pull-axis of specimen with respect to machine operation			
	-45	0	+45	90
GT-11 Isotropic.	10	10	10	10
GT-111 Isotropic	10	10	10	10
Plain Isotropic Mylar	10	10	10	10
Hand Layed GT-111-4 Isotropic. .	10	10	10	10
Hand Layed 45° Laminate	10	10	10	10
Hand Layed 60° Laminate	10	10	10	10
Candidate FTL 45° Laminate	10	10	10	10
Candidate FTL 60° Laminate	10	10	10	10
Candidate FTL 60° Laminate (Precoat w/ 1000 d MD Yarns)	*10	10	*10	0
Candidate FTL 60° Laminate (Precoat w/ 1440 d MD Yarns)	*10	10	*10	0
Selected FTL 60° Laminate (Precoat w/ 1300 d MD Yarns)	*10	10	*10	0

*60° TD Machine Direction

TABLE 2

NUMBER OF CYLINDER TEST SPECIMENS

	Material Machine Direction Aligned along Cylinder Axial Direction (MD)	Transverse Material Direction Aligned along Axial Direction (TD)
GT-11 Isotropic	9	29
GT-111-4 Isotropic	14	18
Plain Isotropic Mylar	7	-
GT-111-4 Hand Layed	1	1
45° Laminate Hand Layed	1	1
60° Laminate Hand Layed	1	1
Candidate FTL 45°	21	3
Candidate FTL 60°	4	22
Candidate FTL 60° (Precoat w/ 1000 d MD Yarns)	10	4
Candidate FTL 60° (Precoat w/ 1440 d MD Yarns)	25	1
Selected FTL 60° (Precoat w/ 1300 d MD Yarns)	10	-

MD TD
 440 x 440 denier yarns

0 - 3.50 x 10 ² NT/M	○	Hoop	○	0-2 #/in.
3.5 - 7 x 10 ² "	△		△	2-4 #/in.
7 - 10.5 x 10 ² "	□		□	4-6 #/in.
10.5 - 14 x 10 ² "	◇		◇	6-8 #/in.
14 - 17.5 x 10 ² "	⊗		⊗	8-10 #/in.
17.5 - 21 x 10 ² "	⊠		⊠	10-12 #/in.
21 - 24.5 x 10 ² "	⊡		⊡	12-14 #/in.

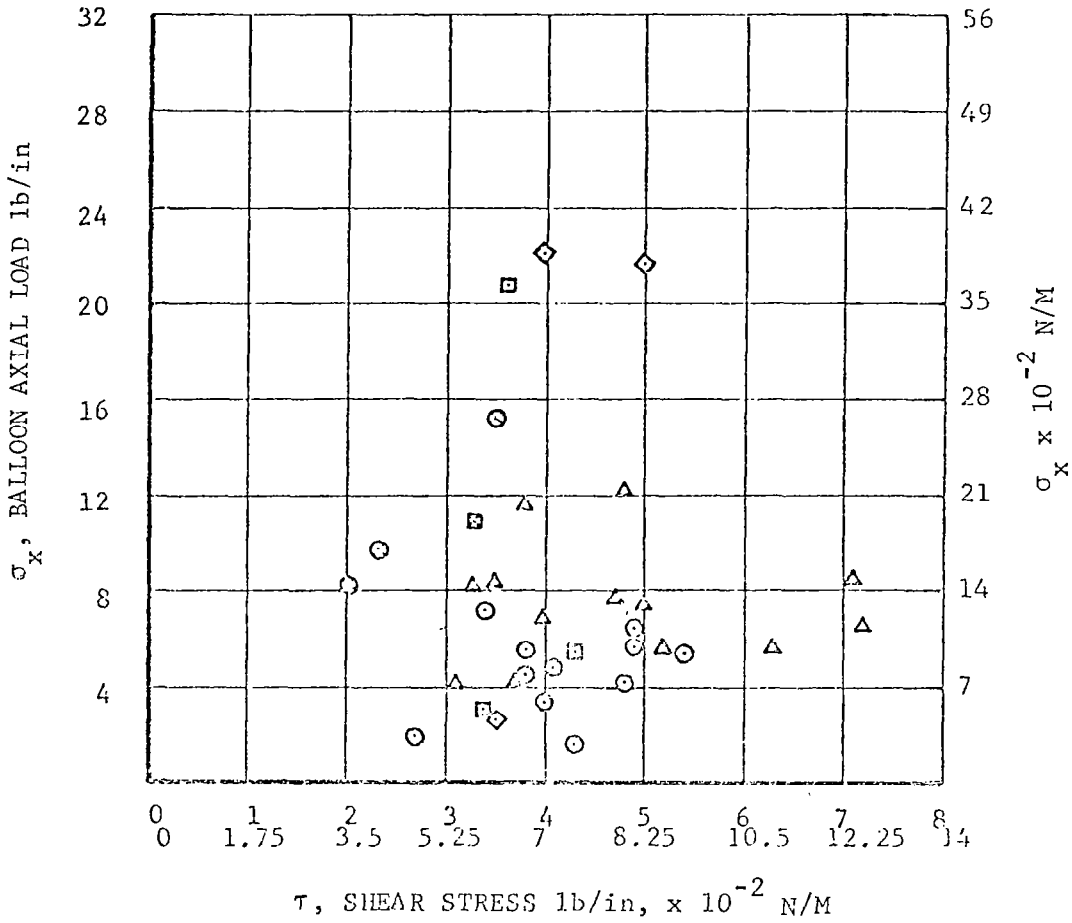

FIGURE 12 LENO WOVEN MESH MATERIAL
 PRECOATED MYLAR
 GT-11 MATERIAL

MD TD
1000 x 440 denier yarns

	Hoop
0 - 3.50 x 10 ² NT/M	○ 0-2 #/in.
3.5 - 7 x 10 ² "	△ 2-4 #/in.
7 - 10.5 x 10 ² "	□ 4-6 #/in.
10.5 - 14 x 10 ² "	◇ 6-8 #/in.
14 - 17.5 x 10 ² "	⊗ 8-10 #/in.
17.5 - 21 x 10 ² "	⊠ 10-12 #/in.
21 - 24.5 x 10 ² "	⊡ 12-14 #/in.

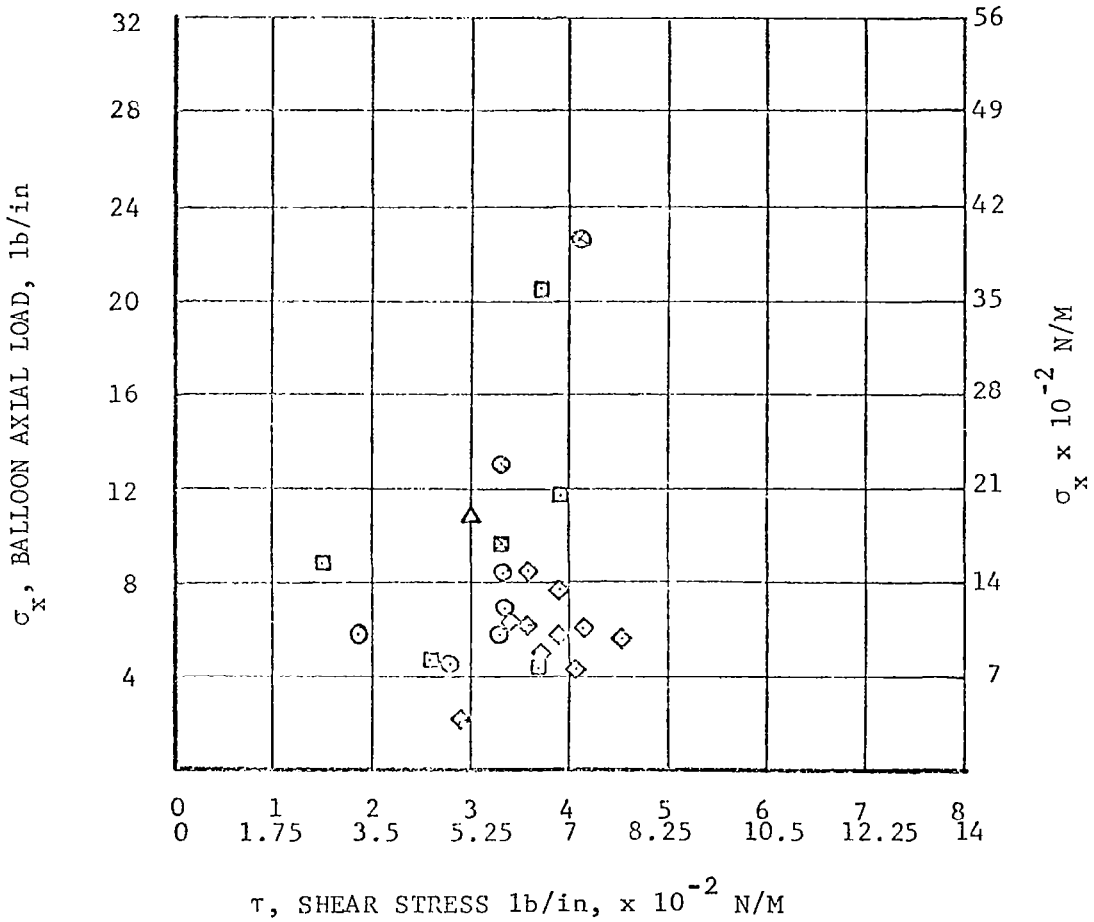

FIGURE 13 82° FTL MATERIAL ROLLER COATED YARN
GT-111-4X MATERIAL

MD TD
1000 x 440 denier yarns

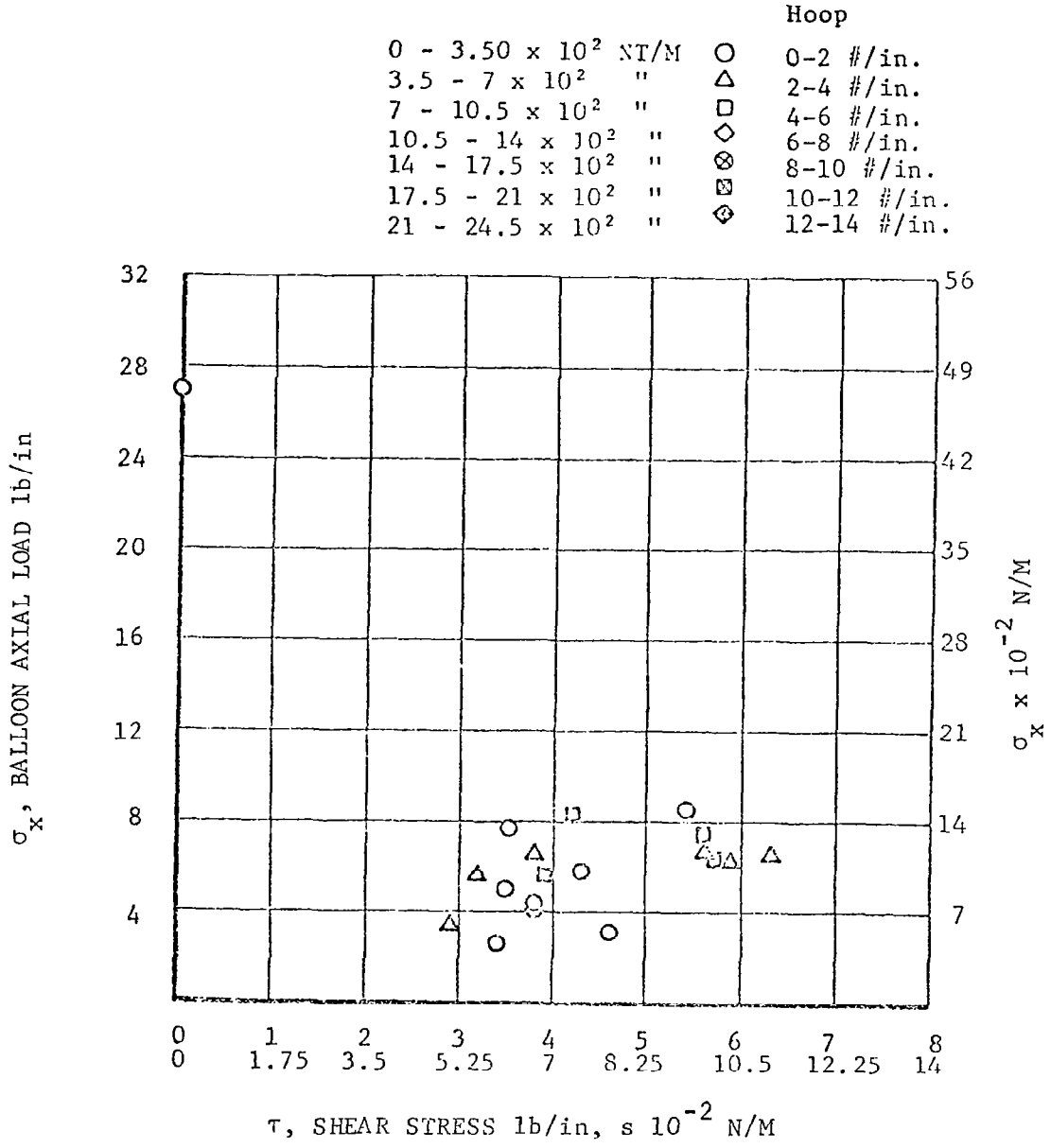

FIGURE 14 45° FTL MATERIAL ROLLER COATED YARNS

MD TD
1000 x 440 denier yarns

		Hoop	
0 - 3.50 x 10 ² NT/M	○	0-2 #/in.	
3.5 - 7 x 10 ² "	△	2-4 #/in.	
7 - 10.5 x 10 ² "	□	4-6 #/in.	
10.5 - 14 x 10 ² "	◇	6-8 #/in.	
14 - 17.5 x 10 ² "	⊗	8-10 #/in.	
17.5 - 21 x 10 ² "	⊠	10-12 #/in.	
21 - 24.5 x 10 ² "	⊡	12-14 #/in.	

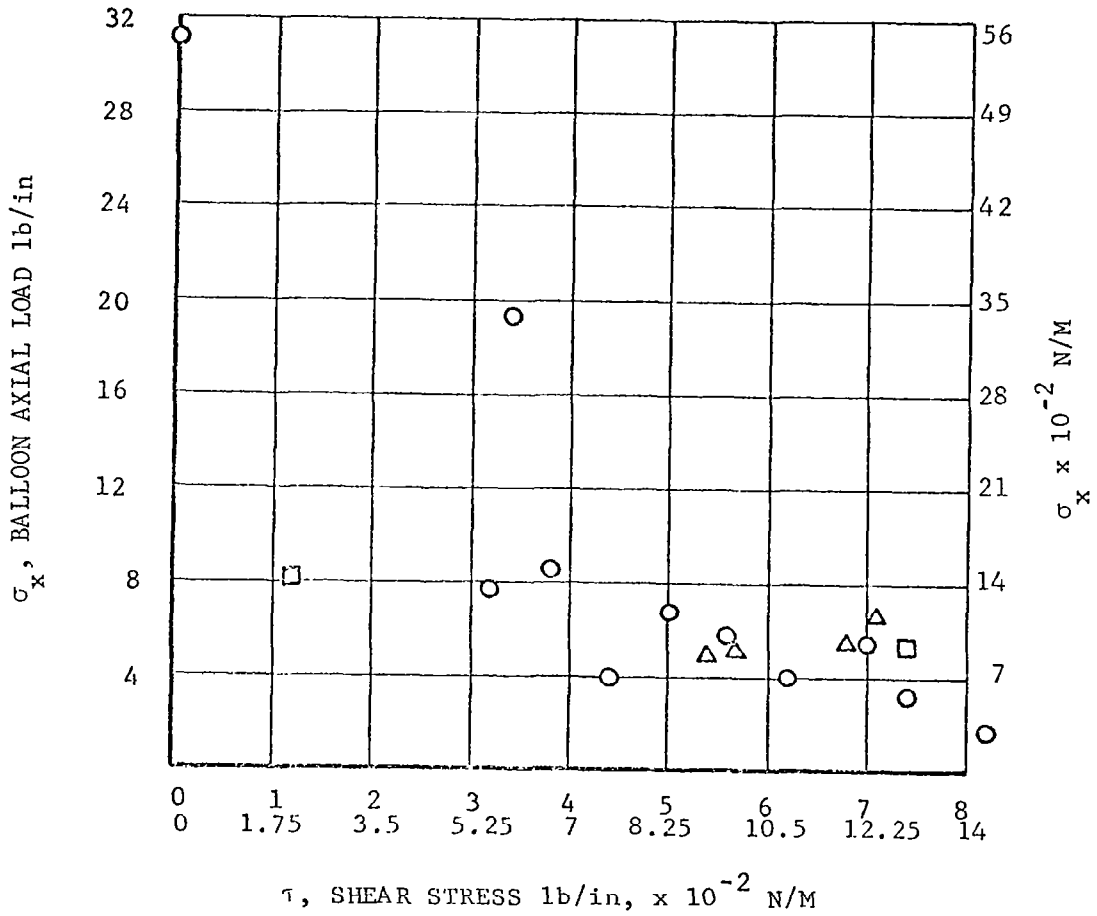

FIGURE 15 60° FTL MATERIAL - ROLLER COATED YARNS

MD TD
1000 x 440 denier yarns

Hoop	
○	0-2 #/in 0 - 3.50 x 10 ² NT/M
△	2-4 #/in 3.5 - 7 x 10 ² "
□	4-6 #/in 7 - 10.5 x 10 ² "
◇	6-8 #/in 10.5 - 14 x 10 ² "
⊗	8-10 #/in 14 - 17.5 x 10 ² "
⊠	10-12 #/in 17.5 - 21 x 10 ² "
◊	12-14 #/in 21 - 24.5 x 10 ² "

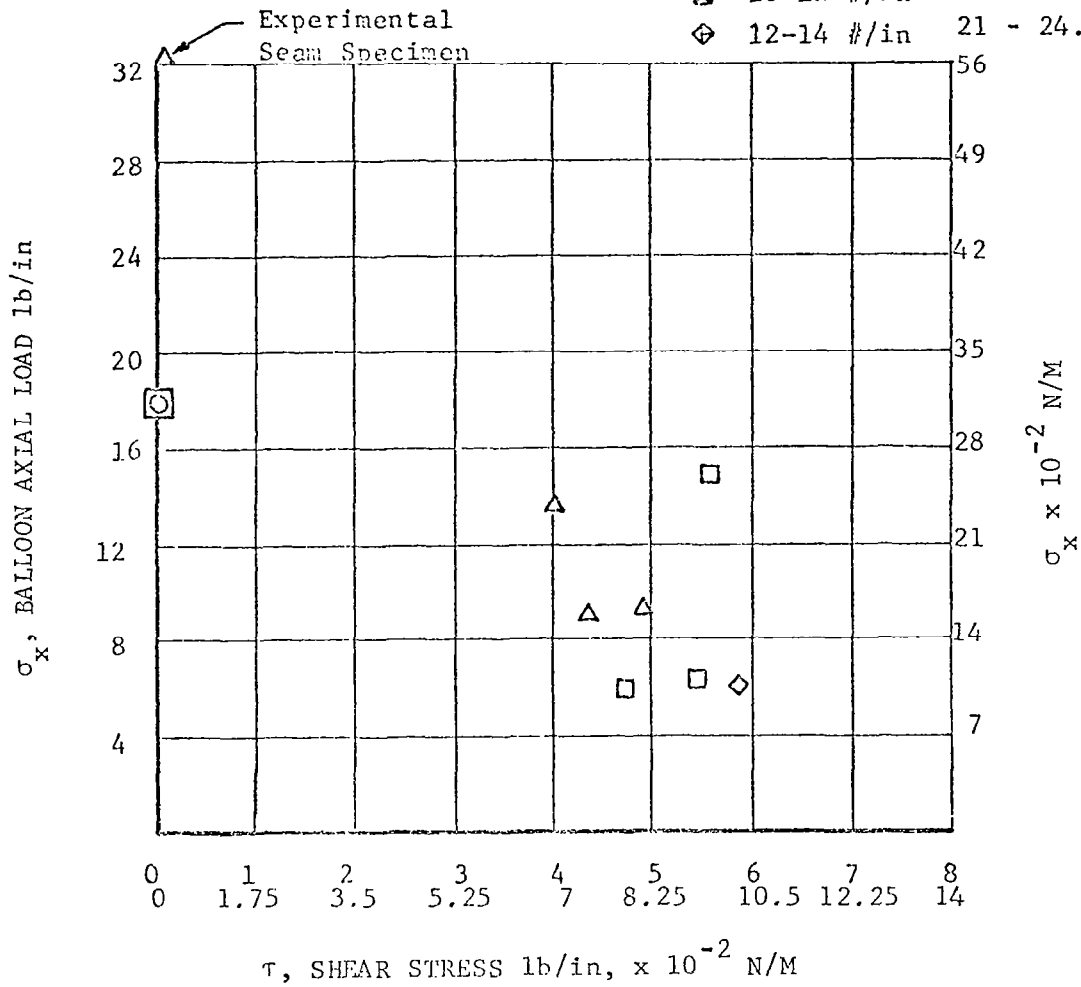

FIGURE 16 60° FTL MATERIAL PRECOATED MYLAR

MD TD
1440 x 440 denier yarns

Hoop

0 - 3.50 x 10 ² NT/M	○	0-2 #/in.
3.5 - 7 x 10 ² "	△	2-4 #/in.
7 - 10.5 x 10 ² "	□	4-6 #/in.
10.5 - 14 x 10 ² "	◇	6-8 #/in.
14 - 17.5 x 10 ² "	⊗	8-10 #/in.
17.5 - 21 x 10 ² "	⊠	10-12 #/in.
21 - 24.5 x 10 ² "	◊	12-14 #/in.

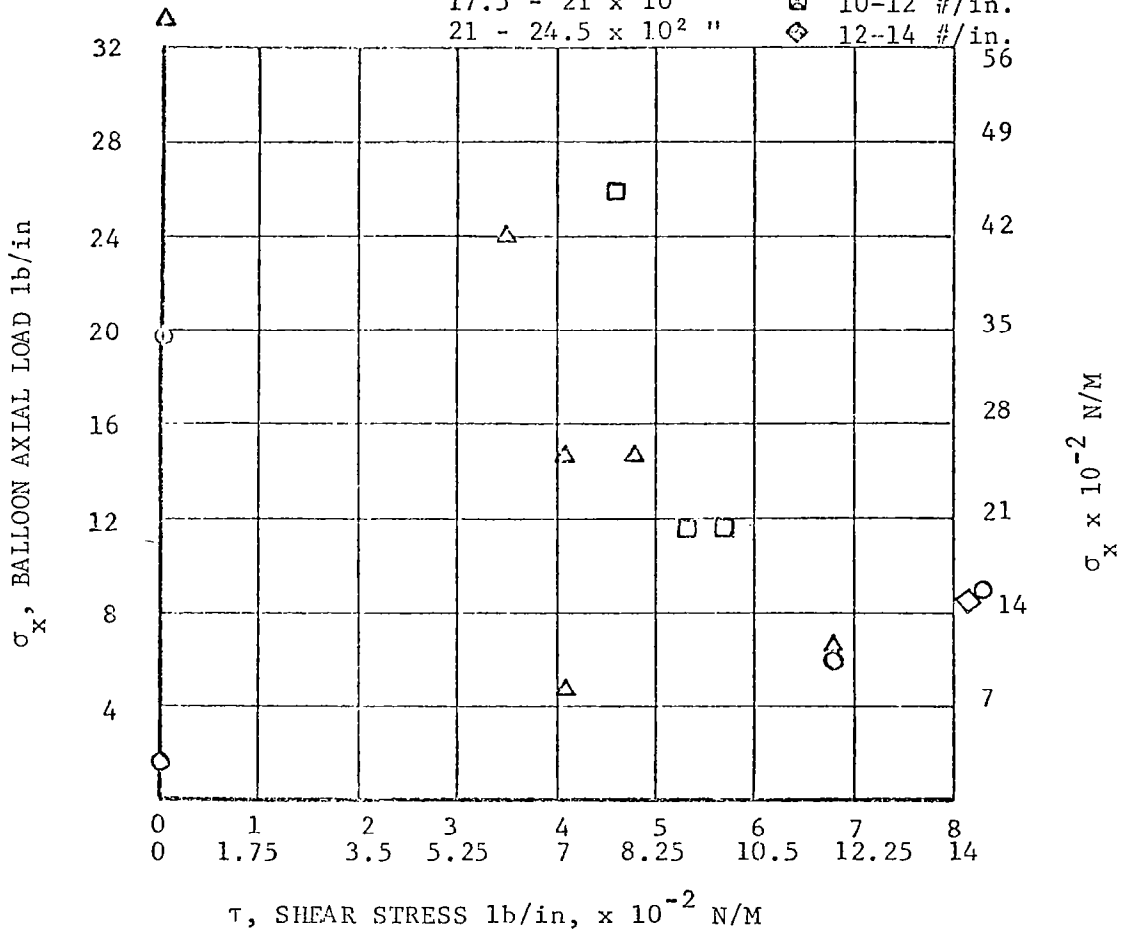

FIGURE 17 60° FTL MATERIAL - PRECOATED MYLAR
POST COATED LAMINATE

HOOP

0-3.5 x 10 ² NT/M	◇	0-2 #/in.
3.5 - 7 x 10 ² "	○	2-4 #/in.
9.45 x 10 ² "	△	5.4 #/in.
7.16 x 10 ² "	◇	4.1 #/in.
11.0 x 10 ² "	□	6.3 #/in.

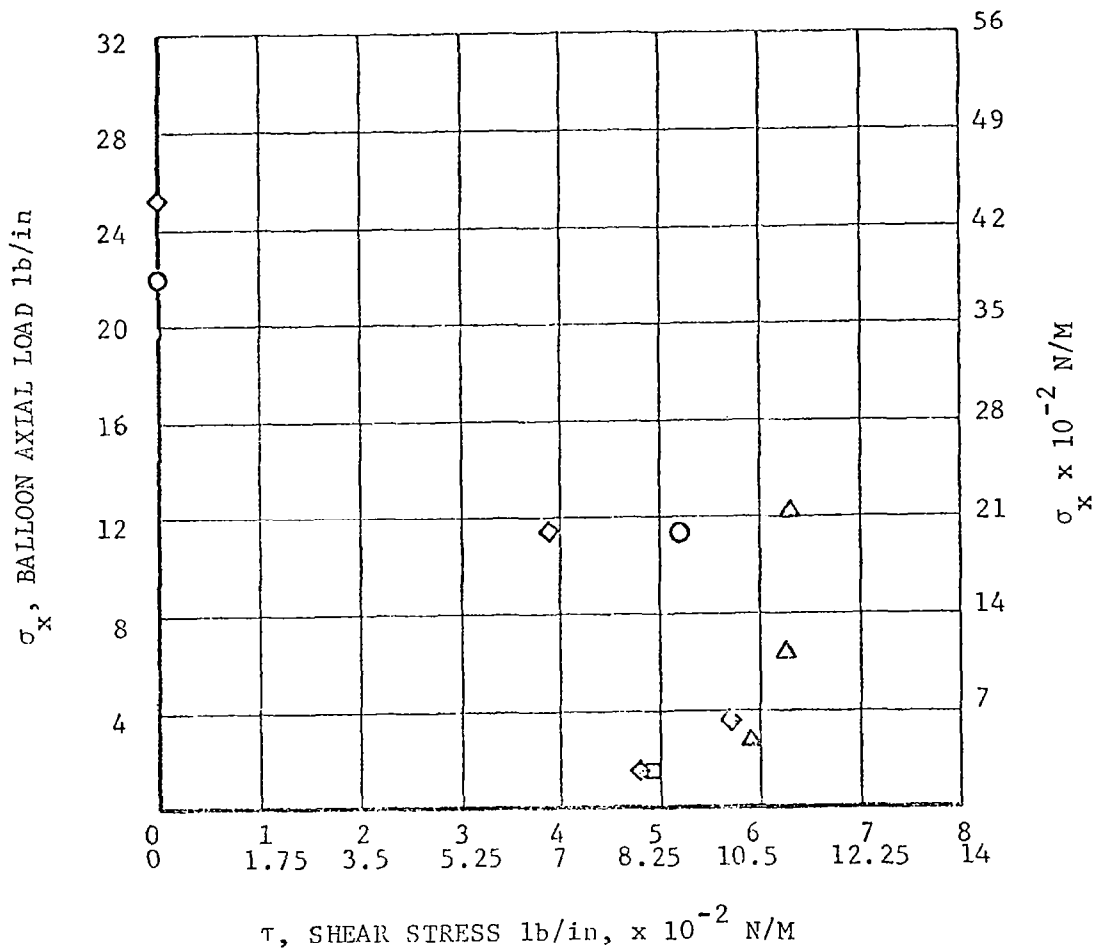

FIGURE 18 60° FTL G127600

PREPRODUCTION RUN

HOOP

0 - 3.5 x 10 ² NT/M	○	0-2 #/in.
3.5 - 7 x 10 ² "	△	2-4 #/in.
7 - 10.5 x 10 ² "	□	4-6 #/in.
10.5 - 14 x 10 ² "	◇	6-8 #/in.
14 - 17.5 x 10 ² "	⊗	8-10 #/in.
17.5 - 21 x 10 ² "	⊠	10-12 #/in.
21 - 24.5 x 10 ² "	⊡	12-14 #/in.

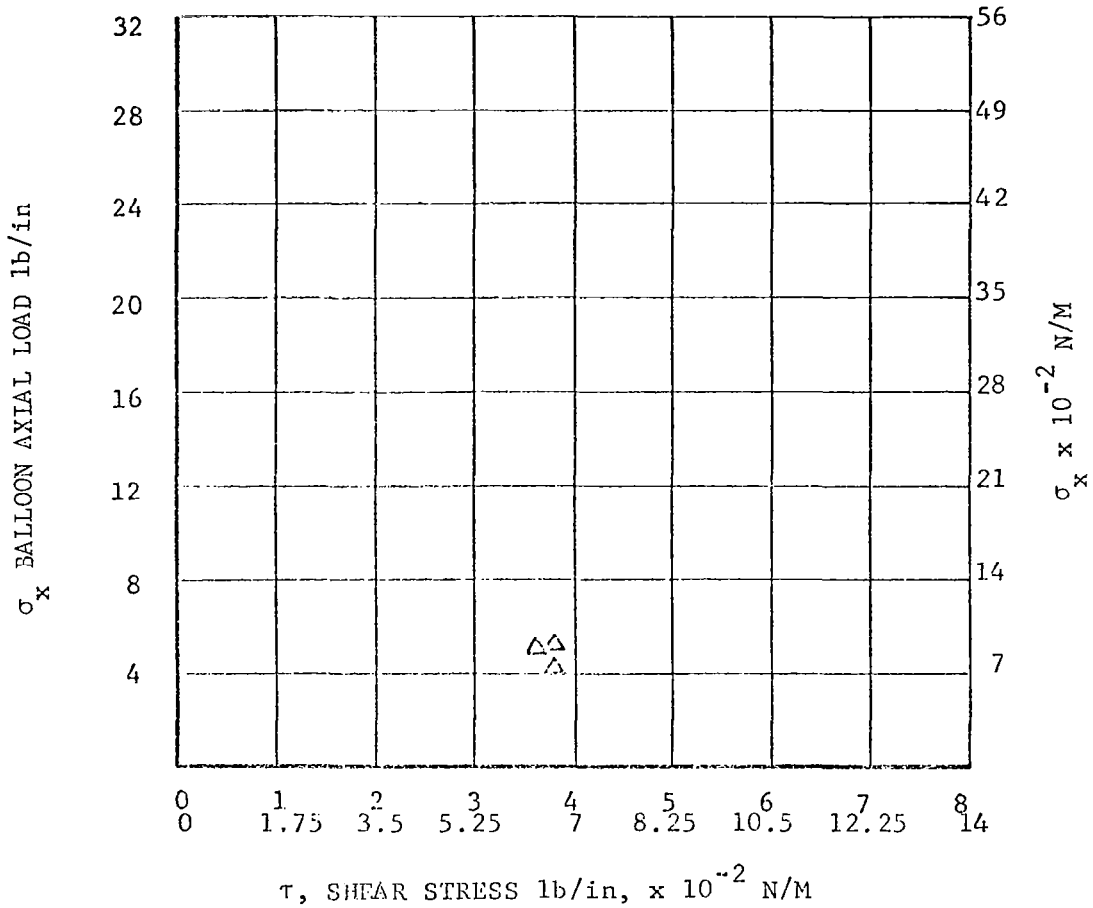

FIGURE 19 0.35 MIL HIGH ELONGATION MYLAR

60° FTL materials, is far better when the material is loaded biaxially than the test standard, leno weave laminate. This was true of all candidate materials independent of their strength to weight ratio. The FTL materials have a higher strength to weight value than the scrim reinforced material.

The 45° FTL material data does not show performance as good as the 60° material. However, this may be due to the variations in TD yarn spacing rather than the angle. The rather larger "windows" in the 45° material deform to a visually obvious extent when the internal pressure level is raised. The film in the 45° test specimens consistently failed at about half the internal pressure of the 60° materials. Since the high differential film pressures necessary to simulate the tensile loading in the test are not actually encountered in a balloon flight, it is doubtful whether this observed characteristic is of much significance in a real balloon. Time and funding limitations prevented further pursuit of this point.

As mentioned earlier, there were two distinct methods of adhesive application tested in the 60° FTL group. The first was a coated yarn material similar to the "45°" and "82°" materials. The second laminate was made using Mylar precoated with adhesive and a dry yarn array. Since the yarns were not twisted when laminated, it was necessary to recoat this material with adhesive to tie down the dry yarn filaments. If this was not done, loose filaments of the dry yarn during handling would be pulled off and broken thus degrading the strength. A comparison between the coated Mylar laminate and the coated yarn laminate of the same 60° geometry is shown in Figures 13 and 14.

The geometric regularity of the yarn array is much closer to the ideal when the Mylar is precoated and the yarn laminated dry than when the yarns are coated during lamination because the pattern is disturbed due to an adhesive build-up in the downstream portion of the carrier system after the yarns are coated. This probably explains the slight improvement of the coated Mylar laminate over the coated yarn laminate in the results.

Uniaxial tests. — Results of the one dimensional coupon tests are presented in Table 3. Tensile values (T) are given in N/M (lb/in) and elongation (E) in percent. Data are presented for machine direction (MD), transverse direction (TD) and at 45° right and left of the MD axis, except for machine (FTL) made 60° laminates where values are at 60° right and left.

Tensile values in TD for the rectangular scrim materials (GT-11) and the nearly rectangular, 82° FTL materials (GT-111-4) are noticeably higher than for the other FTL materials since the transverse yarns lie in or near the test direction. TD values for other FTL candidates are not meaningful since no yarns in the 45° and 60° materials lie between jaws so the Mylar must support the full load. Except for the 45° FTL material a similar situation exists for the tensile tests made at 45°.

TABLE 3: UNIAXIAL TENSILE TEST RESULTS

Each value is the average of 10, 1 inch wide specimens tested per ASTM Method D882.

T1 - Section tensile strength (kg/m) E - Elongation (%) (b) - Adhesive applied to yarn
 TB - Section tensile strength (lbs/inch) (a) - Adhesive applied to film (c) - Diagonal tests run @ 6 along T.D. yarns

Description of Material	Temp. °F	MD			TD			45°L			4
		TB	T1	E	TB	T1	E	TB	T1	E	
Isotropic Mylar Film	70	8	128.8	175	8	128.8	132	8	128.8	129	8
	-90	10	161.0	66	11	177.1	48	10	161.0	44	10
G001100 (a)	70	41	660.1	18	30	483.0	21	13	209.3	47	12
	-90	44	708.4	12	31	499.1	11	14	225.4	12	14
G011104 Machine Layed (b)	70	62	998.2	17	19	305.9	13	8	128.8	28	7
	-90	46	740.6	15	14	225.4	5	8	128.8	7	10
G011104 Hand Layed (b)	70	61	982.1	19	23	370.3	12	6	96.6	25	6
	-90	55	885.5	13	17	273.7	5	8	128.8	4	7
60° T.D. Hand Layed (b)	70	42	676.2	18	7	112.7	25	8	128.8	24	8
	-90	47	756.7	16	9	144.9	5	10	161.0	5	10
45° T.D. Hand Layed (b)	70	42	676.2	18	6	96.6	29	17	273.7	17	17
	-90	46	740.6	16	9	144.9	5	17	273.7	8	16
60° T.D. Machine Layed (b)	70	42.1	677.8	20.5	—	—	—	19.9	320.4	21.9	—
	-90	39.0	627.9	14.7	—	—	—	21.5	346.1	12.8	—
45° T.D. Machine Layed (b)	70	42.9	690.7	19.9	—	—	—	20.8	334.9	21.6	—
	-90	39.3	632.7	13.2	—	—	—	20.4	328.4	10.1	—
60° T.D. (1000 d M.D.) Machine Layed (a)	70	41.5	668.1	19.9	—	—	—	20.9	336.5	19.9	—
	-90	32.8	528.1	11.3	—	—	—	23.1	371.9	14.1	—
60° T.D. (1440 d M.D.) Machine Layed (a)	70	56.4	903.0	19.5	—	—	—	19.8	318.8	20.7	—
	-90	39.7	639.2	8.7	—	—	—	18.9	304.3	7.3	—
G 127600 (a)	70	53.7	864.6	17.8	—	—	—	21	338.1	20	—
	-90	67	1078.7	17	—	—	—	24.3	391.2	16	—

It is significant that tensile values increase and elongation decreases when the test temperature is lowered from room temperature to '68°C (-90°F).

5.0 CONCLUSIONS

1. Testing of thin film materials in cylinder form as opposed to two-dimensional coupon tests yields more complete information on material properties.
2. The shear capability of a balloon material can be increased by changing the angle of the transverse yarn from perpendicular to the web or machine direction to some angle between 60° and 45° to the web direction.
3. Results of these cylinder tests indicate that the 60° material is superior to other FTL type candidates examined. However, as pointed out earlier, the test results may be influenced by the yarn spacing due to pressure effects inherent in the test method, but not in the balloon service environment.
4. The greater the denier of the MD yarn, the greater the ability of these materials to take shear loads.
5. The adhesive component has the least ability to withstand high loads at low temperatures. As temperature is reduced, the adhesive becomes brittle sooner than the Mylar and the yarn. Stress concentrations produced by fractured adhesive result in local film failure at material stress levels which are small compared to the ultimate. The amount of adhesive and its method of application are factors that should be studied in further efforts directed at achieving more optimum materials. Other adhesives compatible with this type of laminate that might exhibit better properties at cold temperatures should also be investigated.

APPENDIX A

MODIFICATIONS TO
THE G. T. SCHJELDAHL CO.
FLYING THREAD LOOM

APPENDIX A

1.0 INTRODUCTION

Certain modifications were made to the Flying Thread Loom (FTL) to achieve yarn patterns as regular as those generated in handmade layups for the material test program. Modifications were made to the carrier system and the drum providing the transverse yarn geometry.

The carrier system consists of the cables which move the formed yarn matrix along the system and into the combining section, the plate on which these cables ride, the spreader bars which assist in maintaining the geometry, and the cable pulleys.

The drum system consists of a cylindrical shell, drive system to rotate the shell, the canisters for the yarn packages and the system to control yarn tension. The changes made to the drum and the carrier system are described below with the reason for each change. Photographs of the final system are shown in Figures 20 through 23.

2.0 DRUM SYSTEM MODIFICATIONS

2.1 Drum Relocation

In its previous state the distance between the rotating drum and the combining section of the laminator limited the lowest TD yarn angle to 62° . Since some of the candidate materials require transverse yarn angles as low as 45° , it was necessary to move the drum away from the combining section by about 61 cm (2') to allow the yarns to lay down on the plane of the carrier system prior to entering the combining section of the laminator.

2.2 Drum Speed Reduction

The rotational speed of the drum relative to the longitudinal machine speed controls the angle of the transverse yarn. The minimum speed of the unmodified drum would have required excessive machine direction speeds to attain the low TD yarn angles approaching 45° . Since this would be impractical for the laminating operation the machinery was modified by the addition of a different drive unit to reduce the minimum drum speed to 1 rpm. As an additional improvement the reduction in the drum speed reduced the speed at which yarn was dispensed through the tension system and reduced the frequency of yarn breakage.

2.3 Drum Edge Reinforcement and Yarn Deployment

Consistency of the transverse yarn pattern is dependent on the spacing and rigidity of the yarn guides around the rim of the drum. The unmodified

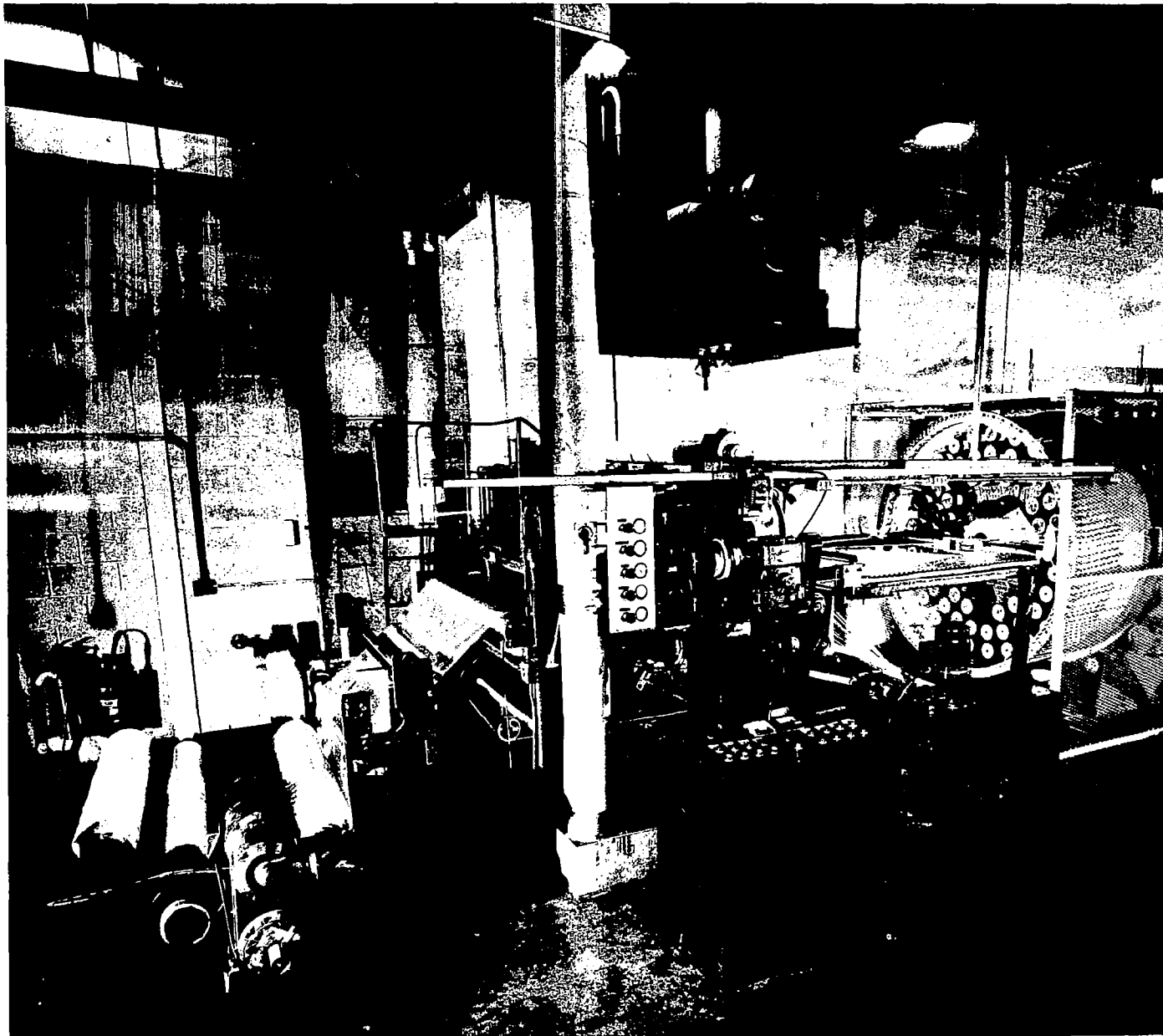

FIGURE 20, FLYING THREAD LOOM LAMINATOR

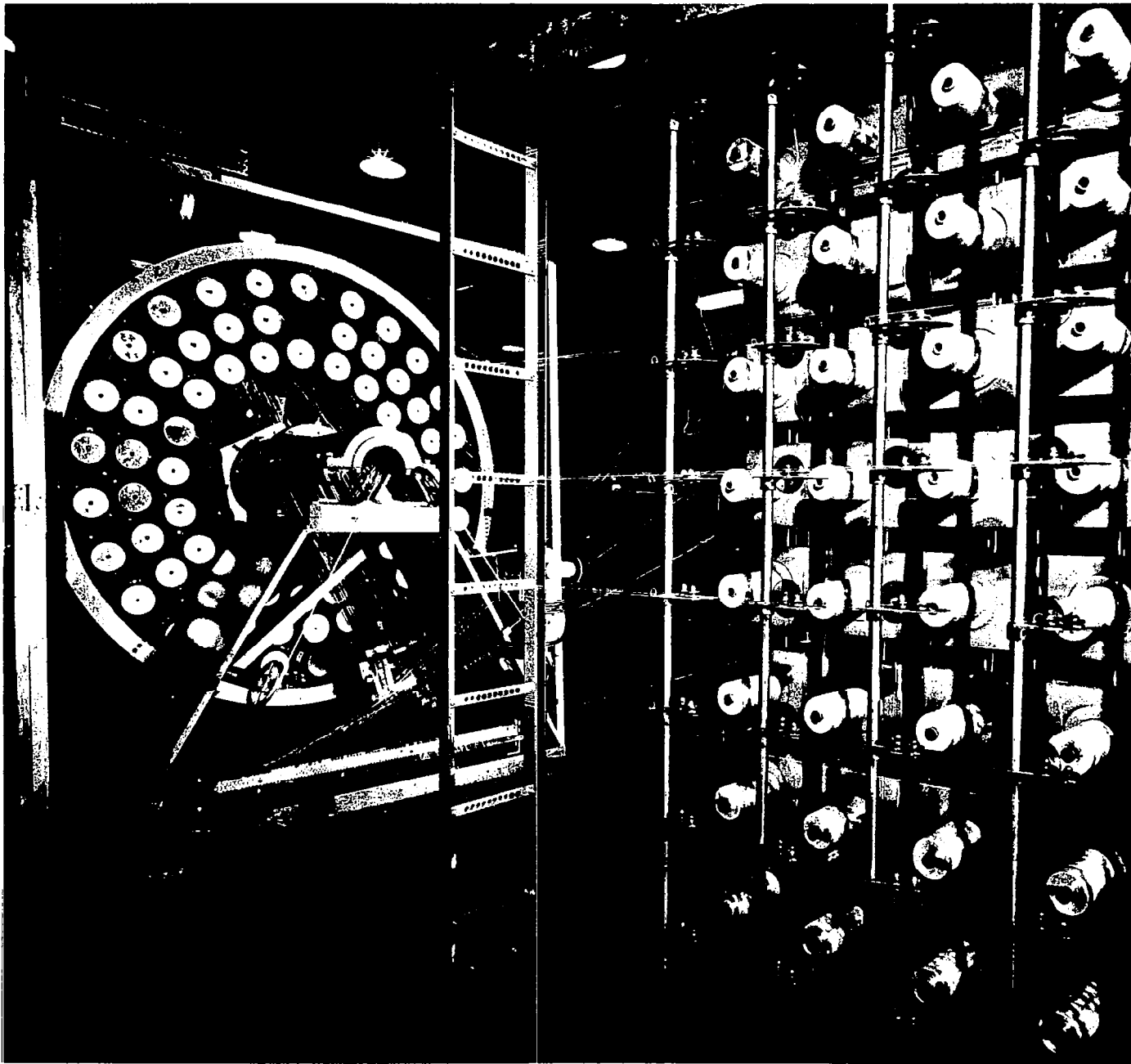

FIGURE 21, YARN DISPENSING DRUM AND CREEL SYS

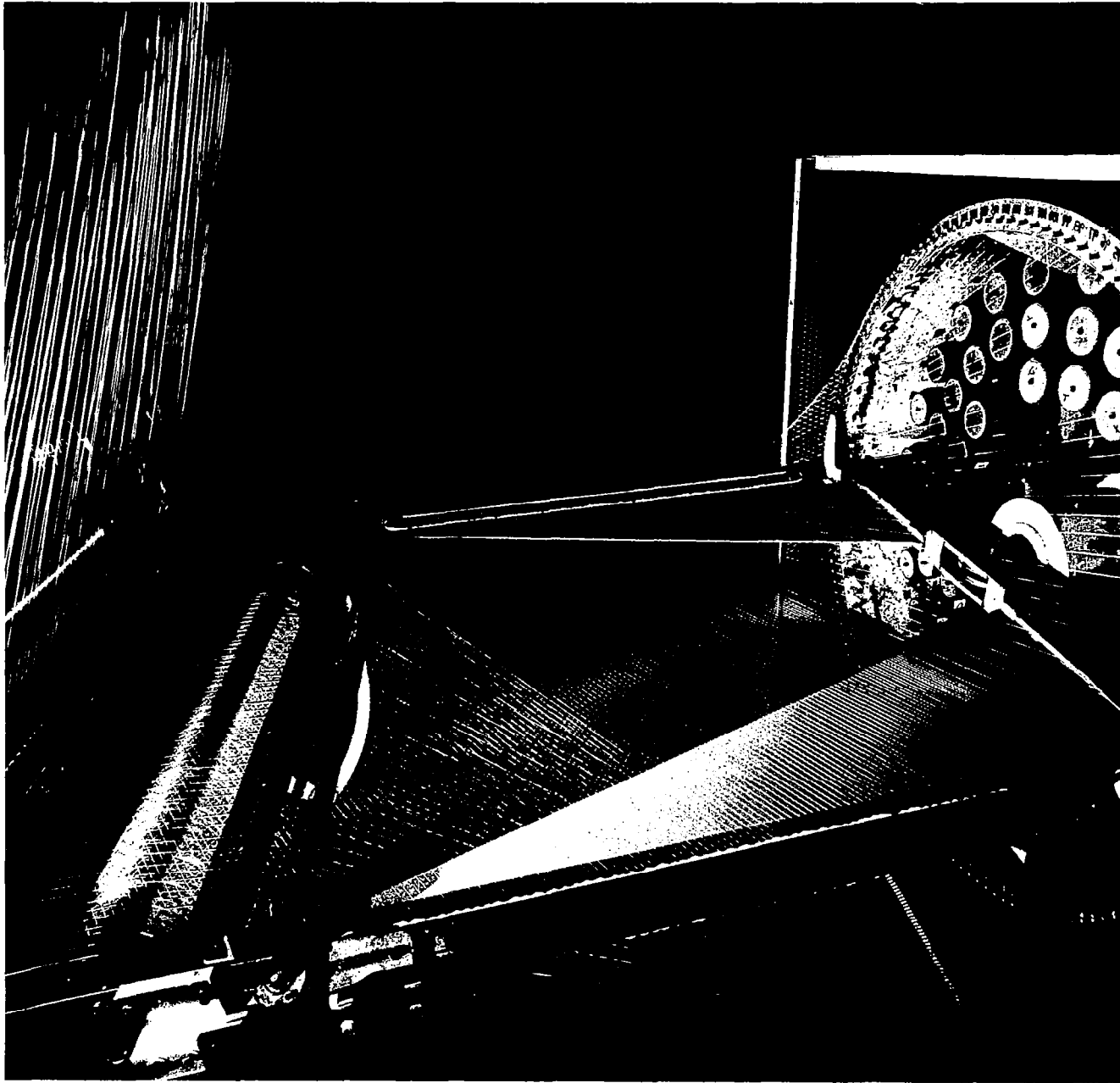

FIGURE 22, YARN MATRIX AND CARRIER SYSTEM

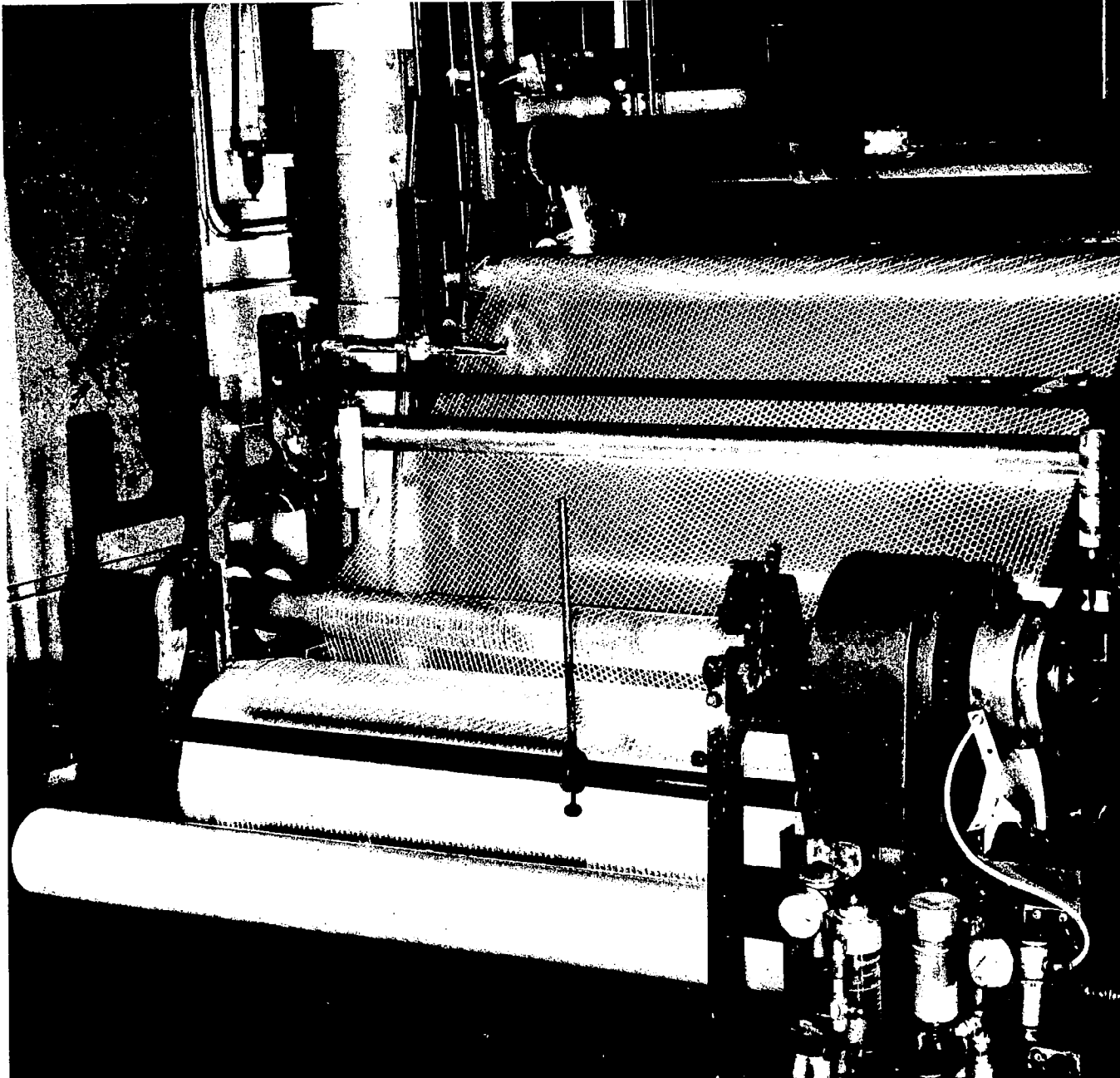

FIGURE 23, FINISHED LAMINATE

APPENDIX A

drum was merely a sheet metal cylinder which allowed some deformation in guide position due to variation in yarn tension. This edge was made rigid by adding a metal ring around the rim of the drum concentric with the hub. This stiffener ring is an aluminum piece 203 cm (80") in diameter with a cross section of 2.54 cm x 7.62 cm (1" x 3"). Metal tubes with ceramic bushings at their ends were equally spaced in this ring to serve as the final guide to control yarn spacing. It was necessary to rebalance the rotating assembly within 5472.7 N/M (500 oz/in) to minimize the loading on the bearings.

The yarn package originally used on the rotating drum was a "cheese" configuration, of straight cylindrical form. This configuration was discarded in favor of a cone shaped spool to afford more uniform take-off tension. To assist in dispensing the yarn, the position of the spools was changed from the web of the drum to the outer shell. Each spool was fitted with a cover and a thread guide tube through which the yarn was carried to the outer surface to the disc and post tension devices.

2.4 Increased Transverse Yarn Capacity

As the drum originally existed, there was a capacity of 82 spools for dispensing transverse yarn. To achieve the desired yarn density at the TD yarn angles employed in the candidate materials, it was necessary to increase the drum yarn capacity to 140 spools.

3.0 CARRIER SYSTEM AND YARN POSITIONING MODIFICATION AND IMPROVEMENTS

3.1 Carrier Changes

Due to drum repositioning, the carrier system length was increased approximately 61 cm (2'). The carrier cable tensioning system was improved by the addition of two, coupled cable sheaves mounted in series with each other. The cable drive was changed by driving directly from the power source in the laminator rather than through the draw rolls.

3.2 Machine Direction Yarn Positioning

Originally, all of the machine direction yarns were introduced into the laminator below all of the transverse yarns. Modification was made to insert one-half of the machine direction yarns under the transverse yarns and the other half over the transverse yarns so that adjacent MD yarns in the finished laminate are alternately above and below the TD yarns. To accomplish this, two independent yarn combs were installed so that they can be aligned independent of one another to achieve the desired spacing and can be moved together to position the machine direction matrix in a desired position relative to the transverse direction yarn array. This allows the longitudinal yarns to be aligned with the intersection of the transverse yarns forming a consistent pattern of triangles.

APPENDIX A

3.3 Transverse Direction Yarn Positioning

The transverse yarn array is carried through the machine on moving cables positioned at the edges of the carrier plate. While being dispensed from the drum, the yarn is wound around the cables, the relative angle of the yarn with respect to the cable changes and there is a tendency for yarn slippage along the cables for loss of spacing control. To minimize this, a pair of endless rubber grooved belts was installed which move with the cable system while pressing against the cable and effectively preventing yarn slippage. The belts extend from the lay down point to the combining section of the laminator.

3.4 Adhesive Drying System

In the original facility the roller coated yarns were partially dried by warm air being blown across the yarn matrix, removing the excess solvent prior to entering the combining section. It was felt that improvement of the flow pattern across the drying system could eliminate changes in yarn position due to the air turbulence caused by the drying system; therefore, a honeycomb grid was installed on the upstream side to straighten the flow.

This was not used in the final process equipment since the yarn coating process was eliminated except for the lower machine direction yarns. Since little adhesive was applied to these yarns, no forced drying was necessary.

Final modifications performed to the equipment to achieve the selected configuration of material were as follows:

- . The machine direction combs were placed close to the combining system to increase the MD yarn position control.

- . The dryer system was removed.

- . The carrier cable splicing was analyzed and the original method discarded for an improved splicing technique, developed by personnel of Langley Research Center.

- . The carrier system was stabilized by adding an additional compression bar just upstream of the combining section, to reduce deformation in this previously unsupported portion of the carrier system.

- . The friction belts utilized to hold the transverse direction yarns in place were further modified for better yarn control by the addition of a rubber coating having a non-skid surface.

APPENDIX B

DRAWINGS AND
BILL OF MATERIALS FOR
CYLINDER TEST APPARATUS

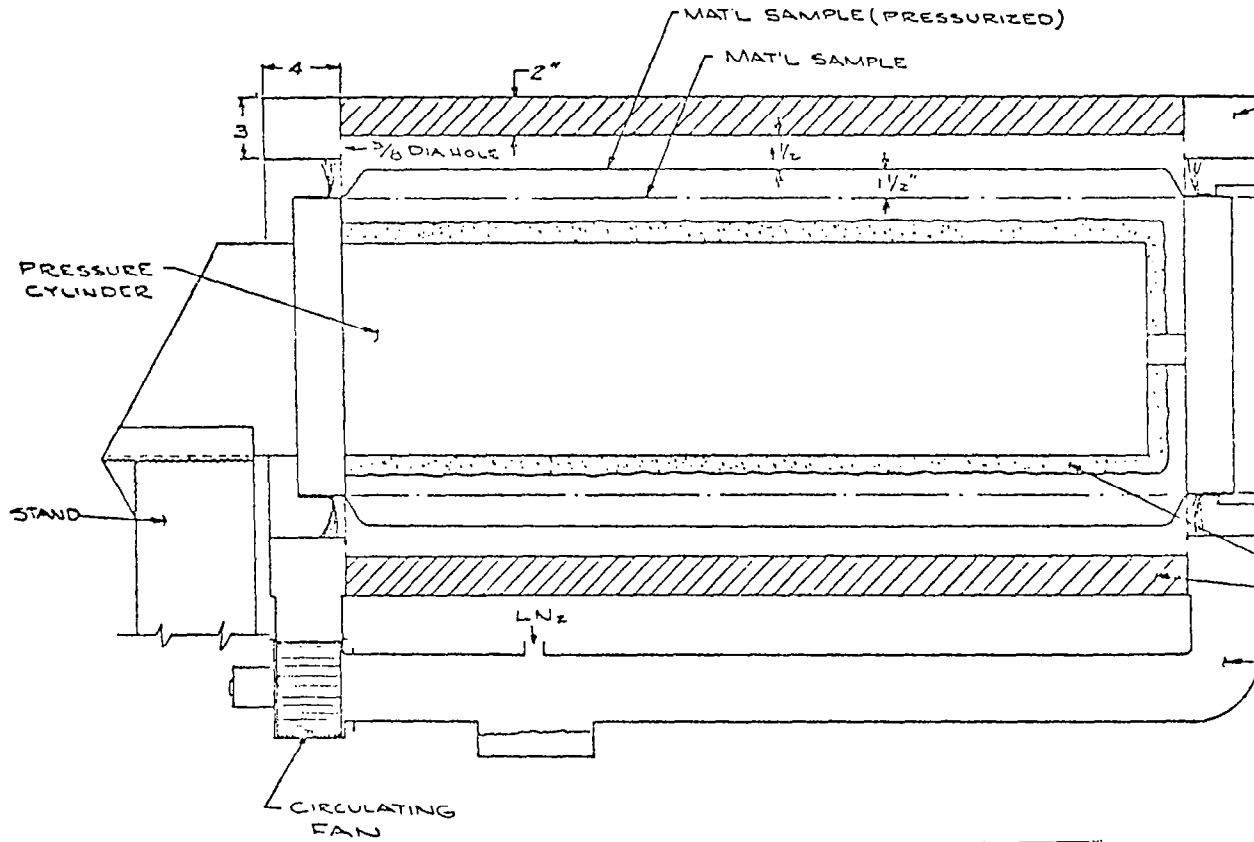
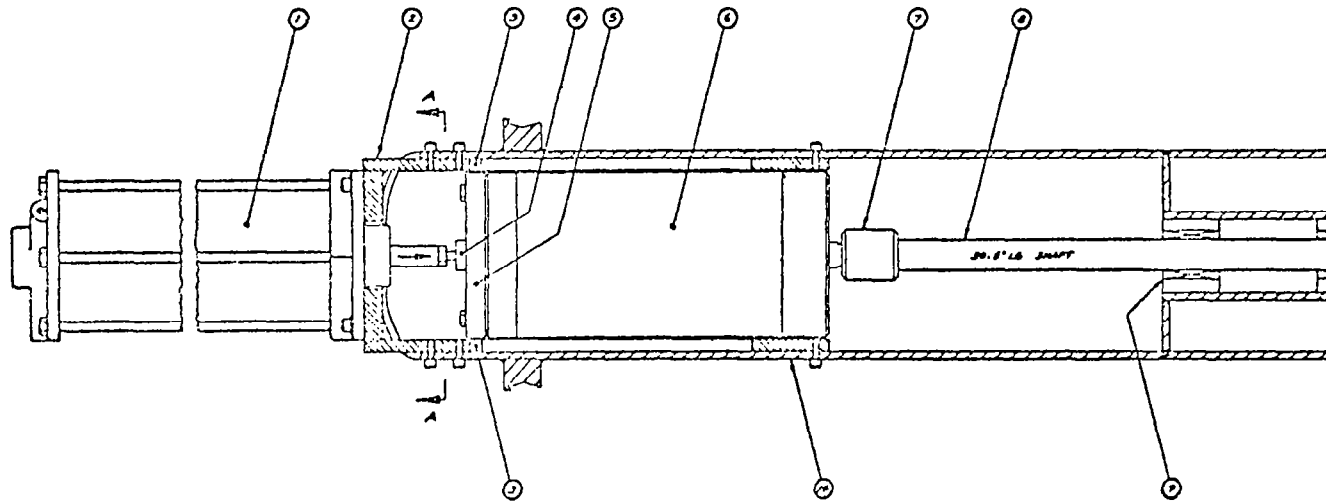
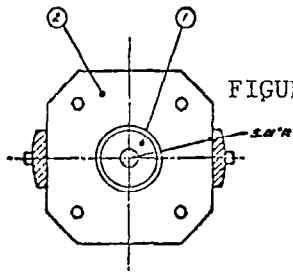

FIGURE 24:

DRAWING TITLE			
CYLINDRICAL TEST FIXTURE MODIF. TO -90°F			
SIZE	CODE IDENT NO.	DRAWING NO.	REV.
C	07955	SD #1307	



VIEWED FROM TOP
CW ALONG CENTER LINE



SECTION A-A
DRAWN BY CW

FIGURE 25 BIAKAL TEST FACILITY

REVISIONS	
NO.	DATE
1	07/23 30" CW

1	SD #208
1	
1	SD #408
1	
1	
1	
1	
2	A25R43
1	
1	BRNA - 200"
1	
1	625
2	CES - 10
1	
1	Max 2 5' 0" 3M
1	
1	Page 00000

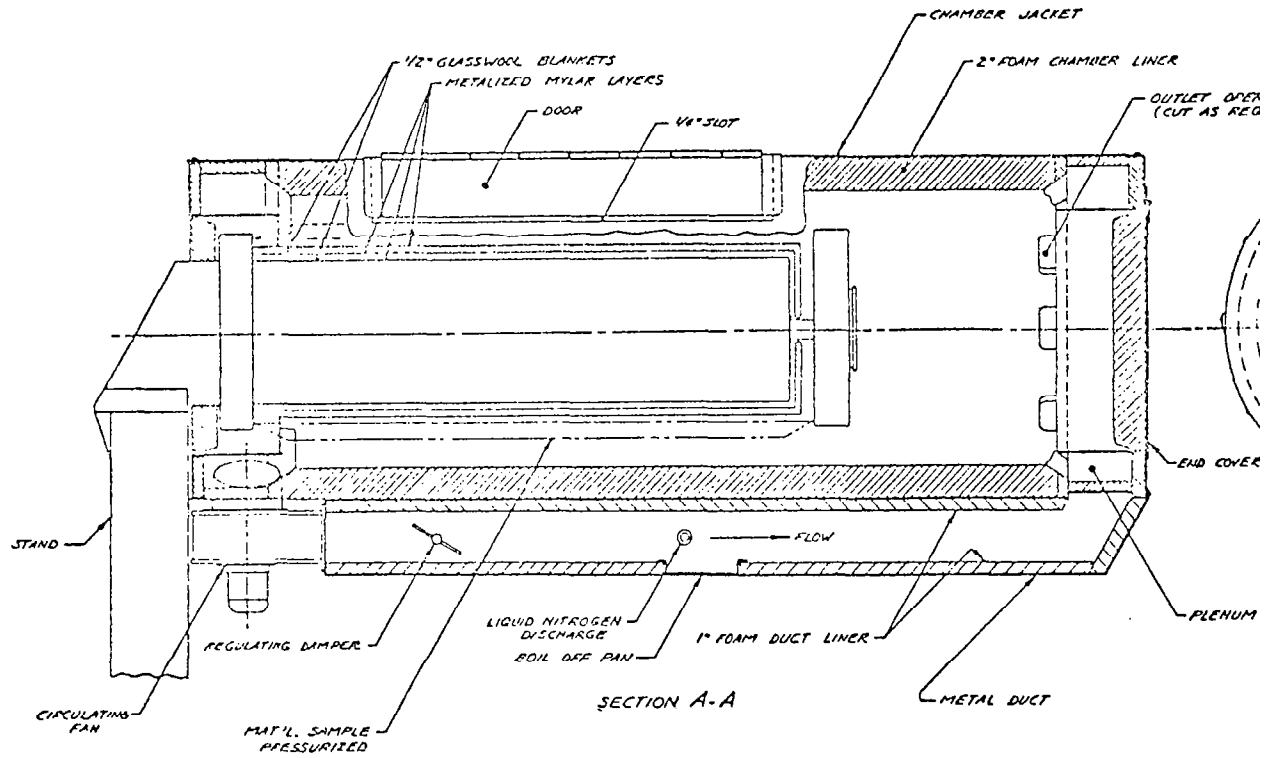

FIGURE 26

DRAWING TITLE			
COOL CHAMBER - CYLINDER TEST			
SIZE	CLASS. REVISION NO.	DRAWING NO.	REV.
D	07955	5D # 1248	

APPENDIX B
BILL OF MATERIALS

Cold Box

3 Helipots - SA3216

Wheelco Temperature Controller - 100^o cent.

Honeywell Brown Electronick 15 temp. recorder

2 Power Supplies

Honeywell 906 C Visicorder

Dry Nitrogen + Regulator

Air Supply - 100 psi

1 Magnehelic Gage 50 in. H₂O (for internal pressure)

2 Gages 0 - 160 psi (for axial and torque) Model No. 5803

1 Gage 0-15 psi (internal pressure) Model No. 5803

2 Transducers - Statham 0 - 150 psi

1 Transducer - Statham 0 - 10 psi

Calibration Box for Helipots

Calibration Box for Transducers

1 Nopak Cylinder 5" dia. x 15" travel, Model No. D Class 1

Liquid Nitrogen Supply Elec. Valve (Valcor 90C-89C-7A)

Carter Torque Actuator 280^o 8 RHA

Thermocouple Wire - 24 ga, Type T

Chart Paper for Electronik 15 No. 5240 -100^o to +100^o

Dayton Shade Pole Blower 2C841

Casters 95-4150-RC-0B

Visicorder Paper 16774562-615 Linagraph direct

Print Paper Type 1855

APPENDIX B

BILL OF MATERIALS Continued

Tom Thumb Self-Aligning Piston Rod Coupling, male end

5/8" - 18 threads female end 1/4" 20 threads No. 625

Manual 4-way Valve 9002MC

Braided Stainless Steel Flex Hose, Model No. 37-1014-1

1/4" Npt. Extended Stem Goddard Valve 17-1013-2

Torrington Cam Followers CRS10

Thompson Ball Bushings, 1 1/2" ID A243848

Thompson Stainless Steel Shaft 1 1/2" dia., 30 1/2" long

60 Case Hardened Material 440C

APPENDIX C

MULTI-AXIAL TENSILE TEST SPECIFICATION

APPENDIX C

1.0 SCOPE

This procedure outlines a method for measuring multiaxial tensile properties of non-porous films and laminates by means of torque, axial load and internal pressure applied to a cylindrical test specimen.

2.0 APPLICABLE DOCUMENTS

The following documents form a part of this procedure: Q000303 - Gore Seams, Requirements For.

3.0 APPARATUS

3.1 Device to apply internal pressure, axial load and torque to cylindrical specimen. —

3.2 Cold Chamber with temperature regulator and LN₂ control valve. —

3.3 Compressed Air Supply - (at least 80 psig line pressure). —

3.4 Pressurized Dry Nitrogen gas supply with regulator. —

3.5 Eight channel recording oscillograph with associated pressure and displacement transducers, amplifiers, and power supply. —

3.6 Liquid Nitrogen Supply. —

4.0 PREPARATION OF TEST SPECIMEN

4.1 Inspection. — Carefully inspect material to be tested for holes, foldovers and wrinkles which might cause local failure of the gas barrier under pressure. Repair any damage in accord with applicable procedures and specifications for the material or replace sample.

4.2 Cutting. — For each test specimen, cut two pieces of material each 22.0" \pm 0.05" by 50" \pm 0.5" using a new razor blade on a firm cutting surface such as cork, chip board, blotting paper or masonite.

4.3 Sealing. — Form the pieces into a tube of 44" circumference by forming two 50-inch butt joints connected with appropriate thermoplastic primary and bi-tapes in accord with GTS Specification Q000303. Allow seams to age for at least 24 hours before testing.

APPENDIX C

4.4 Tab Attachment. — Heat bond two tabs of 1-inch wide T3A0003 tape to the specimen each 6 inches from one seam. One tab shall be 18.5 inches from one end of the cylinder and the other shall be 30.5 inches from the same end.

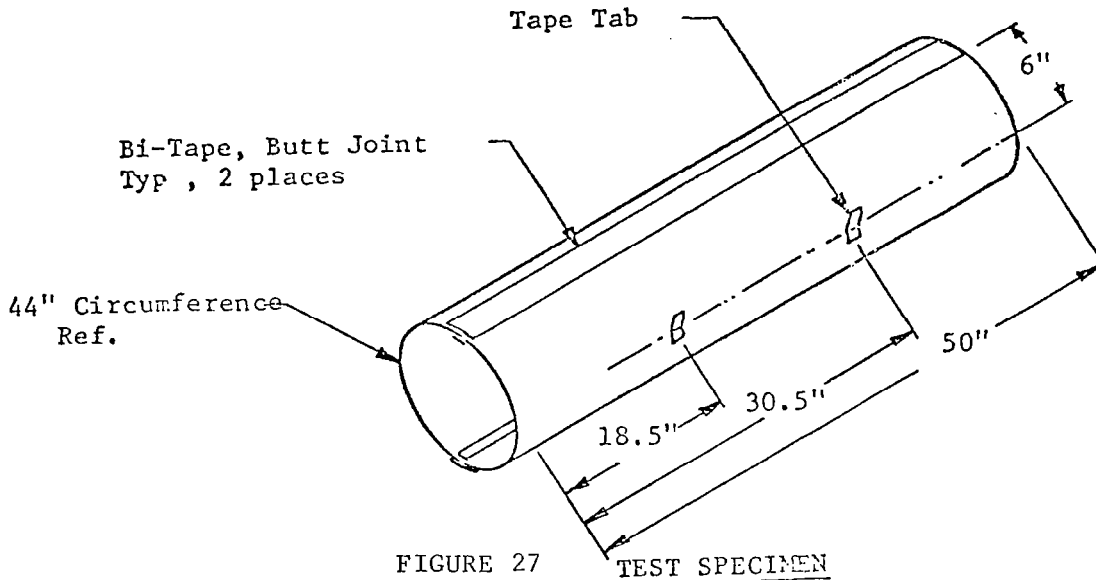

FIGURE 27

5.0 CALIBRATION

5.1 Torque Load Calibration

5.1.1 Set up. — Place wrench socket and bar over nut on axis of moveable end plate of the test apparatus. Attach a spring scale (range: 0-100 lbs) to the bar one foot from the axis of rotation. Secure scale to a fixed support. Attach torque air cylinder and torque air pressure transducer to compressed air supply. Attach recorder to transducer.

5.1.2 Load application. — Start recorder and apply air pressure with torque air regulator in increasing pressure increments. At each pressure valve, record the torque on the spring scale (ft. - lbs). Plot pressure versus torque to obtain a calibration curve.

5.2 Axial Load Calibration

5.2.1 Set up. — Mount Dillon load cell (1000 lb. capacity) between ram of tested and fixed support. Set zero point on load cell readout instrument.

APPENDIX C

Attach ram air cylinder and ram air pressure transducer to air supply. Attach recorder to transducer.

5.2.2 Load application. — Start recorder and apply air pressure with axial load air regulator in increasing increments. Record axial load (lbs) on Dillon cell at each pressure increment.

5.3 Deflection Calibration

5.3.1 Set up. — Attach potentiometers to galvanometers and power supply. Attach deflection cables to shafts of potentiometers.

5.3.2 Deflection application. — Move the cables in fixed increments of distance and record the galvanometer deflections at each. Plot cable displacement versus galvanometer deflection to obtain calibration curve.

6.0 TEST SEQUENCE

6.1 Specimen Mounting

(a) Align index mark on moveable end plate with zero mark on frame and position rubber gaskets around both end plates.

(b) Carefully slide specimen over end plates. Install rubber band gaskets over specimen at each end plate.

(c) Apply 15 to 20 psi air pressure to axial load cylinder. Apply sufficient internal pressure from the dry Nitrogen supply to straighten seams and remove wrinkles from specimen.

(d) Place metal band clamps over gaskets on end plates and tighten securely.

(e) Apply 30 in. H_2O internal pressure with nitrogen supply and inspect specimen for leaks. Small leaks may be sealed with pressure sensitive tape.

(f) Set all pressure gages to zero.

6.2 Cold Chamber Installation

(a) Center cold chamber over mounted specimen. Attach liquid nitrogen supply and thermocouple wires.

(b) Attach cables from potentiometer No. 1 and 2 to tabs on cylinder. Wind

APPENDIX C

cable from potentiometer No. 3 around middle circumference of specimen and secure free end to frame.

(c) Set temperature controller at the specified test temperature. Turn on the liquid nitrogen supply and the temperature recorder.

6.3 Load Application

(a) Check output of power supply. Set all gages and potentiometers at zero. Start recorder and make calibration deflection.

(b) Set regulator on dry nitrogen supply at 10 psi. Raise internal pressure to specified value obtained from calibration curve by means of valve on control panel.

(c) Set axial load direction valve to "+" or "-" (extension or retraction). Raise pressure on axial load cylinder to specified value obtained from calibration curve with valve on control panel.

(d) Set torque direction valve to "+". Raise pressure on torque cylinder with valve on control panel until specimen bursts.

(e) Set all gages and potentiometer to zero. Make calibration deflection on recorder. Turn off recorders, temperature recorder and power supply.

(f) Remove the three extension cables and the cold chamber from the specimen. Remove the specimen from the apparatus.

6.4 Documentation

(a) Identify the specimen and the recorder chart with the material designation and a specimen and test number.

(b) Record the internal pressure, axial load and torque at burst on the chart.

(c) Calculate the hoop stress from the relation:

$$(\text{Hoop stress in lbs/in}) = 3.5 \times (\text{Internal pressure at burst in psi})$$

(d) Calculate the axial stress from the relation:

$$(\text{Axial stress in lbs/in}) = 3.5 \times (\text{Internal pressure at burst in psi}) + (\text{Axial load from calibration curve in lbs}) \div 44.0 \text{ inches.}$$

(e) Report the hoop stress, axial stress and torque at burst.