

67-27251

NATIONAL AERONAUTICS AND SPACE ADMINISTRATION

*Technical Report 32-1559*

*Digital Canopus Tracker  
Digital Electronics*

*W. E. Crawford*

**CASE FILE  
COPY**

**JET PROPULSION LABORATORY  
CALIFORNIA INSTITUTE OF TECHNOLOGY  
PASADENA, CALIFORNIA**

July 1, 1972

NATIONAL AERONAUTICS AND SPACE ADMINISTRATION

*Technical Report 32-1559*

*Digital Canopus Tracker*  
*Digital Electronics*

*W. E. Crawford*

---

**JET PROPULSION LABORATORY**  
**CALIFORNIA INSTITUTE OF TECHNOLOGY**  
**PASADENA, CALIFORNIA**

July 1, 1972

## **Preface**

The work described in this report was performed by the Guidance and Control Division of the Jet Propulsion Laboratory.

# Contents

<b>I. Introduction</b>	<b>1</b>
<b>II. Basic Digital Canopus Tracker Circuits</b>	<b>1</b>
<b>III. Digital Closed-Loop Electro-Optical Control System</b>	<b>1</b>
<b>IV. Acquisition Logic</b>	<b>2</b>
<b>V. Programmable Intensity Gates</b>	<b>2</b>
<b>VI. Particle Rejection Features of the Digital Tracker</b>	<b>5</b>
<b>VII. Roll Error Circuitry</b>	<b>5</b>
<b>VIII. Explanation of Signals and Circuits</b>	<b>6</b>
<b>IX. Future Work</b>	<b>7</b>

## Figures

1. Digital Canopus tracker block diagram	3
2. Digital Canopus tracker acquisition logic	4
3. Roll error shift register mode control sequence	5
4. Digital Canopus tracker digital electronics schematic	9
5. Digital electronics breadboard	10
6. Digital electronics control box	10

## **Abstract**

Circuitry has been developed for digital control of the Canopus tracker. A feasibility and demonstration breadboard has been constructed using microelectronic integrated circuits. The breadboard contains the digital circuits necessary for closed-loop electro-optical control of the tracker. Also included in the breadboard is the digital logic necessary for star acquisition, particle rejection, programmable gate selection, cone angle selection, and routing of the digital roll error signal.

# Digital Canopus Tracker Digital Electronics

## I. Introduction

This report summarizes the effort to date in the design, breadboarding, and testing of the digital electronics for a digital Canopus tracker. The long-range objective of this effort is to develop a digital star tracker for use in the attitude control subsystems of future spacecraft.

The attitude control subsystems technology now under development for future missions is based on digital techniques and makes use of a central processing unit, a digital inertial reference unit, and a digital sun sensor. The development of a digital star tracker is a necessary part of this technology.

## II. Basic Digital Canopus Tracker Circuits

Figure 1 is a block diagram of the digital Canopus tracker. Shown on the diagram are both the analog and high-voltage sections of the tracker along with the digital circuits. The dotted line shows the separation between the analog control circuits and the digital control circuits. This report concerns itself mainly with the digital circuitry. The digital circuitry is made up of TTL low-power microcircuits. Operational amplifiers are used for digital-to-analog converters and for voltage comparators. A detailed

discussion is presented of the following circuits shown in Fig. 1:

- Voltage-controlled oscillator.
- Count-up/count-down logic.
- Digital integrator (11 bit).
- Roll error shift register (11 bit).
- Precision digital/analog converter (11 bit).
- Acquisition logic circuits.
- Count-up bias.
- High gate latch.
- Programmable gate circuits.
- High gate/low gate and cone angle D/A converters.

Also discussed are the principal Canopus tracker modes: *Canopus acquisition*, *search*, and *fly back and sweep*. The Canopus tracker intensity signal is used as an input to the programmable gates; this signal is also discussed.

## III. Digital Closed-Loop Electro-Optical Control System

The Canopus tracker operates in a closed-loop servo control mode when it is tracking a star. This electro-optical control system tends to keep the star centered within a nar-

row field of view once a star of the correct intensity is acquired. The elements of the closed-loop control system are shown in Fig. 1. As indicated in the upper left portion of the diagram, starlight entering the Canopus tracker travels first through a baffle, then a sun shutter, and then on to an objective lens which focuses the light on an image dissector tube. The purpose of the baffle is to prevent unwanted stray light from reaching the tracker optics. The sun shutter is another protection device that is actuated if the sun gets near the tracker field of view.

When the starlight reaches the image dissector tube it is converted to an electrical signal. This signal is amplified by the image dissector tube and by the preamplifier. The demodulator then receives the signal, detects phase, and delivers a dc voltage to the voltage-controlled oscillator. This voltage is variable in both polarity and amplitude and determines if the voltage-controlled oscillator will issue count-up pulses or count-down pulses and what the pulse rate will be.

The pulses from the VCO are routed through the count-up/count-down logic and then into the digital integrator. The digital integrator stores the pulse count, transfers position information to the roll error shift register, and controls the input to the 11-bit digital-to-analog converter. The voltage output of the D/A converter is used to control the roll deflection amplifiers. These amplifiers provide high voltage for the image dissector tube deflection plates. The voltage on these plates controls the position of the electron beam within the tube, and in this way the loop is closed. Thus, from star image around the loop to the deflection plates, the system automatically aligns itself to place the star in the center of the scan field of view.

The loop is closed by the VCO enable line. This line allows the VCO pulses to pass on to the digital integrator, thereby closing the loop. The acquisition logic, along with the programmable gates, determines if a star of the right intensity is in the field of view. If so, the loop is closed and automatic star tracking takes place.

#### IV. Acquisition Logic

Figure 2, the digital Canopus tracker acquisition logic diagram, shows the three principal modes of the tracker — *search*, *Canopus acquisition*, and *fly back and sweep* — and the logic path between them. Following is a brief description of the principal modes:

(1) *Search*. In this mode, the Canopus tracker field of view is biased into the search position and the spacecraft is turned slowly about the roll axis. This allows stars to

appear in the field of view and to sweep across the face of the tracker. If a star of the correct intensity appears, the acquisition logic is satisfied and automatic star tracking takes place. In the *search* mode, the VCO is disabled and the count-up bias is enabled. This places the tracker in open-loop operation, biased to the search position of the field of view.

(2) *Acquisition*. When the star intensity voltage is between the low gate and high gate, the conditions for star acquisition are satisfied. In this mode, the VCO is enabled, thus closing the electro-optical tracking loop. An acquisition signal is given to the attitude control subsystem, enabling Canopus tracker control of the roll axis of the spacecraft. The count-up bias circuit is disabled during acquisition, and the logic counter is also disabled.

(3) *Fly Back and Sweep*. In this mode, the tracker field of view is commanded to the fly back position (opposite to search position) and commanded to slowly sweep across the face of the tracker looking for a star to satisfy the intensity gates. The *fly back and sweep* sequence can be initiated either internally in the tracker or externally in the attitude control subsystem. The internal *fly back and sweep* sequence is initiated each time Canopus acquisition is lost. The tracker performs the *fly back and sweep* automatically and may reacquire Canopus on the sweep. The external command for *fly back and sweep* is given by the attitude control subsystem in order to cause the tracker to sweep its total field of view. During *fly back and sweep*, the VCO is disabled, the digital integrator is reset, and the count-up bias is introduced into the integrator, causing a sweep of the full field of view. If Canopus is not acquired on the sweep, the count-up bias continues until the digital integrator is in the search position.

From Figure 2 it can be seen that when the tracker is in the *search* mode and a star of the correct intensity appears in the field of view, then Canopus acquisition will take place 2.56 seconds later. When the tracker is in the *Canopus acquisition* mode, and if there is a continuous violation of either the high gate or low gate for 2.56 seconds, then the *fly back and sweep* sequence is initiated. If, during *fly back and sweep*, Canopus is reacquired, then the Canopus tracker returns to the *Canopus acquisition* mode. If Canopus is not reacquired then the *search* mode is re-established.

#### V. Programmable Intensity Gates

The programmable intensity gates, selectable by external command, allow a wide range of star intensities to be selected for star acquisition. This feature will be very

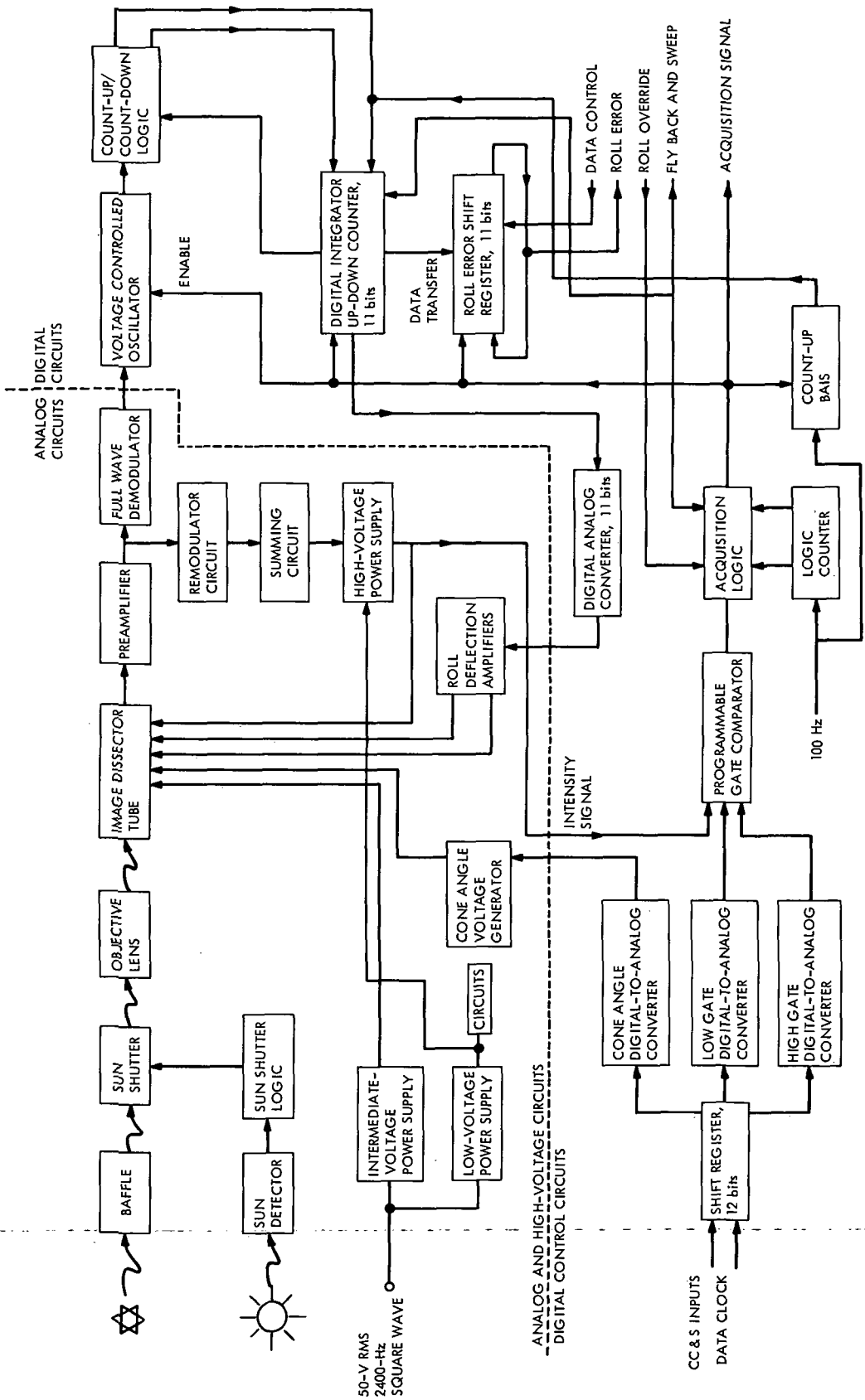

Fig. 1. Digital Canopus tracker block diagram



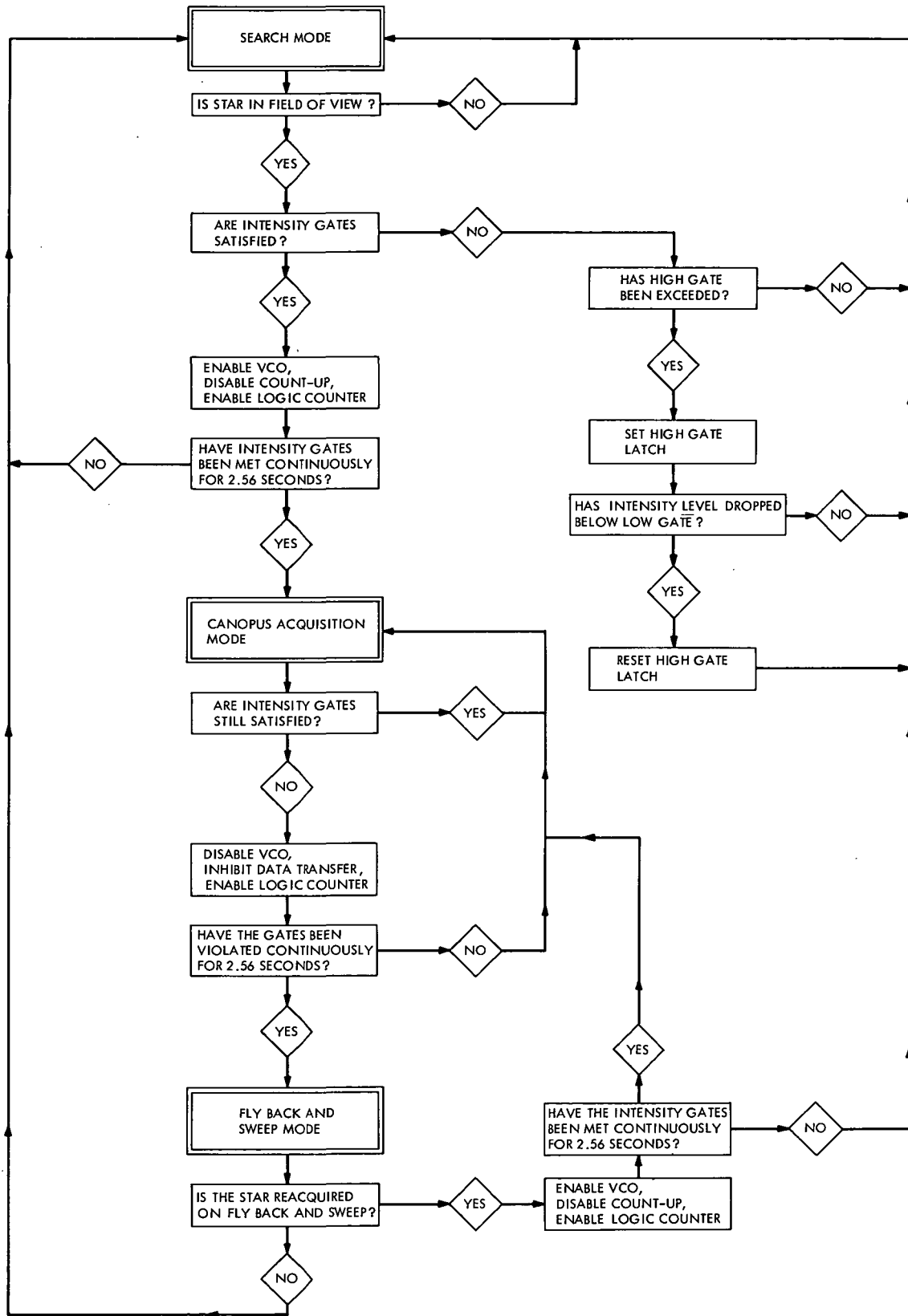

Fig. 2. Digital Canopus tracker acquisition logic

important on "long lifetime" spacecraft missions. Because of possible degradation of the image dissector tube sensitivity over operating periods of from six to 10 years, the requirement to have adjustable high and low gates is mandatory.

Two digital-to-analog converters along with the high gate and low gate comparators form the programmable gate circuits; 16 low gate and 16 high gate settings are available upon command. These circuits are able to:

- (1) Select stars of differing intensities.
- (2) "Open the gates," allowing the tracker to track any star in its field of view.
- (3) Exclude star acquisition by overlapping gate settings, giving the tracker star mapping capabilities.
- (4) "Narrow" the gates to a very narrow range of intensities, allowing the acquisition of a specific star among many with similar but not identical intensity.

## VI. Particle Rejection Features of the Digital Tracker

Small particles that adhere to the spacecraft are occasionally dislodged during the mission, and a small percentage of these particles pass through the tracker field of view. The incidence of particles is higher when the spacecraft has been mechanically disturbed by an event such as *gyros on*, *scan slew*, or a gas jet firing. The particles are accelerated by solar pressure and illuminated by sunlight. They are probably tumbling at a slow rate, and they are in the field of view for generally less than 1 or 2 seconds.

In order to make the tracker insensitive to these particles, the following particle rejection features have been incorporated into the digital Canopus tracker:

- (1) VCO Clamp. This feature limits the frequency of the VCO, thereby limiting the ability of the closed-loop

electro-optical servo to follow fast moving particles. This feature does not affect open-loop operation such as roll override or *fly back and sweep*.

- (2) Timed Logic. Once Canopus is acquired, the high gate or low gate must be violated continuously for 2.56 seconds before a *fly back and sweep* is issued. This prevents momentary particles from causing *fly back and sweep* to be activated.

- (3) Gate violation. This feature prevents closed-loop optical tracking unless the gates are satisfied. Most particles entering the field of view cause a momentary violation of the high gate. This opens the loop and "freezes" the system until the intensity signal level comes back within the gates. Using this system, the tracker should not be able to track off of Canopus even though multiple particles enter the field of view.

## VII. Roll Error Circuitry

The roll error shift register stores the Canopus position error and makes the information available to the attitude control central processing unit (CPU). This circuit is an 11-bit serial shift register. The attitude control system has control of the clock and mode lines of the register in order to transfer the roll error digital word into the attitude control central processing unit. The roll error register is loaded in parallel from the digital integrator. In normal operation (*Canopus acquisition*), the shift register data is transferred to attitude control and reloaded back into the register. On the next mode pulse from attitude control, the register is updated by the digital integrator. In other modes, such as *fly back and sweep* and *search*, the roll error register is not updated and the last data word is cycled through the register each time attitude control transfers a word.

Figure 3 shows the timing signals necessary to control the roll error data transfer. These timing signals are re-

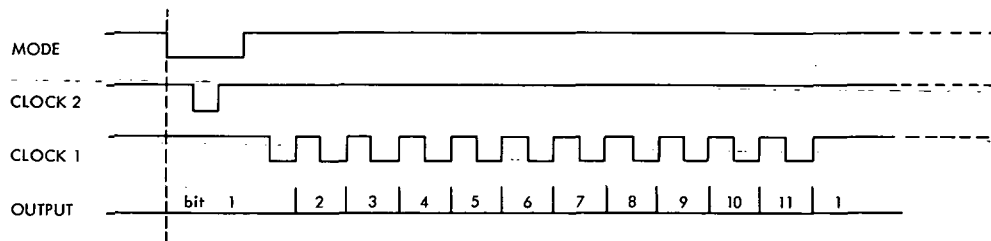

Fig. 3. Roll error shift register mode control sequence

ceived from the attitude control CPU. The roll error 11-bit word is transferred 10 times per second (one cycle time = 100 ms).

## VIII. Explanation of Signals and Circuits

Following are brief discussions of the more important signals and circuits that make up the digital Canopus tracker. This explanatory material along with the Canopus tracker block diagram (Fig. 1) and the digital electronics schematic (Fig. 4) should enable the reader to understand in detail the operation of the digital tracker. The digital electronics breadboard and control box are shown in Figs. 5 and 6.

(1) Canopus Acquisition Signal. This signal is generated after the Canopus intensity signal has continuously met the low gate/high gate comparator threshold for a period of 2.56 seconds.

(2) Loss of Canopus Acquisition Signal. After Canopus acquisition, a continuous violation of either the high gate or low gate for a period of 2.56 seconds will cause a loss of the Canopus acquisition signal. Also, at this time, a *fly back and sweep* is executed in an attempt to reacquire the star.

(3) Intensity Signal. This variable voltage signal is proportional to star intensity and is compared with the high gate and low gate voltage threshold in the programmable gate comparator. Signals from the comparator then act to control the acquisition logic circuits.

(4) *Fly Back and Sweep* Sequence. This is a mode wherein the digital integrator is reset (all zeros) and a count-up bias is then introduced into the integrator (up-down counter). Since the digital integrator controls the position of the image dissector scan through the 11-bit D/A converter and the roll deflection amplifiers, resetting the integrator causes a *fly back* and introducing a count-up bias into the integrator causes a *sweep*. The *fly back and sweep* mode can be initiated by internal logic (acquisition logic) or by external command (CC&S or attitude control). After Canopus acquisition, a violation of either the high gate or low gate continuously for 2.56 seconds will cause initiation of the *fly back and sweep* mode.

(5) Roll Override (Search). This is an external command issued by CC&S. This command resets the Canopus acquisition signal, loads all "ones" into the eight

most significant bits of the digital integrator, and forces the tracker to lose lock on the star it has acquired and move to the search position.

(6) VCO Enable. This internal command is issued whenever the star intensity signal is within the high gate and low gate threshold. This command enables the closed-loop electro-optical control system and allows closed-loop optical tracking of the star.

(7) Count-Up Bias. This circuit enables the count-up input to the digital integrator and causes the tracker to stay in the search portion of the optical field of view. Count-up bias also causes the tracker to sweep across its field of view during the *fly back and sweep* sequence. The count-up bias is enabled if the star intensity signal is not within the high gate and low gate threshold. At star acquisition, the count-up bias is disabled. After Canopus acquisition, a continuous violation of either the high gate or low gate for a period of 2.56 seconds causes the count-up bias to be enabled along with the *fly back and sweep* command.

(8) Cone Angle Circuit. This is a 4-bit D/A converter that decodes the binary information in the input shift register and selects one of 16 discrete voltages. This voltage is then input to the cone angle voltage generator, which applies voltages to the cone deflection plates in the image dissector tube.

(9) High Gate Latch Circuit. This flipflop is part of the acquisition logic and is used to prevent the tracker from locking on a bright object such as the moon or earth limb. If, in the *search* mode, the intensity signal causes a high gate violation, the high gate latch is set. The intensity signal must then go below the low gate threshold prior to acquisition. During the star acquisition mode, the high gate latch is locked out of the circuit so that momentary violations of the high gate due to particle reflections do not cause loss of acquisition.

(10) Logic Counter Circuit. The logic counter is a binary counter that has an input clock running at 100 Hz. Each time the programmable gates change state, the counter is reset to zero and the counter is then used as a time delay to initiate various modes such as *Canopus acquisition*, *fly back and sweep*, *loss of Canopus acquisition* and *count-up enable*. The counter has 8 bits and fills completely in 2.56 seconds. The counter recycles continuously when a star is not acquired. When star acquisition takes place, the counter stops counting when it is full.

(11) Voltage Controlled Oscillator. This circuit receives as an input the voltage from the demodulator and issues either a count-up or count-down pulse to the digital integrator. When the VCO is enabled, the tracker electro-optical control loop is closed and the tracker is in the automatic optical tracking mode. The VCO responds to both polarity and amplitude of the input signal from the demodulator. The input of the VCO contains a zener diode voltage clamp that will limit the upper frequency of the VCO, thereby limiting the closed-loop optical tracking rate of the Canopus tracker. This prevents the tracker from following illuminated particles and helps in the overall problem of particle rejection.

(12) Digital Integrator (Up-Down Counter). This digital integrating circuit is made up of three medium-scale integration (MSI) microcircuits. It accepts inputs from the VCO and count-up/count-down logic during closed-loop optical tracking. During *search*, the counter is loaded with all "ones." During *fly back and sweep*, the counter is reset to all zeros. After *fly back*, the count-up bias causes the counter to integrate up, which causes the image dissector tube to sweep its field of view. The digital integrator provides outputs to the count-up/count-down logic, the roll error shift register, and the 11-bit precision D/A converter.

## IX. Future Work

Circuit development tasks that are intended to yield circuits and functional operations consistent with outer planet mission flight requirements and are necessary to upgrade the quality of the present digital electronics are listed below:

(1) Adaptive Gate Levels. The current implementation provides for 16 high gate and 16 low gate levels which are

preset by means of a 4-bit byte. The design and performance of the adaptive gate circuitry is considered satisfactory. However, the number of gate levels provided for both high and low gates will be reviewed after breadboard testing has been completed.

(2) Roll Error Register Output Format. The format of the roll error output signal is currently undefined as to whether a serial or parallel transfer should take place between the digital star tracker roll error register and the attitude control electronics. In either event no new design will be required for the star tracker since provisions have been made for either type of data transfer.

(3) Logic Register. During the breadboard tests, a determination will be made as to whether the acquisition mode times are appropriate. In the event that these delay times are changed, no new circuit design should be necessary but circuit wiring modifications would be required.

(4) Timing Oscillator. A redesign should be performed on this circuit in an effort to improve the stability and accuracy of the timing signals provided. The redesign will probably involve counting-down the 4800-Hz primary power frequency to 100 Hz. A larger chip count will undoubtedly result from this redesign.

(5) Roll Register D/A Converter. The D/A converter currently being used is a commercial unit which is unsatisfactory as a final flight component. A design of an 11-bit D/A converter using flight-approved parts will be undertaken in the near future.

(6) Buffer Circuits. Interface circuits between the digital star tracker and spacecraft subsystems must be examined in terms of noise immunity and isolation. Some redesign may be necessary.

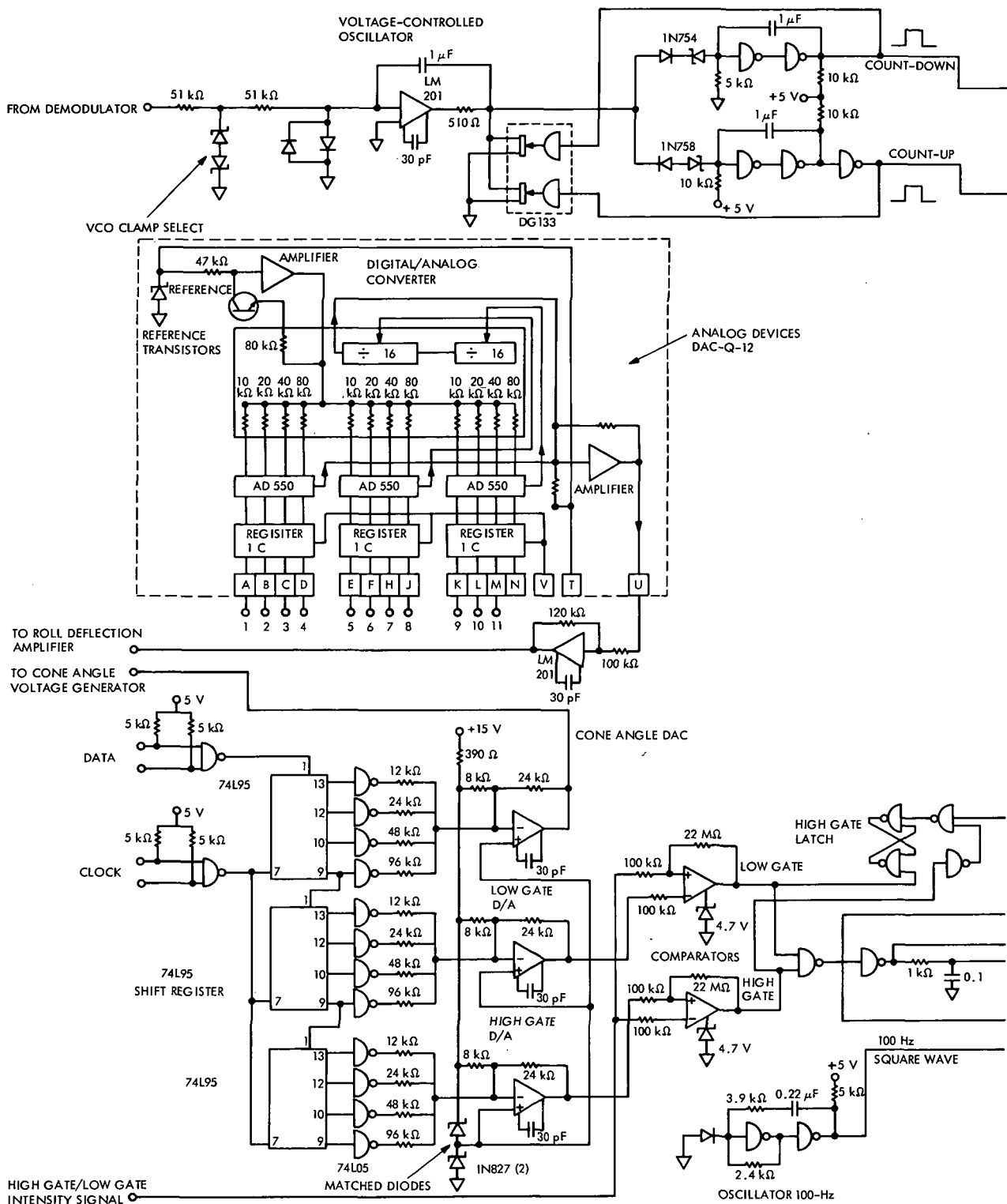

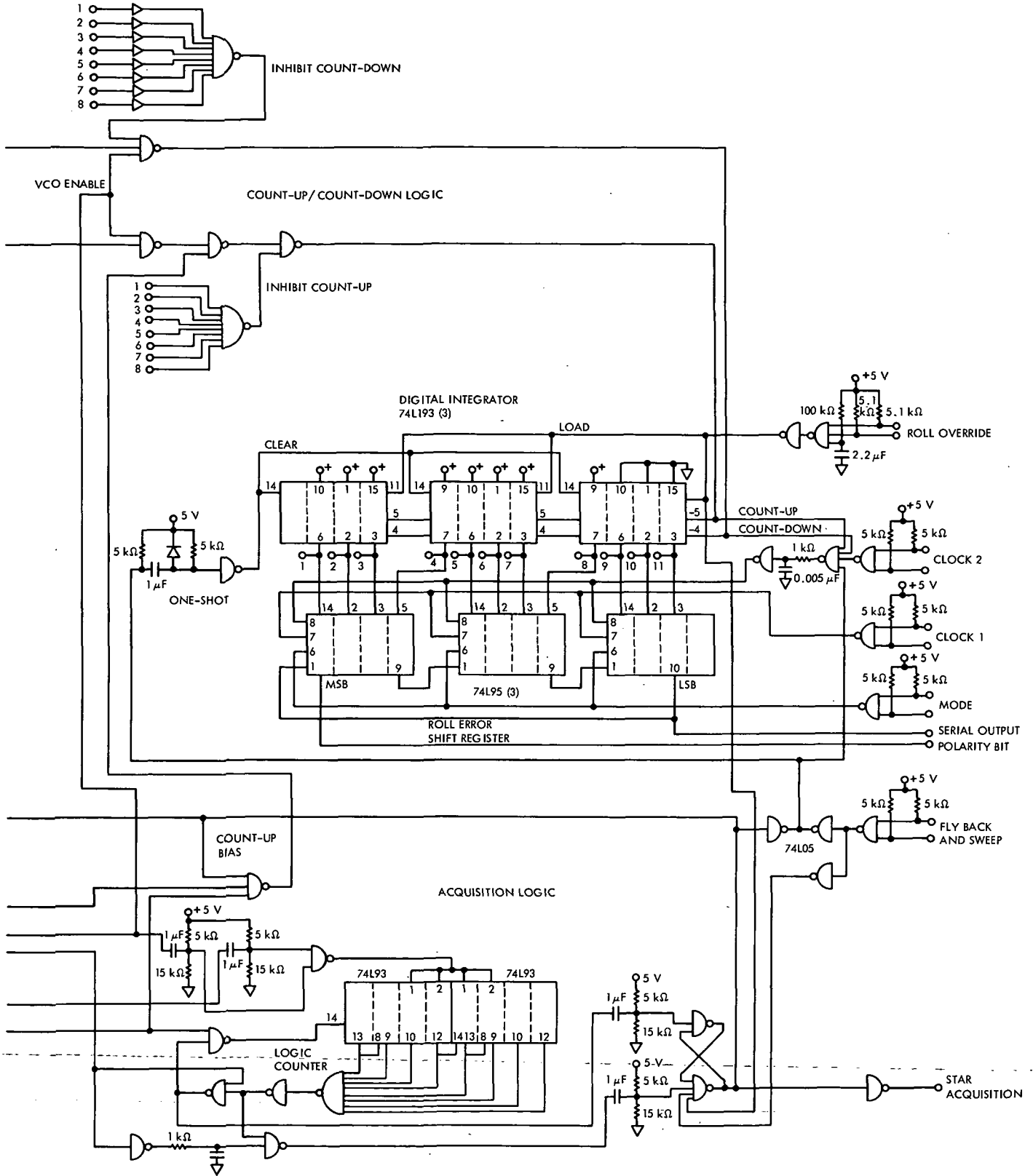

Fig. 4. Digital Canopus tracker digital electronics schematic

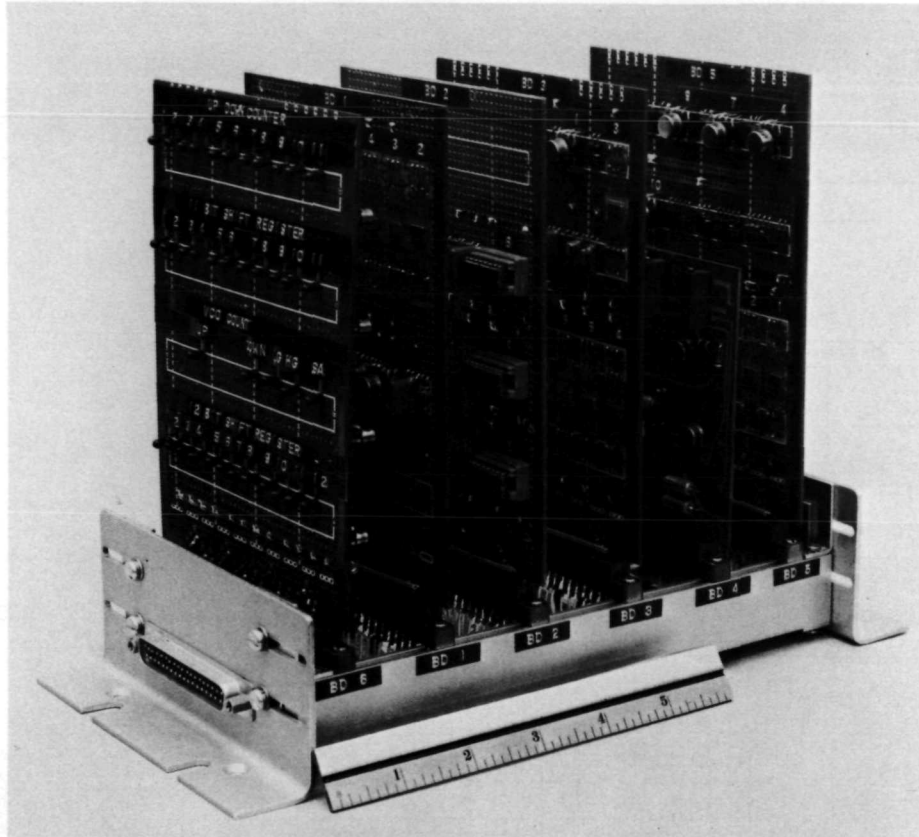

Fig. 5. Digital electronics breadboard

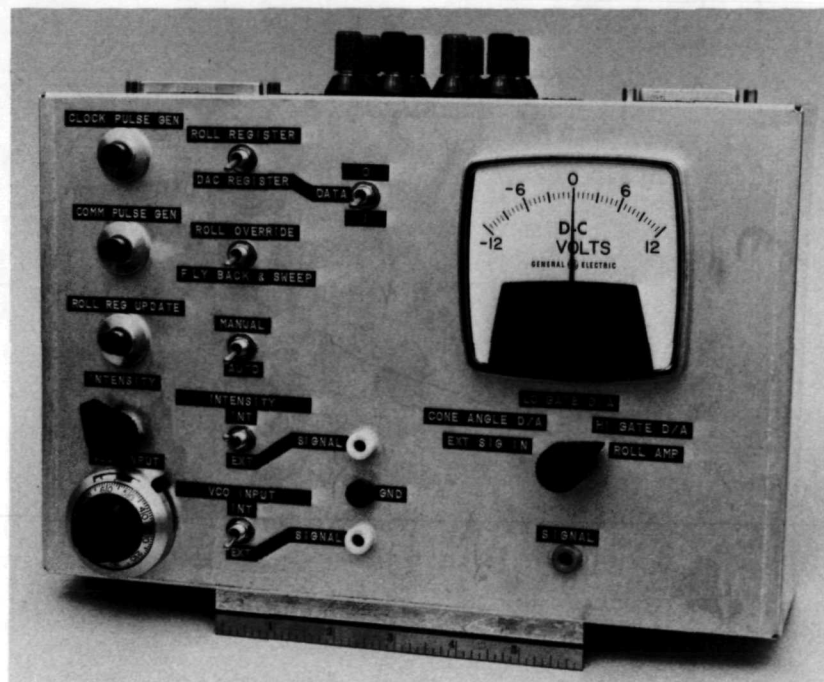

Fig. 6. Digital electronics control box

1. Report No. 32-1559	2. Government Accession No.	3. Recipient's Catalog No.	
4. Title and Subtitle  DIGITAL CANOPUS TRACKER DIGITAL ELECTRONICS		5. Report Date July 1, 1972	
		6. Performing Organization Code	
7. Author(s) W. E. Crawford		8. Performing Organization Report No.	
9. Performing Organization Name and Address JET PROPULSION LABORATORY California Institute of Technology 4800 Oak Grove Drive Pasadena, California 91103		10. Work Unit No.	
		11. Contract or Grant No. NAS 7-100	
		13. Type of Report and Period Covered  Technical Report	
12. Sponsoring Agency Name and Address  NATIONAL AERONAUTICS AND SPACE ADMINISTRATION Washington, D.C. 20546		14. Sponsoring Agency Code	
15. Supplementary Notes			
16. Abstract  Circuitry has been developed for digital control of the Canopus tracker. A feasibility and demonstration breadboard has been constructed using microelectronic integrated circuits. The breadboard contains the digital circuits necessary for closed-loop electro-optical control of the tracker. Also included in the breadboard is the digital logic necessary for star acquisition, particle rejection, programmable gate selection, cone angle selection, and routing of the digital roll error signal.			
17. Key Words (Selected by Author(s))  Control and Guidance Electronic Components and Circuits Interplanetary Spacecraft, Advanced Optics		18. Distribution Statement  Unclassified -- Unlimited	
19. Security Classif. (of this report)  Unclassified	20. Security Classif. (of this page)  Unclassified	21. No. of Pages  10	22. Price



## HOW TO FILL OUT THE TECHNICAL REPORT STANDARD TITLE PAGE

Make items 1, 4, 5, 9, 12, and 13 agree with the corresponding information on the report cover. Use all capital letters for title (item 4). Leave items 2, 6, and 14 blank. Complete the remaining items as follows:

3. Recipient's Catalog No. Reserved for use by report recipients.
7. Author(s). Include corresponding information from the report cover. In addition, list the affiliation of an author if it differs from that of the performing organization.
8. Performing Organization Report No. Insert if performing organization wishes to assign this number.
10. Work Unit No. Use the agency-wide code (for example, 923-50-10-06-72), which uniquely identifies the work unit under which the work was authorized. Non-NASA performing organizations will leave this blank.
11. Insert the number of the contract or grant under which the report was prepared.
15. Supplementary Notes. Enter information not included elsewhere but useful, such as: Prepared in cooperation with... Translation of (or by)... Presented at conference of... To be published in...
16. Abstract. Include a brief (not to exceed 200 words) factual summary of the most significant information contained in the report. If possible, the abstract of a classified report should be unclassified. If the report contains a significant bibliography or literature survey, mention it here.
17. Key Words. Insert terms or short phrases selected by the author that identify the principal subjects covered in the report, and that are sufficiently specific and precise to be used for cataloging.
18. Distribution Statement. Enter one of the authorized statements used to denote releasability to the public or a limitation on dissemination for reasons other than security of defense information. Authorized statements are "Unclassified-Unlimited," "U. S. Government and Contractors only," "U. S. Government Agencies only," and "NASA and NASA Contractors only."
19. Security Classification (of report). NOTE: Reports carrying a security classification will require additional markings giving security and downgrading information as specified by the Security Requirements Checklist and the DoD Industrial Security Manual (DoD 5220.22-M).
20. Security Classification (of this page). NOTE: Because this page may be used in preparing announcements, bibliographies, and data banks, it should be unclassified if possible. If a classification is required, indicate separately the classification of the title and the abstract by following these items with either "(U)" for unclassified, or "(C)" or "(S)" as applicable for classified items.
21. No. of Pages. Insert the number of pages.
22. Price. Insert the price set by the Clearinghouse for Federal Scientific and Technical Information or the Government Printing Office, if known.