

COPY #7

N72-27064

DMS-DR-1264

LEE LUCIER

CR-120,049

CASE FILE COPY

VOLUME I

JUNE 1972

—SPACE SHUTTLE—

ASCENT HEAT TRANSFER RATE DISTRIBUTION ON THE NR DELTA WING ORBITER AND THE GD/C BOOSTER AT MACH NUMBER OF 8

[MATED]

by

R. K. Matthews, ARO, INC.
W. R. Martindale, ARO., INC
J. D. Warmbrod, MSFC

VKF 50 INCH HYPERSONIC
TUNNEL 3

Arnold Engineering
Development Center

SADSAC SPACE SHUTTLE
AEROTHERMODYNAMIC
DATA MANAGEMENT SYSTEM

CONTRACT NAS8-4016
MARSHALL SPACE FLIGHT CENTER

This document should
be referenced as NASA
CR-120,049

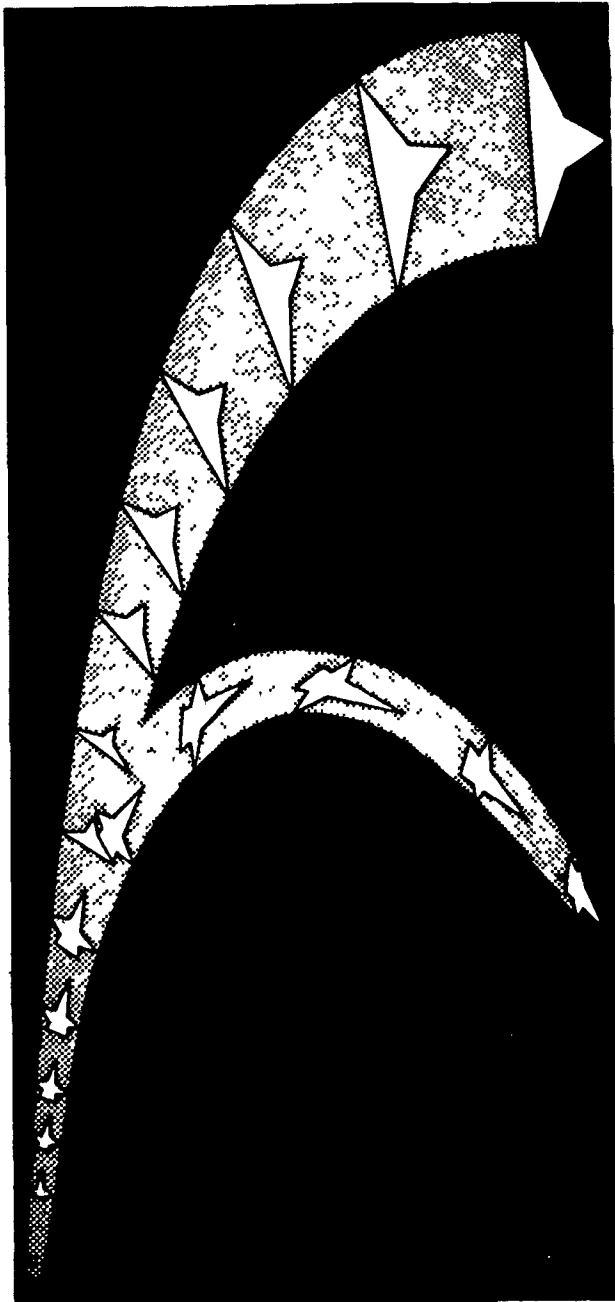

NASA Series Number: H-1010

DMS-DR-1264
CR-120,049
VOLUME I
JUNE, 1972

SADSAC/SPACE SHUTTLE

WIND TUNNEL TEST DATA REPORT

CONFIGURATION: North American Rockwell Delta Wing Orbiter (NAR-DWO)
Mated With The General Dynamics Convair Booster (GDC-B)

TEST PURPOSE: To Determine the Interference Heating at a Mach Number of 8

TEST FACILITY: AEDC VKF 50-Inch Hypersonic Tunnel B

TESTING AGENCY: AEDC-MSFC

TEST NO. & DATE: VT1162-11; June, 1971

FACILITY COORDINATOR: L. L. Trimmer, ARO, Inc.

PROJECT ENGINEER(S): R. K. Matthews, ARO, Inc.
W. R. Martindale, ARO, Inc.
J. D. Warmbrod, MSFC

DATA MANAGEMENT SERVICES

LIAISON:

J. S. Glyn
FOR E. Vaughn

DATA OPERATIONS:

J. R. Ziler
J. R. Ziler

RELEASE APPROVAL:

J. S. Glyn
FOR D. Kemp, Supervisor
Aero Thermo Data Group

CONTRACT NAS 8-4016

AMENDMENT 158

DRL 297 - 84a

This report has been prepared by Chrysler Corporation Space Division under a Data Management Contract to the NASA. Chrysler assumes no responsibility for the data presented herein other than its display characteristics.

FACILITY COORDINATOR:

Mr. L. L. Trimmer, ARO, INC.
Arnold Engineering Development Center
Arnold Air Force Station, Tennessee 37389

Phone: (615) 455-2611-X7377

PROJECT ENGINEERS:

Mr. R. K. Matthews, ARO, INC.
Arnold Engineering Development Center
Arnold Air Force Station, Tennessee 37389

Phone: (615) 455-2611-X594

Mr. W. R. Martindale, ARO, INC.
Arnold Engineering Development Center
Arnold Air Force Station, Tennessee 37389

Phone: (615) 455-2611-X575

Mr. J. D. Warmbrod
Marshall Space Flight Center
S&E-AERO-AF, Building 4610
Huntsville, Alabama 35801

Phone: (205) 453-0170

SADSAC LIAISON:

Mr. J. E. Vaughn
Chrysler Space Division
102 Wynn Drive
Department 4820
Huntsville, Alabama 35805

Phone: (205) 895-1560

SADSAC OPERATIONS:

Mr. J. R. Ziler
Chrysler Corp. Space Division
P. O. Box 29200
Department 2780
New Orleans, Louisiana 70129

Phone: (504) 255-2304

FOREWORD

The work reported herein was sponsored by the Marshall Space Flight Center (MSFC), NASA. The results of tests presented were obtained by ARO, Inc. (a subsidiary of Sverdrup and Parcel & Associates, Inc.), contract operator of the Arnold Engineering Development Center (AEDC), AFSC, Arnold Air Force Station, Tennessee. Ascent and reentry conditions were simulated on shuttle models designed by McDonnell Douglas (MDAC), North American Rockwell (NAR) and General Dynamics Convair (GDC). In addition a limited amount of data were obtained on two research models provided by the Langley Research Center (LRC). Because of the broad scope of these tests the data will be presented in a series of SADSAC reports. This report presents the results of the phase-change paint test conducted at Mach 8 in Tunnel B on the NAR Delta Wing Orbiter mated with the GDC-booster. This volume (Volume I) contains the mated data and Volume II contains the interference-free data for the orbiter and booster alone.

CONTENTS

<u>Section</u>		<u>Page</u>
	LIST OF FIGURES	iv
	LIST OF TABLES	iv
	NOMENCLATURE	v
1.	INTRODUCTION	1
2.	MODELS AND APPARATUS	2
	2.1 Model Description	2
	2.2 Facility Description	2
3.	PROCEDURES	3
	3.1 Test Techniques	3
	3.2 Test Conditions	3
	3.3 Data Reduction	4
4.	DATA PRESENTATION	4
	REFERENCES	5

LIST OF FIGURES

<u>Figure</u>	<u>Page</u>
1. North American Rockwell Delta Wing Orbiter Model Sketch (0.013 Scale)	6
2. General Dynamics Convair Booster Model Sketch (0.013 Scale)	7
3. Model Photograph	8

LIST OF TABLES

<u>Table</u>	
1. Configuration Description Details	9 - 18
2. Model Coordinates	19 - 41
3. Phase-Change Coating Test Data Summary Sheets	42 - 43
4. Summary Data Index	44

NOMENCLATURE

ALPHA-MODEL (α)	Model angle of attack, deg
ALPHA-PREBEND	Sting prebend angle, deg
ALPHA-SECTOR	Tunnel sector pitch angle, deg
H(T ₀) or H	Heat-transfer coefficient based on T _{aw} = T ₀ , BTU/ft ² - sec - °R, and

$$H(T_0) = \frac{\beta \sqrt{\rho c k}}{\sqrt{\Delta t}}$$

where β is obtained from

$$\frac{T_{pc} - T_i}{T_{aw} - T_i} = 1 - e^{-\beta^2} \operatorname{erfc} \beta$$

and $\Delta t \sim$ del time

$T_{pc} \sim$ phase-change point temperature, °R

$T_i \sim$ initial model temperature, °R

$T_{aw} \sim$ adiabatic wall temperature, °R

$\sqrt{\rho c k} \sim$ model material properties = 0.11-0.008 $\sqrt{(\Delta t)}$
BTU/ft²-sec^{1/2} - °R

H(.9T ₀)	Heat transfer coefficient based on T _{aw} = 0.9T ₀
H(.85T ₀)	Heat transfer coefficient based on T _{aw} = .85T ₀
HREF	Reference heat transfer coefficient based on Fay-Riddell theory, BTU/ft ² -sec °R

$$HREF = \left[\frac{8.139(P01)^{0.5} (MU-0)^{0.4} (1-P-INF/P01)^{0.25}}{(RN)^{0.5} (T0)^{0.15}} \right] \times [0.2235 + 0.0000135 (T_0 + 760)]$$

where P01 \sim stagnation pressure downstream of a normal shock, psia

MU-0 \sim air viscosity based on T₀, lbf sec/ft²

RN \sim reference nose radius, (0.013 ft)

MU-INF	Free-stream viscosity, lb-sec/ft ²
P-INF	Free-stream static pressure, psia
P0	Tunnel stilling chamber pressure, psia
Q-INF	Free-stream dynamic pressure, psia
RE/FT	Free-stream unit Reynolds number, ft ⁻¹
ROLL-MODEL	Model roll angle, deg
ST(T0)	Stanton number based on T ₀ ,
	$ST(T_0) = \frac{H(T_0)}{\rho_\infty V_\infty [0.2235 + 0.0000135 (T_0 + T_{PC})] \times (32.17)}$
STREF	Reference Stanton number
	$STREF = \frac{HREF}{\rho_\infty V_\infty [0.2235 + 0.0000135 (T_0 + T_{PC})] \times (32.17)}$
T-INF	Free-stream static temperature, °R
T0	Tunnel stilling chamber temperature, °R
TW	Model wall temperature, °R
TIME	Time from start of model injection, sec
DEL TIME (Δt)	Time model exposed to airstream, sec
V-INF (V _∞)	Free-stream velocity, ft/sec
YAW	Model yaw angle, deg
X	Axial distance from booster nose to orbiter nose (-3.21 in.)
Z	Gap spacing between booster and orbiter (0.312 in.)

SECTION 1
INTRODUCTION

This report presents the results of a wind tunnel test program to determine aerodynamic interference heating on the North American Rockwell orbiter mated with the General Dynamics Convair Booster. The tests were conducted at the Arnold Engineering Development Center (AEDC) in Tunnel B of the von Karman Gas Dynamics Facility (VKF). The test period was June 1971.

Heat-transfer rates were determined by the phase-change paint technique on 0.013-scale Stycast[®] models using Tempilaq[®] as the surface temperature indicator. The nominal test conditions were; Mach 8, free-stream unit length Reynolds numbers of 1.25×10^6 and 2.55×10^6 , and angles of attack of -5, 0, +5 deg.

Model details, test conditions, phase-change paint photographs and reduced heat-transfer coefficients are presented in this report.

SECTION 2
MODELS AND APPARATUS

2.1 MODEL DESCRIPTION

Model drawings were provided ARO, Inc. by the appropriate contractors and fabrication of two sets of Stycast models was subcontracted to the Grumman Aircraft Corporation. Sketches showing the overall model dimensions of the orbiter and booster are presented in Figs. 1 and 2 respectively and a photograph of the mated configurations is shown in Fig. 3. Table 1 provides additional configuration description details but it should be pointed out that the models were cast as one smooth surface without moveable control surfaces. Presented in Table 2 are model coordinate measurements referenced to the axis system illustrated in Figs. 1 and 2.

Six-in.-diam hemispheres were cast from the same batch of Stycast used to cast the models so that the Stycast thermal properties could be determined from calibration runs on the hemispheres. Also Chromel-Alumel thermocouples were cast into the models approximately 1/8-in. from the surface to measure the initial model temperature.

2.2 FACILITY DESCRIPTION

Tunnel B is a continuous, closed-circuit, variable density wind tunnel with an axisymmetric contoured nozzle and a 50-in.-diam test section. The tunnel can be operated at a nominal Mach number of 6 or 8 at stagnation pressures from 20 to 300 and 50 to 900 psia, respectively, at stagnation temperatures up to 1350°R. The model may be injected into the tunnel for a test run and then retracted for model cooling or model changes without interrupting the tunnel flow.

SECTION 3 PROCEDURES

3.1 TEST TECHNIQUE

Prior to each run the models were cleaned and cooled with alcohol and then spray painted with Tempilaq. The models were installed on the model injection mechanism at the desired test attitude and relative position and the model temperature of each model was measured with a thermocouple probe or with the model-embedded thermocouples. During the course of the test many of the embedded thermocouples became inoperative and the probe temperature was generally used for the model initial temperature. The models were then injected into the airstream for approximately 20 seconds and during this time the model surface temperature rise produced isotherm melt lines. The progression of the melt lines was photographed with 70-mm sequenced cameras operating at two frames per second.

3.2 TEST CONDITIONS

Nominal test conditions are presented in the data summary sheets (Table 3). As mentioned in the foreword this test was part of a comprehensive Space Shuttle investigation and as a result the run numbers are not necessarily consecutive. The specific test conditions for each run (or group) are provided on the data tabulation sheets preceding each set of melt line photographs.

3.3 DATA REDUCTION

During each run the tunnel conditions and time of each picture were recorded on magnetic tape. The heat transfer coefficient for each picture was calculated from the semi-infinite slab transient heat conduction equation

$$\frac{T_{pc} - T_i}{T_{aw} - T_i} = 1 - e^{\beta^2} \operatorname{erfc} \beta$$

where $\beta = \frac{h\sqrt{\Delta t}}{\sqrt{\rho ck}}$ and $\sqrt{\rho ck} = 0.11 - 0.008 \sqrt{\Delta t}$

The equation for the thermal properties ($\sqrt{\rho ck}$) of Stycast was obtained by evaluation of a considerable amount of hemisphere calibration data and supplemented by VKF laboratory measurements.

Heat-transfer coefficients were calculated for assumed adiabatic wall temperatures of T_0 , $0.9T_0$, and $0.85T_0$ (see tabulated data sheets). The use of three values of T_{aw} provides an indication of the sensitivity of the heat-transfer coefficient (h) to the values of T_{aw} assumed. For the sake of consistency all heat-transfer coefficients shown on the photographs are based on $T_{aw} = T_0$.

All heat-transfer coefficients were non-dimensionalized by dividing by the stagnation point heat-transfer coefficient (Ref. 1) on a 0.013-ft radius sphere (a 1-ft radius sphere scaled down by the model scale).

SECTION 4

DATA PRESENTATION

The test results are presented as a series of four photographs obtained by a camera mounted in the side window (LS). The photographs

are grouped as follows:

<u>Model Surface</u>	<u>Re/ft</u>	<u>α</u>
Side view of mated configuration*	1.25×10^6	-5,0,5 (paint)
	2.55×10^6	" "
	"	" (oil flow)
	"	" (shadowgraph)

Preceding each set of photographs is a tabulated data sheet which lists the specific test conditions and the time of each picture with the corresponding heat-transfer parameters. In general, the booster and orbiter had slightly different initial temperatures and therefore the values of h/h_0 are slightly different. Of course, the heat-transfer parameters apply only to the melt lines of the corresponding picture. Body coordinates of the melt-lines may be obtained by use of the grid overlay provided with this report. Table 4, Page 44 presents a Summary Data Index of these data.

REFERENCE

1. Fay, J. A. and Riddell, F. R. "Theory of Stagnation Point Heat Transfer in Dissociated Air." Journal of the Aeronautical Sciences, Vol. 25, 1958, pp. 73-85.

*The corresponding data for the orbiter and booster alone (non-interference) are presented in Volume II.

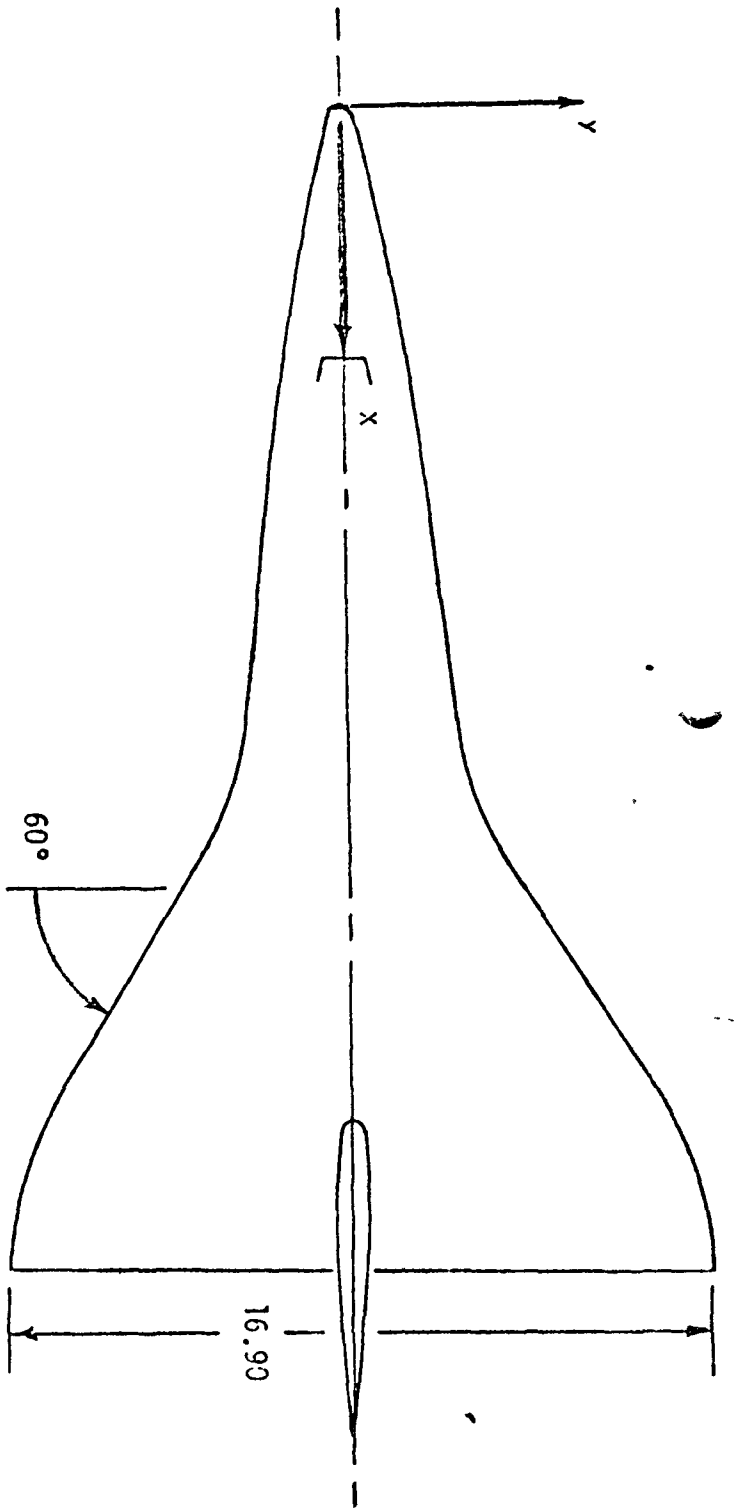

All Dimensions in Inches
 Model Scale ~ 0.013

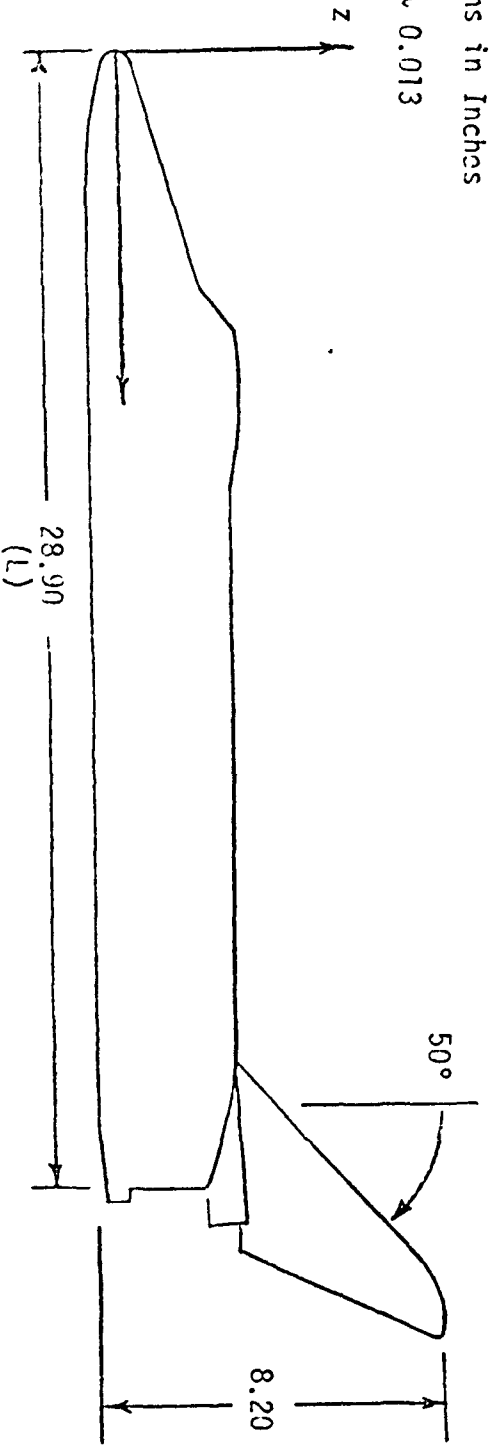
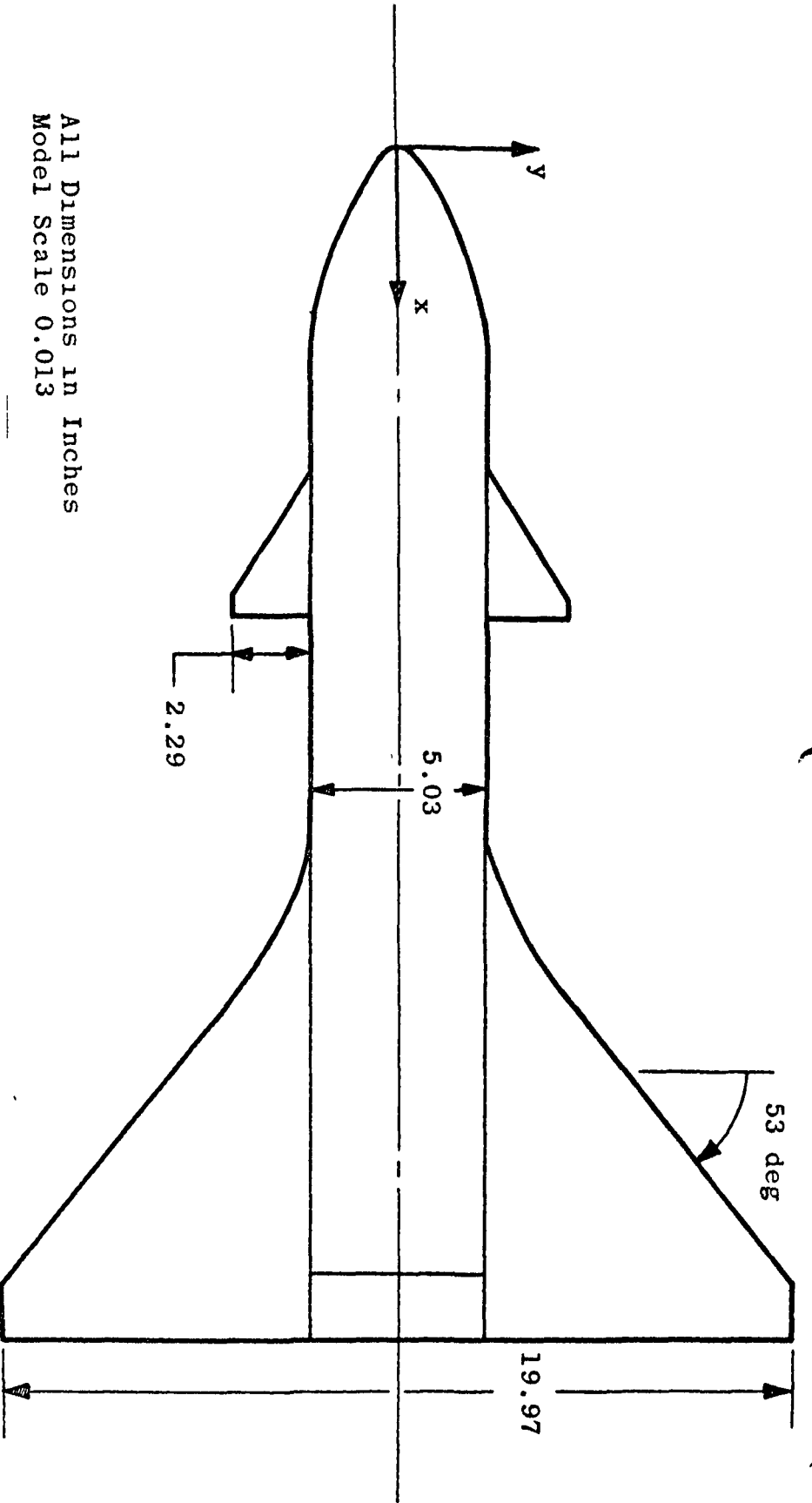

FIG. 1 North American Rockwell Pallet Wing Orbiter Model Sketch



All Dimensions in Inches
 Model Scale 0.013

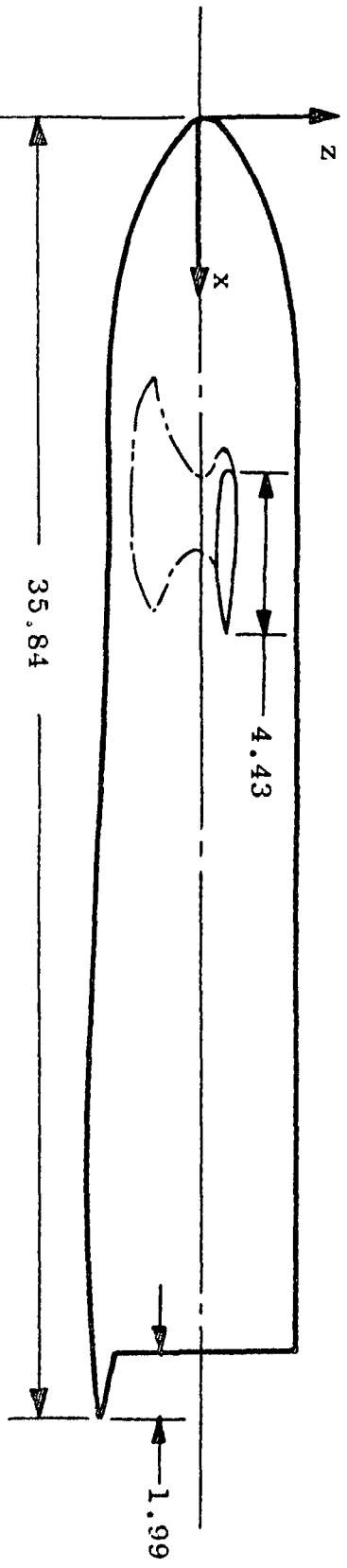

Fig. 2 General Dynamics - Convair Booster (GDC-B)

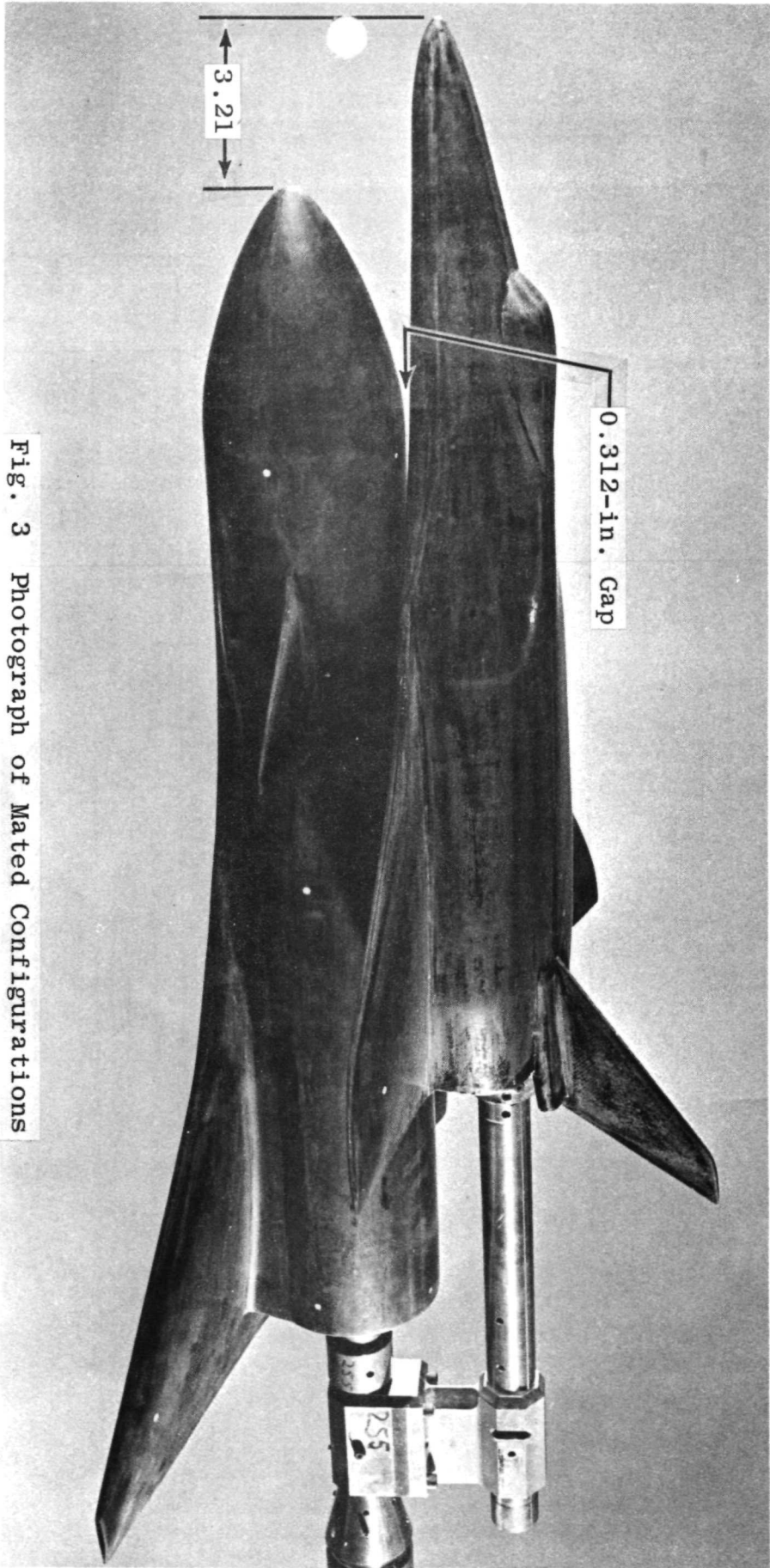

Fig. 3 Photograph of Mated Configurations

Table 1

Configuration Description Details

MODEL COMPONENT: BODY - B6

GENERAL DESCRIPTION: Basic delta wing fuselage as per NR lines drawing

9992-161B, Fuselage reference plane is located at water plane 400.00 in.

Model Scale = 0.013

DRAWING NUMBER: Lines Drawing 9992-161B

<u>DIMENSIONS:</u>	<u>FULL-SCALE</u>	<u>MODEL SCALE</u>
Length	<u>2223.00</u>	<u>28.89</u>
Max. Width	<u>495.80</u>	<u>6.445</u>
Max. Depth	<u>263.00</u>	<u>3.419</u>
Fineness Ratio	<u>6.019</u>	<u>6.019</u>
Area		
Max. Cross-Sectional	<u>743.95</u>	<u>0.1257</u>
Planform	<u>DNA</u>	<u>DNA</u>
Wetted	<u>DNA</u>	<u>DNA</u>
Base	<u>DNA</u>	<u>DNA</u>

Table 1 Continued

MODEL COMPONENT: Orbiter Wing DetailsGENERAL DESCRIPTION: Delta wing with -5° twist and rounded wing tips. Wing blended into body. Follows NR lines 9992-161B. Used with Body B6.Model Scale = 0.013DRAWING NUMBER: _____DIMENSIONS:FULL-SCALEMODEL SCALETOTAL DATA

Area, ft ²		
Planform	6511.00	1.1003
Wetted	-	-
Span (equivalent), in.	1272.38	16.540
Aspect Ratio	1.714	1.714
Rate of Taper	1.719	1.719
Taper Ratio	0.144	0.144
Dihedral Angle, degrees	7.000	7.000
Incidence Angle, degrees	0.000	0.000
Aerodynamic Twist, degrees (about T.E.)	-5.000	-5.000
Toe-In Angle		
Cant Angle		
Sweep Back Angles, degrees		
Leading Edge	59.808	59.808
Trailing Edge	0.000	0.000
0.25 Element Line	52.197	52.197
Chords: in.		
Root (Wing Sta. 0.0)	1287.70	16.739
Tip, (equivalent)(W.S. 640.97)	186.00	2.418
MAC (W.S. 240.62)	874.10	11.363
Fus. Sta. of .25 MAC	1793.32	23.313
W.P. of .25 MAC	280.73	3.650
Airfoil Section		
Root (W.S. 249.75)	NACA 0009-64	
Tip (W.S. 561.85)	NACA 0012-64	

EXPOSED DATA

Area, ft ²	3023.00	0.5108
Span, (equivalent), in.	810.61	10.538
Aspect Ratio	1.498	1.498
Taper Ratio	0.209	0.209
Chords, in.		
Root (Equiv.)(W.S. 232.62)	887.85	11.543
Tip (Equiv.)(W.S. 640.97)	186.00	2.418
MAC (W.S. 392.31)	613.33	7.973
Fus. Sta. of .25 MAC	1988.65	25.855
W.P. of .25 MAC	299.22	3.889

Table 1 - continued

Orbiter Elevon Details

MODEL COMPONENT: Elevon - E₁₁ (Data for one of two sides)

GENERAL DESCRIPTION: Constant chord elevon located on Delta Wing - W₂₁

Model Scale = 0.013

DRAWING NUMBER: _____

DIMENSIONS:

	<u>FULL-SCALE</u>	<u>MODEL SCALE</u>
Area (true), ft ²	<u>423.09</u>	<u>0.0715</u>
Span (equivalent), in.	<u>417.30</u>	<u>5.425</u>
Inb'd equivalent chord, in. (W.S. 237.48)	<u>146.00</u>	<u>1.893</u>
Outb'd equivalent chord, in. (W.S. 654.78)	<u>146.00</u>	<u>1.893</u>
Ratio movable surface chord/ total surface chord		
At Inb'd equiv. chord	<u>0.166</u>	<u>0.166</u>
At Outb'd equiv. chord	<u>0.900</u>	<u>0.900</u>
Sweep Back Angles, degrees		
Leading Edge	<u>0.000</u>	<u>0.000</u>
Tailing Edge	<u>0.000</u>	<u>0.000</u>
Hingeline	<u>0.000</u>	<u>0.000</u>
Area Moment (Normal to hinge line), ft ³ (Product of area and mean chord)	<u>5144.00</u>	<u>0.0113</u>

MODEL COMPONENT: Vertical Tail - V27

GENERAL DESCRIPTION: Centerline vertical tail on delta wing configuration.

The total data includes the void area listed below. Used with Body-B6.

Follows NR lines 9992-161B.

Model Scale = 0.009

DRAWING NUMBER: _____

DIMENSIONS:

FULL-SCALE

MODEL SCALE

TOTAL DATA

Area, ft ²		
Planform	626.03	0.1058
Wetted		
Span (equivalent), in.	361.06	4.694
Aspect Ratio	1.446	1.446
Rate of Taper	0.718	0.718
Taper Ratio	0.316	0.316
Dihedral Angle, degrees	-	-
Incidence Angle, degrees	-	-
Aerodynamic Twist, degrees	-	-
Toe-In Angle	0.000	0.000
Cant Angle	0.000	0.000
Sweep Back Angles, degrees		
Leading Edge	50.003	50.003
Trailing Edge	25.352	25.352
0.25 Element Line	45.352	45.352
Chords: in.		
Root (W.P. 511.62)	379.31	4.931
Tip, (equivalent) (W.P. 872.67)	120.05	1.560
MAC, inches	272.11	3.537
Fus. Sta. of .25 MAC	2422.61	31.493
W.P. of .25 MAC	660.90	8.591
Airfoil Section		
(W.P. 500.44)	NACA 0012-64	
(W.P. 878.00)	NACA 0009-64	

EXPOSED DATA

Area	_____	_____
Span, (equivalent)	_____	_____
Aspect Ratio	_____	_____
Taper Ratio	_____	_____
Chords		
Root	_____	_____
Tip	_____	_____
MAC	_____	_____
Fus. Sta. of .25 MAC	_____	_____
W.P. of .25 MAC	_____	_____

Table 1 continued

Orbital Maneuvering System Shroud Details

MODEL COMPONENT: Orbital Maneuvering System Shroud - Z₂

GENERAL DESCRIPTION: Fairing over orbital maneuvering system. Located on aft upper fuselage mold line.

Model Scale = 0.013

DRAWING NUMBER: _____

<u>DIMENSIONS:</u>	<u>FULL-SCALE</u>	<u>MODEL SCALE</u>
Length (along upper surface), in.	<u>359.31</u>	<u>4.671</u>
Sta. of Leading Edge, in.	<u>2163.33</u>	<u>28.123</u>
Sta. of Trailing Edge, in.	<u>2523.56</u>	<u>32.806</u>
Pitch Angle (T.E. Up), deg.	<u>3.181</u>	<u>4.594</u>
Area		
Max. Cross-Sectional	_____	_____
Planform	_____	_____
Wetted	_____	_____
Base	_____	_____

Table 1 continued
Orbiter Drag Brake Details

MODEL COMPONENT: Drag Brake - J4 (Data for one of two sides)

GENERAL DESCRIPTION: Drag Brake - J4 is the deflectable side panels of
delta wing vertical tail V27 hinged at the 60% element line and
extending to the trailing edge

Model Scale = 0.013

DRAWING NUMBER:

(All dimensions are in the drag brake reference plane)

<u>DIMENSIONS:</u>	<u>FULL-SCALE</u>	<u>MODEL SCALE</u>
Area, ft ²	<u>242.39</u>	<u>0.04095</u>
Span (equivalent), in.	<u>355.61</u>	<u>4.623</u>
Inb'd equivalent chord, in. (W.P. 520.18)	<u>149.22</u>	<u>1.939</u>
Outb'd equivalent chord, in. (W.P. 875.79)	<u>47.08</u>	<u>0.612</u>
Ratio movable surface chord/ total surface chord		
At Inb'd equiv. chord	<u>-</u>	<u>-</u>
At Outb'd equiv. chord	<u>-</u>	<u>-</u>
Sweep Back Angles, degrees		
Leading Edge	<u>37.273</u>	<u>37.273</u>
Tailing Edge	<u>25.352</u>	<u>25.352</u>
Hingeline	<u>37.273</u>	<u>37.273</u>
Area Moment (Normal to hinge line), ft ³ (Produce of area and mean chord)	<u>1921.27</u>	<u>0.00422</u>
Buttock Plane of Hingeline, in.	<u>3.44</u>	<u>0.045</u>

Table 1 continued

MODEL COMPONENT: BODY - B24

GENERAL DESCRIPTION: Basic Fuselage for the B-15B-2 Booster Configuration

DRAWING NUMBER: WT-71-105129

<u>DIMENSIONS:</u>	<u>FULL-SCALE</u>	<u>MODEL SCALE</u>
Length	<u>2757 in.</u>	<u>35.84 in.</u>
Max. Width	<u>387 in.</u>	<u>5.03 in.</u>
Max. Depth	<u>453 in.</u>	<u>5.89 in.</u>
Fineness Ratio	<u>6.08</u>	<u>6.08</u>
Area		
Max. Cross-Sectional	<u>183837 in²</u>	<u>31.07 in²</u>
Planform	<u>1010612 in²</u>	<u>170.79 in²</u>
Wetted	<u> </u>	<u> </u>
Base	<u>159510 in²</u>	<u>25.43 in²</u>

Table 1 continued

MODEL COMPONENT: Canard C4

GENERAL DESCRIPTION: Basic Canard for B-15B-2 Booster Configuration

DRAWING NUMBER: WT-71-105129

<u>DIMENSIONS:</u>	<u>FULL-SCALE</u>	<u>MODEL SCALE</u>
Area	<u>66286 in²</u>	<u>11.20 in²</u>
Span (equivalent)	<u>352 in.</u>	<u>4.58 in.</u>
Inb'd equivalent chord	<u>341 in.</u>	<u>4.43 in.</u>
Outh'd equivalent chord	<u>36 in.</u>	<u>0.468 in.</u>
Ratio Elevator chord/horizontal tail chord		
At Inb'd equiv. chord	<u> </u>	<u> </u>
At Outh'd equiv. chord	<u> </u>	<u> </u>
Sweep Back Angles, degrees		
Leading Edge	<u>60</u>	<u>60</u>
Tailing Edge	<u>0</u>	<u>0</u>
Hingeline	<u> </u>	<u> </u>
Area Moment (Normal to hinge line)	<u> </u>	<u> </u>

Table 1 continued

MODEL COMPONENT: Wing - W₁₅

GENERAL DESCRIPTION: Basic Wing for the B-15B-2 Booster Configuration -

C_L Design = 0.215

DRAWING NUMBER: WT-71-105125

DIMENSIONS:

FULL-SCALE

MODEL SCALE

TOTAL DATA

Area

Planform

1241959 in²

209.89 in²

Wetted

Span (equivalent)

1739 in.

22.61 in.

Aspect Ratio

2.436

2.436

Rate of Taper

Taper Ratio

0.106

0.106

Diehedral Angle, degrees

3 (TE)

3 (TE)

Incidence Angle, degrees

2

2

Aerodynamic Twist, degrees

0

0

Toe-In Angle

Cant Angle

Sweep Back Angles, degrees

Leading Edge

53

53

Trailing Edge

0

0

0.25 Element Line

44.85

44.85

Chords:

Root (Wing Sta. 0.0)

1291 in.

16.78 in.

Tip, (equivalent)

137 in.

1.77 in.

MAC, inches

869.4 in.

11.29 in.

Fus. Sta. of .25 MAC

W.P. of .25 MAC

Airfoil Section

Root

Tip

NACA-0010-64 (Mod)

NACA-0010-63 (Mod)

EXPOSED DATA

Area

812980 in²

137.39 in²

Span, (equivalent)

1373 in.

17.85 in.

Aspect Ratio

2.25

2.25

Taper Ratio

0.1306

0.1306

Chords

Root

1048 in.

13.62 in.

Tip

137 in.

1.78 in.

MAC

709.1 in.

9.22 in.

Fus. Sta. of .25 MAC

W.P. of .25 MAC

Table 1 concluded

MODEL COMPONENT: Elevon

GENERAL DESCRIPTION: Basic Elevon for the W₁₅ Wing

DRAWING NUMBER: WT-71-105125

<u>DIMENSIONS:</u>	<u>FULL-SCALE</u>	<u>MODEL SCALE</u>
Area	<u>69178 in²</u>	<u>11.68 in²</u>
Span (equivalent)	<u>486 in.</u>	<u>6.31 in.</u>
Inb'd equivalent chord	<u>172 in.</u>	<u>2.23 in.</u>
Outb'd equivalent chord	<u>114 in.</u>	<u>1.48 in.</u>
Ratio Elevator chord/horizontal tail chord		
At Inb'd equiv. chord	<u>0.167</u>	<u>0.167</u>
At Outb'd equiv. chord	<u>0.294</u>	<u>0.294</u>
Sweep Back Angles, degrees		
Leading Edge	<u>6.73</u>	<u>6.73</u>
Tailing Edge	<u>0.0</u>	<u>0.0</u>
Hingeline	<u>6.73</u>	<u>6.73</u>
Area Moment (Normal to hinge line)	<u> </u>	<u> </u>

Table 2 Model Coordinates

AEDC/FORT/INC-1 WOLD AFB, TENNESSEE
 VON KARMAN GAS DYNAMICS FACILITY
 50 INCH HYPERSONIC TUNNEL 8
 VT11162

MODEL GEOMETRY - GDC TOP SURFACE - ALL DIMENSIONS IN INCHES - 9 MAY 1972

STA NO.	X	Y	Z	X	Y	Z	X	Y	Z	X	Y	Z	X	Y	Z
1	0	0	0												
2	.20	0	0	-.37	.14	0	-.30	.28	-.17	.38	-.01	.41	0	.41	.13
3	.40	0	0	-.56	.09	0	-.52	.22	-.40	.41	-.23	.53	-.01	.58	.13
4	.60	0	0	-.71	.18	0	-.69	.14	-.60	.38	-.45	.57	-.26	.68	.38
5	.80	0	0	-.84	.20	0	-.80	.29	-.68	.48	-.57	.61	-.32	.79	.84
6	1.00	0	0	-.95	.25	0	-.92	.29	-.79	.54	-.61	.75	-.29	.93	.96
7	1.50	0	0	1.23	.26	0	1.11	.26	1.00	.64	1.16	.28	1.20	0	1.24
8	2.00	0	0	1.46	.26	0	1.38	.26	1.38	.47	1.19	.84	1.21	-.39	1.42
9	2.50	0	0	1.65	.20	0	1.59	.20	1.59	.44	1.52	.67	1.33	1.00	1.30
10	3.00	0	0	1.83	.24	0	1.82	.24	1.75	.55	1.57	.96	1.41	1.19	1.53
11	4.00	0	0	2.15	.14	0	2.12	.14	2.05	.68	1.87	1.09	1.61	1.46	1.77
12	5.00	0	0	2.33	.30	0	2.32	.30	2.17	.93	1.95	1.35	1.76	1.60	1.92
127	2.33	0	0	2.33	2.41	0	2.41	2.41	2.41	2.41	2.41	2.41	2.41	2.41	2.41

REEDLAND, INC. - J. T. OLD AFS, TENNESSEE
 VON KARPAN GAS DYNAMICS FACILITY
 50 INCH HYPERSONIC TUNNEL B
 V71162

MODEL GEOMETRY - GDC TOP SURFACE - ALL DIMENSIONS IN INCHES - 9 MAY 1972

20

STA NO.	X	Y	Z	X	Y	Z	X	Y	Z	X	Y	Z	X	Y	Z	X	Y	Z
13	6.00	0	-2.42	.28	-2.37	.63	-2.24	1.04	-1.91	1.59	-1.38	2.08	-.60	2.44	0	-.01	2.52	
144	0	2.52	.56	2.44	1.22	2.17	1.78	1.71	2.22	1.04	2.40	.44	2.43	0				
14	7.00	0	-2.43	0	-2.37	.61	-2.25	1.01	-1.95	1.54	-1.45	2.05	-.68	2.43	0	-.01	2.54	
159	0	2.53	.66	2.43	1.42	2.06	2.04	1.39	2.36	.63	2.43	0						
15	6.00	0	-2.42	.34	-2.32	.83	-2.03	1.44	-1.49	2.03	-.81	2.40	-.01	2.55	0	2.54		
173	0	2.39	1.62	1.89	2.15	1.21	2.37	.55	2.43	0								
16	9.00	0	-2.42	.36	-2.40	.66	-2.34	.80	-2.22	1.12	-1.83	1.72	-1.26	2.20	-.62	2.47		
186	0	2.56	0	2.56	.71	2.44	1.38	2.11	1.95	1.53	2.24	1.00	2.33	.79	2.37	2.70		
17	9.50	.62	-2.41	.80	-2.34	.87	-2.29	.95	-2.16	1.23	-1.88	1.67	-1.59	1.96	-1.12	2.29		
205	0	2.49	-.01	2.57	.78	2.44	.65	.69	2.45	1.47	2.04	1.92	1.59	2.19	1.12	2.30	.90	
18	10.50	.71	-2.46	.88	-2.73	.95	-2.51	1.01	-2.34	1.03	-2.31	1.04	-2.30	1.06	-2.23	1.15		
224	0	1.70	-1.22	2.23	-.51	2.52	-.01	2.57	0	2.57	.67	2.46	1.46	2.04	1.86	1.66		
19	11.50	.77	-3.45	.73	-3.45	.84	-3.36	.90	-3.09	.97	-2.66	1.06	-2.37	1.09	-2.29	1.10		
19	0	1.18	-2.13	1.36	-1.89	1.73	-1.32	2.23	-.50	2.57	-.01	2.63	0	2.63	.71	2.51		
20	12.50	.75	-4.05	.82	-3.93	.87	-3.72	.92	-3.30	.99	-2.75	1.03	-2.37	1.04	-2.28	1.07		
274	0	1.08	-2.11	1.41	-1.78	1.84	-1.30	2.25	-.51	2.58	-.01	2.64	0	2.64	.59	2.55		
21	12.65	.76	-4.67	.82	-4.55	.84	-4.25	.86	-3.56	.87	-2.90	.88	-2.44	.89	-2.38	.90		
302	0	2.33	1.38	2.19	2.02	1.51	2.25	1.04	2.35	.86	2.43	.85	2.83	.85	3.47	.85		
22	14.07	.80	-4.62	.81	-4.39	.82	-4.04	.82	-3.64	.82	-3.24	.82	-2.75	.83	-2.45	.83		
330	0	2.55	1.28	2.26	1.83	1.78	2.20	1.18	2.32	.84	2.38	.80	2.51	.79	3.01	.79		

AERONAUTICS WOLD AFBS, TENNESSEE
 VON KARMAN GA. DYNAMICS FACILITY
 50 INCH HYPERSONIC TUNNEL B
 Y11162

MODEL GEOMETRY - 60C TOP SURFACE - ALL DIMENSIONS IN INCHES - 9 MAY 1972

STA NO.	X	Z	Y	Z	Y	Z	Y	Z	Y	Z	Y	Z	Y	Z	Y	Z	Y	Z	
23	15.00																		
357	-2.44	0	2.66	0.05	-2.43	0.31	-2.39	0.64	-2.28	1.06	-2.01	1.59	-1.38	2.23	-0.67	2.57	-0.01	2.66	
24	16.00																		
372	-2.42	0	2.63	0.57	-2.40	0.57	-2.30	0.92	-1.96	1.66	-1.45	2.12	-1.07	2.36	-0.58	2.55	-0.01	2.63	
25	17.00																		
386	-2.42	0	2.63	0.25	-2.41	0.25	-2.38	0.56	-2.34	0.79	-2.24	1.09	-1.85	1.76	-1.25	2.27	-0.66	2.53	
26	18.00																		
402	-2.43	0	2.64	0.72	-2.42	0.23	-2.38	0.62	-2.15	1.30	-1.76	1.87	-1.27	2.27	-0.66	2.34	-0.01	2.64	
27	19.00																		
417	-2.42	0	2.58	0.01	-2.41	0.22	-2.40	0.42	-2.35	0.75	-2.27	1.00	-2.13	1.33	-1.87	1.74	-1.38	2.20	
28	20.00																		
434	-2.41	0.19	2.51	0.17	-2.41	0.19	-2.40	0.42	-2.37	0.65	-2.31	0.88	-2.17	1.26	-1.86	1.77	-1.28	2.27	
29	21.00																		
451	-2.50	0.53	2.52	0.19	-2.50	0.29	-2.49	0.21	-2.48	0.25	-2.45	0.21	-2.42	0.24	-2.42	0.24	-2.42	0.24	-1.94
30	22.00																		
477	-2.45	0.26	2.67	0.26	-2.45	0.26	-2.44	0.26	-2.43	0.26	-2.42	0.26	-2.41	0.26	-2.40	0.26	-2.39	0.26	-2.38
31	23.00																		
507	-3.32	0.17	2.68	0.17	-3.32	0.17	-3.28	0.15	-3.24	0.15	-3.20	0.15	-3.17	0.15	-3.14	0.15	-3.11	0.15	-3.08
32	24.00																		
540	-3.83	0.15	2.79	0.15	-3.83	0.15	-3.79	0.15	-3.75	0.15	-3.71	0.15	-3.67	0.15	-3.63	0.15	-3.59	0.15	-3.55

6.00 -1.75 6.75 -1.76 7.52 -1.77 8.28 -1.81 8.84 -1.93 9.05 -2.01 9.11 -2.06 9.14 -2.11

RECORDERING - OLD AP31 TENNESSEE
 VON KARMAN GAS DYNAMICS FACILITY
 50 INCH HYPERSONIC TUNNEL B
 V11162

MODEL GEOMETRY - GDC TOP SURFACE - ALL DIMENSIONS IN INCHES - 9 MAY 1972

STA NO. POINT NO. X Y Z X Y Z X Y Z X Y Z X Y Z X Y Z

40
 888
 32.00
 -9.73 -2.12 -9.68 -2.06 -9.56 -1.98 -9.38 -1.92 -8.88 -1.83 -7.63 -1.79 -5.91 -1.82 -4.67 -1.87
 -3.49 -1.93 -2.77 -1.96 -2.61 -1.96 -2.53 -1.96 -2.48 -1.94 -2.43 -1.90 -2.42 -1.16 -2.42 0
 -2.41 .39 -2.37 .63 -2.31 .89 -2.15 1.31 -1.82 1.81 -1.46 2.16 -.95 2.46 2.38 2.62
 -.01 2.68 0 2.68 -.01 2.68 .88 2.52 1.37 2.27 1.85 1.86 2.21 1.31 2.38 .84
 2.45 .44 2.46 .24 2.47 -1.88 2.47 0 2.54 -1.92 2.64 -1.95 3.00 -1.94 3.83 -1.90
 4.72 -1.87 5.25 -1.85 5.62 -1.84 6.00 -1.83 6.90 -1.81 7.84 -1.80 8.78 -1.82 9.30 -1.88
 9.62 -1.95 9.78 -2.01 9.86 -2.05 9.90 -2.11

41
 940
 33.00
 -10.44 -2.11 -10.43 -2.06 -10.30 -1.99 -10.04 -1.92 -9.56 -1.85 -8.66 -1.83 -7.64 -1.85 -6.81 -1.88
 -6.44 -1.90 -5.60 -1.92 -4.72 -1.99 -3.75 -2.05 -2.40 0 -2.37 -2.09 -2.58 -2.11 -2.51 -2.10 -2.67 -2.09
 -2.42 -2.06 -2.40 2.27 -2.40 2.27 -2.40 2.67 .54 2.61 .57 -2.20 1.16 -1.84 1.76 -1.38 2.20
 -.83 2.50 -3.36 2.63 -.01 2.67 2.48 -2.03 2.48 0 2.56 -2.07 2.68 -2.09 2.89 -2.09 3.54 -2.06
 2.45 .55 2.47 .27 2.48 -1.95 2.48 -1.94 6.61 -1.92 7.40 -1.89 8.35 -1.86 9.14 -1.85
 4.39 -2.01 5.38 -1.97 5.81 -1.95 6.00 -2.05 10.62 -2.08 10.65 -2.12
 9.87 -1.89 10.25 -1.95 10.44 -2.00 10.56 -2.05 10.62 -2.08 10.65 -2.12

42
 994
 33.65
 -10.94 -2.10 -10.92 -2.07 -10.87 -2.03 -10.78 -2.00 -10.61 -1.94 -10.37 -1.90 -10.01 -1.87 -9.38 -1.85
 -8.59 -1.88 -7.59 -1.92 -6.64 -1.96 -6.00 -2.01 -5.54 -2.03 -4.95 -2.07 -4.15 -2.12 -3.37 -2.17
 -2.65 -2.21 -2.50 2.02 -1.05 2.38 -2.42 2.16 -.01 2.66 0 -2.40 -2.23 -2.38 2.46 2.32 .80
 -2.08 1.41 -1.58 2.02 -1.05 2.38 -2.42 2.16 -.01 2.66 0 -2.40 -2.23 -2.38 2.46 2.32 .80
 2.16 1.42 2.42 .76 2.49 -2.10 2.49 0 2.49 .24 2.57 -2.17 2.71 -2.18 2.92 -2.18
 3.80 -2.14 4.92 -2.07 5.77 -2.03 6.00 -2.02 7.10 -1.97 8.01 -1.93 9.08 -1.90 10.04 -1.90
 10.62 -1.95 10.91 -2.02 11.04 -2.07 11.10 -2.12

43
 1070
 34.70
 -11.08 -2.09 -11.03 -2.04 -10.94 -2.00 -10.85 -1.97 -10.66 -1.93 -10.38 -1.89 -10.01 -1.86 -9.38 -1.85
 -7.55 -1.95 -5.59 -2.06 -3.99 -2.16 -2.76 -2.25 -1.70 -2.31 1.70 -2.29 2.32 -2.26 3.36 -2.21
 5.48 -2.09 7.05 -2.01 8.93 -1.92 10.42 -1.92 10.98 -1.99 11.15 -2.03 11.25 -2.07 11.26 -2.09
 -11.10 -1.93 -11.03 -1.92 -10.85 -1.92 -10.13 -1.92 -9.04 -1.97 -7.89 -2.04 -5.48 -2.19 -3.78 -2.32
 -2.29 -2.42 -1.43 -2.47 1.60 -2.44 2.20 -2.42 2.86 -2.38 4.11 -2.31 5.26 -2.23 6.41 -2.16
 7.36 -2.11 8.48 -2.05 9.66 -1.99 10.47 -1.95 10.94 -1.95 11.16 -1.96 11.24 -1.97

45
 1093
 35.55
 -11.03 -2.00 -10.94 -2.00 -10.62 -2.02 -9.52 -2.10 -7.80 -2.20 -5.79 -2.34 -4.26 -2.45 -2.51 -2.57
 -1.47 -2.63 1.80 -2.60 2.28 -2.58 3.33 -2.52 4.64 -2.44 6.07 -2.35 7.54 -2.26 8.73 -2.18
 9.66 -2.13 10.47 -2.09 10.98 -2.06 11.20 -2.05

11
 12
 13
 14
 15
 16
 17
 18
 19
 20

REDGAR, INC. VOLVO AF'S, TENNESSEE
 VON KARMAN GAS DYNAMICS FACILITY
 50 INCH HYPERSONIC TUNNEL B
 V11162

MODEL GEOMETRY - GDC SIDE SURFACE - ALL DIMENSIONS IN INCHES - 9 MAY 1972

STA NO. POINT NO.	X	Y	Z	X	Y	Z	X	Y	Z	X	Y	Z	X	Y	Z	X	Y	Z	
1	0	0	0																
2	.20	0	-.44	.12	-.39	.21	-.34	.33	-.22	.39	0	.39	.01	.35	.19	.27	.30	.30	
3	.40	0	.41	0	.44														
4	.60	0	-.61	.12	-.55	.24	-.53	.42	-.35	.51	-.20	.54	0	.54	.01	.51	.20	.20	
5	.80	0	.37	.23	.53	0	.60												
6	1.00	0	.60	.29	-.64	.48	-.48	.63	-.26	.67	0	.67	.01	.63	.26	.55	.42	.42	
7	1.20	0	.55	.26	.64	0	.73												
8	.80	0	.84	.35	-.75	.62	-.53	.75	-.31	.80	0	.81	.01	.76	.30	.68	.46	.46	
9	1.00	0	.62	.26	.76	0	.86												
10	1.20	0	.99	.46	-.83	.72	-.60	.87	-.32	.92	0	.93	.01	.88	.32	.78	.52	.52	
11	1.40	0	.69	.40	.86	.20	.89	0	1.00										
12	1.60	0	-.24	.52	-1.10	.83	-.88	1.08	-.53	1.19	0	1.20	.01	1.12	.43	.96	.73	.73	
13	1.80	0	.74	.43	1.11	.13	1.19	0	1.24										
14	2.00	0	-.47	.62	-1.33	1.03	-1.02	1.31	-.60	1.43	0	1.43	.01	1.39	.33	1.29	.63	.63	
15	2.20	0	.91	.78	1.22	.37	1.39	0	1.48										
16	2.40	0	-.70	.81	-1.44	1.24	-.96	1.54	-.57	1.63	0	1.63	.01	1.58	.40	1.48	.70	.70	
17	2.60	0	1.12	.74	1.50	.37	1.62	0	1.71										
18	2.80	0	-.87	.45	-1.81	.87	-1.64	1.41	-1.18	1.69	-.66	1.80	0	1.81	.01	1.73	.55	.55	
19	3.00	0	1.08	1.19	1.40	.70	1.67	.21	1.80										
20	3.20	0	-.12	.52	-2.06	1.11	-1.84	1.69	-1.32	2.04	-.60	2.12	0	2.12	.01	2.03	.63	.63	
21	3.40	0	1.20	1.34	1.67	.89	1.95	.34	2.12										
22	3.60	0	-.35	.55	-2.30	1.26	-1.99	1.86	-1.46	2.20	-.84	2.33	0	2.33	.01	2.25	.61	.61	
23	3.80	0	1.31	1.45	1.83	.72	2.24	.18	2.36										
24	4.00	0	-.48	.51	-2.43	1.08	-2.22	1.90	-1.58	2.34	-.73	2.43	0	2.43	.01	2.38	.45	.45	
25	4.20	0	1.10	1.59	1.87	.95	2.25	.53	2.39	.20	2.45	0	2.47						

REDSTAR, INC. OLD AFS, TENNESSEE
 VON KARPAN GAS DYNAMICS FACILITY
 50 INCH HYPERSONIC TUNNEL B
 VTL1162

MODEL GEOMETRY - GDC SIDE SURFACE - ALL DIMENSIONS IN INCHES - 9 MAY 1972

STA NO.	X	Z	Y	Z	Y	Z	Y	Z	Y	Z	Y	Z	Y	Z
POINT NO.	Y	Z	Y	Z	Y	Z	Y	Z	Y	Z	Y	Z	Y	Z
31	23.00													
572	0	-2.67	.25	-2.65	.74	-2.55	1.55	-2.07	2.09	-1.41	2.38	-1.53	2.40	0
	2.34	.35	2.26	.65	2.24	1.01	2.24	1.26	2.26	1.38	2.29	1.47	2.39	1.57
	2.99	1.79	3.19	1.97	3.26	2.11	3.26	2.24	3.19	2.37	2.99	2.50	2.48	2.70
	1.16	2.89	.66	2.93	.36	2.93	0	2.94					2.48	2.84
32	24.00													
0	0	-2.67	.63	-2.57	1.52	-2.09	2.10	-1.39	2.37	-1.60	2.40	0	2.40	.01
	2.27	.66	2.26	1.06	2.26	1.28	2.30	1.42	2.40	1.54	2.59	1.60	3.02	1.70
	3.00	1.96	3.78	2.15	3.77	2.21	3.69	2.34	3.46	2.45	3.03	2.62	2.59	2.75
	1.29	2.92	.49	2.95	0	2.97							2.59	2.75
33	25.00													
627	0	-2.67	.31	-2.65	.77	-2.52	1.43	-2.17	2.02	-1.54	2.36	-1.67	2.39	0
	2.30	.46	2.27	.65	2.27	1.01	2.29	1.25	2.37	1.43	2.58	1.54	3.11	1.61
	4.24	1.83	4.41	1.06	4.46	2.11	4.44	2.19	4.40	2.29	4.22	2.37	3.51	2.60
	1.64	2.94	1.10	2.97	.62	2.98	.29	2.99	0	2.99			3.51	2.60
34	26.00													
656	0	-2.69	.27	-2.66	.73	-2.56	1.49	-2.13	2.05	-1.49	2.37	-1.58	2.39	0
	2.33	.40	2.27	.62	2.27	.84	2.28	1.16	2.30	1.32	2.41	1.49	3.13	1.58
	3.84	1.64	4.57	1.73	4.56	1.83	5.14	1.96	5.19	2.10	5.17	2.20	5.05	2.30
	4.35	2.52	3.73	2.66	3.11	2.77	2.29	2.90	1.56	2.98	1.01	3.01	.37	3.03
35	27.00													
688	0	-2.69	.43	-2.64	1.28	-2.29	2.01	-1.56	2.37	-1.56	2.39	0	2.39	.01
	2.27	.65	2.27	.98	2.28	1.24	2.34	1.43	2.49	1.54	3.43	1.58	4.57	1.66
	5.76	1.86	5.91	1.97	5.96	2.09	5.93	2.20	5.81	2.29	5.52	2.38	4.81	2.54
	2.98	2.86	2.10	2.96	1.29	3.03	.85	3.05	.48	3.06	0	3.06		2.74
36	28.00													
718	0	-2.66	1.04	-2.61	1.72	-1.92	2.15	-1.31	2.37	-1.59	2.39	0	2.39	.01
	2.27	.60	2.27	.99	2.27	1.21	2.30	1.39	2.39	1.53	2.51	1.57	3.68	1.58
	5.47	1.72	6.29	1.78	6.55	1.88	6.30	2.00	6.71	2.09	6.71	2.17	6.42	2.24
	5.70	2.47	4.83	2.52	4.04	2.75	3.08	2.88	2.56	2.94	1.88	3.01	1.18	3.06
	.38	3.08	0	3.08										.70
37	29.00													
752	0	-2.69	.46	-2.63	1.37	-2.25	2.09	-1.43	2.36	-1.67	2.39	0	2.39	.01
	2.26	.73	2.27	1.07	2.28	1.34	2.34	1.51	2.52	1.62	2.88	1.63	3.68	1.66
	7.02	1.79	7.30	1.90	7.40	1.99	7.44	2.09	7.42	2.17	7.30	2.24	6.99	2.31
	4.89	2.66	3.79	2.81	3.03	2.91	1.72	3.03	1.37	3.08	1.09	3.08	.69	3.09
	0	3.09												.37
38	30.00													
785	0	-2.66	.92	-2.66	1.59	-2.03	2.05	-1.48	2.38	-1.50	2.39	0	2.39	.01
	2.26	.64	2.26	.92	2.27	1.14	2.28	1.43	2.32	1.55	2.40	1.65	2.52	1.70
	7.51	1.75	8.00	1.99	8.15	2.00	8.20	2.11	8.18	2.18	8.09	2.21	7.87	2.26
	6.58	2.47	5.38	2.53	4.26	2.78	3.59	2.84	3.09	2.90	2.58	2.95	2.07	3.00
	1.09	3.07	.55	3.08	0	3.10							2.07	3.00

AEUTCARD(INC.) RANDOL AFB, TENNESSEE
 VON KARMAN GA DYNAMICS FACILITY
 50 INCH HYPERSONIC TUNNEL B
 V11162

MODEL GEOMETRY - 60C SIDE SURFACE - ALL DIMENSIONS IN INCHES - 9 MAY 1972

STA NO.	X	Z	Y	Z	Y	Z	Y	Z	Y	Z	Y	Z	Y	Z	Y	Z	Y	Z	
39	31.00																		
020	0	-2.68	.38	-2.65	.93	-2.47	1.61	-2.03	2.11	-1.38	2.37	-1.56	2.39	0	2.38	-.01			
	2.33	.34	2.26	.64	2.26	1.00	2.27	1.36	2.28	1.50	2.33	1.66	2.50	1.79	8.37	1.80			
	8.61	1.86	8.42	1.94	8.91	2.03	8.92	2.10	8.91	2.14	8.84	2.17	8.57	2.23	7.88	2.32			
	6.98	2.45	5.94	2.58	5.01	2.68	4.36	2.75	4.13	2.78	3.92	2.80	3.57	2.84	3.26	2.86			
	2.82	2.90	2.33	2.95	1.76	2.99	1.35	3.02	.93	3.04	.55	3.06	.28	3.07	0	3.10			
40	32.00																		
60	0	-2.69	.51	-2.61	1.29	-2.27	1.93	-1.65	2.35	-.67	2.39	0	2.38	.01	2.34	-.28			
	2.26	.60	2.26	.89	2.26	1.20	2.27	1.47	2.28	1.65	2.31	1.74	2.32	1.78	8.71	1.79			
	9.15	1.83	9.52	1.94	9.62	2.01	9.65	2.10	9.61	2.15	9.48	2.16	8.91	2.22	7.99	2.34			
	6.90	2.47	5.81	2.57	4.75	2.67	3.75	2.75	3.23	2.81	2.69	2.85	1.76	2.93	1.06	2.97			
	1.69	2.87	3.01																
41	33.00																		
093	0	-2.69	.31	-2.65	.90	-2.47	1.56	-2.05	2.15	-1.25	2.36	-.53	2.38	0	2.38	-.01			
	2.36	.21	2.28	.53	2.26	.67	2.26	.93	2.26	1.23	2.26	1.54	2.27	1.70	2.29	1.81			
	9.66	1.82	9.97	1.86	10.19	1.92	10.33	1.98	10.39	2.08	10.35	2.14	10.15	2.15	9.24	2.20			
	8.15	2.33	7.33	2.41	6.76	2.47	6.42	2.50	5.36	2.58	4.46	2.65	3.11	2.75	1.96	2.85			
	1.69	2.87																	
42	33.62																		
926	0	-2.68	.38	-2.64	1.21	-2.31	1.98	-1.56	2.33	-.70	2.37	0	2.37	.01	2.35	-.24			
	2.26	.60	2.26	1.06	2.26	1.42	2.26	1.62	2.27	1.77	2.27	1.84	2.27	1.84	10.61	1.90			
	10.73	1.94	10.81	1.99	10.86	2.05	10.83	2.11	10.53	2.11	9.25	2.19	7.98	2.35	5.83	2.47			
	4.59	2.57	2.94	2.69	2.18	2.76	1.75	2.79											
43	33.90																		
954	9.69	1.84	10.57	1.85	10.93	1.90	11.04	1.94	11.11	2.01	11.12	2.08	10.96	2.08	9.53	2.16			
	7.67	2.33	5.78	2.47	4.21	2.56	3.48	2.63	2.53	2.70	1.83	2.75							
44	34.70																		
968	11.13	1.90	11.15	1.96	11.14	2.07	10.44	2.08	9.36	2.14	7.94	2.23	6.16	2.35	4.66	2.43			
	3.00	2.57	1.83	2.64															
45	35.60																		
978	11.14	1.95	11.14	1.97	10.54	1.99	9.24	2.07	7.30	2.19	4.05	2.40	2.55	2.49	1.84	2.53			

AEDCTAROTYMCJ) TOLC ARS, TENNESSEE
 VON KARMAN GAS DYNAMICS FACILITY
 50 INCH HYPERSONIC TUNNEL B
 V11162

MODEL GEOMETRY - NARROW BOTTOM SURFACE - ALL DIMENSIONS IN INCHES - 9 MAY 1972

STA NO. POINT NO.	X	Y	Z	X	Y	Z	X	Y	Z	X	Y	Z	X	Y	Z	X	Y	Z
1	0	0	0	0	0	0	0	0	0	0	0	0	0	0	0	0	0	0
2	.25	0	0	-.16	-.17	0	-.24	.17	-.16	.21	0	0	0	0	0	0	0	0
3	-.24	0	0	-.16	-.17	0	-.24	.17	-.16	.21	0	0	0	0	0	0	0	0
4	.50	0	0	-.26	-.23	0	-.34	.18	-.28	.31	0	0	0	0	0	0	0	0
5	-.34	0	0	-.26	-.23	0	-.34	.18	-.28	.31	0	0	0	0	0	0	0	0
6	.75	0	0	-.34	-.24	0	-.39	.10	-.42	.30	-.26	.38	0	0	0	0	0	0
7	-.42	0	0	-.34	-.24	0	-.39	.10	-.42	.30	-.26	.38	0	0	0	0	0	0
8	1.00	0	0	-.33	-.34	0	-.48	.26	-.38	.43	-.17	.45	0	0	0	0	0	0
9	-.49	0	0	-.33	-.34	0	-.48	.26	-.38	.43	-.17	.45	0	0	0	0	0	0
10	1.25	0	0	-.47	-.26	0	-.46	-.01	-.54	.21	-.48	.42	-.28	.52	0	0	0	0
11	-.56	0	0	-.47	-.26	0	-.46	-.01	-.54	.21	-.48	.42	-.28	.52	0	0	0	0
12	1.50	0	0	-.53	-.26	0	-.48	-.02	-.58	.23	-.51	.49	-.27	.58	0	0	0	0
13	-.61	0	0	-.53	-.26	0	-.48	-.02	-.58	.23	-.51	.49	-.27	.58	0	0	0	0
14	1.75	0	0	-.55	-.29	0	-.51	0	-.60	.26	-.53	.51	-.32	.59	-.16	.63	0	0
15	-.65	0	0	-.55	-.29	0	-.51	0	-.60	.26	-.53	.51	-.32	.59	-.16	.63	0	0
16	2.25	0	0	-.67	-.22	0	-.46	-.47	-.24	-.60	0	-.64	.36	-.54	.60	-.31	.69	-.12
17	-.74	0	0	-.67	-.22	0	-.46	-.47	-.24	-.60	0	-.64	.36	-.54	.60	-.31	.69	-.12
18	.74	0	0	-.67	-.22	0	-.46	-.47	-.24	-.60	0	-.64	.36	-.54	.60	-.31	.69	-.12
19	2.50	0	0	-.64	-.31	0	-.52	0	-.65	.38	-.54	.63	-.31	.76	0	0	0	0
20	-.75	0	0	-.64	-.31	0	-.52	0	-.65	.38	-.54	.63	-.31	.76	0	0	0	0
21	2.75	0	0	-.66	-.32	0	-.54	0	-.65	.38	-.56	.72	-.25	.81	-.01	0	0	0
22	-.79	0	0	-.66	-.32	0	-.54	0	-.65	.38	-.56	.72	-.25	.81	-.01	0	0	0
23	.79	0	0	-.66	-.32	0	-.54	0	-.65	.38	-.56	.72	-.25	.81	-.01	0	0	0
24	3.00	.18	0	-.80	-.15	0	-.45	-.27	-.63	0	-.67	.38	-.59	.64	-.39	.81	-.10	0
25	-.85	.18	0	-.80	-.15	0	-.45	-.27	-.63	0	-.67	.38	-.59	.64	-.39	.81	-.10	0
26	.86	.17	0	-.80	-.15	0	-.45	-.27	-.63	0	-.67	.38	-.59	.64	-.39	.81	-.10	0
27	3.25	.27	0	-.87	-.05	0	-.45	-.57	0	-.68	.39	-.60	.68	-.38	.84	-.09	0	0
28	-.89	.27	0	-.87	-.05	0	-.45	-.57	0	-.68	.39	-.60	.68	-.38	.84	-.09	0	0
29	.90	.23	0	-.87	-.05	0	-.45	-.57	0	-.68	.39	-.60	.68	-.38	.84	-.09	0	0
30	3.50	.14	0	-.86	-.22	0	-.56	-.33	-.76	0	-.82	.36	-.78	.67	-.59	.85	-.34	0
31	-.92	.14	0	-.86	-.22	0	-.56	-.33	-.76	0	-.82	.36	-.78	.67	-.59	.85	-.34	0
32	.94	-.12	0	-.86	-.22	0	-.56	-.33	-.76	0	-.82	.36	-.78	.67	-.59	.85	-.34	0
33	3.75	.30	0	-.93	-.02	0	-.75	-.53	0	-.66	.38	-.59	.76	-.34	.89	-.09	0	0
34	-.97	.30	0	-.93	-.02	0	-.75	-.53	0	-.66	.38	-.59	.76	-.34	.89	-.09	0	0
35	.98	.30	0	-.93	-.02	0	-.75	-.53	0	-.66	.38	-.59	.76	-.34	.89	-.09	0	0

AEUCTAROB INC. TROU AFS, TENNESSEE
 VON KARMAN GAS DYNAMICS FACILITY
 50 INCH HYPERSONIC TUNNEL B
 V11162

MODEL GEOMETRY - NARDNO BOTTOM SURFACE - ALL DIMENSIONS IN INCHES - 9 MAY 1972

STA NO.	X	Z	Y	Z	Y	Z	Y	Z	Y	Z	Y	Z
28	7.00											
231	-1.47	.46	-1.38	.07	-1.11	-.33	-.71	-.57	-.35	-.63	0	-.64
	1.12	-.32	1.34	0	1.45	.44						.38
												-.80
												-.55
29	7.25											
242	-1.51	.50	-1.44	.11	-1.25	-.21	-.97	-.46	-.70	-.58	-.33	-.63
	.64	-.61	1.07	-.40	1.32	-.11	1.44	.15	1.50	.50		.30
												-.64
30	7.50											
255	-1.53	.50	-1.48	.14	-1.27	-.21	-.58	-.46	-.62	-.60	-.27	-.63
	.78	-.57	1.21	-.29	1.42	.01	1.49	.22	1.53	.51		.37
												-.64
31	7.75											
268	-1.55	.50	-1.51	.14	-1.31	-.19	-1.02	-.45	-.62	-.60	-.28	-.63
	.69	-.60	1.14	-.38	1.46	.02	1.54	.26	1.57	.50		.32
												-.64
32	8.00											
281	-1.61	.50	-1.55	.17	-1.37	-.16	-1.12	-.41	-.82	-.56	-.50	-.62
	.32	-.63	.65	-.61	1.10	-.44	1.34	-.21	1.49	.01	1.57	.25
												1.61
												.50
33	8.25											
296	-1.65	.50	-1.59	.18	-1.43	-.13	-1.18	-.38	-.85	-.56	-.48	-.62
	.31	-.63	.72	-.61	1.18	-.40	1.49	-.04	1.60	.22	1.65	.51
												-.23
												-.63
34	8.50											
310	-1.65	.50	-1.61	.17	-1.40	-.20	-1.18	-.40	-.88	-.55	-.54	-.61
	.31	-.63	.68	-.61	1.08	-.48	1.46	-.16	1.59	.09	1.65	.29
												1.68
												.50
35	8.75											
225	-1.70	.63	-1.67	.25	-1.48	-.14	-1.21	-.40	-.84	-.57	-.42	-.62
	.80	-.60	1.24	-.39	1.58	-.01	1.67	.24	1.72	.61		-.01
												-.62
												.33
												-.63
36	9.00											
338	-1.74	.60	-1.70	.19	-1.50	-.17	-1.16	-.45	-.82	-.58	-.52	-.61
	.72	-.64	1.09	-.50	1.50	-.17	1.67	.10	1.73	.36	1.75	.60
												.34
												-.62
37	9.25											
352	-1.77	.60	-1.75	.26	-1.62	-.05	-1.40	-.30	-.91	-.69	-.78	-.59
	.28	-.62	.67	-.61	1.12	-.50	1.56	-.15	1.68	.06	1.75	.27
												1.79
												.60
38	9.50											
367	-1.80	.60	-1.79	.26	-1.65	-.05	-1.36	-.36	-1.06	-.52	-.72	-.60
	.32	-.62	.70	-.61	1.11	-.52	1.47	-.28	1.69	0	1.79	.28
												1.83
												.60
39	9.75											
382	-1.86	.60	-1.83	.25	-1.70	-.06	-1.48	-.31	-1.23	-.47	-.93	-.57
	0	-.62	.37	-.62	.72	-.61	1.07	-.54	1.39	-.36	1.66	-.07
												1.81
												.30
												1.85
												.60

AEDCTAROTING) TOLD AFS, TENNESSEE
 VON KARMAN GAS DYNAMICS FACILITY
 50 INCH HYPERSONIC TUNNEL B
 VT1162

MODEL GEOMETRY - NARROW BOTTOM SURFACE - ALL DIMENSIONS IN INCHES - 9 MAY 1972

STA NO.	X	Z	Y	Z	Y	Z	Y	Z	Y	Z	Y	Z	Y	Z	Y	Z	Y	Z	
40	10.00																		
398	-1.89	.60	-1.86	.21	-1.66	-.16	-1.30	-.44	-.93	-.57	-.52	-.61	-.25	-.61	0	-.62			
	.25	-.62	.63	-.61	1.01	-.57	1.45	-.34	1.76	.01	1.87	.35	1.89	.60					
41	10.25																		
413	-1.94	.60	-1.91	.23	-1.75	-.12	-1.47	-.37	-1.15	-.53	-.73	-.60	-.31	-.61	0	-.62			
	.37	-.62	.80	-.61	1.27	-.48	1.67	-.19	1.87	.18	1.91	.38	1.93	.60					
42	10.50																		
428	-1.98	.60	-1.95	.22	-1.80	-.11	-1.54	-.35	-1.22	-.51	-.89	-.59	-.55	-.60	-.25	-.61			
	0	-.61	.41	-.62	.75	-.61	1.11	-.55	1.48	-.38	1.76	-.12	1.91	.16	1.95	.35			
	1.96	.60																	
43	10.75																		
445	-2.02	.60	-2.01	.26	-1.85	-.10	-1.51	-.39	-1.13	-.54	-.76	-.60	-.40	-.61	-.06	-.61			
	.29	-.62	.67	-.61	1.11	-.56	1.52	-.38	1.82	-.10	1.95	.14	1.99	.36	2.01	.60			
44	11.00																		
461	-2.07	.60	-2.05	.23	-1.92	-.07	-1.67	-.31	-1.34	-.49	-.94	-.58	-.51	-.61	-.23	-.61			
	0	-.62	.36	-.62	.70	-.61	1.07	-.58	1.44	-.46	1.71	-.28	1.93	0	2.01	.22			
	2.05	.60																	
45	11.25																		
478	-2.11	.50	-2.09	.20	-1.96	-.08	-1.71	-.33	-1.40	-.49	-.96	-.58	-.55	-.60	-.26	-.61			
	0	-.62	.36	-.62	.82	-.61	1.29	-.53	1.71	-.32	1.93	-.08	2.04	.15	2.07	.35			
	2.09	.50																	
46	11.50																		
5	-2.12	.30	-2.06	.02	-1.88	-.23	-1.61	-.41	-1.28	-.53	-.93	-.59	-.63	-.60	-.40	-.61			
	-.19	-.61	0	-.62	.29	-.62	.73	-.61	1.12	-.58	1.52	-.46	1.89	-.21	2.07	.08			
	2.11	.30																	
47	12.00																		
512	-2.21	.40	-2.19	.09	-2.04	-.16	-1.81	-.36	-1.47	-.50	-1.03	-.58	-.56	-.60	-.28	-.61			
	0	-.62	.29	-.62	.69	-.61	1.07	-.60	1.46	-.52	1.86	-.33	2.13	-.03	2.18	.18			
	2.20	.40																	
48	12.25																		
529	-2.25	.30	-2.20	0	-2.02	-.24	-1.75	-.41	-1.42	-.53	-1.09	-.58	-.75	-.60	-.49	-.61			
	-.25	-.61	0	-.62	.28	-.62	.65	-.61	1.11	-.60	1.56	-.50	1.92	-.33	2.18	-.01			
	2.23	.30																	
49	12.50																		
546	-2.27	.20	-2.19	-.10	-1.94	-.33	-1.62	-.48	-1.25	-.56	-.80	-.60	-.49	-.60	-.25	-.61			
	0	-.61	.28	-.62	.61	-.61	1.00	-.60	1.47	-.54	1.82	-.42	2.12	-.20	2.23	0			
	2.27	.20																	
50	12.75																		
563	-2.32	.20	-2.24	-.11	-1.99	-.35	-1.67	-.48	-1.30	-.56	-.91	-.60	-.64	-.60	-.41	-.61			
	0	-.62	.36	-.62	.86	-.61	1.35	-.57	1.78	-.46	2.09	-.28	2.28	.01	2.31	.20			

ACCELERATION WOLD AFSS, TENNESSEE
 VON KARMAN GAS DYNAMICS FACILITY
 50 INCH HYPERSONIC TUNNEL B
 V71162

MODEL GEOMETRY - NARROW BOTTOM SURFACE - ALL DIMENSIONS IN INCHES - 9 MAY 1972

STA NO.	X	Z	Y	Z	Y	Z	Y	Z	Y	Z	Y	Z	Y	Z
51	13.00													
579	-2.37	.20	-2.29	-.12	-2.04	-.35	-1.70	-.49	-1.25	-.57	-.95	-.59	-.60	-.61
	-.01	-.62	.32	-.62	.84	-.61	1.29	-.59	1.71	-.50	2.12	-.31	2.32	0
52	13.25													
595	-2.40	.10	-2.33	-.16	-2.05	-.37	-1.75	-.49	-1.39	-.56	-.99	-.59	-.61	-.61
	0	-.62	.36	-.62	.90	-.61	1.41	-.58	1.96	-.43	2.28	-.20	2.37	.10
53	13.50													
610	-2.45	.10	-2.36	-.20	-2.03	-.42	-1.62	-.53	-1.16	-.59	-.78	-.60	-.42	-.61
	.01	-.62	.35	-.62	.81	-.61	1.27	-.60	1.76	-.52	2.10	-.40	2.36	-.18
54	13.75													
626	-2.47	0	-2.33	-.29	-1.98	-.46	-1.43	-.56	-.94	-.60	-.55	-.61	-.26	-.62
	.36	-.62	.88	-.61	1.31	-.59	1.60	-.52	2.17	-.41	2.38	-.22	2.44	0
55	14.00													
641	-2.50	0	-2.40	-.28	-2.09	-.44	-1.44	-.57	-.89	-.60	-.54	-.61	-.25	-.61
	.33	-.62	.83	-.61	1.28	-.60	1.71	-.55	2.10	-.46	2.35	-.34	2.48	0
56	14.25													
656	-2.55	0	-2.44	-.31	-2.03	-.48	-1.59	-.56	-1.17	-.59	-.74	-.60	-.48	-.61
	.01	-.62	.31	-.62	.75	-.62	1.28	-.60	1.75	-.56	2.16	-.47	2.41	-.34
57	14.50													
672	-2.58	0	-2.46	-.34	-2.09	-.49	-1.66	-.56	-1.20	-.59	-.77	-.61	-.46	-.61
	0	-.62	.29	-.62	.75	-.62	1.25	-.60	1.74	-.57	2.13	-.50	2.45	-.35
58	14.75													
68	-2.64	0	-2.59	-.27	-2.35	-.44	-2.00	-.52	-1.65	-.56	-1.28	-.59	-1.04	-.60
	-.41	-.62	-.07	-.62	.27	-.62	.79	-.62	1.40	-.60	1.89	-.55	2.31	-.46
	2.59	0												
59	15.00													
705	-2.69	0	-2.62	-.30	-2.30	-.47	-1.79	-.56	-1.20	-.60	-.67	-.61	-.26	-.62
	.32	-.62	.85	-.62	1.38	-.60	1.86	-.57	2.26	-.50	2.60	-.25	2.63	0
60	15.50													
720	-2.76	0	-2.43	-.46	-1.82	-.56	-1.13	-.60	-.61	-.61	0	-.63	.61	-.62
	2.13	-.55	2.63	-.39	2.77	0								
61	16.00													
731	-2.86	0	-2.54	-.46	-1.72	-.57	-.69	-.61	-.46	-.62	0	-.63	.76	-.63
	2.41	-.53	2.81	-.29	2.87	0								
62	16.50													
742	-2.97	0	-2.79	-.38	-2.18	-.55	-1.37	-.60	-.75	-.62	0	-.63	.51	-.63
	1.58	-.61	2.04	-.39	2.52	-.53	2.87	-.37	2.98	0				

AECIARON, INC. WOLD AFS, TENNESSEE
 VON KARMAN GAS DYNAMICS FACILITY
 50 INCH HYPERSONIC TUNNEL B
 V11162

MODEL GEOMETRY - NARDVO BOTTOM SURFACE - ALL DIMENSIONS IN INCHES - 9 MAY 1972

STA NO.	X	Z	Y	Z	Y	Z	Y	Z	Y	Z	Y	Z	Y	Z
63	17.00													
755	-3.08	0	-2.86	-0.39	-2.21	-0.56	-1.46	-0.60	-0.63	-0.62	-0.03	-0.64	.49	-0.63
	1.55	-0.61	2.01	-0.59	2.56	-0.55	2.88	-0.42	3.09	0				1.08
64	17.50													
768	-3.23	0	-3.01	-0.37	-2.48	-0.55	-1.77	-0.59	-1.02	-0.62	-0.38	-0.64	.11	-0.64
	1.02	-0.63	1.52	-0.62	2.05	-0.59	2.62	-0.55	3.03	-0.38	3.22	0		0.63
65	18.00													
782	-3.37	0	-3.12	-0.36	-2.57	-0.55	-1.63	-0.60	-0.60	-0.62	-0.30	-0.64	.13	-0.64
	1.49	-0.62	2.22	-0.59	2.73	-0.54	3.21	-0.34	3.37	-0.01				0.75
66	19.00													
795	-3.82	0	-3.59	-0.32	-3.02	-0.49	-2.42	-0.57	-1.77	-0.60	-0.85	-0.62	0	-0.64
	1.37	-0.62	1.99	-0.60	2.67	-0.57	3.37	-0.42	3.66	-0.25	3.77	0		0.68
67	20.00													
809	-4.32	0	-4.09	-0.28	-3.59	-0.42	-2.80	-0.56	-2.07	-0.59	-1.32	-0.61	-0.64	-0.63
	.69	-0.63	1.47	-0.62	2.30	-0.60	3.04	-0.56	3.75	-0.42	4.17	-0.28	4.34	0
68	21.00													
824	-4.90	.08	-4.76	-0.17	-4.42	-0.30	-3.83	-0.43	-3.22	-0.54	-2.30	-0.59	-1.64	-0.60
	-0.42	-0.63	0	-0.63	.61	-0.63	1.50	-0.62	2.52	-0.61	3.24	-0.57	3.99	-0.44
	4.84	-0.14	4.91	.08										4.59
69	22.00													
842	-5.47	.08	-5.35	-0.14	-4.94	-0.26	-4.34	-0.37	-3.74	-0.47	-3.12	-0.56	-2.36	-0.58
	-0.20	-0.61	-0.14	-0.62	.26	-0.63	.90	-0.63	1.80	-0.61	2.66	-0.61	3.45	-0.55
	5.00	-0.30	5.31	-0.20	5.49	.08								4.31
70	23.00													
861	-6.03	.10	-5.84	-0.13	-5.40	-0.23	-4.83	-0.32	-4.39	-0.39	-3.71	-0.48	-3.21	-0.54
	-2.01	-0.58	-1.33	-0.59	-0.65	-0.60	-0.09	-0.61	.70	-0.61	1.47	-0.60	2.18	-0.60
	3.42	-0.55	4.26	-0.44	4.98	-0.34	5.61	-0.24	5.92	-0.14	6.07	.10		2.87
71	24.00													
883	-6.85	.12	-6.44	-0.08	-5.96	-0.17	-5.48	-0.24	-4.78	-0.33	-4.21	-0.40	-3.48	-0.48
	-2.18	-0.55	-1.39	-0.56	-0.47	-0.57	.11	-0.57	.90	-0.57	1.68	-0.57	2.58	-0.56
	3.93	-0.46	4.81	-0.36	5.74	-0.25	6.42	-0.13	6.64	.12				3.21
72	25.00													
904	-7.22	.14	-6.97	-0.05	-6.35	-0.13	-5.77	-0.19	-5.14	-0.25	-4.45	-0.32	-3.71	-0.39
	-2.25	-0.49	-0.58	-0.50	-0.86	-0.50	-0.12	-0.51	.63	-0.52	1.04	-0.51	1.92	-0.51
	3.83	-0.41	4.98	-0.31	5.57	-0.26	6.28	-0.19	6.93	-0.11	7.21	.13		2.78
73	26.00													
926	-7.70	.27	-7.48	.06	-6.95	-0.05	-6.06	-0.11	-5.34	-0.17	-4.47	-0.24	-3.44	-0.34
	-2.13	-0.42	-1.05	-0.43	-0.21	-0.44	.49	-0.44	1.20	-0.43	2.14	-0.43	2.84	-0.42
	4.99	-0.24	6.06	-0.16	6.81	-0.11	7.20	-0.07	7.57	.07	7.68	.27		3.96

AEDUCARD, INC. RNOLD AFS, TENNESSEE
 VON KARMAN GA. DYNAMICS FACILITY
 50 INCH HYPERSONIC TUNNEL B
 V11162

MODEL GEOMETRY - NARROW BOTTOM SURFACE - ALL DIMENSIONS IN INCHES - 9 MAY 1972

STA NO. POINT NO.	X	Z	Y	Z	Y	Z	Y	Z	Y	Z	Y	Z	Y	Z
74	27.00													
948	-8.08	.40	-7.87	.21	-7.43	.10	-7.07	.03	-6.52	.01	-5.65	-.03	-5.00	-.08
	-3.51	-.23	-2.79	-.30	-1.99	-.32	-.86	-.33	-.16	-.34	.60	-.34	1.35	-.34
	3.24	-.29	4.26	-.19	5.02	-.13	6.04	-.06	6.79	-.03	7.21	0	7.62	.09
	8.07	.40												7.94
75	28.00													
973	-4.30	.54	-8.16	.37	-7.66	.27	-7.19	.20	-6.52	.16	-5.70	.09	-4.46	-.02
	-3.16	-.17	-2.45	-.20	-1.35	-.22	-.51	-.23	.09	-.23	.72	-.23	1.51	-.23
	3.54	-.15	4.77	-.02	5.98	.07	7.01	.13	7.66	.21	8.20	.33	8.31	.54
76	29.00													
996	-6.35	.59	-8.04	.51	-7.30	.43	-6.56	.34	-5.25	.18	-4.28	.07	-3.06	-.07
	-.67	-.12	7.23	-.12	7.96	-.11	1.78	-.11	2.53	-.10	3.32	-.06	4.18	.03
	6.38	.27	7.30	.37	7.89	.44	8.38	.57						5.25
														-.15

12
11
10
9
8
7
6
5
4
3
2
1

AEDUCARD, INC. 7 WOLD AFS, TENNESSEE
 VON KARMAN GAS DYNAMICS FACILITY
 50 INCH HYPERSONIC TUNNEL B
 VT1162

MODEL GEOMETRY - NARROW SIDE SURFACE - ALL DIMENSIONS IN INCHES - 9 MAY 1972

STA NO.	X	Y	Z	X	Y	Z	X	Y	Z	X	Y	Z	X	Y	Z	X	Y	Z	
1	0	0	0																
2	.10	0	-.15	.13	-.12	.17	0	.09	.14	0	.14								
3	.20	0	-.22	.10	-.20	.20	-.14	.25	0	.24	0	.20	.09	.10	.16	.03	.18		
4	.30	.14	-.32	0	-.32	.13	-.28	0	-.28	.27	-.19	.24	-.18	.33	0	.29	0		
5	.50	.09	-.36	0	-.36	.19	-.31	.31	-.18	.35	0	.36	0	.26	.23	.15	.30		
6	1.00	0	-.49	.16	-.47	.29	-.41	.43	-.24	.51	0	.46	.22	.29	.46	.16	.49		
7	1.50	0	-.58	.11	-.56	.24	-.52	.40	-.43	.54	-.25	.62	0	.57	.31	.43	.53		
8	2.00	0	-.63	.11	-.62	.26	-.58	.44	-.48	.63	-.27	.72	0	.72	.24	.61	.50		
9	2.50	0	-.65	.14	-.64	.35	-.58	.54	-.46	.71	-.26	.80	0	.82	.20	.76	.48		
10	3.00	0	-.69	.19	-.65	.49	-.54	.76	-.29	.88	0	.90	.25	.79	.63	.59	.86		
11	3.50	0	-.67	.21	-.65	.51	-.56	.81	-.29	.94	0	.97	.33	.83	.74	.51	1.06		
12	4.00	0	-.67	.24	-.65	.57	-.55	.87	-.28	1.00	0	1.04	.32	.93	.73	.67	1.07		
13	5.00	0	-.67	.41	-.63	.74	-.49	.97	-.28	1.13	0	1.18	.26	1.18	.52	1.05	.86		
119	.80	1.20	.59	1.40	.34	1.51	.15	1.55	0	1.56	0	1.18	.26	1.18	.52	1.05	.86		

AEDUCATION INC. TRIANGLE AFS, TENNESSEE
 VON KARMAN G. DYNAMICS FACILITY
 50 INCH HYPERSONIC TUNNEL B
 VT1162

MODEL GEOMETRY - NARROW SIDE SURFACE - ALL DIMENSIONS IN INCHES - 9 MAY 1972

STA NO.	X	Z	Y	Z	Y	Z	Y	Z	Y	Z	Y	Z	Y	Z
14	5.90	0	0	0	0	0	0	0	0	0	0	0	0	0
132	1.06	1.12	.38	1.46	.69	1.66	1.02	1.74	.31	1.25	0	1.78	0	1.78
15	6.40	0	0	0	0	0	0	0	0	0	0	0	0	0
146	1.40	1.50	.33	1.32	.62	1.13	.82	1.53	.62	1.72	.60	1.75	.59	1.79
16	6.70	0	0	0	0	0	0	0	0	0	0	0	0	0
16A	1.44	1.44	.48	1.37	.84	1.17	.95	1.47	.75	1.69	.69	1.76	.68	1.83
17	7.00	0	0	0	0	0	0	0	0	0	0	0	0	0
192	1.39	1.81	.34	1.47	.30	1.48	.57	1.40	.88	1.21	1.19	1.02	1.45	.83
18	7.50	0	0	0	0	0	0	0	0	0	0	0	0	0
218	1.45	1.87	.18	1.46	0	1.54	.55	1.55	.60	1.47	.91	1.29	1.23	.85
19	8.00	0	0	0	0	0	0	0	0	0	0	0	0	0
246	1.58	1.98	.36	1.62	.38	1.63	.59	1.57	.86	1.45	1.14	1.29	1.36	.92
20	8.50	0	0	0	0	0	0	0	0	0	0	0	0	0
273	1.68	2.26	.20	1.71	.55	1.63	.96	1.39	1.55	1.07	1.76	.88	1.98	.78
21	9.00	0	0	0	0	0	0	0	0	0	0	0	0	0
297	1.56	2.19	.23	1.75	.34	1.78	.59	1.71	.95	1.53	1.29	1.29	1.59	.86
22	10.00	0	0	0	0	0	0	0	0	0	0	0	0	0
322	1.90	2.59	.60	1.83	.64	1.88	.97	1.65	1.60	1.24	1.85	.84	2.26	.75

AEDT/ARJ/INCT VOLVO AF3, TENNESSEE
 VON KARMAN GAS DYNAMICS FACILITY
 50 INCH HYPERSONIC TUNNEL B
 VT1162

MODEL GEOMETRY - NARROW SIDE SURFACE - ALL DIMENSIONS IN INCHES - 9 MAY 1972

STA NO.	X			Y			Z									
	Y	Z	X	Y	Z	X	Y	Z								
23	10.70	-0.65	0.54	-0.64	0.24	-0.64	0.83	-0.63	1.05	-0.61	1.23	-0.56	1.45	-0.47	1.66	-0.32
	0	-0.15	1.92	0	1.93	0	2.00	0.28	2.02	0.52	2.02	0.75	1.93	1.14	1.69	1.52
	1.43	1.77	1.21	1.99	1.02	2.19	0.64	2.35	0.71	2.44	0.59	2.51	0.42	2.58	0.30	2.62
	0.11	2.65	0.04	2.65	0	2.66										
24	11.00	-0.65	0	-0.65	0.78	-0.64	0.46	-0.64	1.00	-0.62	1.28	-0.56	1.54	-0.44	1.79	-0.26
	0	0	2.04	0.18	2.06	0.38	2.07	0.57	2.06	0.88	1.94	1.24	1.65	1.63	1.38	1.88
	1.98	0	1.10	2.15	0.89	2.34	0.77	2.44	0.57	2.54	0.42	2.60	0.19	2.64	0	2.65
25	12.00	-0.65	0.31	-0.65	0	-0.65	0.90	-0.64	1.17	-0.62	1.41	-0.57	1.67	-0.48	1.88	-0.37
	0.56	-0.18	2.18	0	2.23	0.32	2.22	0.80	2.14	1.19	1.81	1.67	1.31	2.05	1.12	2.20
	2.07	2.33	0.70	2.48	0.45	2.58	0.19	2.64	0	2.65						
26	13.00	-0.65	0	-0.65	0.72	-0.64	1.09	-0.63	1.44	-0.60	1.82	-0.51	2.11	-0.36	2.27	-0.21
	0.39	0	2.37	0.41	2.37	0.80	2.25	1.34	1.87	1.82	1.60	2.00	1.37	2.13	1.15	2.26
	2.35	0	0.85	2.42	0.63	2.52	0.36	2.62	0.08	2.65	0	2.65				
27	14.00	-0.65	0.36	-0.65	0	-0.65	1.04	-0.64	1.41	-0.62	1.84	-0.56	2.12	-0.49	2.33	-0.40
	0.69	-0.25	2.50	0	2.52	0.28	2.52	0.60	2.51	1.00	2.39	1.42	2.11	1.81	1.69	2.09
	2.46	1.41	2.22	1.17	2.32	0.94	2.42	0.66	2.53	0.33	2.63	0.11	2.65	0	2.66	
28	15.00	-0.65	0.35	-0.65	0	-0.65	1.18	-0.64	1.66	-0.62	2.04	-0.57	2.38	-0.50	2.56	-0.39
	0.71	-0.26	2.67	0.09	2.66	0	2.64	0.10	2.65	0.30	2.66	0.56	2.66	0.86	2.59	1.30
	2.65	1.62	2.18	1.92	1.77	2.18	1.45	2.30	1.12	2.40	0.83	2.49	0.56	2.57	0.33	2.63
29	16.00	-0.67	0	-0.67	1.09	-0.66	1.68	-0.64	2.18	-0.61	2.43	-0.57	2.63	-0.51	2.76	-0.43
	0.47	-0.30	2.89	0.15	2.89	0.60	2.88	0	2.84	0.12	2.77	0.22	2.77	0.29	2.79	0.57
	2.85	2.79	0.85	2.75	1.21	2.59	1.61	2.31	1.96	1.82	2.25	1.53	2.35	1.27	2.42	1.01
	0.75	2.56	0.38	2.64	0.21	2.66	0	2.67								
30	17.00	-0.68	0.79	-0.67	0.46	-0.67	1.31	-0.66	1.91	-0.64	2.37	-0.62	2.54	-0.60	2.79	-0.52
	0	-0.43	3.07	-0.30	3.12	-0.09	3.11	0	3.05	0.10	2.98	0.18	2.86	0.28	2.85	0.34
	2.95	2.86	0.54	2.86	0.87	2.83	1.17	1.48	2.60	1.11	2.30	2.03	1.94	2.24	1.53	2.37
	1.18	2.46	0.89	2.53	0.63	2.59	0.37	2.64	0.09	2.67	0	2.67				
31	18.00	-0.68	0	-0.68	1.23	-0.67	1.89	-0.64	2.44	-0.63	2.61	-0.61	2.87	-0.55	3.04	-0.49
	0.48	-0.41	3.34	-0.29	3.39	-0.15	3.39	0	3.34	0.10	3.21	0.19	3.06	0.26	2.93	0.32
	2.92	2.92	0.35	2.92	0.45	2.92	0.75	2.89	1.15	2.75	1.55	2.50	1.90	2.06	2.21	1.57
	1.21	2.46	0.40	2.56	0.47	2.62	0.15	2.67	-0.02	2.67						

MEMPHIS AIRCRAFT OLD AFSS, TENNESSEE
 VON KARMAN GAS DYNAMICS FACILITY
 50 INCH HYPERSONIC TUNNEL B
 VII162

30

MODEL GEOMETRY - NARROW SIDE SURFACE - ALL DIMENSIONS IN INCHES - 9 MAY 1972

STA NO. POINT NO.	X			Y			Z									
	X	Y	Z	X	Y	Z	X	Y	Z							
32	19.00															
571	.80	-.68	.39	-.68	0	-.68	1.28	-.67	1.72	-.66	2.19	-.64	2.49	-.63	2.71	-.62
	2.98	-.57	3.26	-.50	3.54	-.42	3.66	-.35	3.76	-.23	3.80	0	3.79	0	3.75	.08
	3.64	.18	3.49	.24	3.31	.29	3.13	.33	3.01	.36	2.99	.40	2.99	.57	2.98	.86
	2.94	1.21	2.79	1.60	2.57	1.90	2.10	2.22	1.53	2.40	.92	2.54	.66	2.60	.34	2.65
	.13	2.67	0	2.67												
3	20.00															
605	.41	-.69	0	-.69	.98	-.68	1.65	-.66	2.24	-.65	2.71	-.64	2.97	-.62	3.24	-.58
	3.59	-.51	3.94	-.42	4.15	-.34	4.26	-.26	4.32	-.16	4.36	-.07	4.35	0	4.29	.10
	4.15	.21	3.96	.27	3.65	.32	3.35	.35	3.11	.38	3.07	.40	3.05	.44	3.04	.66
	3.04	.94	2.99	1.28	2.86	1.60	2.67	1.86	2.31	2.15	1.95	2.30	1.34	2.45	.82	2.57
	.46	2.63	.24	2.66	0	2.67										
34	21.00															
640	0	-.69	.84	-.68	1.66	-.68	2.38	-.65	3.00	-.63	3.21	-.61	3.53	-.56	4.00	-.47
	4.43	-.39	4.67	-.31	4.81	-.23	4.90	-.10	4.93	0	4.89	.09	4.74	.21	4.56	.27
	4.34	.31	4.23	.33	3.93	.36	3.65	.39	3.34	.40	3.15	.41	3.13	.42	3.12	.44
	3.11	.54	3.11	.81	3.08	1.17	3.01	1.42	2.84	1.74	2.52	2.07	2.07	2.29	1.42	2.45
	1.03	2.54	.79	2.58	.48	2.64	.27	2.67	0	2.68						
35	22.00															
677	0	-.70	1.30	-.69	2.30	-.67	3.19	-.65	3.54	-.60	4.13	-.51	4.67	-.42	5.11	-.33
	5.31	-.25	5.42	-.17	5.48	-.07	5.50	0	5.45	.10	5.34	.18	5.22	.24	5.00	.29
	4.70	.34	4.32	.37	3.82	.40	3.45	.42	3.19	.43	3.17	.46	3.17	.66	3.14	1.14
	2.91	1.72	2.45	2.15	1.76	2.38	1.01	2.54	.58	2.62	.29	2.66	0	2.68		
36	23.00															
9	.69	-.68	0	-.68	1.86	-.66	2.96	-.65	3.20	-.64	3.51	-.60	4.30	-.49	4.98	-.39
	5.59	-.29	5.86	-.22	6.01	-.12	6.07	0	6.05	.08	5.94	.17	5.65	.28	5.35	.33
	4.96	.37	4.53	.40	3.78	.42	3.23	.43	3.22	.44	3.21	.46	3.20	.80	3.17	1.20
	3.01	1.63	2.79	1.92	2.42	2.19	1.86	2.37	1.38	2.47	.89	2.57	.37	2.65	0	2.67
37	24.00															
740	.88	-.64	0	-.64	1.78	-.63	2.80	-.61	3.14	-.60	3.62	-.55	4.22	-.48	4.89	-.40
	5.62	-.31	6.13	-.24	6.44	-.17	6.59	-.07	6.63	0	6.63	.11	6.54	.18	6.33	.28
	6.05	.34	5.89	.36	5.66	.38	5.39	.40	5.00	.42	4.16	.44	3.23	.44	3.22	.52
	3.21	.74	3.19	1.06	3.11	1.43	2.92	1.77	2.50	2.14	2.08	2.31	1.60	2.42	1.02	2.54
	.52	2.63	.20	2.67	0	2.68										
38	25.00															
775	0	-.55	2.14	-.58	.93	-.58	3.04	-.54	3.31	-.52	4.26	-.43	5.13	-.35	5.83	-.27
	6.64	-.18	7.02	-.11	7.14	-.06	7.19	0	7.21	.07	7.17	.15	7.02	.24	6.76	.32
	6.33	.39	6.02	.42	5.78	.43	5.19	.44	3.22	.44	3.22	.59	3.20	.97	3.14	1.31
	3.00	1.64	2.80	1.90	2.41	2.18	2.03	2.31	1.60	2.41	1.35	2.46	.94	2.54	.55	2.61
	.25	2.66	0	2.68												
39	25.40															
809	1.59	-.56	.64	-.56	0	-.56	2.53	-.55	3.00	-.52	4.04	-.42	5.36	-.31	6.21	-.23
	7.03	-.15	7.25	-.08	7.37	0	7.42	.10	7.33	.16	7.19	.21	7.03	.26	6.85	.30
	6.45	.36	6.05	.38	5.39	.39	3.21	.39	3.20	.73	3.14	1.24	2.94	1.67	2.49	2.09
	1.99	2.27	1.38	2.40	.74	2.52	.41	2.58	.15	2.62	0	2.64				

AEDTARDJINCJ ARNOLD AFS, TENNESSEE
 VON KARMAN GAS DYNAMICS FACILITY
 50 INCH HYPERSONIC TUNNEL B
 V11162

41

MUDEL GEOMETRY - WARDNO SIDE SURFACE - ALL DIMENSIONS IN INCHES - 9 MAY 1972

STA NO.	X	Y	Z	X	Y	Z	X	Y	Z	X	Y	Z	X	Y	Z
49	32.00														
1071	0	6.04		.01	6.48		.03	7.08		.03	7.41		0	7.52	
50	32.70														
1076	0	7.52													

12
 11
 10
 9
 8
 7
 6
 5
 4
 3
 2
 1

Table 3

PHASE CHANGE COATING TEST DATA SUMMARY SHEET

TEST TITLE: Ascent Heat Transfer Test of GDC-B+NAR-DMO

TEST NUMBER: VTT162-11 TEST FACILITY: VKF Tunnel B

TEST DATE: June 1971 TEST ENGINEER: R. K. Matthews & W. R. Martindale

Run No.	Model Configuration Identification	Model Scale	Free Stream Mach Number	Total Pressure (psia)	Total Temp. (°R)	Taw * Total	RNX106 Ft	Phase Change Temp. (°F)	Model Position (degrees)			Model Surface
									α	β	ϕ	
232	GDC-B + NAR-DMO	0.013	8.0	265	1270	1.0	1.25	250	0	0	0	Side
233								125	0			
230								250	-5			
231								125	-5			
228								250	5			
229								125	5			
238				567	1310		2.55	275	0			
239								150	0			
236								275	-5			
237								150	-5			
234								300	5			
235								150	5			
242						N/A		0. F**	0			

* Taw - adiabatic wall temperature

**0.F. = 011 FLOW

PHASE CHANGE COATING TEST DATA SUMMARY SHEET

TEST TITLE: Ascent Heat Transfer Test of GDC-B+MAR-DMO

TEST NUMBER: VT1162-11

TEST FACILITY: VKF Tunnel 8

TEST DATE: June 1971

TEST ENGINEER: R. K. Matthews and W. R. Martindale

Run No.	Model Configuration Identification	Model Scale	Free Stream Mach Number	Total Pressure (psia)	Total Temp. (°R)	T _{aw} * / Total	RN _{X106} / Ft	Phase Change Temp. (°F)	Model Position (degrees)			Model Surface
									α	β	φ	
241	GDC-B + MAR-DMO	0.013	8.0	567	1310	N/A	2.55	0.F.**	-5	0	0	Side
240								0.F.	5			
260								Sha***	0		0	
261								Sha	0		90	
258								Sha	-5		0	
259								Sha	5		0	

* T_{aw} = adiabatic wall temperature
 **0.F. = 011 FLOW
 ***Sha = Shadowgraphs

TABLE 4. SUMMARY DATA INDEX

CONFIGURATION	MODEL SURFACE	DATA PRESENTED	PAGE	REYNOLDS NUMBER $\times 10^6$ / FT		ANGLE OF ATTACK - DEGREES			
				1.25	2.55	-5	0	5	
<u>Booster-Orb.</u>	<u>Side</u>	A	46 - 47	X					
			49 - 50	X			X		
			52 - 53	X			X		
			55 - 56	X					X
			58 - 59	X					X
			61 - 62	X					
			64 - 65		X			X	
			67 - 68		X			X	
			70 - 71		X			X	
			73 - 74		X			X	
			76 - 77		X				X
			79 - 80		X				X
			82		X			X	
84		X				X			
86		X				X			
87		X				X			
88		X				X			
89		X				X			
90		X				X			
<u>Booster-Orb.</u>	<u>Side</u>	B	88						
			89				X		
			90					X	

PRESENTED DATA SCHEDULE

- A: PHASE-CHANGE PAINT PHOTOGRAPHS
- B: SHADOWGRAPH PHOTOGRAPHS
- C: OIL FLOW PHOTOGRAPHS

6/ 4/71

AEDCIARO, INC.) ARNOLD AFS, TENNESSEE
VON KARMAN GAS DYNAMICS FACILITY
50 INCH HYPERSONIC TUNNEL, B
V11162

GROUP CONFIG MODEL MACH NO PO PSIA TO DEG R ALPHA-MODEL ALPHA-SECTOR ALPHA-PREBEND ROLL-MODEL YAW
232 6153 EDC-B-DMD 7.97 262.6 1273 .03 .03 0 0 0

T-INF P-INF Q-INF V-INF RHO-INF MU-INF RE/FT HREF STREF
(DEG R) (PSIA) (PSIA) (FT/SEC) (SLUGS/FT³) (LB-SEC/FT²) (FT-1) (R = .013FT) (H = .013FT)
92.9 .028 1.226 3764 2.490E-05 7.479E-08 1.25E 06 3.177E-02 4.229E-02

CAVEA PAINT TEMP (DEG F) INITIAL TEMP (DEG F) SQUARE ROOT (RHOCXK)
TOP(T) 250
SIDE(US) 250 AVERAGE TW = 75 (R)
SIDE(LS) 250 AVERAGE TW = 88 (C)

-.008(SQUARE ROOT DEL TIME) * 0.11

PGC NO	TIME DELTIME	H(TO)	H(TO)/HREF	H(.910)	H(.910)/HREF	H(.8510)	H(.8510)/HREF	S(ITO)	MODEL	TEMP F
LS 3421 (250)	3.60	2.53	0 1.48E-02	.4649	1.884E-02	.5929	2.186E-02	.6880	1.957E-02	74 74 90 87
LS 3421 (250)	3.60	2.53	R 1.59E-02	.5015	2.031E-02	.6391	2.356E-02	.7412	2.111E-02	74 74 90 87
LS 3421 (250)	3.60	2.53	R 1.59E-02	.5015	2.031E-02	.6391	2.356E-02	.7412	2.111E-02	74 74 90 87
LS 3421 (250)	3.60	2.53	0 1.48E-02	.4649	1.884E-02	.5929	2.186E-02	.6880	1.957E-02	74 74 90 87
LS 3433 (250)	9.70	8.63	0 7.12E-03	.2239	9.076E-03	.2855	1.053E-02	.3313	9.421E-03	77 74 93 94
LS 3433 (250)	9.70	8.63	R 7.68E-03	.2415	9.284E-03	.3078	1.135E-02	.3569	1.016E-02	77 74 93 94
LS 3433 (250)	9.70	8.63	R 7.68E-03	.2415	9.284E-03	.3078	1.135E-02	.3569	1.016E-02	77 74 93 94
LS 3433 (250)	9.70	8.63	0 7.12E-03	.2239	9.076E-03	.2855	1.053E-02	.3313	9.421E-03	77 74 93 94
LS 3445 (250)	15.85	14.78	0 4.98E-03	.1566	6.355E-03	.1997	7.373E-03	.2318	6.585E-03	79 75 95 102
LS 3445 (250)	15.85	14.78	R 5.37E-03	.1689	6.850E-03	.2153	7.944E-03	.2497	7.103E-03	79 75 95 102
LS 3445 (250)	15.85	14.78	R 5.37E-03	.1689	6.850E-03	.2153	7.944E-03	.2497	7.103E-03	79 75 95 102
LS 3445 (250)	15.85	14.78	0 4.98E-03	.1566	6.355E-03	.1997	7.373E-03	.2318	6.585E-03	79 75 95 102
LS 3458 (250)	26.65	25.58	0 3.32E-03	.1044	4.239E-03	.1332	4.919E-03	.1545	4.388E-03	83 78 99 113
LS 3458 (250)	26.65	25.58	R 3.59E-03	.1126	4.569E-03	.1435	5.299E-03	.1665	4.733E-03	83 78 99 113
LS 3458 (250)	26.65	25.58	R 3.59E-03	.1126	4.569E-03	.1435	5.299E-03	.1665	4.733E-03	83 78 99 113
LS 3458 (250)	26.65	25.58	0 3.32E-03	.1044	4.239E-03	.1332	4.919E-03	.1545	4.388E-03	83 78 99 113

Orbiter(o)
Booster(B)

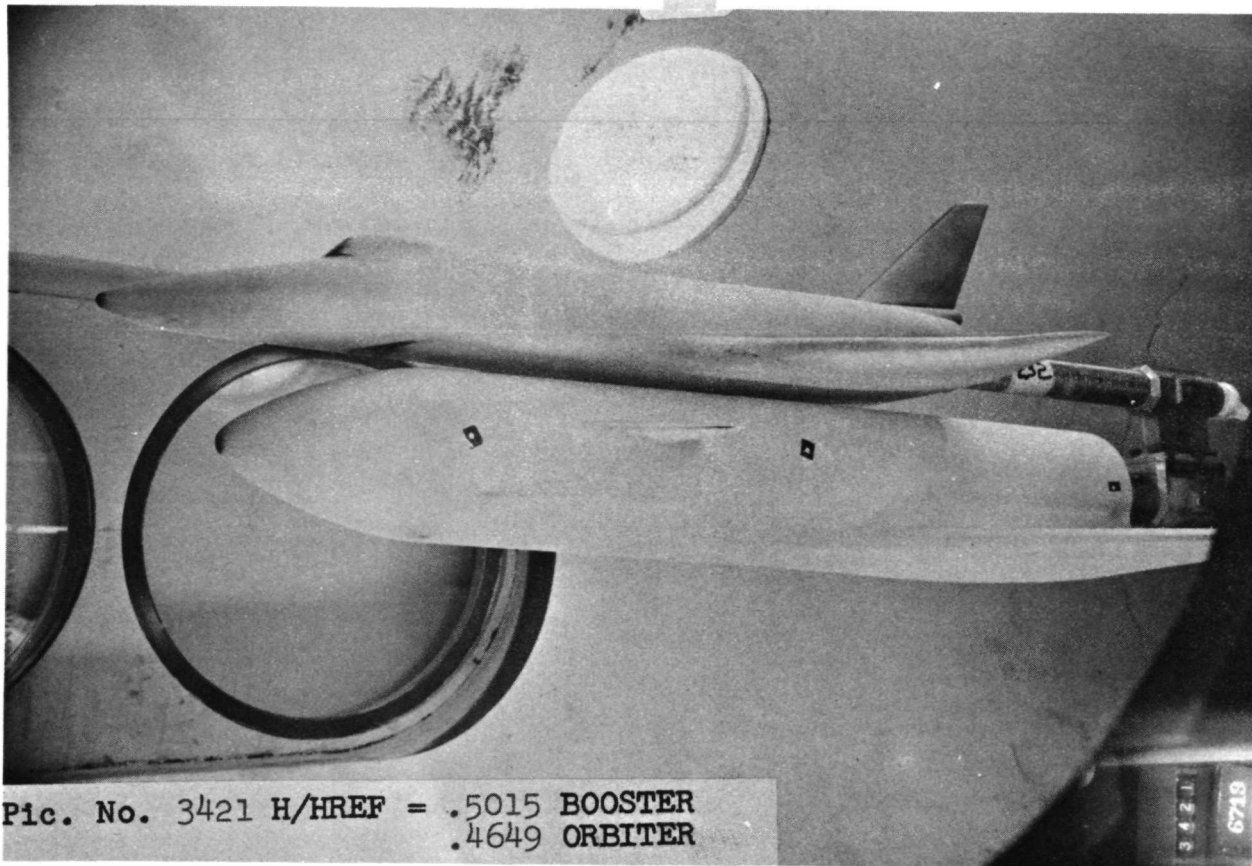

Pic. No. 3421 H/HREF = .5015 BOOSTER
 .4649 ORBITER

3421
 6719

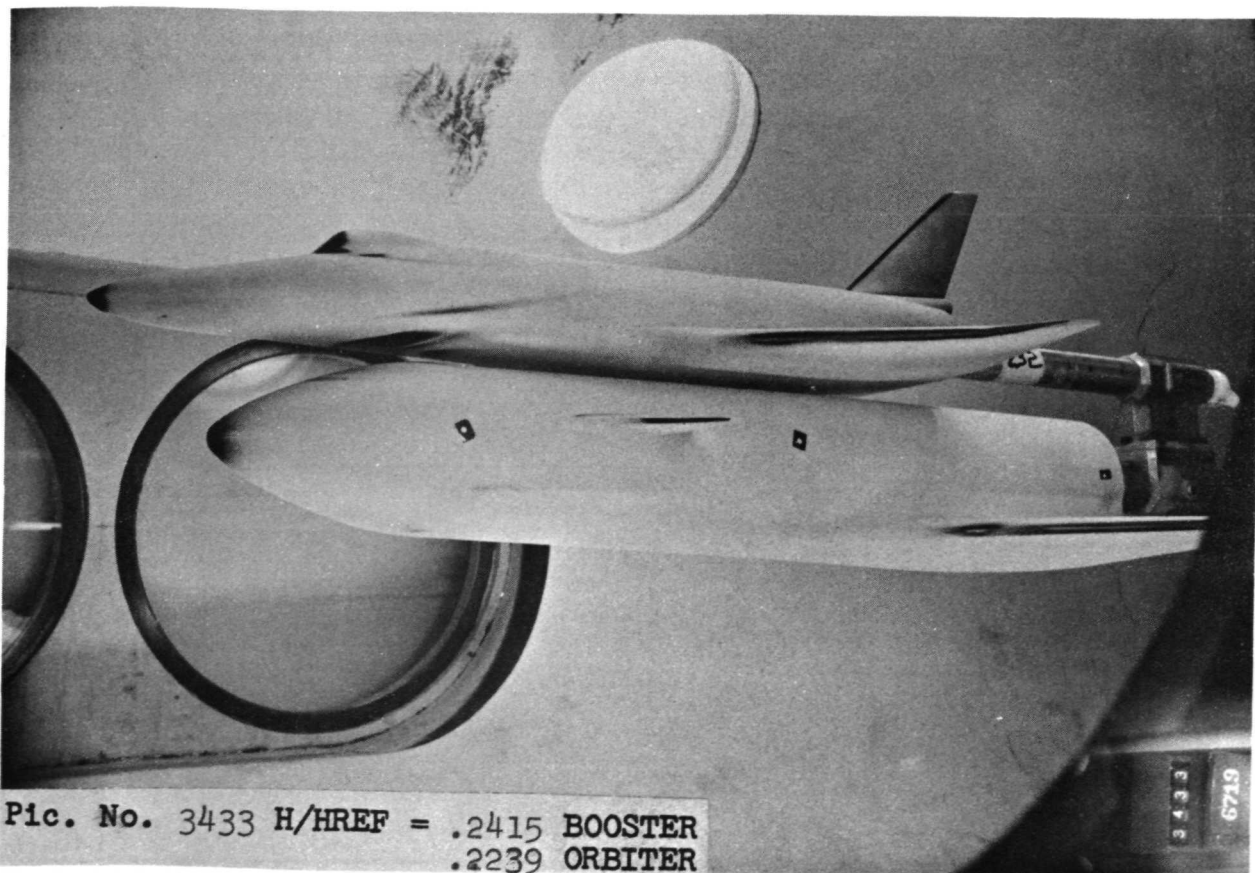

Pic. No. 3433 H/HREF = .2415 BOOSTER
 .2239 ORBITER

3433
 6719

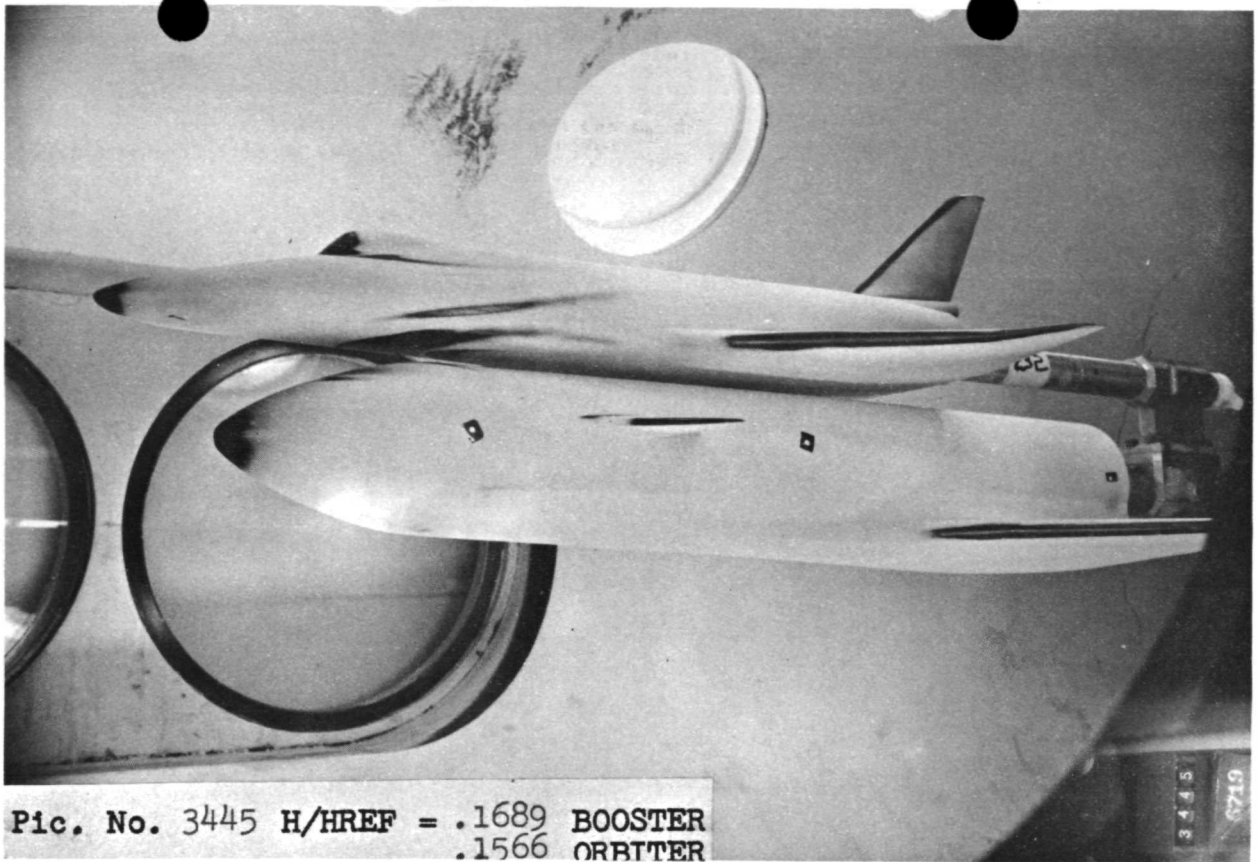

Pic. No. 3445 H/HREF = .1689 BOOSTER
.1566 ORBITER

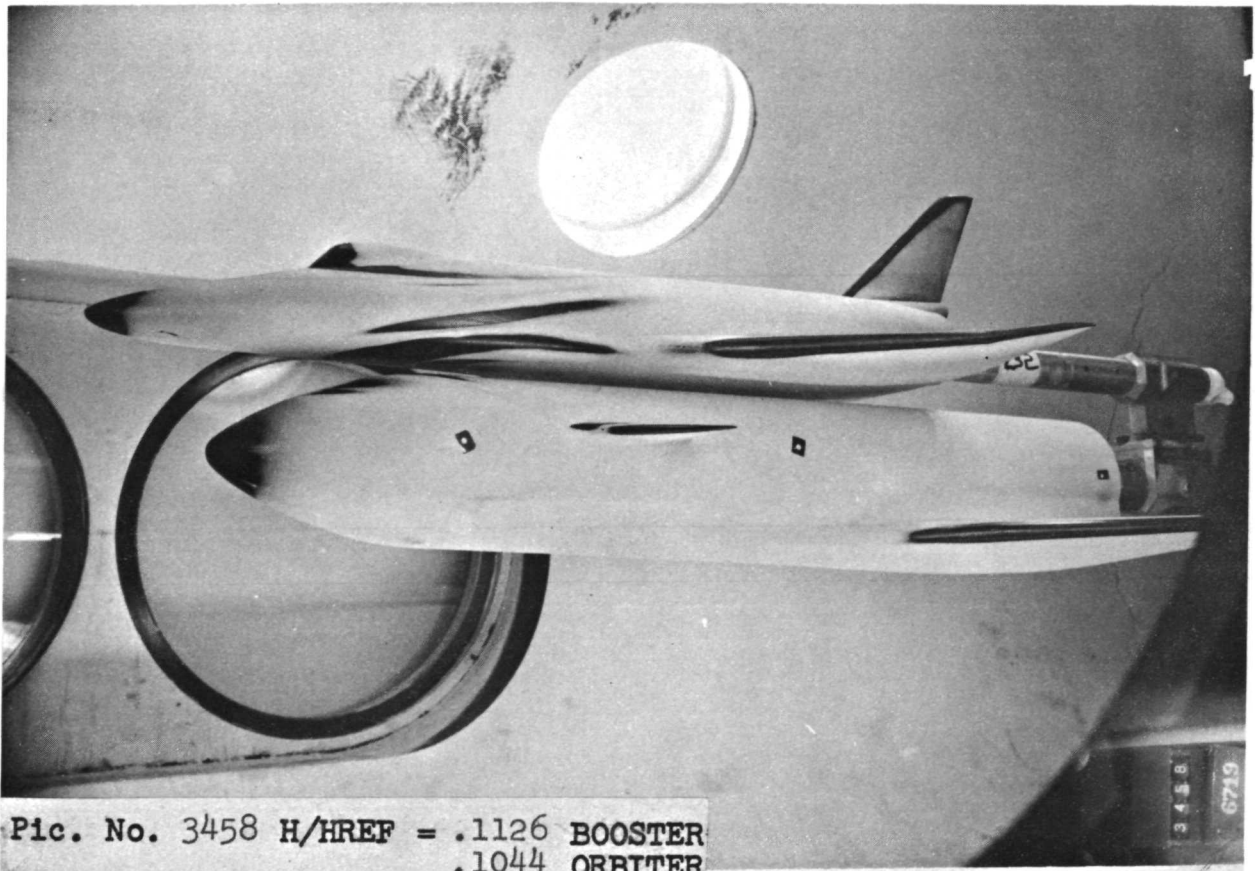

Pic. No. 3458 H/HREF = .1126 BOOSTER
.1044 ORBITER

6/ 4/71

AECCIANO, INC.) ARNOLD AFS, TENNESSEE
VOM KARMAN GAS DYNAMICS FACILITY
50 INCH HYPERSONIC TUNNEL B
V11162

GROUP 233 CONF IG 6253 MODEL EDC-B+DWD MACH NO 7.97 PO PSIA 266.4 TU DEG R 1275 ALPHA-MODEL -1.00 ALPHA-SECTOR -1.00 ALPHA-PREBEND 0 ROLL-MODEL 0 YAW 0

T-1NF P-1NF Q-1NF V-1NF RM0-1NF MU-1NF RE/FT HREF STREF
(DEG R) (PSIA) (PSIA) (FT/SEC) (SLUGS/FT3) (LB-SEC/FT2) (FT-1) (R=.013FT) (R=.013FT)
93.0 .028 1.243 3767 2.522E-05 7.490E-08 1.27E-06 3.202E-02 4.203E-02

CAMERA PAINT TEMP (DEG F) INITIAL TEMP (DEG F) SQUARE ROOT (RHOXCKX)

TOP(T) 125 AVERAGE TM = 73 (R)
ICE(USI) 125 AVERAGE TW = 89 (O)
ICE(LS) 125

PIC NC	TIME DELT	H(TO)	H(TO)/HREF	H(.91TO)	H(.91TO)/HREF	H(.85TO)	H(.85TO)/HREF	SI(TO)	MODEL	TEMP F
LS 3469 (125)	3.70	2.63	0.271E-03	.0848	3.320E-03	.1037	3.741E-03	.1169	3.572E-03	0 73 91 89
LS 3469 (125)	3.70	2.63	8.3.91E-03	.1222	4.781E-03	.1494	5.379E-03	.1681	5.148E-03	0 73 91 89
LS 3469 (125)	3.70	2.63	0.3.91E-03	.1222	4.781E-03	.1494	5.379E-03	.1681	5.148E-03	0 73 91 89
LS 3469 (125)	3.70	2.63	0.2.71E-03	.0848	3.320E-03	.1037	3.741E-03	.1169	3.572E-03	0 73 91 89
LS 3479 (125)	8.95	7.88	0.1.42E-03	.0442	1.731E-03	.0541	1.951E-03	.0609	1.863E-03	0 74 93 95
LS 3479 (125)	8.95	7.88	8.2.04E-03	.0637	2.493E-03	.0779	2.805E-03	.0876	2.685E-03	0 74 93 95
LS 3479 (125)	8.95	7.88	0.2.04E-03	.0637	2.493E-03	.0779	2.805E-03	.0876	2.685E-03	0 74 93 95
LS 3479 (125)	8.95	7.88	0.1.42E-03	.0442	1.731E-03	.0541	1.951E-03	.0609	1.863E-03	0 74 93 95
LS 3489 (125)	14.20	13.13	0.1.01E-03	.0317	1.241E-03	.0388	1.399E-03	.0437	1.336E-03	0 75 96 101
LS 3489 (125)	14.20	13.13	8.1.46E-03	.0457	1.787E-03	.0559	2.011E-03	.0628	1.926E-03	0 75 96 101
LS 3489 (125)	14.20	13.13	8.1.46E-03	.0457	1.787E-03	.0559	2.011E-03	.0628	1.926E-03	0 75 96 101
LS 3489 (125)	14.20	13.13	0.1.01E-03	.0317	1.241E-03	.0388	1.399E-03	.0437	1.336E-03	0 75 96 101
LS 3501 (125)	24.15	23.08	0.6.76E-04	.0211	8.272E-04	.0258	9.320E-04	.0291	8.897E-04	0 79 99 113
LS 3501 (125)	24.15	23.08	8.9.75E-04	.0305	1.191E-03	.0372	1.340E-03	.0419	1.282E-03	0 79 99 113
LS 3501 (125)	24.15	23.08	8.9.75E-04	.0305	1.191E-03	.0372	1.340E-03	.0419	1.282E-03	0 79 99 113
LS 3501 (125)	24.15	23.08	0.6.76E-04	.0211	8.272E-04	.0258	9.320E-04	.0291	8.897E-04	0 79 99 113

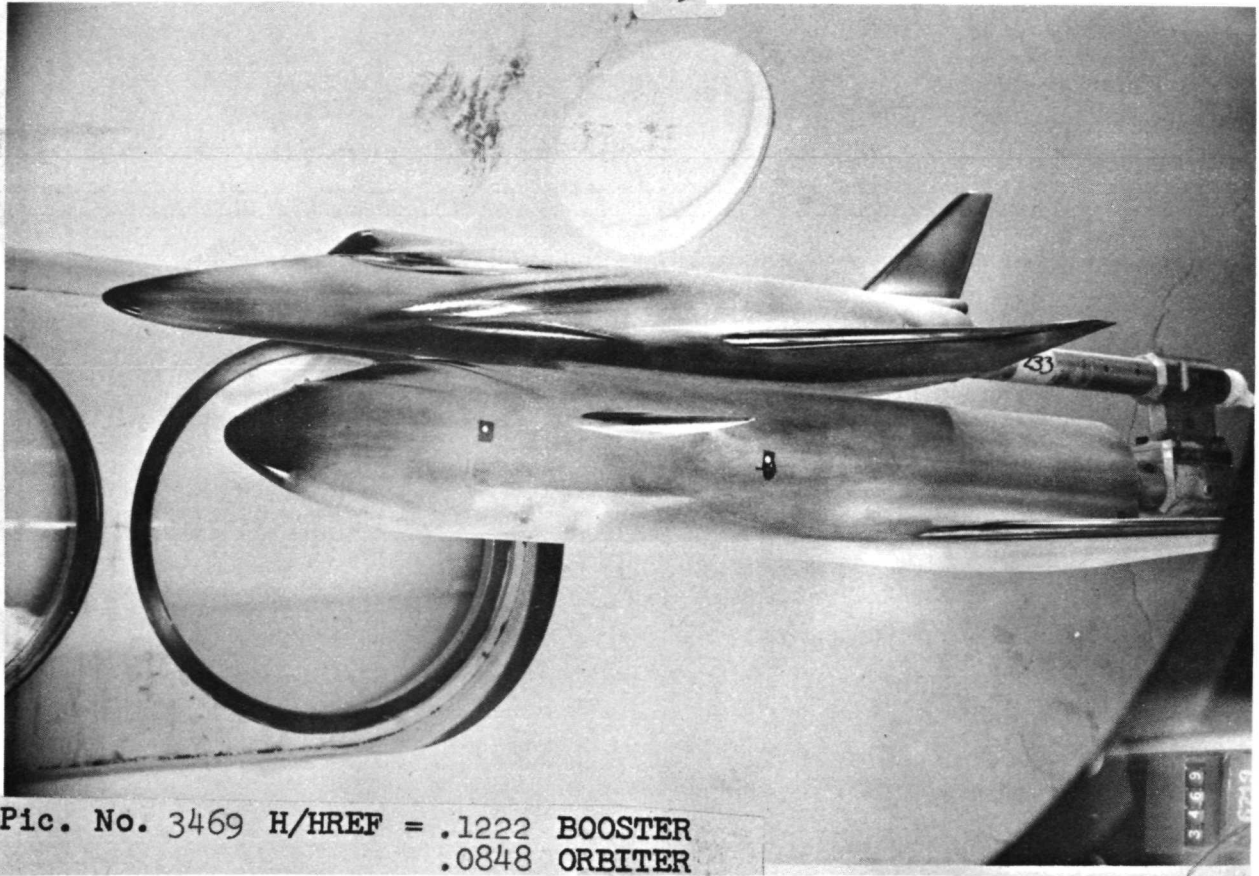

Pic. No. 3469 H/HREF = .1222 BOOSTER
.0848 ORBITER

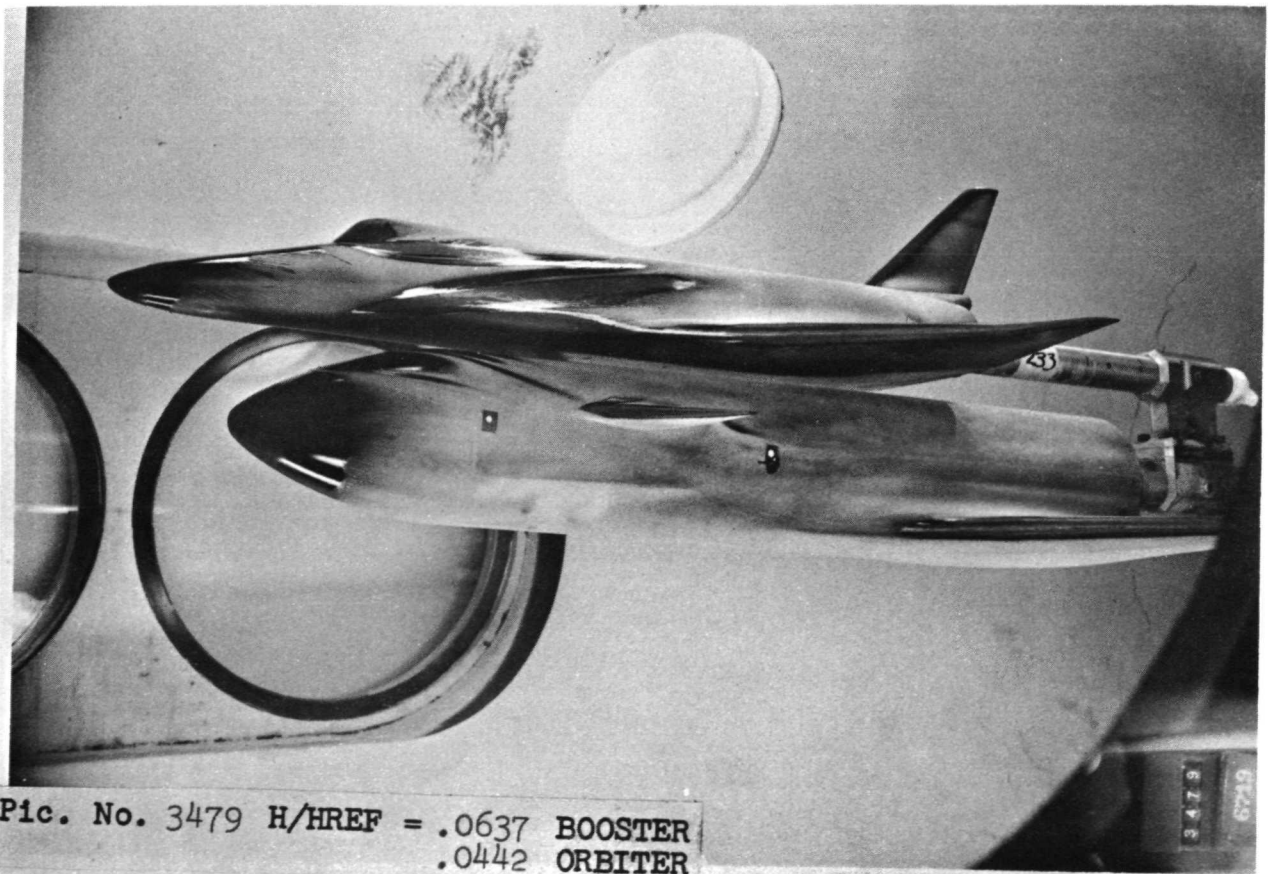

Pic. No. 3479 H/HREF = .0637 BOOSTER
.0442 ORBITER

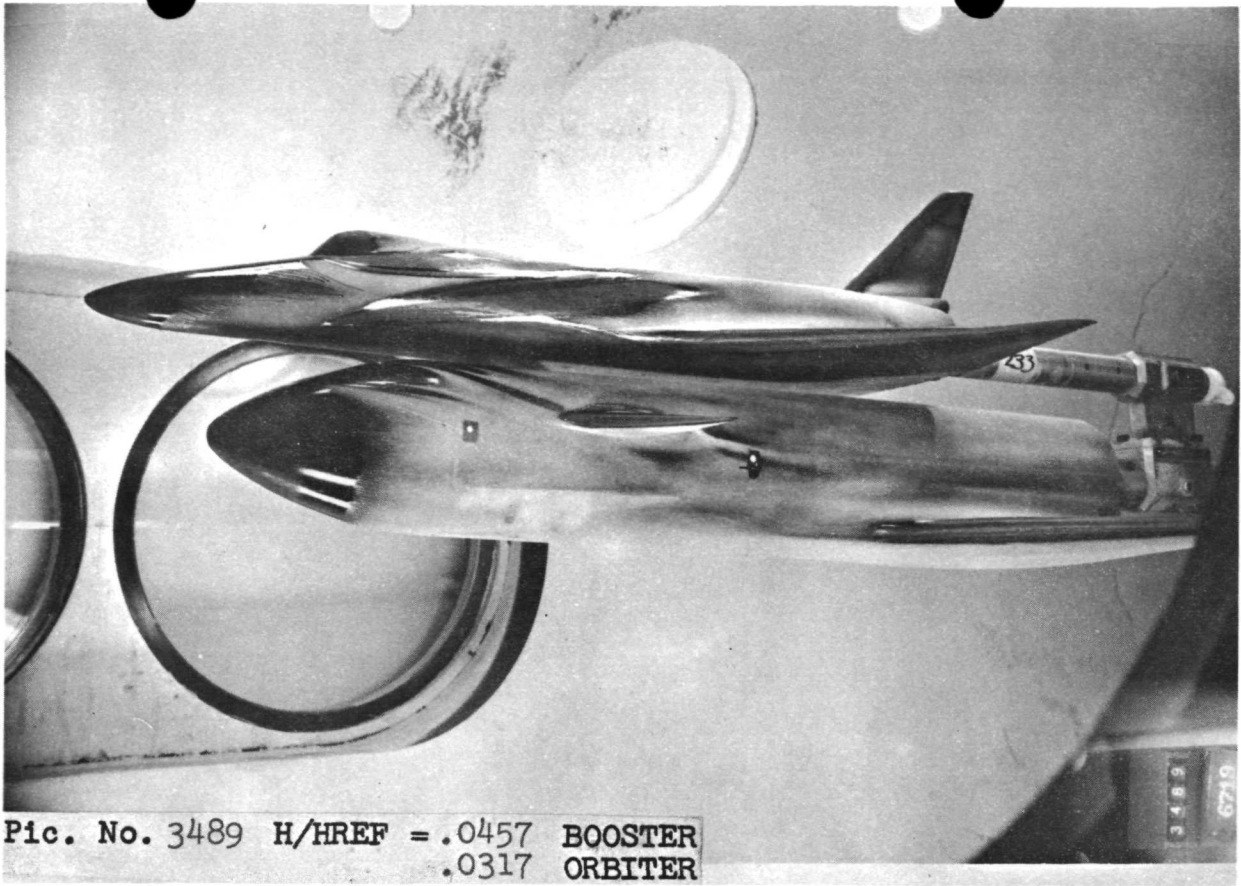

Pic. No. 3489 H/HREF = .0457 BOOSTER
 .0317 ORBITER

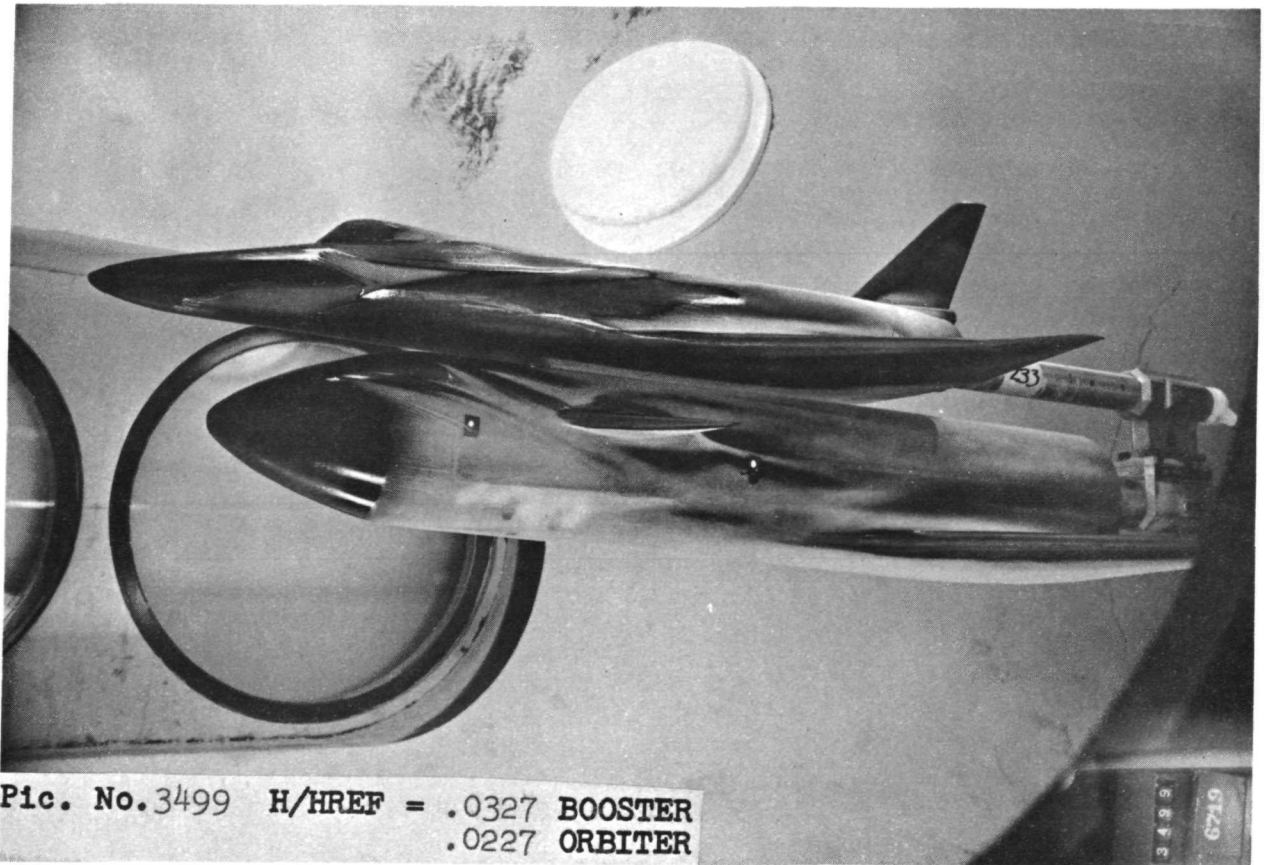

Pic. No. 3499 H/HREF = .0327 BOOSTER
 .0227 ORBITER

6/ 4/71

AEDICARO, INC.) ARNOLD AFS, TENNESSEE
VON KARMAN GAS DYNAMICS FACILITY
50 INCH HYPERSONIC TUNNEL B
V111162

GROUP 228 CONFIG 6151 MODEL GDC-RSDWN MACH NO 7.97 PO PSIA 263.6 TO DEG R 1267 ALPHA-PANEL 5.01 ALPHA-SECTOR 5.01 ALPHA-PREBEND 0 ROLL-MODEL 0 YAW 0

T-INF P-INF 0-INF V-INF RHO-INF MU-INF RE/FT HRF STHEF
(DEG R) (PSIA) (PSIA) (FT/SEC) (SLUGS/FT³) (LB-SEC/FT²) (FT-1) (R=.013FT) (R=.013FT)
92.5 .028 1.230 3755 2.511E-05 7.845E-08 1.27E 06 3.101E-02 4.210E-02

CAMERA PAINT TEMP (DEG F) INITIAL TEMP (DEG F) SQUARE FOOT (RHODCK)

TOP(T) 250 AVERAGE TW = 74 (R)
SIDE(S) 250 AVERAGE TW = 73 (C) -.008(SQUARE FOOT DEL TIME) + 0.11

PIC NC	TIME DELTIME	H(TO)	H(TO)/HREF	H(.910)	H(.910)/HREF	H(.85TU)	H(.85TU)/HREF	ST(TO)	MODEL TEMP F
LS 3227 (250)	3.65 2.58	0 1.60E-02	.5032	2.043E-02	.6421	2.371E-02	.7454	2.109E-02	73 73 74 74
LS 3227 (250)	3.65 2.58	R 1.60E-02	.5027	2.041E-02	.6415	2.369E-02	.7447	2.107E-02	73 73 74 74
LS 3227 (250)	3.65 2.58	R 1.60E-02	.5027	2.041E-02	.6415	2.369E-02	.7447	2.107E-02	73 73 74 74
LS 3227 (250)	3.65 2.58	O 1.60E-02	.5032	2.043E-02	.6421	2.371E-02	.7454	2.109E-02	73 73 74 74
LS 3239 (250)	9.90 R.R3	0 7.68E-03	.2415	9.805E-03	.3082	1.138E-02	.3578	1.012E-02	77 74 77 79
LS 3239 (250)	9.90 R.R3	R 7.68E-03	.2413	9.795E-03	.3079	1.137E-02	.3574	1.011E-02	77 74 77 79
LS 3239 (250)	9.90 R.R3	R 7.68E-03	.2413	9.795E-03	.3079	1.137E-02	.3574	1.011E-02	77 74 77 79
LS 3239 (250)	9.90 R.R3	O 7.68E-03	.2415	9.805E-03	.3082	1.138E-02	.3578	1.012E-02	77 74 77 79
LS 3251 (250)	16.05 14.98	O 5.41E-03	.1700	6.901E-03	.2170	8.011E-03	.2519	7.120E-03	80 76 80 85
LS 3251 (250)	16.05 14.98	R 5.40E-03	.1698	6.894E-03	.2168	8.002E-03	.2516	7.120E-03	80 76 80 85
LS 3251 (250)	16.05 14.98	R 5.40E-03	.1698	6.894E-03	.2168	8.002E-03	.2516	7.120E-03	80 76 80 85
LS 3251 (250)	16.05 14.98	O 5.41E-03	.1700	6.901E-03	.2170	8.011E-03	.2519	7.120E-03	80 76 80 85
LS 3264 (250)	28.04 26.97	O 3.49E-03	.1098	4.454E-03	.1401	5.171E-03	.1627	4.604E-03	87 80 85 94
LS 3264 (250)	28.04 26.97	R 3.49E-03	.1097	4.450E-03	.1400	5.166E-03	.1625	4.593E-03	87 80 85 94
LS 3264 (250)	28.04 26.97	R 3.49E-03	.1097	4.450E-03	.1400	5.166E-03	.1625	4.593E-03	87 80 85 94
LS 3264 (250)	28.04 26.97	O 3.49E-03	.1098	4.454E-03	.1401	5.171E-03	.1627	4.604E-03	87 80 85 94

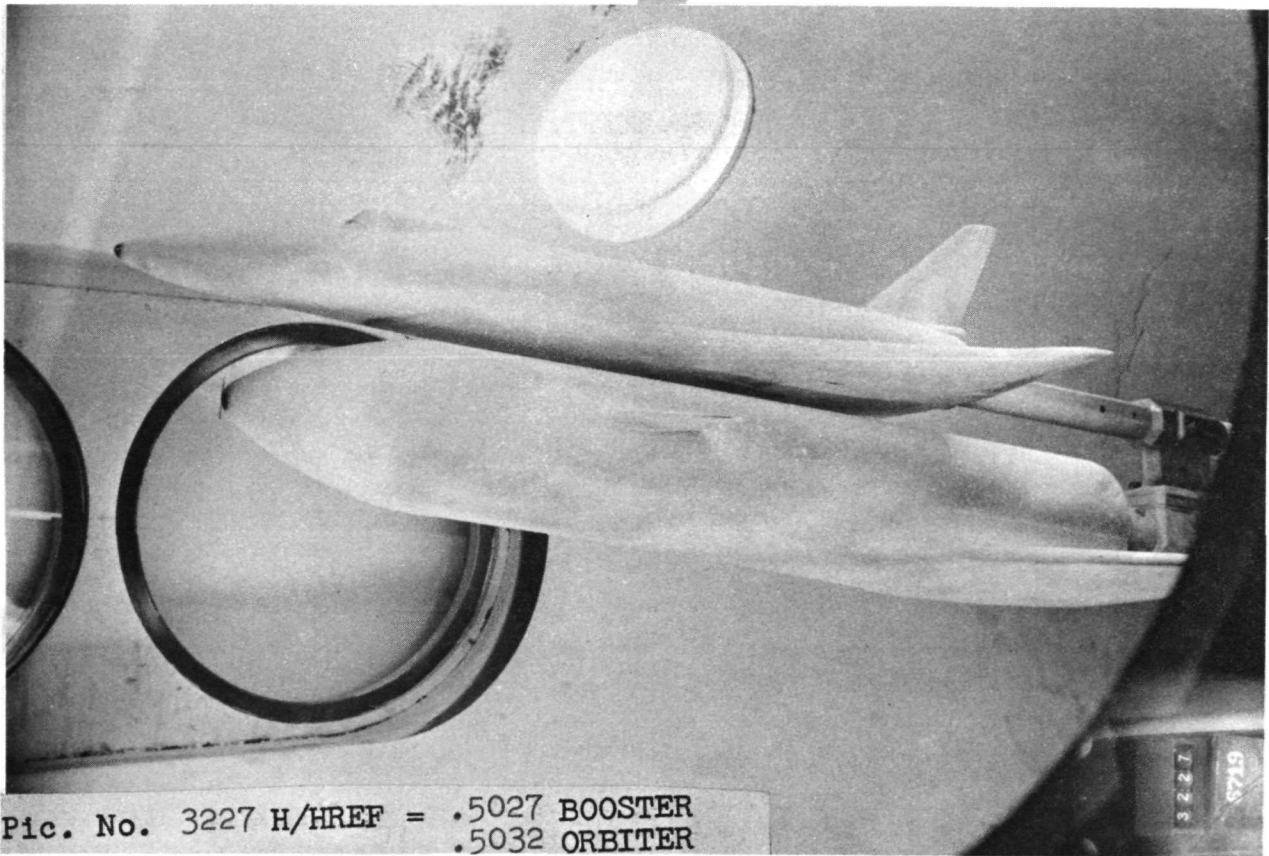

Pic. No. 3227 H/HREF = .5027 BOOSTER
.5032 ORBITER

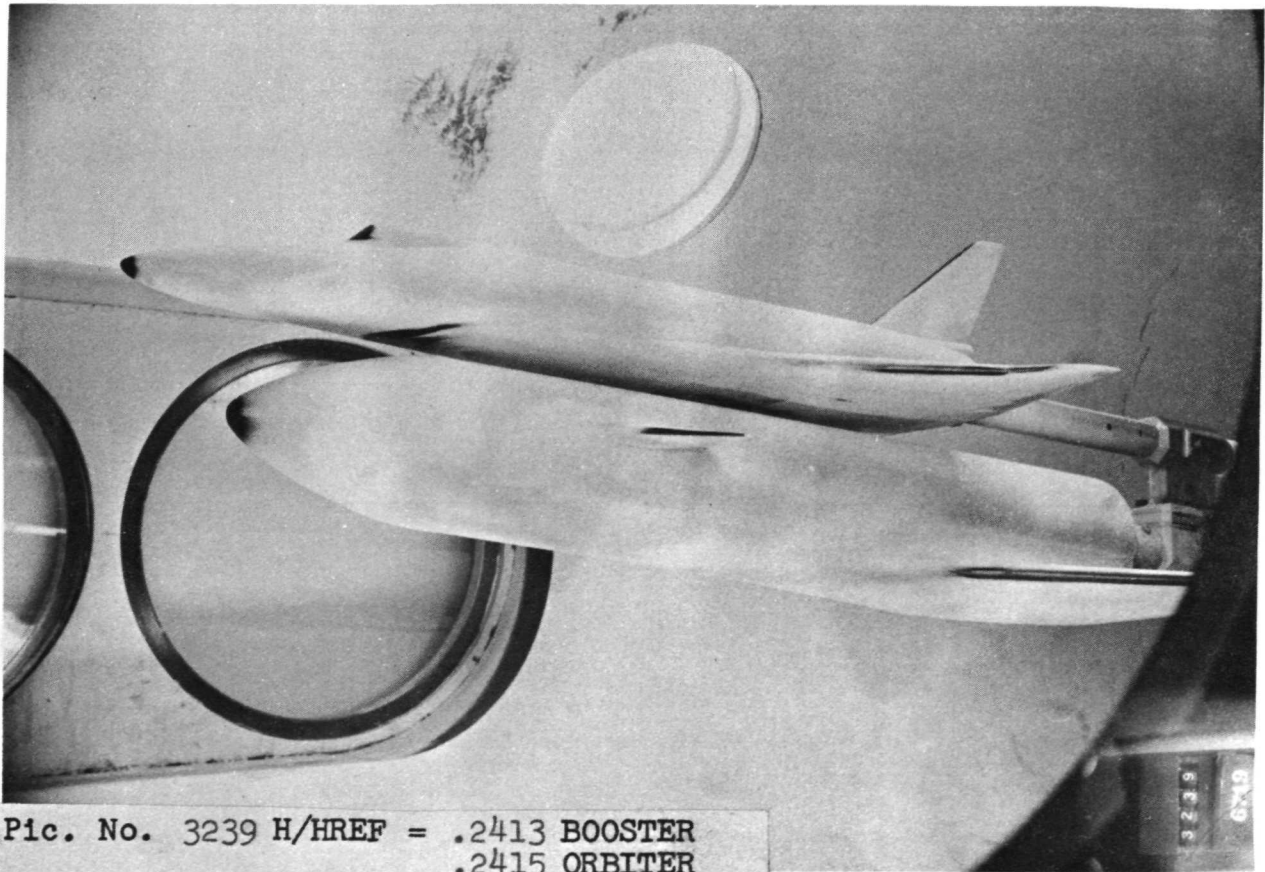

Pic. No. 3239 H/HREF = .2413 BOOSTER
.2415 ORBITER

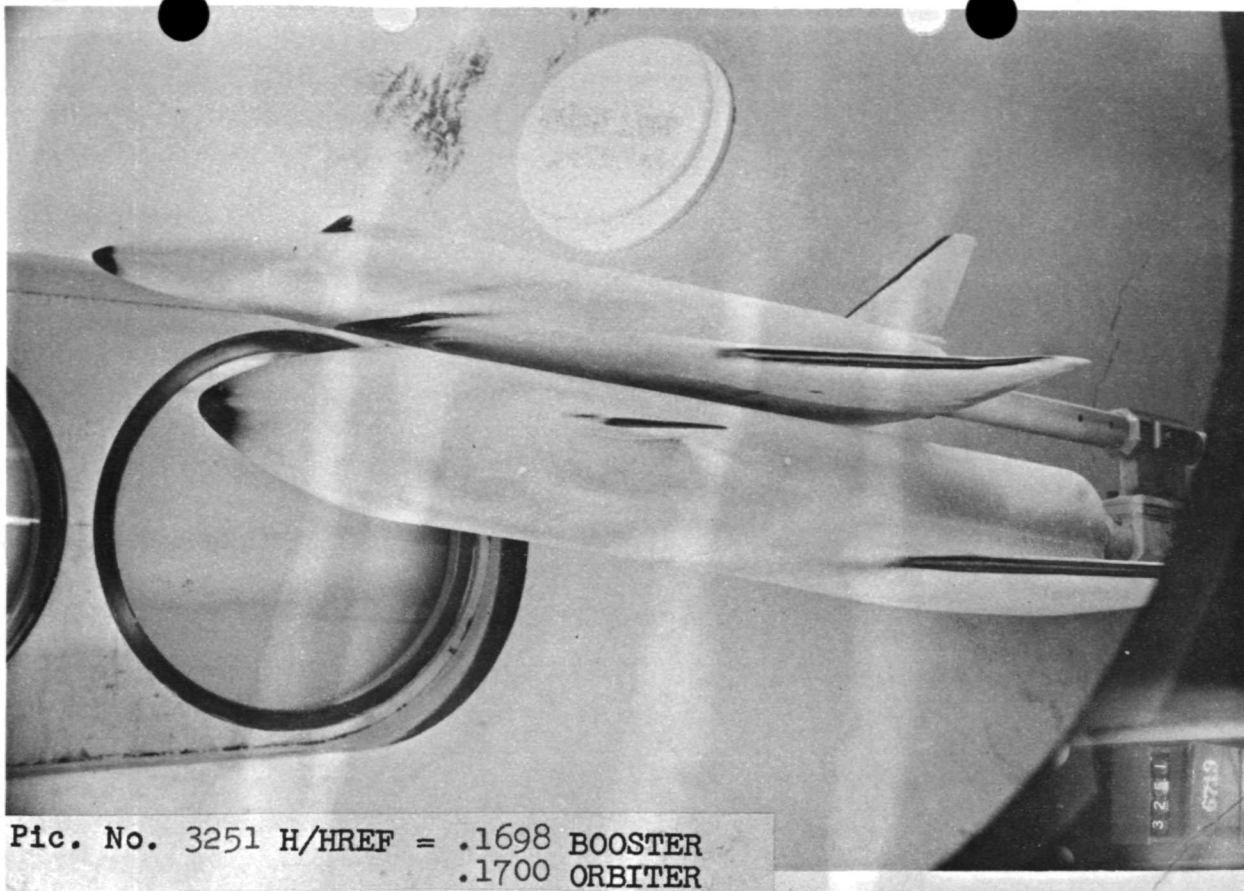

Pic. No. 3251 H/HREF = .1698 BOOSTER
.1700 ORBITER

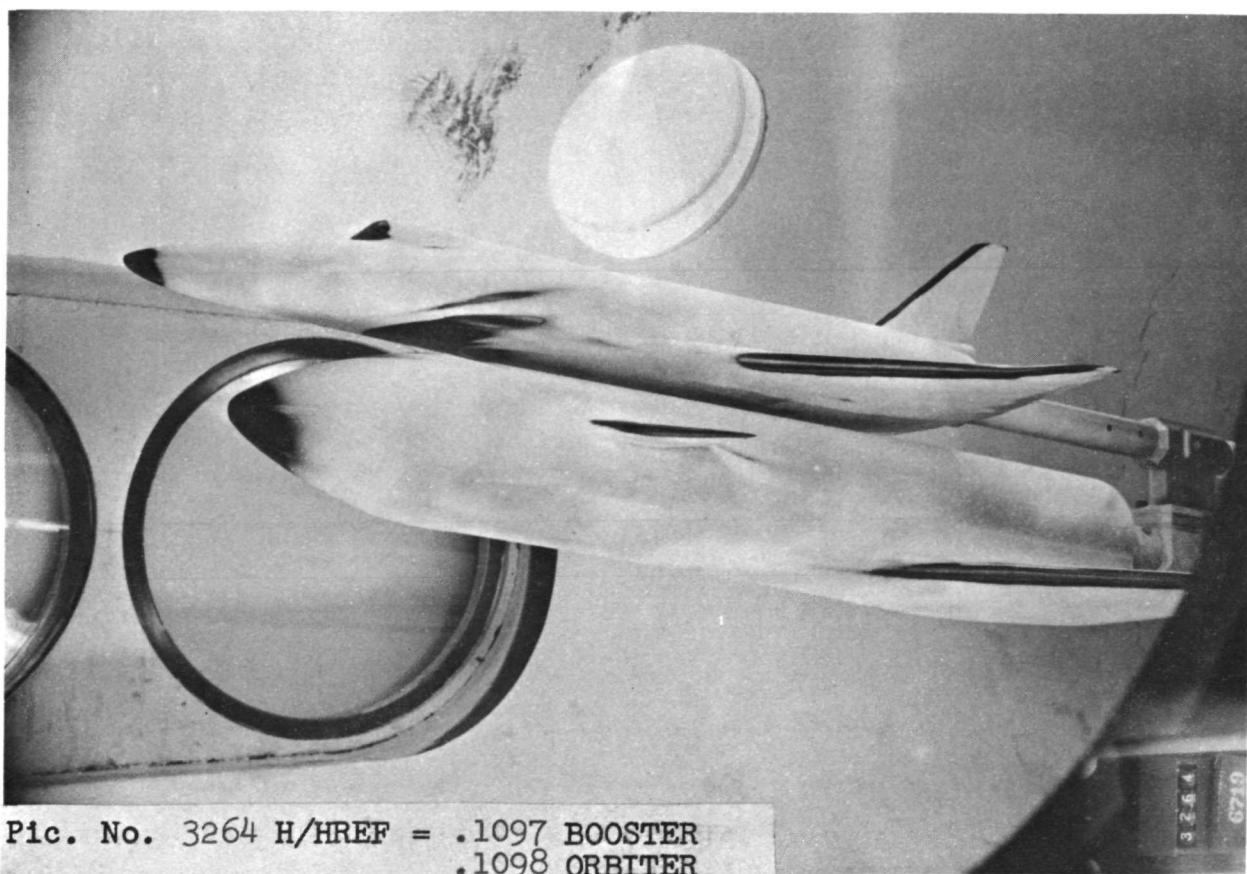

Pic. No. 3264 H/HREF = .1097 BOOSTER
.1098 ORBITER

6/ 4/71

ARNOLD INC. ARNOLD AFS, TENNESSEE
VON KARMAN GAS DYNAMICS FACILITY
50 INCH HYPERSONIC TUNNEL R
V11162

GROUP 229 CONFIG 6253 MODEL GDC-H*0W0 MACH NO 7.97 PO PSIA 265.3 TO DEG R 1266 ALPHA-MODEL 5.02 ALPHA-SECTOR 5.02 ALPHA-PREBEND 0 ROLL-MODEL 0 YAW 0

T-INF P-INF 0-TAF V-INF RHO-INF MU-INF RE/FT HREF STREF
(DEG R) (PSIA) (FT/SEC) (SLUGS/FT3) (LB-SEC/FT2) (FT-1) (R=.013FT) (R=.013FT)
92.4 .028 1.238 3754 2.529E-05 7.438E-08 1.28E 06 3.191E-02 4.194E-02

CAMERA PAINT FMP (DEG F) INITIAL TEMP (DEG F) SQUARE ROOT (RHOXCKX)
TOP(T) 125
ICE(US) 125 AVERAGE TW = 60 (R)
ICE(LS) 125 AVERAGE TW = 78 (C) -0.008(SQUARE ROOT DEL TIME) * 0.11

PIC NO	TMP DELTME	H(TO)	H(TO)/HREF	H(.910)	H(.910)/HREF	H(.8510)	H(.8510)/HREF	ST(TO)	MODEL	TEMP F
LS 3283 (125)	3.65	2.61	0.359E-03	.1125	4.395E-03	.1377	4.951E-03	.1552	4.729E-03	68 80 78
LS 3283 (125)	3.65	2.61	8.436E-03	.1366	5.336E-03	.1672	6.010E-03	.1883	5.743E-03	68 80 78
LS 3283 (125)	3.65	2.61	8.436E-03	.1366	5.336E-03	.1672	6.010E-03	.1883	5.743E-03	68 80 78
LS 3283 (125)	3.65	2.61	0.359E-03	.1125	4.395E-03	.1377	4.951E-03	.1552	4.729E-03	68 80 78
LS 3295 (125)	9.95	8.91	0.172E-03	.0540	2.110E-03	.0661	2.378E-03	.0745	2.271E-03	69 70 82 84
LS 3295 (125)	9.95	8.91	8.209E-03	.0656	2.563E-03	.0803	2.886E-03	.0904	2.758E-03	69 70 82 84
LS 3295 (125)	9.95	8.91	0.172E-03	.0540	2.110E-03	.0661	2.378E-03	.0745	2.271E-03	69 70 82 84
LS 3307 (125)	16.25	15.21	0.121E-03	.0378	1.478E-03	.0463	1.665E-03	.0522	1.589E-03	72 72 85 90
LS 3307 (125)	16.25	15.21	8.147E-03	.0459	1.795E-03	.0562	2.021E-03	.0633	1.930E-03	72 72 85 90
LS 3307 (125)	16.25	15.21	0.121E-03	.0378	1.478E-03	.0463	1.665E-03	.0522	1.589E-03	72 72 85 90
LS 3318 (125)	26.15	25.11	0.834E-04	.0261	1.021E-03	.0320	1.150E-03	.0360	1.098E-03	76 75 89 98
LS 3318 (125)	26.15	25.11	8.101E-03	.0317	1.239E-03	.0388	1.396E-03	.0437	1.333E-03	76 75 89 98
LS 3318 (125)	26.15	25.11	8.101E-03	.0317	1.239E-03	.0388	1.396E-03	.0437	1.333E-03	76 75 89 98
LS 3318 (125)	26.15	25.11	0.834E-04	.0261	1.021E-03	.0320	1.150E-03	.0360	1.098E-03	76 75 89 98

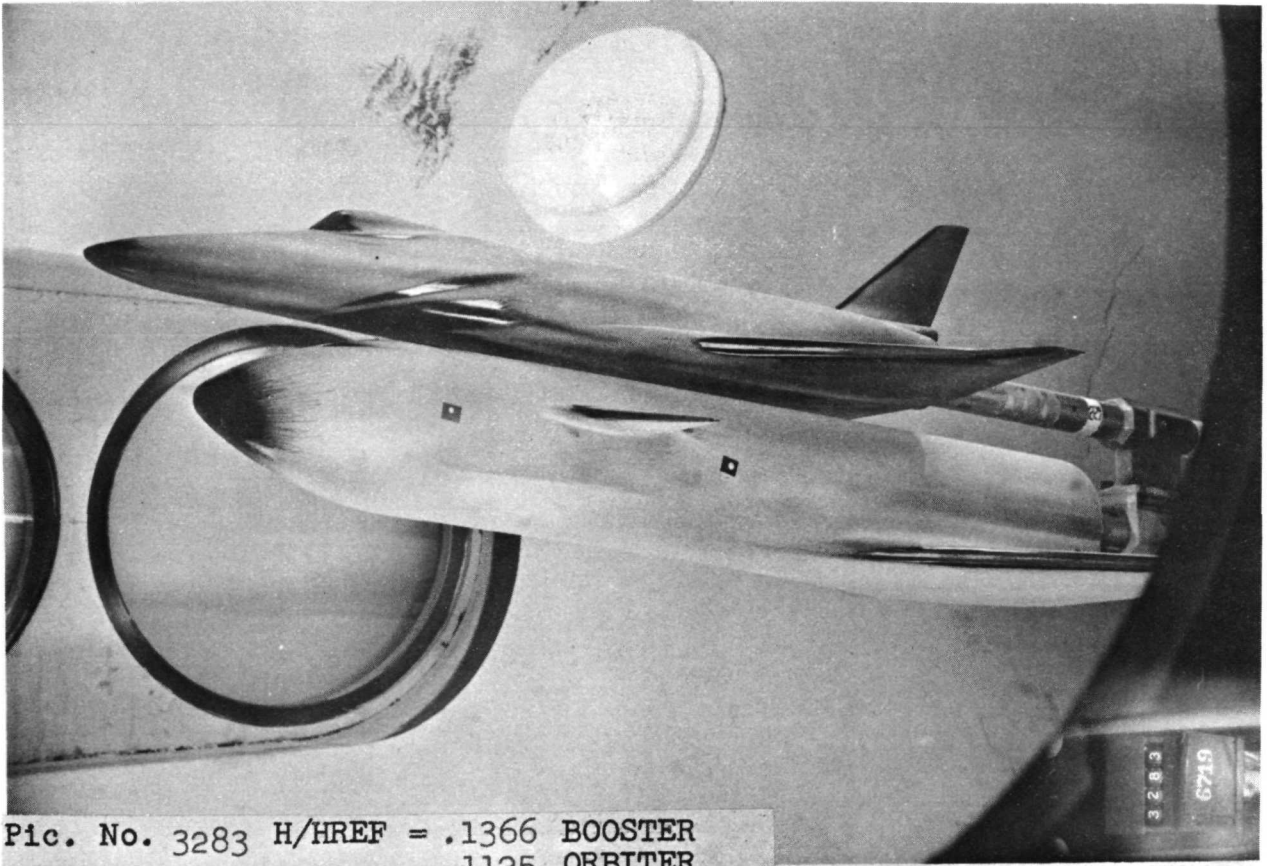

Pic. No. 3283 H/HREF = .1366 BOOSTER
.1125 ORBITER

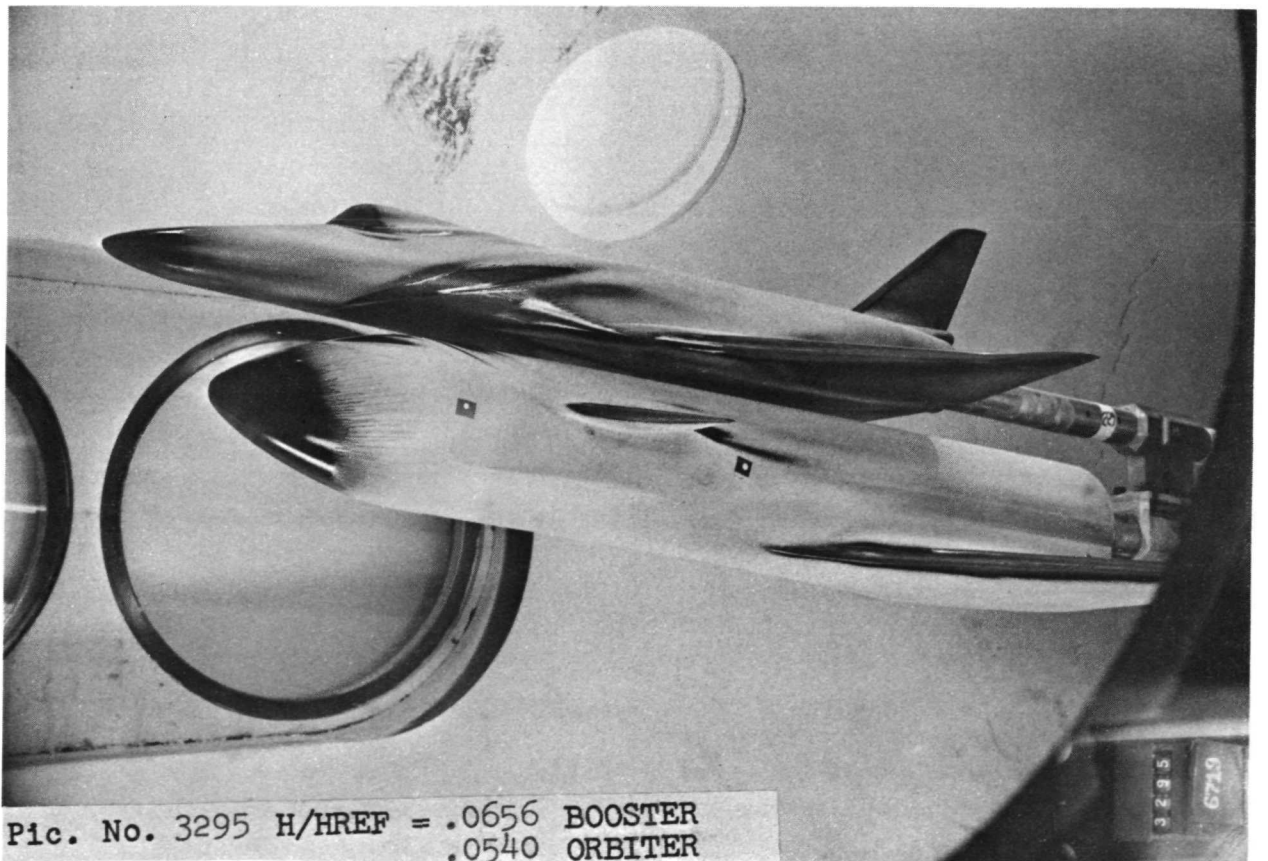

Pic. No. 3295 H/HREF = .0656 BOOSTER
.0540 ORBITER



Pic. No. 3307 H/HREF = .0459 BOOSTER
.0378 ORBITER

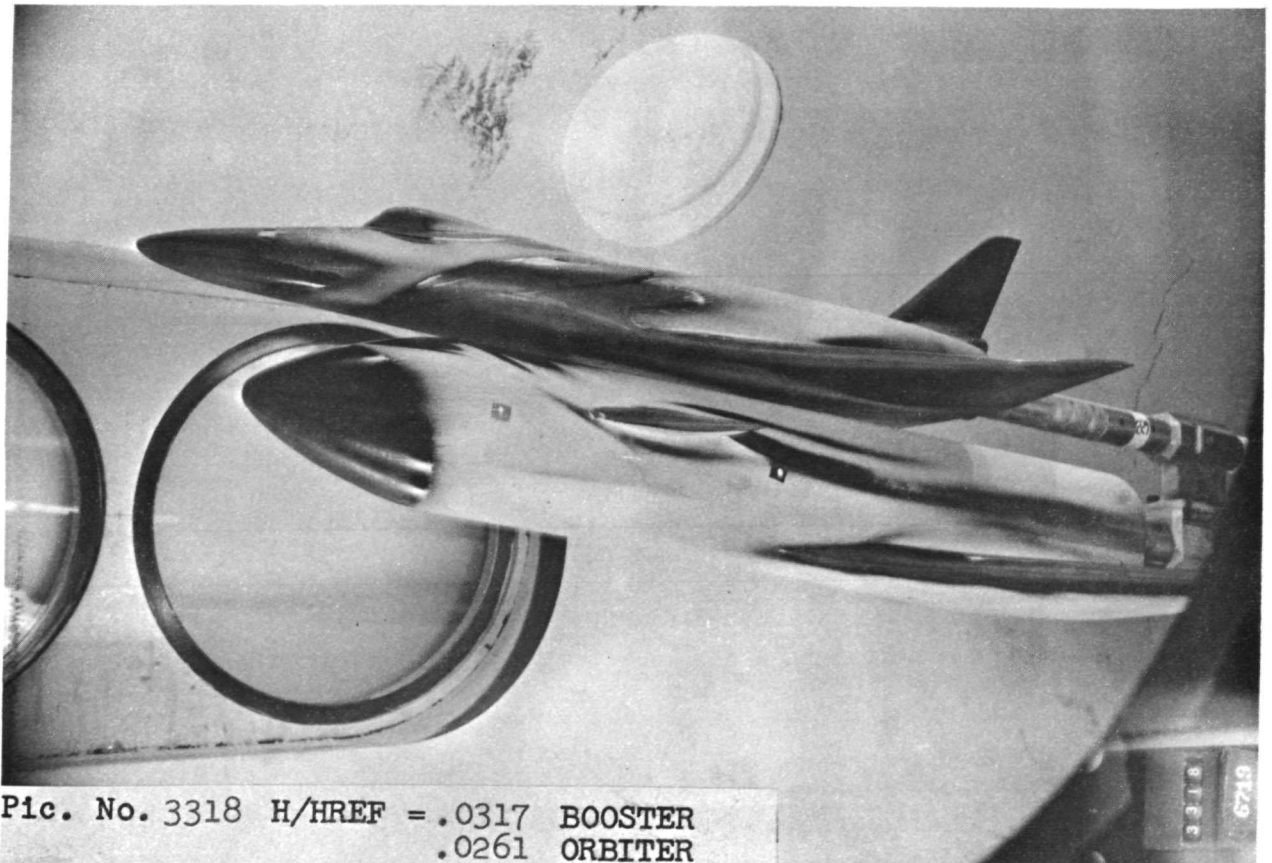

Pic. No. 3318 H/HREF = .0317 BOOSTER
.0261 ORBITER

6/ 4/71

AEDCIARD, INC.) ARNOLD AFS, TENNESSEE
VON KARMAN GAS DYNAMICS FACILITY
50 INCH HYPERSONIC TUNNEL R
V11162

GROUP 230 CONFIG 6153 MODEL EDC-H-O-WO MACH NO 7.97 PO PSTA 264.6 TO DEG R 1269 ALPHA-MODEL -4.99 ALPHA-SECTOR -4.99 ALPHA-PREBEND 0 ROLL-MODEL 0 YAW 0

T-1NF P-1NF Q-1NF V-1NF RHO-1NF MU-1NF RE/FT HREF STREF
(DFG R) (PSTIA) (PSTIA) (FI/SEC) (SLUGS/FT3) (LB-SEC/FT2) (FT-1) (R= .013FT) (R= .013FT) I
92.6 .028 1.235 378 2.517E-05 7.454E-08 1.27E-06 3.199E-02 4.205E-02

CAVEIRA PAINT TEMP (DEG F) INITIAL TEMP (DEG F) SQUARE ROOT (RHO/CXK)
TOP (I) 250
SIDE (US) 250 AVERAGE TW = 74 (R)
SIDE (LS) 250 AVERAGE TW = 82 (C) -.0081 SQUARE ROOT DEL TIME) * 0.1

PIC NO	TIME	DELTIME	H(TO)	H(TO)/HREF	H(.910)	H(.910)/HREF	H(.8510)	H(.8510)/HREF	ST(TO)	MODEL	TEMP F
LS 3330	(250)	3.65	2.58	0 1.57E-02	.4773	1.942E-02	.6091	2.254E-02	.7072	1.998E-02	74 74 84 83
LS 3330	(250)	3.65	2.58	R 1.59E-02	.4985	2.027E-02	.6359	2.353E-02	.7380	2.087E-02	74 74 84 83
LS 3330	(250)	3.65	2.58	B 1.59E-02	.4985	2.027E-02	.6359	2.353E-02	.7380	2.087E-02	74 74 84 83
LS 3330	(250)	3.65	2.58	O 1.52E-02	.4773	1.942E-02	.6091	2.254E-02	.7072	1.998E-02	74 74 84 83
LS 3342	(250)	9.95	8.88	O 7.28E-03	.2283	9.287E-03	.2913	1.078E-02	.3382	9.556E-03	76 74 87 96
LS 3342	(250)	9.95	8.88	R 7.60E-03	.2384	9.695E-03	.3042	1.125E-02	.3530	9.980E-03	76 74 87 96
LS 3342	(250)	9.95	8.88	B 7.60E-03	.2384	9.695E-03	.3042	1.125E-02	.3530	9.980E-03	76 74 87 96
LS 3342	(250)	9.95	8.88	O 7.28E-03	.2283	9.287E-03	.2913	1.078E-02	.3382	9.556E-03	76 74 87 96
LS 3354	(250)	16.30	15.23	O 5.08E-03	.1594	6.484E-03	.2034	7.528E-03	.2362	6.673E-03	78 76 91 108
LS 3354	(250)	16.30	15.23	R 5.31E-03	.1665	6.770E-03	.2124	7.856E-03	.2465	6.968E-03	78 76 91 108
LS 3354	(250)	16.30	15.23	B 5.31E-03	.1665	6.770E-03	.2124	7.856E-03	.2465	6.968E-03	78 76 91 108
LS 3354	(250)	16.30	15.23	O 5.09E-03	.1594	6.484E-03	.2034	7.528E-03	.2362	6.673E-03	78 76 91 108
LS 3365	(250)	26.25	25.18	O 3.50E-03	.1099	4.472E-03	.1463	5.192E-03	.1629	4.601E-03	80 79 95 121
LS 3365	(250)	26.25	25.18	R 3.66E-03	.1148	4.669E-03	.1465	5.418E-03	.1700	4.805E-03	80 79 95 121
LS 3365	(250)	26.25	25.18	B 3.66E-03	.1148	4.669E-03	.1465	5.418E-03	.1700	4.805E-03	80 79 95 121
LS 3365	(250)	26.25	25.18	O 3.50E-03	.1099	4.472E-03	.1463	5.192E-03	.1629	4.601E-03	80 79 95 121

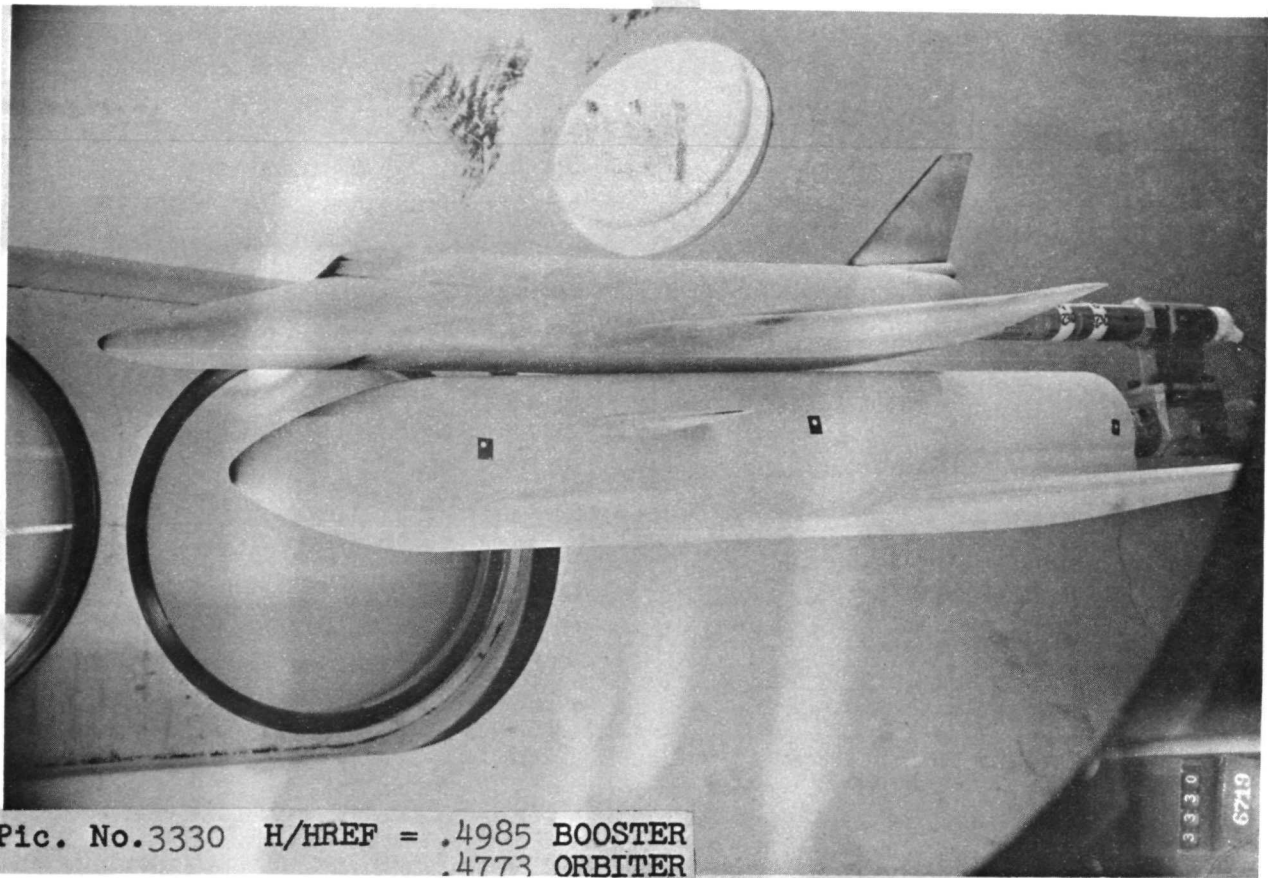

Pic. No. 3330 H/HREF = .4985 BOOSTER
.4773 ORBITER

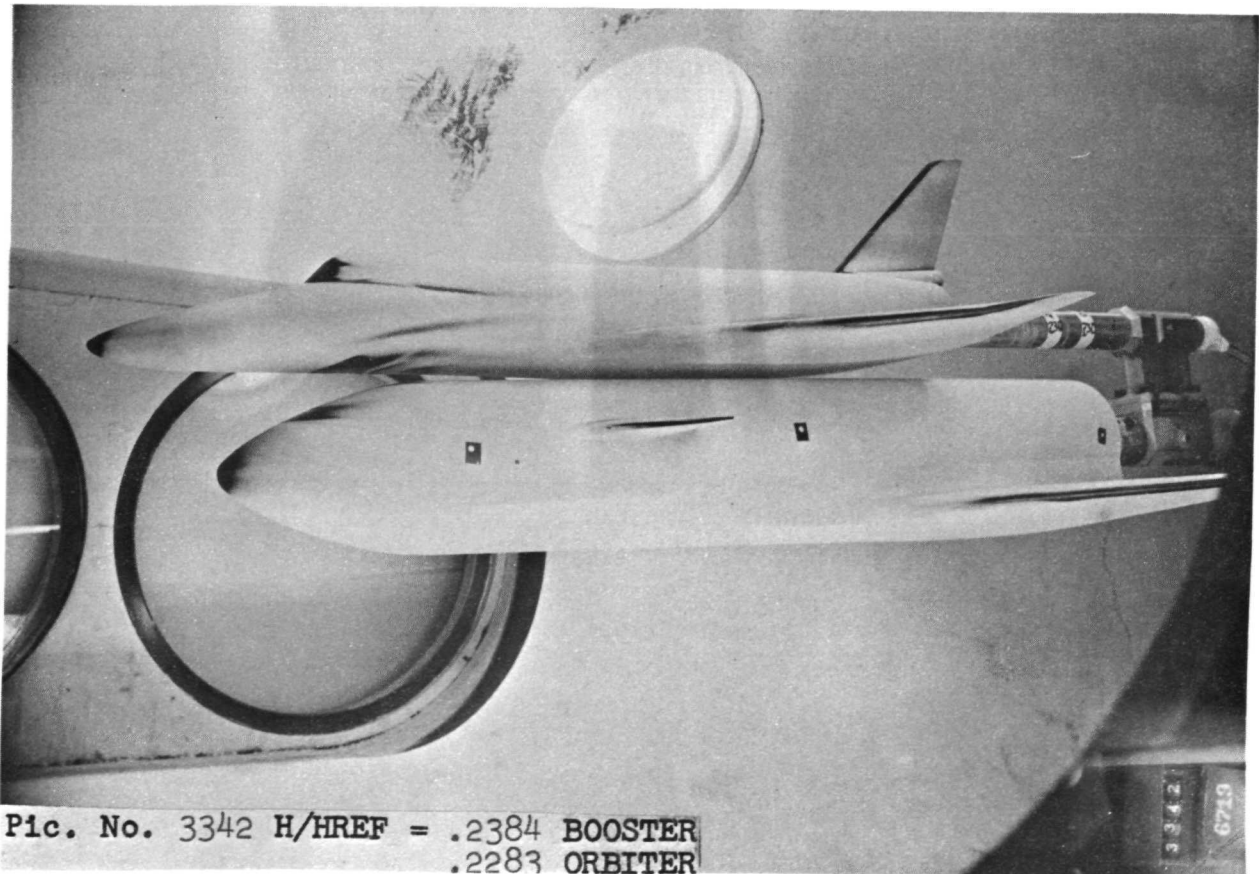

Pic. No. 3342 H/HREF = .2384 BOOSTER
.2283 ORBITER

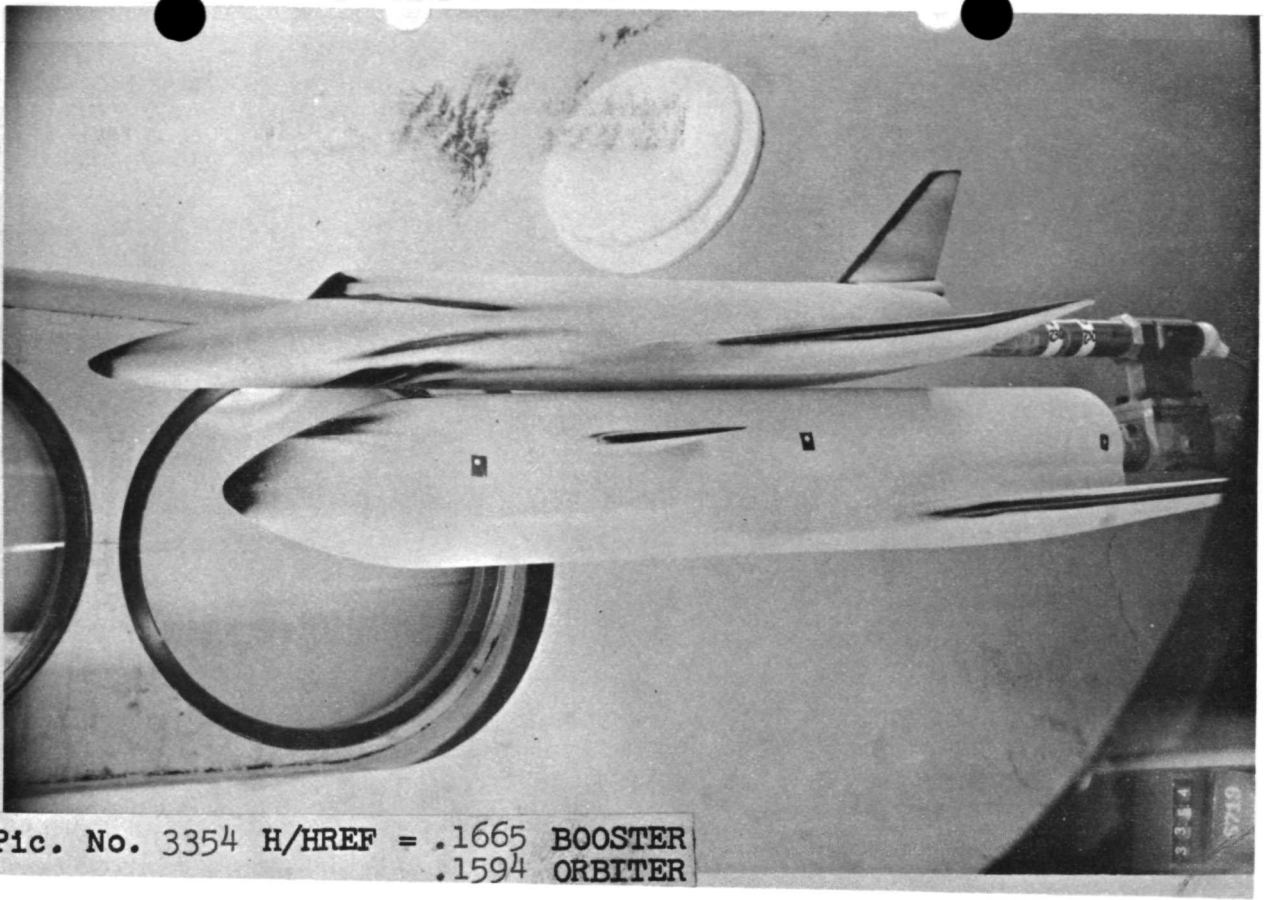

Pic. No. 3354 H/HREF = .1665 BOOSTER
.1594 ORBITER

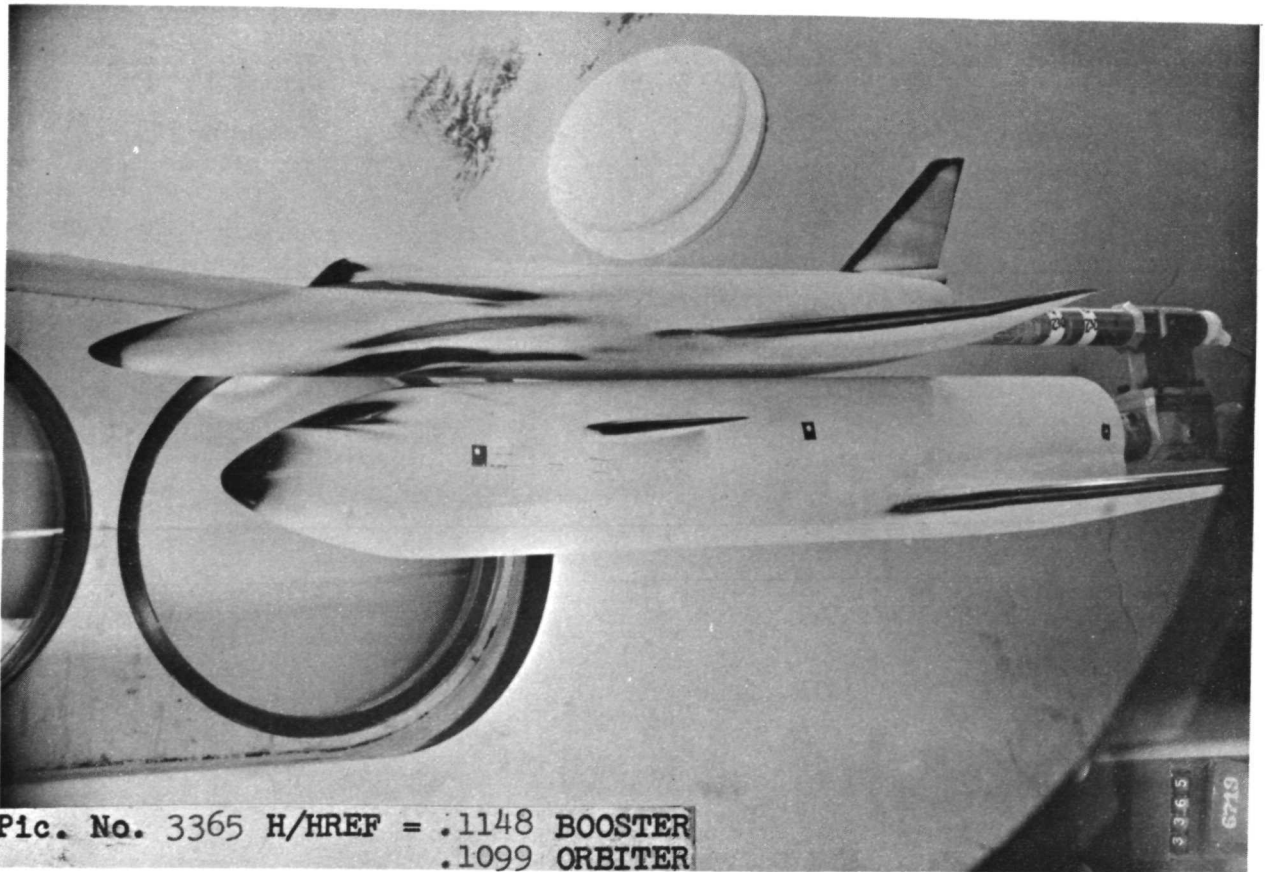

Pic. No. 3365 H/HREF = .1148 BOOSTER
.1099 ORBITER

6/ 4/71

AEDC(ARO,INC.) ARNOLD AFS, TENNESSEE
VON KARMAN GAS DYNAMICS FACILITY
50 INCH HYPERSONIC TUNNEL B
V11162

GROUP CONFIG MODEL MACH NO PO PSIA TO DEG R ALPHA-WOVEL ALPHA-SECTOR ALPHA-PREBEND ROLL-MODEL YAW
231 6253 6DC-R*0*0 7.97 262.5 1270 -5.00 -5.00 0 0

T-INF P-INF Q-INF V-INF RHO-INF MU-INF RE/FT HREF STREF
(DEG R) (PSIA) (PSIA) (FT/SEC) (SLUGS/FT3) (LB-SEC/FT2) (FT-1) (R=.013FT) (R=.013FT)
92.7 .028 1.225 3760 2.494E-05 7.463E-08 1.26E 06 3.161E-02 4.225E-02

CAMERA PAINT TEMP (DEG F) INITIAL TEMP (DEG F) SQUARE ROOT (RHOXCKX)
TOP(T) 125 AVERAGE TM = 71 (R)
SIDE(U) 125 AVERAGE TW = 85 (O)
SIDE(L) 125

PIC NC	TIME DELTIME	H(TO)	H(TO)/HREF	H(.91TO)	H(.91TO)/HREF	H(.85TO)	H(.85TO)/HREF	ST(TO)	MODEL	TEMP F
LS 3376 (125)	3.65	2.58	0.309E-03	.0972	3.778E-03	.1190	4.255E-03	.1340	4.114E-03	70 87 85
LS 3376 (125)	3.65	2.58	8.419E-03	.1318	5.120E-03	.1612	5.763E-03	.1815	5.580E-03	70 87 85
LS 3376 (125)	3.65	2.58	8.419E-03	.1318	5.120E-03	.1612	5.763E-03	.1815	5.580E-03	70 87 85
LS 3376 (125)	3.65	2.58	0.309E-03	.0972	3.778E-03	.1190	4.255E-03	.1340	4.114E-03	70 87 85
LS 3389 (125)	10.50	9.43	0.142E-03	.0447	1.739E-03	.0548	1.958E-03	.0617	1.894E-03	71 91 98
LS 3389 (125)	10.50	9.43	8.1193E-03	.0507	2.356E-03	.0742	2.652E-03	.0835	2.569E-03	71 91 98
LS 3389 (125)	10.50	9.43	8.1193E-03	.0507	2.356E-03	.0742	2.652E-03	.0835	2.569E-03	71 91 98
LS 3389 (125)	10.50	9.43	0.142E-03	.0447	1.739E-03	.0548	1.958E-03	.0617	1.894E-03	71 91 98
LS 3401 (125)	16.85	15.78	0.101E-03	.0317	1.231E-03	.0387	1.386E-03	.0436	1.340E-03	73 94 109
LS 3401 (125)	16.85	15.78	8.1136E-03	.0429	1.668E-03	.0525	1.877E-03	.0591	1.818E-03	73 94 109
LS 3401 (125)	16.85	15.78	8.1136E-03	.0429	1.668E-03	.0525	1.877E-03	.0591	1.818E-03	73 94 109
LS 3401 (125)	16.85	15.78	0.101E-03	.0317	1.231E-03	.0387	1.386E-03	.0436	1.340E-03	73 94 109
LS 3411 (125)	23.60	22.53	0.775E-04	.0244	9.485E-04	.0299	1.068E-03	.0336	1.034E-03	75 98 120
LS 3411 (125)	23.60	22.53	8.105E-03	.0331	1.285E-03	.0405	1.447E-03	.0456	1.402E-03	75 98 120
LS 3411 (125)	23.60	22.53	8.105E-03	.0331	1.285E-03	.0405	1.447E-03	.0456	1.402E-03	75 98 120
LS 3411 (125)	23.60	22.53	0.775E-04	.0244	9.485E-04	.0299	1.068E-03	.0336	1.034E-03	75 98 120

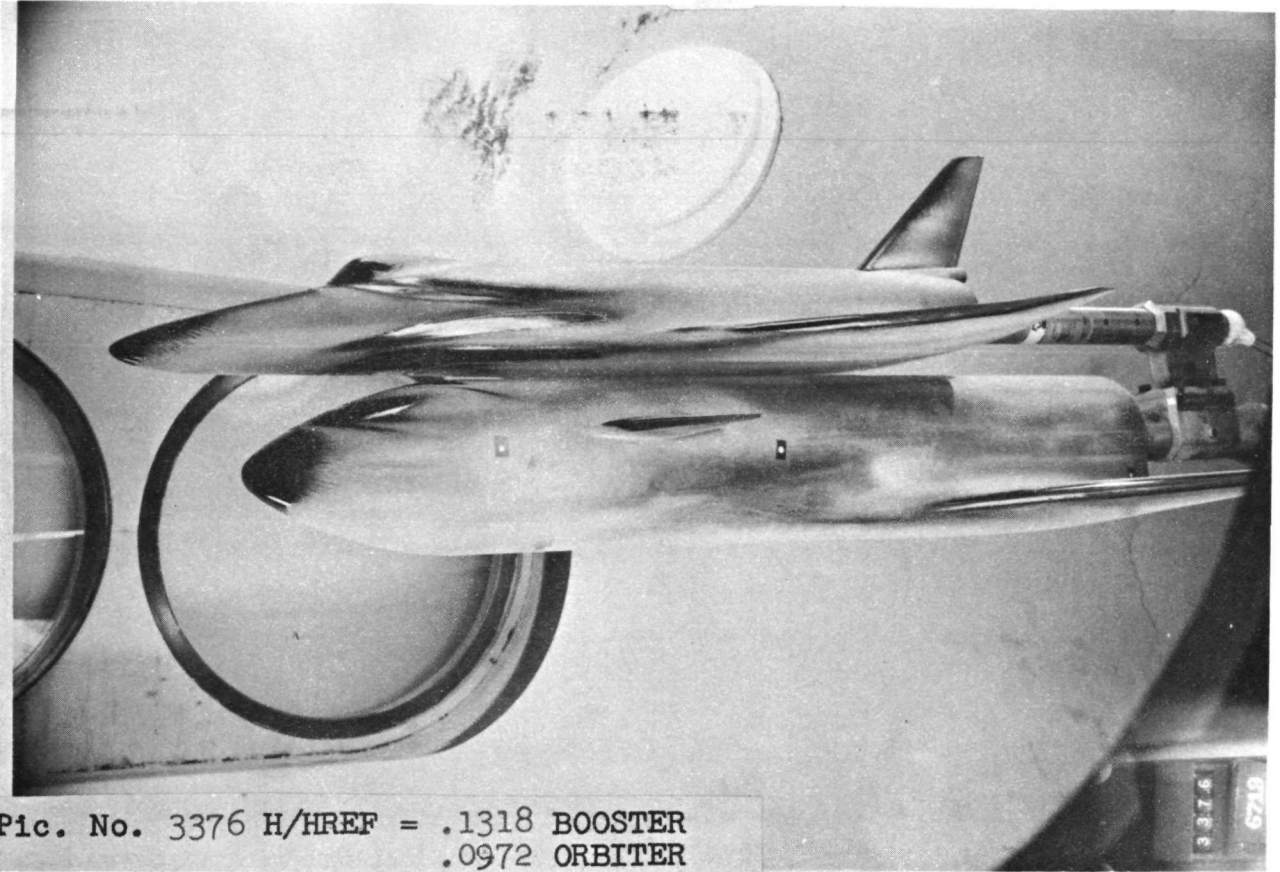

Pic. No. 3376 H/HREF = .1318 BOOSTER
.0972 ORBITER

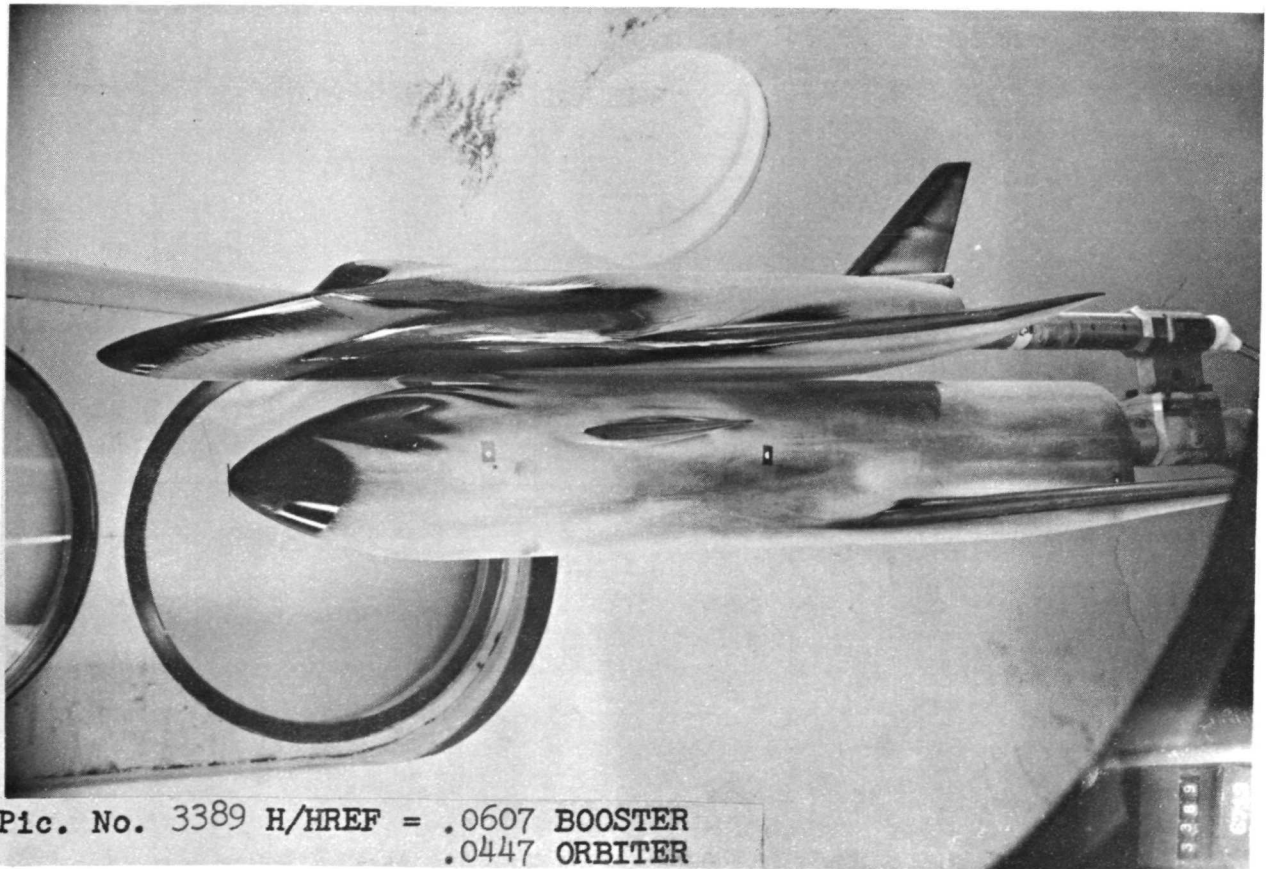

Pic. No. 3389 H/HREF = .0607 BOOSTER
.0447 ORBITER

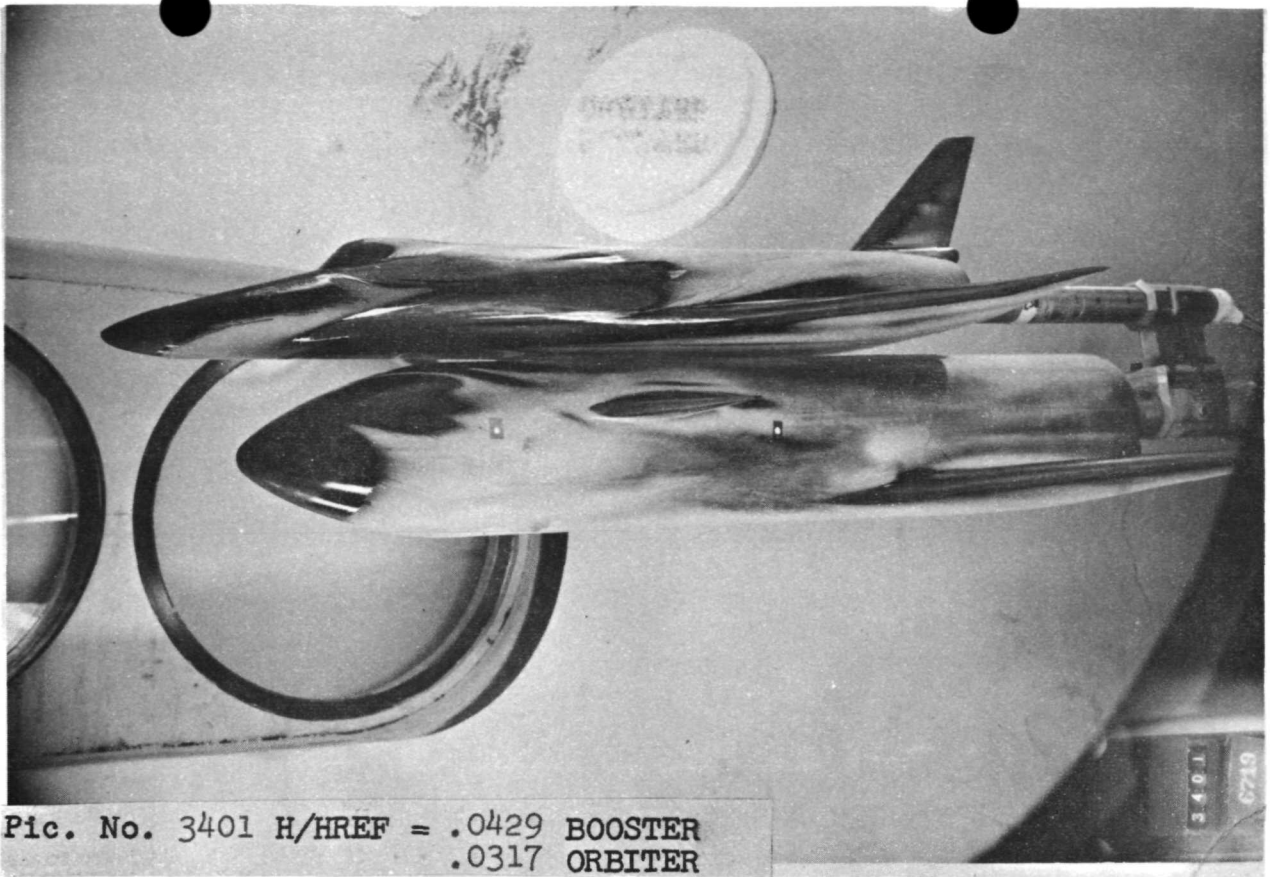

Pic. No. 3401 H/HREF = .0429 BOOSTER
.0317 ORBITER

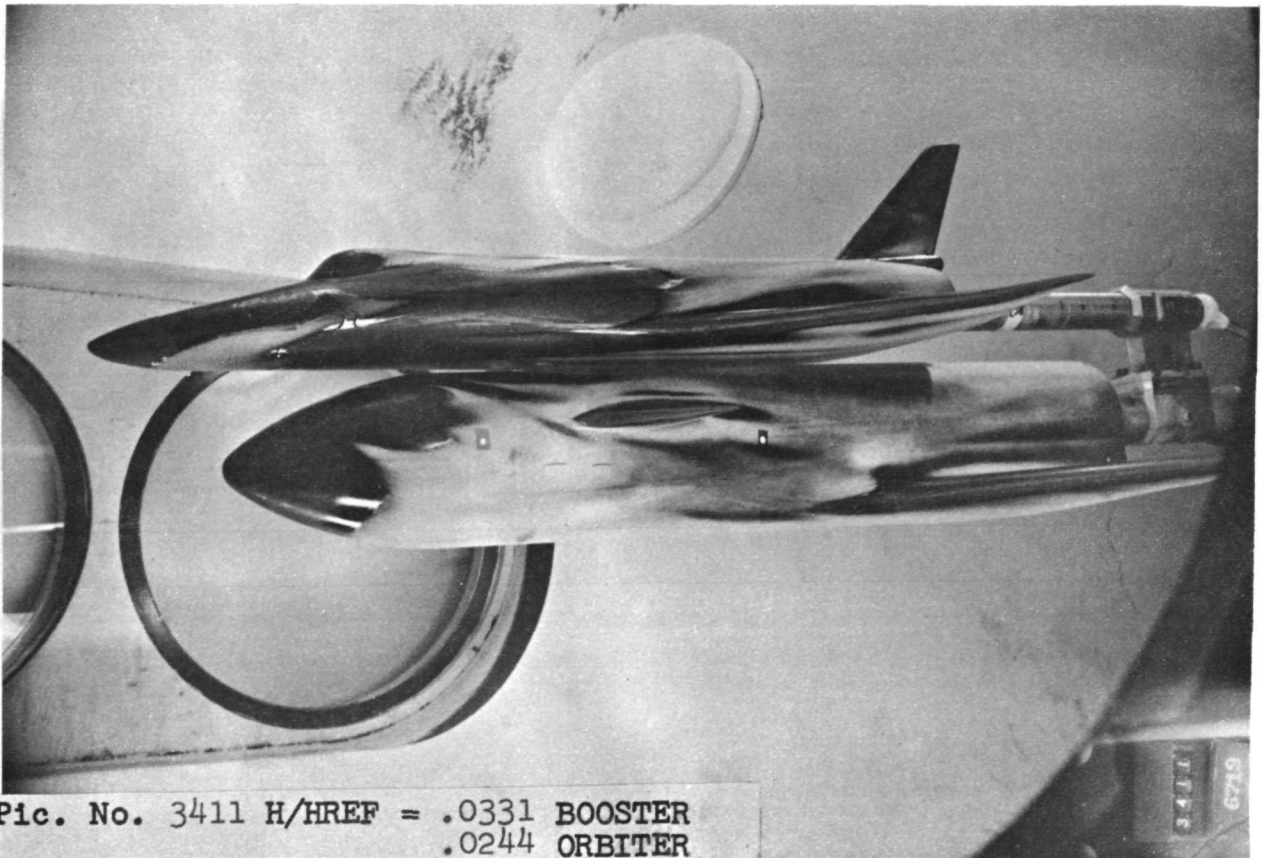

Pic. No. 3411 H/HREF = .0331 BOOSTER
.0244 ORBITER

6/ 4/71

AEDC(ARO,INC.) ARNOLD AFS, TENNESSEE
VON KARMAN GAS DYNAMICS FACILITY
50 INCH HYPERSONIC TUNNEL B
V11162

GROUP 239 COMFIG 6153 MODEL EDC-8+CWD MACH NO 8.00 PO PSIA 565.1 TO DEG R 1321 ALPHA-MODEL .02 ALPHA-SECTOR .02 ALPHA-PREBEND 0 ROLL-MODEL 0 YAW 0

T-INF P-INF O-INF V-INF RHO-INF MU-INF RE/FT HREF STREF
(DEG R) (PSIA) (PSIA) (FT/SEC) (SLUSS/FT3) (LB-SEC/FT2) (FT-1) (R=.013FT) (R=.013FT)
95.7 .058 2.593 3835 5.075E-05 7.794E-08 2.53E 06 4.655E-02 2.974E-02

CAMERA PAINT IFMP (DEG F) INITIAL TEMP (DEG F) SQUARE ROOT (RHOXCXK)
TOP(T) 275
SIDE(US) 275 AVERAGE TW = 75 (8)
SIDE(LS) 275 AVERAGE TW = 96 (10) -.0081(SQUARE ROOT DEL TIME) * 0.11

PIC NC	TIME DELTIME	H(TO)	H(TO)/HREF	H(.91TO)	H(.91TO)/HREF	H(.85TO)	H(.85TO)/HREF	ST(TO)	MODEL TEMP F				
LS 3706 (275)	3.65	2.58	0 1.55E-02	.3335	1.975E-02	.4247	2.289E-02	.4924	9.865E-03	0	75	96	98
LS 3706 (275)	3.65	2.58	8 1.72E-02	.3701	2.189E-02	.4709	2.535E-02	.5454	1.095E-02	0	75	96	98
LS 3706 (275)	3.65	2.58	8 1.72E-02	.3701	2.189E-02	.4709	2.535E-02	.5454	1.095E-02	0	75	96	98
LS 3706 (275)	3.65	2.58	0 1.55E-02	.3335	1.975E-02	.4247	2.289E-02	.4924	9.865E-03	0	75	96	98
LS 3717 (275)	9.30	8.23	0 7.79E-03	.1676	9.911E-03	.2134	1.149E-02	.2474	4.962E-03	0	75	98	108
LS 3717 (275)	9.30	8.23	8 8.63E-03	.1859	1.099E-02	.2366	1.273E-02	.2740	5.505E-03	0	75	98	108
LS 3717 (275)	9.30	8.23	8 8.63E-03	.1859	1.099E-02	.2366	1.273E-02	.2740	5.505E-03	0	75	98	108
LS 3717 (275)	9.30	8.23	0 7.79E-03	.1676	9.911E-03	.2134	1.149E-02	.2474	4.962E-03	0	75	98	108
LS 3728 (275)	15.05	13.98	0 5.49E-03	.1183	6.997E-03	.1506	8.111E-03	.1746	3.501E-03	0	77	101	118
LS 3728 (275)	15.05	13.98	8 6.10E-03	.1312	7.756E-03	.1670	8.984E-03	.1934	3.885E-03	0	77	101	118
LS 3728 (275)	15.05	13.98	8 6.10E-03	.1312	7.756E-03	.1670	8.984E-03	.1934	3.885E-03	0	77	101	118
LS 3728 (275)	15.05	13.98	0 5.49E-03	.1183	6.997E-03	.1506	8.111E-03	.1746	3.501E-03	0	77	101	118
LS 3739 (275)	23.40	22.31	0 3.92E-03	.0843	4.991E-03	.1074	5.785E-03	.1245	2.496E-03	0	80	105	131
LS 3739 (275)	23.40	22.31	8 4.35E-03	.0935	5.533E-03	.1190	6.409E-03	.1379	2.769E-03	0	80	105	131
LS 3739 (275)	23.40	22.31	8 4.35E-03	.0935	5.533E-03	.1190	6.409E-03	.1379	2.769E-03	0	80	105	131
LS 3739 (275)	23.40	22.31	0 3.92E-03	.0843	4.991E-03	.1074	5.785E-03	.1245	2.496E-03	0	80	105	131

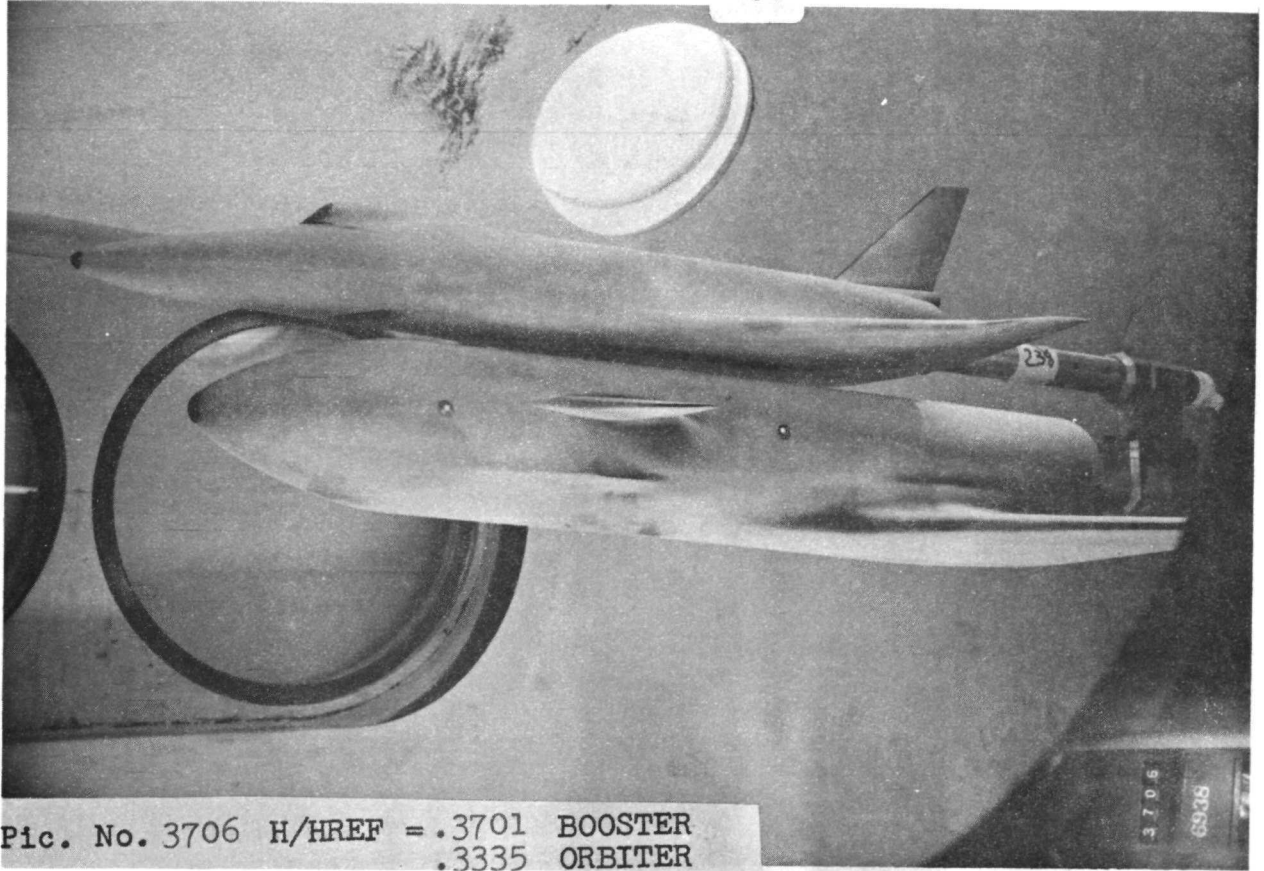

Pic. No. 3706 H/HREF = .3701 BOOSTER
.3335 ORBITER

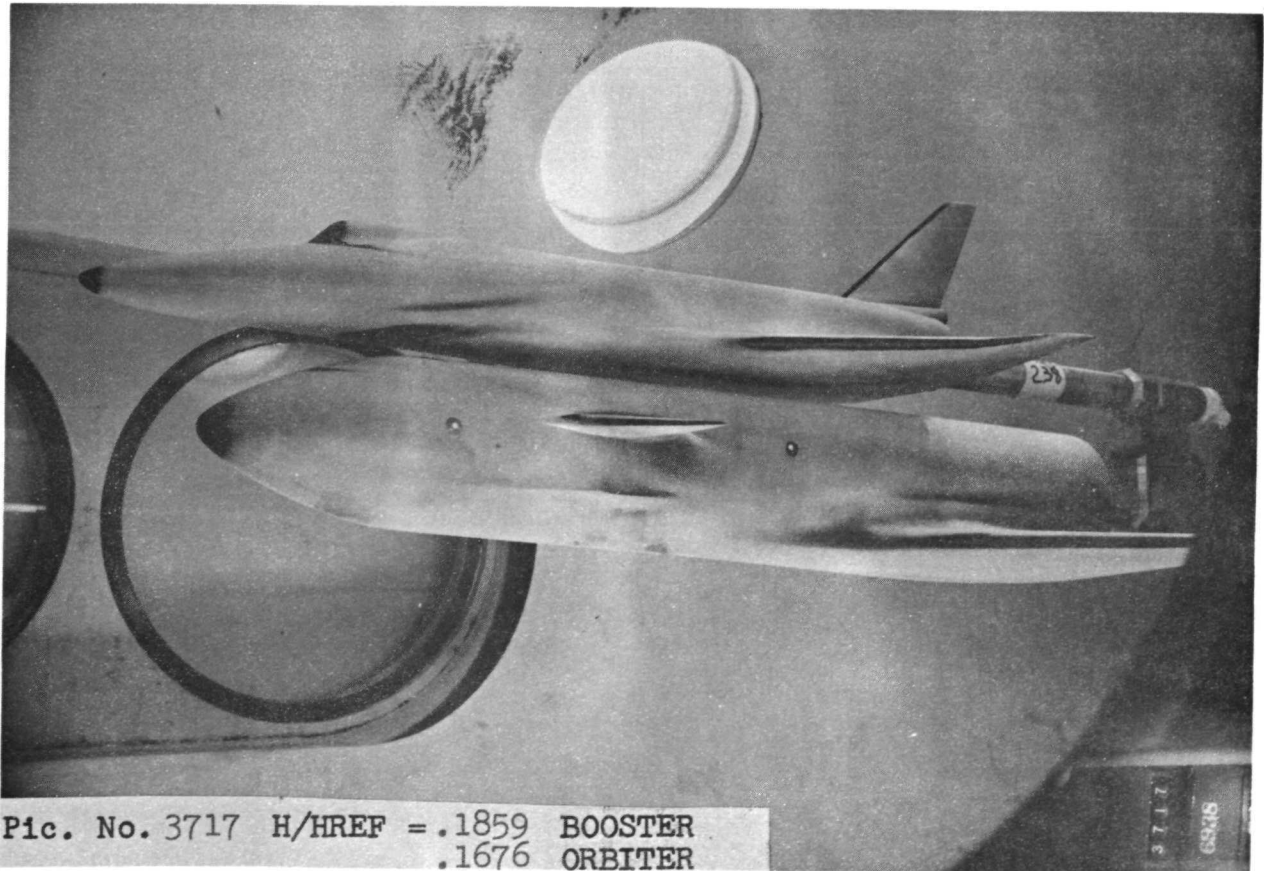

Pic. No. 3717 H/HREF = .1859 BOOSTER
.1676 ORBITER

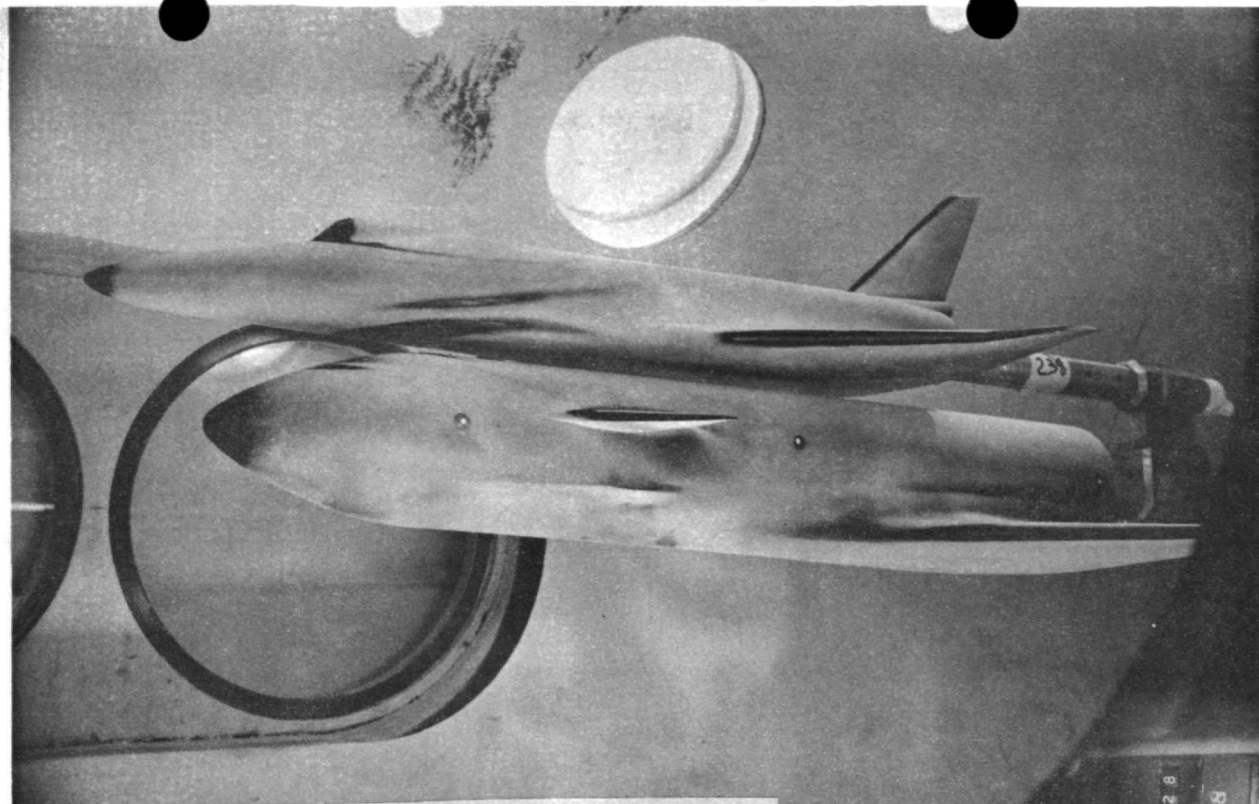

Pic. No. 3728 H/HREF = .1312 BOOSTER
.1183 ORBITER

3728
6938

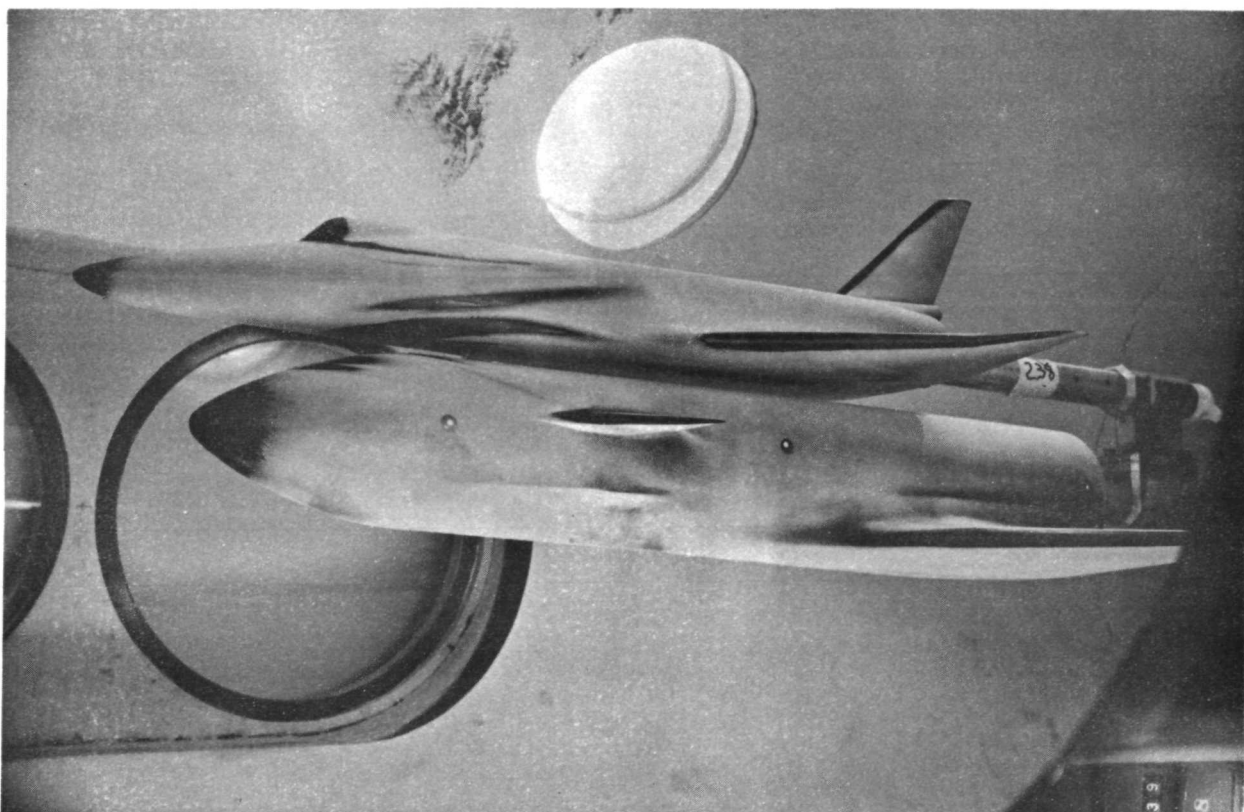

Pic. No. 3739 H/HREF = .0935 BOOSTER
.0843 ORBITER

3739
6938

6/ 4/71

AEDCLARO, INC.) ARNOLD AFS, TENNESSEE
VON KARMAN GAS DYNAMICS FACILITY
50 INCH HYPERSONIC TUNNEL B
VT11162

GROUP CONFIG MODEL MACH NO PO PSIA TO DEG R ALPHA-MODEL ALPHA-SECTOR ALPHA-PREPEND ROLL-MODEL YAW
239 6253 GDC-B*DW0 R.00 565.9 1316 .02 .02 0 0 0

T-INF P-INF G-INF V-INF RHO-INF MU-INF RE/FT HRF STREF
(DEG R) (PSIA) (PSIA) (FT/SEC) (SLUGS/FT3) (LB-SEC/FT2) (FT-1) (R=.013FT) (H=.013FT)
95.3 .058 2.597 382R 5.101E-05 7.676E-08 2.54E 06 4.649E-02 2.965E-02

PAINT TEMP (DEG F) INITIAL TEMP (DEG F) SQUARE ROOT (RHODCKK)
TOP(T) 150 AVERAGE TW = 75 (R) - .000(SQUARE ROOT DEL TIME) + 0.11
SIDE(LS) 150 AVERAGE TW = 95 (O)

PLC NO	TIME DELTIME	H(TO)	H(TO)/HREF	H(.910)	H(.910)/HREF	H(.8510)	H(.8510)/HREF	ST(TO)	MODEL TEMP F
LS 3757 (150)	3.65	2.5R	0	4.09E-03	.0879	5.006E-03	.1076	5.642E-03	1213
LS 3757 (150)	3.65	2.5R	R	5.55E-03	.1192	6.784E-03	.1459	7.638E-03	1642
LS 3757 (150)	3.65	2.5R	R	5.55E-03	.1192	6.784E-03	.1459	7.638E-03	1642
LS 3757 (150)	3.65	2.5R	0	4.09E-03	.0879	5.006E-03	.1076	5.642E-03	1213
LS 3770 (150)	10.35	9.2R	0	1.90E-03	.0408	2.328E-03	.0500	2.624E-03	0564
LS 3770 (150)	10.35	9.2R	R	2.58E-03	.0554	3.154E-03	.0678	3.551E-03	0763
LS 3770 (150)	10.35	9.2R	R	2.58E-03	.0554	3.154E-03	.0678	3.551E-03	0763
LS 3770 (150)	10.35	9.2R	0	1.90E-03	.0408	2.328E-03	.0500	2.624E-03	0564
LS 3783 (150)	17.10	16.03	0	1.32E-03	.0283	1.613E-03	.0347	1.818E-03	.0391
LS 3783 (150)	17.10	16.03	R	1.79E-03	.0384	2.185E-03	.0470	2.461E-03	.0529
LS 3783 (150)	17.10	16.03	R	1.79E-03	.0384	2.185E-03	.0470	2.461E-03	.0529
LS 3783 (150)	17.10	16.03	0	1.32E-03	.0283	1.613E-03	.0347	1.818E-03	.0391
LS 3797 (150)	30.94	29.87	0	8.20E-04	.0176	1.004E-03	.0216	1.132E-03	.0244
LS 3797 (150)	30.94	29.87	R	1.11E-03	.0239	1.361E-03	.0293	1.532E-03	.0330
LS 3797 (150)	30.94	29.87	R	1.11E-03	.0239	1.361E-03	.0293	1.532E-03	.0330
LS 3797 (150)	30.94	29.87	0	8.20E-04	.0176	1.004E-03	.0216	1.132E-03	.0244

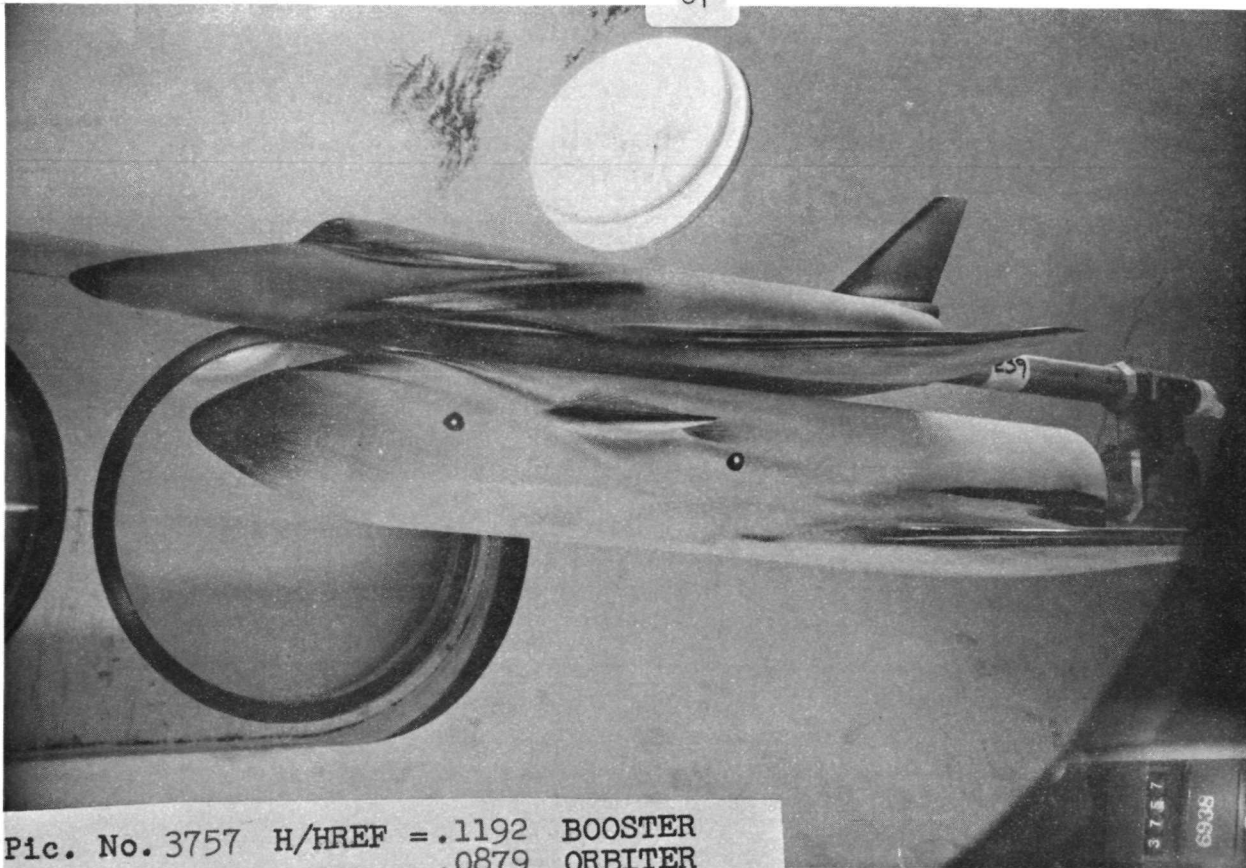

Pic. No. 3757 H/HREF = .1192 .0879 BOOSTER ORBITER

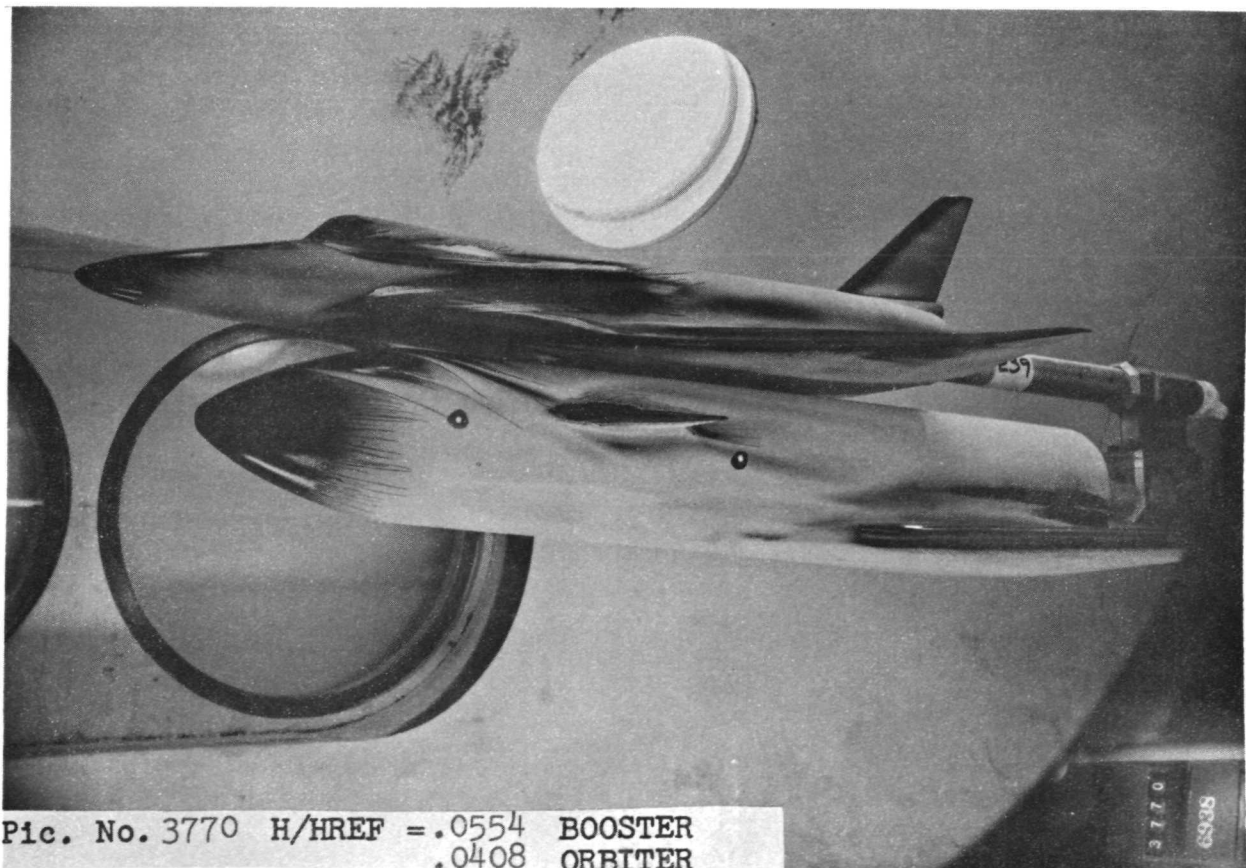

Pic. No. 3770 H/HREF = .0554 .0408 BOOSTER ORBITER

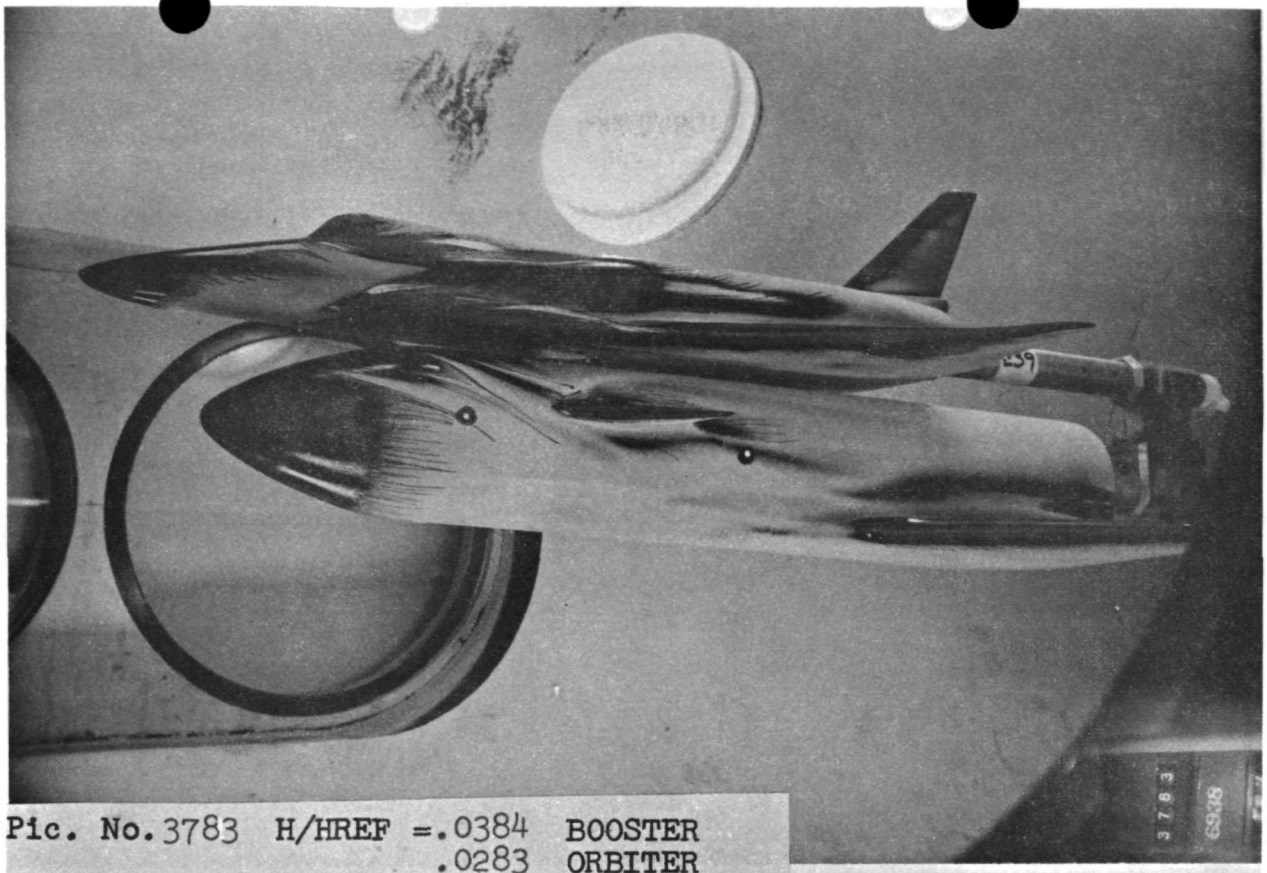

Pic. No. 3783 H/HREF = .0384 BOOSTER
.0283 ORBITER

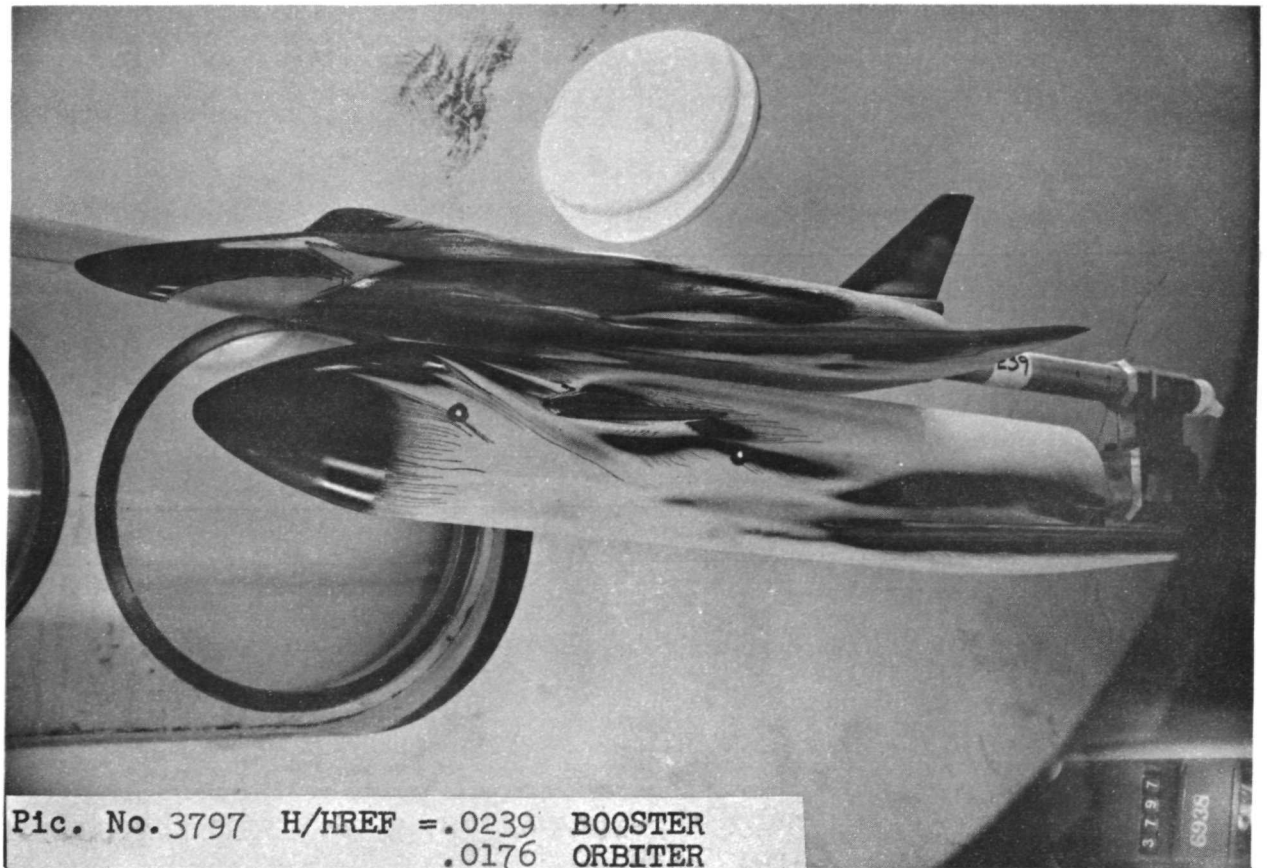

Pic. No. 3797 H/HREF = .0239 BOOSTER
.0176 ORBITER

6/ 4/71

AEDC(ARO,INC.) ARNOLD AFS, TENNESSEE
VON KARMAN GAS DYNAMICS FACILITY
50 INCH HYPERSONIC TUNNEL R
V71162

GROUP CONFIG MODEL MACH NO PO PSIA TO DEG R ALPHA-WONDEL ALPHA-SECTOR ALPHA-PREBEND ROLL-MODEL YAW
276 4153 GDC-R+DWD R+00 565.6 1302 -4.97 -4.97 0 0 0
T-1NF P-1NF Q-1NF V-1NF RMO-1NF MU-1NF RE-FT HREF STREF
(DEG R) (PSIA) (PSIA) (FT/SEC) (SLUGS/FT³) (LB-SEC/FT²) (FT-1) (R= .013FT) (R= .013FT)
94.3 .058 2.595 3807 5.152E-05 7.595E-08 2.58E 06 4.641E-02 2.947E-02

CAMERA PAINT FMP (DEG F) INITIAL TEMP (DEG F) SQUARE ROOT (RHODACKI)
TOP(TT) 275
SIDE(LS) 275 AVERAGE TM = 73 (R) --.0081(SQUARE ROOT DEL TIME) * 0.11
SIDE(LS) 275 AVERAGE TM = 90 (C)

PIC NC	TIME DELTIME	H(TO)	H(TO)/HREF	H(.910)	H(.910)/HREF	H(.8510)	H(.8510)/HREF	H(.8510)	H(.8510)/HREF	ST(TO)	MODEL TEMP F
LS 3601 (275)	4.10	3.03	0 1.51E-02	.3246	1.928E-02	.4153	2.242E-02	.4830	9.507E-03	0	73 92 92
LS 3601 (275)	4.10	3.03	R 1.64E-02	.3523	2.090E-02	.4502	2.429E-02	.5233	1.032E-02	0	73 92 92
LS 3601 (275)	4.10	3.03	R 1.64E-02	.3523	2.090E-02	.4502	2.429E-02	.5233	1.032E-02	0	73 92 92
LS 3601 (275)	4.10	3.03	0 1.51E-02	.3246	1.928E-02	.4153	2.242E-02	.4830	9.507E-03	0	73 92 92
LS 3613 (275)	10.25	9.18	0 7.73E-03	.1666	9.891E-03	.2132	1.150E-02	.2479	4.881E-03	0	74 97 110
LS 3613 (275)	10.25	9.18	R R.39E-03	.1808	1.072E-02	.2311	1.246E-02	.2686	5.297E-03	0	74 97 110
LS 3613 (275)	10.25	9.18	R R.39E-03	.1808	1.072E-02	.2311	1.246E-02	.2686	5.297E-03	0	74 97 110
LS 3613 (275)	10.25	9.18	0 7.73E-03	.1666	9.891E-03	.2132	1.150E-02	.2479	4.881E-03	0	74 97 110
LS 3625 (275)	16.35	15.28	0 5.50E-03	.1186	7.403E-03	.1517	8.186E-03	.1764	3.474E-03	0	76 101 126
LS 3625 (275)	16.35	15.28	H 5.97E-03	.1287	7.631E-03	.1645	R.870E-03	.1912	3.770E-03	0	76 101 126
LS 3625 (275)	16.35	15.28	H 5.97E-03	.1287	7.631E-03	.1645	R.870E-03	.1912	3.770E-03	0	76 101 126
LS 3625 (275)	16.35	15.28	R 5.97E-03	.1287	7.631E-03	.1645	8.870E-03	.1912	3.770E-03	0	76 101 126
LS 3625 (275)	16.35	15.28	0 5.50E-03	.1186	7.403E-03	.1517	8.186E-03	.1764	3.474E-03	0	76 101 126
LS 3637 (275)	22.50	21.43	0 4.31E-03	.0928	5.509E-03	.1188	6.407E-03	.1381	2.120E-03	0	79 106 139
LS 3637 (275)	22.50	21.43	H 4.67E-03	.1007	5.972E-03	.1288	6.942E-03	.1497	2.952E-03	0	79 106 139
LS 3637 (275)	22.50	21.43	R 4.67E-03	.1007	5.972E-03	.1288	6.942E-03	.1497	2.952E-03	0	79 106 139
LS 3637 (275)	22.50	21.43	0 4.31E-03	.0928	5.509E-03	.1188	6.407E-03	.1381	2.120E-03	0	79 106 139

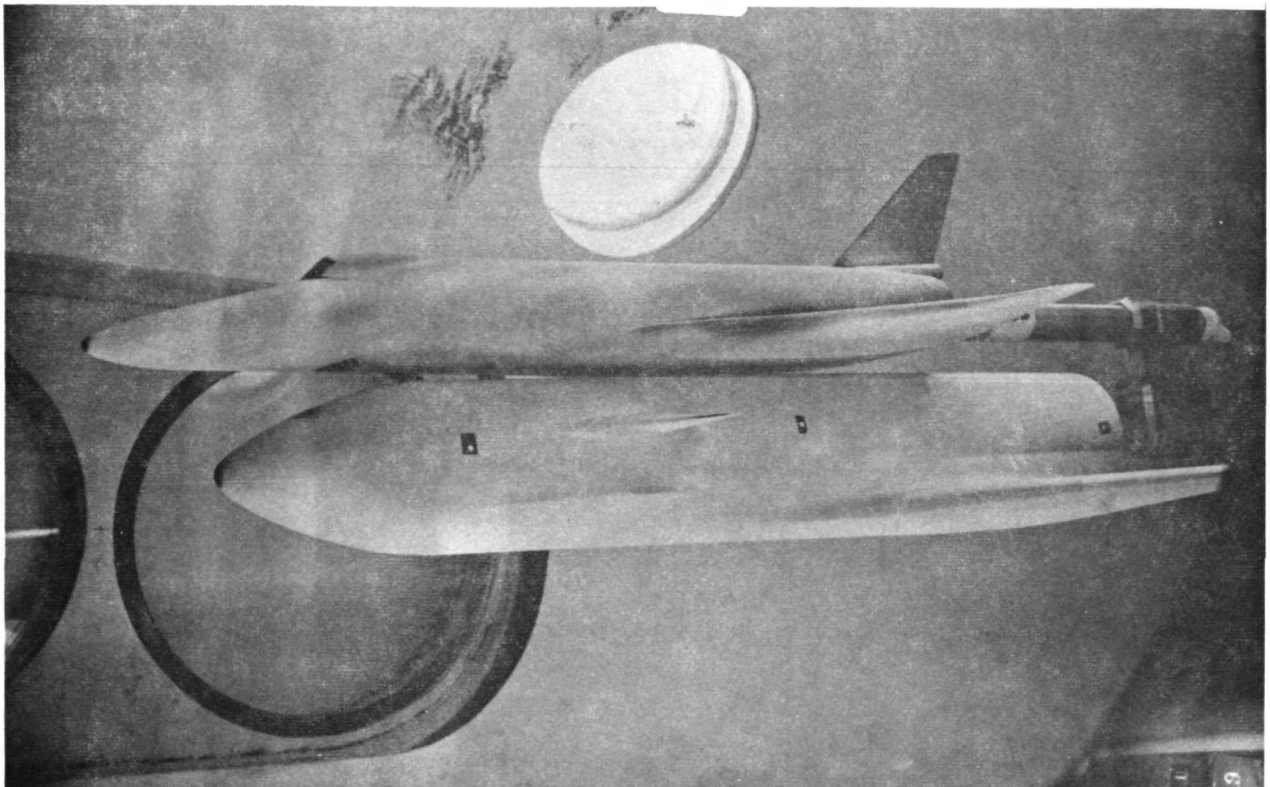

Pic. No. 3601 H/HREF = .3523 BOOSTER
.3246 ORBITER

3601
6719

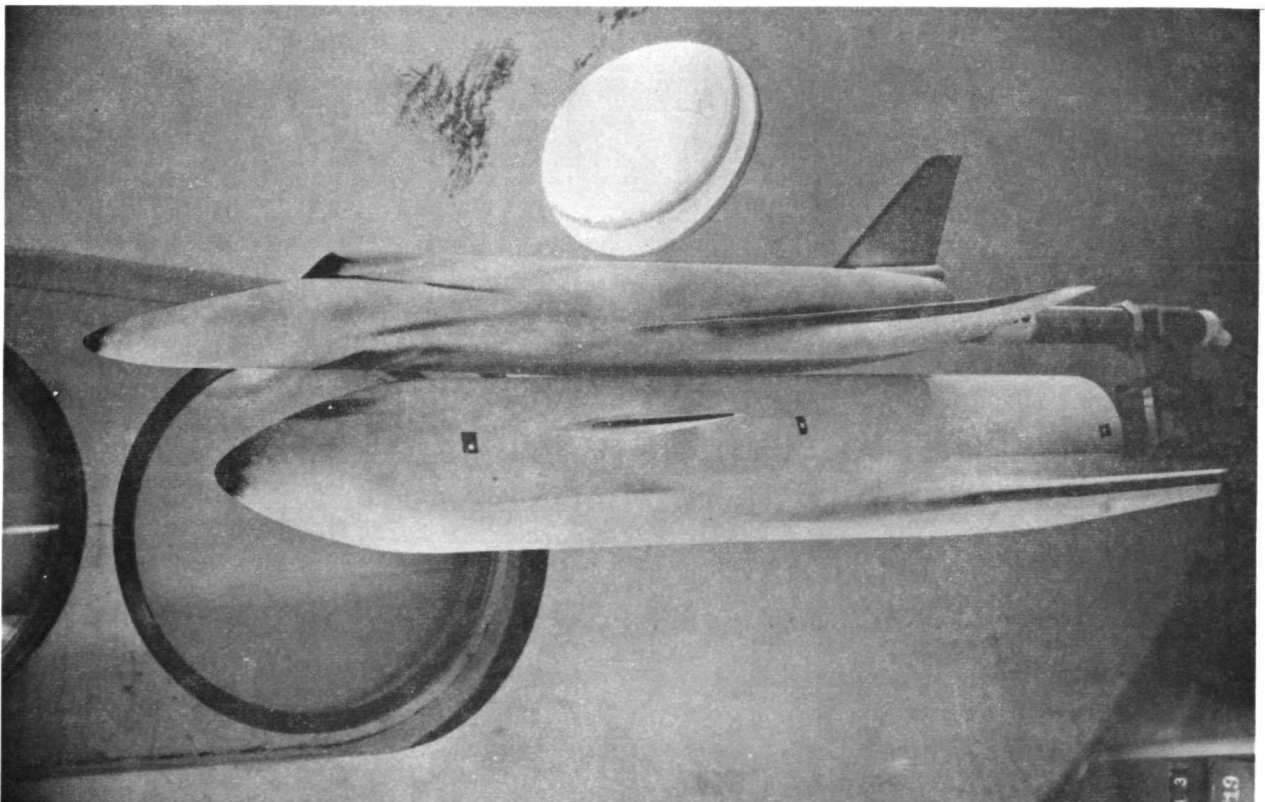

Pic. No. 3613 H/HREF = .1808 BOOSTER
.1666 ORBITER

3613
6719

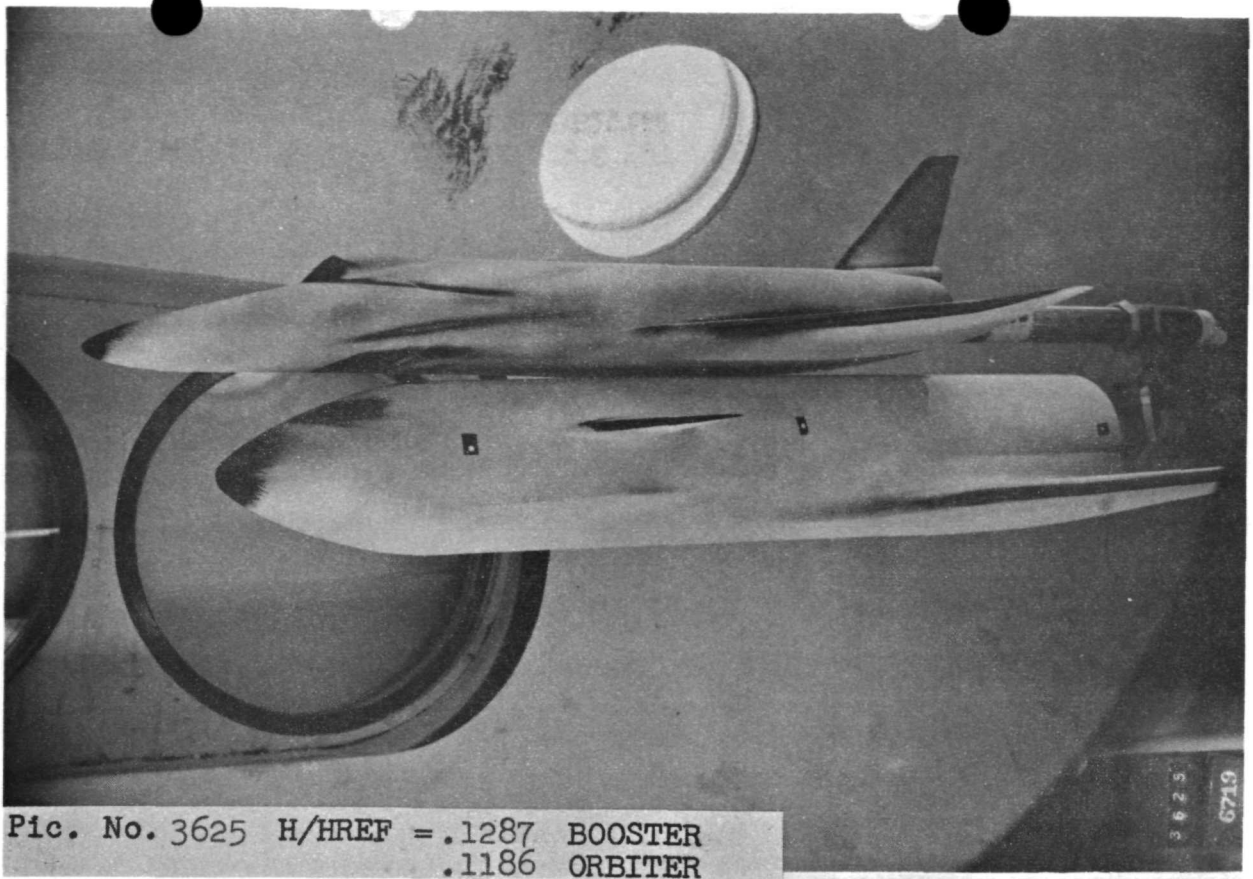

Pic. No. 3625 H/HREF = .1287 BOOSTER
.1186 ORBITER

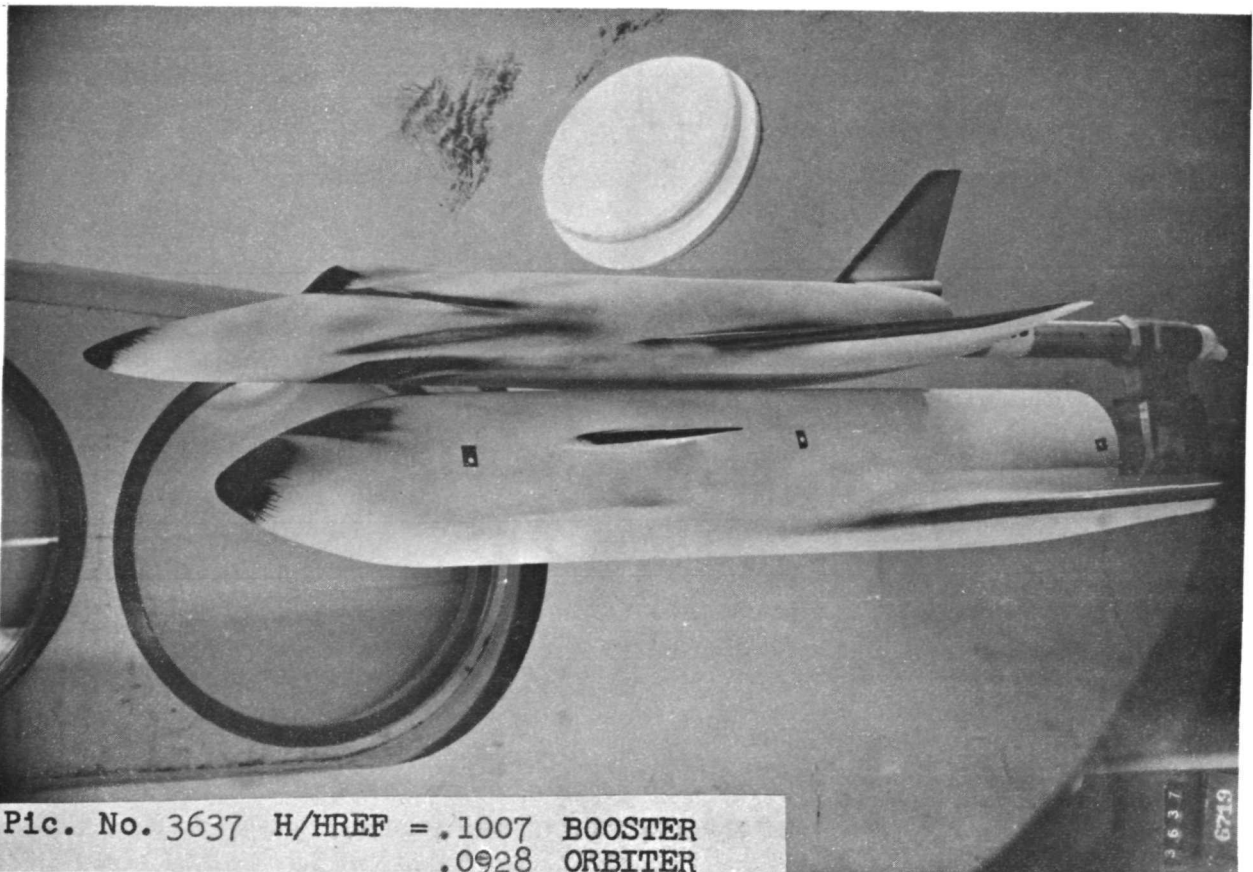

Pic. No. 3637 H/HREF = .1007 BOOSTER
.0928 ORBITER

6/ 4/71

AEDC(ARO,INC.) ARNOLD AFS, TENNESSEE
VON KARMAN GAS DYNAMICS FACILITY
50 INCH HYPERSONIC TUNNEL B
V11162

GROUP 237 CONFIG 6253 MODEL EDC-B+DWO MACH NO R.00 PO PSIA 565.7 TO DEG R 1299 ALPHA-MODEL ALPHA-SECTOR ALPHA-PREBEND ROLL-MODEL VAR

T-INF P-INF Q-INF V-INF RHO-INF MU-INF REF/T HREF STNEF
(DEG R) (PSIA) (PSIA) (FT/SEC) (SLUGS/FT3) (LB-SEC/FT2) (FT-1) (R=.013FT) (R=.013FT)
94.2 .058 7.596 3A04 5.163E-05 7.580E-08 2.59E 06 4.640E-02 2.943E-02

CAMERA PAINT TEMP (DEG F) INITIAL TEMP (DEG F) SQUARE ROOT (RHOXCXK)
TOP(T) 150
SIDE(US) 150 AVERAGE TM = 72 (R)
SIDE(LS) 150 AVERAGE TM = 94 (O) - .0081(SQUARE ROOT DEL TIME) + 0.11

PIC NO	TIME	DELTIME	H(TO)	H(TO)/HREF	H(.910)	H(.910)/HREF	H(.8510)	H(.8510)/HREF	ST(TO)	MODEL	TEMP F
LS 3655	(150)	3.55	2.48	0 4.35E-03	.0937	5.338E-03	.1150	6.024E-03	.1298	2.761E-03	0 72 95 97
LS 3655	(150)	3.55	2.48	R 6.03E-03	.1300	7.393E-03	.1593	8.337E-03	.1797	3.830E-03	0 72 95 97
LS 3655	(150)	3.55	2.48	R 6.03E-03	.1300	7.393E-03	.1593	8.337E-03	.1797	3.830E-03	0 72 95 97
LS 3655	(150)	3.55	2.48	0 4.35E-03	.0937	5.338E-03	.1150	6.024E-03	.1298	2.761E-03	0 72 95 97
LS 3668	(150)	10.20	9.13	R 2.77E-03	.0597	3.397E-03	.0732	3.831E-03	.0826	1.760E-03	0 74 100 115
LS 3668	(150)	10.20	9.13	R 2.77E-03	.0597	3.397E-03	.0732	3.831E-03	.0826	1.760E-03	0 74 100 115
LS 3668	(150)	10.20	9.13	R 2.77E-03	.0597	3.397E-03	.0732	3.831E-03	.0826	1.760E-03	0 74 100 115
LS 3668	(150)	10.20	9.13	0 1.39E-03	.0299	1.704E-03	.0367	1.923E-03	.0415	8.820E-04	0 77 106 131
LS 3681	(150)	16.80	15.73	R 1.93E-03	.0415	2.360E-03	.0509	2.662E-03	.0574	1.224E-03	0 77 106 131
LS 3681	(150)	16.80	15.73	R 1.93E-03	.0415	2.360E-03	.0509	2.662E-03	.0574	1.224E-03	0 77 106 131
LS 3681	(150)	16.80	15.73	R 1.93E-03	.0415	2.360E-03	.0509	2.662E-03	.0574	1.224E-03	0 77 106 131
LS 3681	(150)	16.80	15.73	0 1.39E-03	.0299	1.704E-03	.0367	1.923E-03	.0415	8.820E-04	0 77 106 131
LS 3693	(150)	25.40	24.37	R 1.01E-03	.0217	1.235E-03	.0266	1.394E-03	.0301	6.395E-04	0 81 113 148
LS 3693	(150)	25.40	24.37	R 1.40E-03	.0301	1.710E-03	.0369	1.929E-03	.0416	8.871E-04	0 81 113 148
LS 3693	(150)	25.40	24.37	R 1.40E-03	.0301	1.710E-03	.0369	1.929E-03	.0416	8.871E-04	0 81 113 148
LS 3693	(150)	25.40	24.37	0 1.01E-03	.0217	1.235E-03	.0266	1.394E-03	.0301	6.395E-04	0 81 113 148

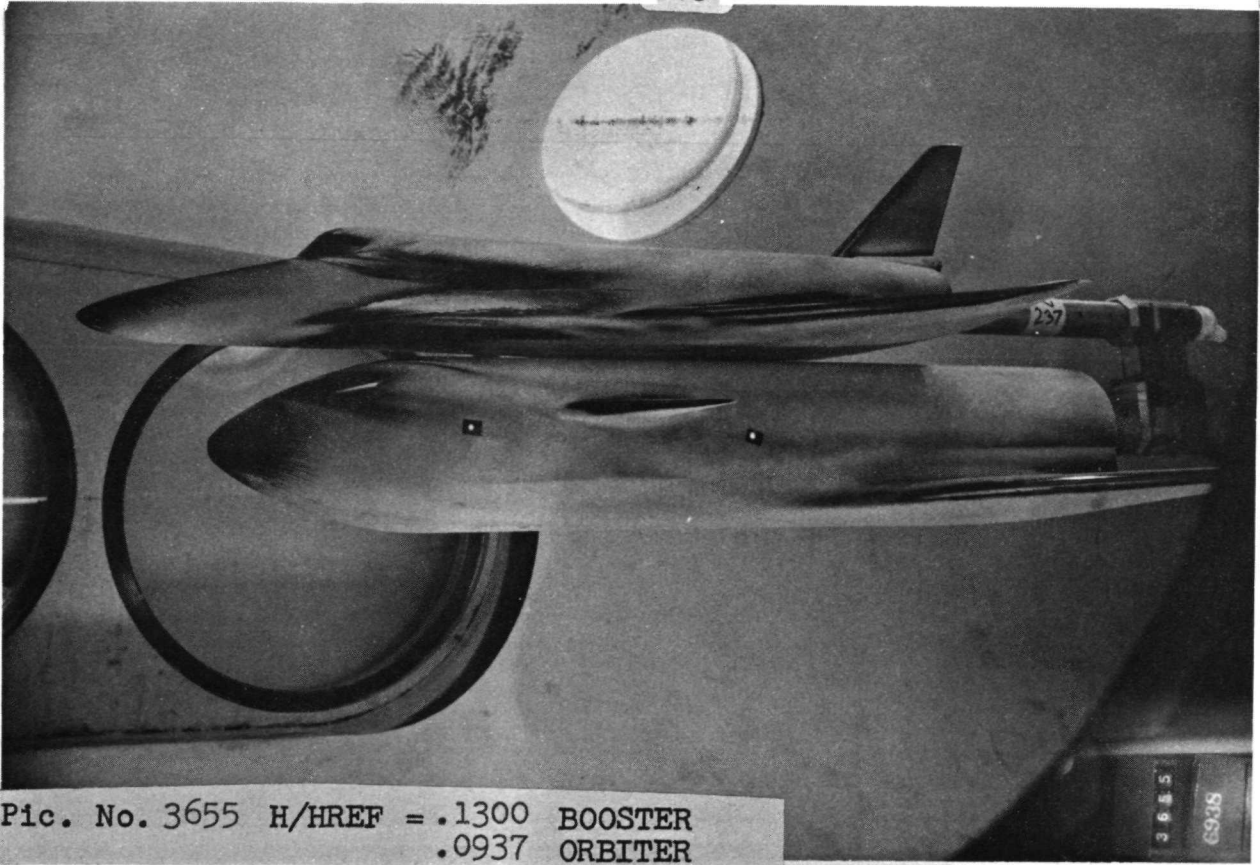

Pic. No. 3655 H/HREF = .1300 BOOSTER
.0937 ORBITER

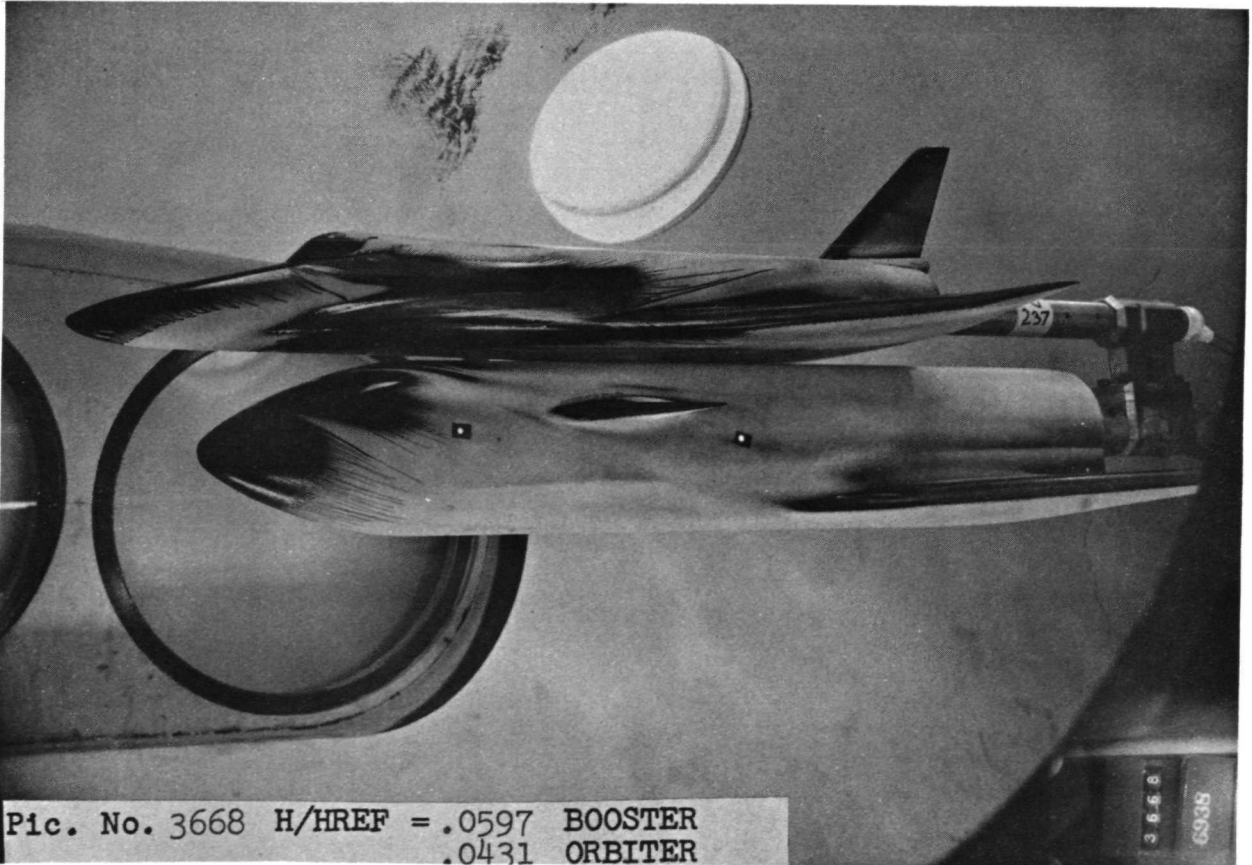

Pic. No. 3668 H/HREF = .0597 BOOSTER
.0431 ORBITER

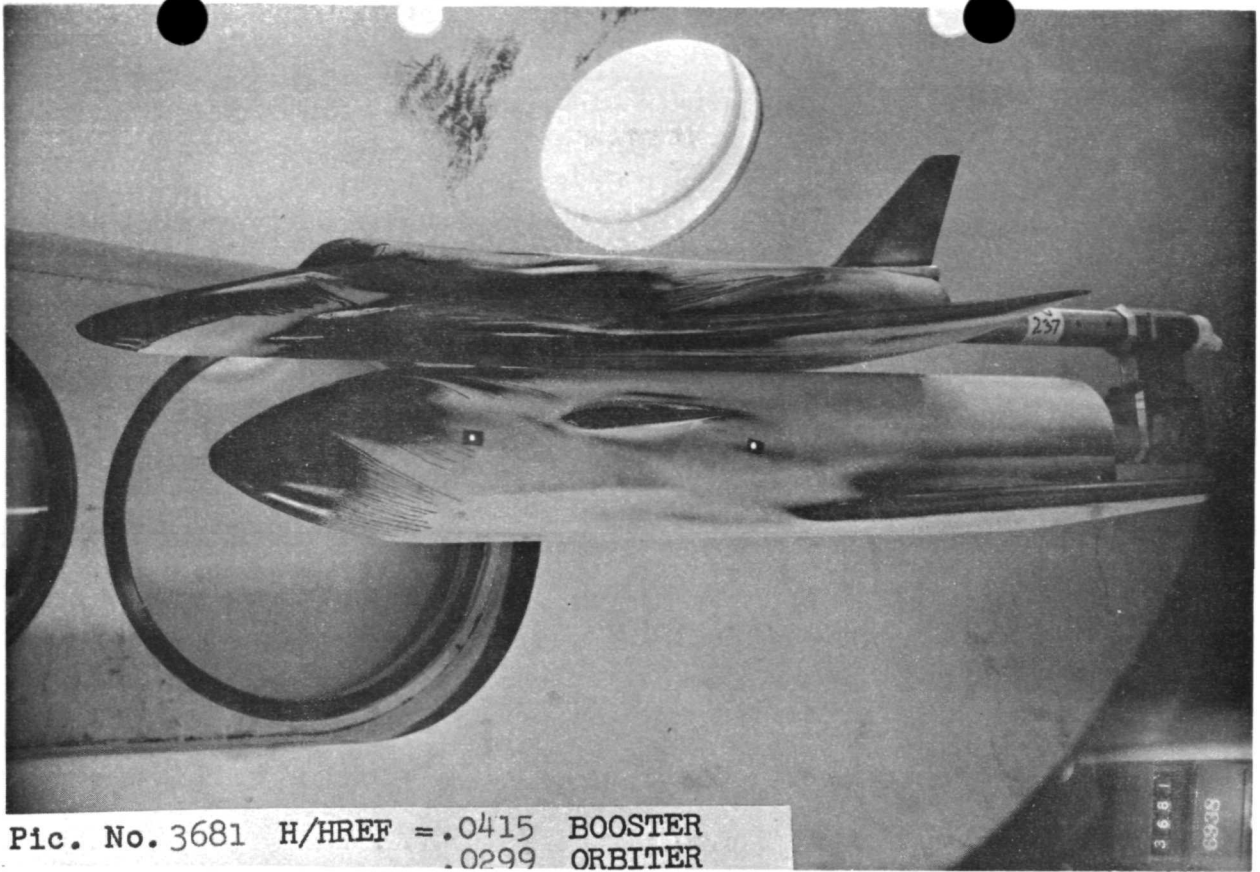

Pic. No. 3681 H/HREF = .0415 BOOSTER
.0299 ORBITER

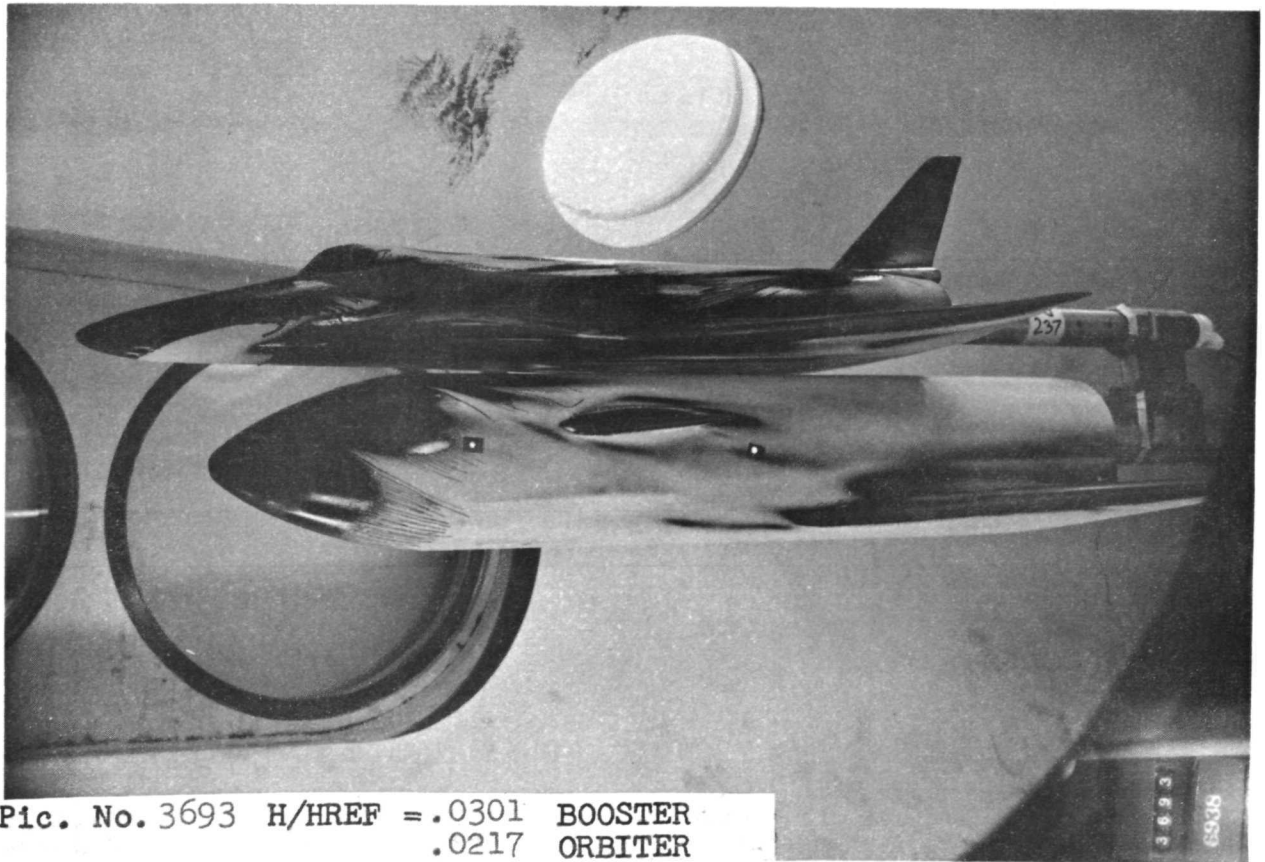

Pic. No. 3693 H/HREF = .0301 BOOSTER
.0217 ORBITER

6/4/71

AEDC(ARO, INC.) ARNOLD AFS, TENNESSEE
VON KARMAN GAS DYNAMICS FACILITY
50 INCH HYPERSONIC TUNNEL R
V11162

GROUP 234 CONFIG 6153 MODEL GDC-R+DWO MACH NO R.00 PO PSIA 585.3 TO DEG R 1286 ALPHA-MODEL 5.02 ALPHA-SECTOR 5.02 ALPHA-PREBEND 0 ROLL-MODEL 0 YAW 0

T-INF P-INF O-INF V-INF RHO-INF MU-INF RE/FT H-REF STINEF
(DEG R) (PSIA) (PSIA) (FT/SEC) (SLUGS/FT3) (LB-SEC/FT2) (FT-1) (R= .013FT) (R= .013FT)
93.2 .058 2.594 3784 5.213E-05 7.503E-08 2.63E 06 4.628E-02 2.926E-02

CAVEFA PAINT TEMP (DEG F) INITIAL TEMP (DEG F) SQUARE ROOT (RHOCXK)

TOP(T) 300 AVERAGE TM = 75 (R)
SIDE(US) 300 AVERAGE TW = 90 (O)
SIDE(LS) 300 -0.008(SQUARE ROOT DEL TIME) + 0.11

PIC NC	TIME DELTIME	H(TO)	H(TO)/HREF	H(.9TO)	H(.9TO)/HREF	H(.85TO)	H(.85TO)/HREF	ST(TO)	MODEL TEMP F	
LS 3511 (300)	3.70	2.63	0 1.98E-02	.4267	2.568E-02	.5547	3.024E-02	.6533	1.240E-02	0 74 91 90
LS 3511 (300)	3.70	2.63	8 2.10E-02	.4546	2.734E-02	.5905	3.218E-02	.6950	1.321E-02	0 74 91 90
LS 3511 (300)	3.70	2.63	8 2.10E-02	.4546	2.734E-02	.5905	3.218E-02	.6950	1.321E-02	0 74 91 90
LS 3511 (300)	3.70	2.63	0 1.98E-02	.4267	2.568E-02	.5547	3.024E-02	.6533	1.240E-02	0 74 91 90
LS 3522 (300)	9.90	8.83	0 9.59E-03	.2071	1.246E-02	.2692	1.468E-02	.3171	6.021E-03	0 76 95 98
LS 3522 (300)	9.90	8.83	8 1.02E-02	.2206	1.326E-02	.2866	1.561E-02	.3373	6.414E-03	0 76 95 98
LS 3523 (300)	9.90	8.83	8 1.02E-02	.2206	1.326E-02	.2866	1.561E-02	.3373	6.414E-03	0 76 95 98
LS 3523 (300)	9.90	8.83	0 9.59E-03	.2071	1.246E-02	.2692	1.468E-02	.3171	6.021E-03	0 76 95 98
LS 3535 (300)	16.05	14.98	0 6.75E-03	.1457	8.770E-03	.1894	1.033E-02	.2231	4.236E-03	0 79 99 106
LS 3535 (300)	16.05	14.98	8 7.19E-03	.1552	9.335E-03	.2016	1.099E-02	.2374	4.513E-03	0 79 99 106
LS 3535 (300)	16.05	14.98	8 7.19E-03	.1552	9.335E-03	.2016	1.099E-02	.2374	4.513E-03	0 79 99 106
LS 3535 (300)	16.05	14.98	0 6.75E-03	.1457	8.770E-03	.1894	1.033E-02	.2231	4.236E-03	0 79 99 106
LS 3546 (300)	26.60	25.53	0 4.55E-03	.0982	5.914E-03	.1277	6.965E-03	.1504	2.855E-03	0 84 105 117
LS 3546 (300)	26.60	25.53	8 4.85E-03	.1046	6.295E-03	.1359	7.410E-03	.1600	3.042E-03	0 84 105 117
LS 3546 (300)	26.60	25.53	8 4.85E-03	.1046	6.295E-03	.1359	7.410E-03	.1600	3.042E-03	0 84 105 117
LS 3546 (300)	26.60	25.53	0 4.55E-03	.0982	5.914E-03	.1277	6.965E-03	.1504	2.855E-03	0 84 105 117

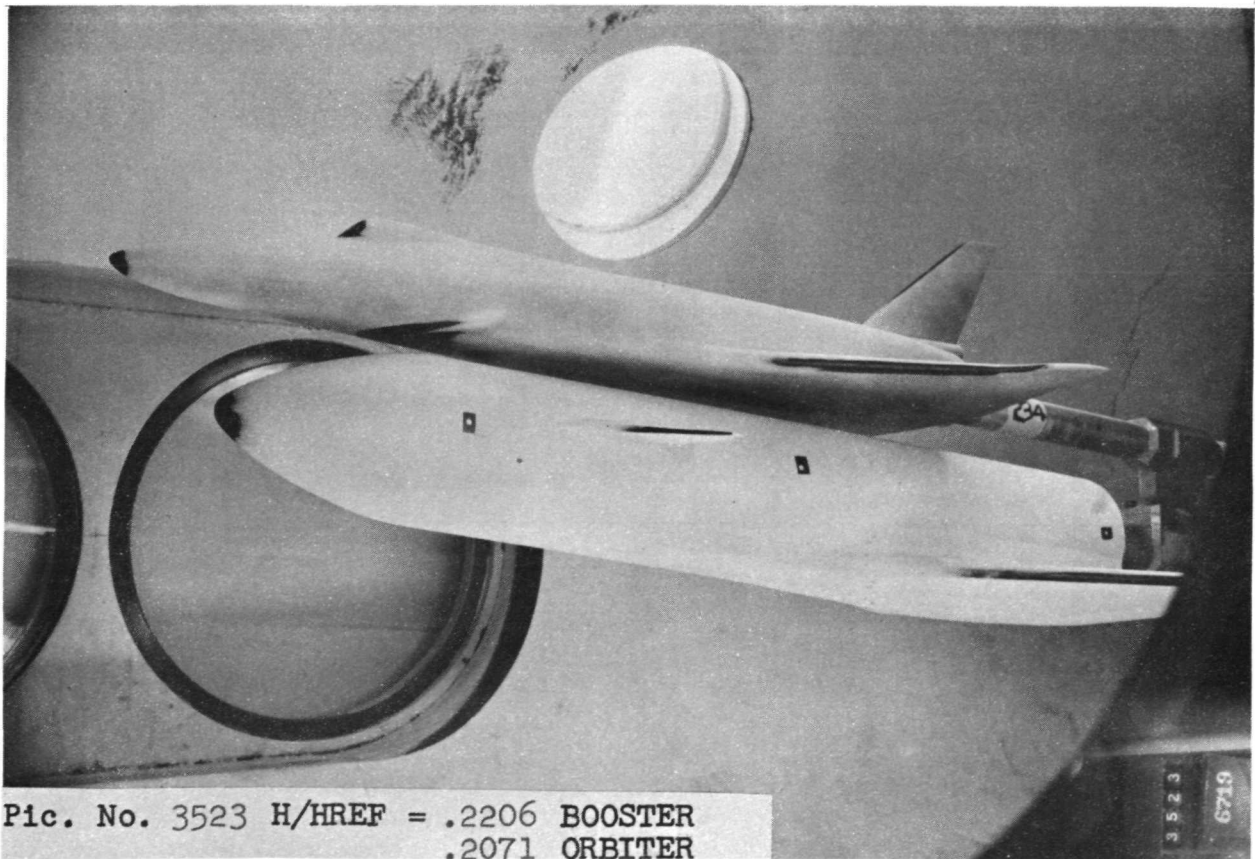
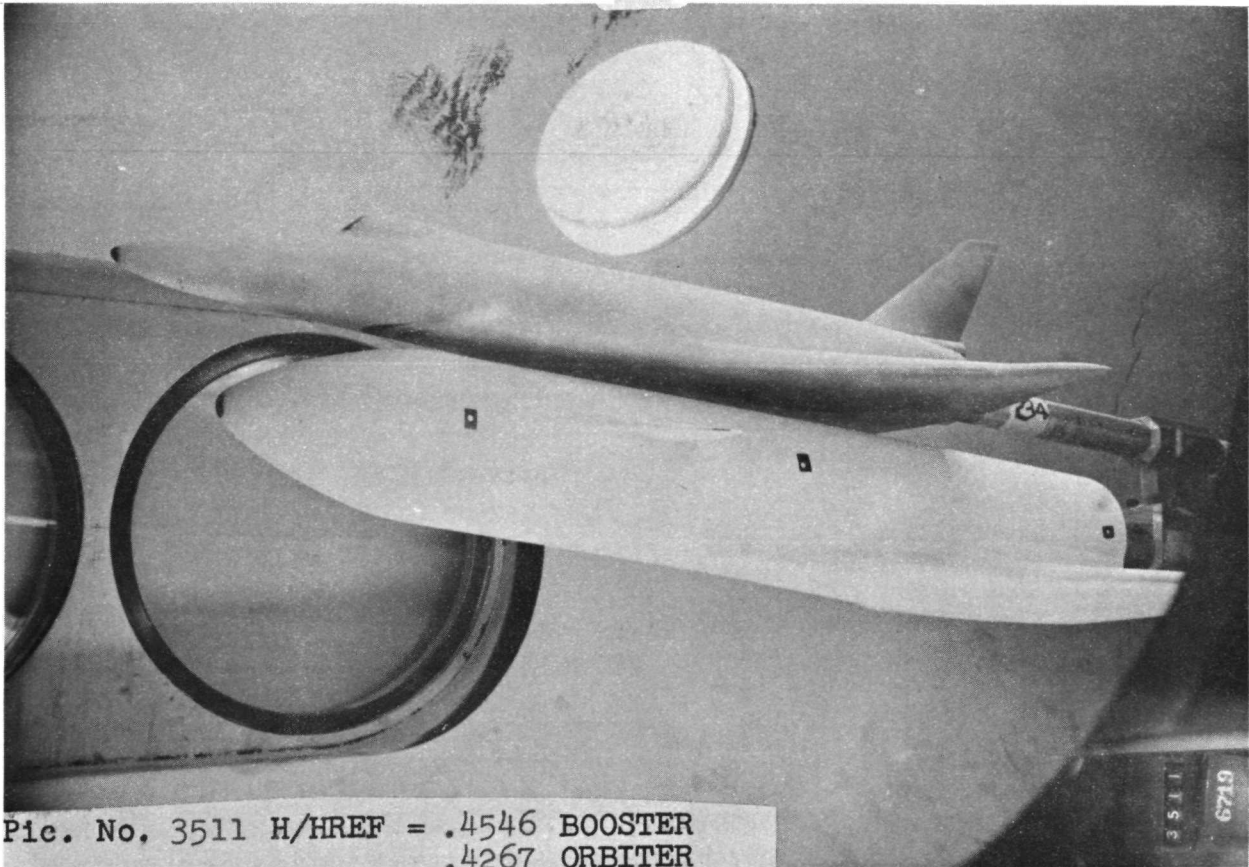

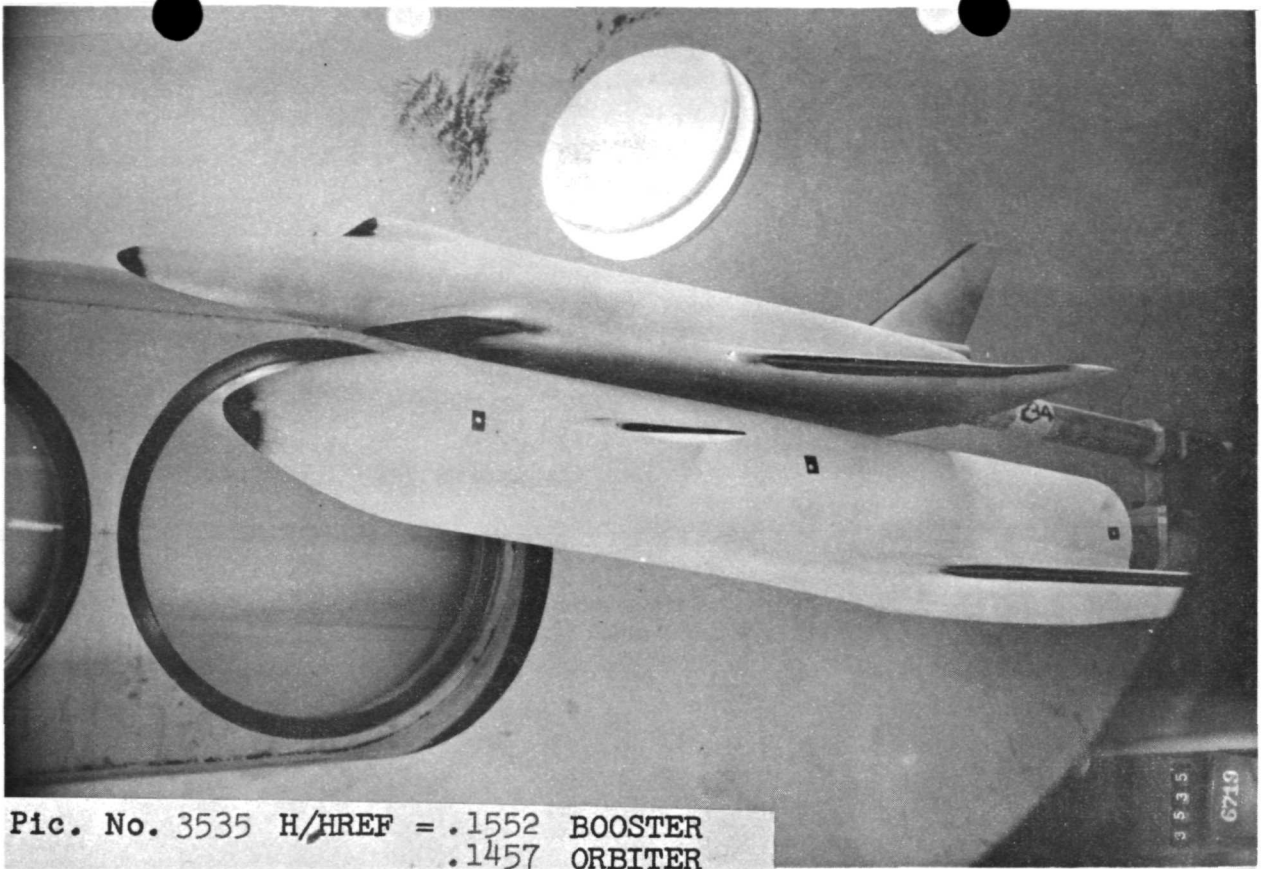

Pic. No. 3535 H/HREF = .1552 BOOSTER
.1457 ORBITER

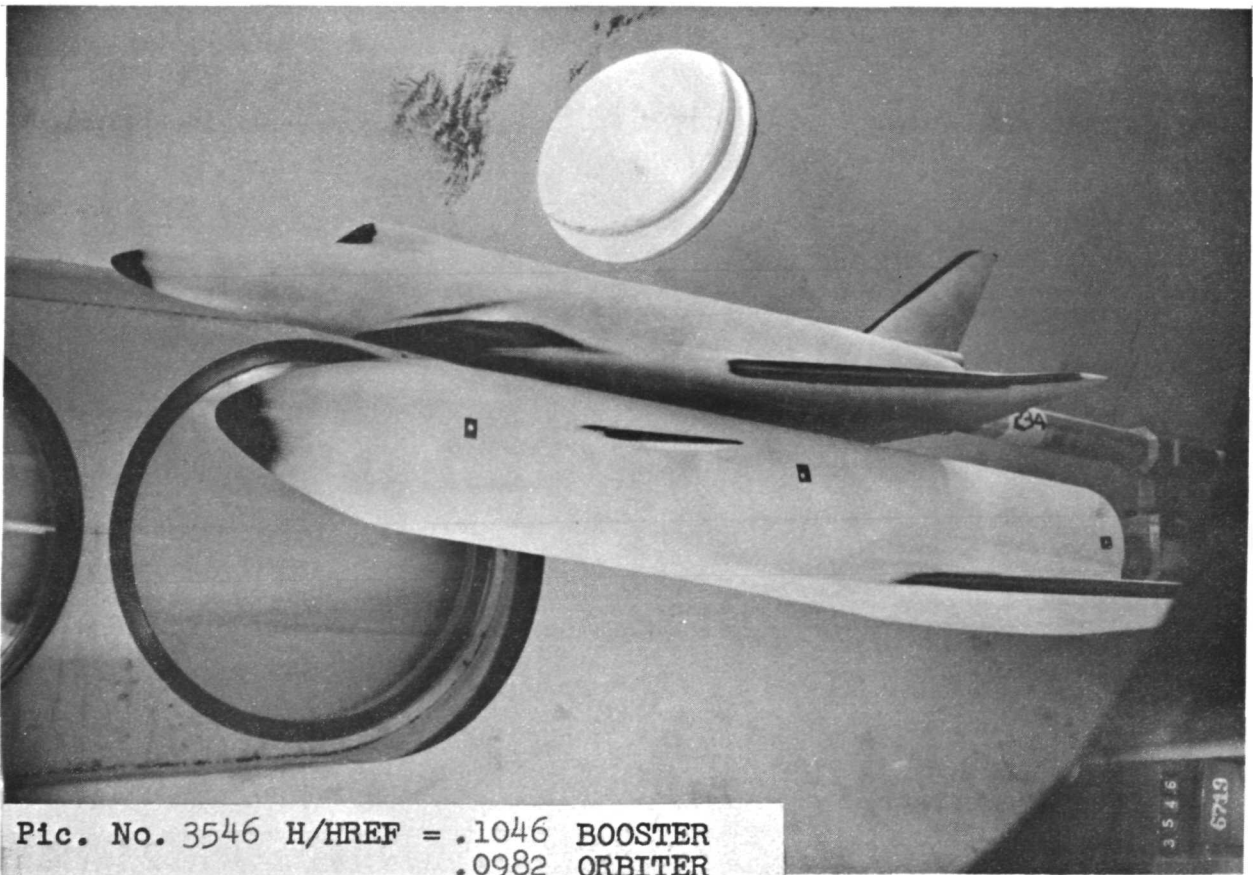

Pic. No. 3546 H/HREF = .1046 BOOSTER
.0982 ORBITER

6/ 4/71

AEDICARO, INC.) ARNOLD AFS, TENNESSEE
VON KARMAN GAS DYNAMICS FACILITY
50 INCH HYPERSONIC TUNNEL B
VII1162

GROUP 236 CONFIG 6253 MODEL EDC-B-DWO MACH NO 9.00 P0 PSIA 564.2 10 DEG R 1319 ALPHA-PODEL 5.03 ALPHA-SECTOR 5.03 ALPHA-PREBEND 0 ROLL-MODEL 0 YAW 0

T-INF P-INF O-INF V-INF RHO-INF MU-INF RE/FT HREF STREF
(DEG R) (PSIA) (PSIA) (F/SEC) (SLUGS/FT3) (LB-SEC/FT2) (FT-1) (R=.013FT) (R=.013FT)
95.6 .058 2.589 3033 5.072E-05 7.697E-08 2.53E 06 4.646E-02 2.974E-02

PAINT TEMP (DEG F) INITIAL TEMP (DEG F) SQUARE ROOT (RHOCXK)
TOP(T) 150 AVERAGE TW = 75 (R)
SIDE(S) 150 AVERAGE TW = 93 (C) --.008(SQUARE ROOT DEL TIME) + 0.11

PIC NO	TIME DELTIME	H(TO)	H(TO)/HREF	H(.910)	H(.910)/HREF	H(.8510)	H(.8510)/HREF	ST(TO)	MODEL	TEMP F
LS 3551 (150)	4.25	3.1P	0 3.77E-03	.0813	4.619E-03	.0994	5.202E-03	.1120	2.420E-03	75 95 94
LS 3551 (150)	4.25	3.1A	8 4.89E-03	.1053	5.982E-03	.1288	6.731E-03	.1449	3.137E-03	75 95 94
LS 3551 (150)	4.25	3.1B	8 4.89E-03	.1053	5.982E-03	.1288	6.731E-03	.1449	3.137E-03	75 95 94
LS 3551 (150)	4.25	3.1C	0 3.77E-03	.0813	4.619E-03	.0994	5.202E-03	.1120	2.420E-03	75 95 94
LS 3563 (150)	13.35	12.2A	0 1.65E-03	.0354	2.013E-03	.0433	2.267E-03	.0488	1.055E-03	80 101 107
LS 3563 (150)	13.35	12.2B	8 2.13E-03	.0459	2.607E-03	.0561	2.934E-03	.0632	1.367E-03	80 101 107
LS 3563 (150)	13.35	12.2C	8 2.13E-03	.0459	2.607E-03	.0561	2.934E-03	.0632	1.367E-03	80 101 107
LS 3563 (150)	13.35	12.2D	0 1.65E-03	.0354	2.013E-03	.0433	2.267E-03	.0488	1.055E-03	80 101 107
LS 3575 (150)	19.50	18.43	0 1.24E-03	.0267	1.517E-03	.0327	1.709E-03	.0368	7.949E-04	83 105 115
LS 3575 (150)	19.50	18.44	8 1.61E-03	.0346	1.965E-03	.0423	2.211E-03	.0476	1.030E-03	83 105 115
LS 3575 (150)	19.50	18.45	8 1.61E-03	.0346	1.965E-03	.0423	2.211E-03	.0476	1.030E-03	83 105 115
LS 3575 (150)	19.50	18.46	0 1.24E-03	.0267	1.517E-03	.0327	1.709E-03	.0368	7.949E-04	83 105 115
LS 3586 (150)	25.15	24.0A	0 1.01E-03	.0218	1.241E-03	.0267	1.398E-03	.0301	6.505E-04	86 108 122
LS 3586 (150)	25.15	24.0B	8 1.31E-03	.0283	1.607E-03	.0346	1.808E-03	.0389	8.431E-04	86 108 122
LS 3586 (150)	25.15	24.0C	8 1.31E-03	.0283	1.607E-03	.0346	1.808E-03	.0389	8.431E-04	86 108 122
LS 3586 (150)	25.15	24.0D	0 1.01E-03	.0218	1.241E-03	.0267	1.398E-03	.0301	6.505E-04	86 108 122

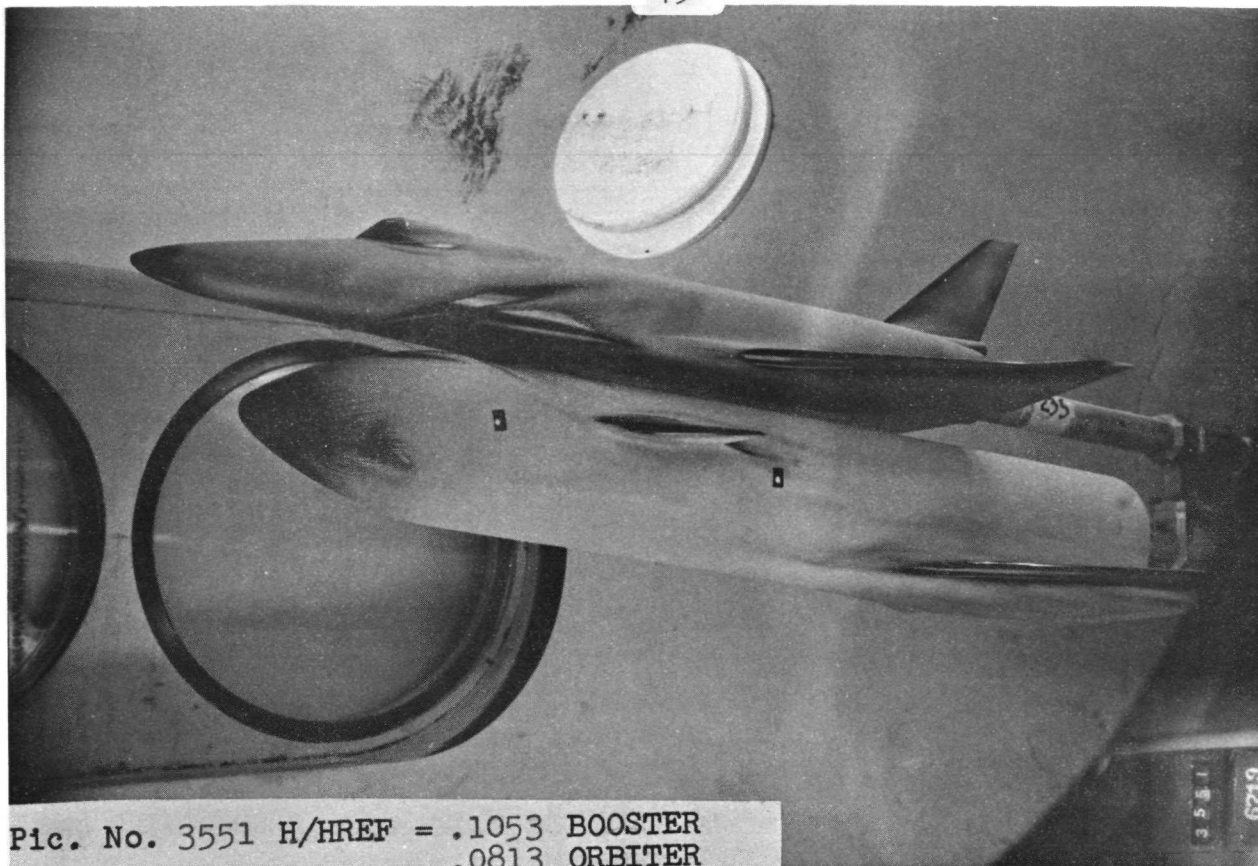

Pic. No. 3551 H/HREF = .1053 BOOSTER
.0813 ORBITER

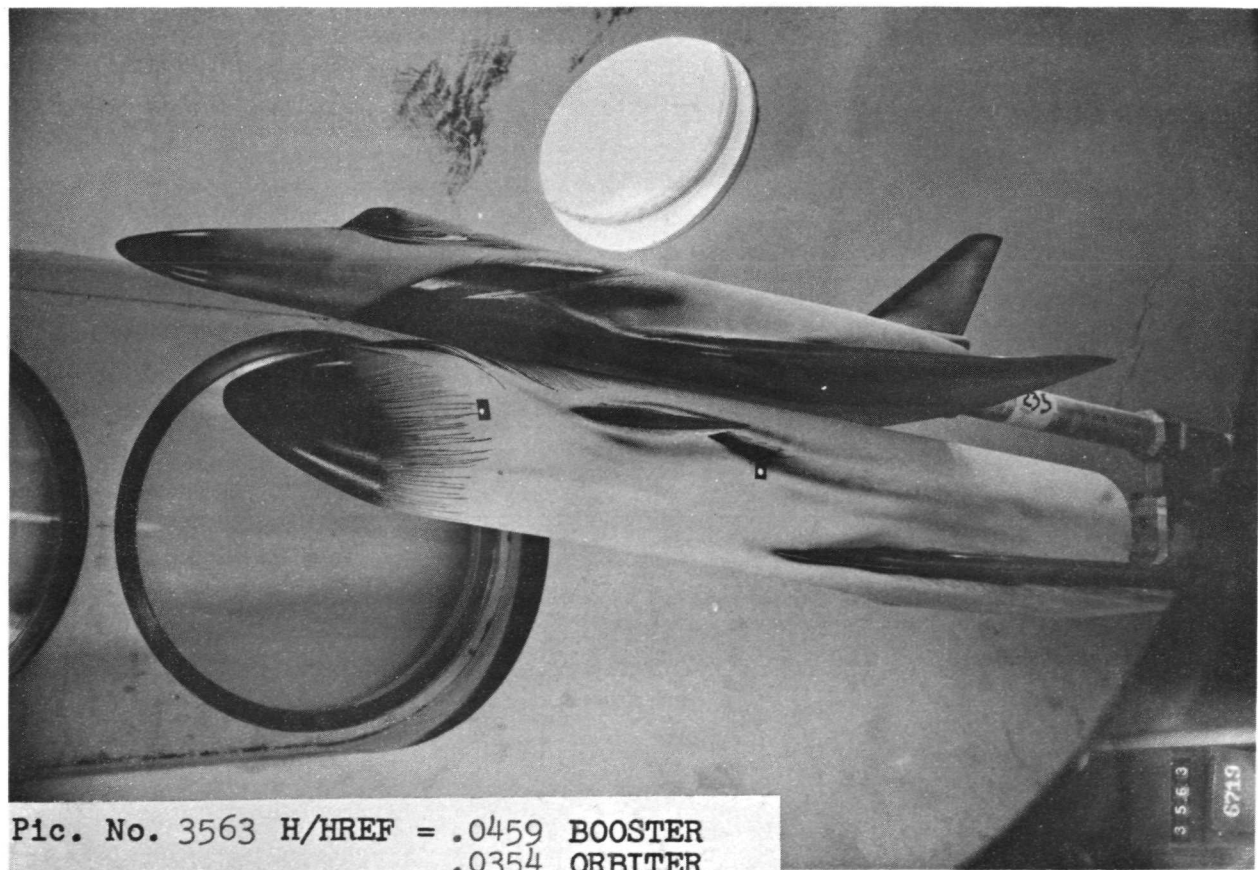

Pic. No. 3563 H/HREF = .0459 BOOSTER
.0354 ORBITER



Pic. No. 3575 H/HREF = .0346 BOOSTER
 .0267 ORBITER

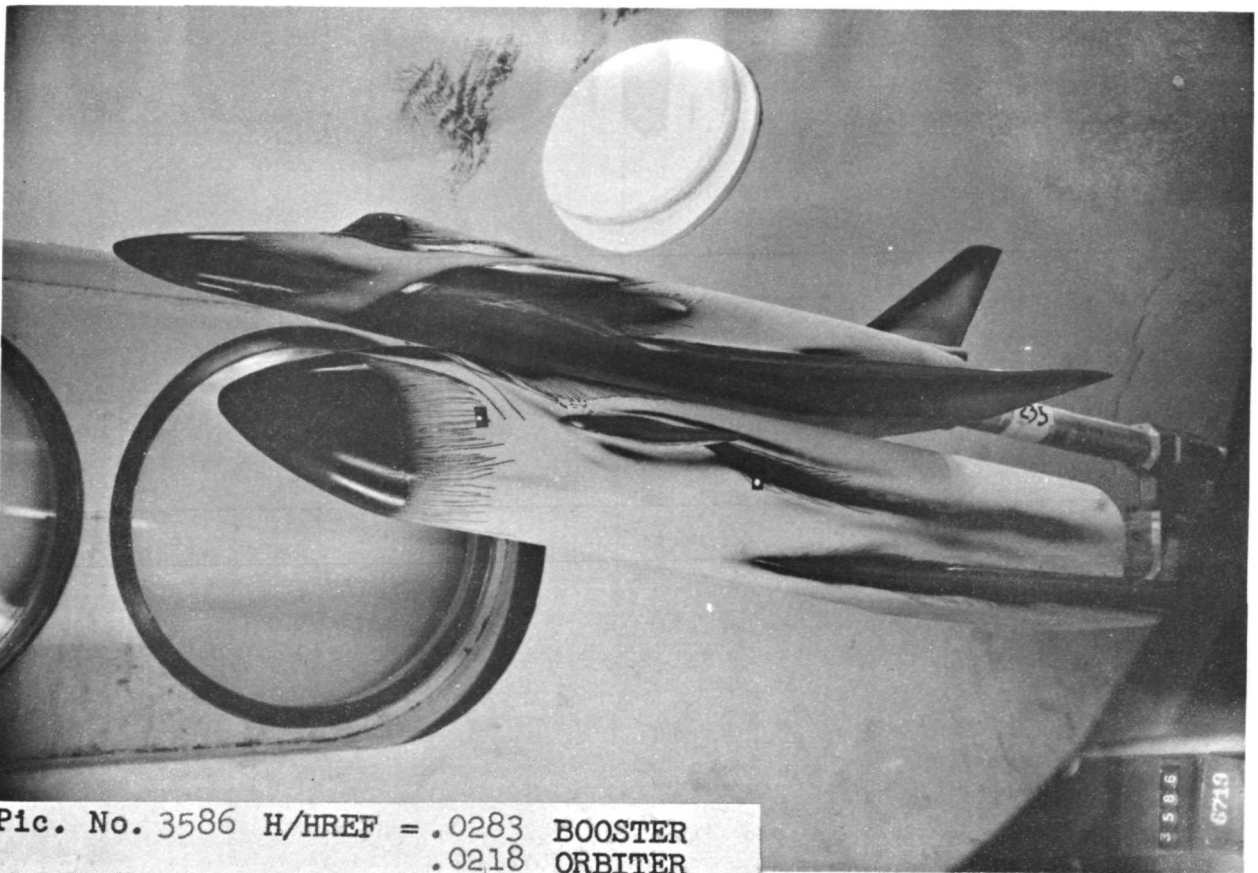

Pic. No. 3586 H/HREF = .0283 BOOSTER
 .0218 ORBITER

6/ 4/71

AEDC(ARO,INC.) ARNOLD AFS, TENNESSEE
VON KARMAN GAS DYNAMICS FACILITY
50 INCH HYPERSONIC TUNNEL B
VT1162

GROUP	CONFIG	MODEL	MACH NO	PO PSIA	TO DEG R	ALPHA-MODEL	ALPHA-SECTOR	ALPHA-PREBEND	ROLL-MODEL	YAW
242	A153	EDC-8*0W0	8.00	565.5	1332	.01	.01	0	0	0
	T-INF	P-INF	O-INF	V-INF	RHO-INF	MU-INF	RE/FT	HREF	STREF	
	(OEG R)	(PSIA)	(PSIA)	(FT/SEC)	(SLUGS/FT3)	(LB-SEC/FT2)	(FT-1)	(R= .013FT)	(R= .013FT)	
	96.5	.058	2.595	3852	5.034E-05	7.773E-08	2.49E-06	4.668E-02	2.988E-02	

OIL FLOW

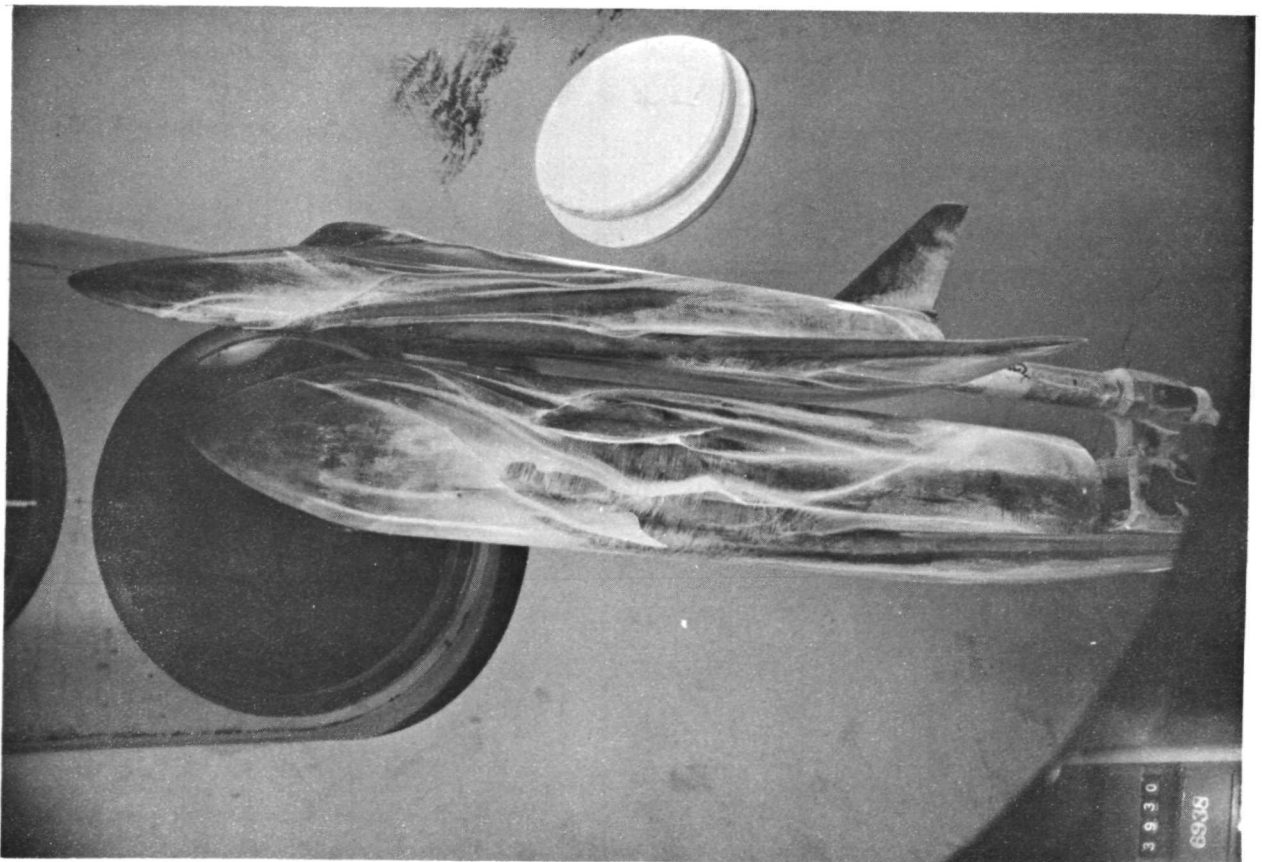
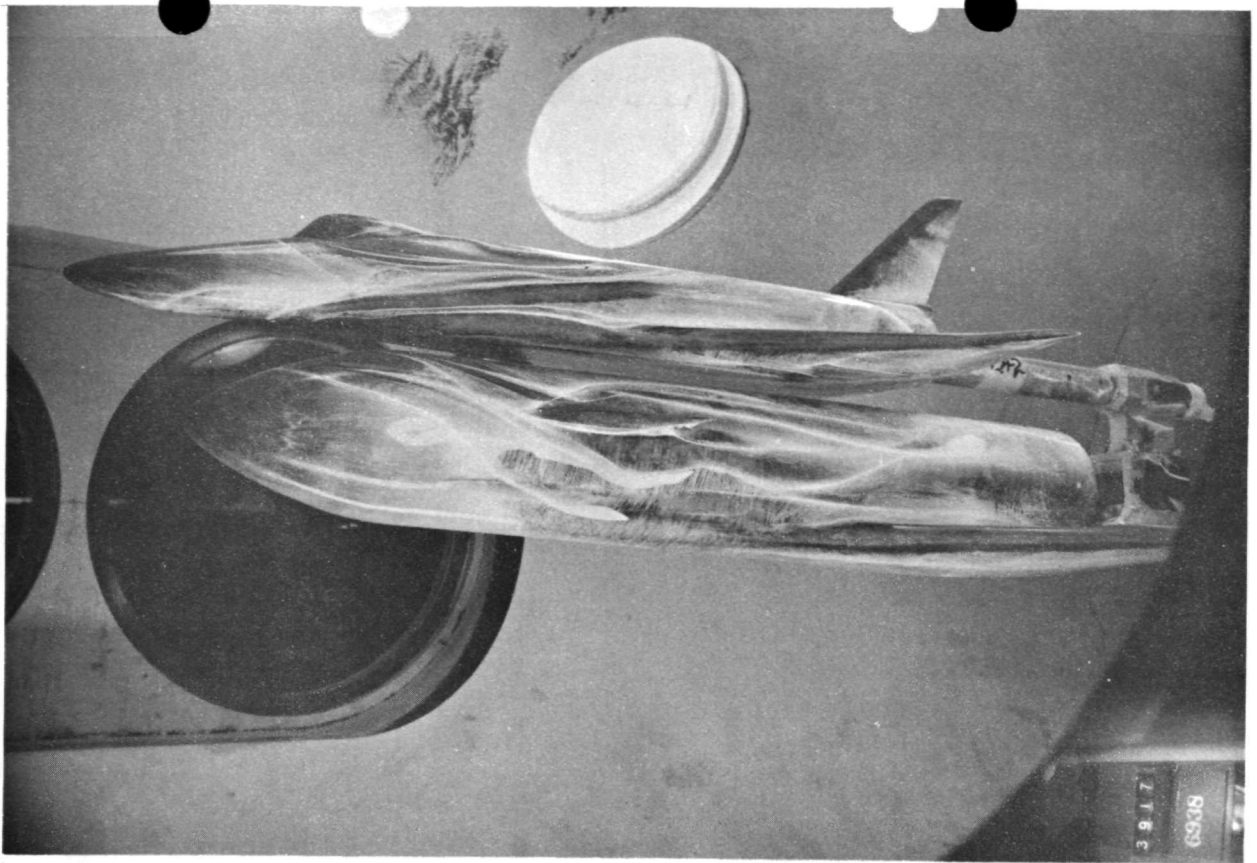

Group 242 Re/ft 2.49E 06 ALPHA 0

6/ 4/71

AEDC(ARO,INC.) ARNOLD AFS, TENNESSEE
VON KARMAN GAS DYNAMICS FACILITY
50 INCH HYPERSONIC TUNNEL B
V11162

GROUP	CONFIG	MODEL	MACH NO	PO PSIA	TO DEG R	ALPHA-MODEL	ALPHA-SECTOR	ALPHA-REBEND	ROLL-MODEL	YAW
241	6153	EDC-R-CMO	R.00	566.2	1326	-4.99	-4.99	0	0	0
	T-INF	P-INF	Q-INF	V-INF	RHO-INF	MU-INF	RE/FT	HREF	STREF	
	(DEG R)	(PSIA)	(PSIA)	(FT/SEC)	(SLUGS/FT ³)	(LB-SEC/FT ²)	(FT-1)	(R= .013FT)	(R= .013FT)	
	96.1	.058	2.598	3842	5.065E-05	7.735E-08	2.52E 06	4.659E-02	2.978E-02	

OIL FLOW

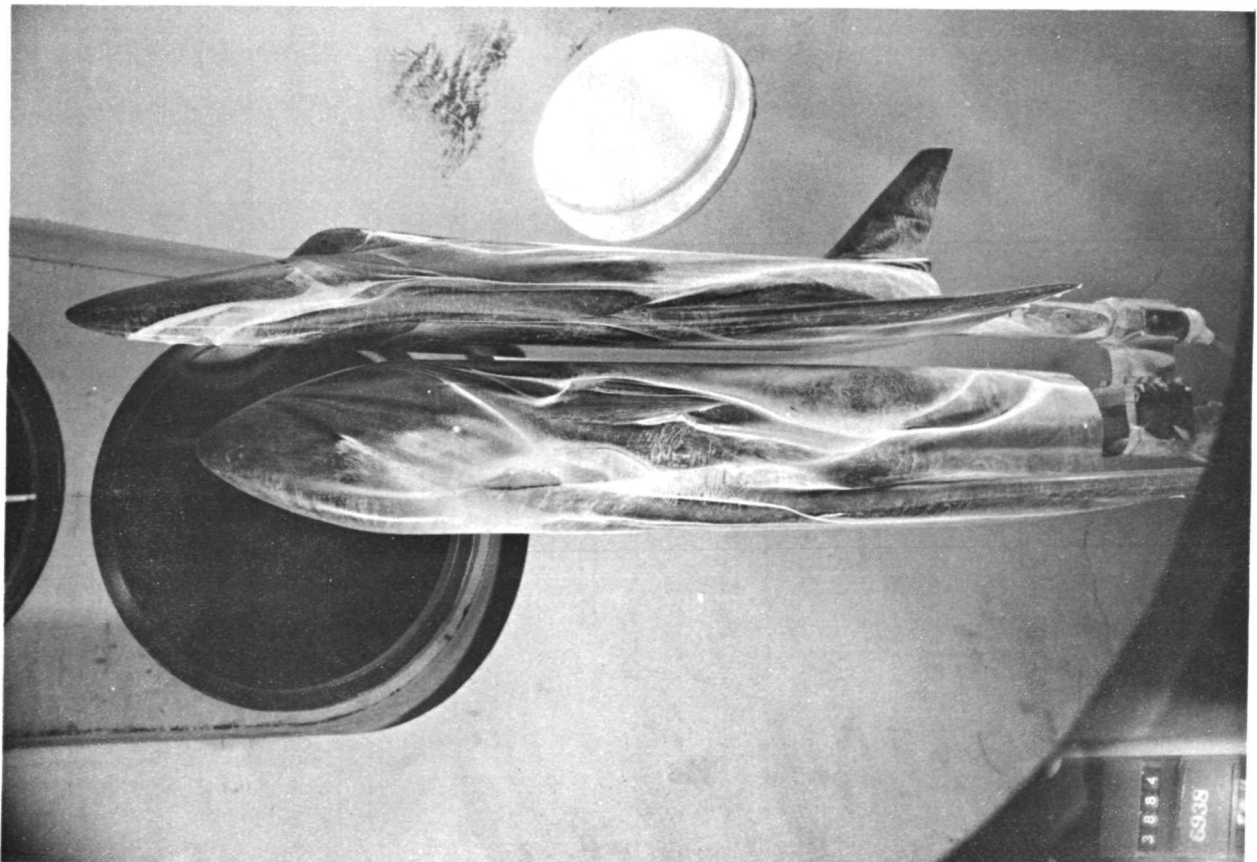
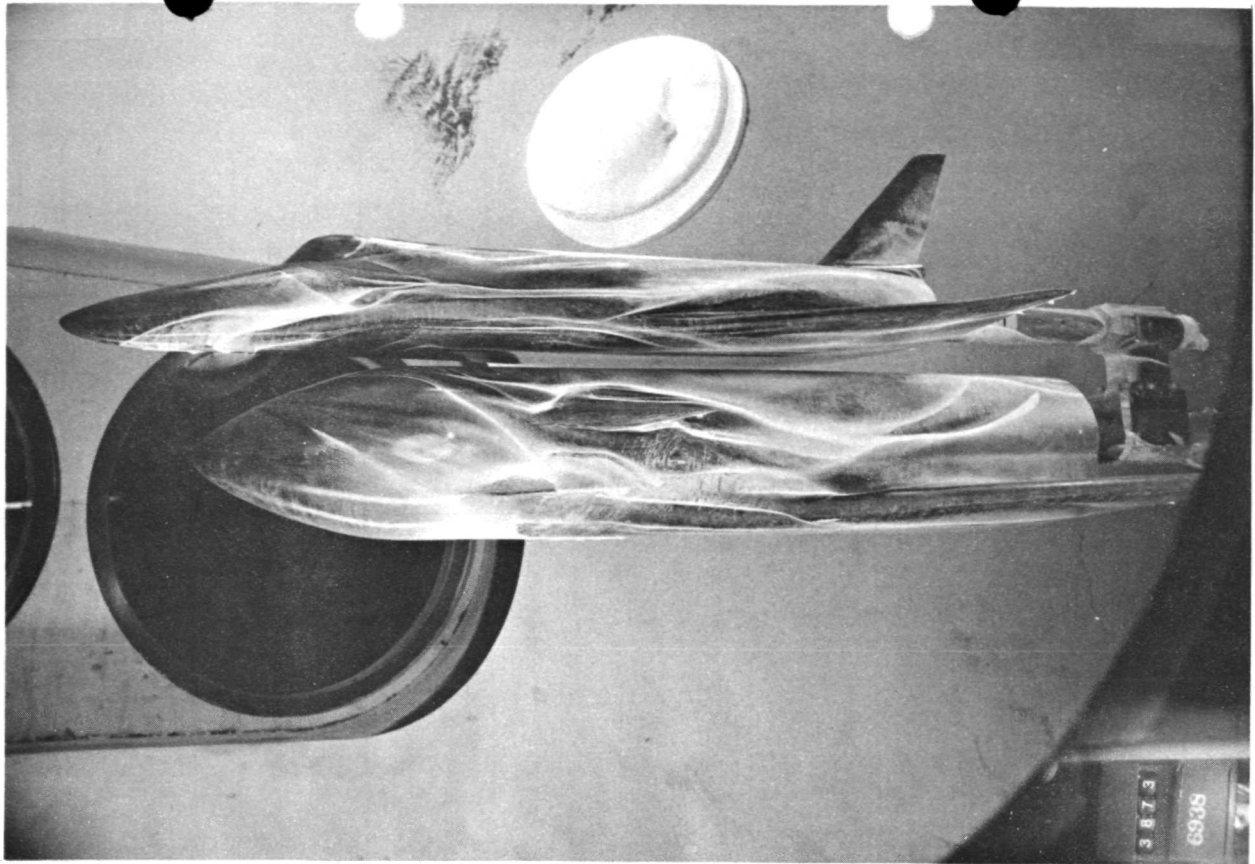

Group 241 Re/ft 2.52E 06 ALPHA -5

6/ 4/71

AEDCIARD, INC.) ARNOLD AFS, TENNESSEE
VON KARMAN GAS DYNAMICS FACILITY
50 INCH HYPERSONIC TUNNEL R
V71162

GROUP	CONF IG	MODEL	MACH NO	PO PSIA	TD DEG R	ALPHA-MODEL	ALPHA-SECTOR	ALPHA-PREBEND	ROLL-MODEL	YAW
240	4153	GDC-8+CMR	8.00	565.5	1317	5.01	5.01	0	0	0
T-INF	P-INF	0-INF	V-INF	RHO-INF	PU-INF	RE/FT	HREF	STREF		
(DEG R)	(PSIA)	(PSIA)	(FT/SEC)	(SLUGS/FT ³)	(LB-SEC/FT ²)	(FT-1)	(R= .013FT)	(R= .013FT)		
95.5	.058	2.595	3830	5.090E-05	7.086E-08	2.94E 06	4.451E-02	2.968E-02		

OIL FLOW

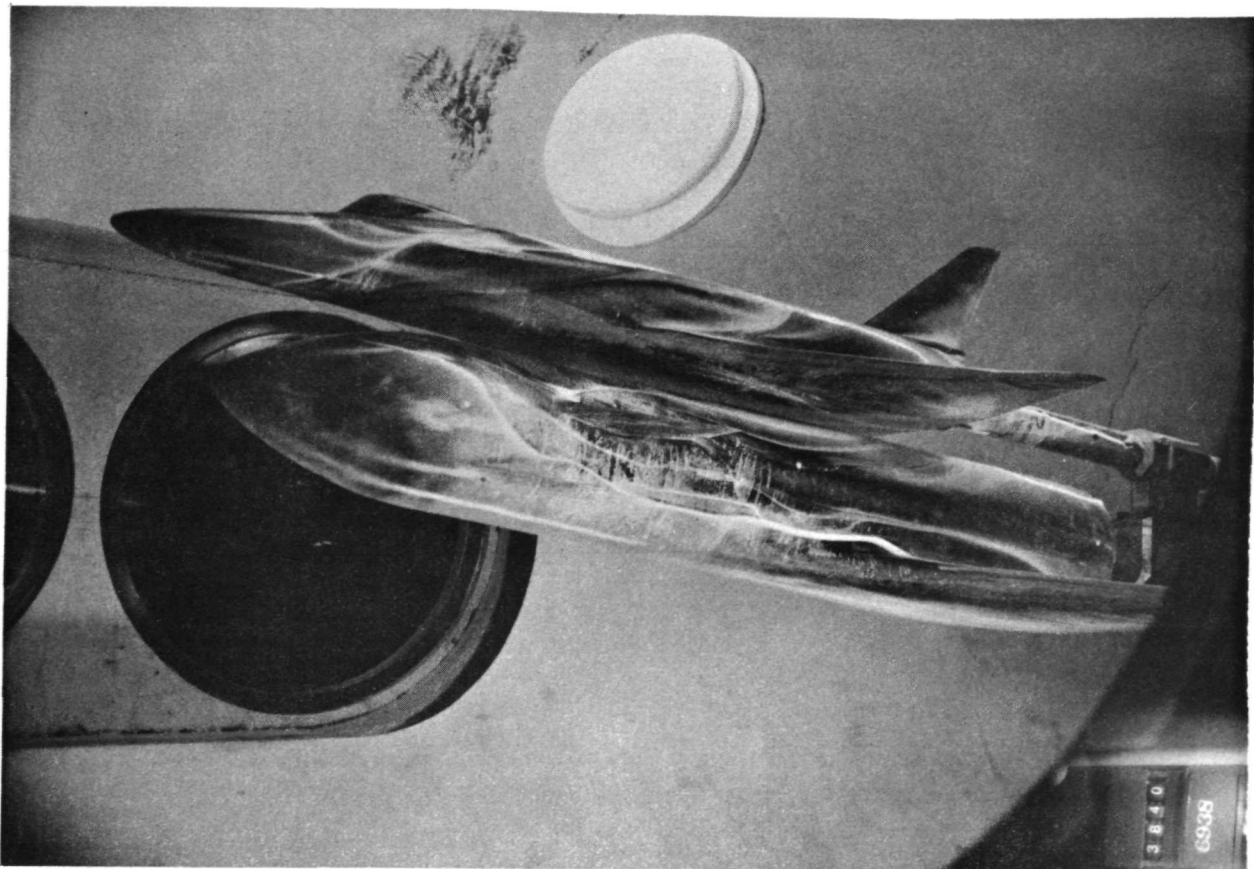
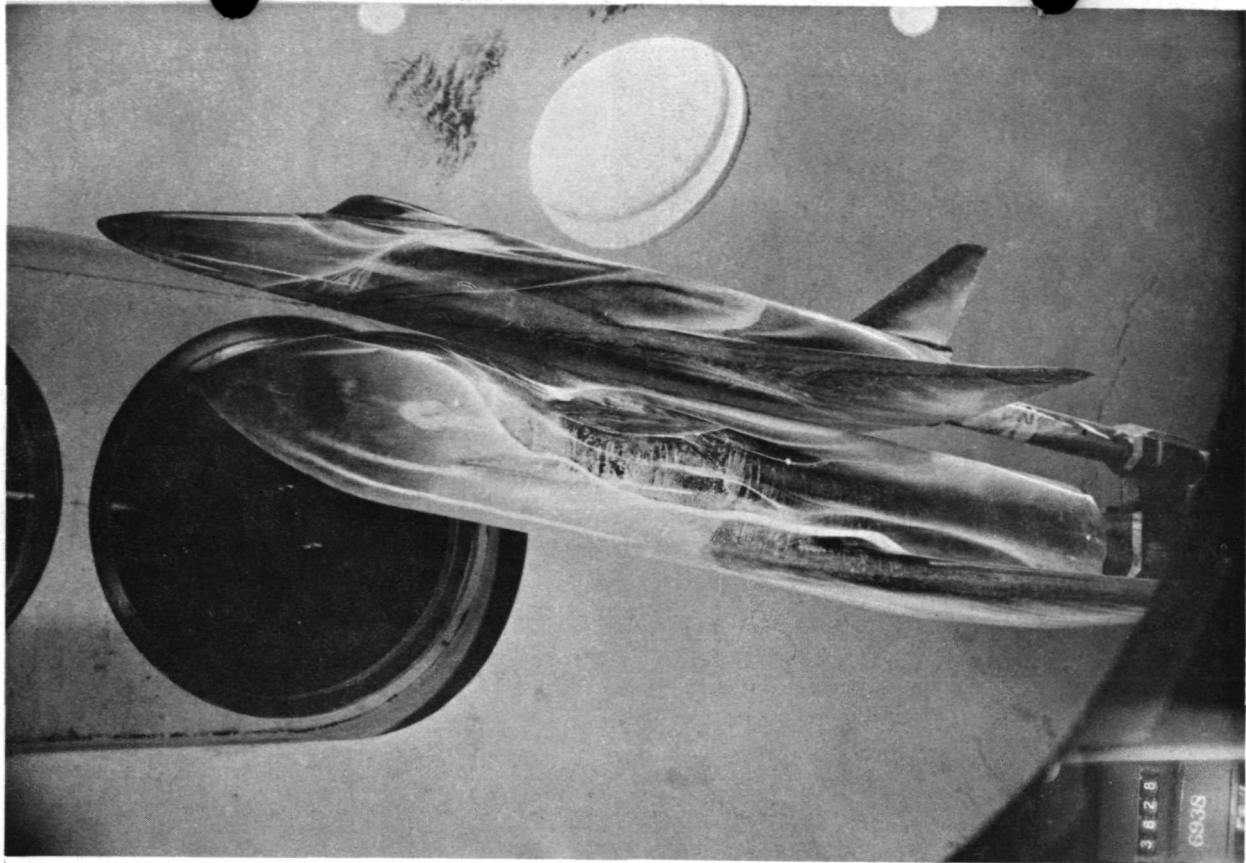

Group 240 Re/ft 2.54E 06 ALPHA 5

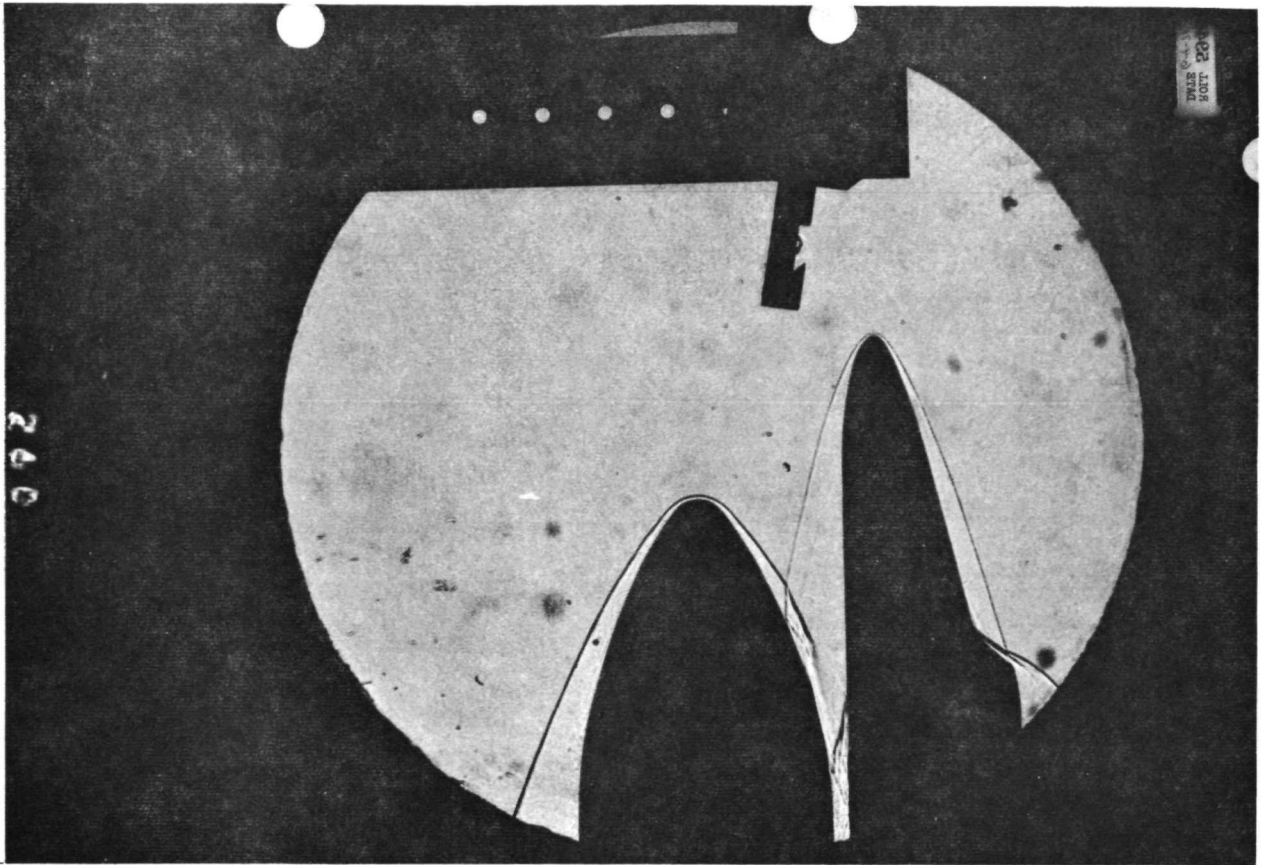

260
1-3-57

260

Group 260 Re/ft 2.54 06 ALPHA 0

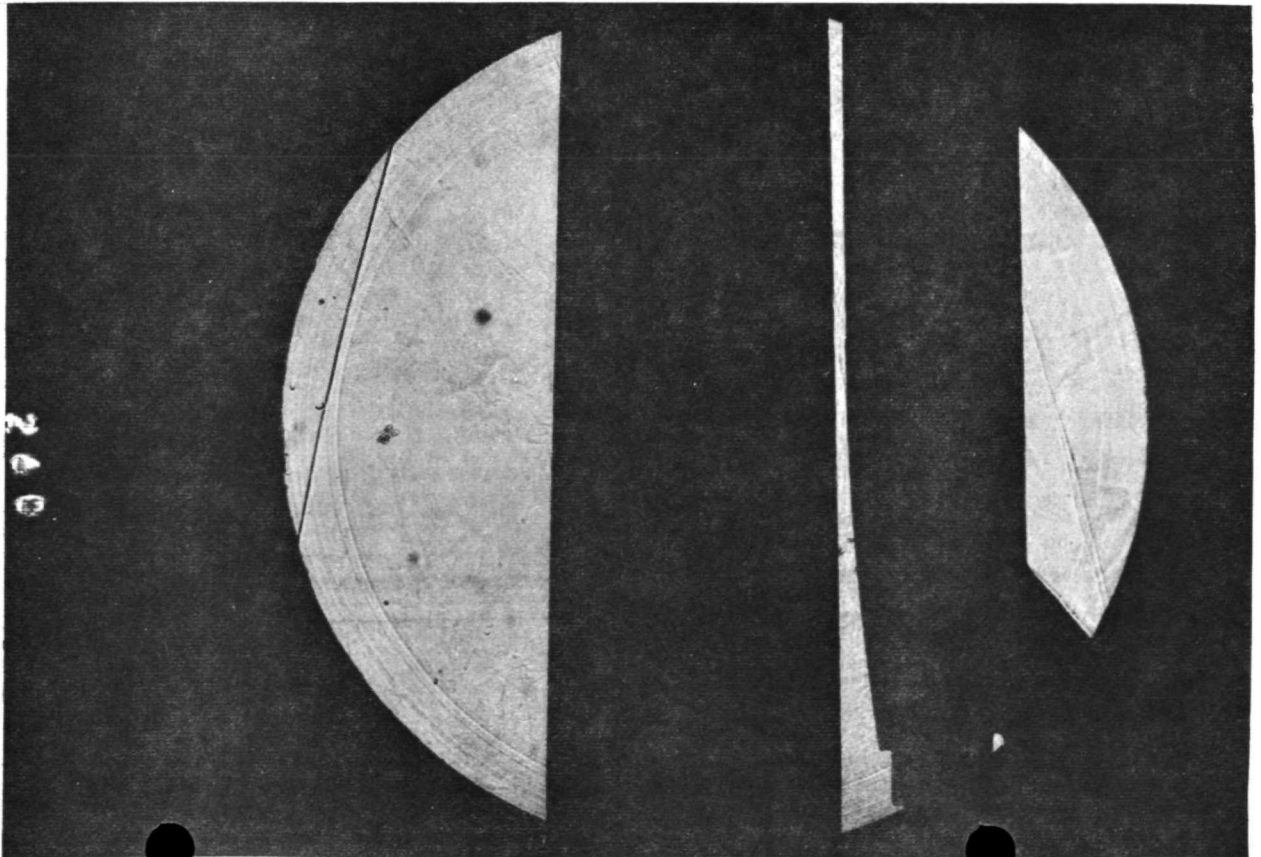

260

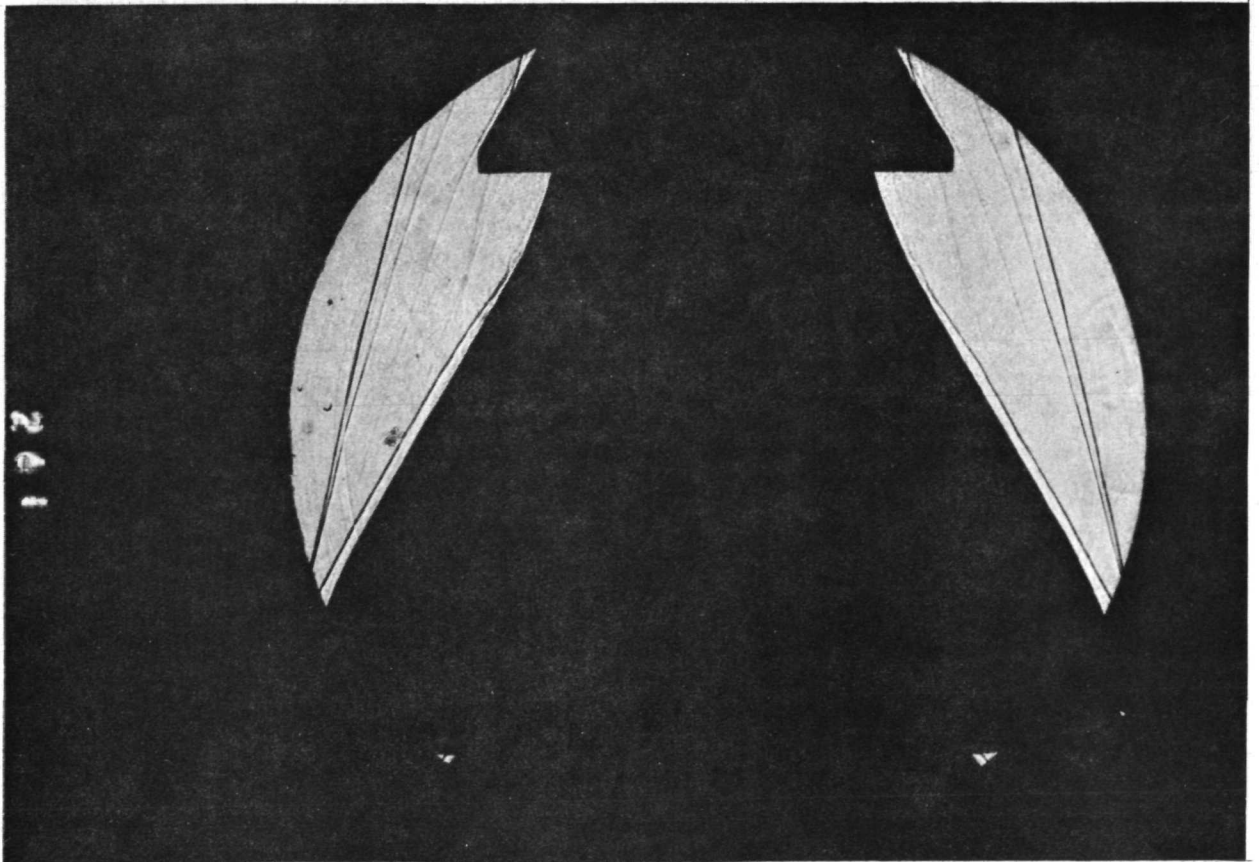
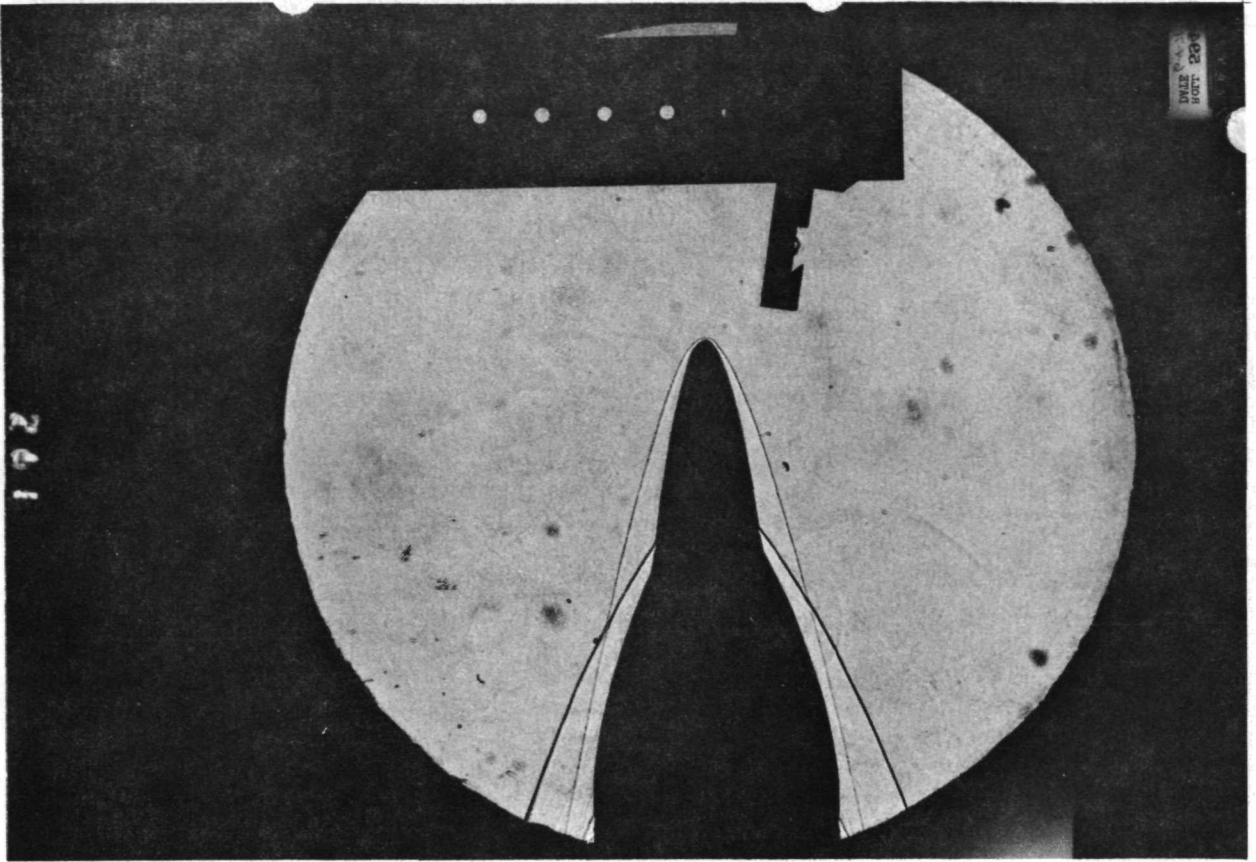

Group 261 Re/ft 2.54 06 ALPHA 0 Roll 90°

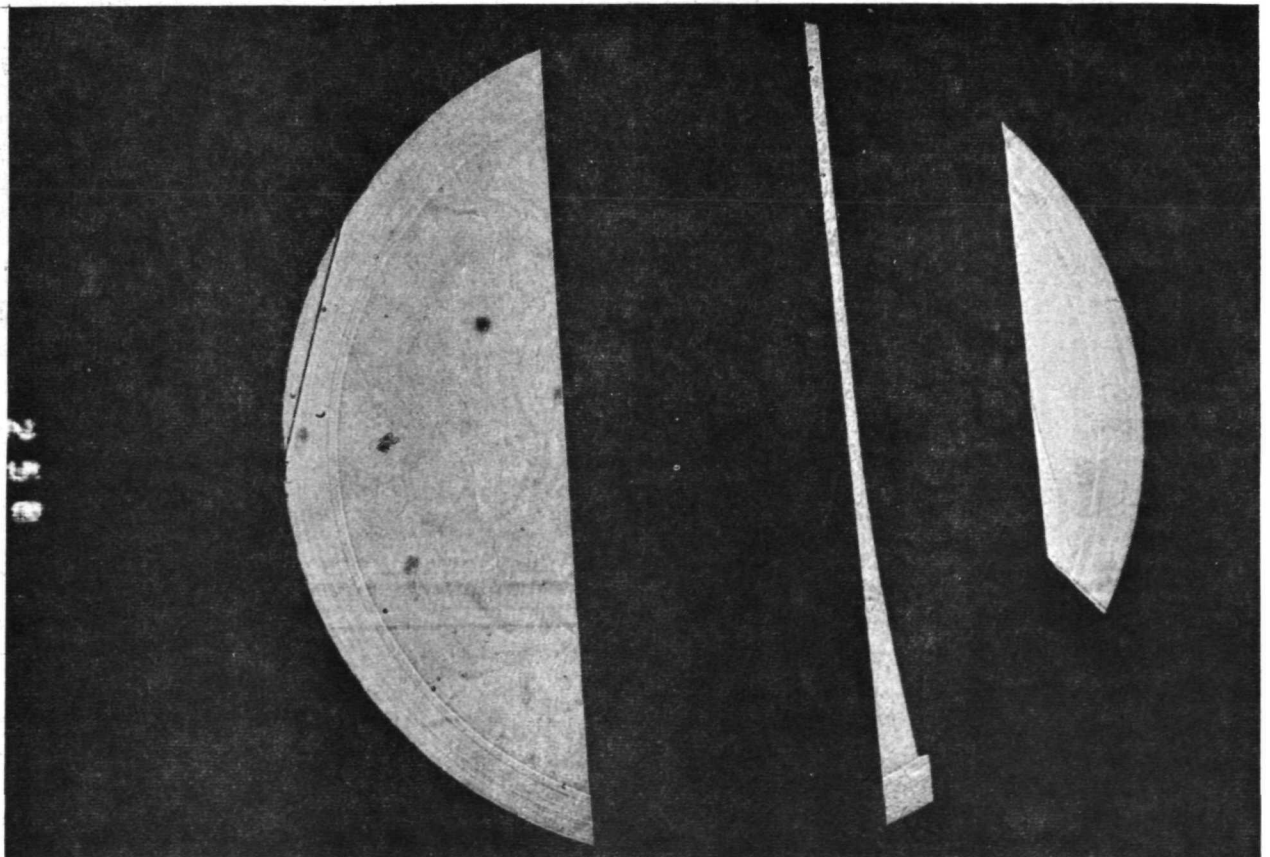
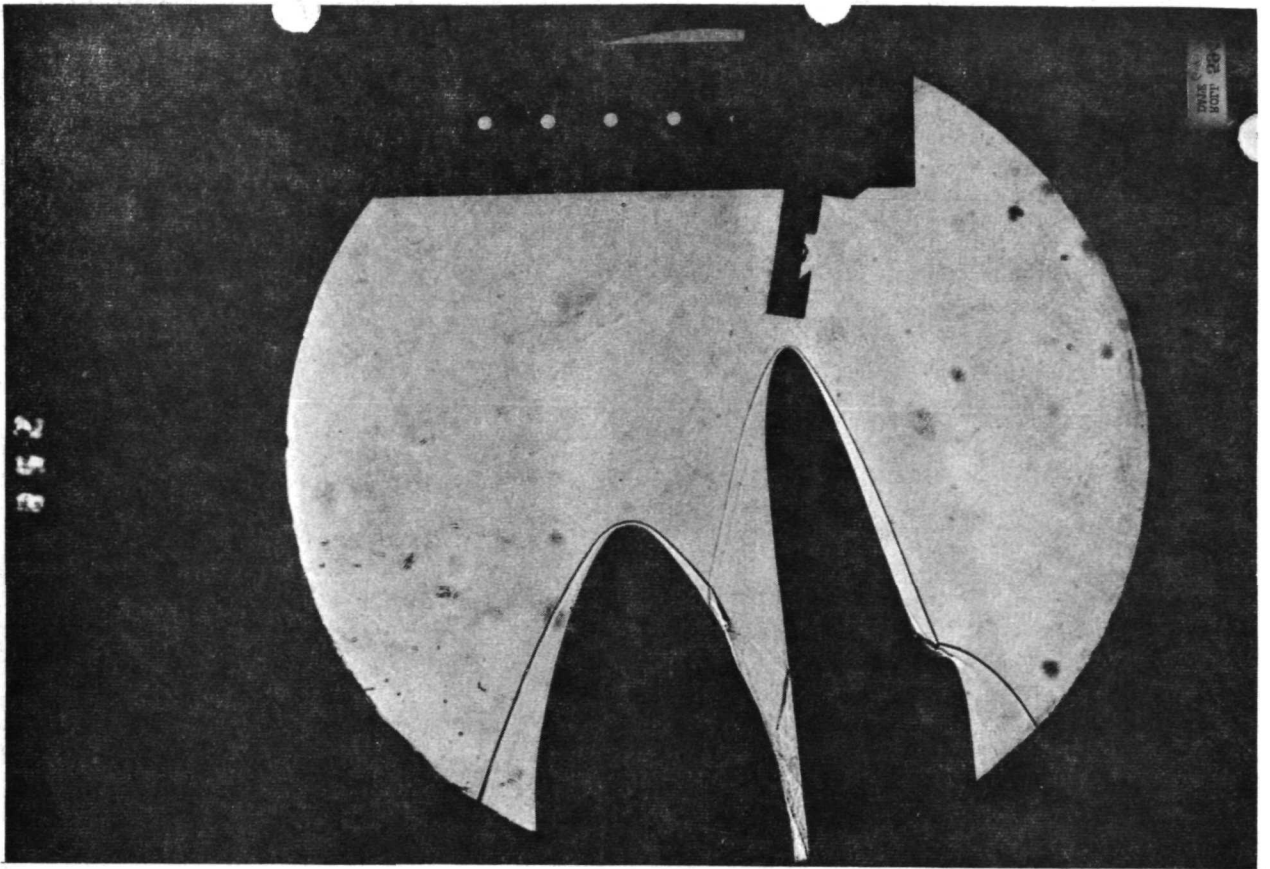

Group 258 Re/rt 2.54 06 ALPHA -5

DATE P.A.
TIME 23

259

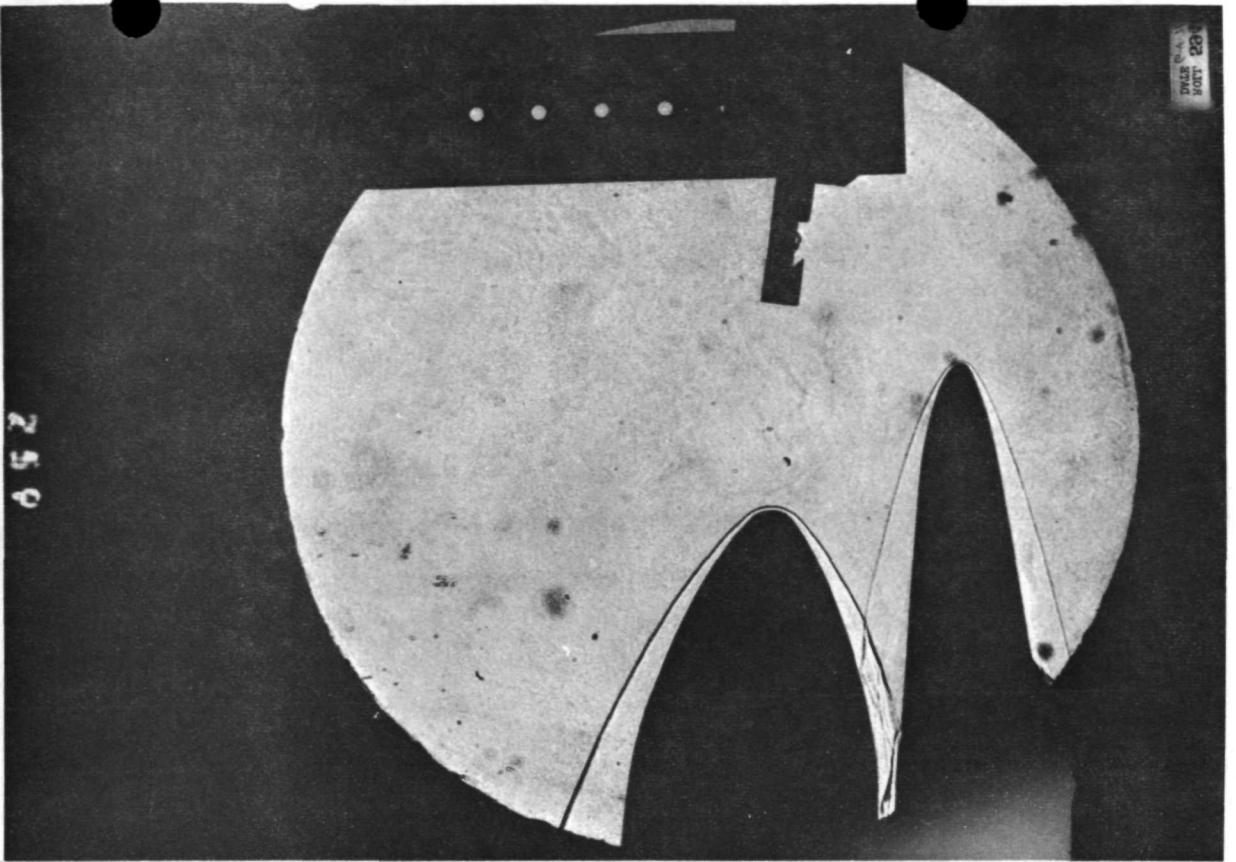

Group 259 Re/ft 2.54 06 ALPHA 5

259

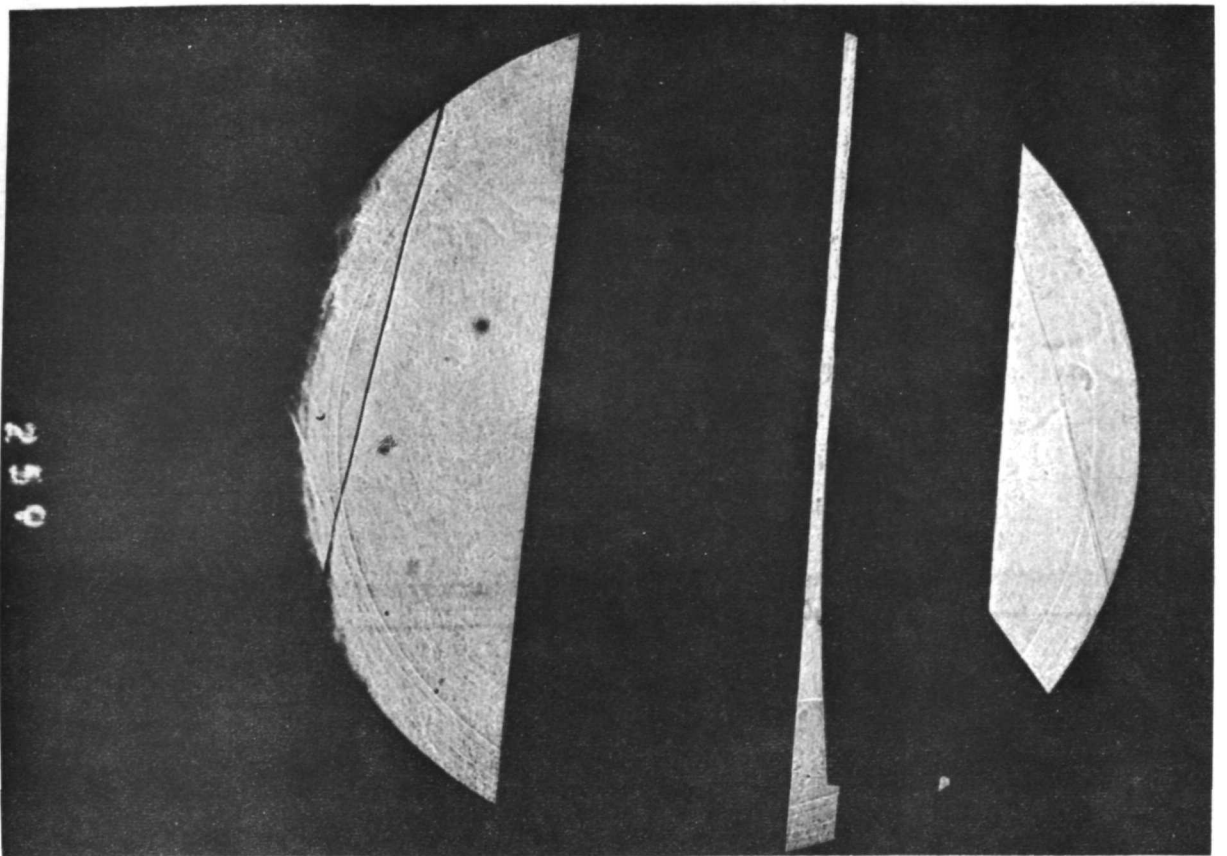

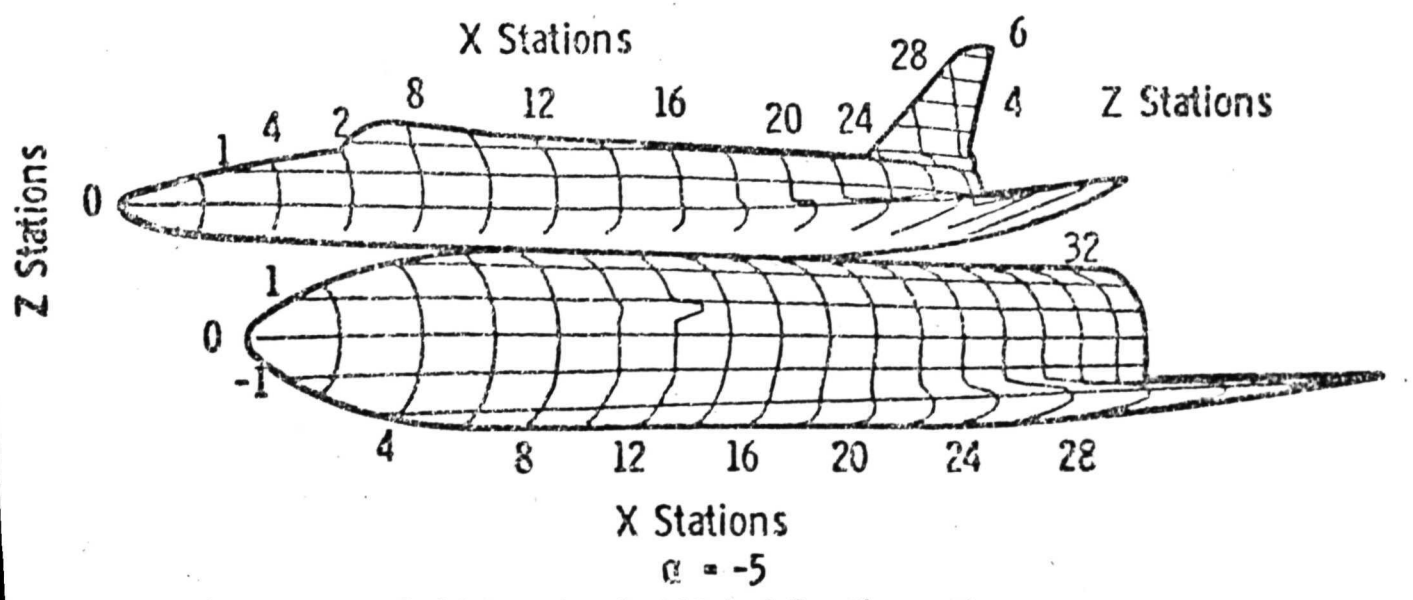
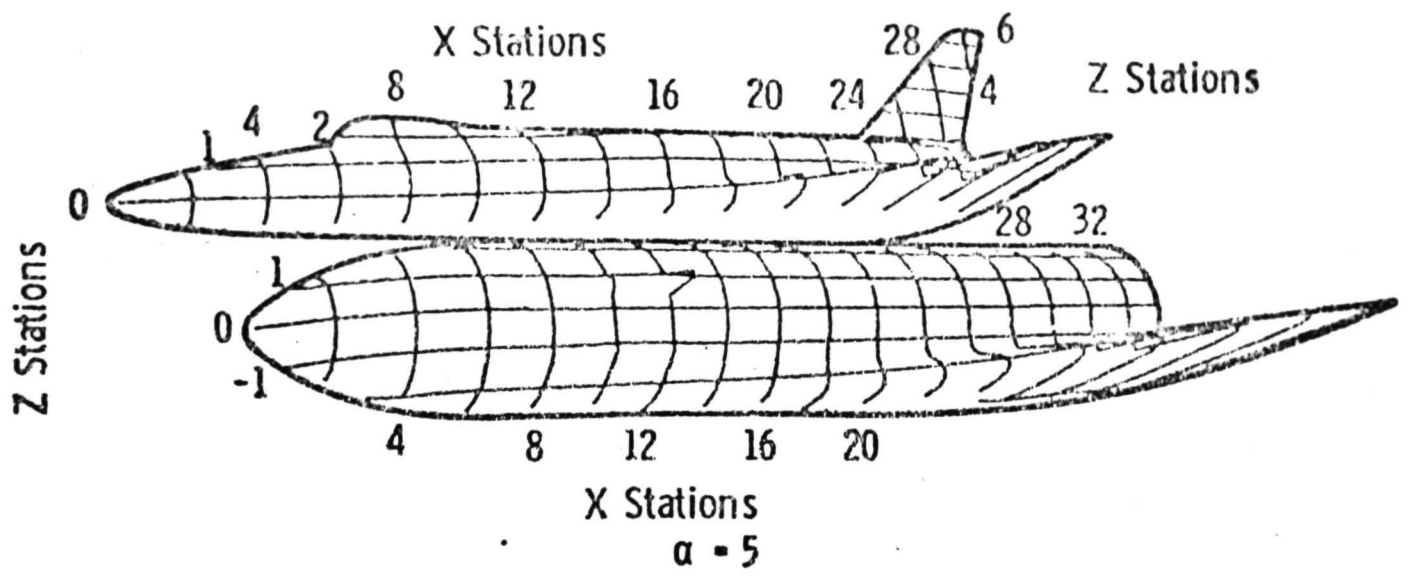
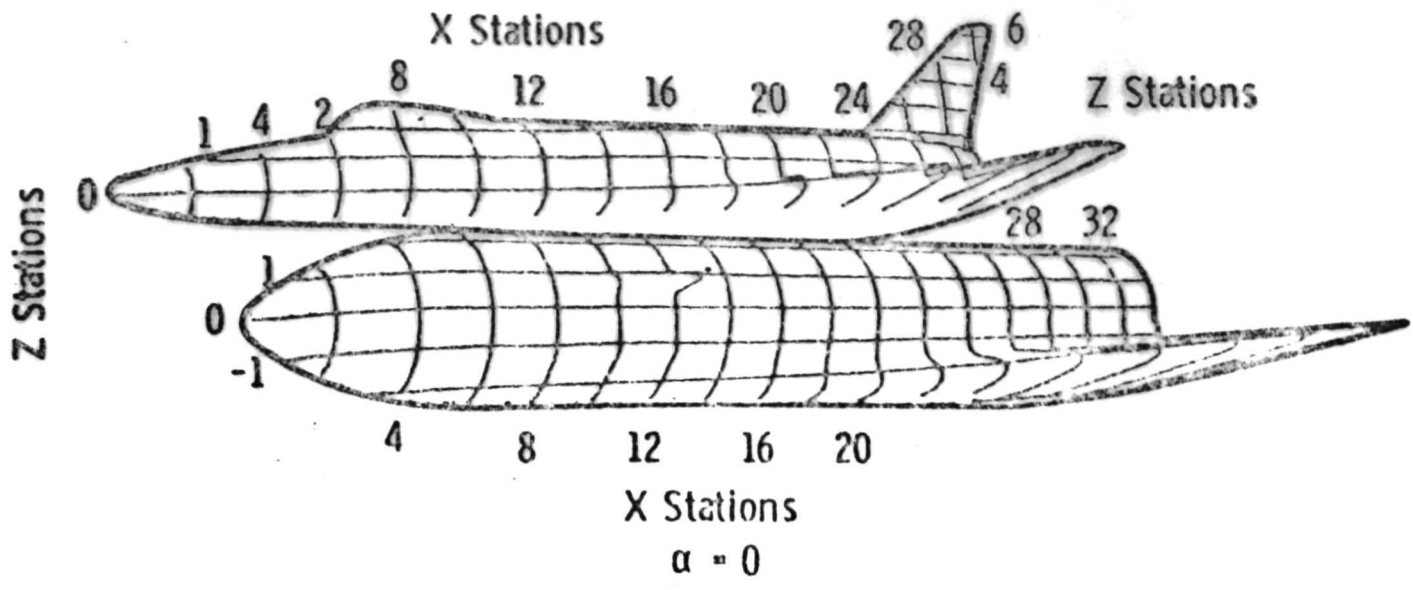

Grid Overlay for Mated Configurations