

File As AD-734158

**MONITORING THE EVOLVING LAND USE PATTERNS ON THE
LOS ANGELES METROPOLITAN FRINGE USING REMOTE SENSING**

Darryl R. Goehring

Department of Geography
University of California
Riverside, CA 92502

Project THEMIS

Technical Report T-71-5
October 1971

ONR Contract #N00014-69-A-0200-5001
Task #N 387-047

and

NASA Grant
NGL 05-003-404

Leonard W. Bowden, Investigator

(NASA-CR-127834) MONITORING THE EVOLVING
LAND USE PATTERNS USING REMOTE SENSING
D.R. Goehring (California Univ.) Oct. 1971
110 p
CSCL 13B

G3/13

Unclas
37222

N72-30318

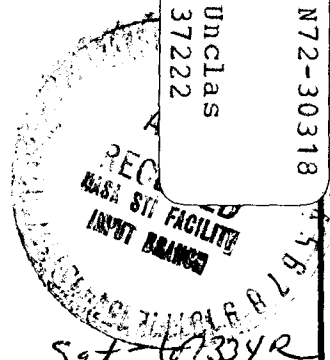

597-6734R

MONITORING THE EVOLVING LAND USE PATTERNS ON THE
LOS ANGELES METROPOLITAN FRINGE USING REMOTE SENSING

Darryl R. Goehring

Department of Geography
University of California
Riverside, CA 92502

Technical Report T-71-5
October 1971

Project THEMIS

ONR Contract #N00014-69-A-0200-5001
Task #N 387-047

and

NASA Grant
NGL 05-003-404

Leonard W. Bowden, Investigator

"Reproduction in whole or in part
is permitted for any purpose of
the United States Government"

This document has been approved
for public release and sale; Its
distribution is unlimited.

I

TABLE OF CONTENTS

Abstract	i
Chapter I - Conceptual Background, Formulation, and History	1
Introduction	1
Purpose and Method	4
Study Area	6
Settlement and Land Subdivision History	8
Chapter II - The Rural-Urban Conversion Cycle: Walnut Valley, California	11
Walnut Valley Land Uses: Agriculture (Plant Crops)	12
Walnut Valley Land Use: Agriculture (Animal Crops)	20
Walnut Valley Land Use: Industry	22
Walnut Valley Land Use: Residential	23
Walnut Valley Land Use: Land Values	28
Chapter III - Rural-Urban Land Use Conversion: A Documentary	33
Land Use in 1953	36
Land Use in 1958: Changes Since 1953	39
Land Use in 1960: Changes Since 1958	43
Land Use in 1965: Changes Since 1960	48
Land Use in 1969: Changes Since 1965	51
Land Use in 1971: Changes Since 1969	55
Evolving Land Use on the Urban Fringe	58
Chapter IV - Urban Growth Theory and the Rural-Urban Conversion Process	65
Urban Fringe Farmers	65
Decision-Making on the Urban Fringe	66
The Value of Accessibility	77
Sinclair Zonation	83
Chapter V - Summary and Conclusions	88
Connections with the Nature of Urban Investment	88
Characteristics of Net Disinvestment	89
Controls on Urban Growth	93
Applications for Remote Sensing Methods	94
References	97
Acknowledgements	101

TABLE OF CONTENTS continued

Appendix A: Agricultural Disinvestment Patterns	102
Appendix B: Urban Land Use Patterns	105
DOD Form 1473	108-9

LIST OF ILLUSTRATIONS

FIGURES

1. Population Growth: Puente Hills Statistical Area	24
2. Annual Population Increase and Number of Family Dwelling Units Authorized: Los Angeles County	62
3. The Urban Fringe: A Disinvestment Zone	69
4. Type of Farmers in the Disinvestment Zone	70
5. Land Values Within the Disinvestment Zone	72
6. Outward Shifts of the Disinvestment Zone	73
7. Determining the Lands "Highest Use": A Static Case	75
8. Locational Utility	78
9. Accessibility Improvement Expands the Zone of Disinvestment	80
10. Accessibility (Locational Utility) as an Inferior Good	82
11. Zonation Within the Disinvestment Zone	85
12. Flow Diagram: The Rural-Urban Land Use Conversion Processes	90

TABLES

1. The Three Basic Land Uses Compared: Walnut Valley Study Area	13
2. Producing Crop Acreage: The Study Area Compared to the Eastern Area	15
3. Crop Values and Yields: Returns per Bearing Acre, Eastern Area	18
4. Subdivisions Recorded-Lots Platted: Puente Hills Statistical Area	27
5. Examples of Land Value Appreciation	29
6. Periodic Land Use	34
7. Land Use Successions - Walnut Valley, 1953-1958	41
8. Land Use Successions - Walnut Valley, 1958-1960	45
9. Land Use Successions - Walnut Valley, 1960-1965	50
10. Land Use Successions - Walnut Valley, 1965-1969	53
11. Land Use Successions - Walnut Valley, 1969-1971	57
12. Summary of Land Use Transactions: By Type of Planning Strategy	60

MAPS

1. Walnut Valley and Vicinity	7
2. Political Divisions Within the Puente Hills Statistical Area	25

LIST OF ILLUSTRATIONS continued

3. Political Divisions, Zoning, and Terrain as Land Value Factors Within the Study Area	30
4. Land Use: 1953	38
5. Land Use Change: 1953-1958	40
6. Land Use Change: 1958-1960	44
7. Land Use Change: 1960-1965	49
8. Land Use Change: 1965-1969	52
9. Land Use Change: 1969-1971	56

ERRATA

- p. 30. Site #3 should be mapped as an industrially zoned parcel. Site 4a is owned by and lies adjacent to a manufacturing firm built prior to 1962. Land values here appreciated less and were appraised at higher value at the outset than other vacant industrially zoned land.
- p. 68. The first paragraph should read: "The nature of urban expansion is determined by at least three basic factors (Sinclair, 1967):"

MONITORING THE EVOLVING LAND USE PATTERNS ON THE
LOS ANGELES METROPOLITAN FRINGE USING REMOTE SENSING

by

Darryl R. Goehring
Department of Geography
University of California
Riverside, CA 92502

ABSTRACT

The urbanization of Walnut Valley from 1953-71 prompted land use change from intensive von Thünen market-oriented patterns to extensive, disinvested, production-factor-minimized patterns. Land owners disinvested as they realized the infeasibility of long-run planning in a situation that became dynamic when a freeway was to be built and the succession of urban uses was assured. Variety in the change was attributed to the different decisions pre-development land owners made as they perceived urban growth incentives and how they timed and selected decisions in keeping with prospects for land sales. Short-run, interim land use planning, has allowed agriculture to persist but only in the form of barley farming and grazing.

Aerial photography used synoptically recorded six periods of land use change that bracketed dates before and after the freeway was announced and built. Interpretations of these changes help recognize potential conversions to urban uses which allow guidelines to be established that deal with rural-urban transition problems before they arise.

1

CHAPTER I
CONCEPTUAL BACKGROUND, FORMULATION, AND HISTORY

INTRODUCTION

Rapid, inexpensive methods of monitoring land use change can greatly facilitate the planning of urban fringe development if one employs synoptic remotely sensed imagery and urban growth theory. Urban planners could stipulate policies dealing with growth early, rather than in increments, e.g. dealing with situations as they arise, if they knew the intentions of land developers and speculators before they initiate formal zone changes and other procedures. Regulated growth could minimize premature urbanization and its associated social and economic costs, stabilize agricultural activities on the fringe, and provide an aesthetic urban boundary. Urban growth converts rural land to urban uses in a series of steps that are evidenced in land use. These steps or processes can be observed and recorded periodically using remote sensing techniques.

Sinclair (1967) helps us recognize these processes on the fringes of American cities theoretically. A von Thünen agricultural zonation does not form beside the typical city (von Thünen, 1826). Zones of production factor disinvestment, inverted from the scheme von Thünen postulates, develop on the immediate fringe in response to the threat of urbanization and the ill-advisement of long-run agricultural investment. Beyond the inner zone or zones, factor intensive zones - dairying, crop farming - are found as in the normal scheme. When the urban periphery expands, economic pressure forces land use patterns of the fringe to change. Land owners make complex decisions. Some may choose: a) to intensify land uses (optimize) and meet the higher operational costs of relative proximity to the developed area; others may, b) disinvest in the existing use pattern as a satisfactory alternative to re-investment; and yet others, c) let urban uses succeed if possible and practical. Decisions depend on many factors, e.g. population growth rates, the availability of interim land uses, and the timing of the proper decision is important in maximizing the benefits of land ownership. One or more steps may be employed before conversion is final and land use stabilizes on long-run terms. Both von Thünen and Sinclair zonation tell us about urban growth, particularly incipient change through intensification and/or disinvestment decisions, the

timing, rate, and character of which point toward the location and imminence of urban succession.

A study by Bourne (1967), with some parallels to this report, describes succession processes in the building stock and associated land use change in Toronto, but does not examine the urban fringe. Fisher and Fisher (1954) originally suggested the theoretical sequence through which such changes might occur. Evolution of the transition zone illustrates how succession operates and how land use change may be involved: residential land near the urban core is invaded by an expanding CBD, operational costs rise, and land owners may tend to intensify the structure's use. Change begins with the size of the spatial unit (single family to multiple family use) and the building becomes crowded without changing the basic land use. Carrying costs are met until a change in the type of use is necessitated, the second stage, which may include some structural alterations. Land use, however, does change significantly. Eventually the building is replaced when new investment, private or public renewal, is made. One major succession cycle is then completed for the building stock and the central city is redeveloped, Bourne's major interest. Bourne emphasized the use of public record data which contains the facts that interested him. Remotely sensed data could not monitor the land use changes he observed which were largely within the structure. On the rural-urban fringe, remote sensing can be a primary data source for a similar study in urban dynamics. Land use changes tangibly and few public sources record these facts. Changes in land use may represent steps in the rural-urban conversion process that parallel the changes of size, type, and replacement that represent how inner city patterns evolve. There are other similarities. Both studies show the term, net disinvestment (Wingo, 1966), applies as an important interim land use strategy although Bourne does not give it emphasis. Filtering is the term economists and sociologists give to a kind of residential succession in which net disinvestment is key: land use intensifies (crowding), and with the lack of input of the necessary production factors, deterioration follows (capital disinvestment). Buildings are occupied by families of successively lower socio-economic status. Land use intensity ascends insofar as factors of production can be manipulated in the short run, but by minimizing capital inputs, the market answers the infeasibility of long-run maintenance of the existing land use and the particular structure.

Only when market conditions or public intervention warrants it will the use be replaced or succeed to a higher land use (Grigsby, 1963).

Rural-urban land use conversion is a special case of the above. Bourne's three processes - change in size, type, and replacement - are manifest differently due to the lack of an inertia that lies in major capital investments such as a building stock. While the urban property owner changes in size, his rural counterpart intensifies and plants a higher return crop, conditions permitting. Capital may be invested in irrigation, fertilizers, and cultivation, but he plans for short-run returns when compared with the urban land owner. When he cannot justify even short-term investment he disinvests in the existing pattern or disinvests relative to others who intensify. Given agriculture's extensiveness and shorter planning horizon, the above stage develops rapidly and tangibly as a widespread agricultural blight or underfit use where potential is unrealized. Agricultural types were changing through the above two phases, and the only equivalence for replacement is when urban uses finally succeed. Problems are similar, but some of the characteristics are different and distinctive. Agriculture converts to urban uses and urban uses succeed to other urban uses. Both are dynamic processes of urban growth that involve reduced investment as an interim land use alternative.

Dynamic change may be studied in a region where urban uses become more feasible than agriculture due to accessibility improvement. Mere knowledge of where the future roads are to be built affects the landowner decision-making process. Accessibility, improved locational utility, allows for greater spatial interaction and lets real estate costs, or rents be bid upward and economic space reordered along new lines (Janelle, 1970). Market-oriented intensive agriculture is threatened by the invasion of higher, urban land uses. Land speculation is rife, sporadic urbanization follows, and then the interstices fill. Fringe development proceeds much as follows: prospective real estate developers and builders are attracted to cheaper land in the more spacious rural environments of outlying areas. Land uses gradually become incompatible and agricultural efficiency is jeopardized as more farmland is progressively converted to urban use (Roterus and Hughes, 1948). Factor disinvestment becomes the norm for agriculture in the unstable investment situation. There is interim land abandonment, use decay, and substitution of less for more capital intensive agriculture. Extensive land use patterns

replace intensive patterns (Gregor, 1970). The first wave of urban development accepts whatever services rural government provide. Further urbanization makes demands of the service system - roads, water and sewage systems - and incorporation is sometimes forced to solve these problems, or services may be extended from developed areas at high cost. Once a commitment is made, i.e. greater public investment, the area develops rapidly, but only after the initial period of high economic and social cost (Sermonti, 1968).

Public works projects, particularly roads and service systems, undoubtedly influence the rate and direction of land development. Whole regions feel their impact; regional growth or decline is often directed. Public works projects, such as the California Water Project, are often responses rather than anticipations of private demand despite what the advocates propagandize. They are rarely stimulated through well-conceived regional development goals. Governments contribute to urban sprawl when these projects lack overall development plans that order and control the regional growth that follows. Comprehensive planning, unfortunately, is done ex post facto by the summing of plans by smaller agencies who are responsible only for segments of the total development. Part of the problem is that a project affects a region uniquely, as an expression of the interplay of economic, institutional, and environmental forces. This must be learned for each region, or at best, predicted, and no one agency has overall justification for planning and total competence to discern these forces. How projects are influencing growth can be discerned as it happens, however. Urban growth theory tells us how rural-urban land use conversion processes operate; remote sensing techniques such as aerial photography permit the precursors of conversion to be examined through time. This makes possible the development of timely policy recourses which can direct rather than respond to growth neither belatedly nor incrementally.

PURPOSE AND METHOD

Urban growth theory when married to a means of describing and systematically mapping land use change sequentially provides a basis for planning the urban fringe. Static situations need not be observed periodically, but those which change and show variegated changes that relate to decision-making and other influencing factors can well justify synoptic observation. An example is used with its own special conditions and history. Identifying the process and

the induced change helps predict subsequent change. Lessons in urban growth processes can be learned as theory and practice are here blended.

The above postulate treats dynamic urban change which resulted from improved accessibility. Innovations in transportation let economic space continually be reordered and locational choice and development potential be enhanced or limited differentially. Road construction increases the available land supply and the market price of land in the entire region is affected. Site character becomes a more important value additive than situational character (Hoyt, 1960). Leap-frogging development is encouraged, and the ease with which communication becomes possible from outlying areas creates from a dense freeway and surface road network a near isotropic transportation surface where the only other value peaks are at intersections. Emphases on site in the development process, and land surpluses, point to the need to plan the development of newly accessible regions and to regulate land use conversion in an orderly fashion.

Aerial photographs are utilized to compile land use maps for different periods before and after the completion of a road. After mapping the complete land use of the earliest period, only change is recorded in subsequent maps. Data, measured by planimeter, are recorded for each period so that a current compilation and land use map can be easily constructed. By a materials-balance technique, types of land use input to and output from the rural-urban land conversion process are recorded, and studies are made periodically of the nature of these events (with a civil or political division overlay, this can be done for small areas). Parcel histories can be determined but in most instances they are obscured when the use does not conform to property lines. The object is to examine whether the set of events of intensification and/or disinvestment are precursors of land use succession in a chosen study area and to explain their occurrence by urban growth theory - concepts in land economics and locational theory. These events may differ because of site characteristics and by the amount of prior investment into the land, all of which are peculiarities of the geographical situation considered. From this determination it will be shown that Sinclair zonation exists in the test site and that a somewhat predictable sequence of events takes place in the conversion of land from rural to urban uses that is easily recorded with a number of research tools, particularly that of the remote sensor.

STUDY AREA

In 1955, plans were disclosed to connect outlying Pomona in eastern Los Angeles County with the remainder of the Los Angeles Metropolitan Area, thirty miles distant, by a freeway through Walnut Valley (Map 1).¹ Private and public decision-making processes accelerated and still the region is not yet filled. Urban fringe land uses are evolving to urban uses, the conversion being so recent as to have been documented by aerial photography.

Photo coverage begins in 1953 with that of the Soil Conservation Service, United States Department of Agriculture, which documented the land use just prior to the announcement of freeway development plans. Two other general sources are used, private and public agencies, to recognize change since the initial survey: in 1958, 1960, 1965, 1969, and 1971.² All imagery,

¹Walnut Valley is oriented east to west and lies south and roughly parallel to the much larger San Gabriel Valley, from which it is separated by the San Jose Hills, a northern outlier of the Puente Hills Block that defines the watershed boundary between the drainage of the Los Angeles Basin and the Santa Ana River. Map 1 delineates this Block, as a line along the westerly boundary of the City of Pomona to Prado, and on the west by a line from Whittier southeastward to the point where the San Bernardino-Orange County boundary crosses the Santa Ana River.

The Puente Area is a folded region made up of unconsolidated sandstones and shales geologically similar to the Santa Ana Mountains. Walnut Valley lies within the Block, one of its synclinal valleys, and is occupied by the San Jose Creek which drains westward through the adjacent La Puente Valley and into the San Gabriel River. Coalesced alluvial fans from the bordering San Jose and Puente Hills have formed a two mile wide Valley with one to three feet of more or less friable, permeable, and level soils of good agricultural potential. Situation offers the region distinct advantages as against the likelihood of Santa Ana wind damage and has supported arboreal culture here, hence the name "Walnut Valley."

²With one exception all photography was taken in the same season of the year: 1/2/53, United States Department of Agriculture, Soil Conservation Service, 1:24,000, Black and White; 1/15/58, Geotronics Inc., Long Beach, California, 1:31,500, Black and White; 2/13/60, Geotronics Inc., 1:15,000 Black and White; 9/21/65, United States Department of Agriculture, Soil Conservation Service, 1:24,000, Black and White; 1/15/69, Regional Planning Commission, Los Angeles County, 1:24,000, Ektachrome Infrared, Type 8443; 3/30/71, National Aeronautics and Space Administration, 1:60,000 and 1:120,000, Ektachrome Infrared, Type 2443.

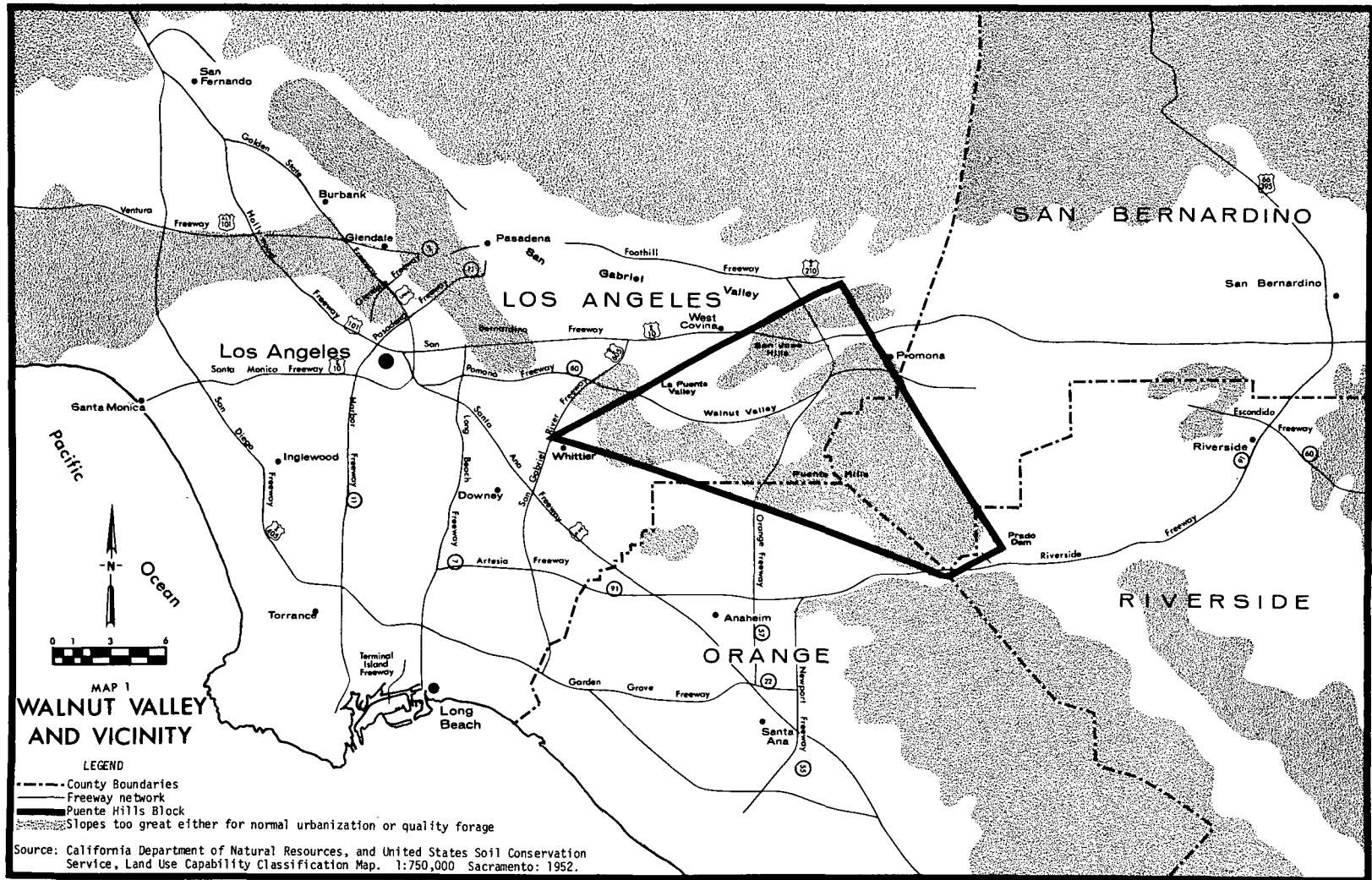

except for the last two surveys, was in black and white format. Ektachrome Infrared, Type 8443, film used in 1969, and Type 2443 in 1971, greatly facilitated the recognition of still-existing agricultural patterns.

Walnut Valley remains the only important agricultural area in the Los Angeles Basin. Not all the valley need be studied, however, since it would not be necessary to satisfy the postulates put forward. The part selected, approximately 60 square miles, includes pre-1950 land use remnants as well as newer patterns. A simple delineation based on topographic boundaries suffices as a study area. East to west, north to south cross sections include urban fringe uses gradating eastward from Los Angeles and also terrain-modified land use.

Urban activities did not evolve rapidly in Walnut Valley. Their succession was preceded by land use intensification and disinvestment processes. Chapter One describes the purposes of this report and the settlement and land subdivision history. Chapter Two discusses the results of the conversion processes as they appear in agricultural data - crop acreage, value, and yield data. Secondly, other land uses will be discussed as results of these processes. In Chapter Three, aerial photographs are used to document the status of the overall-rural-urban conversion event, and in Chapter Four urban growth theory is applied to the subject in question. Chapter Five summarizes and concludes the above report and is followed by a photo appendix.

SETTLEMENT AND LAND SUBDIVISION HISTORY

Walnut Valley served historically as an easterly corridor to the Los Angeles Basin (Kemler, 1940). Portola's 1769 expedition gave the name (oldest in the County) "La Puente" to denote a site on the San Jose Creek where the miry banks necessitated a bridge of poles to cross this "broad and spacious plain," (Bolton, 1966). Transportational functions were emphasized in the 1850's with the establishment of the Butterfield and other stage routes, in 1874, with the laying of the Southern Pacific rail lines, and again, in 1902, when the Union Pacific lines were built less than a mile south of the earlier right-of-way. Electrification came in 1910, and roads and a concrete bridge followed, giving connection to the growing urban centers around the mission San Gabriel Archangel and the city of Los Angeles.

Rancho San Jose, the greater portion of the study area, evolved in the 1830's when the mission's lands were secularized. Cattle, hides, and tallow were mainstays of the economy until wheat became profitable with California's growth after 1850. Specialization developed in grain crops, viticulture, and grazing until newer crops were introduced fifty years later.

Walnuts of the Placentia variety were introduced in 1906 and budded onto the local black walnut (Juglans californica). Air drainage sites along the San Jose Creek were preferred to the adjacent, much larger, San Gabriel valley where wind damage was likely and warmer winters precluded most deciduous tree crops. Medium-textured friable soils, six feet deep, on level and irrigable sites were plentiful along the creek banks. By 1937-38, forty percent of the Puente area (6,750 acres) was devoted to walnuts (Nevins, 1951).

Citrus tolerated the extensive alluvial fans of the Puente Hills' northern slope better than other crops. Land developers promoted a citrus-raising residential-agricultural development after 1913 on small lots (10-20 acres), merely extending already flourishing districts to the south and west. Valencia oranges were seasonally compatible (maturing in the spring and summer) with the fall-winter navel orange raised on drier sites. Eureka lemons and some grapefruit occupied higher fan slopes. Wind damage was reduced by eucalypt plantings; avocados served a similar purpose and on a commercial scale (Fuerte var.) they were also profitable. By 1937-38, 2,750 acres of citrus and 350 acres of avocados were planted (Nevins, 1951).

Widespread agricultural decline in Southern California after World War II resulted from population growth and suburbanization, and changing economic conditions, and forced the industry to readjust, particularly its arboreal culture phase. Intraindustry competition with Florida in orange and grapefruit culture and a poor foundation for reinvestment in citrus when necessary - the scarcity of insecticides in the war years and resulting tree damage, the problem of quick decline - justified little further investment given the high replacement costs for citrus and walnuts. Avocados replaced some lemons and acreage increased slowly. Walnuts did not survive the readjustment (Thompson, 1961). Yields declined after the 1930's. The climate was not cool enough, a series of warm winters damaged many groves, insect pests were drawn by the above condition, and the general costs of irrigation, fertilizers, and pest control were rising. By 1950, only 2,895 acres were producing and

2,060 acres had been subdivided (Nevins, 1951). Growers lacked experience in other types of farming. Some cleared land for leasing to row crop farmers. Others raised field crops until they acquired row crop experience and the area took on characteristics of truck farming. Some die-hards continued with walnuts; many sold out to land speculators. Since 1946, row crop acreage increased nearly as fast as walnut acreage decreased (Nevins, 1951). Citrus survived the initial adjustment since values and yields remained high and land use change could be resisted; marginal land, however, was eliminated. It became clear that agriculture faced stiff competition both in land use and within its own industry.

Row crops, however, were not the final answer. To a considerable degree, crop selections were the result of their resistance to smog, particularly the aerosol phase, which is often prevalent (Jacobson and Hill, 1970). Many of the smog-sensitive leafy tuberous vegetables - carrots, table beets and turnips, and the "open foliage" types such as romaine lettuce, spinach and endive, are not grown in the area. Compact leafy vegetables - head lettuce, cabbage, or vegetables not dependent on outer leaf appearance for marketing, such as cauliflower, cucumbers, and onions - are grown. An annual planting sequence had been developed. Lettuce and cabbage were planted for year-around harvest. Cauliflower was raised for winter harvest and onions or cucumbers and occasionally tomatoes or cantaloupe for the summer market.

By 1950, the beginning of the study period, agricultural land use was quite closely adjusted to terrain. A valley cross section shows grazing on the higher relief of the San Jose and Puente Hills, and wheat and barley grain crops on gentle, rolling terrain, all relicts of 19th century patterns. Arboreal culture, citrus, occupied fan slopes on both hill areas, and walnuts are grown on the level valley floor. Field crops are extensive, particularly in the western sector of the study area, and walnut groves, where decline set in, were converting in use to row or field crops and some urban use attached to the expanding Los Angeles fringe.

CHAPTER II

THE RURAL-URBAN CONVERSION CYCLE: WALNUT VALLEY, CALIFORNIA

Clearly, many forms of agriculture were on the wane in southern California by the end of World War II. Marginal producers had several choices to their common problem: 1) substitute specialized, higher return crops if economic conditions allow it (intensify); 2) sell out (disinvest relative to others who intensify) and let others decide (?); or 3) absorb the fixed costs of land holding and offset them with marginal production (disinvest). A fourth alternative, a complete conversion, or allowing urban uses to directly succeed agriculture without passing through any of the above stages, was momentarily unfeasible. Many marginal producers preferred to sell out for urban use, but the time was not "ripe" because the urban fringe had yet to reach them. In the Walnut Valley, a regression to extensive grain farming and grazing rather than intensive agriculture seemed feasible as interim uses until alternatives were available.

Grain farming serves several purposes simultaneously: California State Law (Public Resources Code Section 4291) requires acreage within 30 and in some cases 100 feet of occupied buildings to be cleared of natural, flammable vegetation to minimize fire danger. Grass and other vegetation beyond this distance and less than 18 inches in height above the ground may be maintained where necessary to stabilize the soil and prevent erosion. Barley fields were an economic cover crop, not a valueless natural grass or weed succession. They could be farmed in an efficient cycle typical of Sinclair disinvestment zones and were raised not only in the fire buffer zone but elsewhere on the Valley's larger acreages: tenant farmers planted and dry-farmed, fall-sown small grains for harvest in the spring and summer. Grain straw was baled and sold. Migratory herders followed with truck-borne sheep to graze the stubble fields. On steeper terrain intermixed volunteer grasses, domesticated and natural, were occasionally mown for hay besides being grazed. A land owner realized no capital outlay on his holdings, neither to cultivate nor to maintain/abate grasses and weeds. In fact, a small profit helped offset holding costs.

Industrialization was considered as an alternate land use long before World War II. Two rail lines, a truck route, and much inexpensive land

provided unique opportunities. As residences sprawled in the 1940's, hope increased that the more preferred industry would develop Walnut Valley and intensified agriculture progressively became less feasible. Major property interests organized smaller landowners soon after World War II in a petition to have the area incorporated as an industrial city. In 1955, an amendment to the State Master Freeway Plan showed a route to be built through the valley in ten years. Los Angeles County, in a Master Regional Plan (Regional Planning Commission, 1955), recognized the region as a possible companion to Vernon and the City of Commerce, older industrial satellites to Los Angeles that were built in the 1910-20 and 1940-50 periods, respectively, and represented industrial demands of those periods. A modern, better functioning counterpart was needed for the 1960-80 expansion period that would lead regional development. The twelve square miles of level terrain in Walnut Valley offered much to satisfy growth potential; it had most of the necessary prerequisites.

In 1957, development plans for Walnut Valley were realized in the incorporation of the City of Industry. Many landowners, particularly those who acquired land for investment, found it beneficial to become part of the new city and did so in a series of annexations during following years. Level terrain near San Jose Creek, below Valley Boulevard (the truck route), was annexed and preserved under sweeping industrial zoning, prompting the City of Walnut to incorporate in 1959 in self-defense.

Periodic Land Use Data

In the six periods examined with aerial photography between 1953 and 1971, land use change was dramatic. Agricultural functions declined considerably (less 4,719 acres) and were replaced almost equally by urban functions. Unused, vacant land conversions to urban or other land uses were minor (only 967 acres). In these terms, almost twice the existing urban land use can be sustained by converting the remaining agricultural land (Table 1).

WALNUT VALLEY LAND USES: AGRICULTURE (PLANT CROPS)

Farmers in the Walnut Valley were grateful for the post-war period that enabled ridding themselves of poorly producing acreage. They generally

TABLE 1

— THE THREE BASIC LAND USES COMPARED: WALNUT VALLEY STUDY AREA
(in acres)

<u>Land Use Type</u>	<u>Survey Date</u>					
	1953	1958	1960	1965	1969	1971
AGRICULTURE	13,353	12,439	11,675	9,534	8,921	8,634
URBAN	1,007	1,999	2,892	5,433	6,258	6,802
residences	228	821	1,726	3,554	4,016	4,417
industry	66	215	324	523	740	755
commerce	6	9	9	43	71	100
recreation	0	0	39	341	363	363
institutions	156	166	166	279	373	373
agriculture	230	271	267	287	264	264
vacant*	321	517	361	406	431	512
VACANT	22,353	22,585	22,456	22,056	21,944	21,686
TOTAL LAND AREA	37,023	37,023	37,023	37,023	37,023	37,023

Source: Aerial Photo Interpretation.

Notes: *Land that has been prepared for urban use - graded and leveled for impending construction.

hoped that the subdivision boom would subside and permit industry to develop in the Valley. They intensified agriculture by expanding feed lots and dairy activities. What passes for intensification in other instances - the conversion of poorly producing and declining groves to higher return field and row crops - was not a decision to reinvest in long term arboreal culture and a disinvestment measure in long-run terms. This alternative became common. Agriculture intensified in the short-run in lieu of long-run reinvestment. Walnut Valley lingered from World War II onward as a marginal producer. Acreage figures (Table 2), beginning with 1956, show continual decline.

Acreage Devoted to Agriculture

Figures for the exact study area were available only by adapting several dot map analyses of the subcounty (Eastern Area) reporting area production. Walnut Valley's share of regional output would be similar in all periods if the study area in 1957 can be fairly compared with the Eastern Area in 1958. In Citrus Fruits the Valley had one-fifth the acreage of the reporting area because it was only one of many districts of that larger area, e.g. the Covina, Pomona and other districts are included.¹ Walnut Valley had half the total acreage of Other Fruits and Nuts, and virtually all the Field and Vegetable Crops. It is also one of several producing districts in Nursery Stock and Cut Flowers. Therefore, the valley is subregionally specialized in Field and Vegetable Crops and to a degree in Other Fruit and Nut Crop production, and shares proportionally in other crops.

Urbanizations' inroads are shown in the precipitous decline of Citrus Fruits from 1958-70. Valencia oranges, a crop once extensive in Walnut Valley, declined most of all. Lemons are less dispensable in Southern

¹Being the only area with extensive agriculture left in the Los Angeles Basin, the Eastern Crop Reporting Area, essentially Walnut Valley, today dominates the production of several commodities. For example, in barley, while the rural Antelope Valley on the desert fringe of the San Gabriel Mountains is the primary producing area, the much more urbanized Eastern Area produces 36.2% of the Los Angeles County total (12,400 acres). Citrus fruits are more concentrated. The Eastern Area has 666 out of the remaining 778 acres of Navel oranges in Los Angeles County, 429 out of 1,305 acres of Valencia oranges, and 1,344 out of 1,605 acres of lemons.

TABLE 2

PRODUCING CROP ACREAGE: THE STUDY AREA COMPARED TO THE EASTERN AREA (in acres)

CROP TYPES	Selected Dates			Date of Photo Survey				
	1956	1957	1964	1958	1960	1965	1969	1970
CITRUS FRUITS			900					
Valencia oranges	2,700	1,500		4,330	3,323	1,458	526	429
Navel oranges	700	300		3,525	2,947	1,428	828	666
Lemons	1,300	600		3,775	3,746	1,975	1,490	1,344
OTHER FRUITS & NUTS			500					
Walnuts	2,300	800		1,225	1,030	278	--	--
Peaches	100	--		17	19	13	--	--
Grapes	100	--		--		--	--	--
Avocados	800	300		740	893	755	430	426
FIELD CROPS			8,860					
Alfalfa hay	500	300		500	400	500	300	280
Sugar beets	100	--		60	--	--	--	--
Grain, Barley	4,000	3,000		3,000	3,500	5,200	5,000	4,500
Grain, Hay	2,400	2,000		2,000	1,800	2,000	1,200	1,200
Grain, Oats	200	230		230	--	--	--	--
Grain, Wheat	--	300		300	300	--	--	--
Irrig. Pasture	2,000	1,800		2,000	900	400	350	350
Dry Beans	--	1,200		1,200	500	100	--	--
VEGETABLE CROPS			100					
Cabbage	300	--		250	50	30	10	10
Cauliflower	--	100		150	150	50	15	15
Chinese Foods Veg.	--	100		150	25	--	85	40
Dry Onions	200	--		60	--	--	--	10
Carrots	100	--		200	130	50	20	--
Tomatoes	--	60		--	--	--	--	--
NURSERY STOCK & CUT FLOWERS			100					
Cut Flowers	--	--		50	75	50	55	62
Nursery stock	--	100		500	500	750	528	633

Source: Data for 1956, 1957, 1964, are from dot map analyses, the only available data for the exact study area. Excepting 1953 data which was unavailable, data for 1958, 1960, 1965, 1969 and 1970, were from the Plant Crop Report for the Eastern Area, all published by the County of Los Angeles, Agricultural Commissioner.

California agriculture. There are definite environmental advantages for lemons relative to other producing areas nationwide. Hence, they withstand acreage decline better.

Other Fruits and Nuts, predominantly Walnuts, have virtually disappeared from Walnut Valley in the past decade. In one year alone, 1956-57, 1,500 acres were removed in Walnut Valley, and by 1969, the conversion cycle had been completed for at least one crop in all parts of the Eastern Area reporting district. Avocados are raised in a residential-agriculture suburban (5 acre lot) housing pattern which is protected by zoning and resists land use change.

Field Crops hold their own but their extent is slightly declining as areas become urban. As barley is not a USDA restricted crop, the practice of raising it for ground cover and as an interim use has become so workable that the only important activity areally stable is its cultivation. Barley and grazing remain unchanged, whereas alfalfa, irrigated pasture, and dry bean crops, requiring greater capital inputs, declined much more, e.g. reduced to one-sixth in twelve years.

Vegetable Crops decreased greatly. Smog has been one factor, but whether such limited acreages are significantly related to environmental or economic trends or to inertia, i.e. a tradition, cannot be answered adequately in the present analysis.

Market, demand and locational considerations influence the acreage devoted to Nursery Stock and Cut Flower production in such a manner that they compete for space with typical urban uses (Gottman, 1961). They can be called an "Urbanized Agriculture" because of the intensiveness of factor inputs and commercial scale of production and marketing that permits them to coexist with dissimilar land use and high operational costs. Nurseries reveal these characteristics better than Cut Flower data. Nursery production is so commercially oriented that it enlarges with the population. In the Eastern Area this was true when nurseries increased from 1960-65 with the main population growth, perhaps to the extent of creating an over supply. In 1966 there were 700 acres, but a readjustment is indicated in the acreage decline to 450 acres in 1968. As the population continued to grow, acreage increased through 1969 and 1970.

Crop Value Trends

Crop values favored Citrus Crops through the 1950-60 period. That is, if one farmed on the basis of gross returns per acre, citrus would tend to be emphasized since only several row crops could displace it on a value basis (e.g. onions and tomatoes, 1946-50, were worth \$558 and \$621 per acre, respectively, as compared to Valencia oranges, \$445, Table 3). Conversion seemed unlikely given the relatively high return, and even a lower or declining return could be tolerated for a while when land clearance and preparation costs and the need for new technologies were considered. Existing trees were aging, however, and a major investment decision had to be made soon. While citrus outproduced other crops absolutely, or including the above cost differential, it was more profitable that if one stayed in farming he should raise citrus for as long as the projected tree decline rate would sustain a relative profit (Shoup, 1969).

Even the short-run intensification in lieu method was not widespread, particularly when air pollution damage, urban competition, land use incompatibility, and the lack of a good marketing arrangement problems were dealt with. Converting tree to row crops was, however, popular for some and by 1969 a small acreage remained. Walnuts, one of the Other Fruit and Nut Crops, declined early. It would seem feasible that intensive agriculture could be substituted for those walnuts geographically situated in the City of Industry where a zoning plan preserved land for long distant future use and protected agriculture against immediate encroachment, thereby assuring long-run planning. Nevertheless, walnuts were replaced by less intensive field crops, recognizing that although long-run planning could be exercised, the object was to sell land, not to earn agricultural income.² Clearing made land more appealing to the buyer and most smaller owners cleared opting to disinvest in this manner if it was necessary to enhance a sale. They could always lease it to grain farmers until urban uses eventually could succeed.

Field Crops varied little in value except for crops that required capital investment and/or maintenance, e.g. irrigated pasture and alfalfa, which had a higher and increasing return over time. Higher returns are likely as values are bid upward when supplies from the urban fringe

²Obviously, there are other reasons, e.g. tax advantages, which accrue to the large corporations holding this land.

TABLE 3
CROP VALUES AND YIELDS: RETURNS PER BEARING ACRE, EASTERN DISTRICT^a

Crop Type	Unit of Measurement	Nevins' Averages 1946-1950	1958			1960			DATE ^b 1965			1969			1970		
			(1)	(2)	(3) ^c	(1)	(2)	(3)	(1)	(2)	(3)	(1)	(2)	(3)	(1)	(2)	(3)
CITRUS FRUITS																	
Valencia oranges	Carton	\$445	150	\$ 3.50	\$ 526	282	\$ 2.18	\$ 612	295	\$ 2.55	\$ 780	225	\$ 0.75	\$ 170	300	\$ 1.90	\$ 570
Navel oranges	"	693	170	3.20	544	288	2.35	657	310	3.05	1,000	120	1.75	210	250	2.50	625
Lemons	"	782	438	1.60	700	483	1.56	750	468	2.47	1,100	375	2.75	1,030	450	1.50	675
OTHER FRUITS AND NUTS																	
Walnuts	cwt.	\$108	0.8	\$19.00	\$ 16	2.8	\$25.00	\$ 73	0.9	\$24.00	\$ 22	-	-	-	-	-	-
Peaches	20# Lugs	-	-	-	-	184	1.00	184	145	1.56	269	-	-	-	-	-	-
Avocados	13# Flats	358	200	1.80	360	250	1.21	298	100	3.25	325	218	\$ 3.00	\$ 300	200	\$ 4.95	\$ 990
FIELD CROPS																	
Alfalfa hay	Ton	\$145	5.75	\$26.00	\$ 150	5	\$32.00	\$ 160	10	\$27.40	\$ 280	40	\$ 6.50	\$ 260	48	\$ 8.00	\$ 384
Beets, sugar	Ton	-	4	10.00	40	-	-	-	-	-	-	-	-	-	-	-	-
Grain, Barley	cwt.	1	15	2.20	33	10	2.20	22	15	2.55	39	5	7.60	13	16	2.45	39
Grain, Hay	Ton	-	2.1	27.00	57	1	34.00	34	2	29.50	59	1.5	40.00	60	2	35.00	70
Grain, Wheat	cwt.	-	-	-	-	10	3.10	31	-	-	-	-	-	-	-	-	-
Irrig. Pasture	acre	-	-	-	125	-	-	160	-	-	170	-	-	200	-	-	200
Dry Beans	cwt.	164	11	10.50	113	13	11.40	148	12	10.00	120	-	-	-	-	-	-
VEGETABLE CROPS																	
Cabbage	80# Crates	\$387	325	\$ 1.70	\$ 554	300	\$ 1.75	\$ 525	390	\$ 2.72	\$ 1,070	200	\$ 1.75	\$ 350	275	\$ 2.25	\$ 620
Cauliflower	45# Crates	378	500	1.25	624	550	1.24	686	595	1.62	960	600	1.75	1,050	600	1.75	1,050
Chinese Food Veg.	Cartons	-	-	-	1,000	-	-	600	-	-	-	600	4.00	2,400	400	4.00	1,600
Tomatoes	-	621	-	-	-	-	-	-	-	-	-	-	-	-	-	-	-
Onions (dry)	50# Sacks	558	670	1.00	670	960	1.46	1,410	890	2.25	2,000	900	1.90	1,710	750	1.75	1,310
NURSERY STOCK & CUT FLOWERS																	
Cut Flowers	-	-	-	-	\$ 936	-	-	\$ 1,070	-	-	\$ 1,000	-	-	\$ 8,120	-	-	\$ 7,800
Nursery Stock	-	-	-	-	12,500	-	-	15,000	-	-	13,000	-	-	18,000	-	-	17,100

Sources: Nevins, J.A. "The Puente Area: A Study of Changing Agricultural Land Use," unpublished M.A. Thesis, Department of Geography, University of California, Los Angeles, 1951. ^aAnnual Plant Crop Report for the Eastern Area, Los Angeles County, Agricultural Commissioner.

Notes: ^bData for 1953 are unavailable. 1959 data are questionable owing to serious crop losses in that year. Figures exclude USDA payments.
^c(1) Yield in units of measurement per acre; (2) Value per unit of measurement; and (3) Value per acre harvested.

progressively become less as these lands are converted in use. Yet, their ability to economically compete with urban land use remains poor.

Small acreages of Vegetable Crops in the transition zone are not extensive because they are selective as to site - soil and climate - considerations. More, they are selective to a particular economic situation - the availability of a properly skilled farmer and a favorable leasing arrangement. These farms are not important producers but are means to offset carrying costs of land taxed at urban rates and, as a result, are operated for two different reasons: the landowner wants a rent to pay high taxes; the tenant-operator farms for short-run profit only. The tenant cannot make major investments because the long-run future is in doubt. He maximizes returns insofar as he is able to manipulate the factors of production available to him and his yields and returns fluctuate accordingly. Available farm land is restricted to where he finds a sufficiently long-term leasing arrangement.

High value, labor-intensive "urbanized" agriculture such as Cut Flowers and Nursery Crops do not expand simply because returns are high but respond to many factors. Being highly market-oriented, similar to a commercial enterprise with a threshold size and marketing area, their services in suburbs have a particularly high demand. Increasing returns stimulated expansions until 1965, many producers being so marginal that net values fell. Acreage declined from 1965-68 and the industry appeared to have readjusted by 1969-70. Acreage increased slightly over 1960, and productivity, markedly, to a high never before reached.

Yield Trends

Citrus Crop yields and value data were available only for the years indicated (Table 2). Nevertheless, they show important changes between the 1960 and 1967-68 periods. Yields fell in 1968, but high market prices counteracted per acre losses. Supply and demand made adjustments between 1960-68, i.e. acreage was halved 1960-65, but yields increased, particularly for Valencia oranges. Severe losses in 1968 due to environmental conditions speeded the decline of citrus because in 1970 only a partial recovery is indicated.

Other Fruit and Nut Crops are somewhat unique and flourish only under special circumstances. Walnuts declined in the 1960's so far that by 1967 they reached the nadir in both value per unit of production (\$3.00 per cwt.) and yield per acre (140 lbs., or \$4.20 per acre). Avocados varied in yield; corresponding value per unit fluctuated in a manner reflecting that supply and demand operated.

Dry-farmed Field Crops, of course, vary in yield as water is available. Barley acreage produced both a hay and a grain that were valued, and a combined \$70-90 per acre yield was realized in most years besides the value of grazing stubble fields (approximate value is \$2-3 per acre).

Prices varied but remained somewhat uniform for Vegetable Crops in this same period and, as yields were improved, it seems unlikely that acreage would decline. Perhaps the mixed purposes involved in row cropping accounts for the unexpected response. Cabbage declined in acreage as its yield and unit value of product declined. Reduced dry onion and cauliflower acreage, however, is not supported similarly. Chinese Food vegetables are an exception. Their increase may be attributed to improved yields and returns per acre, although the data are too limited to establish any trend.

WALNUT VALLEY LAND USE: AGRICULTURE (ANIMAL CROPS)

Livestock and poultry inventory and production figures also reveal the inroads of urbanization in Los Angeles County, first in a trend toward intensification of production and more recently in the dispersal of producers into adjacent, lower producing cost areas with legal protection for agricultural land use. Countywide statistics show the important dairy industry (approximately two-thirds the total value of animal production) and poultry (averaging 25-40 percent of the total value) are relocating and this steadily lowers the total figure (Los Angeles County, Agricultural Commission, 1938-1970). From a historic value peak of \$153.9 million in 1953, County animal production figures decline to where they stood at \$62.7 million in 1970. Gregor (1963) observed intensification of animal cropping accompanying the decline of cultivated acreage, and also observed the beginning of a spread into adjacent counties. He could not foresee the accelerated rate since then. Gregor describes these trends as a spread of intensive agriculture ahead of the urban fringe. A void develops economically which Nursery Stock and Cut

Flower production (now the nation's highest County production, \$41.7 million in 1970 produced from a mere 2,627 acres) was able to fill. The reduction of transportation costs and increasing population and purchasing power assures that some intensive agriculture can remain in a belt surrounding the city. Low transportation costs, however, brought other areas with similar advantages into consideration, and dairies and poultry farms, more objectionable than nurseries and less able to produce high values per acre, were attracted to western San Bernardino and southern Kern counties. With the dissolution of protective agricultural zoning in Los Angeles County and with the creation of the same in adjacent counties, the industry has successfully made the transition to producing from a more distant site (Fielding, 1964).

Livestock censuses of the Los Angeles County Livestock Department are the only data for subcounty areas. Walnut Valley animal crops cannot be separated from the gross data and studied in detail, hence the explanation of general trends. The area boundaries used differ from those the Agricultural Commissioner uses and enclose larger areas, four being sufficient to delineate major regions:

- 1) the Antelope Valley of the County's desert fringe, the largest area;
- 2) the San Fernando Valley; and,
- 3) the San Gabriel Valley which have comparable urbanization and prior land use histories; and,
- 4) the Southern area or the Los Angeles Basin. It is also topographically defined except in the southeast where the San Gabriel Valley area extends beyond relief features to include parts of the county with similar animal production; the Southern area then becomes almost exclusively a dairying region.

Intensive animal crop agriculture also shows a declining animal population over the study period. Dairy cattle numbers are 40 percent of their peak in 1954 (143,182 versus 53,400 in 1970), and beef cattle (largely on feed lots) are reduced to one-third (77,400 in 1956 to 32,200 in 1970). Poultry numbers fell similarly (9,491,000 in 1955 to 3,286,000 in 1970). Los Angeles County increasingly has been forced to draw upon the production of other areas as population grows and no longer can be considered self-sufficient in the basic animal crops. In specialized horticultural crops, it remains a net exporter of goods. The transplantation of market-oriented activities, beginning over a decade ago, has clearly increased but has remained an intraregional shift.

Overall production in southern California reflects a general intensification of the already intensive, high-cost irrigated agriculture despite localized losses and regressions on the Los Angeles metropolitan fringe.

Walnut Valley animal crop production is reflected in a minor trend toward the shifting of production within the county. As all production declines, feed lot operations (16.2 percent of the total value) tend to resist urbanization and stay the outflow to cheaper producing areas. The San Gabriel Valley has localized advantages and accomplished this best. In the last decade, it has averaged 15-16,000 animals in pens. In 1970, the number stood at 17,900 animals or 29.8 percent of the County total. Centralized locations with higher land costs, (the Southern area) have higher feed costs now that local plant crop production has dissolved. Peripheral areas, particularly the San Gabriel Valley area which draws on Walnut, the Coachella and the Imperial Valleys of Los Angeles, Riverside, and Imperial Counties, and to a degree the Antelope and San Fernando Valleys which also have access to forage, remain viable beef cattle feeding areas.

WALNUT VALLEY LAND USE: INDUSTRY

Suburban sprawl competed with industry to occupy the Valley after World War II. Industry, however was promoted, was emphasized, and then provided for in the incorporation of the City of Industry, the preservation of suitable land, and in the provision of freeway access. Industry was the impetus to regional growth. Residential expansion came after the fact of assuring that the region would open for which industry was the lever.

Industrial growth accelerated rapidly in the late 1950's and mid 1960's. In 1958, there were only 41 firms with an employment of 2,858 persons, but by 1960, the numbers increased to 70 firms and 3,688 employees (City of Industry, 1971). By 1965, the number stood at 196 firms and 11,760 employed; in 1969, it was 271 and 25,800, respectively. While growth has filled up much of its area, the City of Industry remains the largest industrial land reserve south of the San Gabriel Mountains (over 4,000 acres is involved here, nearly 1/5 the vacant, potentially industrial, land reserve in the Basin) (RPC, 1968).

Sixteen Standard Industrial Classifications (SIC) are represented in the City of Industry, the largest of which is electrical machinery (SIC 36), with 18.9 percent of the industrial labor force (City of Industry, 1971).

Transportation equipment (11.7 percent) and Fabricated Metals (9.8 percent) are the next largest classifications. The City of Industry draws on a civilian population of 450,000 in the Eastern San Gabriel Valley from which 139,000 enter the labor force. Hence, the laborshed is more extensive and older than the residential development in Walnut Valley; industrial growth, however, was not the only factor stimulating residential growth in the San Gabriel Valley nor in the Walnut Valley.

WALNUT VALLEY LAND USE: RESIDENTIAL

Residential growth since 1953 has accompanied industrial development in regular increases of about six to eight acres for every acre of industrial use added (Table 1). Many of the same factors that influence construction, i.e. financing and the general economic condition, apply in both instances. Regional population growth and local demands for land in the San Gabriel Valley have, of course, provided primary incentives.

Population Growth and Land Demand

Since 1950, Los Angeles County aggregates population and housing data on the basis of statistical areas. These are designed to encompass geographic regions as nearly as possible and to conform to political boundaries and census tracts. Statistical Area 26.0 (Puente Hills, the study area) had 6,395 persons in 1930, but grew rapidly after the War to 97,796 persons in 1960, slackening its growth rate only recently (Figure 1). La Puente was the first city to incorporate in the Valley (1956), the City of Industry was second (1957), followed by Walnut (1959). Four "communities" may incorporate as growth proceeds (Hacienda, Rowland, and La Habra Heights, once important citrus producers, and Diamond Bar, a former ranch, all Map 2). Following the 1960 census, substatistical areas were formed to recognize this growth.

Projected population for the County and S.A. 26.0 indicated in 1965 that both would increase at the 1960-65 rate until 1970, whereupon County growth would continue similarly to 1985 and S.A. 26.0 growth would accelerate. S.A. 26.0 will assume then a greater share of County growth as its relative isolation is diminished with the Pomona Freeway complete to Diamond Bar in 1970, and with another freeway, the Orange Freeway approaching from the south, connected to it by the mid-1970's. Growth continues as expected, but at a rate reflecting the national housing market since the mid-1960's.

FIGURE 1
POPULATION GROWTH:
PUENTE HILLS STATISTICAL AREA

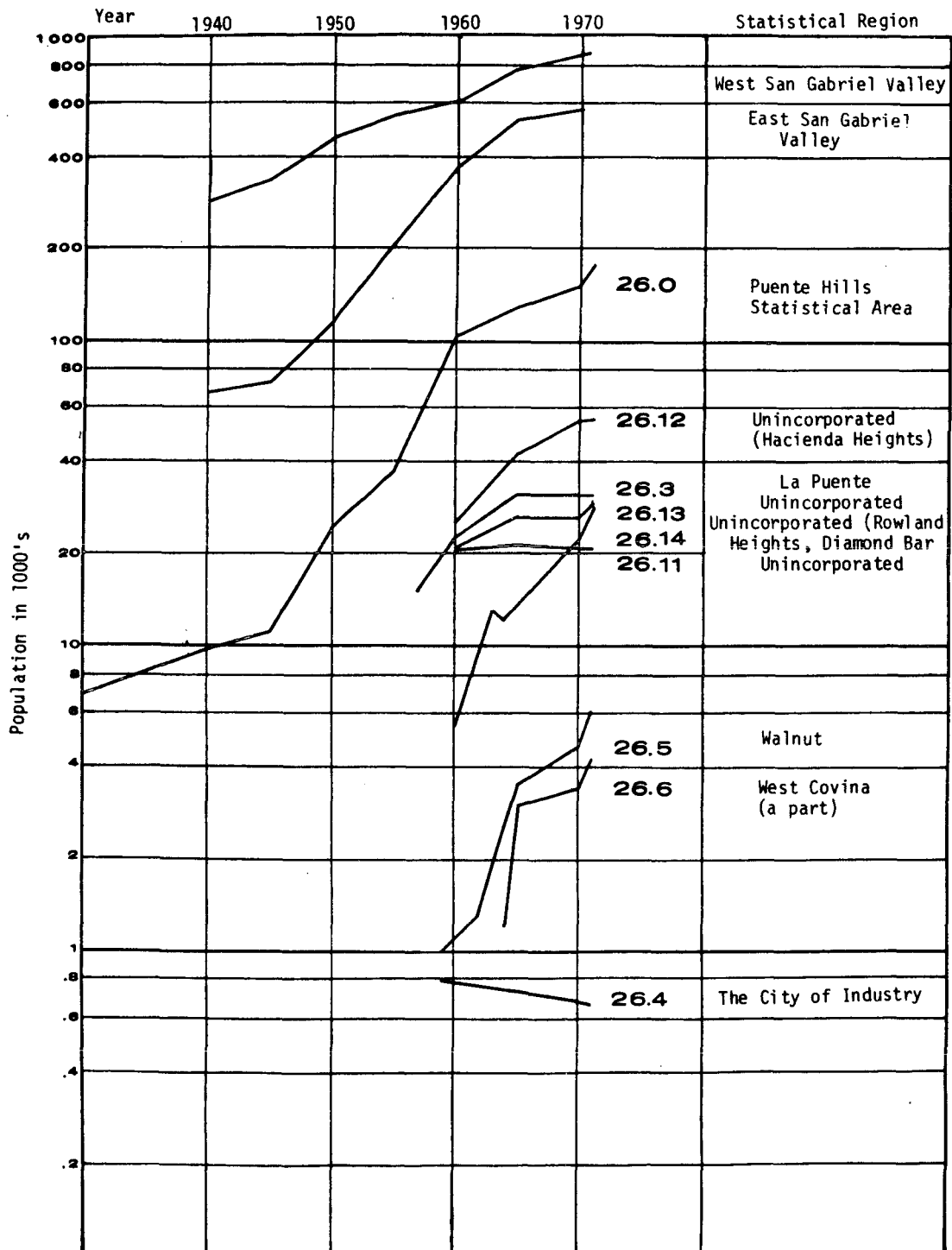

Note: The West and East San Gabriel Valleys each are groups of Statistical Areas. The staggered convergence of growth rates indicates the order at which these areas and the Puente Hills Statistical Area became accessible, first by the San Bernardino Freeway and then by the Pomona Freeway.

Source: Los Angeles County, Regional Planning Commission, Population Research Section.

Map 2

DIVISIONS OF THE PUENTE HILLS STATISTICAL AREA (26.0)

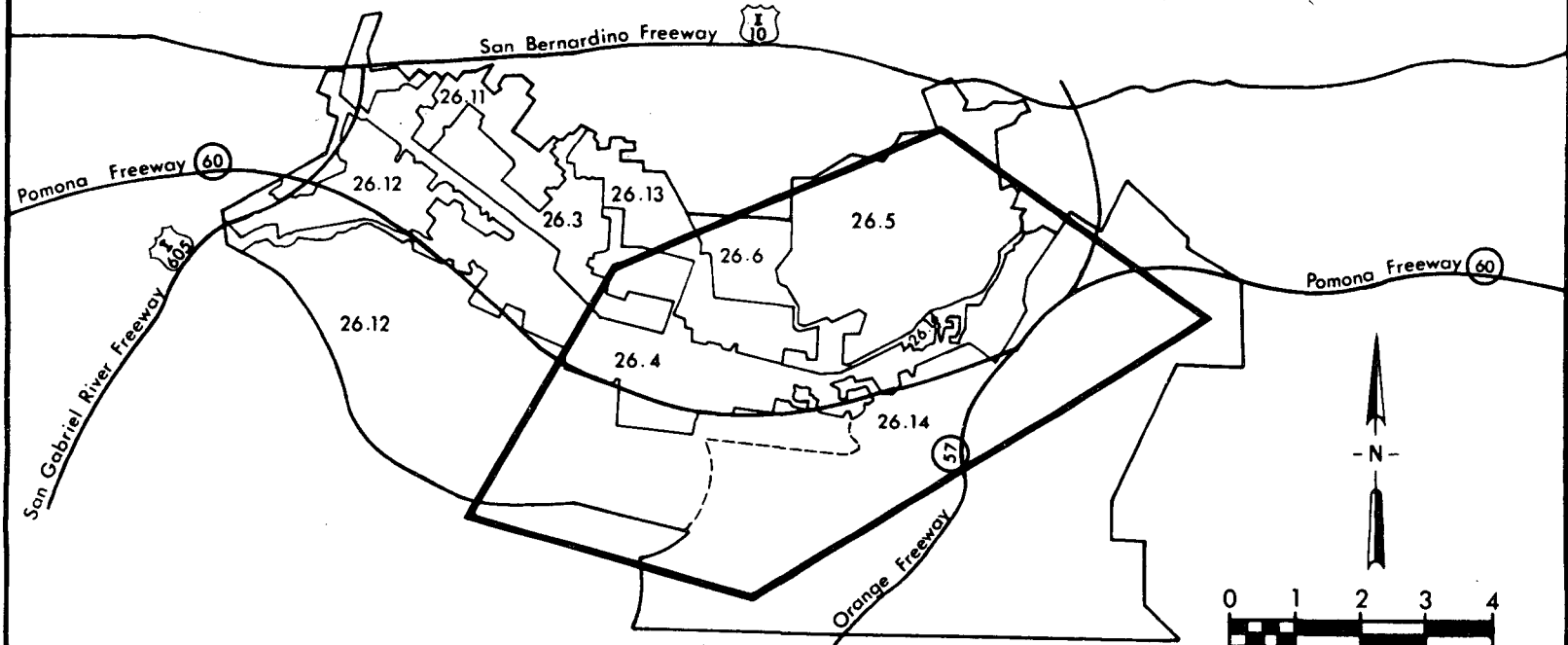

Legend

Linear Features

- Boundary, sub-statistical areas
- Boundary, Puente Hills Statistical Area
- Freeway system
- Boundary, Walnut Valley Study Area

Sub-Statistical Areas

- | | |
|---------------------------|---|
| 26.3 La Puente | 26.12 Unincorporated (Hacienda and part of La Habra Hts.) |
| 26.4 The City of Industry | 26.13 Unincorporated |
| 26.5 Walnut | 26.14 Unincorporated (Rowland Heights and Diamond Bar) |
| 26.6 West Covina (a part) | |
| 26.11 Unincorporated | |

Source: Los Angeles County, Regional Planning Commission, Population Research Section.

Substatistical areas differ widely in rates of growth; some grew uninhibitedly, e.g. the 26.12 (Rowland Heights), 26.14 (Diamond Bar), and 26.5 (Walnut) areas where most of the remaining vacant land remains. Others, the heavily populated 26.3 (La Puente) and adjacent 26.11 and 26.13, have slackening growth rates. Industry has lost population with incorporation; what remains is a small, elderly population some of which are retired farmers. Zoning prohibits these homes from increasing, being expanded, or improved, and as long as taxes are relatively low, some housing will remain until deterioration becomes severe.

Rates of Subdivision

Subdivisions recorded in S.A. 26.0 (Table 4), reflect not only economic trends and their effect on the building industry, but point to the character of Walnut Valley's cities, their reason for existence, and the direction toward which development has moved. La Puente on the west developed in the 1940-50 decades and is highly developed today. West Covina has extended its boundaries from the San Gabriel Valley proper across the San Jose Hills to annex vacant territory for its future growth. Walnut grew only after incorporation, and the City of Industry's subdivisions were for industrial purposes. Unincorporated territory is more extensive than the others added. It is divided into several identifiable "communities" not yet of incorporated status, owing to the history of development which emphasized pockets and valleys within the main hill masses. In the unincorporated areas, scatteration is the rule. With the main valley, Walnut Valley, preempted by the City of Industry, residential development could spread only into peripheral areas and use opportunities in order of their ease of development - lands that were accessible in terms of terrain or available in terms of the stage of agricultural decline. The Hacienda and Rowland Heights pockets began to develop in 1955 and 1958, respectively; the level portions of Brea Canyon in 1960. By 1963, rolling terrain on the west, in Hacienda Heights, was subdivided, and in the mid-1960's rolling terrain in the east was also developed.

Residential development can be divided into three historical periods each of which is locationally correlated. Given that development in the valley proper is excluded, the first subdivisions were on land easy to develop in pockets and small subsidiary valleys (cheap land with low development costs). The second wave emphasized more difficult-to-develop terrain

TABLE 4
SUBDIVISIONS RECORDED - LOTS PLATTED: PUENTE HILLS STATISTICAL AREA

DATE	LA PUENTE		WALNUT		INDUSTRY		UNINCORPORATED		TOTALS	
	a	b	a	b	a	b	a	b	a	b
1950	0	0	0	0	0	0	18	1,555	18	1,555
1951	0	0	0	0	0	0	9	502	9	502
1952	0	0	0	0	0	0	6	315	6	315
1953	0	0	0	0	0	0	27	1,822	27	1,822
1954	0	0	0	0	0	0	40	3,458	40	3,458
1955	0	0	0	0	0	0	52	5,793	52	5,793
1956	0	0	0	0	0	0	16	1,248	16	1,248
1957	1	62	0	0	0	0	19	1,178	20	1,240
1958	1	41	0	0	0	0	15	1,251	16	1,300
1959	2	71	0	0	0	0	24	1,425	26	1,496
1960	1	20	0	0	0	0	35	2,358	36	2,372
1961	2	50	1	87	2	105	36	2,006	41	2,248
1962	6	227	2	195	0	0	56	3,122	64	3,544
1963	2	119	3	220	0	0	45	2,997	50	3,336
1964	0	0	9	412	0	0	41	2,169	50	2,581
1965	1	8	2	171	0	0	24	1,423	27	1,602
1966	0	0	2	36	0	0	18	338	20	374
1967	0	0	0	0	2	23	17	994	19	1,017
1968	0	0	0	0	3	33	16	721	19	754
1969	0	0	2	92	0	0	20	1,263	22	1,385
1970	0	0	0	0	0	0	12	612	12	612
TOTALS	16	598	21	1,213	7	161	543	36,550	587	38,522

Source: Los Angeles County, Department of the County Engineer, and Security Pacific National Bank, Economic Research Department.

Notes: (a) Number of subdivisions; (b) Number of lots platted. In the period covered by this study, 37,160 dwelling units were added to the total housing inventory. Prior to 1953, there were only 7,137 units. The main emphasis on housing construction has obviously been in the post-freeway period.

(cheap land with high development costs). The third wave (the present) not only fills in gaps of the previous cycles but stresses high density development on commercial or multiple family-zoned land (expensive land with low development cost). These waves generally parallel the freeway planning, construction, and completion stages.

Zoning is correlated with development age and terrain, and city character and objectives are also revealed in the types of zones. Lot size and zoning permissiveness varies in residential zones (Los Angeles County, 1927). Agricultural zoning is widespread, even in areas with an urban use because the zoning permits parcel size minima to be reduced to allow tract housing and the production of crops. Residential Agriculture (RA) zones work similarly, but here the property owner may keep horses because lot size minima are sufficiently large as to provide the necessary segregation of man and beast that health regulations require. These zoning types are common in parts of Los Angeles County where development is young, where sales appeal is often based on perceptions of "rural properties with urban conveniences." Traditional residential zoning (R-1) is found in the older (pre-1955) areas.

La Puente is an extension of the urban fringe in the pre-freeway period and a fairly densely populated city more in common with older parts of the metropolitan complex. Development of the unincorporated areas involved the use of agricultural zoning (A-1-6000) on level terrain, and residential agriculture (RA with lot size minima) on hilly terrain where large lots and horse ownership are feasible. RA zoning appeared later in the development history and is more important today as development has "gone to the hills."

WALNUT VALLEY LAND USE: LAND VALUES

Sample parcels were selected, at each end of the valley, on different types of terrain, and at different locations with respect to the freeway, for assessed value appreciation over the term of this study. Data are available from the Los Angeles County Assessor for only 12 years and since few parcels remained intact but were subdivided and reshaped in that period the selection was much restricted.

Land values appreciated 400 percent in eight years for the examples of unimproved industrially zoned land (Table 5 and Map 3, see examples 1-5,

TABLE 5
 EXAMPLES OF LAND VALUE APPRECIATION
 (See Map 3)

<u>Example</u>	<u>Date</u>	<u>Assessment Land</u>	<u>Assessment Improvements</u>	<u>Parcel Size</u>	<u>Assessed Val/Acre</u>
1	1970	\$130,000	\$ 510	26.0+ acres	\$5,000
	1965	65,000	3,170		2,500
	1962	32,000	3,170		1,250
2	1970	570,000	250	142.36+ acres	4,000
	1965	355,000	1,050		2,500
	1962	175,000	1,050		1,300
3	1970	33,750		9.11+ acres	3,700
	1965	27,250	2,170		3,000
	1962	7,300	2,170		800
4a	1970	84,250		102.04+ acres	8,250
	1967	88,750			8,700
	1965	80,500			7,900
	1962	80,000			7,900
4b	1970	450,000		372.07+ acres	1,200
	1967	379,000			1,020
	1965	372,500			1,000
	1962	75,000			200
5a	1970	28,750		5.00+ acres	5,900
	1965	12,500			2,600
	1960	7,400			1,500
5b	1970	25,625		5.00+ acres	5,300
	1965	13,500			2,800
	1960	7,000			1,450
5c	1970	24,000		5.00+ acres	4,900
	1965	12,000			2,500
	1960	7,000			1,450
6a	1970	26,250		7.92+ acres	3,300
	1965	18,000			2,300
	1962	11,000			1,400
6b	1970	50,000		11.14+ acres	4,500
	1965	27,500			2,500
	1962	13,500			1,200
6c	1970	26,500		5.87+ acres	4,500
	1965	18,500			3,150
	1962	10,500			1,800

Source: Los Angeles County Assessor

Note: Los Angeles County assesses property at approximately one fourth the market value.

Map 3: Zoning

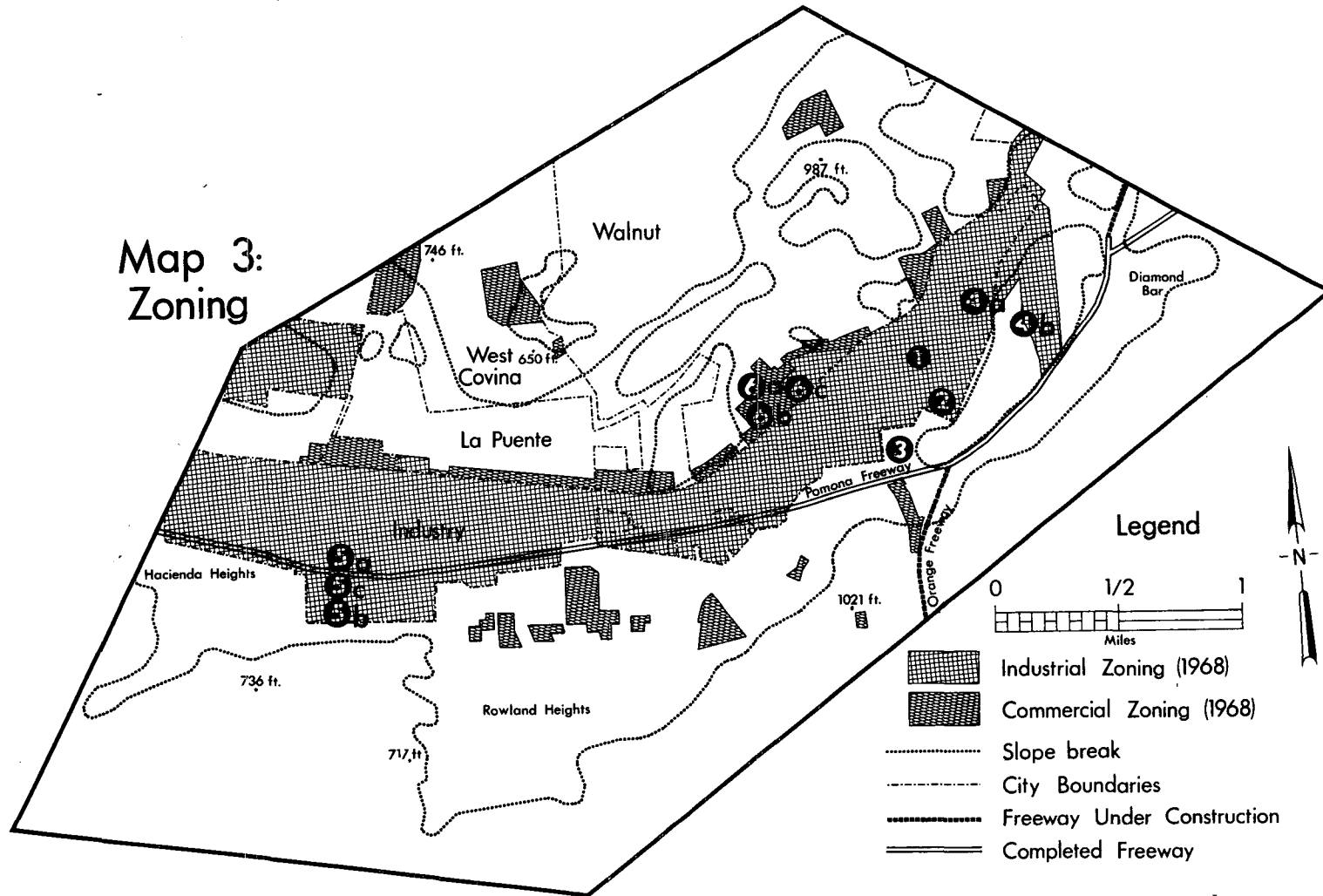

excluding 4b). More than a doubling has been the norm for residential property in the same length of time (see examples 6 and 4b). It would be assumed that the rate would be greater if data were available for earlier periods.

Examples 1-3 changed in use from long-established citrus and small groves of walnuts to field crops in 1969 (see improvement value), a measure that certainly enhanced development potential that became possible with the decline of these groves. Two hill parcels, examples 4a and 4b, appreciated considerably but at different rates. One is zoned for industry, parcel 4a, and is more level than rolling in general profile; parcel 4b is residentially zoned (A-1-15,000) and is quite hilly.

Freeway-accessible property appreciated in a manner that suggests its key location. One 300 acre parcel was divided into 5± acre parcels, some of which abutted the freeway (Table 5, 5a), and others, a major highway (Table 5, 5b). Once the freeway was complete, the peak values shifted from frontage property on the surface road to property on the freeway. Roads of greater capacity influenced land values more.

Off the main axis of Walnut Valley, in terrain pockets and valleys destined for residential use, land values rose but by not as large a margin, and the values per acre are not as great. There was uniformity among unit values except where some amenity was influential such as frontages, example 6b and c.

The above examples and others studied are scarcely adequate to explain the factors in land value. A more intense study is necessary to unravel the manner in which land values changed over time in this specific case. Nevertheless, some generalizations seem valid:

- 1) Land valuation trebled in eight years for most parcels, and if data were available, greater rates of change are likely to be shown dating to the pre-freeway period, e.g. the entire parcel, example 5, valued at \$900,000 in 1954, was revalued at \$12 million in 1968.
- 2) Undeveloped industrial property is worth more than residential property by a factor of two.

Major influences on land value - accessibility, population growth, and legal restrictions such as zoning - enhance the development of certain areas. Land use intensity closely relates to land value as each landowner

establishes a long-run land use plan that optimizes returns from the land, economic or other (non-economic) return. His momentary plan is revealed in tangible land use, and the dynamics of his decision-making is revealed as one of five rural-urban conversion processes - an intensification, a direct conversion, a succession, a disinvestment in lieu or a simple disinvestment land use decision. His long-run plan considers the timing of the eventual conversion, the approaching development frontier. This varies among property owners as they have information and an opportunity to make decisions.

CHAPTER III

RURAL-URBAN LAND USE CONVERSION: A DOCUMENTARY

Property owner decisions to intensity, disinvest, or to let urban uses succeed are immediately observed and recorded by the periodic remote sensing of developing areas. Information is more readily available to planning agencies than by their current methods - tedious map plotting of current zoning activities and an analysis of the trends after the fact of development (if such advance planning can be said to exist, for example see Bowden and Goehring, 1970). Subtle changes within the near-vacant or agricultural land use patterns on the fringe can give indications of the direction, rate, and character of impending urban development. Data can be complete, and updating is facilitated by noting only the changes taken place. Policies with regard to zoning, subdivision control, capital programming, comprehensive planning and land acquisition may be administered as areas ripen for development.

Aerial photography, cited earlier, was interpreted according to a twenty-place identification key and the results were plotted on overlays superimposed on a topographic base.¹ Land use tended to conform with cultural

¹Some definition of the categories is appropriate at this time. Qualitative differences, e.g. good citrus (GC), citrus (C), poor citrus (PC), citrus abandoned (CA), Table 6, are applied to tree crops and are photographically illustrated in Appendix A. Extensiveness of the tree crowns, their uniformity, and their color (tone) were bases for the recognition. Walnuts (W) did not permit a "good" category to be determined as they are a deciduous crop which could not be observed well in the winter-spring of the year when most of the imagery was acquired. Since walnuts were on the decline already in 1953, the average and the easily-recognized poor (PW) and abandoned (WA) conditions (a factor explaining why urban fringes are considered unaesthetic; note the increase in the 1960's in Table 6), are more likely to be represented.

Mown grasses (MG) as interpreted from aerial photographs were sufficiently extensive as to require a special category which refers to areas where natural grasses and volunteer grains were cut for hay. Should these areas have been shown on subsequent photographs to be continuously sown in small grains, the original classification was changed.

Urbanized agriculture (UA) is defined as intensive, market-oriented agriculture such as dairies, nurseries and commercial flower raising, feed lots, and poultry farms which compete with urban uses on the value per acre basis and are intermixed with them, particularly on the urban fringe. Urban vacant (UV) is a classification to note improved, graded or leveled property upon which urban uses seem imminent.

These classifications are employed in the introductory table (Table 6), in the six maps of land use change (Maps 4-9), and in the tables which

TABLE 6
 PERIODIC LAND USE
 (in acres)

Source: Aerial Photo Interpretation.

Land Use Type	Key to Maps/ Tables	Date of Survey					
		1953	1958	1960	1965	1969	1971
AGRICULTURE							
Citrus							
good	GC	868	507	342	143	137	137
fair	C	1,314	1,154	831	297	102	102
poor	PC	91	50	154	348	231	231
abandoned	CA	24	29	113	137	140	140
Walnuts							
fair	W	1,207	554	280	69	36	36
poor	PW	134	304	443	321	257	251
abandoned	WA	40	80	46	98	72	62
Avocados	A	13	13	13	13	13	13
Field Crops	FC	3,020	3,393	3,334	2,988	2,753	2,542
Row Crops	RC	285	340	325	170	178	178
Mown Grasses	MG	3,157	2,991	2,879	2,147	2,127	2,092
Grazing	GR	3,200	3,018	2,915	2,795	2,762	2,760
TOTAL AGRICULTURE		13,353	12,439	11,675	9,511	8,808	8,544
URBAN							
Residential	UR	228	821	1,726	3,554	4,016	4,417
Industrial	UI	66	215	324	523	740	755
Commercial	UC	6	9	9	56	84	154
Recreational	URe	0	0	39	341	363	363
Institutional	UIIn	156	156	166	279	373	373
Agricultural	UA	230	277	267	287	264	264
Vacant	UV	321	517	361	406	456	502
TOTAL URBAN		1,007	1,999	2,892	5,446	6,294	6,828
VACANT		22,663	22,595	22,456	22,056	21,919	21,651
TOTAL LAND USE		37,023	37,023	37,023	37,023	37,023	37,023

features - boundaries and the transportation grid - and the United States Geological Survey base for control permitted each overlay (one for each period) to be compared with previous analyses through superimposition. Each overlay represents a separate map of change and a reflection on the growth character of the past year or years. A series of such overlays shows urbanization pressures as successive manipulations of land use that intensify or disinvest in agricultural land uses, or succeed to urban uses. Transparent photographic imagery with controlled photo mapping performs this task even better. Images from succeeding years can be superimposed, changes noted, and, if an initial land use map was compiled, these amendments would produce an up-to-date land use table and map.² The ease with which current data can be provided destroys one of the more common arguments against using land use change in studies of dynamic urban morphology: the tediousness of land use surveys done by field methods.

Each time period is discussed individually and no projections were made in time to space the survey better given the irregular photo coverage. For example, the first period, 1953-58, represents five years of change; the second period, two. Since economic conditions greatly influence conversion processes, regular surveys could better date the time span in which change began and provide a focus on the kind of response by decision-makers to those conditions. Otherwise, five years must of necessity be assumed to

accompany the last five maps (Tables 7-11). No good purpose would have been accomplished if individual crops were recognized, whereas in similar reports for other areas, where the latitude for agricultural land use change is wider, additional detail not only is feasible but would be extremely useful.

²The materials-balance or input-output table approach is extremely useful in noting the type of land use committed to and output from the change. The results can be highly accurate if one establishes strict controls in the mapping process. For example, the method requires remeasuring a parcel or part of a parcel when it is changed in use. Ownership lines may change and distort previous boundaries so that the parts, when reassembled, may not add up to the whole, and this invariably has happened in the report.

A greater problem has risen because of an initial decision to delete the category "transportation" from the land use table as this would require measuring local streets as well as the freeway. A freeway of this size (8 lanes) absorbs 30-45 acres per mile of right-of-way and 40 acres at interchanges alone, and with additional street widenings and new streets added to the transportation grid as the area developed, the output phase of the tables increasingly contain a measure of error.

have evolved as one trend, and correlations with crop and other data (Chapter II) are similarly placed on a less sound comparative basis.

LAND USE IN 1953

Land use in 1953 (Map 4) closely corresponds to terrain, as stated above (Chapter I), and to distance from the metropolis. Intensive agriculture-citrus - is concentrated more in the eastern half of the study area; walnuts lie in the center of the valley; field crops are more important in the west end. Row crops, principally smog susceptible varieties, are farmed on the extreme eastern edge of the study area in Diamond Bar, a minor valley, where they are less liable to air pollution damage. Sixty percent of the study area was vacant and essentially untouched excepting whatever grazing a dense oak-native black walnut woodland and chaparral affords. Grazed or pastured acreage, field crops and mown grasses, were approximately equally extensive and, when added, were two-thirds of the agricultural acreage (9,377 acres). Most of the remaining land use was devoted to arboreal culture (3,678 acres). Urban uses, aside from recently cleared and graded land (321 acres), one large institution (junior college), and intensified or "urbanized" agriculture (dairies and feed lots), added to only 300 acres.











Citrus appears to have been an important crop in this period. High quality acreage is extensive (868 acres), and poor (91 acres) and abandoned acreage (24 acres) was minimal. Rowland Heights, soon to be subdivided, contained the largest acreage of the crop, particularly the good quality citrus. While walnuts were widely scattered, the valley floor was emphasized by containing the bulk of the large acreage (1,207 acres). Poor walnuts were only 12 percent of the total; the low quality category, however, appearing in the westerly half of the study area, suggests disinvestment there as a possible prelude to the urban fringe, only several miles westward. Nevins' work (1951) in the La Puente area indicates that while rural-urban conversion had begun there, farther east in the Walnut Valley land uses remained relatively intact. Certainly there were premonitions of change by 1953, however.

Walnut Valley was essentially rural in 1953 but had manifestations of rural-urban fringe activities - land use intensification, disinvestment, and cases of urban succession or completed conversion cycles were evident. Urban agriculture consisted of three dairies which were attracted to the region,



Land Use/Land Use Change Legend for Maps 4-9

Abbreviations for Tables 6-11.







Agricultural Patterns

 Avocados (A)	 Vacant
Citrus	 Grazing (Gr)
 Good (GC)	 Mown Grasses (MG)
 Average (C)	 Field Crops (FC)
 Poor (PC)	 Row Crops (RC)
 Abandoned (CA)	

Walnuts

 Average (W)
 Poor (PW)
 Abandoned (WA)

Urban Patterns

 Residential (UR)	 Recreational (UR)
 Industrial (UI)	 Agriculture (UA)
 Commercial (UC)	 Vacant (UV)
 Institutional (UIn)	

Line Patterns

 Freeway Under Construction	 Completed Freeway
--	--

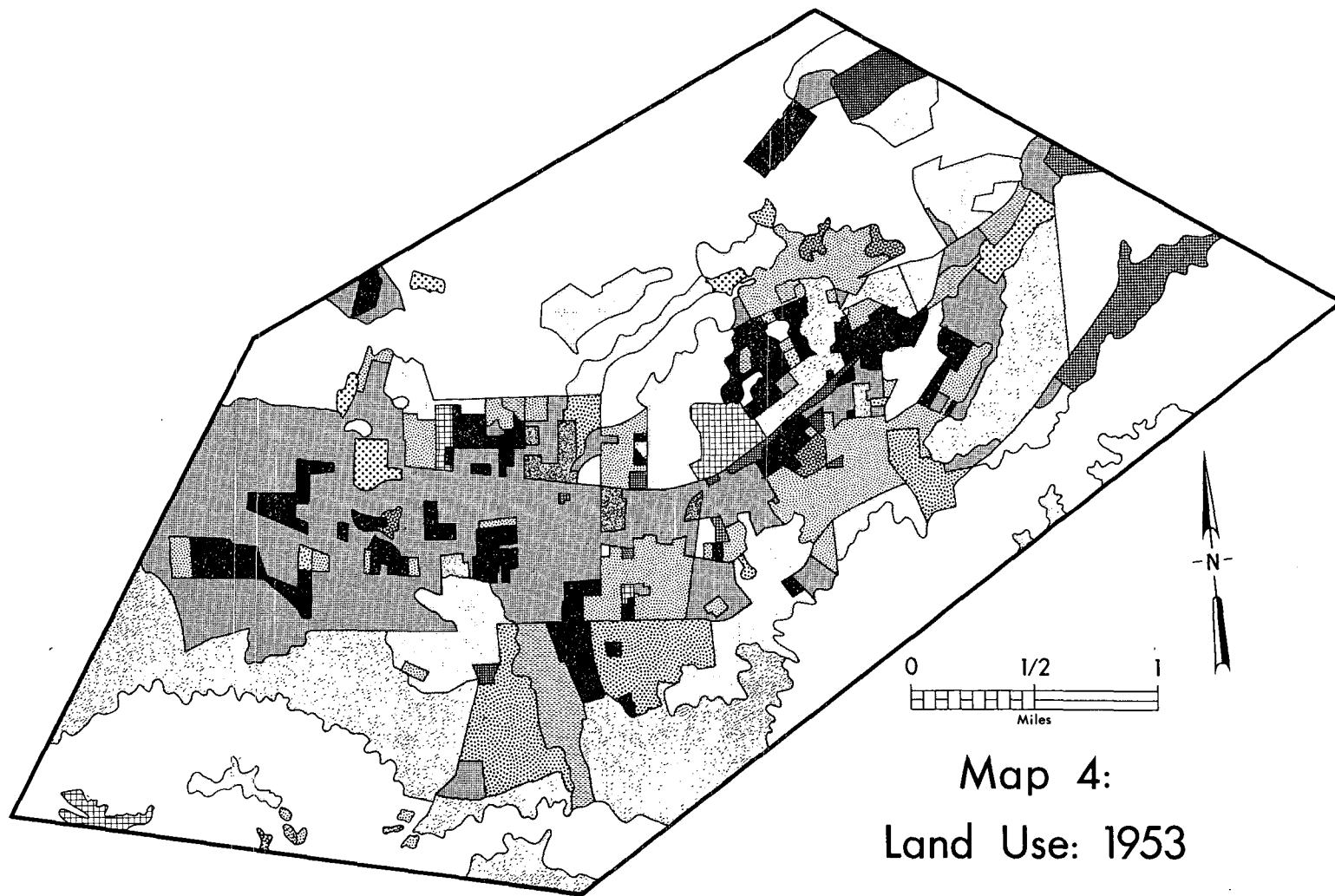

Map 4:
Land Use: 1953

rather than to the then-intensely developed milkshed south of the metropolitan core (Fielding, 1962), because of the availability of locally produced forage and ease of acquiring more distant supplies by rail. Producers located near the present urban fringe, in the area soon to incorporate as the city of La Puente. On the opposite (eastern) edge of the study area, feed lots, emphasizing similar forage sources as the dairies, developed where the rights-of-way of both rail lines converge at a constriction of the valley.

Urban developments are quite old, and there is reason to doubt that recent urban influences permeated more than just the areas on the immediate fringe. The large residential area in Walnut dates to 1921. Other examples were built in the 1920-30 southern California subdivision boom; one is specialized - a retirement center. These earliest developments were largely independent of metropolitan influences and, as their age indicates, were far beyond the fringe as isolated nuclei. These were not "suburbs in search of a city," contrary to southern California tradition, but were centers that lacked sufficient gravity to attract further growth. Now old, they are the Valley's poorest housing and a distinct contrast with the recent development that surrounds them (Plates 1 and 2).³

Earlier imagery (1939 United States Department of Agriculture, Soil Conservation Service photography which was unavailable) would have reflected on a more important agricultural period, long before urban uses were considered and development potential reappraised. Antecedents to 1953 patterns would better define a starting point for establishing trends in urban fringe evolution. By 1958 drastic changes in political and economic factors (Chapter I) became significant. The great thrust to urbanize Walnut Valley is evidenced in the development of the conversion cycle, in land use, the kinds of land use input to the conversion processes, and in the rate of land use conversion.

LAND USE IN 1958: CHANGES SINCE 1953

Since 1953, the Pomona Freeway plans had been disclosed and two cities had incorporated. Land use conversion to urban uses began in earnest and was completed for 789 acres of agricultural land use and 67 acres of urban vacant property (all land use types are adjusted in the 1958 land use to conform to the changes, Table 7). Urban uses first appear in the western

³Plates used to illustrate the text are assembled in Appendix B.

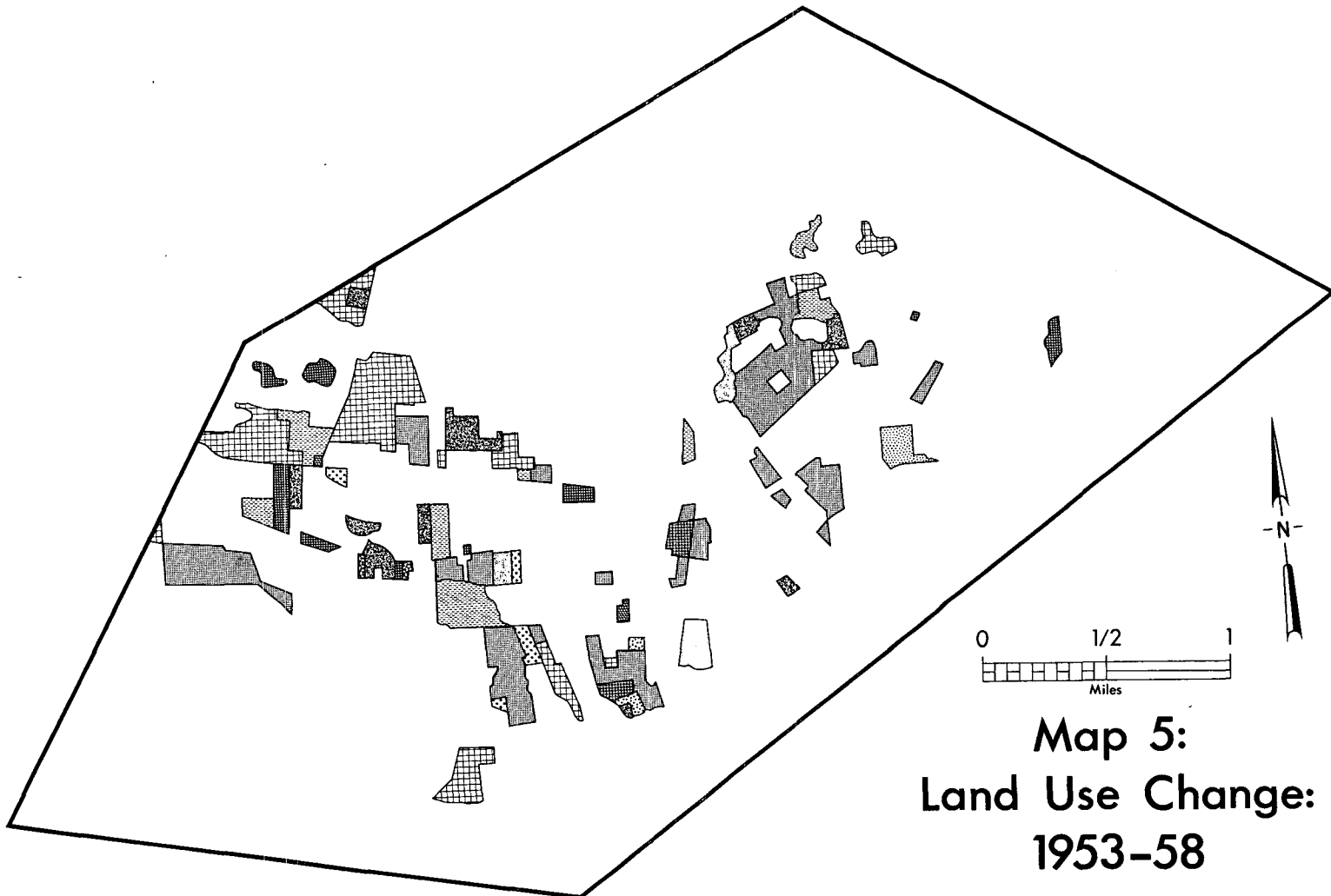

Map 5:
Land Use Change:
1953-58

Land Use Input Type Acres		TABLE 7 LAND USE SUCCESSIONS - WALNUT VALLEY, 1953-58 An Intra-regional input-output analysis																			Totals		Land Use Output 1958		
		Agricultural Demand Sector												Urban Demand Sector											
From	To	1. GC	2. C	3. PC	4. CA	5. W	6. PW	7. WA	8. A	9. FC	10. RC	11. MG	12. GR	13. UR	14. UI	15. UC	16. URe	17. UIIn	18. UA	19. UV	20. V	Rows 1-20	Cols. 1-20		
1. GL	868		54		20					174	24	56		27						6			361	0	507
2. C	1314			10						176	8			20									214	54	1154
3. PC	91									6				24						21			51	10	50
4. CA	24									15													15	20	29
5. W	1207						203	63		290				33	27					37			653	0	554
6. PW	134									20				8						5			33	203	304
7. WA	40									23													23	63	80
8. A	13																						0	0	13
9. FC	3020										23			323	60	3			17	90			516	889	3393
10. RC	285																						0	55	340
11. MG	3157									39				65						118			222	56	2991
12. GR	3200									40				35	23					34			182	0	3018
13. UR	229																						0	593	821
14. UI	66																						0	149	215
15. UC	6																						0	3	9
16. URe	0																						0	0	0
17. UIIn	156																						0	0	156
18. UA	230																						0	47	277
19. UV	321									42				43						24			109	305	517
20. V	22663									14				15	39								78	0	22586
Column Total	37,023	0	54	10	20	0	203	63	0	889	55	56	0	593	149	3	0	0	47	305	0		2447	2447	37,023

half of the study area as scattered industrial parcels and what soon may be industrial parcels (UV); residential growth centers on La Puente but has made some inroads into prime citrus acreage in Rowland Heights and into walnut groves where the City of Walnut would form next year (Maps 2 and 5). Housing was of two types, a pattern that continues in ensuing periods: La Puente development involved lower cost, single family housing (Plate 3). In the other instance, housing was more spacious, with large lots and appurtenances - horses and corrals - in keeping with "rural living" (RA Zones) (Plate 4). Industrial development required a waste disposal site nearby and a location in the San Jose Hills was developed for that purpose. Urbanized agriculture - poultry - occupied Rowland Heights (Plate 5), and commercial activity was also introduced. The larger dairy in La Puente expanded and a small shopping center was also developed there (Plate 6). Two sizeable parcels in the center of the study area were row cropped.

Urban uses were fairly selective as to the type of land they chose - land that was easy to develop and clear. Residential uses grew by 593 acres, 323 of which were formerly field crops, 65 in mown grasses, 35 in grazing, and 15 were vacant, or, 436 in total involved little development cost. Industry was similarly selective.

Most evident, however, was the trend toward agricultural disinvestment, particularly in walnuts which declined throughout the map (poor increased by 203 acres and abandoned groves, by 63 acres), and were essentially halved in acreage in these five years. Many growers, particularly those in the soon-to-become City of Walnut and in the western half of the study area, let the groves deteriorate or simply disinvested. Perhaps this was due to the tenuous city-in-the-process status and the long-term plans of the City of Industry. Another important event in walnut production was the change of 290 acres to field crops (disinvestment in lieu of reinvestment, replanting, on a long-term basis).

Citrus suffered similar changes: good citrus was reduced by 361 acres, but only 54 declined in quality and only 20 were abandoned. Less intensive agriculture - field crops, 174 acres, row crops, 24 acres, and mown grasses, 56 acres - absorbed 254 acres of producing citrus groves.

Conversions of arboreal crops to field crops (a change in the type of use) were common in this period (704 acres). Land owners, perhaps to enhance

development potential, chose to disinvest and absorb short-run losses by allowing lower paying field crops to be substituted in lieu of continued maintenance of an arboreal culture system (note the parcels in the western half of the study area, in Rowland Heights, and in Walnut, Map 5 and Table 7, column 9). Additional acreage (510 acres) was being input to field crops by 1958 for another building cycle that, in all likelihood, would soon absorb this easily developed land. Trees were cleared without regard to quality to enhance development potential when anticipation was highest.

In another instance, rather than disinvesting, some land owners sold producing groves, as is (47 acres of good and average citrus, 60 of walnuts), to developers. Urban use succeeded agriculture by a direct conversion method, without passing through a disinvestment stage. This and the previous case illustrate the great incentive to sell and develop land in this period. Perceptions of windfall gains were high.

Quality declines in citrus are not common, suggesting that: 1) growers foresaw a time when they could convert acreage to other uses more profitably; 2) that the substitution of other crops for citrus was economically not imperative because prices, yields, and returns were high; or, 3) citrus groves were peripheral to the areas most in demand for urban use. With substantial acreage available in Rowland Heights and eastward, urban succession was still some time off.

Without additional photo coverage, e.g. for 1955-56, it would be difficult to separate this long five year span and focus more closely on the time when changes began. One would expect that 1955 land use would be similar to 1953. Perhaps the disinvestment stage would be common since the plans to incorporate the City of Industry were under way. The greatest change is likely to fall in the 1955-58 period. Between 1958-60, we have a sufficiently short period in which to test the validity of these trends.

LAND USE IN 1960: CHANGES SINCE 1958

Urban land use changes (1,180 acres) have begun to surpass those concerning agriculture (804 acres). Residential land use expanded dramatically, by 905 acres. La Puente's last major acreages of agricultural land were absorbed and the city's growth subsided after 1960 (Figure 1). Development pushed into Hacienda and Rowland Heights to the east and into

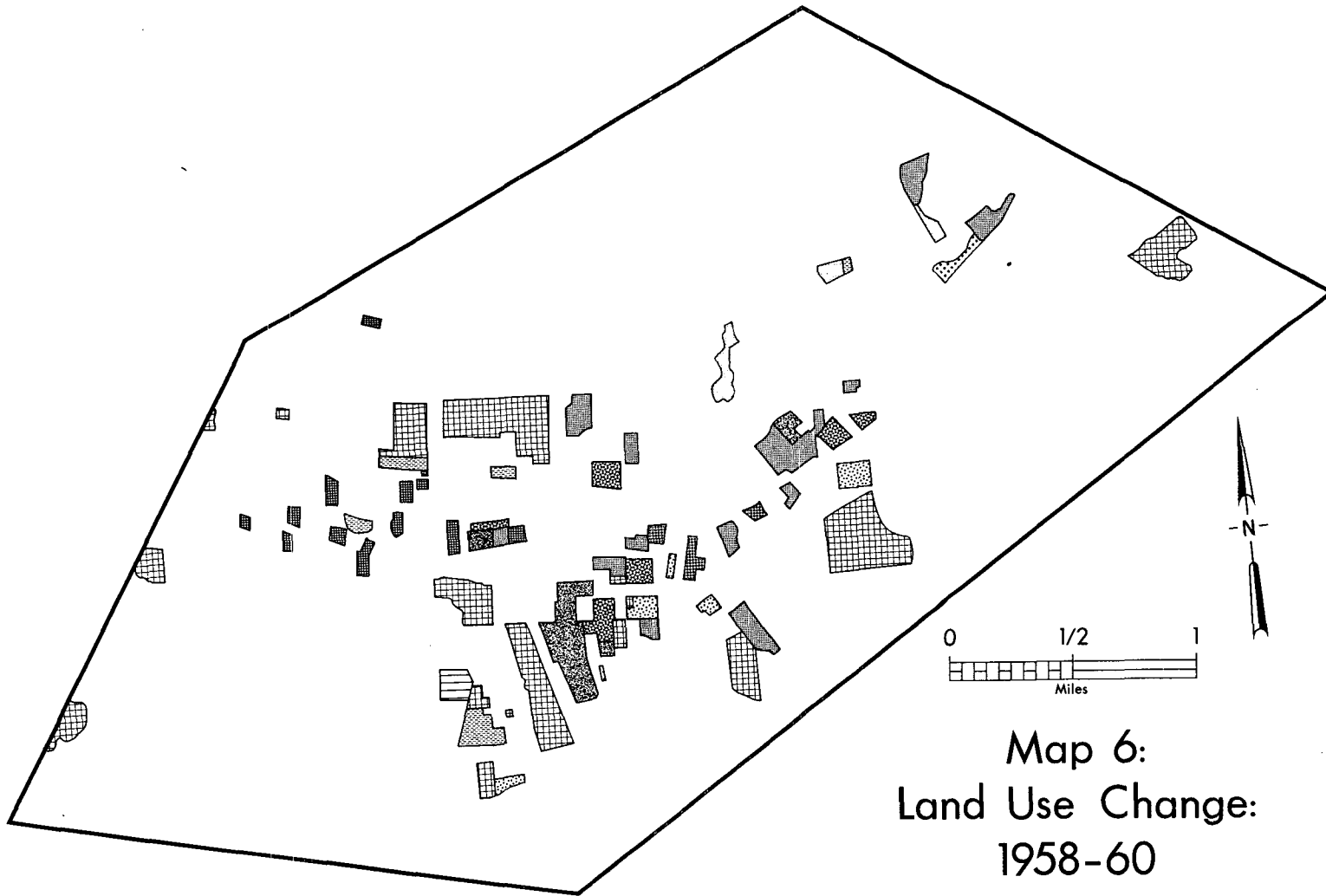

Map 6:
Land Use Change:
1958-60

Land Use Input		TABLE 8																				Totals		Land Use Output 1960
		LAND USE SUCCESSIONS - WALNUT VALLEY, 1958-60										An Intra-regional input-output analysis												
Type	Acres	Agricultural Demand Sector										Urban Demand Sector												
From	To	1. GC	2. C	3. PC	4. CA	5. W	6. PW	7. WA	8. A	9. FC	10. RC	11. MG	12. GR	13. UR	14. UI	15. UC	16. URe	17. UIIn	18. UA	19. UV	20. V	Rows 1-20	Cols. 1-20	
1. GL	507			20	14					35				47					3	46		165	0	342
2. C	1154			111	70					70	14			47	6					5		323	0	931
3. PC	50									27												27	131	154
4. CA	29																					0	84	113
5. W	554						185			51					16					22		274	0	280
6. PW	304													46								46	185	443
7. WA	80										34											34	0	46
8. A	13																					0	0	13
9. FC	3393										33	12		200	87					23		355	290	3334
10. RC	340													56								56	41	325
11. MG	2991									70	8			83		24						185	73	2879
12. GR	3018									8				80		15						103	0	2915
13. UR	821																					0	905	1726
14. UI	215																					0	109	324
15. UC	9																					0	0	9
16. URe	0																					0	39	39
17. UIIn	156																					0	10	166
18. UA	277													25								25	21	273
19. UV	517													192								252	96	361
20. V	23585													129				10	18			139	0	22,466
Column Total	37,023	0	0	131	84	0	185	0	0	290	41	73	0	905	109	0	39	10	21	96	0	1984	1984	37,023

Diamond Bar. Two types of housing again appear: better housing with large lots on hilly terrain, and cheaper tract housing with small lots on level terrain(Plates 7 and 8).

Residences increased despite the fact that much of Walnut Valley was set aside for regional industrial growth. Each use responds to different growth factors: residential growth responds to local or sub-regional population growth and land demand. Walnut Valley, being relatively undeveloped, absorbed a proportionally greater share of growth and housing demands than the remainder of eastern Los Angeles County which was comparatively urban. Industrial expansion, on the other hand, responds to the total regional or metropolitan growth and to stringent locational factors which select only those industries that find opportunities in Walnut Valley acceptable. Twelve parcels (109 acres) were developed in this period by major industrial companies.

Urban fringe uses are still common. Urban agriculture - the feed lots - expanded (Plate 9). More of a barometer, however, is the establishment of a cemetery in the study area (URe, Plate 10). Row crops are concentrating in the center of the study area and continuing a pattern begun in 1958. Row cropping is likely to be greatly restricted given the strictures of leasing mentioned above, the scarce technologies involved, and environmental conditions, and concentrations may represent agglomerative tendencies, scale economies, or the diffusion of a practice among the smaller land owners of that area.

Two years has given land owners additional time to reappraise development potentials and it was found that between 1958-60, economic conditions had changed and land owners utilized the three planning strategies in different proportions.

Direct conversions of tree crops to residential use were reduced to 151 acres. The notion that "one day a citrus grove, the next a subdivision" is not quite correct for this and any other time period. Either an interim land use stage (disinvestment in lieu), or a lengthy period when the groves decline (simple disinvestment) follows before urban uses succeed, depending on the location, zoning, demand, and other elements of planning strategy. Residentially zoned property, if demand is high, often converts directly to urban use (irrespective of use). Disinvestment in lieu seems more practical

if sales must be improved, or a land owner cannot wait for a more opportune selling period. When demand is lowest, disinvestment appears workable given that long-run prospects - yields and returns - among different groves justify this decision.

Agricultural-urban conversions again selected easily developed land. Industrial and residential uses absorbed 87 acres of field crops, and 547 acres of field and row crops, grasses, and grazing and vacant land, respectively, to meet their demands. Field crop acreage was built upon faster than land owners disinvesting in lieu could input acreage into the field crop category (355 acres out, 290 acres in). The above strategy, second-most important between 1953-58, is even less important in this period. Absorbing the previously prepared acreage (land prematurely cleared to enhance development potential in the 1953-58 period) and other easily developable land was the path conversion processes followed (the cycle was complete) to urban uses.

Tree crop losses were commonplace. Walnut groves were halved in size in two years (554 acres to 280 acres); a qualitative decline accounted for 185 acres (poor category). Good and average quality citrus was reduced by one-third (1,661 acres to 1,162 acres), much of which fell into the poor (131 acres) and abandoned (84 acres) categories. Arboreal disinvestment was an areally more important strategy than disinvestment in lieu (146 acres of citrus and 51 of walnuts were absorbed by less intensive agriculture). Direct conversion to urban uses was also a less important land use plan than it was in the previous period (119 acres of citrus passed into urban use without any disinvestment). The greater use of disinvestment planning, 1958-60, indicates a awareness of market conditions and a tempering of earlier profit perceptions. The better examples of this strategy lie in areas where opportunities for immediate conversion are slim and urban use is likely to succeed much later e.g. in the eastern and central parts of the study area.

Land owners realized what the existing parameters were to observe and the development character changed between 1958-60. By the close of the next period, a five year span which obscures many development trends, the dynamic influence of the Pomona Freeway, under construction and complete to the center of the study area, would certainly accelerate development and change the importance of each planning strategy.

LAND USE IN 1965: CHANGES SINCE 1960

By 1965, after a period of great economic growth nationwide, urban land use change has come to dominate all activity in the valley. Agricultural uses are still more extensive than urban uses (Table 6), 9,511 as opposed to 5,946 acres, but while 636 acres changed agriculturally (disinvestment), 2,641 acres succeeded and were directly converted to higher uses in this period (a summary table of planning strategy appears later, in Table 12). With twice the amount of urbanized land remaining in agriculture, there is potential for considerable future growth without having to convert vacant land to more intensive land use functions.

Urban residential successions account for 1,828 acres, or over half the activity (3,342 acres). Industry expanded by the same ratio - one acre for every eight to nine residential acres - as it had in the past (Table 6), and more industrial use extends into the eastern half of the study area. Urban services filled out as several schools and two large golf courses were constructed (Plate 11). Commercial activity, represented by two large shopping centers and "urbanized" agriculture (a nursery attracted by the freeway) added 47 and 20 acres, respectively, to the urban matrix (Plate 12). Additional land was prepared for the next wave of successions (152 acres).

Land owner planning decisions were as hurried as between 1953-58, but with one exception - different strategies were employed. In the earlier period, the freeway announcement precipitated a flurry of development emphasizing disinvestment in lieu planning and some direct conversions. No longer need one anticipate the freeway. The actual construction stimulated much new building and the succession of higher uses on 2,262 acres of land. Land easiest to develop was preferred as before, e.g. Table 9, Rows 9-13, supplied 1,217 acres of developable land for residential use and 149 for industry. Direct conversion of good to average tree crops (Rows 1-2,5) to urban residential use (without disinvestment, the only economic justification being an immediate sale, as is) supplied 322 acres for urban use (256 of citrus; 66 of walnuts). Disinvested walnut (170 acres) and citrus (54 acres) acreage of previous periods was succeeded by residential use. Disinvestment in lieu was unpopular (86 acres of citrus to field crops), as compared to 1953-58 when 704 acres converted to less intensive agriculture. Urbanization was so intense that it absorbed four square miles (1075 km²) of agricultural land in

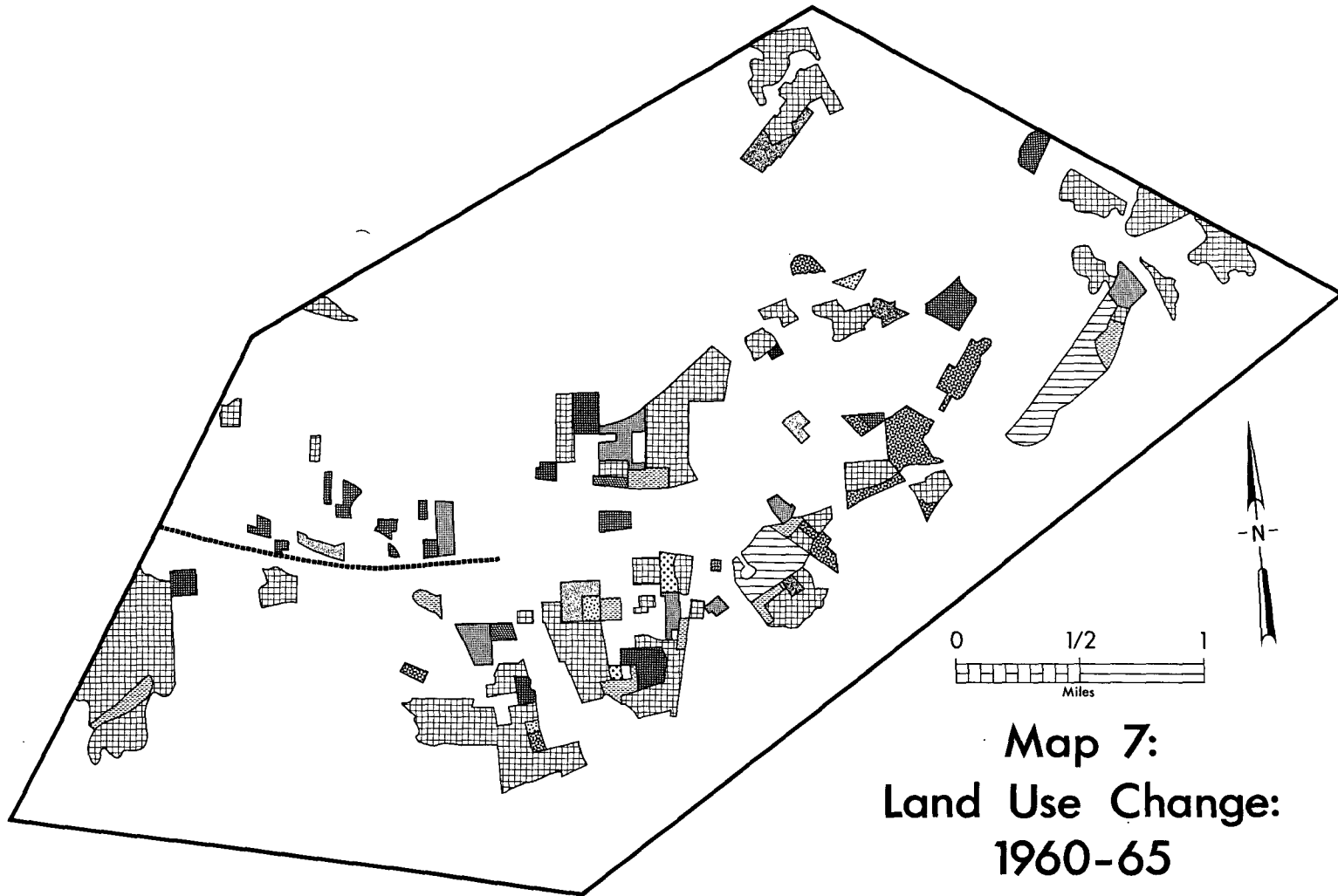

Map 7:
Land Use Change:
1960-65

Land Use Input Type Acres		TABLE 9 LAND USE SUCCESSIONS - WALNUT VALLEY, 1960 - 65 An Intra-regional input-output analysis																			Totals		Land Use Output 1965		
		Agricultural Demand Sector										Urban Demand Sector													
From	To	1. GC	2. C	3. PC	4. CA	5. W	6. PW	7. WA	8. A	9. FC	10. RC	11. MG	12. GR	13. UR	14. UI	15. UC	16. URe	17. UIIn	18. UA	19. UV	20. V	Rows 1-20	Cols. 1-20		
1. GC	342			15	7									166	11								199	0	143
2. C	831			236	41					112				90	15				20	20			539	0	297
3. PC	154													30	14	13							62	251	343
4. CA	113													24									29	48	137
5. W	280						82	52						66	5			6					211	0	69
6. PW	443													170	20			14					204	0	321
7. WA	46																						0	52	98
8. A	13																						0	0	13
9. FC	3334										4			296	135	16	16	23		17			577	231	2988
10. RC	325									38				39			75			7			159	4	170
11. MG	2879									41				438	14	7	190			42			732	0	2147
12. GR	2915													120									120	0	2795
13. UR	1726																						0	1828	3554
14. UI	324																			13			13	212	523
15. UC	9																						0	47	56
16. URe	39																						0	302	341
17. UIIn	166																						0	113	279
18. UA	273																						0	20	293
19. UV	361													63	4								107	152	406
20. V	22,466													326			21			53			400	0	22,056
Column Total	37,023	0	0	251	48	0	82	52	0	231	4	0	0	1828	212	47	302	113	20	152	0	3342	3342	37,023	

five years irrespective of the quality of use. It seemed unnecessary to enhance or let land "ripen" for development in a "boom" period, and the only simple disinvestment patterns that exist are concentrated in the eastern half of the study area where development potential rose considerably but was not sufficiently high or "ripe".⁴ Poor quality tree crops exceed the good quality for the first time (citrus, 455 of poor quality vs. 493 good groves; walnuts, 419 vs. 69).

Until this time, simple disinvestment processes involved only tree crops and their conversion to other uses. With little tree crop acreage remaining, the character of the evolving urban fringe land use should change. Barley raising has become so popular with the phasing of intense agricultural land uses through this extensive use in slack growth periods, that despite rapid urbanization which selects this easily developed land, field crop acreage remains large (3,020 acres in 1953, 2,695 in 1970). What direction the disinvestment process may take when barley raising is the only agriculture left remains to be seen.

LAND USE IN 1969: CHANGES SINCE 1965

From 1965 to 1969, economic trends slowed most construction activity nationwide. Walnut Valley was no exception. Since most of the trends established earlier were repeated, we are able to see how a different set of economic conditions modify the rural-urban conversion cycle.

Urban residential land use accounts for over one-third the input-output activity (462 acres out of 1,232). This growth concentrated on developing remnant parcels of earlier expansion periods and on enlarging existing subdivisions. Industry grew disproportionately relative to residential growth (217 acres for industry, 462 for residences); institutional (94 acres) and commercial (28 acres) expansions were similarly large. A filling in with necessary services seems to be the trend - those activities

⁴Of course, age of the groves may be a factor. Uniform decline presupposes either of two conditions: the groves were equally aged, or all groves in the area suffered the same economic pressure. Given their conformity with other patterns, the latter condition seems more likely the actual case.

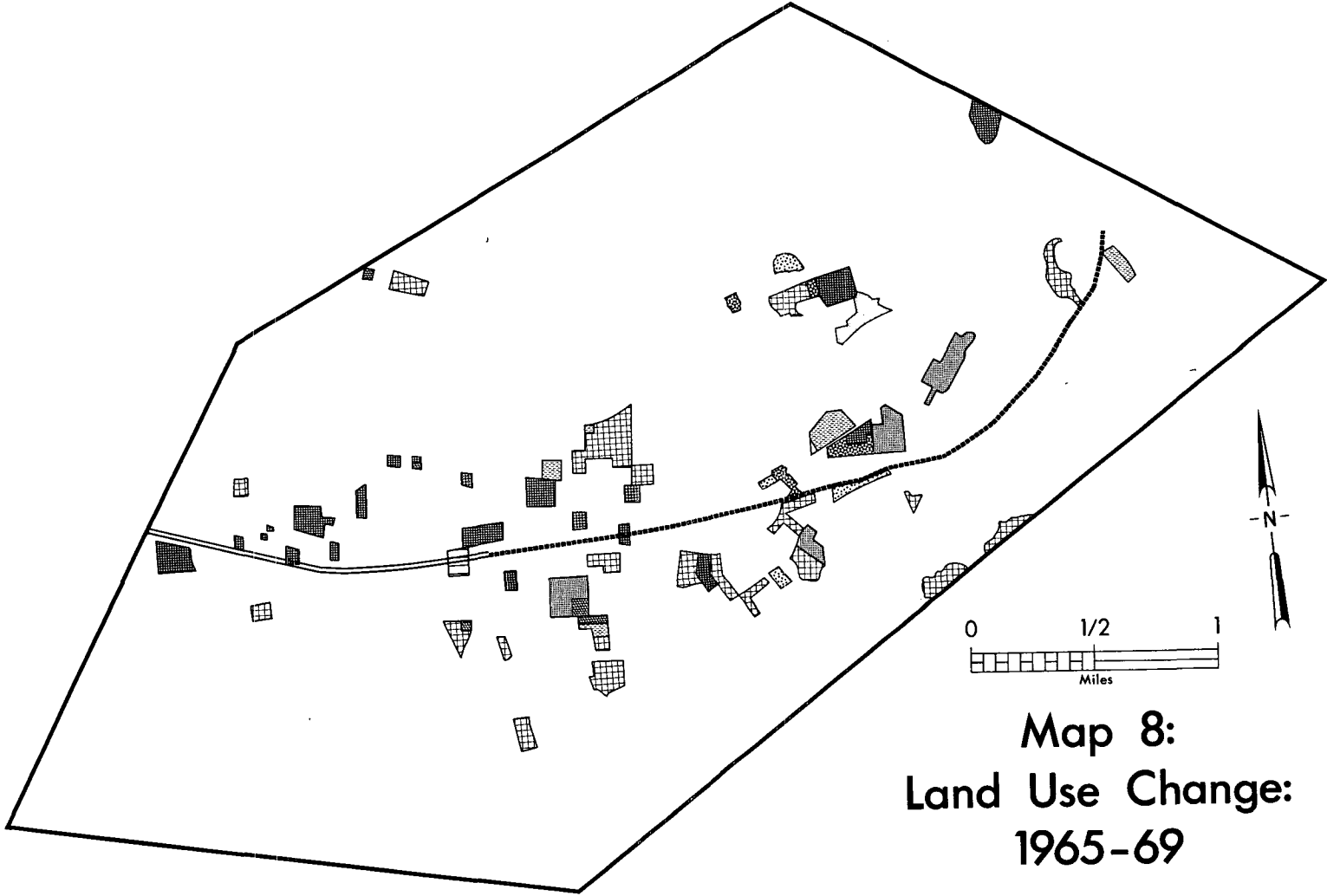

Map 8:
Land Use Change:
1965-69

Land Use Input		TABLE 10																				Totals		Land Use Output 1969	
		LAND USE SUCCESSIONS - WALNUT VALLEY, 1965 - 69 An Intra-regional input-output analysis																							
Type	Acres	Agricultural Demand Sector										Urban Demand Sector										Rows 1-20	Cols. 1-20		
From	To	1. GC	2. C	3. PC	4. CA	5. W	6. PW	7. WA	8. A	9. FC	10. RC	11. MG	12. GR	13. UR	14. UI	15. UC	16. URe	17. UIIn	18. UA	19. UV	20. V				
1. GC	143													6									6	0	137
2. C	297			53	5					59				34	12	2		9		21			195	0	102
3. PC	343				31					64				18		8				44			165	53	231
4. CA	137									6				6		10		11					33	36	140
5. W	69													22	11								33	0	36
6. PW	321											25		8	17					14			64	0	257
7. WA	98									26													26	0	72
8. A	13																						0	0	13
9. FC	2988										22			159	110			22	63		14		390	155	2753
10. RC	170													10	4								14	22	178
11. MG	2147													45									45	25	2127
12. GR	2795													22					11				33	0	2762
13. UR	3554																						0	462	4016
14. UI	523																						0	217	740
15. UC	56																						0	22	363
16. URe	341																						0	94	373
17. UIIn	279																						0	0	264
18. UA	293														23								23	0	264
19. UV	406														64		4						68	118	456
20. V	22,056														45	63	4				25		137	0	21,919
Column Total	37,023	0	0	53	36	0	0	0	0	155	22	25	0	462	217	28	22	94	0	118	0	1237	1237	37,023	

not closely related with general economic problems - schools, businesses, and factories of major corporations.

Row cropping, a relatively intensive agricultural type as compared to the dominant field cropping patterns (Plate 13), increases in the center of the study area at the expense of field crops and continues a minor trend begun in 1958 (even though the absolute total is less than in 1960 when the large fields in Diamond Bar were producing). This substitution of intensive for extensive agriculture suggests a second round intensification after the earlier market-oriented agricultural fringe has passed through disinvestment in lieu planning. Newer conditions warranted a reappraisal of that plan. Intensification may be a practical strategy for offsetting long-term carrying costs on land zoned for commercial or industrial use, or may be a useful interim use in a stagnating growth cycle that is of such duration that a reasonable short-run return can be earned.⁵

The main thrust in urban development, however, succeeded on land with low development costs (Rows 9-13, Table 10; 281 acres for residences, 177 for industry), the largest part of which was field crop acreage. Direct conversion of tree crops to urban use utilized only 40 acres of citrus and 22 of walnuts, and disinvested crops of earlier cycles (24 acres of poor citrus, 8 of walnuts) were also succeeded by urban use. Tree crops are being replaced by field crops in the eastern half of the study area in anticipation of urban succession, and declines (simple disinvestment) are also extensive there.

The succession of urban uses on field crop acreage is an all too obvious prognosis of the future development of the urban fringe in Walnut Valley. While further disinvestment seems impossible (Sinclair claims disinvestment zones do not fit areas of small grain farming), several other choices seem possible: 1) economic stagnation may warrant a resurgent intensified row-crop agriculture at least on the smaller parcels, particularly those zoned for commercial or industrial use; 2) interim urban uses of a

⁵ There is evidence that higher-return agriculture may be developed on land whose highest use will be realized at some long distant date. For example, in 1969, in Rowland Heights, 161 acres of undeveloped commercially zoned property were used as follows: 34 acres were devoted to row crops, 43 to poor citrus, 6 to abandoned citrus, and 78 to field crops. Of the remaining 145 acres of row crops, 141 acres were industrially zoned.

short-run nature may be devised such as, semi-permanent dwellings - trailer courts, golf driving ranges (URe, 22 acres, Map 8), etc. (Plate 14). More study of the disinvestment strategy seems warranted to test whether similar patterns evolve in other areas, either in regions of different agricultural specialization or in semi-permanent urban land use.

LAND USE IN 1971: CHANGES SINCE 1969

Two years of a relaxed economic pressure permitted a greater ease of financing single family housing which is reflected in residential land use expansion (401 acres out of 585 transacted). Commercial land use increased significantly and shows a tendency to lag behind residential construction, e.g. more was built in 1965-69 than in 1960-65 when residential construction was greater (Plate 15). Other increases in urban use were minor and in all probability the next land converted for urban use (99 acres of UV) would be used for the purposes above - residential and commercial use.

Little of the remaining tree crop acreage was used to meet this demand, and the emphasis again was on easily developed land. One so-called "new town in town" development in the northeastern part of the study area accounts for the bulk of the residential acreage (Plate 16). In 1969, a small dairy was replaced by this construction, and by 1971, the "new town" expanded extensively into vacant acreage. The likelihood of considerable further population growth in this extension of West Covina appears good (Figure 1, May 2). Large areas of hilly terrain are individually owned and these may develop similar to the example above, a development with substantial open space (for passive recreational use, not active, owing to the difficult terrain), not as standard subdivisions with rectangular grids but in condominium or town house fashion with common open spaces (Regional Planning Commission, 1966).

Agricultural land use change was imperceptible (much due to the extremely small scale - 1:120,000 - photographic imagery used), and it would be difficult to determine qualitative changes in this key indicator of fringe evolution without extensive field checks.⁶ Two trailer courts,

⁶ Data from the Los Angeles County Agricultural Commissioner show that row crop acreage was halved between 1969-70. All other crop data, excepting nurseries, show small declines in that one year.

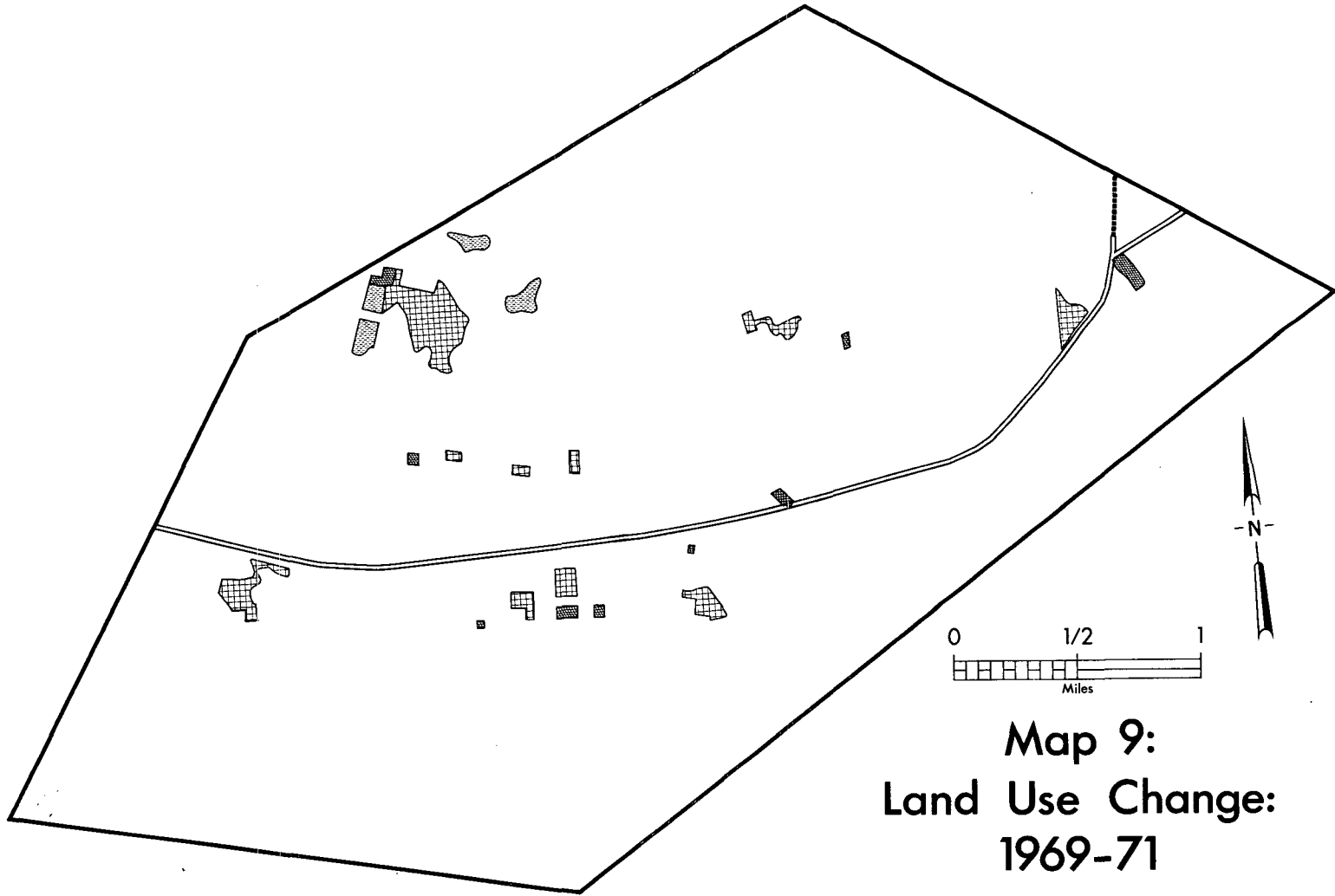

Map 9:
Land Use Change:
1969-71

Land Use Input		TABLE 11 LAND USE SUCCESSIONS - WALNUT VALLEY, 1969 - 71 An Intra-regional input-output analysis																				Totals		Land Use Output 1971	
Type	Acres	Agricultural Demand Sector												Urban Demand Sector						Rows 1-20	Cols 1-20				
From	To	1. GC	2. C	3. PC	4. CA	5. W	6. PW	7. WA	8. A	9. FC	10. RC	11. MG	12. GR	13. UR	14. UI	15. UC	16. URe	17. UIIn	18. UA	19. UV	20. V				
1. GC	137																						0	0	137
2. C	102																						0	0	102
3. PC	231																						0	0	231
4. CA	140																						0	0	140
5. W	36																						0	0	36
6. PW	257													6									6	0	251
7. WA	72															10							10	0	62
8. A	13																						0	0	13
9. FC	2753													168	10	11					22		211	0	2542
10. RC	178																						0	0	178
11. MG	2127													35									35	0	2092
12. GR	2762													2									2	0	2760
13. UR	4016																						0	401	4417
14. UI	740																						0	15	755
15. UC	84																						0	70	154
16. URe	363																						0	0	363
17. UIIn	373																						0	0	373
18. UA	264																						0	0	264
19. UV	456													8	5	40							53	99	502
20. V	21,919													182	9						77		268	0	21,651
Column Total	37,023	0	0	0	0	0	0	0	0	0	0	0	0	401	15	70	0	0	0	99	0	585	585	37,023	

developed on property zoned for commerce (Plate 17), totalling 42 acres, were added to the residential land use category, and high density housing (15-20 dwelling units per acre, Plate 18) were also built in commercial zones (both are permitted by the zoning). Continued research is needed to identify the nature of urban growth now that its processes are known. What happens when the remaining agriculture has become so severely altered, and what is the nature of the disinvestment phenomenon in other agricultural areas?

EVOLVING LAND USE ON THE URBAN FRINGE

Theoretically, land owners may need to change the land use as often as there are distinct changes in land holding costs. Environmental, economic, and social restraints hold them to a few choices, however. Agriculture which intensified the use of its production factors can generally coexist with urban land uses and we tend to expect farming to be intensive in a von Thünen sense on the fringe of American cities. The activities are often stereotyped - nurseries, dairies, perhaps poultry farms. Increasingly we find these uses cannot prevail, and means of protection from encroachment or extreme manipulation of the production factors - "industrialized" dry lot dairying - are devised to allow their persistence (Fielding, 1962; Gregor, 1963). Social factors are the key. The record shows that taxes, public complaints, pilferage, zoning and rising costs forced agriculture from the fringe. Recently, California's Land Conservation Act (Williamson Bill, AB 3117, 1965), introduced a contrary philosophy based largely on the need for open space that attempts to stabilize the agricultural fringe on a long term basis (Snyder, 1966). It can fairly be said for fringes of American cities that a well-developed agriculture exists gratis of the population and not of the market system. Those areas that remain in agriculture attest to a high refinement through environmental, economic, and social selection.

Urban sociologists have dealt with the quality of fringe occupance and this appears in many places (Ray, 1970). While disinvestment patterns in housing were examined, they overlooked the topic as an indicator of urban growth and saw sub-optimal land use only in its sociological implications (Firey, 1946). Disinvestment is an economic expression of the infeasibility of investment in a dynamic planning situation. Wingo (1966) coined the term to refer to obsolescence in structural land uses. Major public investment

projects that inject new development incentives into an area, creating a state of flux in planning, form an opposite dynamic state. Disinvestment is an individual decision facing economic precariousness which, aggregated geographically, is a precursor of rural-urban land use conversion. This event takes different courses depending: 1) on the information available to the land owner; 2) on the urgency with which he perceives a need to change the land use; and 3) on the kinds of alternatives (environmental, economic, and social) open to him. Economic resources and conditions help determine the strategy. Large and small parcel land owners, among other sociological differences described in another place (Kaiser, et al., 1967), have dissimilar objectives and plans: should one maximize benefits or find other alternatives? A changing time scale makes the decision only more complex. For example, some parcels in Rowland Heights, good citrus in 1953, were changed to field crops by 1958 in expectation of urban succession. Disinvestment was made in lieu of continued maintenance and to enhance development potential. By 1965, the land was subdivided and residential use succeeded the disinvested agriculture, completing the conversion cycle in two steps. The pattern is repeated throughout the study area. Other strategies below accomplish the same result - a conversion.

Economic conditions and localized growth incentives, i.e. the freeway, affect this decision. For example, there are five types of planning strategy each with its own characteristic land use change transactions (Table 12):

- 1) intensification of the agricultural usage. This plan decreases as a land use alternative in the ideal von Thünen sense as the total environment becomes more urban and as Sinclair disinvestment becomes the planning practice.
- 2) direct conversion of intensive, productive agriculture to urban use. A small percentage of land owners utilize this plan, particularly when sales are likely as in the "boom" periods.
- 3) succession of extensive agriculture by urban uses. Disinvested acreage, succeeded by urban uses, increased from 37.0 percent of all land use change activity in the earliest to 100.0 percent of the land use transactions in the latest period.
- 4) disinvestment in lieu of reinvestment in a planning cycle that is longer than the only alternative, a less-optimal land use. It is an intermediate strategy that is practical as long as a relatively

TABLE 12

SUMMARY OF LAND USE TRANSACTIONS: BY TYPE OF PLANNING STRATEGY
(in acres and percentage of all land use change)

Strategy	Planning Period									
	1953-1958		1958-1960		1960-1965		1965-1969		1969-1971	
(1) <u>Intensification</u>	213	8.9	122	6.1	65	1.9	22	1.8	0	0.0
(2) <u>Direct conversion</u>	144	5.9	189	9.5	379	11.3	117	9.5	0	0.0
(3) <u>Succession</u>	906	37.0	988	49.6	2,262	67.8	824	66.8	585	100.0
(4) <u>Disinvestment in Lieu</u>	754	30.8	197	9.9	112	3.4	148	12.0	0	0.0
(5) <u>Disinvestment</u>	430	17.6	488	24.6	524	15.7	121	9.8	0	0.0
TOTAL LAND USE CHANGE*	2,447 acres	100.0%	1,984 acres	99.7%	3,342 acres	100.1%	1,232 acres	99.9%	585 acres	100.0%

Notes: (1) Any agricultural use or UV use to UA, FC, MG, GR; CA, or WA to RC; GR, MG, V, to any other agricultural use.

(2) GC, C, W, RC, UA, to all other urban uses.

(3) PC, CA, PW, WA, FC, MG, GR, V, to all urban uses; UV or UA to any other urban use.

(4) GC, C, PC, W, PW, RC, to FC, MG, or GR use; GC, C, PC, W, PW, to RC use.

(5) GC, W, to C, PC, CA, or PW, WA use; RC to FC, MG, or GR use; PC, CA, PW, WA, to FC, MG, or GR use; UV to any agricultural use; FC to MG, GR, or V use. There is also one case of a citrus packing plant being razed (UI to UV).

*Totals do not add to 100.0 percent due to rounding.

Source: Aerial Photo Interpretation.

more intensive agriculture exists in which to disinvest, and is generally practiced to enhance sales, e.g. the 1953-58 period when the freeway was to be built vs. the 1960-65 period when it was being built.

- 5) disinvestment in a simple sense such as the allowing of intensive agriculture to deteriorate without reinvestment or continued maintenance. Disinvestment serves as a plan when sales and development are likely to be realized in a period shorter than the planning cycle of that crop, and when short-run disinvestment in lieu planning is unfeasible given clearance costs, irrigation, or other improvements necessary to bring the land into production.

Choices of the development/disinvestment strategy closely follow economic trends as reflected in housing constructed in Los Angeles County (Figure 2). Major construction periods are preceded by disinvestment in lieu planning although the data from widely spaced study periods are too sparse to form good conclusions. How land owners perceive development incentives deserves more attention.

As the pool of disinvested acreage enlarges, successions will increasingly dominate land use transactions. Certain social costs accumulate in the interim. Some land owners continue to farm and hold out against encroachment for individual, particularized reasons, e.g. a tradition must be perpetuated, and a limited agriculture may persist. Most land owners, however, plan their land's use in keeping with economic principles and practice disinvestment or sub-optimal land use. This may be advisable to an individual but not to society in terms of the increased transportation costs, aesthetic problems, higher taxes, etc. they incur. Individuals may also suffer losses. For example, a smaller land owner, knowing that the area is destined for urban use, attempts to judge the onset of development. Zoning and plans tell him the development potential and what he may realize when the property is sold. He must plan for an interim use while costs rise. Eventually his production becomes marginal and disinvestment is his only alternative. He then judges how soon he can sell the land. In competition with other land owners, he often rushes into the decision and disinvests in lieu if sales seem imminent. He cannot face high operational costs and must gamble by removing producing groves to enhance sales and rid himself of the land while sales "boom" (e.g. 1953-58, 1960-65), or if he cannot sell, he must bear those costs without as high an interim return (perhaps row crop increases are the result of slowing

FIGURE 2

ANNUAL POPULATION INCREASE AND NUMBER OF FAMILY DWELLING
UNITS AUTHORIZED: LOS ANGELES COUNTY

Figure 2: Rather than following a fluctuating graph, housing constructed has a more consistent variation which appears to be related to general economic conditions, e.g. the low points occur during the Korean War, the mild "recession" of the late 1950's, and the tight money conditions of the mid-to-late 1960's. Population tends to accumulate ahead of housing constructed, responds belatedly and certainly not directly to population increases, and exceeds housing by a factor of two through most of this period. By comparing the differences in numbers we find that in 1950 there was almost as many homes built as there were people added to the County; in 1966, six times as many people came. Conversion processes parallel these conditions. Disinvestment was popular in those periods of economic downturn; direct conversion peaks in "boom" periods (1960-65).

development). Only those areas zoned for industry which realize their potential development later and also have high carrying costs could easily justify a long term planning procedure that includes interim land uses. Although long-run planning seems assured on the larger industrial ownerships, the industrial parks of the City of Industry have not developed an intensive agricultural use. This is in contrast to an eastern United States tradition, however, where major corporations hold blocks of industrial land which they lease to small farmers (Higbee, 1966). We further can see how a policy that stabilizes fringe agriculture can regulate urban growth as well as reduce the above social costs. Development areas may be assigned as population growth requires (Clawson, 1960).

Zoning is a social restraint that can preserve or detract from agriculture's persistence. For example, some parcels in the eastern half of the study area were farmed in good citrus in 1953. By 1958, their quality was average and they continued to produce similarly until 1969 when they were replaced by field crops (alfalfa) (Plate 19). Between this (disinvestment) and the example of premature disinvestment in lieu planning, there is much difference. The former is zoned for residences (is located in the center of the study area) and the latter (on the eastern edge of the study area, in the City of Industry, where it is likely not to succeed in use or be converted for some time) is zoned for commercial and industrial purposes. The latter's disinvestment stage was accordingly longer because of a higher holding cost over time and thus more drawn out. The current disinvestment in lieu decision reflects some recent development potential.

Other forms of social restraint, political factors such as city policies, have much to do with the conversion rate, e.g. West Covina's belated development of the San Jose Hills, 1969-71. Residential communities and the unincorporated area follow similar paths in land use conversion because zoning is the primary land use control and the land use objectives are similar. Industrial zones evolve to urban use slowly. Commercial property increases proportionate to the population and shows a tendency to be developed immediately after a population surge. Residential areas evolve quickly. In all instances, proximity to the metropolis affected the conversion rate since property in the western half of the study area evolved sooner than property in the east.

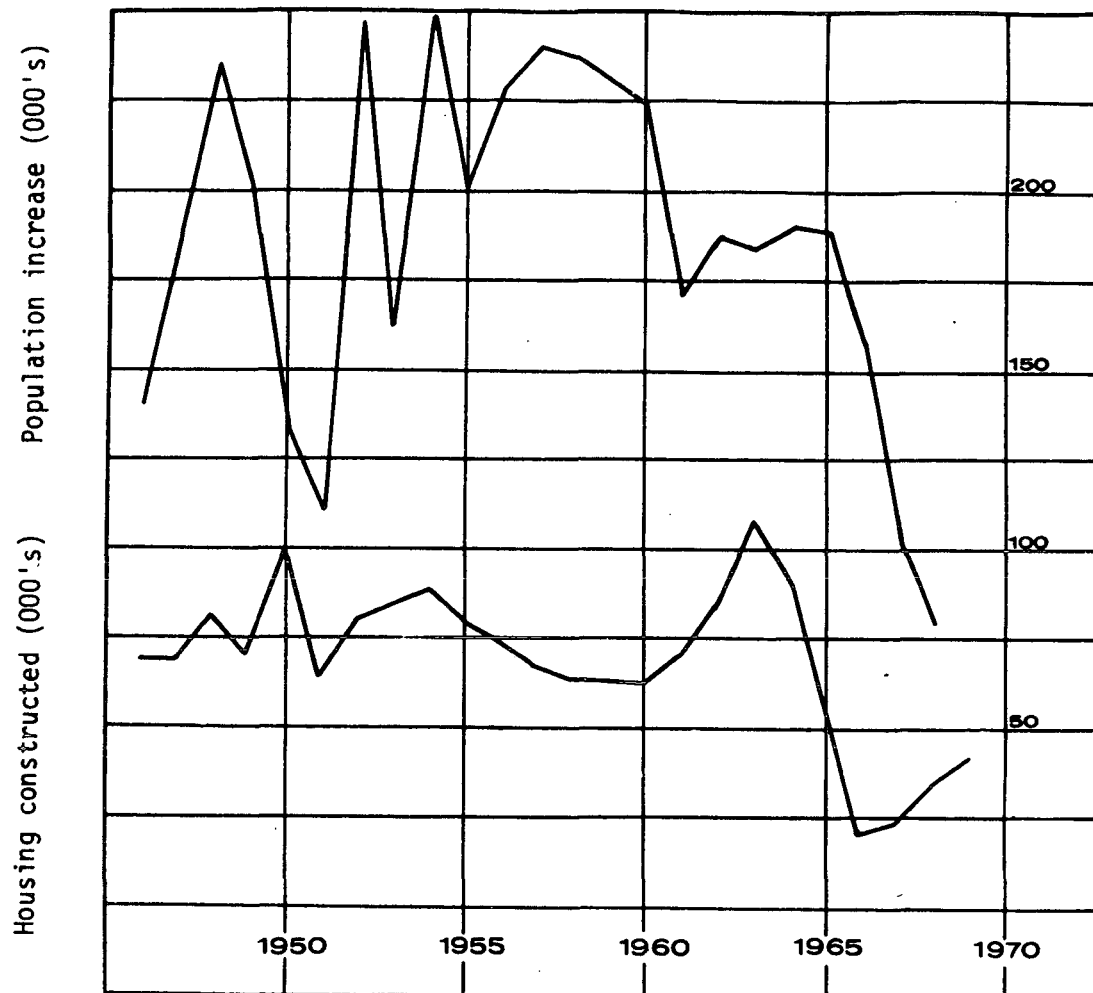
Obviously, land use conversion could be monitored by current activity transactions in the files of planning agencies. If a zone fails to perform its required land use control, or if demand requires it, planners will change and update zoning classifications. They make observations when development is complete or after numerous applications are made for piecemeal zone changes. Synoptic remote sensing methods and the input-output technique are more advantageous in designing zoning controls on the fringe because they can monitor qualitative improvement or decline in agricultural land use, the many successions of agricultural use that precede the final event of rural-urban conversion that planners see as a formal application to allow urban uses to succeed - zone changes, building permits, etc. Disinvestment patterns are preliminary to those formal and legal transactions. By responding to this expression of private initiative, well-conceived development plans can order and direct growth rather than treat it incrementally and belatedly through piecemeal zoning decisions. General plans project a twenty year goal which is rarely phased, or which sets down implementation policies that deal with interim problems, e.g. to permit or deny leapfrog development. By the time the entire plan is realized, a patchwork of differentially aged islands has developed - the "Rurban" slum (Plates 1, 2, 7, and 8).

CHAPTER IV

URBAN GROWTH THEORY AND THE RURAL-URBAN CONVERSION PROCESS

Decision-making on the rural-urban fringe requires an ability to foresee the long-term viability of a particular investment decision. In general terms, agriculture lends itself well to this situation because of its relatively mobile resource base: it has a choice of producing areas, and its other factor inputs, labor and capital, can be manipulated many ways. Urban investments are less able to fit a short-run planning schedule. Investment in the structural stock creates an inertia that resists major changes and confines minor ones within the structure. Short-run ventures are more feasible in agriculture, particularly in an urban fringe situation where plans must accommodate the changing conditions of that zone. The decisions are complex and they are often non-traditional, i.e. maximization, decisions.

Complexity results from the fact that farming is not an uniform type of activity and farmers do not have similar outlooks. There are distinctions between urban fringe farmers and farmers in the more specialized cropping regions. On the fringe, outlooks are mixed, e.g. an important regional planning question asks why farmers do and do not hold land. In a stable agricultural region the question is likely to be unasked. Knowing what types of farmer exist and where they are located helps predict land use change. For example, some land is likely to be converted and some will be witheld in large blocks. When and where the conversion may take place are necessary elements to planning orderly urban growth.

URBAN FRINGE FARMERS

Farms on the urban fringe fall into four categories, each with its own planning outlook (Higbee, 1967):

- 1) genuine farmers tend to sell their land when values rise sufficiently to give them capital gains which they reinvest to a greater productive advantage on equally good but cheaper land farther from the city. Citrus culture's dispersion from the Los Angeles Basin into southeastern California and into the Central Valley are examples of this type of farming (Gregor, 1963).

- 2) substantial land speculator and developer "farmers" may disinvest in agriculture for a while and take business losses on farm operations in exchange for higher capital gains on their real estate in the future. The hacienda system in former Spanish territories in the United States lends itself admirably to this type of "farming." Since large tracts of land cannot be digested at once and sprawl does not permit them to realize their maximum future capital gains, many modern "hacienda" owners are active in land planning (Helbock, 1968). The aggregation of small, marginal farms into industrial parks, "investment haciendas," of which the City of Industry has four totalling 666 acres, is a practice where agriculture becomes a tax loss operation until the land is ready for a more intensive urban use.
- 3) pseudo-farmers earn the majority of their income from off-the-farm labor. They are affected more by conditions in the urban than in the agricultural economy. Urban proximity gives them access to a labor market, not a market for agricultural produce.
- 4) marginal agriculturalists who farm the urban fringe are under-capitalized commercial farmers of Economic Class IV and lower (less than \$10,000 in annual sales) who have uneconomic operations that are vulnerable and who are likely to sell out or to join the ranks of the pseudo-farmers.

Only a small minority of today's census farms (22%) are economically viable enterprises (Higbee, 1967). Genuine farms, particularly Economic Class I-II farms (over \$20,000 in annual sales), are likely to stay in business even when they relocate. Other farms become increasingly marginal and eventually cease to produce (1.3 million farms in Class IV and below passed out of existence, 1949-59, Higbee, 1967). Some become pseudo-farms on the fringe of cities and their life is thus prolonged. Farms are subject to changing economic conditions like other businesses. Urban fringe conditions condense economic pressure and make decisions to produce, what to produce, and how long to produce much more complex.

DECISION-MAKING ON THE URBAN FRINGE

Every farm operator must decide, in reference to his particular location, 1) what crop or crop combination should be grown, 2) how intensively the chosen crop mix should be grown (i.e. what level of capital and labor inputs should be chosen), and 3) at what market or group of markets the resultant production should be sold, to maximize returns in the ideal sense of agricultural location theory (Garrison and Marble, 1957).

Experience has shown that maximization expresses itself in ways different from that above: basically non-economic objectives as personal profit are important, and the term "satisficing" may better fit the situation (Simon, 1957). Rather than maximizing land rents it may be beneficial in some instances to take an alternative course that is "good enough," e.g. to minimize site input demands for reasons of other satisfactions.

Land owner planning ideally leads to intensification as carrying and other costs rise, an optimization strategy. Genuine farmers may intensify until they have to relocate, others, e.g. large dairies, nurseries, feed lots, are intensive agricultural operations in character and find it relatively easy to further intensify. Otherwise viable farms are made marginal farms by the conditions of the fringe. As costs rise, they become less economic even though they use land and labor intensively; they lack capitalization to be successful. Both the above farm types tend toward optimizing practices. A non-economic satisficing procedure may take the marginal farmer in another direction, however. Some may become pseudo-farmers and reduce the intensity of land and labor use, still without capitalization, and remain attached to the land while regaining competitiveness in another industry. Both the above may sell out to the land speculator "farmer" who only satisfices, supporting a marginal agriculture because it is "good enough" as befits the economic situation. Both of these decisions create disinvestment patterns.

Farming is subjected to increasing urban pressure the closer it lies to growing urban areas. Practices must change. In the von Thünen system, land use theoretically intensifies up to the city margin given that site considerations - soil, climate - are permissive. He failed to consider a dynamic situation. Around many American cities, a contrary extensive land use zonation based on factor disinvestment intervenes between the von Thünen zones and the actual developed area (Sinclair, 1967). The rural-urban fringe of growing cities, the zone where the above production decisions are made, becomes a region of great agricultural inefficiency - non-productive agriculture on productive land. As each type of farmer responds differently, the uneven expansion and chaotic appearance of the typical fringe is no surprise. Extensiveness has enough consistency in the Walnut Valley study

area as to make an understanding of how this zone develops an important clarification of the farmer's decision making.

The nature of the urban expansion is determined by at least three basic factors:

- 1) urban and rural land price differences;
- 2) the flexibility offered all land users by modern automobile transportation; and
- 3) the whims and judgements of human beings.

In the present analysis the first is more important. Urban uses pay higher land rents and greatly outcompete agriculture for space. Even when urbanization is expected land is more valuable than rural land alone. Anticipation of development directly affects the land's agricultural use since farmers can no longer plan on long-run terms. As the time approaches for urban uses to succeed, genuine farming increasingly becomes impractical and these farms begin to disappear from the area. While farmers attempt to intensify as costs rise, the dissolving infrastructure reduces operational efficiency and the marginal returns from agriculture decrease the nearer one comes to the city. Urban anticipation increases towards the city and, while land is still farmed, less capitalized marginal farms appear, holding out until a good alternative presents itself. Sub-optimal, disinvested land use replaces intensive patterns. Pseudo-farmers may also hold land in hope of speculative profits. They take jobs in the city and disinvest in agriculture with the feeling that something good will happen, and carry out their activities without the land changing hands. Often, some land is immediately sold to land developer "farmers" and a "satisficing" extensive agriculture follows, or direct conversion to urban use takes its place. Land developer "farmers" make similar decisions; if the land is not ripe for development, what land use pattern will permit some return in the interim without intensive investment? Hence, the fringe can be defined as the zone where urbanization is expected and where farmers begin to disinvest in agriculture (Figure 3). One would expect the type of farmer and purpose of farming to evolve according to the economic conditions encountered (Figure 4).

Urban land values rise toward the city while agricultural values fall, even though productivity remains unchanged, in keeping with the decreased marginal productivity of using the land for agriculture (agriculture is at

FIGURE 3

THE URBAN FRINGE: A DISINVESTMENT ZONE

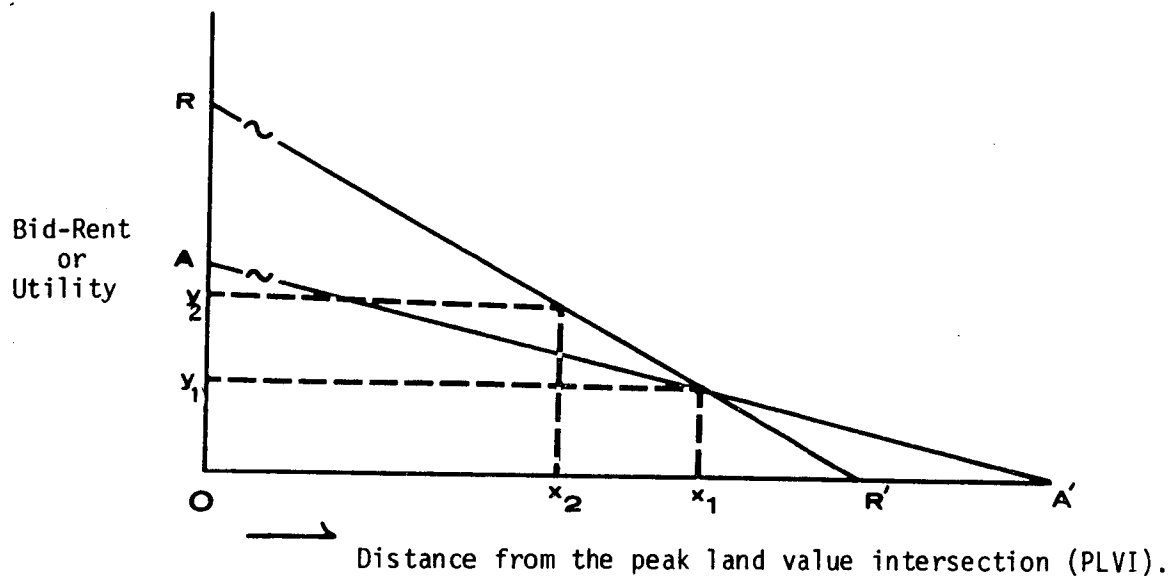

Figure 3: At the intersection of the bid-rent curves of residential (RR') and agricultural land (AA'), both land values are theoretically equal. This intersect (x_1) is not the urban fringe, however, but the outermost point where urban influences add value to agricultural land. Agricultural opportunity costs, speculative profits, plus urban development costs assure that the urban improvement costs are so high that a point closer to the urban core becomes the actual fringe at a given time (x_2), $0y_2-0y_1$ being the various development costs (see Schmid, 1968). Zone $0x_1-0x_2$ is the zone of agricultural disinvestment, or the rural-urban fringe. Values are insufficient in terms of market considerations to make the land "ripe" for urban development. While urban values influence the zone, long-run planning in agriculture becomes unfeasible. If rent is translated into land use, the conformity with a von Thunen scheme still exists.

FIGURE 4
 TYPES OF FARMERS IN THE DISINVESTMENT ZONE

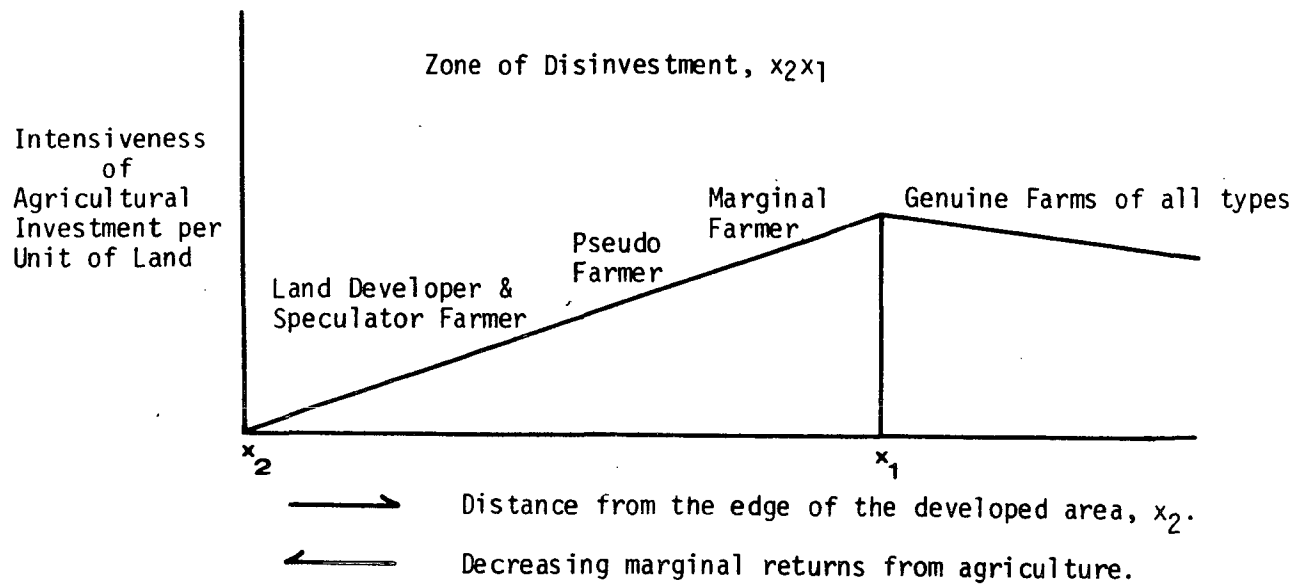

Figure 4: A weeding-out process occurs when urban economic pressures interact with agriculture. Genuine Farmers (Economic Classes I-III) operate until they are forced to relocate. Commercial farms of Economic Classes IV-VI and a few of Class III become Marginal Farms as costs rise, some of which may, for a time, become Pseudo Farms until the owner establishes himself in a new venture. Soon they are sold and agglomerated into Land Developer-Speculator Farms on the immediate fringe, x_2 . Genuine Farmers of all types of farm reestablish themselves beyond the fringe, x_1 , in the normal von Thünen zonal framework.

Source: Adapted from Higbee, 1967.

a disadvantage - theft of produce, complaints, high taxes, the lack of an infrastructure - so much that rural land values or marginal returns imputed to land decrease to a negligible degree (Figure 5). In terms of land use, the pattern is the reverse of a von Thünen scheme. Urban uses are momentarily unfeasible given the costs of developing raw land; agricultural activities cannot plan ahead. The fringe, however, is not static, and an important modification must be made to von Thünen's thesis to make this concept and how it affects decision-making understood.

Sequential Land Use

Von Thünen's static city assumption, a city with unchanged boundaries where transportation cost influences land use, must be modified in most industrialized nations. Transportation innovations revolutionized urban growth processes. Urban influences now precede the built up area and extend far across boundaries into rural areas. Low density environments are created in the city which rely on transportation, wide extensions have been made of low density Sinclair zones on the fringe, and the von Thünen zones have been further removed, particularly adjacent to the transportation link (Sax, 1878; Gregor, 1963). One now assumes that in a dynamic situation a parcel of land on the fringe undergoes successive changes in land use with each period of urban growth. Blumenfeld (1954) and Boyce (1966) compare this change with oscillatory changes in a parcel of water within a wave. The similarity is close. Figure 6 diagrams a precessional wave (backwash) of agricultural land value prior to an inundating flood (not drawn) of urban values. The conversion cycle begins with land use intensification as the inner von Thünen zones migrate outward ahead of the expanding urban periphery. Agricultural values are maximized at the peak of the precessional wave. Disinvestment stages follow because of the threat of urbanization and Sinclair zones are established. Land owner decisions evolve according to the type of farming, position on the fringe, and the rate at which the wave recedes. Rapid urban growth may short-cut the cycle (genuine farmers sell out to developers who build subdivisions - direct conversion); slower growth may permit a long disinvestment stage (pseudo and marginal farming and interim agriculture by the land speculator "farmer"). Very slow growth may permit long-run planning and investment in the typical inner von Thünen zonation; controlled growth would channel this into certain areas. Urban

FIGURE 5

LAND VALUES WITHIN THE DISINVESTMENT ZONE

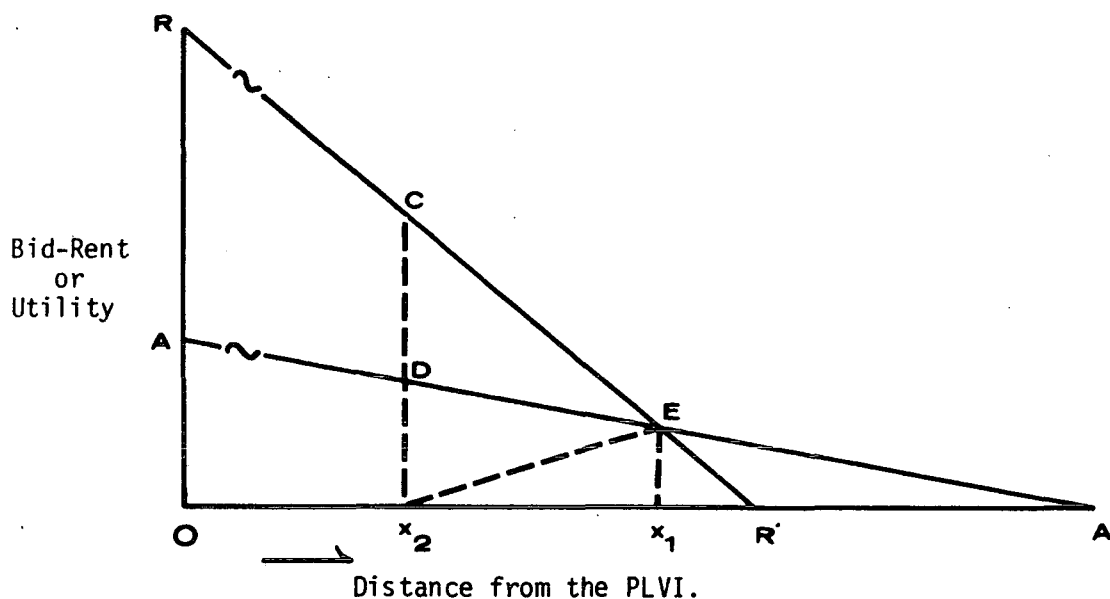

Figure 5: From the fringe (x_2) to the intersection of the residential and agricultural bid-rent curves (x_1), the zone of disinvestment breaks down into three parts: 1) the triangle CDE shows urban speculative values decreasing with distance from the fringe to where they are negligible beyond x_1 ; 2) triangle Dx_2E indicates how agricultural disutility increases toward 0 sufficient to reduce land values to virtually nil in agricultural terms at x_2 ; 3) triangle x_2x_1E is a zone of increasing agricultural values. At point Ox_1 , both uses theoretically bid the same for space, but agriculture prevails in the disinvestment zone due to its lesser capital investment. Beyond x_1 , agriculture takes over without urban influences in a normal von Thünen framework beginning with the most intensive use.

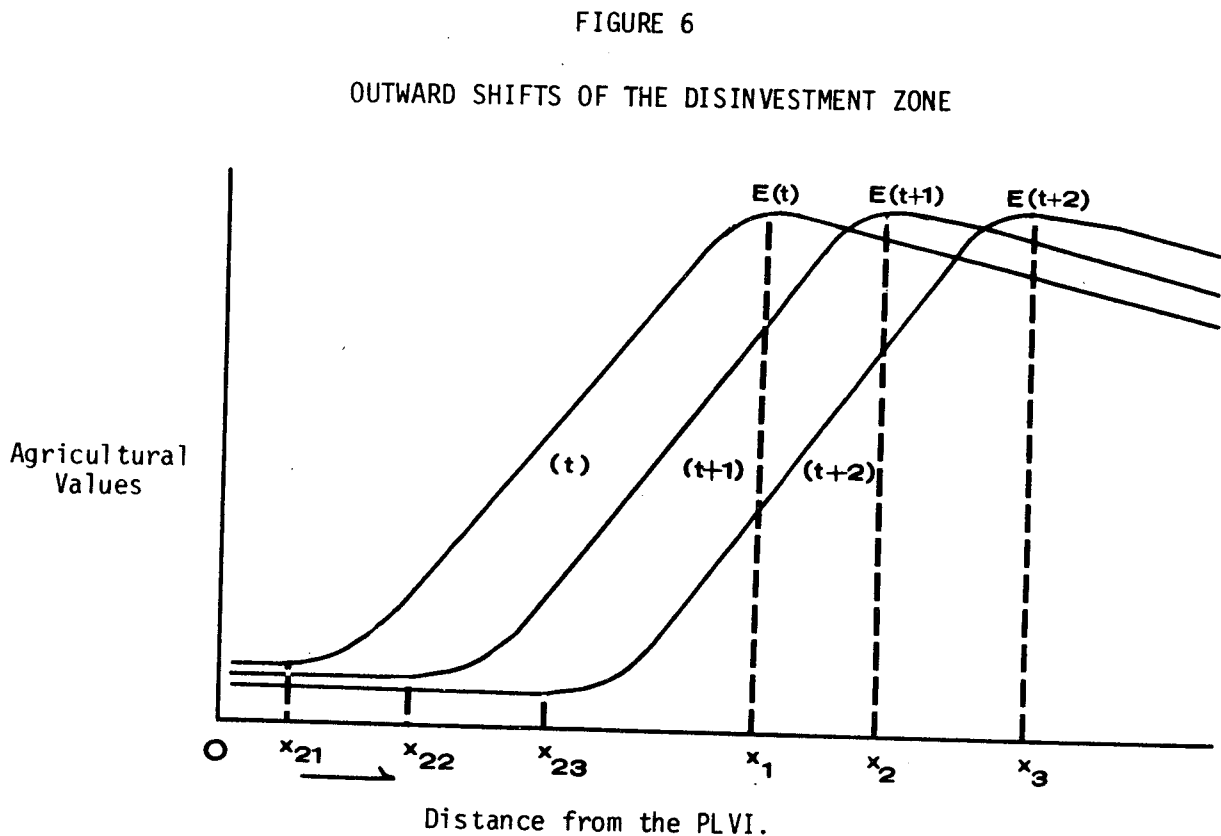

Figure 6: The disinvestment zone, Ox_1-Ox_2 in Figure 5 dissolves into a declining agricultural value curve which shifts outward in time like a precessional wave as urban uses expand. At time (t) agricultural values decline approaching the developed area until value is nil, urban competition and the disadvantages of locating near cities, being the reasons. At time (t), the zone of disinvestment becomes Ox_1-Ox_{21} , land value for agriculture lessens from x_1 to x_{21} , and disinvestment increases. At time (t), intensive land uses of a von Thünen framework develop beyond point x_1 , the apex of agricultural values based on urban proximity at that time. Farther removed, agricultural values would again decline with distance as land uses adjust to market accessibility.

At time (t+1), the zone of disinvestment has shifted to Ox_2-Ox_{22} . Area x_1x_2 now declines in value whereas at time (t), it was highest. The entire value curve from time (t) is lowered. At time (t+2), the zone of disinvestment has become Ox_3-Ox_{23} , and x_1x_2 has declined even farther. Conceivably, x_1x_2 , then x_2x_3 , etc., intensify as urban growth proceeds, and, once intensification reaches its peak, then disinvest.

succession or the completion of the conversion cycle follows when the advancing inundating wave (proportionally higher than the precessional wave owing to the disproportionate land value) overwhelms the disinvestment zone of deflated agricultural values. Hence, the wave theory analog approach fits a fringe situation not only in population terms as the above writers consider it, but also in differences of land value and use.

Timing the Conversion Cycle

In a static situation, the criterion for maximizing profits in allocating land is that the value of the marginal product in all uses should be equal (Shoup, 1968). Land uses should be shifted from low to high value up to the point where the two marginal products are equal. Given that land yields its service through time, the present discounted value of the marginal product of land in all uses should be equal. The real estate term "highest and best use" refers to the development that would justify the highest payment for the site, either as a ground rent or a purchase price provided that there is sufficient competition among the site's potential users (Figure 7).

Capital improvements to land are justified up to the point where the marginal revenue product of an increment in capital investment declines to the extent that it equals the cost of an increment in capital investment in improvement. For example, replanting citrus groves can proceed up to the point where the additional cost is just equal to the discounted value of future returns. In other words, the marginal rate of return on capital investment must equal the interest rate. "Highest and best use" may not be realized while the land "ripens" or awaits the next level of development (if the above investment is not justified) and even in the static case a disinvestment pattern (sub-optimal farming) may develop until changed conditions warrant investment - the situation is no longer static. Timing the development must, of course, recognize the above criterion - the equality of the marginal rate of return and the interest (discount) rate.

In a changing community the optimal time for development may not be the current time. Population growth and redistribution, increased personal income, technological change, etc., will continually alter the demand for the services of real estate in specific locations. Increasing demand

FIGURE 7

DETERMINING THE LAND'S "HIGHEST USE": A STATIC CASE

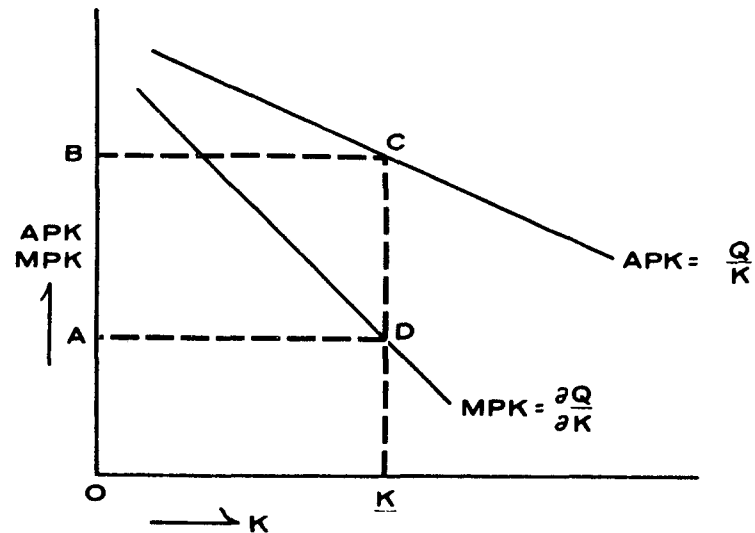

Figure 7: Both the average produce (AP) and marginal product (MP) are a function of the capital input to a site (K). In the following example average and marginal revenue product are calculated less operating and maintenance expenses and the optimal capital input is \bar{K} . The value of the improved site would be $OB\bar{C}\bar{K}$. Subtracting the cost of improvement, $OAD\bar{K}$, from the total site value gives the value of the bare site, $ABCD$, as a residual.

Source: Shoup, 1969.

should bid up both average and marginal product of capital curves in Figure 7, several times. Freeway construction, population growth, and a new infrastructure will justify a more intensive use of the land. When should the land be developed and what is the maximum outlay? Using the same optimality criterion - maximizing the present value of the land's marginal product - a problem is presented in planning the land's use. Once improvements are made into the land, development fixes for some time the services the property will render.

Rising demand conditions necessitates a land planning procedure that times the intensity of development with fluctuations in the rise of demand (highway improvements, sewers, other public and private facilities). Each form of development must be commensurate in marginal revenue product of land discounted to the present. Hence, in a rural-urban fringe situation, residential or higher land values discounted to the present may make land too expensive for agricultural use but not yet ready for urban uses given the cost to develop the land, i.e. bring it into production. Intensive agriculture is feasible only if the rate of return is high enough to repay the improvement costs over the practical life of the improvement. Should the present discounted marginal product of the land equal urban uses, as it does in "urbanized agriculture," agriculture may prevail over more fixed improvements as residences, etc. When intensive agriculture cannot be justified as an interim use, some form of a less intensive or even extensive agriculture may better fit the investment/return horizon while the land "ripens." Conceivably, a sequent occupance of agricultural land uses could evolve - environmental conditions permitting - according to the changes in the interest rate on the marginal product of land discounted to the present. Regional population growth rates would project a demand for residential land that orders agricultural land planning decisions toward one development future in keeping with environmental, carrying cost (taxes), and interim use demand conditions. Accelerated growth changes the rate of discount by which residential use (highest use) is evaluated and the above conditions also must change. Public works projects mean even more changes, and it is reasonable to suppose that when all these economic stimuli are active - population growth, extension of roads and service networks - planning is in a state of flux. Ideally, an agricultural interim use would

absorb those carrying costs until development to a higher use and longer repayment/investment schedule becomes possible - hence, a sequent occupance is possible in the ideal case (the outward migrating zones of intensive agriculture in the von Thünen system). Shoup (1968) bases the optimal date of development on:

- 1) the discount rate applying in the real estate market;
- 2) the property tax rate;
- 3) the earnings of any interim use; and,
- 4) the way in which the highest and best use of the land is expected to change in the future.

From the point of view of the investor, optimal timing recognizes the private marginal product of land. If there are externalities associated with the land's use, the marginal social product may differ considerably, and to some extent these externalities are taken into account by zoning and planning regulations that vigorously attempt to phase land development. When they are not accounted for by the planning framework the optimal timing conditions will differ considerably from socially optimal conditions.

Population growth and local land demand undoubtedly influence the conversion cycle strongest; freeway construction brought demand to the critical stage. Walnut Valley's relative inaccessibility meant that demand was long unsatisfied. Physically the valley was as close to the Los Angeles CBD as the East San Gabriel Valley, served since the early 1950's by the San Bernardino Freeway. Only when the Pomona Freeway was complete could the time-distance compare and the untapped land resource evolve, based on proximity, to its highest use.

THE VALUE OF ACCESSIBILITY

Accessibility increases the locational utility of a place or area by decreasing the time expenditure (cost or effort) in transportation required for the place or area to satisfy its operational needs (those natural or human resource requirements which permit the place or area to fulfill its functional role in a larger system of places and areas, Figure 8.

Figure 8

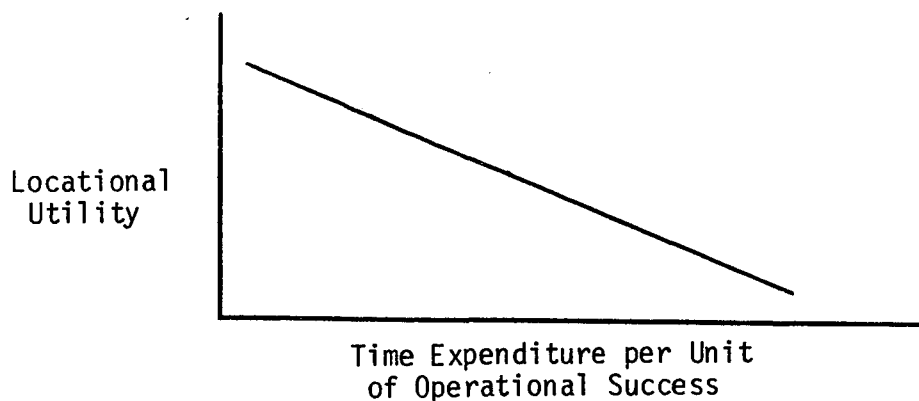

Functions requiring many high cost/high effort trips per unit of time need sites of high locational utility. Land use becomes ordered according to functional competition for locations that are accessible in terms of its transportation needs. Were transportation instantaneous and costless (an isotropic transportation surface), the urban population would spread over all usable spaces none of which would have higher locational utility. Land prices would be reduced to their approximate value in the best alternative use and site advantages or the natural endowment - soil quality, resource value - would establish what use is best. Freeways have this effect. Large areas are opened to use by an already highly mobile population. Intersections of major highway-freeway connectors and terrain features assume high land values.

Suburbanization has followed a series of improvements in mass transportation either in the form of public transit media or efficient means for using the private auto for the journey-to-work. Mobility permitted persons to trade off accessibility for amenities because residential land use demanded less locational utility. It generated fewer high cost trips and was more footloose than commercial and industrial land uses and could easily spread outside the central cores of cities into the suburbs. Commerce and industry require high accessibility and converged on the CBD until this proved limiting. Congestion forced decentralization. Commerce followed residential populations into the suburbs and established new market areas because it was oriented to local markets, more than industry, and took advantage of the mobility of its customers. As better mass transportation media were innovated, greater suburban populations could reach the core and

only then could industry suburbanize effectively. Trucks and good highways made specialized hauling feasible in the 1920's and gave the first impetus to suburbanization in industry. Freeways, in a later period, added to the efficiency of transportation and accelerated the suburban process. Factors accounting for its desire to relocate are well known - lower land prices, sites of a suitable size, lower local taxes, zoning, and other regulations. These differential opportunities are exploited by business depending on the extent to which the level of development of the highway and street system minimized space friction. Industry selected sites that were advantageous to its purposes and located wherever the relative advantage was greatest. Consequently, it also became more specialized with decentralization. Grey (1965), describing on Los Angeles as an urban prototype, says, "the provision of transportation facilities affects and is affected by the location of industry." Which comes first, the decision to relocate industry or the decision to improve transportation? For Walnut Valley it suggests that the chain of events to incorporate, industrialize, and connect areas of this region with the Los Angeles metropolis were highly interrelated.

Questions on Net Benefit

Whether the use of public funds for freeway construction is economically justifiable on broad social grounds depends on the totals of costs and benefits to business and sustained directly by society. Certainly the benefits to some sectors of the economy have been large. Currently there is much concern whether the freeway best serves the transportation needs of all the population and whether the freeway is justifiable on grounds of environmental impact and optimal resource use. There are other social costs raised by the construction of freeways on the urban fringe. Increasing the land supply forms a wide zone of disinvestment and magnifies the accompanying social costs of non-optimal land use - agricultural blight and the problems of suburban sprawl extended over a wide area (Figure 9). Higher transportation charges for agricultural produce shipped to the urban market is another cost.

Accessibility improvement expands the zone of disinvestment and makes it more diffuse. It reshapes the bid-rent curves of residential and agricultural land use by minimizing the importance of locational utility. This

FIGURE 9

ACCESSIBILITY IMPROVEMENT EXPANDS THE ZONE OF DISINVESTMENT

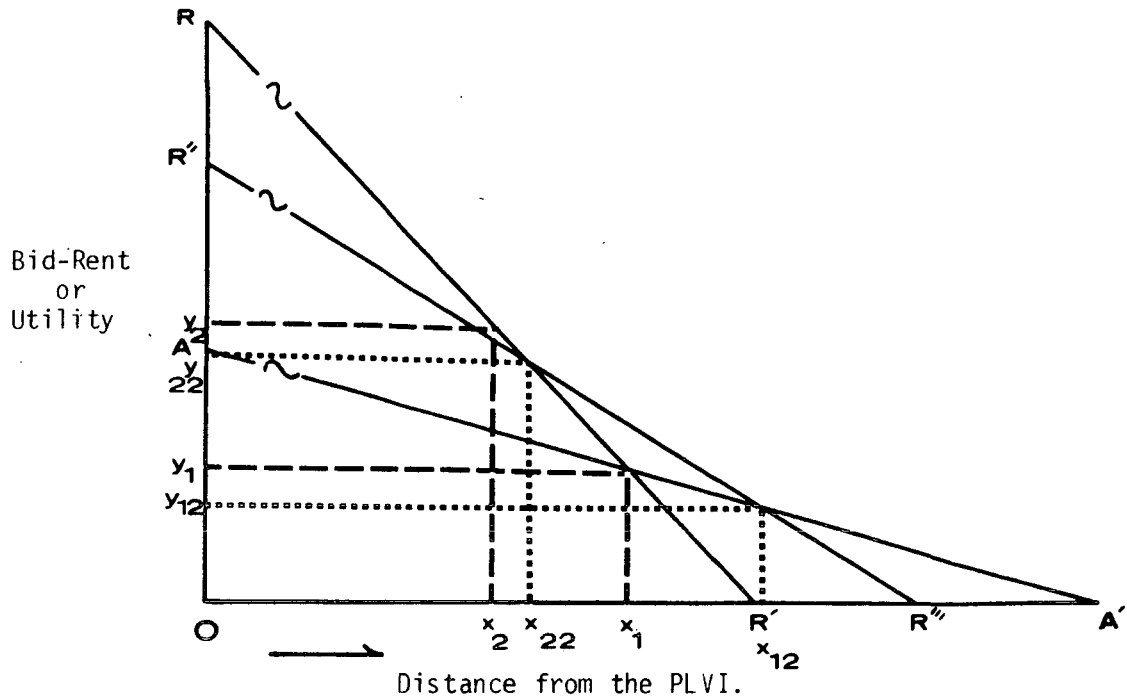

Figure 9: Both agriculture and residential land use profit from improved transportation, but residences profit most due to their greater unit value and demand for locational utility. This bid-rent curve changes perceptibly. Locational utility has a lessening effect on the average land value as places closer to the urban core are reduced in value while the land supply increases. New lands on the fringe are brought into production with a high rate of value gain from improved locational utility. Both effects - locational utility improvement on the fringe and an increased land supply - expand the zone of disinvestment. With land improvement costs unchanged, Oy_2-Oy_1 to $Oy_{22}-Oy_{12}$, the amount of land subject to disinvestment increases from Ox_1-Ox_2 to $Ox_{12}-Ox_{22}$, or subtends more area. The selling price can be reduced (although in public investment projects the question whether such savings are passed on to lot purchasers is not adequately answered). Part of the extended zone lies near the present edge of the disinvestment zone, and the other end has pushed farther into agricultural areas.

raises both bid-rent curves, but particularly the higher residential land use curve, and makes it more concave. When distance friction can be overcome efficiently, large areas come together in space-time and intraregional land use competition focusses on the best sites. Land nearer the urban core benefits less than land on the urban fringe, and the average rent for residential land use is reduced (Wendt, 1957). At the intersection of these curves, the $\bar{R}R^m$ and AA' curves, the unchanged margin between agricultural and speculative land values and development costs remains the same but now subtends more area than before (Figure 9). Roads expand the potentially urban area and subject it to urban pressure and force more landowners to make decisions than otherwise would be done. Given their varied abilities, information, and plans, the result is the chaotic, unorganized, and economically differentiated land use of the fringe.

Residential land use benefitted in terms of time savings and lost in terms of travel costs when mass transportation routes facilitated suburbanization. Where an individual once traded off relative inaccessibility for amenities, the new high speed routes minimized distance friction which saved him time and increased his real income. Freeways permitted him to live farther from the core and still consume the same travel time. Places came together in time-space, but not in distance. If he should relocate along with newer residents attracted to suburbia (perhaps the more common instance because it permits more of what suburbanization initially gave - amenities as space, aesthetic surroundings, less congestion), he spent as much time traveling as before, but raised his total travel cost, i.e. he traveled more miles at the same time cost. Total transportation savings (time and per mile) would be less if he stayed, and likely to be greater when he moved. Accessibility improvement works like an inferior good (Figure 10). As an input price changed (transportation) a substitution effect followed which increased distance from the urban core (Ox_1 to Ox_2). An income effect, generated by the higher cost per trip partially cancels the former effect. As has often been said, the freeway creates more travel, to the greater benefit of those who sell land and auto products than to those who consume each commodity. Freeways would have benefitted the whole population if growth were checked.

FIGURE 10

ACCESSIBILITY (LOCATIONAL UTILITY) AS AN INFERIOR GOOD

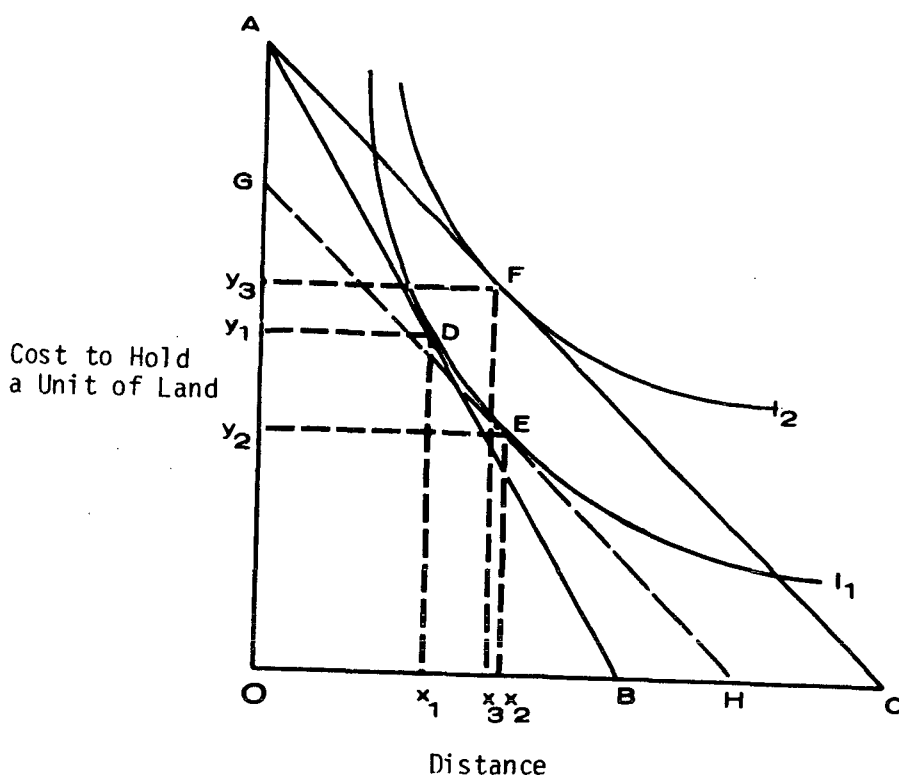

Figure 10: Budget space OAB is used to purchase land in a manner that maximizes satisfaction at that level of income. With land quantity fixed, the location must be adjusted in keeping with the costs for the amount of land needed. Equilibrium is reached at D on indifference curve I_1 . Ox_1 is the distance the individual lies from O; Oy_1 is the cost he pays for the fixed amount of land.

Reducing his costs of land occupancy with a transportation innovation lowers his locational utility at that site, and changes the relative importance of land and location. His real income increases. If we diagram the new price ratio at the old level of income (GH), at equilibrium (E), the land costs (commutation included) decrease and he relocates farther from O. This combination is the substitution effect - a move from x_1 to x_2 , and a drop in land costs from y_1 to y_2 . The income effect should be strongly negative if accessibility is an inferior good, and it appears to be provided that we consider social and hidden consumer costs (higher service rates, inflated land values, higher total cost of transportation, and certain non-tangible costs associated with uniformity of the cultural landscape). These suggest that at the new income level and new price ratio, certain apparent costs at a new equilibrium (F on indifference curve I_2), may deter a move outward (x_2 to x_3 is negative). At the same time, the shift to y_3 indicates that land holding costs have risen. Hence, the individual that appreciates the amenity of suburbanization undoubtedly has paid for it in his other land holding costs.

Freeways extend the urban fringe farther into agricultural areas along those channels the routes occupy. Interstitial areas generally are served by improved freeway-feeder lines at right angles to the main route. Where such a network is provided the transport network is made fairly dense, virtually isotropic as compared to the star-shaped city of Hurd's (1903) time (land use density gradients fell off considerably at right angles to the rail commuter lines). As the city grows, intensive agricultural patterns shift outward fastest along transportation lines, ahead of development and prongs and sectors with agriculture in the interstices are characteristic. The zone of disinvestment is distorted, varying from its narrowest in the interstices to its widest along and ahead of the route.

SINCLAIR ZONATION

Reversals of the land use intensity gradient are justified, theoretically, around the expanding city (Figure 11). Intensive production zones migrate outward with urban growth while extensive zones move inward, both within a larger von Thünen pattern where land value, but not use, maintains a constantly diminishing gradient away from the city. Gregor (1957) recognized that urban areas prejudiced agricultural land beyond the built up area, but Grotewold (1959) was the first to propose this zonation reversal, and Sinclair (1967) has followed with the ring-like model. Best and Gasson (1966) have also added their support to this theory in their study of a trend toward extensiveness near London. They believe that the shift is largely the result of: 1) increasing competition from areas more distant but with otherwise better production facilities; and 2) the loss of casual labor to city jobs by urban fringe farmers (forming of pseudo-farming out of marginal farms?). In the United States, inverted zonation has more to do with the rising cost of real estate nearby cities. There is also the matter of other areas, equally well endowed agriculturally but with good marketing services, that have taken the place of market-oriented agriculture. The initial incentives for genuine farmers to relocate were factor input costs, however, not improved production elsewhere.

Utilizing these notions, a different set of concentric zones (an inverted set) conceivably can form around the expanding American city. Extensive agricultural zones develop on the immediate fringe under the

influence of the infeasibility of capital investment. Intensive agricultural zones of the normal von Thünen land use framework develop outside the zone of disinvestment (Figure 11).

- 1) Zone 1, the edge of the built up area, where land is either changing to urban use, is being subdivided, or is being held by speculators or developers for early development. Some farmers hold out but soon enough they are forced out of production by high urban taxes, zoning practices, or by nuisances associated with locating near urban areas. "Urbanized" agriculture may coexist being as much a commercial or industrial as an agricultural land use.
- 2) Zone 2, the vacant land where urban subdivision is not yet taking place, but where farming, in general, is no longer carried on. There are broad expanses of barren, unused land, owned by speculators, or farmers who intend to sell at the most profitable time. Since farmers have no guarantee of the time of development, they often do not farm at all. Those activities which take place generally are short-lived and extensive, as where land is leased to some farmer in a more distant zone for the grazing of animals, or crops of hay are grown with the primary object of keeping down weeds, as laws often require.
- 3) Zone 3, the field crop and grazing use zone where transitory agriculture is carried on with the anticipation of urbanization at some future date. The farmer does not wish to invest capital and the marketing facilities have generally moved out at some much earlier date. His marketing mechanism is abbreviated and his activities hampered. Farming, under the circumstances becomes extensive, land is leased out to outsiders who grow wheat, or other cover crops and the general trend is to less productivity per acre, poorly maintained soil fertility and marked disinvestment in agriculture.
- 4) Zone 4, the dairying and field crop zone that is beyond the influence of future urbanization. It remains within the influence of the urban markets, but in most cases it does not realize itself subject to urbanizing influences. Beyond Zone 4, zones farther removed take on von Thünen characteristics.

Variations in regional farming patterns, urban growth rates and directions, response to influences, disturb the applicability of these notions so that the ideal may never be realized. The assumptions of uniformity and stability are never found. These variables do not, however, affect the validity of the principles involved in the theory. The specific makeup of the model applies closely to the pattern in Walnut Valley as well as in examples Sinclair (1967) investigated. Gottman's (1961) work indicates similar patterns involving anticipation but found other uses and part-time farming

FIGURE 11
ZONATION WITHIN THE DISINVESTMENT ZONE

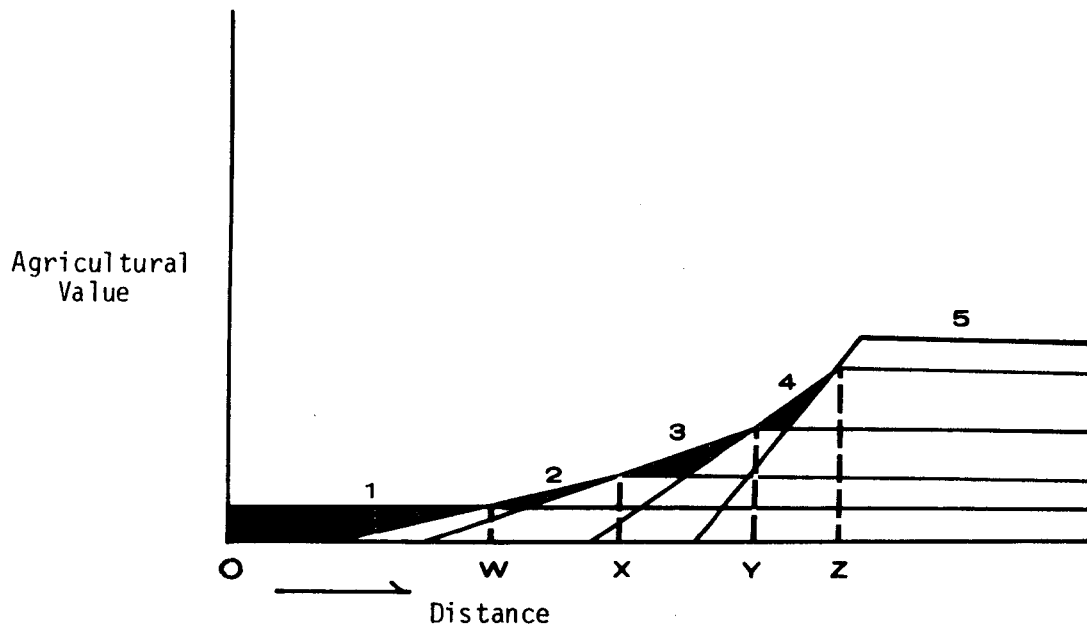

Figure 11: Figure 11 diagrams the relationship of value for agriculture and distance from the urban area for competing land uses. As O , the urbanized area is approached, the value of carrying on each of the particular types of agriculture decreases. The steepness of each bid-rent curve is proportional to the intensity of agricultural investment. Intercepts at W , X , Y , and Z indicate changes in land use.

Source: Sinclair, 1967.

as substitutes. These examples suggest poorer farming practices as the result of advancing urbanization. Fewer livestock were kept. Less attention was paid to good cultural and soil conservation practices. Cash cropping, rather than regular fertility-building rotation, was common. Mining the soil was apparently related to the imminence of planning for non-farm uses. Associated with the pattern is part-time farming.

Lessinger's (1956) analysis of agriculture in the San Jose area found that the age and bearing conditions of fruit orchards in different zones around the city, i.e. the deterioration, was closely related to the degree of anticipation of urban demand as reflected in land prices. Allowing the trees to deteriorate is, essentially a less intensive manner of using the land. Krueger (1959) found a similar situation in the Niagara fruit belt of Ontario. However, Gregor (1963) indicates that less vacant land is the rule for Californian cities than for other American cities. Small, not large vegetable farmers form a market gardening belt. These short-term investment proposals (intensification in lieu) - quick profiting vegetable farms - do not disturb the concepts above, which are long term proposals. Small vegetable farms were common the the Puente Valley to the west until smog forced many out of production. Crop selections of smog tolerant leafy vegetables have permitted their raising in Walnut Valley. Very obviously the patterns develop where intensive agriculture surrounds the city and is encroached upon by urbanizing influences and do not appear in areas without substantial agriculture or in areas with agricultural forms already extensive, e.g. cash grain farming. These simpler patterns permit land use conversion to proceed unimpeded. But where von Thünen-like agricultural zonation exists, disinvestment zonation is likely to form. In total, many studies indicate that the frame of reference in this report can be applied to non-urban land near many urban centers.

Other approaches besides examining land use can predict land use conversion. Kaiser et al. (1967) predicts the behavior of predevelopment land owners on the urban fringe by using landowner and property information in public records or planner's files. For example, they suggest using data on how long the land was held prior to the study period, whether or not the owner lived on the land, whether or not the owner was retired, whether the ownership was single or joint, the assessed value of the land, and the

amount of urban development surrounding the parcel. Essentially, they are suggesting what Higbee (1967) also recommended: using non-published U.S. Agricultural Census information for use in recognizing the different types of farmers and their purposes.

CHAPTER V

SUMMARY AND CONCLUSIONS

The spatial structure of American cities has changed rapidly due to a shift from a space intensive to a space extensive technology supported by private automobiles. In addition, a change in social and economic requirements for space and location has occurred with rising real income, increased personal and functional mobility and changing tastes. Both the means and the incentive exist for changing spatial relationships. Many urban problems are owed to these changes. One of concern is suburban sprawl and a greater dispersion of population and activities.

Quantity replaces quality in suburbia. Extensive land use patterns replace intensive ones, yet, society has paid for quality in the process. Extensive urban economic patterns (land uses) were sustained by major investments into the service systems. More linear miles of power lines, water and sewage conduits, and miles of high capacity roads express how vast are the amounts of social capital tied up in low density land use environments. Subjective social costs are also large, e.g. the social, economic, and aesthetic uniformity of the cultural landscape.

An extensive literature treats suburbanization's many costs. Emphases are changing, however. Increasingly, attention centers on methods to control urban growth directly or indirectly, as the forming of parks and agricultural land preserves have done (Chapin, 1963). Little attention has been given to examining rural-urban conversion processes and the way they suggest means for controlling urban growth.

CONNECTIONS WITH THE NATURE OF URBAN INVESTMENT

In part, the incentive to suburbanize stems from the nature of urban investment - a basic conflict between fixed real estate resources and mobile social and economic demands. Once a structure is constructed it is generally uneconomic to replace it with anything other than a more intensive use. Aging makes the structure less desirable and less likely to pay a land rent as time passes; soon it becomes functionally obsolete. In economic terms, the alternative is net disinvestment (Wingo, 1966), or, reducing the factor of production inputs until an intensive use is warranted (in the agricultural

case, relatively less inertia permits production capacities to be transferred from one area to another). Since replacement of older housing is unfeasible in the city center, new housing is forced to the periphery.¹ The result is that with the passing of time the character and distribution of the building stock increasingly become out-of-phase with the demands for physical space. Firey (1946) recognized the similarity between the "transition zone" of a Burgess model (1925), and the urban fringe. Both areas are subject to mobile social and economic demands as dissimilar land uses expand: the CBD functions reach into residential areas of earlier growth phases; the total urban-area encroaches on the agricultural fringe. In both zones, it is uneconomic to replace an existing land use with anything but a more intensive use. Net disinvestment is the only alternative until the land "ripens" for development. Interim uses may be found and, for this reason, continuous land use change is the norm for each zone.

CHARACTERISTICS OF NET DISINVESTMENT

Net disinvestment may occur in several forms. Bourne (1967) found that within the inner transition zone, change in size, type, and the replacement of structures were steps in the conversion cycle of one urban use to another. Factor disinvestment characterizes the first two stages but not the latter one. Rural-urban conversion cycles develop similarly, but with two exceptions: the greater ease in manipulating factors of production creates several stages in the cycle (rural land owners change in size by intensifying without having to disinvest); and, disinvestment (two types) is one distinct stage in the conversion cycle, not a general trend prior to replacement or succession. Furthermore, there are examples of the direct conversion of agriculture to urban uses without intensification or disinvestment. Some clarification of these terms seems an appropriate summary (Figure 12).

Timing the rural-urban land use conversion and selecting an appropriate intermediate process depends on whether economic conditions are static or

¹Urban investment consumes land in a "pioneer" spirit (Schmid, 1968). In terms of capitalizing investments, exploited resource sites are abandoned while shifts are made to more productive sites. New development is preferred to rehabilitating defunct uses. From an urban point of view, the most valuable resources for future expansion are the nearby graded farmlands and developed water resources.

FIGURE 12

FLOW DIAGRAM: THE RURAL-URBAN LAND USE
CONVERSION PROCESSES*
(no scale)

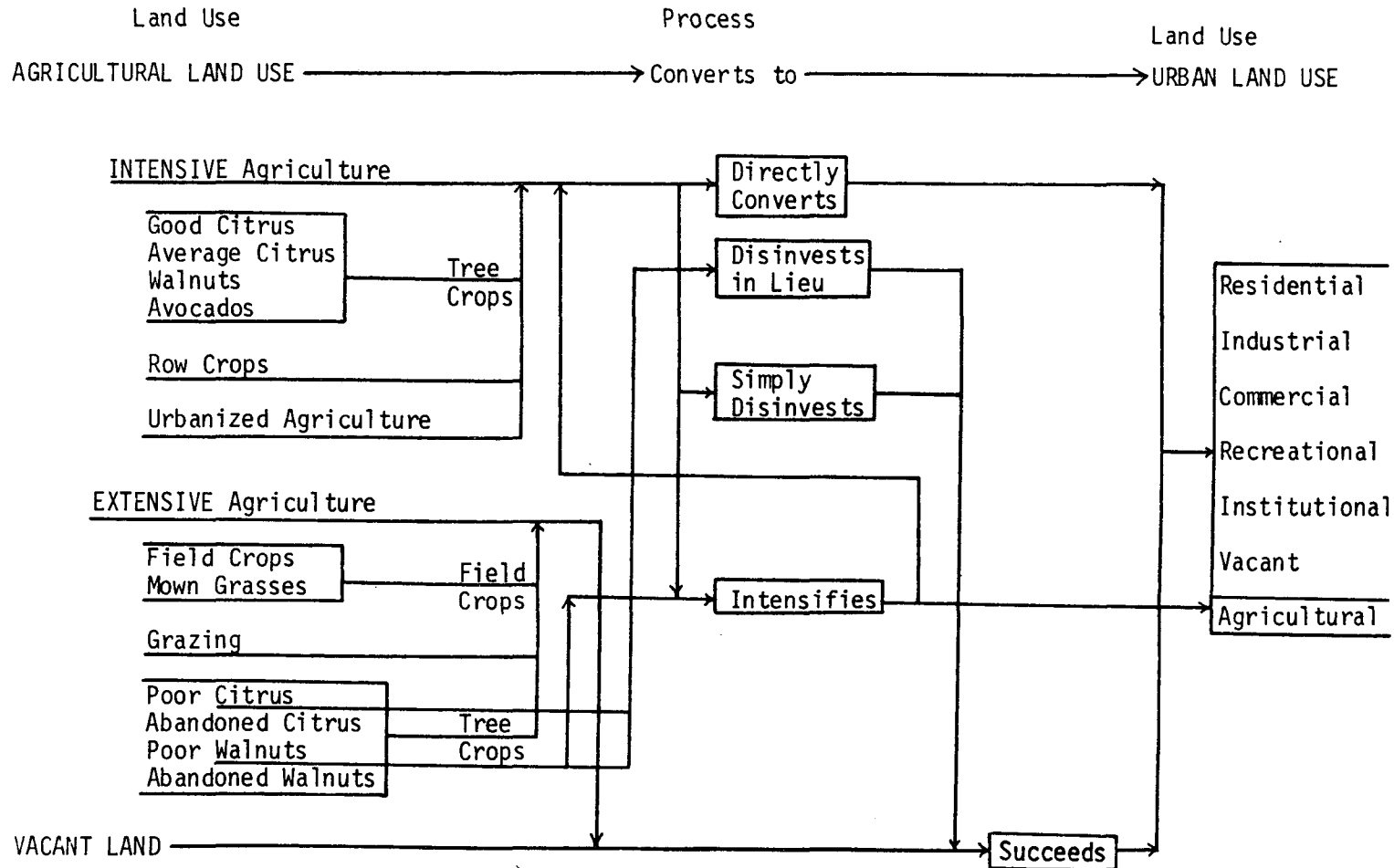

Note: The term succession could properly refer to any land use change or series of changes that preceded a higher use. In this application it is limited in use to the event where a disinvested or already extensive land use passed to an urban use. Land use conversion refers to the total event of change.

dynamic. The freeway announcement, the incorporation of the City of Industry, and the freeway construction periods were dynamic influences for Walnut Valley. In the lag between these events and in the current economic slump, conditions were closer to the static case.

When the optimal development time may not coincide with the present, as in the dynamic case, separate interim uses whose marginal products of capital investment equal and surpass the cost of an increment in capital investment are needed at each inflection of the upward rising average and marginal product of capital curves of the land. Discrete levels in the rise of these curves, if they can be defined, must be matched with agricultural land uses of increasing intensity commensurate with the criterion of investment cost above. Short of the ideal case, where environmental, market, or other conditions do not allow increasingly intensive cropping, and where growth places all agricultural plans in a state of flux, disinvestment is the only alternative land use.

There were two five-year periods of accelerated urban development, 1953-58 and 1960-65, which were correlated with freeway planning, construction, and incorporation activity. Intensification of agricultural land uses was a planning procedure used in this period which accounted for some expansions of dairies and feed lots, and conversions of extensive to intensive agriculture (8.9 percent of all land use change transactions, Table 12). Intensification of urban agricultural land uses is an advisable strategy given their ability to compete with urban uses and the locational advantages of these enterprises warrants long-term investment.

Direct conversion seems contrary to reason but not to the principles of optimal development timing. Agricultural returns were high, but the discount rate in the real estate market had just steepened with this public works project and political activity announced, particularly when the freeway was in the construction stage, and it was higher yet. Some land owners realized a small windfall gain by directly converting to urban uses.

Land used in the conversion processes illustrates timing decisions. Tendencies for urban uses to succeed on land that was already cleared are obvious in the light of probable market prices for cleared versus uncleared land. Land owners with producing acreage directly converted if the selling price could cover agricultural opportunity costs - whatever future returns

were expected from continued agriculture - and the raw land would cost a developer more than if the crop were deteriorated. Only in the "boom" periods would direct conversion be likely. If the land owner had already cleared the land, development could begin immediately and there would also be less expectation of future agricultural income in the selling price. It was a bonus to developers to attract them to purchasing land.

Other land owners may have wished to do similarly, but the addition of such a large supply of land could not be absorbed at once. They chose to enhance development potential and absorbed a land clearance cost to change deteriorated, poor, and in some cases good tree crop acreage into field and row crop uses. They disinvested in lieu of continued maintenance. "Investment haciendas," formed of much walnut acreage in the City of Industry, and many small growers alike adopted extensive agricultural practices. Reinvestment in citrus culture was unwise because the long-run planning that was necessary could not be justified by the rate of return as an interim crop. Taxes were rising as were expectations of developing the land according to its highest use. Construction of the freeway would almost certainly steepen the discount rate again and make greater urban development imminent. Low intensity, extensive agriculture became the planning choice because it minimized capital investment in this state of flux and the land could be prepared for urban use almost immediately.

Disinvestment planning served those land owners who either could not afford clearance costs or were remote from the fringe and unlikely to realize any demand for their property in the near future. Declining citrus always produced better than barley and nothing could be accomplished by land clearance if sales were not in the offing. Lost interim use returns would make a barley succession premature. There might be a better time for changing the land use with completion of the freeway soon to follow and the possibility of additional windfall gains when the discount rate steepens again.

Behavior patterns of predevelopment land owners have many consistencies, given the economic conditions, and it is no surprise to see the patterns repeated from one study period to another. They seem basically rational as much as can be inferred from the data. The type of farmer also bears on the evolutionary process. Land developer and speculator farms would tend to use

disinvestment in lieu planning, and this is suggested by the extensive agricultural land uses on land zoned for industry. The preference toward barley farming, however, in lieu of row crops, many of which are smog susceptible, and replanted citrus and walnuts, seems easily explained. Agriculture is practical as a tax loss operation while the land remains ready to develop. In all likelihood, genuine farmers (agricultural enterprises - "urban agriculture") are now few owing to the strict selection processes applied to agricultural land uses. There were more genuine farms earlier in the settlement history when the land was subdivided into small residential farms. Some have successfully relocated, while most became marginal farms when they lacked any alternative to expensive replanting and had to disinvest when walnuts and citrus declined. In all probability most became pseudo farmers and held land for speculative purposes or sold out to the land speculator and developer "farmer." Some of the farmers found employment in other industries and some, being migrants akin to "suitcase farmers," tend fields in widely scattered locations. Hence, both marginal and pseudo farms may still remain in Walnut Valley although data are insufficient as to determine economic classes.

CONTROLS ON URBAN GROWTH

Externalities associated with the private land owner's timing decisions are controlled somewhat by zoning plans of the respective jurisdictions, e.g. housing quality is regulated by these methods. Lot size minima are 5,000 square feet or larger per single family dwelling unit to assure proper spacing; this also assures that the quality (cost) would be reasonably high. But this is questionable, because NAHB data for 1964, developed by Schmid (1968), show that an average lot in the Los Angeles area (2.6 lots per gross acre) would cost \$9,855. His rule of thumb (lot price equals approximately 20 percent of the total property value) means that the total property value for the lot and house would average \$50,000. Large lot, residential agriculture zoning (2.6 lots per net acre, after 25 percent for streets is deducted, leaves approximately 12,300 foot square lots) is one way of assuring high quality development. Clawson (1967) says, "One should judge a land colonization or development process not only in terms of its suitability for the conditions of the day, but also in terms of its probable

adaptability to meet the changed conditions of tomorrow." One questions whether the extensive single family residential use pattern that requires costly land is the "highest" use. Schmid's rule of thumb makes housing prohibitively expensive, and if developers want a "package" that will sell, they are forced to cut minimum sized lots and crowd the setbacks with a large building that creates the impression of inner spaciousness when exterior spaciousness would be economically impossible without minimizing construction quality. It would be difficult to offer both and maintain quality and the lot space buyers desire.

Besides zoning, public investments and loans, taxation, the power of eminent domain, and the public purchase of easements help shape urban expansion. Most important, however, is the land market. Land closer to the CBD is preferred over land farther out, but it is higher priced relative to land on the fringe. Buyers continually make decisions on the basis of relative preferences and relative costs, and will often substitute cheaper for more expensive land. Costly redevelopment in the central city is avoided in preference for newer building on distant land and scatteration begins.

Added to the basic problem of uneven development is the difference in the holding capacity of land owners owing to varying capital positions, discount rates, and tax considerations. Land speculation is encouraged by imperfections in the market. When windfall gains result from a major public works project, rather than the market adjusting to the new supply of land and reducing overall prices, overpricing results on the new land and land owners who held on longest benefit most. Owners of smaller parcels are less likely to withstand rising carrying costs and are forced out of production earlier.

Agriculture on the fringe deserves support not necessarily for its intrinsic benefits but more in terms of increasing the efficiency of the transition of land. Allocative decisions should have less to do with directing urban growth to be least offensive to agriculture but should largely be toward seeking better patterns of urban development. Needless to say, phasing development to control growth and the extension of urban services in regular increments, is not practiced (California has state law provisions for forming special districts, a device many fringe areas employ to satisfy needs before services are extended from the built-up area).

Hence, a determination of private land owner decisions in the market that involve agriculture are important to a public policy formation that seeks to direct and regulate urban growth.

APPLICATIONS FOR REMOTE SENSING METHODS

Rural-urban land use change is the most dynamic activity in growing urban areas. Extensive areas are converted to low density urban environments and others lie waiting for conversion to urban uses. This major change in use follows a systematic pattern that reflects a land owner's decision-making processes in different economic situations. These sequences point to the character, direction, rate, and timing of urban development, and they are observable by synoptic remotely sensed imagery at a relatively low cost. By comparing subsequent photographs, changed parcels can easily be identified and a current land use map and table can be maintained without difficulty. With other sources as references, assessor's data or Census of Agriculture tapes, individual ownerships are recognizable. One can closely monitor the evolving urban fringe and can approach the prediction of land use change before formal procedures are initiated.

Coverage must be periodic and complete, and there are serious disadvantages when it is not. One has to assume that trends are continuous between remote sensing surveys. For example, direct conversion in the 1953-58 and 1960-65 periods may have involved several years of disinvestment planning before urban use succeeded. Five year spans may be sufficient for intraurban areas where the inertia of the building stock restrains change. Even two years is minimal on the fringe because of the length of the short-run agricultural planning cycle. Each area may well have a unique expression of land use change, the discerning of which becomes difficult if one does not have regular coverage. For best results, monitoring should be performed synoptically, every two years or oftener, at the same season, and at scales large enough (1:24,000, the same as the USGS 7 1/2 minute topographic series, is workable in the United States and permits data to be transferred to the base map with ease) to recognize small parcel land uses (five acres; 2.02 hectares). Color transparencies, in infrared or normal color, permit the superimposing of subsequent photographs. Color infrared has an additional advantage in that the recognition of qualitative differences in

cropping patterns and crop identification can be done better. Black and white format, however, is sufficient and, in all probability, will be all that is available for the early history of change. Radar and thermal infrared imagery were not examined but seem to have many of the same potentials.

Walnut Valley may be unique and this poses additional problems. Sinclair (1967) zonation develops within and requires an intensive or market-oriented agricultural fringe of the von Thünen sort. What kind of disinvestment stage forms in non-agricultural areas? Are there different characteristics in other agricultural areas? Are there any preurban land uses - types of business, trailer parks, recreational land use - that parallel stages in the agricultural conversion cycle? What factors influence the conversion rate, i.e. land owner timing decisions? If there are land use manifestations of disinvestment planning, remotely sensed imagery is adequate to recognize these patterns.

There is no question that aerial photography is the most useful remote sensing tool for urban planners. All too often, planners use aerial photographs only to view inaccessible areas or to serve as illustrations, not to serve the urban research purposes for which they are most able. All organisms, cities included, undergo change in their lifetimes. Land use information describes only the static and not the dynamic case. If tedious methods are used to map land use, planners will make few land use maps, and their uses will be primarily illustrative and/or historical. Two static land use maps compared not only record change but also alert us to evolving regional economic patterns. This report suggests a method to map land use inexpensively, shows how several maps denote change and how change represents complex economic patterns re-establishing themselves, and points a way toward a better planning of the urban fringe.

REFERENCES

- Best, R. H. and R. M. Gasson (1966), The Changing Location of Intensive Crops. London: Wye College, University of London, Department of Agricultural Economics.
- Bolton, H. E., ed., (1966), Historical Memoirs of New California. Translated into English from the manuscript by Fray Francisco Palou in the Archives of Mexico. New York: Russell and Russell.
- Bowden, Leonard W. and D. Goehring (1970), Remote Sensing in County Planning: A Case History from Los Angeles County, Technical Report 69-7, USDI Contract 14-08-0001-12009.
- Bourne, Larry S. (1967), Private Redevelopment of the Central City. Chicago: University of Chicago Research Paper No. 112.
- Boyce, R. R. (1966), "The Edge of the Metropolis: A Wave Theory Analog Approach," British Columbia Geographical Series, 7, 31-40.
- Blumenfeld, H. (1954), "The Tidal Wave of Metropolitan Expansion," Journal of the American Institute of Planners, 20, 1, 3-14.
- Burgess, E. W. (1925), "Growth of the City," in The City, Chapter 2, R. E. Park, E. W. Burgess, and R. D. McKenzie (eds.). Chicago: The University of Chicago Press, 47-62.
- Chapin, F. S., Jr. (1963), "Taking Stock of Techniques for Shaping Urban Growth," Journal of the American Institute of Planners, 29, 76-87.
- City of Industry (1971), General Information on Industry, California. City of Industry: Industry Manufacturers Council.
- Clawson, M. (1960), "Suburban Development Districts," Journal of the American Institute of Planners, 26.
- _____ (1968), "Preface," in A. A. Schmid (1968), Converting Land from Rural to Urban Uses. Baltimore: Research for the Future, Inc, The Johns Hopkins Press.
- Fielding, G. J. (1962), "Dairying in Cities Designed to Keep People Out," Professional Geographer, 14, 1, 12-17.
- _____ (1964), "The Los Angeles Milkshed: A Study of the Political Factor in Agriculture," Geographical Review, 54, 1-12.
- Firey, Walter (1946), "Ecological Considerations in Planning for Rurban Fringes," American Sociological Review, 11, 411-423.
- Fisher, E. M. and R. M. Fisher (1954), Urban Real Estate. New York: Henry Holt & Co.
- Garrison, W. L. and D. F. Marble (1957), "The Spatial Structure of Agricultural Activities," Annals of the Association of American Geographers, 47, 2, 134-144.

- Gottman, J. (1961), Megalopolis: The Urbanized Northeastern Seaboard of the United States. New York: The Twentieth Century Fund.
- Gregor, H. F. (1957), "Urban Pressures on California Land," Land Economics, 33, 311-325.
- _____ (1963), "Urbanization of Southern California Agriculture," Tijdschrift voor Economische en Sociale Geografie, 54, 273-278.
- _____ (1970), Geography of Agriculture: Themes in Research. Englewood Cliffs: Prentice-Hall, Foundations of Economic Geography Series.
- Grey, A. L., Jr., (1959), "Los Angeles: Urban Prototype," Land Economics, 35, 232-242.
- Grigsby, W. C. (1963), Housing Markets and Public Policy. Philadelphia: University of Pennsylvania Press.
- Grotewold, Andreas (1959), "Von Thunen in Retrospect," Economic Geography, 35, 3, 346-355.
- Helbock, R. W. (1968), "New Towns in the United States," Professional Geographer, 20, 4, 242-246.
- Higbee, Edward (1967), "Agricultural Land on the Urban Fringe," in Metropolis on the Move: Geographers Look at Urban Sprawl. New York: John Wiley & Sons, 57-66.
- Hoyt, Homer (1960), "Changing Patterns of Land Values," Land Economics, 36, 2, 109-117.
- Hurd, R. M. (1903), Principles of City Land Values. New York: The Record and Guide.
- Jacobson, J. S. and A. C. Hill, eds., (1970), Recognition of Air Pollution Injury to Vegetation. Pittsburgh: Air Pollution Control Association.
- Janelle, D. G. (1969), "Spatial Organization: A Model and Concept," Annals of the Association of American Geographers, 59, 2, 348-364.
- Kaiser, E. J., Ronald W. Massie, Shirley F. Weiss and J. E. Smith (1968), "Predicting the Behavior of Predevelopment Landowners on the Urban Fringe," Journal of the American Institute of Planners, 34, 5, 328-333.
- Kemler, J. H. (1940), "Railway Entrances and Exits to Los Angeles," Economic Geography, 16, 312-314.
- Krueger, R. (1959), "The Disappearing Niagara Fruit Belt," Canadian Geographical Journal, 58, 102-114.

- Lessinger, Jack (1956), "The Determination of Land Use in Rural Urban Transition Area." Unpublished Ph.D. Dissertation, Department of Agricultural Economics, University of California, Berkeley.
- Los Angeles County (1966), Zoning Ordinance No. 1494 (1927). Los Angeles: Central Duplicating Bureau.
- Los Angeles County, Agricultural Commissioner (1971), Annual Reports, 1938-1970. Los Angeles: The Central Duplicating Bureau (mimeographed).
- Los Angeles County, Regional Planning Commission (1955), Master Area Plan for the East San Gabriel Valley. Los Angeles: Central Duplicating Bureau.
- Los Angeles County (1966), General Plan for the Rowland Heights Community. Los Angeles: The Central Duplicating Bureau.
- Nevins, J. A. (1951), "The Puente Area: A Study of Changing Agricultural Land Use." Unpublished M.A. Thesis, Department of Geography, University of California, Los Angeles.
- Ray, W. W. (1970), The Rural-Urban Fringe. Monticello: Council of Planning Librarians, Exchange Bibliography No. 133.
- Roterus, V. and I. H. Hughes, Jr. (1948), "Governmental Problems of Fringe Areas," Public Management, 30, 94-97.
- Sax, E. (1878), Die Verkehrsmittel in Volks- und Staatswirtschaft. Vienna: Hölder.
- Schmid, A. A. (1968), Converting Land from Rural to Urban Uses. Baltimore: Research for the Future, Inc., The Johns Hopkins Press.
- Sermonti, E. (1968), "Agriculture in Areas of Urban Expansion," Journal of the Town Planning Institute, 54, 15-17.
- Shoup, D. C. (1969), "The Optimal Timing of Urban Land Development," Papers of the Regional Science Association, 25, 33-44.
- Simon, H. A. (1957), Models of Man. New York: John Wiley & Sons, Inc.
- Sinclair, R. (1967), "Von Thunen and Urban Sprawl," Annals of the Association of American Geographers, 57, 72-87.
- Snyder, J. H. (1966), "A New Program for Agricultural Land Use Stabilization: The California Land Conservation Act of 1965," Land Economics, 42, 1, 29-42.
- Thompson, K. (1961), "Location and Relocation of a Tree Crop - English Walnuts in California," Economic Geography, 37, 133,149.

Von Thünen, J. H. (1826), Der Isolierte Staat in Beziehung auf Landwirtschaft und Nationalökonomie. Hamburg: Perthes.

Wingo, L. (1966), "Urban Renewal: A Strategy for Information and Analysis," Journal of the American Institute of Planners, 32, 3, 143-154.

Wendt, P. (1957), "Theory of Urban Land Values," Land Economics, 33, 2, 228-240.

ACKNOWLEDGEMENTS

This study has been carried out under the support of Project THEMIS, Office of Naval Research, Geography Programs Branch, Contract No. N00014-69-A-0200-5001, and the National Aeronautical and Space Administration (NASA), Grant No. NGL 05-003-404. Aerial photography came from several sources, public and private. United States Department of Agriculture, Soil Conservation Service photography was used for 1953 and 1965. The Los Angeles County, Regional Planning Commission provided the 1969 color infrared imagery, and the National Aeronautics and Space Administration (Mission 164) materials were used for 1971. Geotronics Incorporated of Long Beach, California supplied photography for 1958 and 1960.

A central issue in this research in urban dynamics - the character of land use change suggests evolving economic patterns - was advanced in many conversations with Mr. Jene McKnight, Regional Planner, with the Los Angeles County Regional Planning Commission. The aid of this individual I would specifically like to acknowledge. Any fault for error of omission or commission, however, rests solely with the author.

Special acknowledgements are given to Miss Mary Ann St. Clair for cartographic assistance, Mrs. Kay White, Department secretary, for typing the manuscript, Mr. Robert Hicks for photographic aid, and to Dr. Leonard W. Bowden, Principal Investigator and Mr. William G. Brooner, Research Specialist, who provided support and guidance throughout the study.

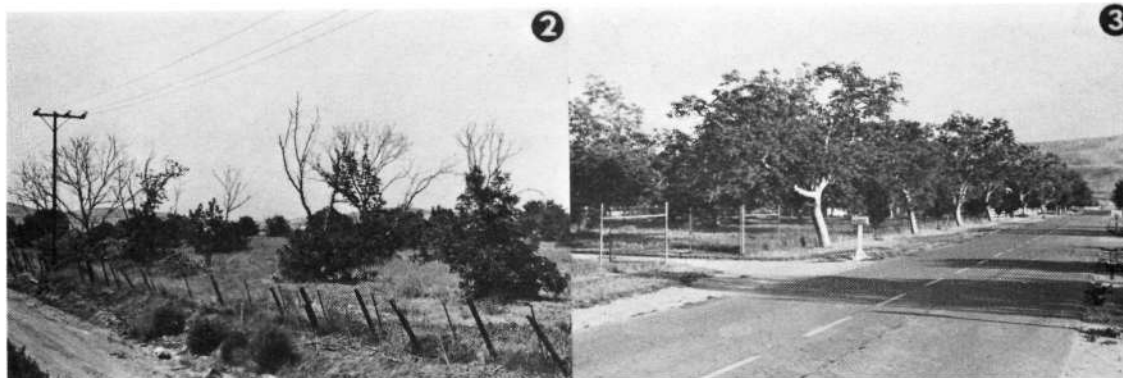
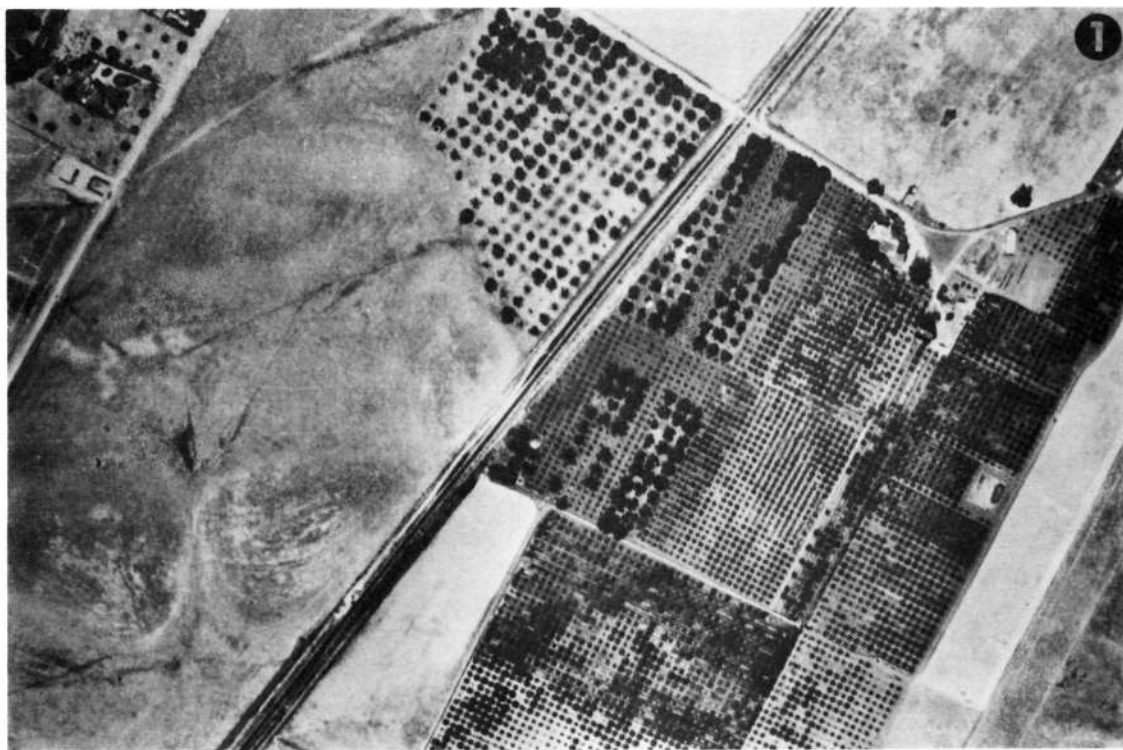

APPENDIX A

- Plate 1: 1960 aerial photograph of mixed arboreal culture shows walnuts (larger crowns) in a declining state, except for individual trees. Citrus is classified as poor, judged primarily on irregular crown cover (City of Industry, California).
- Plate 2: 1970-71 photographs at ground level record what remains of these patterns today. Walnuts grow without maintenance (City of Industry, California).
- Plate 3: Some walnut groves procure and a minimal acreage remains, particularly in residential areas (Rowland Heights, California).

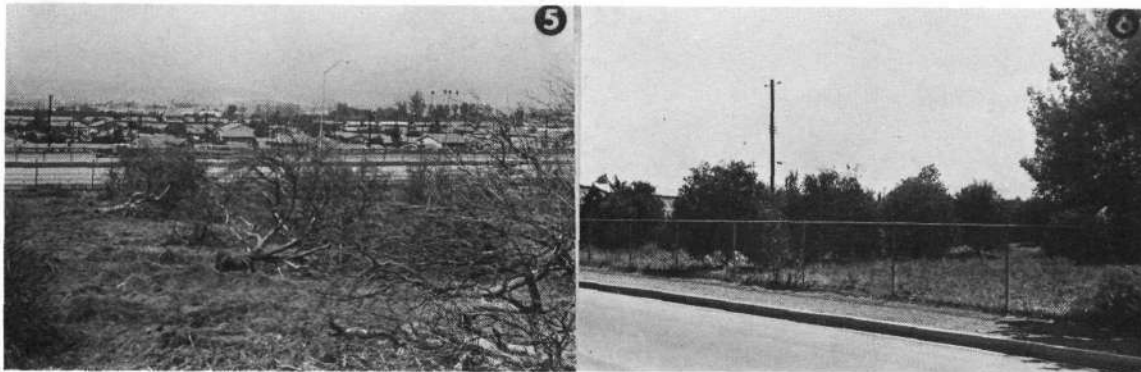
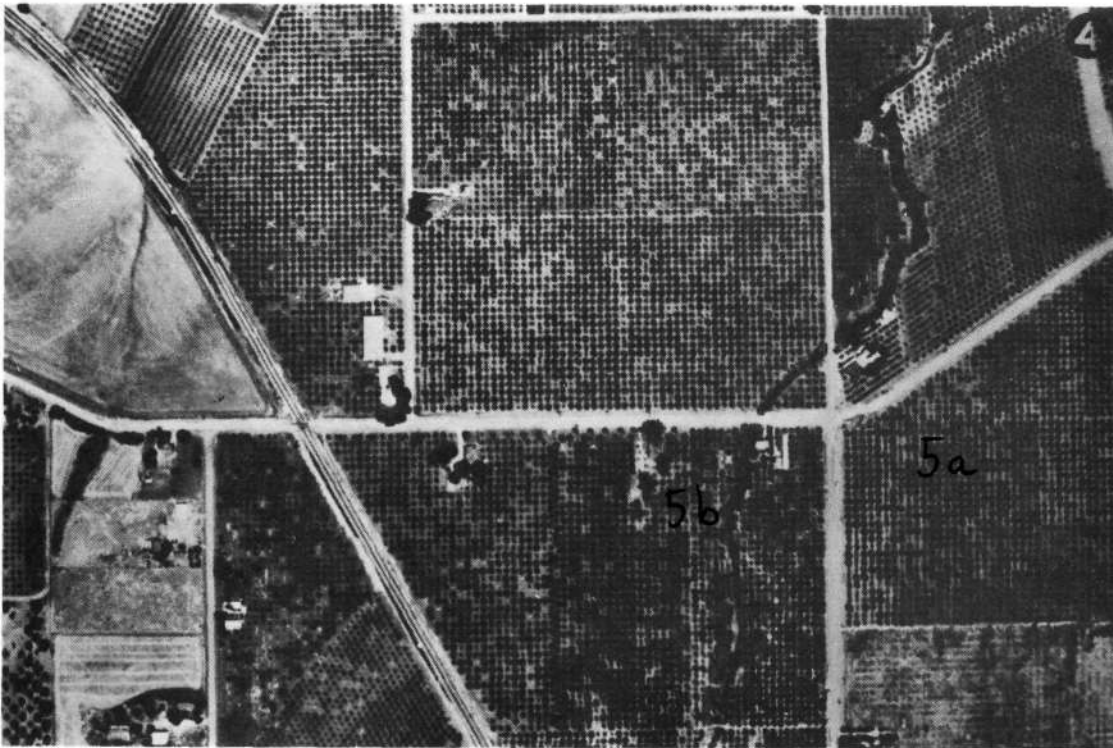

Plate 4: 1960 aerial photograph of citrus classified on earlier images as good quality. Some groves have uniform crown closure but the majority of groves are not as good. North is on the left. (City of Industry, and part of Rowland Heights, California).

Plate 5: 1970-71 citrus distribution has taken many forms. The above photograph views a subdivision lying in the citrus grove marked 5b, as seen from 5a in an abandoned grove (Rowland Heights, California).

Plate 6: Citrus may be preserved along with some walnuts in residential areas until other uses succeed (Rowland Heights, California).

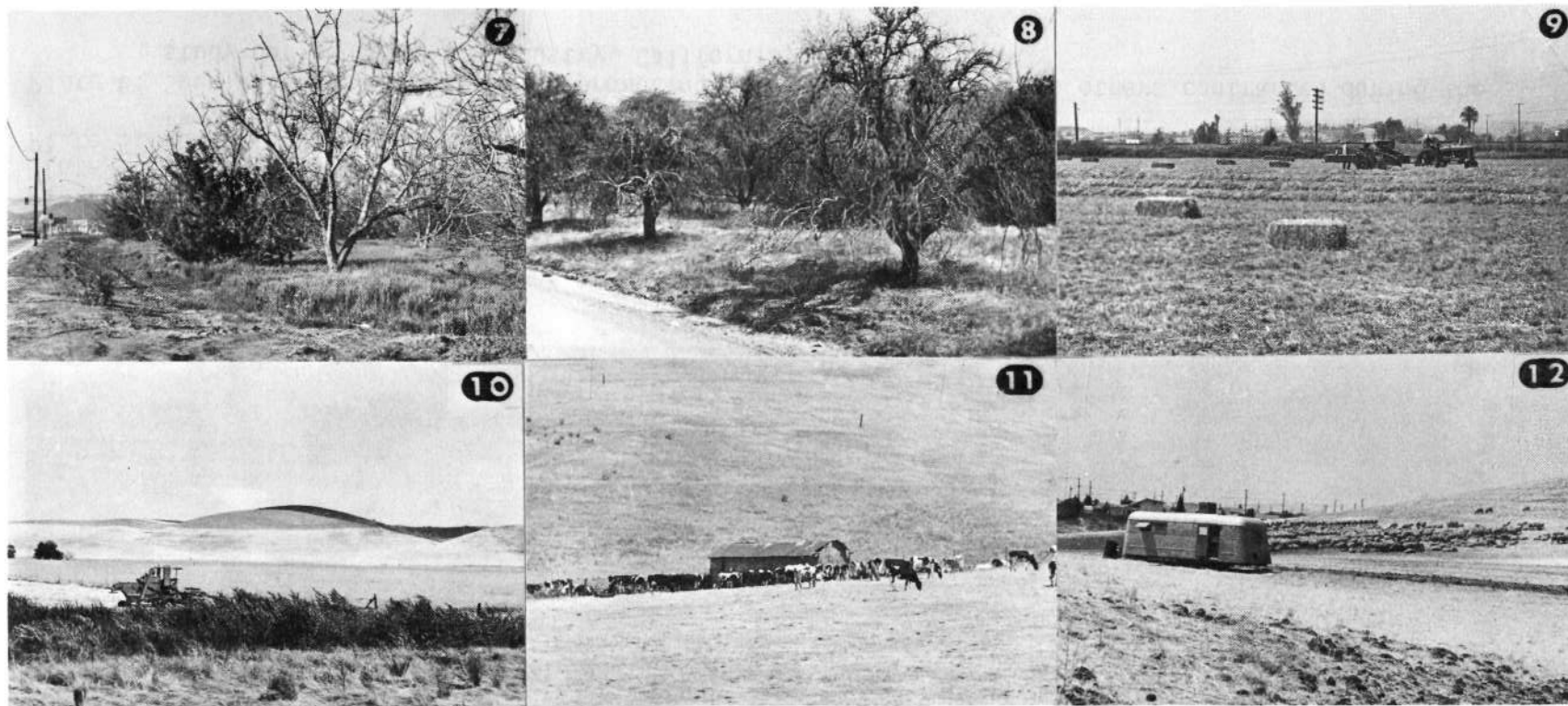

Plate 7: Disinvested, abandoned walnut acreage (City of Industry, California).

Plate 8: Disinvested, abandoned citrus acreage (City of Industry, California).

Plate 9: Extensive barley raising agriculture, the harvesting of grain straw (City of Industry, California).

Plate 10: Extensive barley raising agricultural landscape (Walnut, California).

Plate 11: Natural and volunteer grasses grazed by dairy and beef cattle (Rowland Heights, California).

Plate 12: Sheep grazing barley stubble adjacent to residential area (Walnut, California).

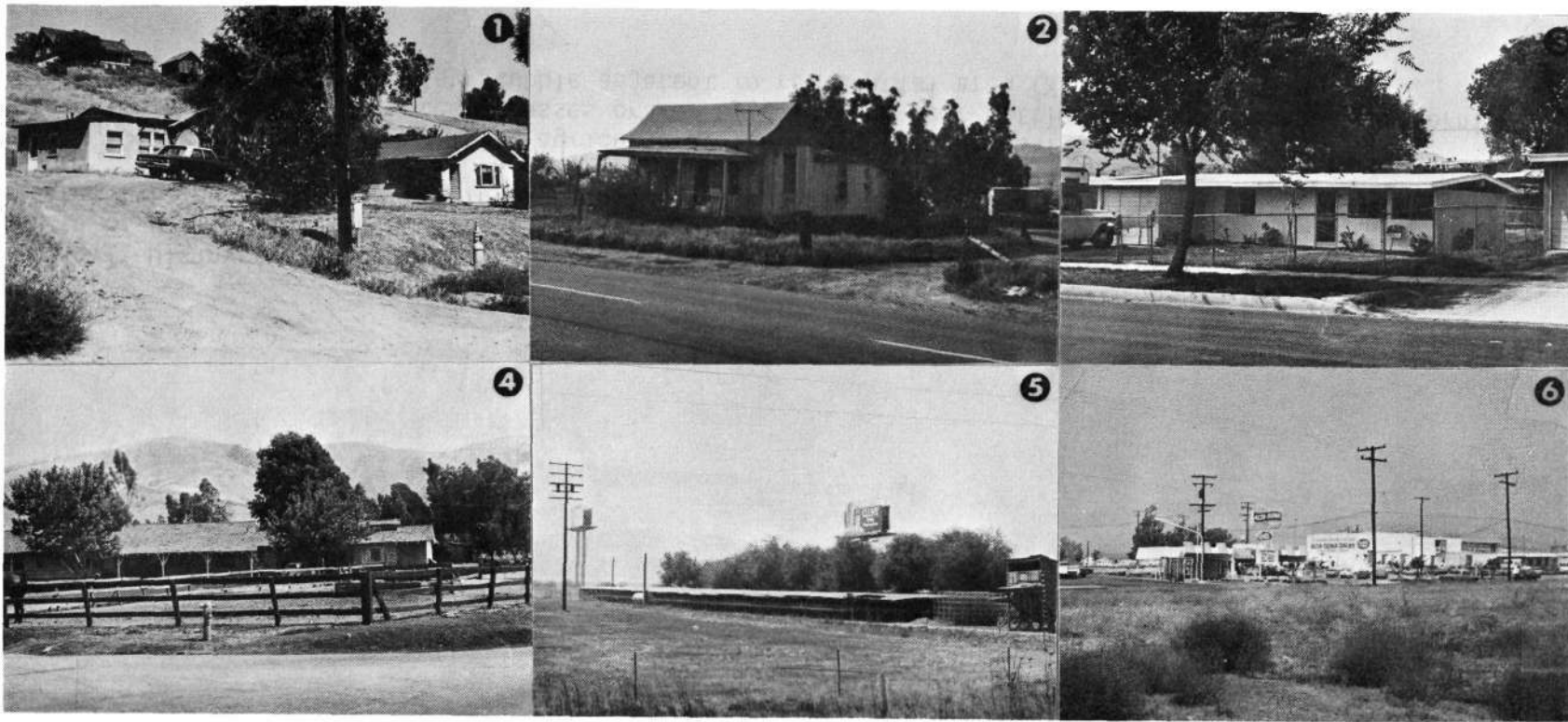

APPENDIX B

- Plate 1: Housing built in the 1920's far beyond the fringe of that day (Walnut, California).
 Plate 2: Rural farm dwelling of the 1910-20 walnut growing expansion period (City of Industry, California).
 Plate 3: Modest-priced housing of the 1950-55 period (La Puente, California).
 Plate 4: Large lot residential-agriculture type zoning housing of the 1950's (Rowland Heights, California).
 Plate 5: Now-vacant poultry farm established on the fringe in the 1953-58 period (City of Industry, California).
 Plate 6: Specialized, certified milk producing dairy which expanded as others contracted during the study period (City of Industry, California).

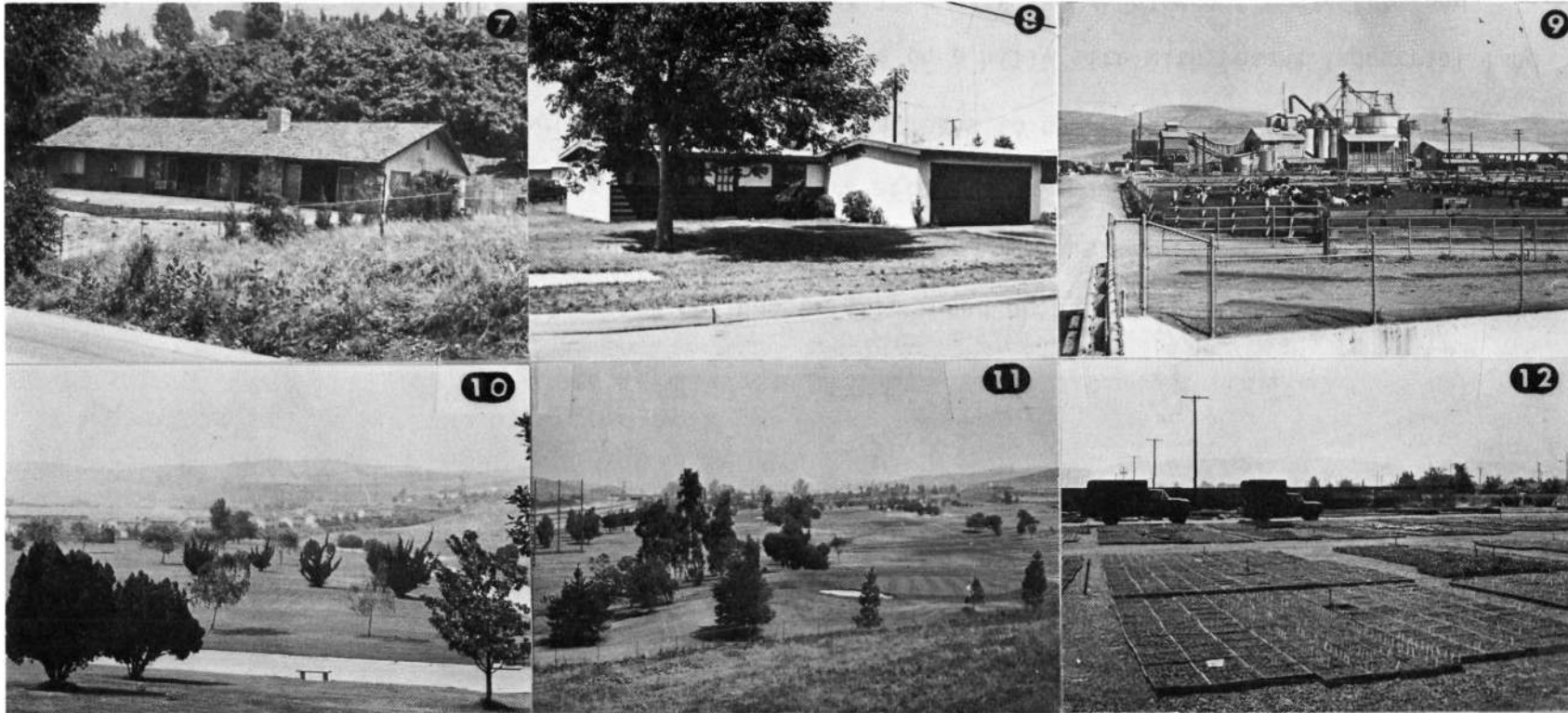

- Plate 7: Hill subdivisions tend toward one-quarter acre average lot sizes. In rugged terrain near the Puente Hills' crest, a five-acre avocado-raising pattern is common (La Habra Heights, California).
- Plate 8: Subdivision of the 1953-58 period built ahead of the fringe. One out of ten houses in some blocks is badly deteriorated (Rowland Heights, California).
- Plate 9: Cattle feed processing and feed lot operations in eastern Walnut Valley (City of Industry, California).
- Plate 10: Fringe land use of the 1958-60 period (cemetery) later surrounded by subdivisions (Rowland Heights, California).
- Plate 11: Former row crop acreage converted in 1960-65 to a golf course. Note the adjacent freeway (Diamond Bar, California).
- Plate 12: Thirty-five acre nursery, situated in residential area, attracted to Walnut Valley because of the freeway (Rowland Heights, California).

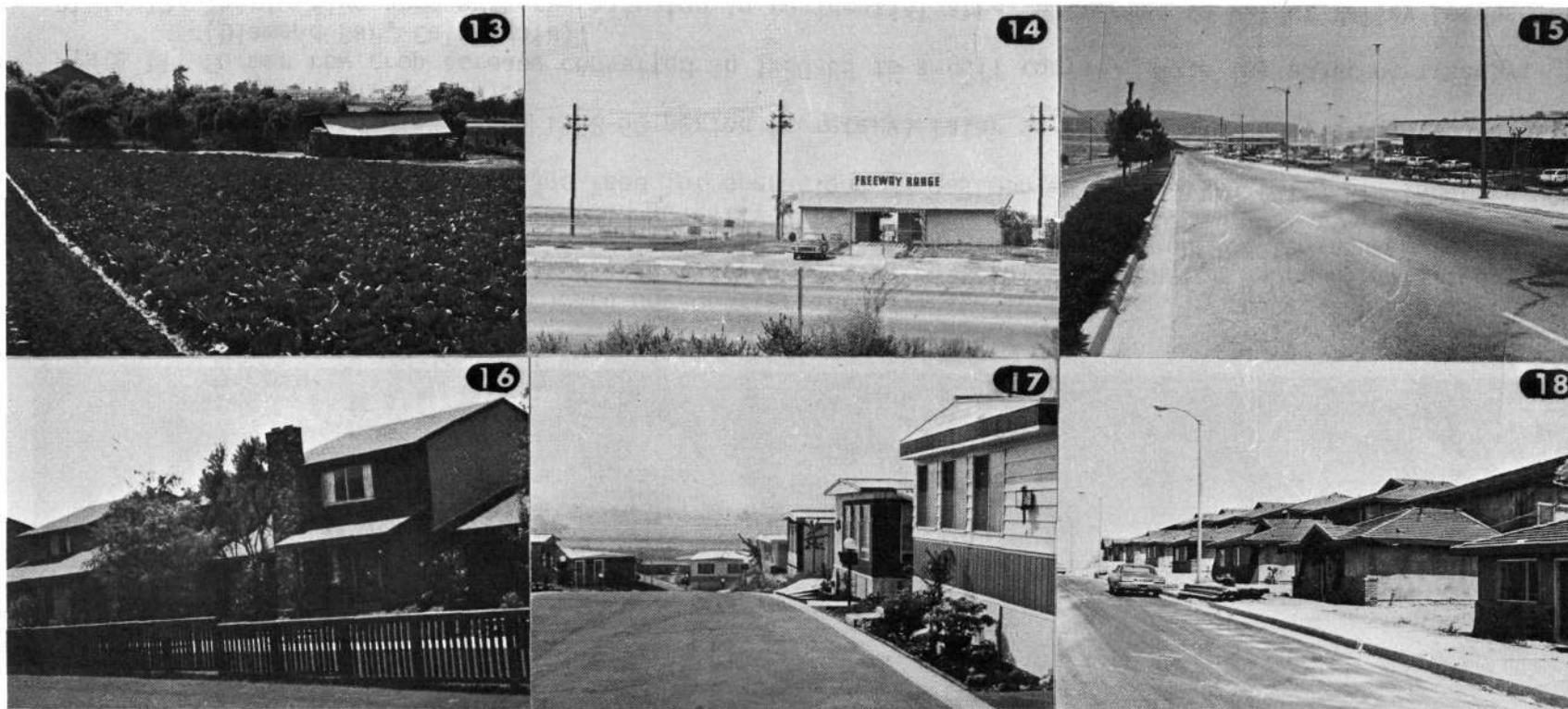

Plate 13: Row cropped fields and packing shed on industrially zoned property abutting the freeway (City of Industry, California).

Plate 14: Semi-permanent commercial land use (golf driving range) on industrially zoned property adjacent to the freeway (City of Industry, California).

Plate 15: Commercial center recently completed, four years after nearby housing was finished (Diamond Bar, California).

Plate 16: Common open space type subdivision recognized as a means to use hilly terrain (West Covina, California).

Plate 17: Commercially zoned property with trailer court use on a hilly site with vacant industrial land below (West Covina, California).

Plate 18: High density residential use adapts to high cost land with low development costs (Rowland Heights, California).

DOCUMENT CONTROL DATA - R & D

(Security classification of title, body of abstract and indexing annotation must be entered when the overall report is classified)

1. ORIGINATING ACTIVITY (Corporate author)		2a. REPORT SECURITY CLASSIFICATION	
University of California, Riverside Department of Geography		Unclassified	
		2b. GROUP	
1. REPORT TITLE			
MONITORING THE EVOLVING LAND USE PATTERNS ON THE LOS ANGELES METROPOLITAN FRINGE USING REMOTE SENSING			
4. DESCRIPTIVE NOTES (Type of report and inclusive dates)			
Technical Report T-71-5 (October 1971)			
5. AUTHOR(S) (First name, middle initial, last name)			
Darryl R. Goehring			
6. REPORT DATE	7a. TOTAL NO. OF PAGES	7b. NO. OF REFS	
October 1971	109	51	
8a. CONTRACT OR GRANT NO.	9a. ORIGINATOR'S REPORT NUMBER(S)		
ONR N00014-69-A-0200-5001	Technical Report T-71-5		
b. PROJECT NO.			
NR 387-047			
c.	9b. OTHER REPORT NO(S) (Any other numbers that may be assigned this report)		
d.			
10. DISTRIBUTION STATEMENT			
This document has been approved for public release and sale; its distribution is unlimited.			
11. SUPPLEMENTARY NOTES		12. SPONSORING MILITARY ACTIVITY	
		Geography Branch Office of Naval Research Arlington, Virginia 22217	
13. ABSTRACT			
<p>The urbanization of Walnut Valley from 1953-71 prompted land use change from intensive von Thünen market-oriented patterns to extensive, disinvested, production-factor-minimized patterns. Land owners disinvested as they realized the infeasibility of long-run planning in a situation that became dynamic when a freeway was to be built and the succession of urban uses was assured. Variety in the change was attributed to the different decisions pre-development land owners made as they perceived urban growth incentives and how they timed and selected decisions in keeping with prospects for land sales. Short-run, interim land use planning, has allowed agriculture to persist but only in the form of barley farming and grazing.</p> <p>Aerial photography used synoptically recorded six periods of land use change that bracketed dates before and after the freeway was announced and built. Interpretations of these changes help recognize potential conversions to urban uses which allow guidelines to be established that deal with rural-urban transition problems before they arise.</p>			

14. KEY WORDS	LINK A		LINK B		LINK C	
	ROLE	WT	ROLE	WT	ROLE	WT
Walnut Valley, California Land use change Los Angeles urban fringe Von Thünen zonation Monitoring change Urban dynamics Remote Sensing Photo-interpretation						

UNCLASSIFIED DISTRIBUTION LIST
Reports of Contract N00014-69-A-0200-5001, Project NR-387-047

Chief of Naval Research Geography Program, Code 414 Office of Naval Research Washington, D.C. 22217	Commanding Officer Naval Reconnaissance and Technical Support Center Washington, D.C. 20390	Dr. Carl O. Sauer Department of Geography University of California Berkeley, California 94720
Defense Documentation Center Cameron Station Alexandria, Virginia 22314	Dr. Richard O. Stone Department of Geology University of Southern California Los Angeles, California 90007	Assistant Director for Research and Development Coast and Geodetic Survey, ESSA Washington, D.C. 20390
Director, Naval Research Laboratory Attention Technical Information Office Washington, D.C. 20390	Waterways Experiment Station U. S. Corps of Engineers Vicksburg, Mississippi 39180 Attn Head, Research Center Library	Naval Scientific and Technical Intelligence Center 4301 Suitland Road Washington, D.C. 20390
Director Office of Naval Research Branch Office 1030 East Green Street Pasadena, California	Dr. Donn S. Gorsline Department of Geology University of Southern California Los Angeles, California	Mr. D. T. Hooder North American Rockwell Corp. Space Division 12214 Lakewood Blvd. Downey, California 90241
Director Office of Naval Research Branch Office 219 South Dearborn Street Chicago, Illinois 60604	Dr. William W. Wood Dept. of Natural Sciences Kedzie Laboratory Michigan State University East Lansing, Michigan 48823	Dr. Robert J. Byrne Virginia Institute of Marine Science Gloucester Point, Virginia 23062
Chief of Naval Research Ocean Science & Technology Group Code 489 Office of Naval Research Washington, D.C. 22217	Library American Geographical Society Broadway at 156th Street New York, New York 10032	Library, Geological Survey of Canada Room 350 601 Booth Street Ottawa 1, Canada
Chief of Naval Research Code 463 Surface and Amphibious Programs Office of Naval Research Washington, D.C. 22217	Dr. Richard A. Davis, Jr. Department of Geology Western Michigan University Kalamazoo, Michigan 49001	The Library Department of Geography University of Cambridge Downing Place Cambridge, England
Chief of Naval Operations Op 07F, Technical Analysis Department of the Navy Washington, D.C. 20350	Chief of Naval Research Code 460 Naval Applications and Analysis Division Office of Naval Research Arlington, Virginia	The Library Royal Geographical Society Kensington Grove London, S. W. 1, England
Dr. A. L. Slafkosky Scientific Advisor Commandant of the Marine Corps (Code AX) Washington, D.C. 20380	Dr. William S. Gaither, Dean College of Marine Studies Robinson Hall University of Delaware Newark, Delaware 19711	Dr. Robert Dolan Department of Geography University of Virginia Charlottesville, Virginia 22903
Commanding General Army Topographic Command 6500 Brooks Lane Washington, D.C. 20315	Dr. John C. Ludwick Institute of Oceanography Old Dominion University P. O. Box 6173 Norfolk, Virginia 23508	Commanding Officer Naval Ship Research and Development Laboratory Panama City, Florida 32401
Director Coastal Engineering Research Center Corps of Engineers, U. S. Army 5201 Little Falls Road, N. W. Washington, D.C. 20315	Dr. Roger A. Leestma U. S. Army Topographic Command Corps of Engineers Research Institute 701 Prince Street Alexandria, Virginia 22314	Dr. Kenneth O. Emery Department of Geology Woods Hole Oceanography Inst. Woods Hole, Massachusetts 02543
Central Intelligence Agency Attention OCR/DD-Publications Washington, D.C. 20505	Dr. William T. Fox Department of Geology Williams College Williamstown, Mass., 01267	Office of Naval Research Scientific Liaison Officer Scripps Institution of Oceanography La Jolla, California 92038
U. S. Coast Guard (D-62) Washington, D.C. 20591	Dr. Robert L. Miller Department of Geophysical Sciences University of Chicago Chicago, Illinois 60637	National Institute of Oceanography Wormley Godalming, Surrey, England
President Naval War College Newport, Rhode Island 02840	Naval Academy Library U. S. Naval Academy Annapolis, Maryland 21402	Coastal Studies Inst. Louisiana State University Baton Rouge, Louisiana 70803
Dr. James P. Latham Department of Geography Florida Atlantic University Boca Raton, Florida 33432	Commander Naval Oceanographic Office Attention Library (Code 1640) Washington, D.C. 20390	Dr. Warren C. Thompson Department of Meteorology and Oceanography U. S. Naval Post Grad. School Monterey, California 93940
Defense Intelligence Agency DIAAP-10A Washington, D.C. 20301		Comite Central D Oceanographic Et d Etude des Cotes 13 Rue de l Universite Paris 7E, France

THEMIS