

CODE IDENT NO 25500

GOODYEAR AEROSPACE CORPORATION

AKRON, OHIO 44315

Contract Number NAS8-29144

**ENGINEERING DESIGN MANUAL OF PARACHUTE
DECCELERATOR CHARACTERISTICS FOR SPACE
SHUTTLE SOLID ROCKET BOOSTER RECOVERY**

GER-15887

May 1, 1973

Prepared By David L. Mansfield

Copy Number _____

FOREWORD

This report has been prepared by Goodyear Aerospace Corporation under Contract Number NAS 8-29144 entitled, "Assessment of Loads Resulting from Parachute Deceleration System", for the George C. Marshall Space Flight Center of the National Aeronautics and Space Administration. The work of this contract was performed from November 2, 1972 through May 1, 1973.

The primary contributing personnel at Goodyear Aerospace Corporation were Mr. David L. Mansfield, Project Engineer and Mr. James Burbick, Flight Dynamicist.

The MSFC Contracting Officers Representative was Mr. James Herring, S&E-ASTN-AAD.

TABLE OF CONTENTS

Section	Title	Page
	Forward	i
	Table of Contents	ii
	List of Figures	iv
	List of Tables.	xi
I	Introduction	1
A.	General	1
B.	Model Description	1
II	Deceleration Definition	5
A.	General	5
B.	Define Main Stage Decelerators	7
1.	General	7
2.	Determine Terminal Ballistic Coefficient	7
3.	Determine Dynamic Pressure For Main Deployment	9
4.	Determine Parachute Size Number And Type.	10
5.	Calculate Parachute System Weight.	23
6.	Example Problem.	27
7.	Select Deployment Conditions, Inflation Times, And Reefing Times	29
C.	Definition Of Drogue Parachute Decelerator	46
1.	General	46
2.	Drogue Parachute Sizing	60
3.	Drogue Deployment Conditions	60

Section	Title	Page
	4. Calculation Of Drogue Parachute System Weight	63
	5. Example Problem.	111
III	Supplementary Parachute Characteristics	114
A.	General	114
B.	Mass Properties	114
C.	Spring Characteristics	119
D.	Aerodynamic Characteristics	122
E.	Inflation Characteristics	126
IV	Conclusions And Recommendations	132
A.	Conclusions	132
B.	Recommendations	133

LIST OF FIGURES

Figure No.	Title	Page
1.	Computer Model Representation	2
2.	Typical Bridling Arrangements	4
3.	SRB Recovery Envelope	6
4.	Parachute Decelerator Definition Functional Flow	8
5.	Stages of Parachute Inflation.	11
6.	Main Parachute Deployment Q Versus Terminal Velocity For 3 G's Deceleration.	12
7.	Main Parachute Deployment Q Versus Terminal Velocity For 3.5 G's Deceleration.	13
8.	Main Parachute Deployment Q Versus Terminal Velocity For 4.0 G's Deceleration.	14
9.	Main Parachute Drag Characteristics	16
10.	Parachute Cluster Efficiency	17
11.	Parachute Diameter Versus Total Weight For 3 Parachutes	18
12.	Parachute Diameter Versus Total weight For 6 Parachutes	19
13.	Parachute Diameter Versus Total Weight For 9 Parachutes	20
14.	Riser Length Criteria For Parachute Clusters	22
15.	General Bridle Arrangements	24
15A.	Main Parachute Weight As A Percent Of SRB Weight Versus Terminal Velocity	28
16.	Parachute Filling Time Ratio t_f/D_0 Versus Snatch Velocity	31
17.	Altitude Loss Versus Initial Altitude: G's = 3.0; $t_f = 1$ Sec; $\gamma = -90^\circ$	34
18.	Altitude Loss Versus Initial Altitude: G's = 3.0; $t_f = 3$ Sec; $\gamma = -90^\circ$	35

LIST OF FIGURES

Figure No.	Title	Page
19.	Altitude Loss Versus Initial Altitude; G's = 3. 0; $t_f = 6. 0 \text{ Sec}; \gamma = -90^0$	36
20.	Altitude Loss Versus Initial Altitude; G's = 3. 0; $t_f = 9. 0 \text{ Sec}; \gamma = -90^0$	37
21.	Altitude Loss Versus Initial Altitude; G's = 3. 0; $t_f = 12. 0 \text{ Sec}; \gamma = -90^0$	38
22.	Altitude Loss Versus Initial Altitude; G's = 3. 0; $t_f = 15. 0 \text{ Sec}; \gamma = -90^0$	39
23.	Altitude Loss Versus Initial Altitude; G's = 3. 0; $t_f = 18. 0 \text{ Sec}; \gamma = -90^0$	39A
24.	Altitude Loss Versus Critical Altitude; G's = 3. 0; $t_f = 21. 0 \text{ Sec}; \gamma = -90^0$	40
25.	Altitude Loss Versus Initial Altitude; G's = 3. 0; $t_f = 24. 0 \text{ Sec}; \gamma = -90^0$	41
26.	Altitude Loss Versus Initial Altitude; G's = 4. 0; $t_f = 9. 0 \text{ Sec}; \gamma = -70^0$	42
27.	Altitude Loss Versus Initial Altitude; G's = 4. 0; $t_f = 15 \text{ Sec}; \gamma = -70^0$	43
28.	Altitude Loss Versus Initial Altitude; G's = 4. 0; $t_f = 24 \text{ Sec}; \gamma = -70^0$	44
29.	Reefing Time Versus Initial Altitude; G's = 3. 0; $t_f = 1 \text{ Sec}; \gamma = -90^0$	48
30.	Reefing Time Versus Initial Altitude; G's = 3. 0; $t_f = 3 \text{ Sec}; \gamma = -90^0$	49
31.	Reefing Time Versus Initial Altitude; G's = 3. 0; $t_f = 6 \text{ Sec}; \gamma = -90^0$	50
32.	Reefing Time Versus Initial Altitude; G's = 3. 0; $t_f = 9 \text{ Sec}; \gamma = -90^0$	51
33.	Reefing Time Versus Initial Altitude; G's = 3. 0; $t_f = 12 \text{ Sec}; \gamma = -90^0$	52

LIST OF FIGURES

Figure No.	Title	Page
34	Reefing Time Versus Initial Altitude; G's = 3.0; $t_f = 15$ Sec; $\gamma = -90^\circ$	53
35	Reefing Time Versus Initial Altitude; G's = 3.0; $t_f = 18$ Sec; $\gamma = -90^\circ$	54
36	Reefing Time Versus Initial Altitude; G's = 3.0; $t_f = 21$ Sec; $\gamma = -90^\circ$	55
37	Reefing Time Versus Initial Altitude; G's = 3.0; $t_f = 24$ Sec; $\gamma = -90^\circ$	56
38	Reefing Time Versus Initial Altitude; G's = 4.0; $t_f = 9$ Sec; $\gamma = -70^\circ$	57
39	Reefing Time Versus Initial Altitude; G's = 4.0; $t_f = 15$ Sec; $\gamma = -70^\circ$	58
40	Reefing Time Versus Initial Altitude; G's = 4.0; $t_f = 24$ Sec; $\gamma = -70^\circ$	59
41	Drogue Drag Area Versus Main Parachute Deployment α	61
42	Drogue Drag Area Versus Parachute Diameter	62
43	Dynamic Pressure Versus Altitude For Drogue Deployment	64
44	Altitude Versus Dynamic Pressure, $\gamma = -90^\circ$, $t_f = 1.0$ Sec, MACH No. = 1.4, Altitude = 50,000 Ft.	65
45	Altitude Versus Dynamic Pressure, $\gamma = -90^\circ$, $t_f = 2.0$ Sec, MACH No. = 1.4, Altitude = 50,000 Ft.	66
46	Altitude Versus Dynamic Pressure, $\gamma = -90^\circ$, $t_f = 4.0$ Sec, MACH No. = 1.4, Altitude = 50,000 Ft.	67
47	Altitude Versus Dynamic Pressure, $\gamma = -90^\circ$, $t_f = 1.0$ Sec, MACH No. = 1.4, Altitude = 40,000 Ft.	68
48	Altitude Versus Dynamic Pressure, $\gamma = -90^\circ$, $t_f = 2.0$ Sec, MACH No. = 1.4, Altitude = 40,000 Ft.	69
49	Altitude Versus Dynamic Pressure, $\gamma = -90^\circ$, $t_f = 4.0$ Sec, MACH No. = 1.4, Altitude = 40,000 Ft.	70

LIST OF FIGURES

Figure No.	Title	Page
50	Altitude Versus Dynamic Pressure, $\gamma = 90^\circ$, $t_f = 1.0$ Sec. MACH No. = 1.4, Altitude = 30,000 Ft.	71
51	Altitude Versus Dynamic Pressure, $\gamma = -90^\circ$, $t_f = 2.0$ Sec. MACH No. = 1.4, Altitude = 30,000 Ft.	72
52	Altitude Versus Dynamic Pressure, $\gamma = -90^\circ$, $t_f = 4.0$ Sec. MACH No. = 1.4, Altitude = 30,000 Ft.	73
53	Altitude Versus Dynamic Pressure, $\gamma = -90^\circ$, $t_f = 1.0$ Sec. MACH No. = 1.0, Altitude = 50,000 Ft.	74
54	Altitude Versus Dynamic Pressure, $\gamma = -90^\circ$, $t_f = 2.0$ Sec. MACH No. = 1.0, Altitude = 50,000 Ft.	75
55	Altitude Versus Dynamic Pressure, $\gamma = -90^\circ$, $t_f = 4.0$ Sec. MACH No. = 1.0, Altitude = 50,000 Ft.	76
56	Altitude Versus Dynamic Pressure, $\gamma = -90^\circ$, $t_f = 1.0$ Sec. MACH No. = 1.0, Altitude = 40,000 Ft.	77
57	Altitude Versus Dynamic Pressure, $\gamma = -90^\circ$, $t_f = 2.0$ Sec. MACH No. = 1.0, Altitude = 40,000 Ft.	78
58	Altitude Versus Dynamic Pressure, $\gamma = -90^\circ$, $t_f = 4.0$ Sec. MACH No. = 1.0, Altitude = 40,000 Ft.	79
59	Altitude Versus Dynamic Pressure, $\gamma = -90^\circ$, $t_f = 1.0$ Sec. MACH No. = 1.0, Altitude = 30,000 Ft.	80
60	Altitude Versus Dynamic Pressure, $\gamma = -90^\circ$, $t_f = 2.0$ Sec. MACH No. = 1.0, Altitude = 30,000 Ft.	81
61	Altitude Versus Dynamic Pressure, $\gamma = -90^\circ$, $t_f = 4.0$ Sec. MACH No. = 1.0, Altitude = 30,000 Ft.	82
62	Altitude Versus Dynamic Pressure, $\gamma = -90^\circ$, $t_f = 1.0$ Sec. MACH No. 0.6, Altitude = 50,000 Ft.	83
63	Altitude Versus Dynamic Pressure, $\gamma = -90^\circ$, $t_f = 2.0$ Sec. MACH No. = 0.6, Altitude = 50,000 Ft.	84
64	Altitude Versus Dynamic Pressure, $\gamma = -90^\circ$, $t_f = 4.0$ Sec. MACH No. = 0.6, Altitude = 50,000 Ft.	85

LIST OF FIGURES

Figure No.	Title	Page
65	Altitude Versus Dynamic Pressure, $\gamma = -90^{\circ}$, $t_f = 1.0$ Sec. MACH No. = 0.6, Altitude = 40,000 Ft.	86
66	Altitude Versus Dynamic Pressure, $\gamma = -90^{\circ}$, $t_f = 2.0$ Sec. MACH No. = 0.6, Altitude = 40,000 Ft.	87
67	Altitude Versus Dynamic Pressure, $\gamma = -90^{\circ}$, $t_f = 4.0$ Sec. MACH No. = 0.6, Altitude = 40,000 Ft.	88
68	Altitude Versus Dynamic Pressure, $\gamma = -90^{\circ}$, $t_f = 1.0$ Sec. MACH No. = 0.6, Altitude = 30,000 Ft.	89
69	Altitude Versus Dynamic Pressure, $\gamma = -90^{\circ}$, $t_f = 2.0$ Sec. MACH No. = 0.6, Altitude = 30,000 Ft.	90
70	Altitude Versus Dynamic Pressure, $\gamma = -90^{\circ}$, $t_f = 4.0$ Sec. MACH No. = 0.6, Altitude = 30,000 Ft.	91
71	Altitude Versus Dynamic Pressure, $\gamma = -70^{\circ}$, $t_f = 1.0$ Sec. MACH No. = 1.4, Altitude = 50,000 Ft.	92
72	Altitude Versus Dynamic Pressure, $\gamma = -50^{\circ}$, $t_f = 1.0$ Sec. MACH No. = 1.4, Altitude = 50,000 Ft.	93
73	Altitude Versus Dynamic Pressure, $\gamma = -70^{\circ}$, $t_f = 1.0$ Sec. MACH No. = 1.4, Altitude = 40,000 Ft.	94
74	Altitude Versus Dynamic Pressure, $\gamma = -50^{\circ}$, $t_f = 1.0$ Sec. MACH No. = 1.4, Altitude = 40,000 Ft.	95
75	Altitude Versus Dynamic Pressure, $\gamma = -70^{\circ}$, $t_f = 1.0$ Sec. MACH No. = 1.4, Altitude = 30,000 Ft.	96
76	Altitude Versus Dynamic Pressure, $\gamma = -50^{\circ}$, $t_f = 1.0$ Sec. MACH No. = 1.4, Altitude = 30,000 Ft.	97
77	Altitude Versus Dynamic Pressure, $\gamma = -70^{\circ}$, $t_f = 1.0$ Sec. MACH No. = 1.0, Altitude = 50,000 Ft.	98
78	Altitude Versus Dynamic Pressure, $\gamma = -50^{\circ}$, $t_f = 1.0$ Sec. MACH No. = 1.0, Altitude = 50,000 Ft.	99
79	Altitude Versus Dynamic Pressure, $\gamma = -70^{\circ}$, $t_f = 1.0$ Sec. MACH No. = 1.0, Altitude = 40,000 Ft.	100

LIST OF FIGURES

Figure No.	Title	Page
80	Altitude Versus Dynamic Pressure, $\gamma = -50^\circ$, $t_f = 1.0$ Sec, MACH No. = 1.0, Altitude = 40,000 Ft.	101
81	Altitude Versus Dynamic Pressure, $\gamma = -70^\circ$, $t_f = 1.0$ Sec, MACH No. = 1.0, Altitude = 30,000 Ft.	102
82	Altitude Versus Dynamic Pressure, $\gamma = -50^\circ$, $t_f = 1.0$ Sec, MACH No. = 1.0, Altitude = 30,000 Ft.	103
83	Altitude Versus Dynamic Pressure, $\gamma = -70^\circ$, $t_f = 1.0$ Sec, MACH No. = 0.6, Altitude = 50,000 Ft.	104
84	Altitude Versus Dynamic Pressure, $\gamma = -50^\circ$, $t_f = 1.0$ Sec, MACH No. = 0.6, Altitude = 50,000 Ft.	105
85	Altitude Versus Dynamic Pressure, $\gamma = -70^\circ$, $t_f = 1.0$ Sec, MACH No. = 0.6, Altitude = 40,000 Ft.	106
86	Altitude Versus Dynamic Pressure, $\gamma = -50^\circ$, $t_f = 1.0$ Sec, MACH No. = 0.6, Altitude = 40,000 Ft.	107
87	Altitude Versus Dynamic Pressure, $\gamma = -70^\circ$, $t_f = 1.0$ Sec, MACH No. = 0.6, Altitude = 30,000 Ft.	108
88	Altitude Versus Dynamic Pressure, $\gamma = -50^\circ$, $t_f = 1.0$ Sec, MACH No. = 0.6, Altitude = 30,000 Ft.	109
89	Relative Weight Of Drogue Subsystem Versus Terminal Velocity On Main Parachutes	112
89A	Parachute Component CG Reference	114
89B	Parachute Composite CG Reference	115
89C	Parachute And Riser Composite CG Reference	116
90	Typical Geometry Of A Three Parachute Cluster	117
91	Computer Model Spring System	119
92	Area Ratio Versus Filling Time Ratio t/t_f	127

LIST OF FIGURES

Figure No.	Title	Page
93	Main Parachute Inflation Time History	129
94	Volume Ratio Versus Filling Time Ratio t/t_f .	131

LIST OF TABLES

Table Number	Title	Page
I	Cluster Efficiency Factors	15
II	Summary Of Example Deployment Conditions And Inflation Times	47
III	Summary of Reefing Times	46
IV	Cluster Confluence Half Angle	118
V	Aerodynamics of Ring Slot Parachutes In A Cluster	123
V-A	Aerodynamics of Ribbon Parachutes In A Cluster	124
VI	First Stage Inflation Characteristics	126
VII	Second Stage Inflation Characteristics	128
VIII	Full Open Inflation Characteristics	128

SECTION I
INTRODUCTION

A. General

A unique aspect of the solid rocket boosters (SRB) to be employed in launching the Space Shuttle is the requirement for their recovery for subsequent reuse. With this requirement, the need arose for the George C. Marshall Space Flight Center (MSFC) to have the capability of determining the loads which would be imparted to the SRB by the parachute deceleration system. From this need, Goodyear Aerospace Corporation was awarded NASA Contract Number NAS8-29144 to provide a method for accomplishing this. The form of the solution is a mathematical model representing two bodies which are connected together by an elastic tether. The magnitude of the loads is then obtained from a computer program (NASA Ref: PARAC) which iterates the equations of motions and in turn calculates the loads generated in the elastic tether.

The particular computer program which has been provided, has resulted from a modification to a program which was previously available at GAC. The basic modifications primarily were concerned with (1) providing a bridling representation which was compatible with that required by the water entry phase of recovery and (2) adapting for its use on the MSFC UNIVAC 1108 computer.

In addition to the computer program, a second area of effort was to conduct a parametric analysis such that the characteristics of the parachute decelerators could be readily obtained and in turn facilitate the selection of the input data required for the computer program.

The results of this contract are in the form of three basic items which include (1) the card deck (stored at MSFC on magnetic tape, MSFC program title reference: PARAC), (2) Program Users Manual; GER-15853, and (3) Engineering Design Manual; GER-15887 (presented herein).

The purpose of this document is to provide the user of the computer program with the capability of defining realistic approximations for input data for both the drogue and main parachute decelerators of (a) parachute size (b) deployment conditions, (c) inflation times, (d) reefing times (e) mass properties, (f) spring characteristics, and (g) aerodynamic coefficients.

B. Model Description

A schematic of the model which is analyzed by the computer program is shown in Figure 1. The model is comprised of two bodies connected together by an elastic tether. The system is free to move in a single plane where each body has 3 degrees of freedom, 2 translational and one rotational (pitch). In general, the system is comprised of a forebody (SRB),

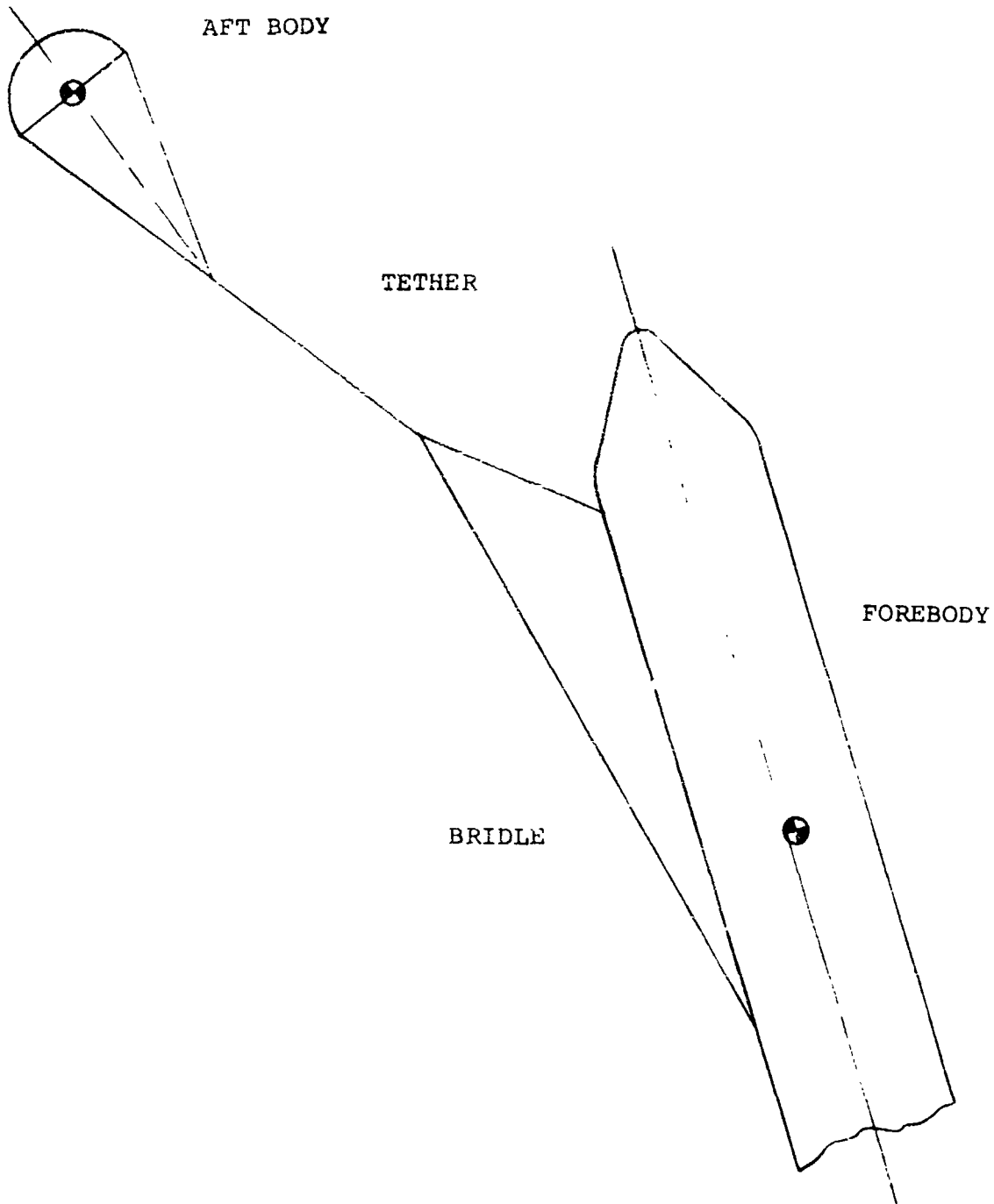

FIGURE 1 - COMPUTER MODEL REPRESENTATION

a bridle, a tether, a riser, and a parachute. It is important to note here that the model analyzes only a single parachute and since a cluster of main parachutes is being considered, an equivalent single parachute must be established. A method for determining this equivalent is provided in a later section of this report.

The model begins with the system initially stretched completely out, with the parachute at a zero inflation condition (that is, the parachute deployed but not inflated). The parachute is then allowed to inflate through each stage of reefing to full open. The inflation times are selected based on parachute diameter and velocity at the start of inflation of the particular stage.

For cases where no riser, tether, or possibly no bridle is required; these elements must be made relatively short and very stiff but they cannot be eliminated from the math model completely. Further description of this will be discussed in Section II.

Shown in Figure 2 are typical bridling configurations which might be considered. These are shown as examples and obviously reflect only a few of the possibilities.

A significant fact which must be stated here, deals with the aerodynamic characteristics of parachutes operating in clusters. The primary amount of data which exists is contained in ASD-TDR-63-159. The data presented was obtained for four parachute types (flat circular, extended skirt, ring slot, and ribbon) and varying numbers of parachutes from 1 to 7 in a cluster. For the parachute types considered applicable to the SRB requirements, (ribbon and ringslot types, only 1, 2, 3, and 5 parachutes were investigated. The data that was obtained was for the entire configuration acting as a whole, or what could be referred to as an equivalent single parachute.

A limitation of the computer program is that only one set of aerodynamic coefficients can be read into the program for a particular run. Because of this fact, if all stages of inflation are to be investigated on a single run a small error will result in the load calculations.

This error results because although the reference dimensions which are used in calculating various forces, are automatically compensated for within the program, the actual coefficients associated with various reefing ratios are not proportional to the respective size reduction. The net result is that if an accurate assessment of the loads from a particular stage of deceleration are to be determined, then a run for that particular stage should be made. (No attempt has been made to determine the error which could result, but it is anticipated that it would be small.)

The symbolism used within this document is compatible with that of the USERS MANUAL; GER-15853. For cases where conflict exists clarification will be made in the text.

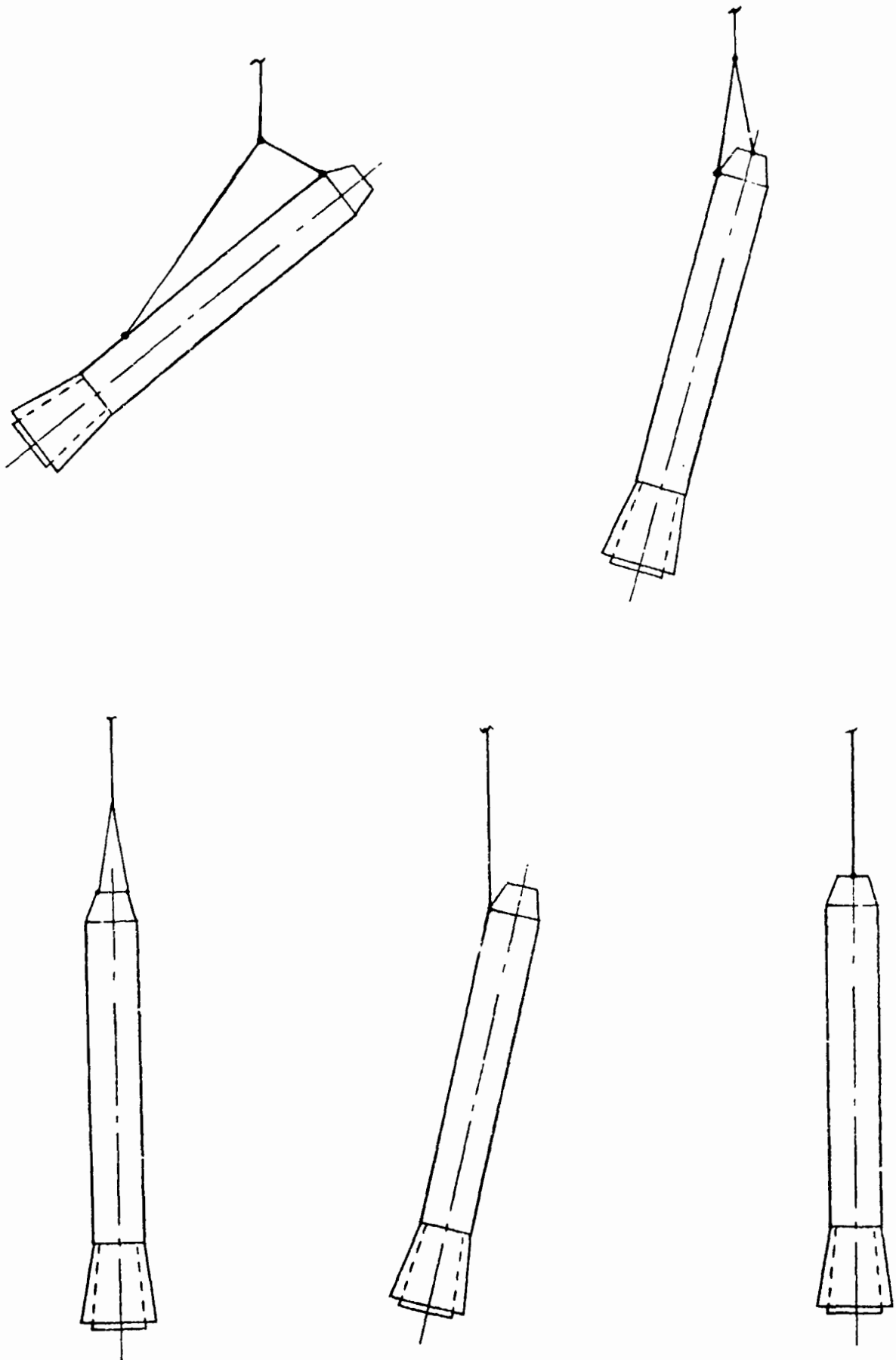

FIGURE 2 - TYPICAL BRIDLING ARRANGEMENTS

SECTION II

DECELERATION DEFINITION

A. General

The preparation of this manual has been based on the assumption that the primary user of the computer program is not familiar with parachute deceleration systems. In order to provide the user with sufficient knowledge to have a basic understanding of the rationale associated with parachute systems sizing a brief discussion is appropriate here. It is necessary to note though that as time progresses, and the SRB recovery system design is formulated, input data particular to that design must be provided to the user from the respective MSFC recovery personnel.

The purpose of the parachute deceleration system is to provide sufficient aerodynamic drag area to either decelerate, stabilize, or decelerate and stabilize the descending SRB. Generally speaking, as presently envisioned, the system which will evolve to satisfy the SRB requirements will be comprised of two basic decelerator subsystems. The first will be a drogue stage which will stabilize the SRB and assist in deceleration to a condition which is compatible with the deployment of the second decelerator subsystem (termed the main stage). This main stage will then decelerate the SRB to conditions compatible with the water entry requirements (or possibly retro-rocket initiation). In accomplishing these decelerations, it is necessary to limit the peak force to be compatible with SRB structure.

The nominal trajectory for the SRB without any parachute deceleration is shown in Figure 3 as altitude vs. dynamic pressure. The trajectories for two SRB configurations are shown to serve as approximate bounds for the environment which can be expected during SRB recovery initiation. These two cases are for the 162 inch PRR configuration and the present 142", 160,000 pound SRB.

The estimated range of terminal velocities at water entry conditions are shown to reflect the desired end point requirement. This condition is shown for an altitude range from 2,000 feet to sea level with the elevated altitude resulting to insure the system reaches its terminal ballistics prior to impacting the surface. The range of 30 feet/second to 150 feet/second has been used as bounds based on the contractual requirements. In addition, two boxes are shown which reflect the "probable drogue deployment envelope", and "probable main parachute deployment envelope". These are shown, since they are ranges which have been considered in preparation of this document.

When analyzing Figure 3, it appears that a drogue stage should not be required since the basic trajectory passes through the main envelope. The problem that exists is that the SRB as it re-enters, seeks an angle of attack of approximately $95^{\circ} \pm 10$. Although this condition provides a proper deceleration condition, it does not result in a vehicle altitude compatible with the deployment of the main parachute(s). For this reason, it is necessary to utilize a drogue parachute to re-orient or stabilize

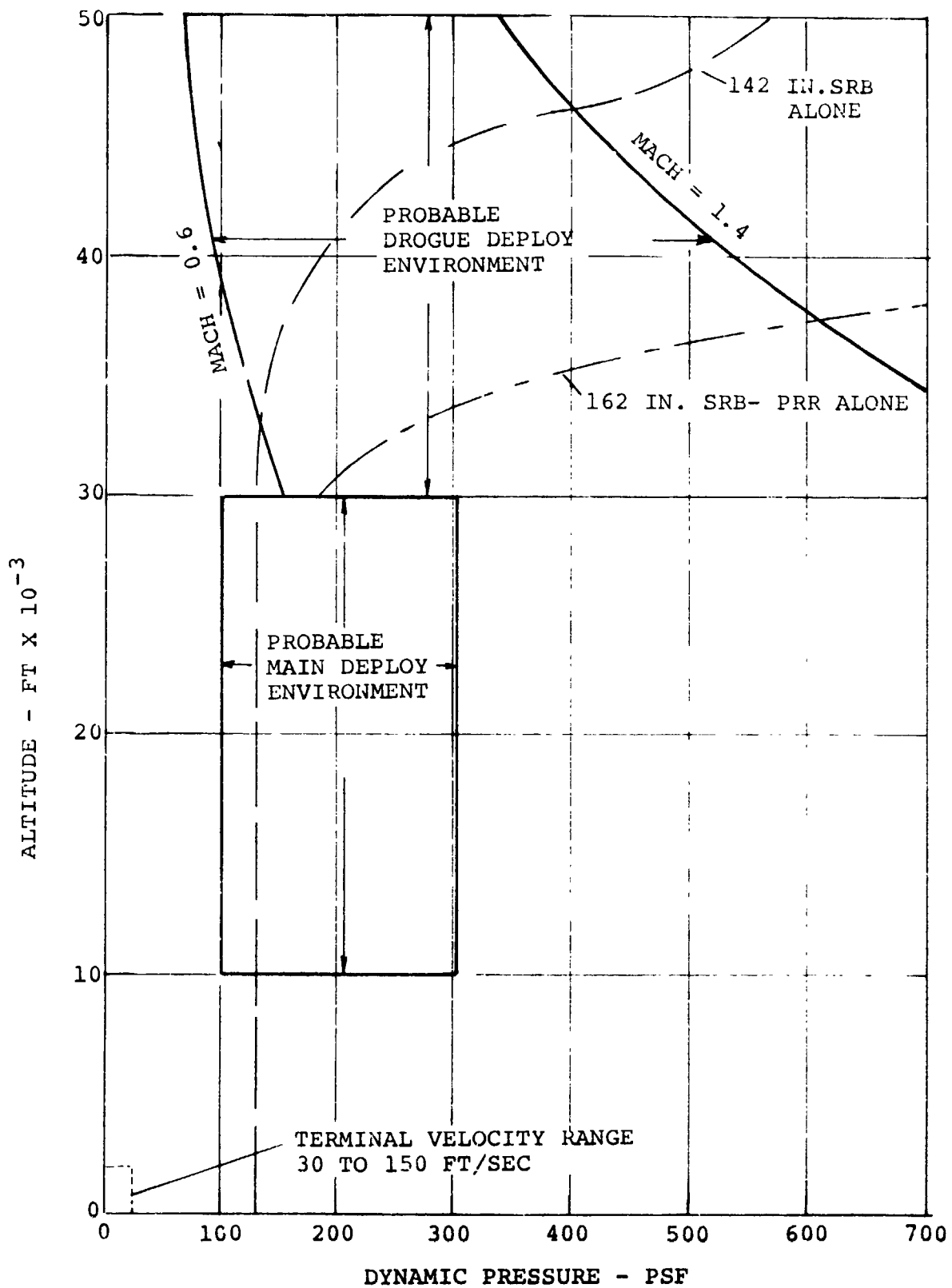

Figure 3 - SRB RECOVERY ENVELOPE

the SRB to an angle of attack of approximately 180 degrees which is compatible with main deployment.

In order to evaluate the deceleration loads imparted to the SRB, it is necessary to establish the sizes and associated characteristics of the particular drogue parachute and main parachute to accomplish this, a method has been formulated from which the required input data for the computer program can be generated. A flow chart which represents this method is shown in Figure 4 and shows the major steps required in conducting the analysis. The interaction of the drogue and mains can be seen as the schematic is followed step by step. It is necessary to first establish the main parachute characteristics and then follow up with the drogue analysis.

Presented in the following portions of this section will be a detailed description for each of the blocks shown in Figure 4 and an example for each. The input data relative to mass properties, spring characteristics and aerodynamics will then be presented in Section III.

B. Define Main Stage Decelerators

1. General

A definition of the main parachute decelerators is obtained by performing analysis to establish:

1. Parachute size
2. Number of parachutes
3. Parachute weight
4. Inflation time
5. Reefing time
6. Deployment altitude and velocity

A detailed method for determining the values for each of these is discussed in the following subsections. The method for inputting this data into the computer program will be discussed in Section III of this report.

2. Determine Terminal Ballistic Coefficient

The terminal ballistic coefficient or $W/C_D A$ is established from:

$$W = q C_D A = Mg \quad (1)$$

where: W = total descent weight which includes the weight suspended on the parachutes, and the weight of the parachutes.
N(lbs)

$$q = 1/2 \rho V^2 = \text{Dynamic Pressure} - \text{N/m}^2 \text{ (PSF)}$$

$$\rho = \text{Atmospheric Density} - \text{kg/m}^3 \text{ (slug/Ft}^3\text{)}$$

MAIN PARACHUTE DECELERATORS

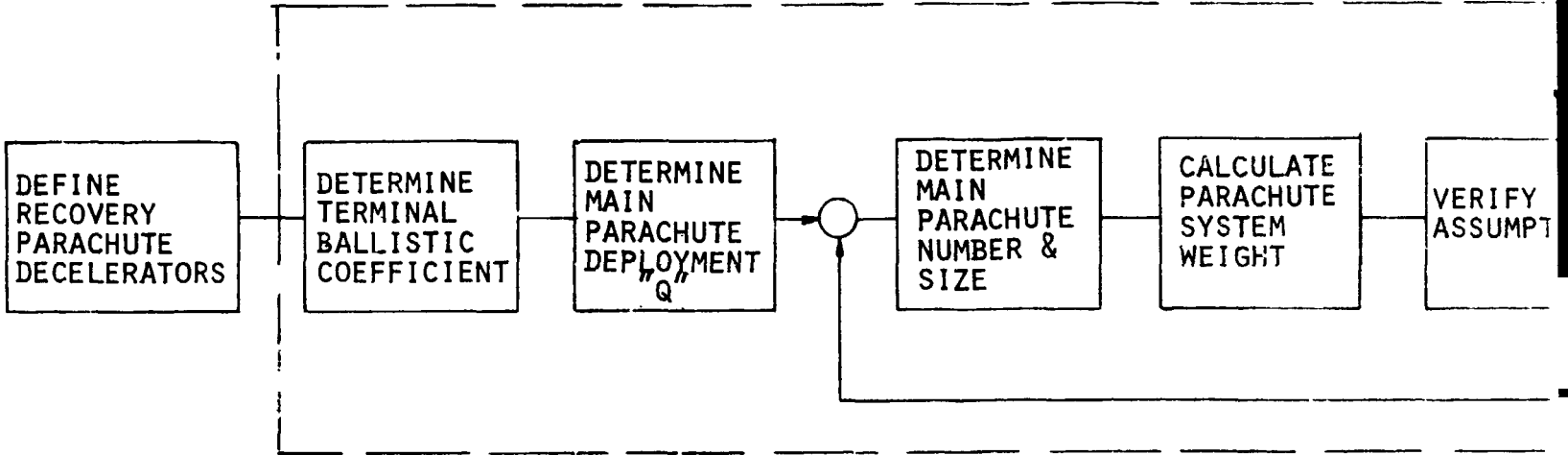

DROGUE PARACHUTE DECELERATOR

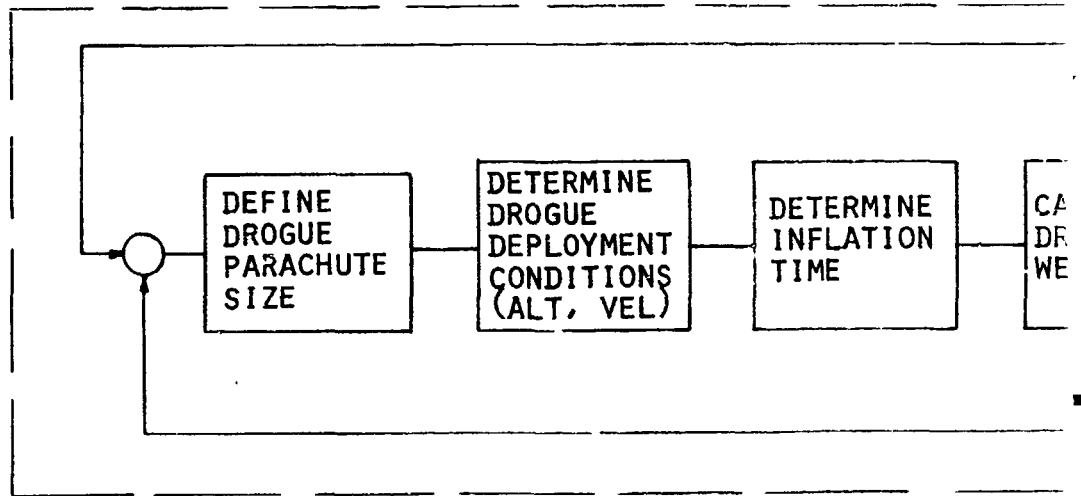

SECTION III

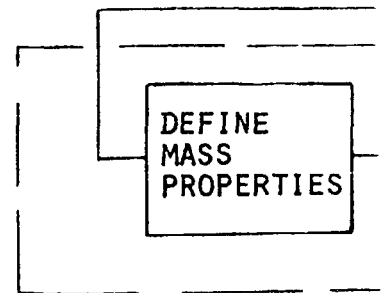

FIGURE

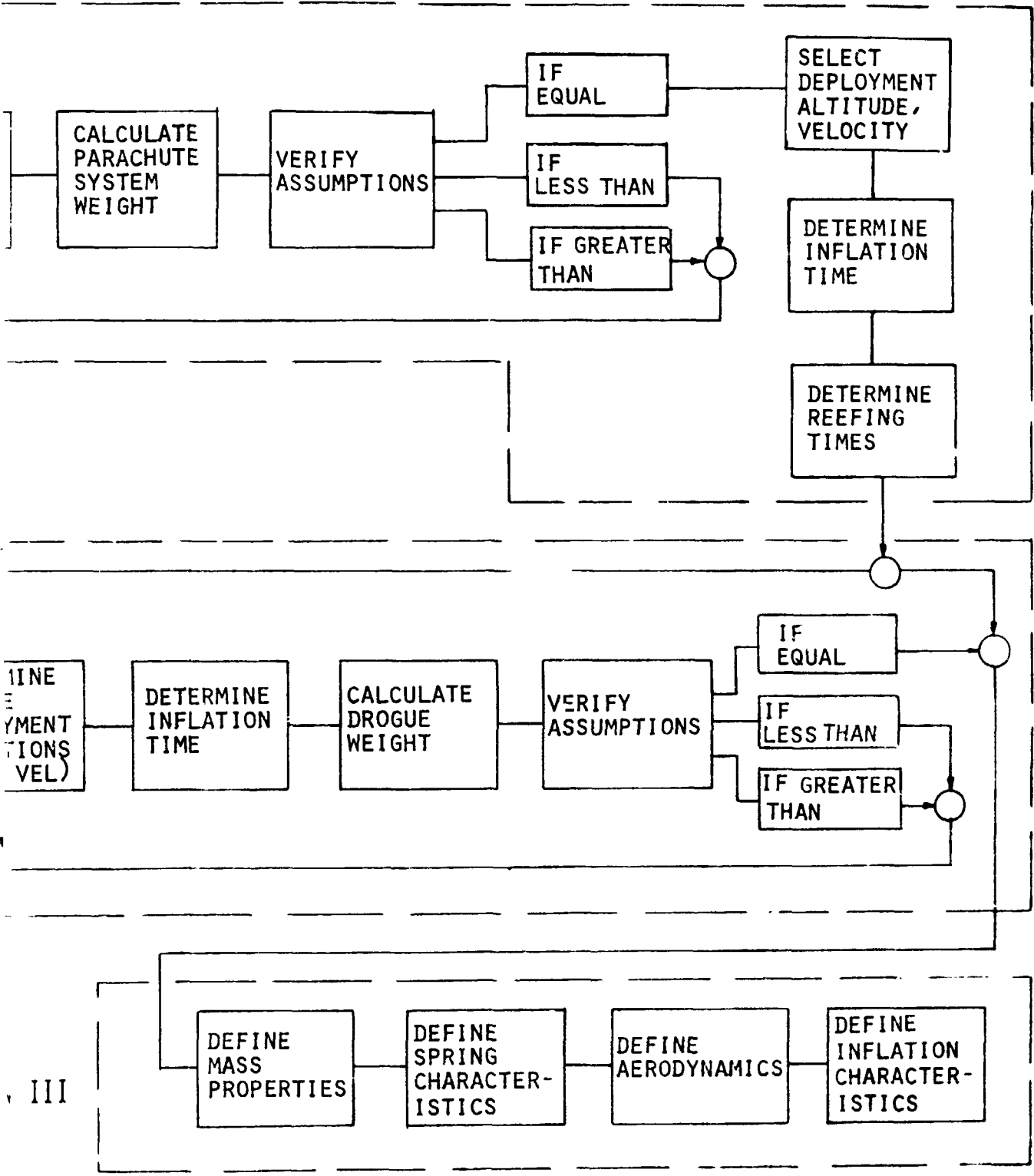

FIGURE 4 - PARACHUTE DECELERATOR DEFINITION FUNCTIONAL FLOW

$V = \text{Velocity} - \text{m/Sec (Ft/Sec)} = V_T \text{ at Terminal Velocity}$

Transposing Eq 1 into Ballistic form we get:

$$\frac{W}{C_D A} = q_T = \frac{1}{2} \rho V_T^2 \quad (2)$$

For this application, we are primarily concerned with the velocity at the time of water entry for which density $\rho = 1.227 \frac{\text{kg}}{\text{m}^3} =$

$(.00238 \text{ slug/ft}^3)$. Once the desired velocity has been selected, the

$\frac{W}{C_D A}$ can be readily obtained.

Example 1: assume $V_T = 24.39 \text{ m/sec (80 ft/sec)}$

From Eq. (2) $\frac{W}{C_D A} = 1/2 (1.227) (24.39)^2$

$$\frac{W}{C_D A} = 364. \text{ N/m}^2 (7.61 \text{ psf})$$

3. Determine Dynamic Pressure for Main Deployment

This step is required to define the maximum dynamic pressure environment in which the main parachute can be deployed without imparting forces to the vehicle in excess of the SRB's structural capability. A reasonable approximation for obtaining this value is to equate:

$$q_D = q_T (G's)^{a+1} \quad (3)$$

where $q_D = \text{Deployment dynamic pressure N/m}^2$
(psf)

$q_T = \text{terminal dynamic pressure N/m}^2$
(psf)

$G's = \text{SRB Limit Design Load Factor}$

$a = \text{Number of Peefing Stages}$

Example 2

when $G's = 3.0$

$a = 2$

$$q_T = \text{From Example 1} = 364 \text{ N/m}^2$$

$$q_D = 364 \text{ N/m}^2 (3.0)^3$$

$$q_D = 9840 \text{ N/m}^2 (205 \text{ psf})$$

A comment relative to reefing is made here for clarification to anyone unfamiliar with this terminology. If one were to consider a parachute in its full open condition, there is a maximum dynamic pressure at which it can be deployed and allowed to inflate without exceeding the SRB structural limits. Through experience, this condition is generally not high enough to be compatible with the trajectory. In order to increase the q value, the inflated area of the parachute can be controlled by reducing the circumference of the inlet (skirt edge) of the parachute. This reduction is accomplished by placing a line at this skirt edge which effectively reduces the inflated size of the parachute. This technique is referred to as reefing. Experience has shown that up to two stages of reefing can be used. The reefing lines can then be severed using pyrotechnic time delay cutters (reefing line cutters). With this method, the drag area of the parachute can be controlled such that 3 stages of deceleration can be obtained with 2 stages of reefing. A typical representation of a reefed and disreefed parachute is shown in Figure 5.

Equation 3 has been summarized graphically in Figures 6, 7 and 8 for peak deceleration forces of 3.0, 3.5, and 4.0 respectively. The maximum deployment q_D can be obtained directly when the sea level terminal velocity and number of reefing stages are selected. For deceleration other than these, Equation 3 can be used directly.

4. Determine parachute size, number and type

The terminal stage parachute size can be determined from Equation 4 for equilibrium descent at standard sea level conditions, which relates total recovered system weight, decelerator size, and terminal velocity by

$$D_o = \frac{32.7}{V_T} \left(\frac{W}{(N)(\bar{r})C_{D_o}} \right)^{1/2}, \quad (4)$$

where

D_o = parachute reference (nominal) diameter in meters, (ft)

V_T = system equilibrium descent velocity at sea level in meters per second, (Ft /Sec)

W = total recovered system weight in newtons (lbs)

N = number of parachutes in a cluster,

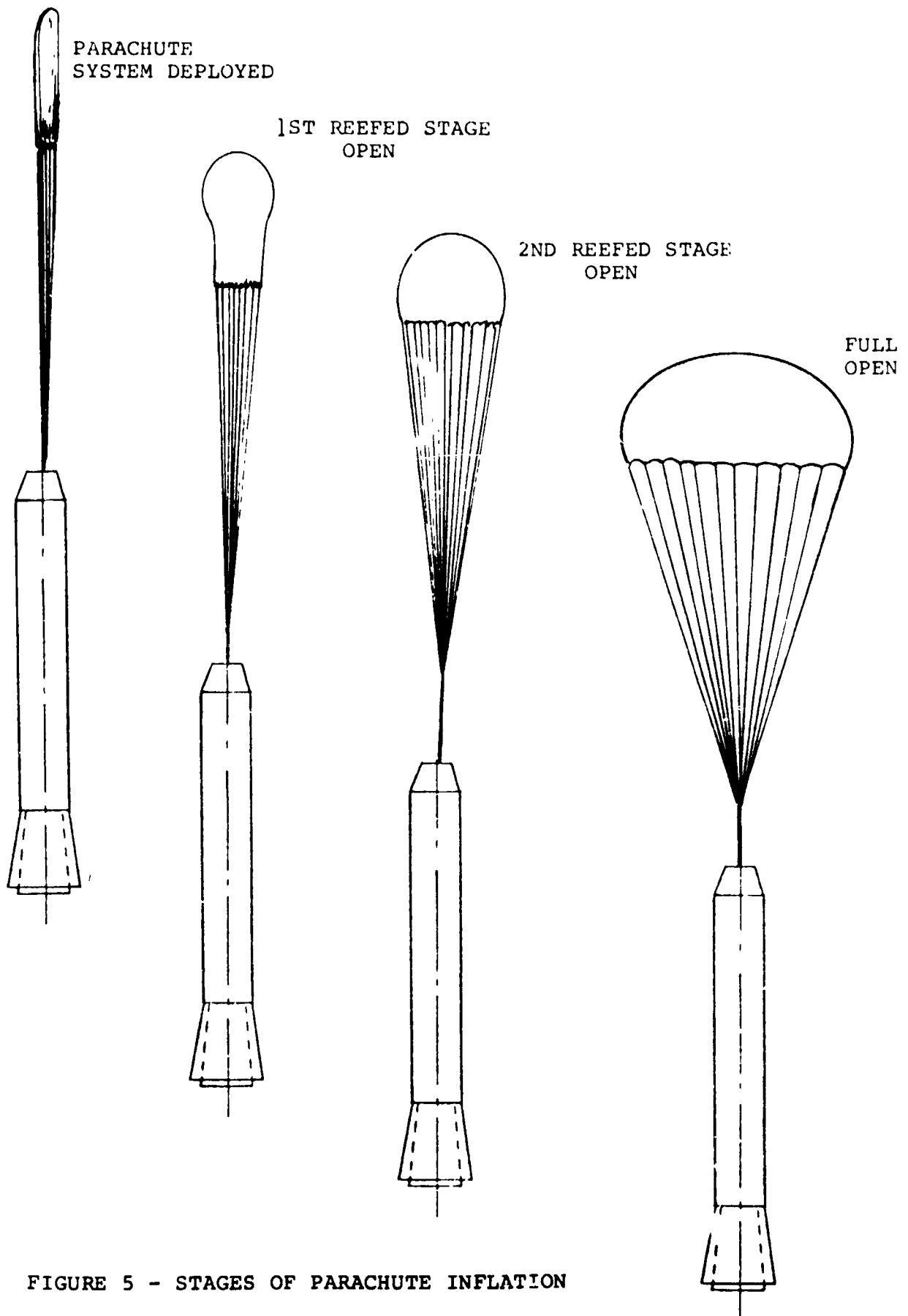

FIGURE 5 - STAGES OF PARACHUTE INFLATION

FIGURE 6

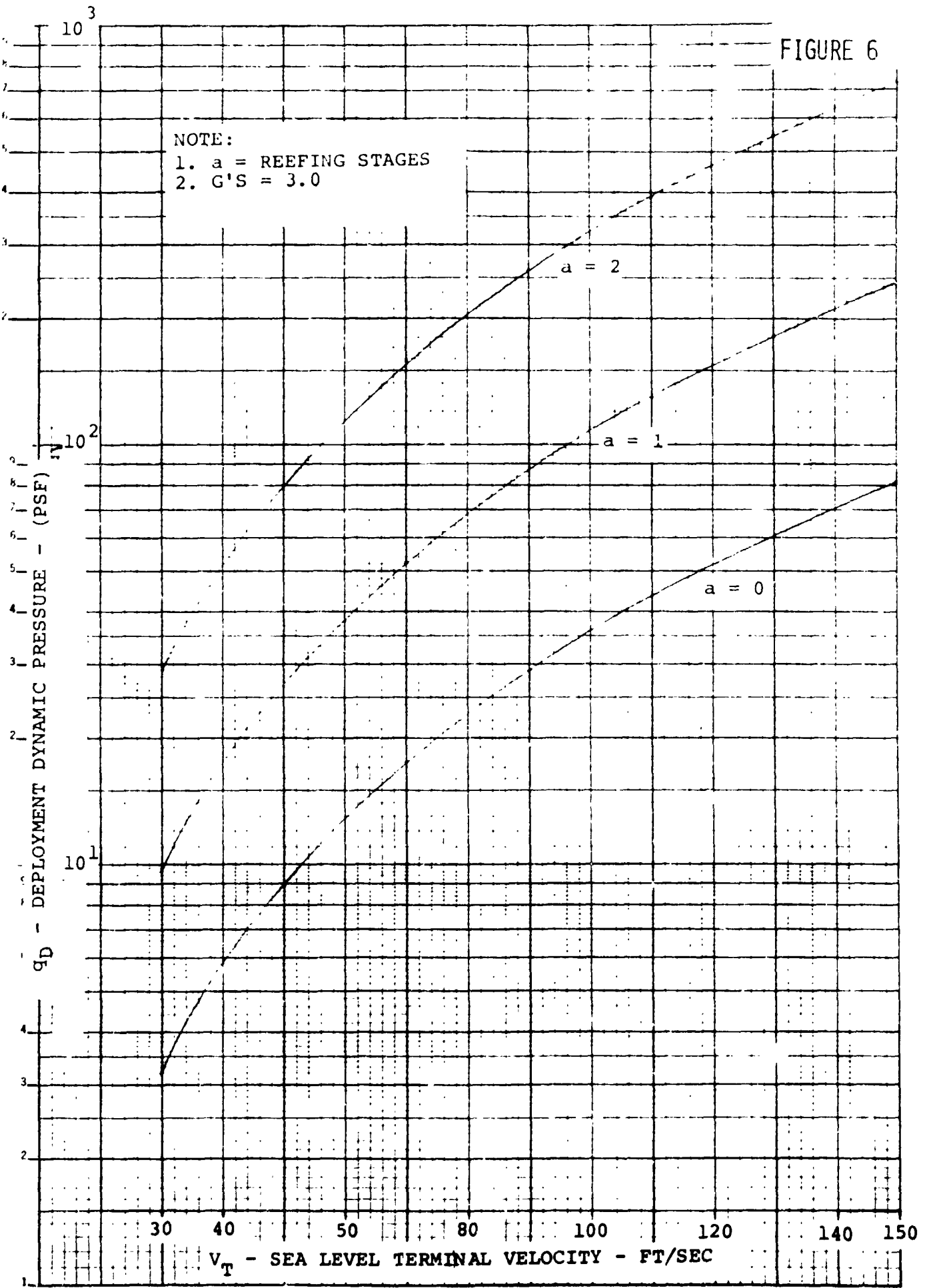
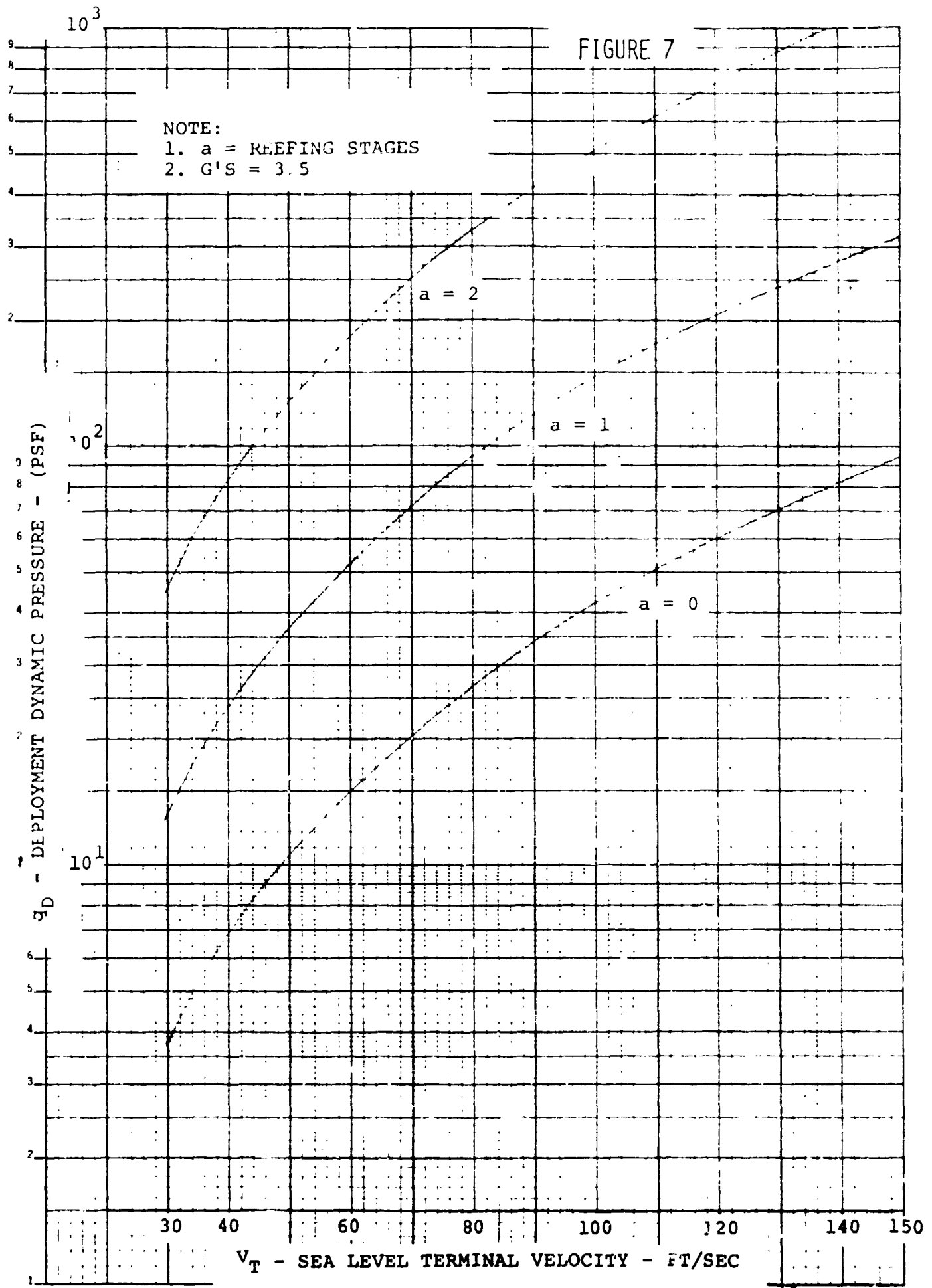

FIGURE 7



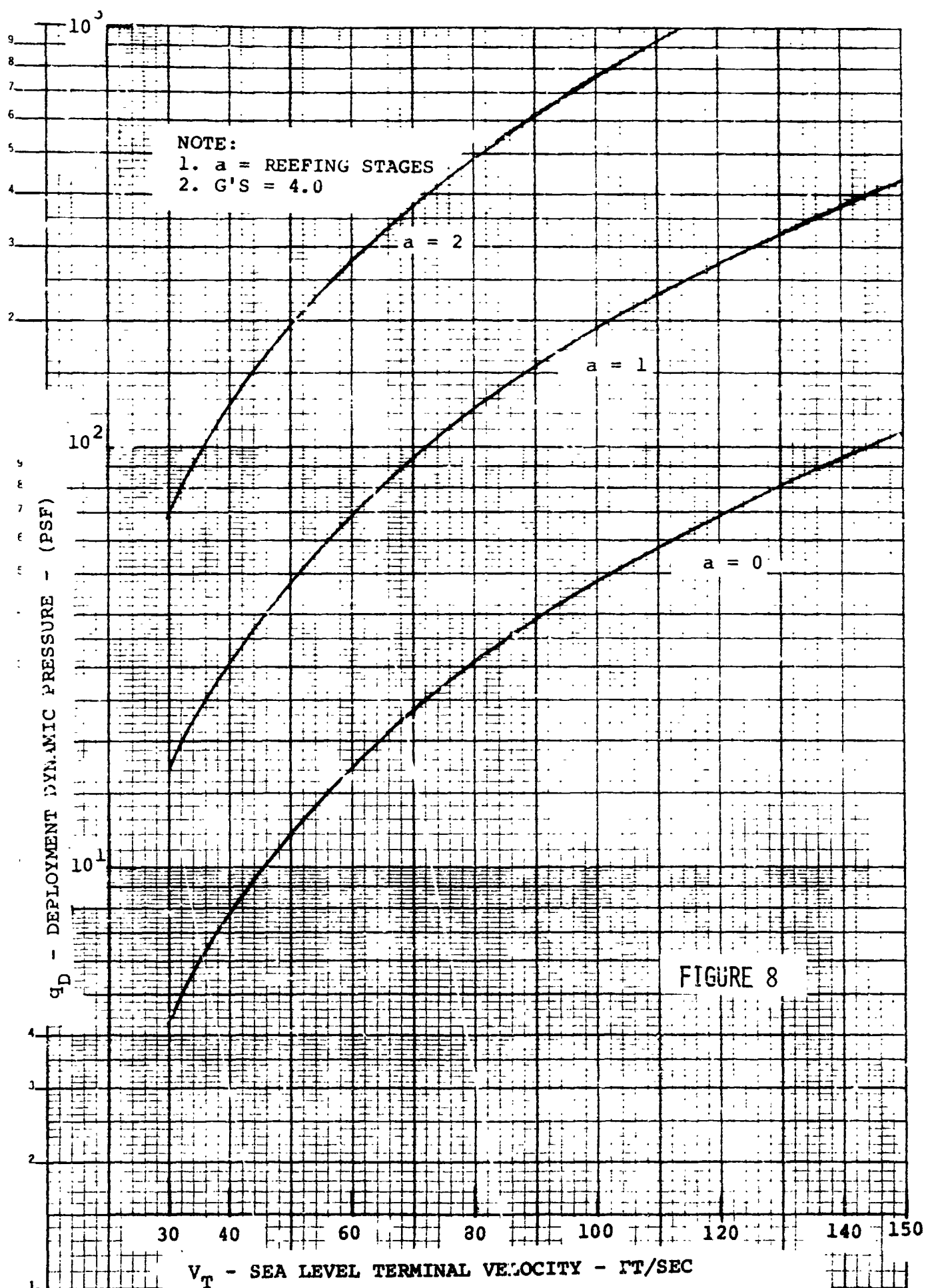

FIGURE 8

FIGURE 8 - DEPLOYMENT q VERSUS TERMINAL VELOCITY FOR 4.0 G'S DECELERATION

f = an efficiency factor that modifies the performance of a single parachute when operating in a cluster, and

C_{D_0} = the parachute nominal drag coefficient when operating as a single parachute

The primary aerodynamic performance characteristics (C_{D_0}) at terminal conditions representative of the main stage parachutes are shown in Figure 9. Only those parachute types which are applicable to the SRB recovery requirements are shown. At the present time, it appears that the 20 degree conical ribbon or ring-slot are the most promising candidates. Even though the ring sail type has a higher nominal C_{D_0} (which would result in a slight size reduction) it is important to note that the cost of manufacturing resulting from performance sensitivity to tolerance, presently eliminates it from evaluation consideration when reuse is considered. In addition, because of the approach to obtaining the deceleration loads in the computer program, sensitivity to parachute type is not significant.

The cluster efficiency η which is a measurement of the net drag performance of parachutes when operating in a cluster is presented in Figure 10 for a variety of configurations which have been previously tested. Based on analysis conducted at GAC, a typical performance estimate has been established and is shown in Figure 10. The specific values for this estimate for N parachutes is shown in Table I.

TABLE I - CLUSTER EFFICIENCY FACTORS

<u>N</u>	<u>f</u>
1	1.0
2	.94
3	.90
4	.89
5	.88
6	.865
7	.855
8	.845
9	.835

Equation 4 has been evaluated for $V_T = 30$ to 150 ft/sec for weights from 150,000 to 300,000 pounds for $N = 3, 6,$ and 9 . This data is shown in Figures 11, 12, and 13 from which parachute diameter can be obtained directly. It is important to state that the parachute size should not be greater than 200 feet and the reasonable maximum size is approximately 135 feet with a limit for this number of parachutes being nine(9). For N other than these values, D_0 can be obtained directly from Equation 4.

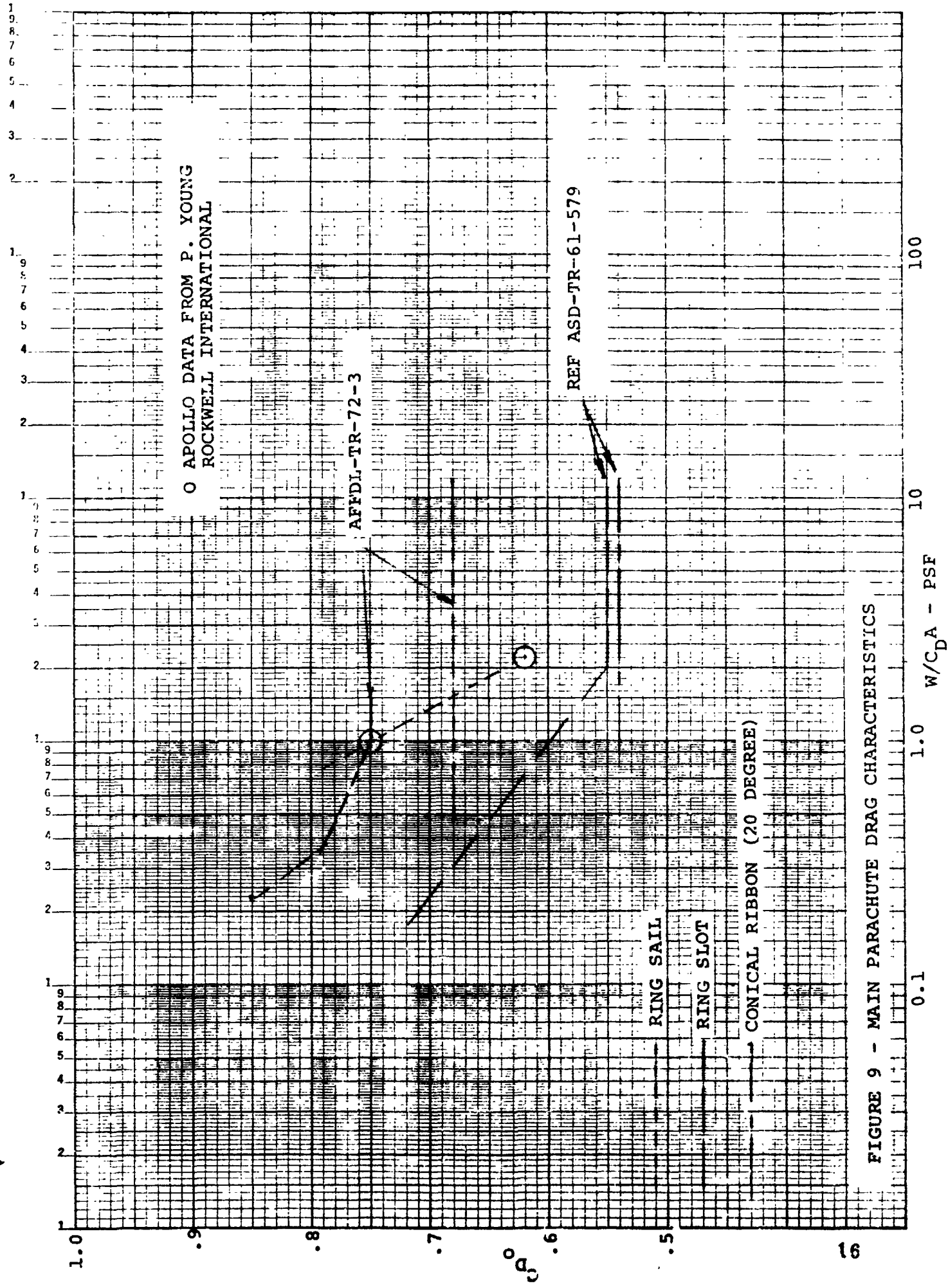
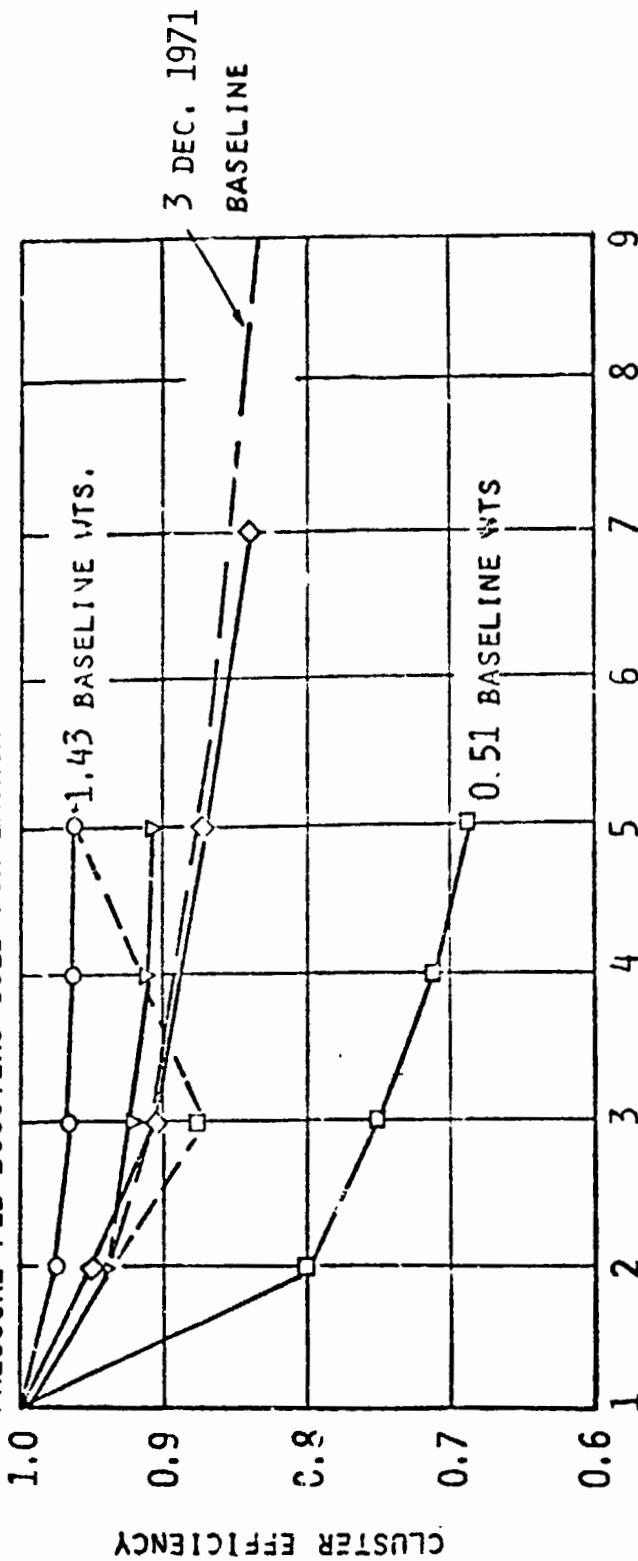

FIGURE 9 - MAIN PARACHUTE DRAG CHARACTERISTICS

REF: RSE 20221-43 FINAL REPORT - RECOVERY SUBSYSTEM CHARACTERISTICS FOR THE CHRYSLER CORPORATION TWIN ELEMENT, PRESSURE FED BOOSTERS USED FOR LAUNCHING THE SPACE SHUTTLE SYSTEM



NUMBER OF PARACHUTES

REF. - RAE TN AERO 1511, D₀ = 2.86 FT

- RISER - 1.4 D₀, L_S = 0.7 D₀
- ▽ RISER - 0.7 D₀, L_S = 0.7 D₀
- RISER - NONE, L_S = 0.7 D₀

REF. - ASD TDR 63-159, D₀ = 2.0 FT

- ◇ RISER - .5 D₀, L_S = 1.0 D₀

WIND TUNNEL

PARACHUTE DROPS FROM 1800 FT ALT; 140 WTS UP TO 50,000 LB PAYLOAD

REF - FTC TR-69-35, D₀ = 135 FT

- RISER - 1.25 D₀, L_S = 1.00 D₀

PARACHUTE CLUSTER EFFICIENCY

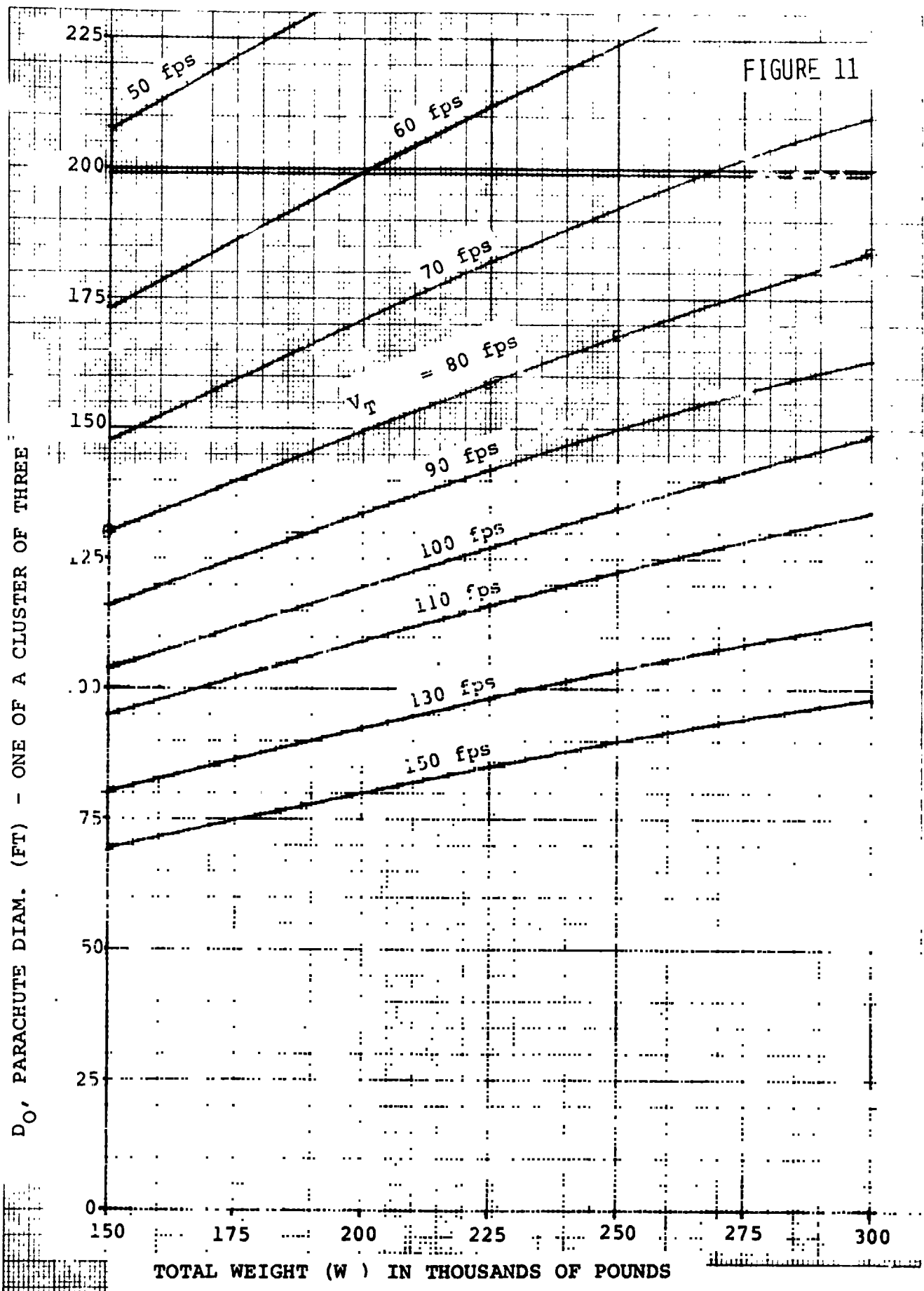

FIGURE 11

FIGURE 11 - PARACHUTE DIAMETER VERSUS TOTAL WEIGHT FOR 3 PARACHUTES

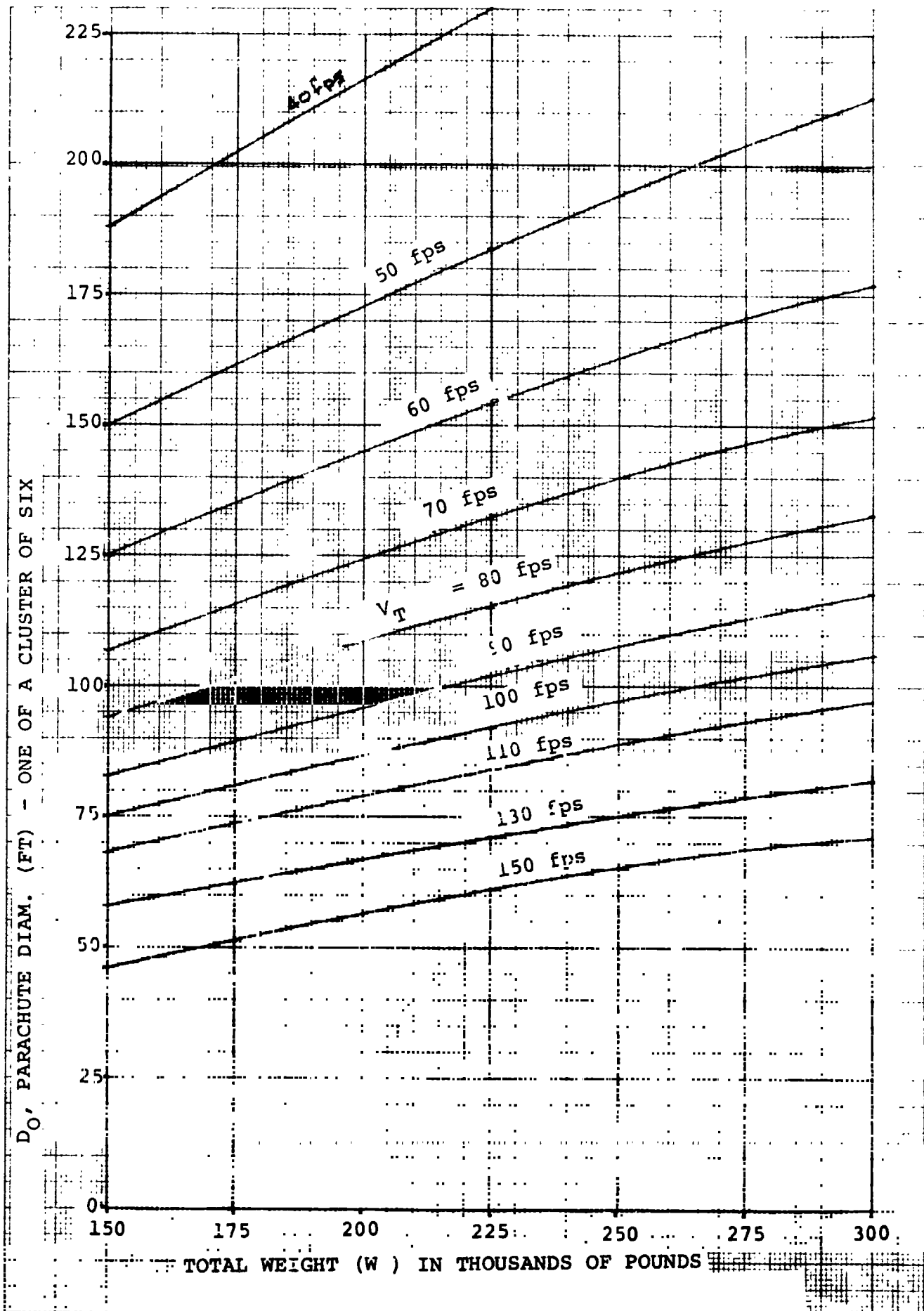

FIGURE 12 - PARACHUTE DIAMETER VERSUS TOTAL WEIGHT FOR 6 PARACHUTES

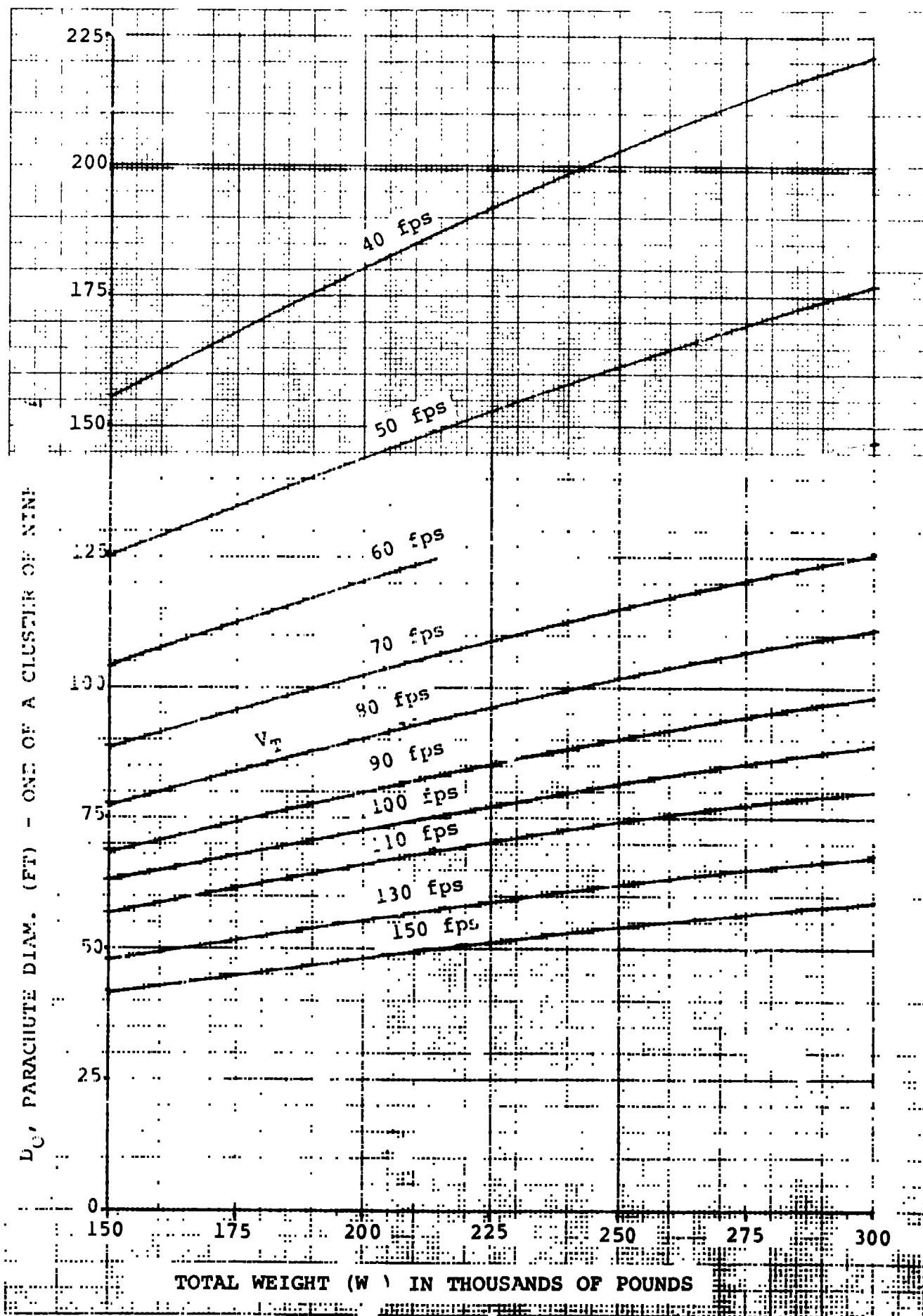

FIGURE 13 - PARACHUTE DIAMETER VERSUS TOTAL WEIGHT FOR 9 PARACHUTES

RISERS

Parachute drag performance is dictated by two criteria. For single or clustered canopies, it is necessary to place the leading edge of the parachute (canopy skirt) at a distance approximately 6.5 times the base diameter (max diameter) of the SRB. The riser length required is therefore

$$L_R = 6.5(D_{SRB}) - L_S \quad (5)$$

where: L_R = riser length, m (ft)

D_{SRB} = Diameter of SRB Base, m (ft)
 L_S = suspension line length = $1.5 D_0$, m (ft)

In addition to wake performance factors, to achieve proper cluster efficiency, a riser can be required to insure optimum parachute clustering. The relative riser length is dependent on the number of parachutes in the cluster. The actual length is then dictated by the parachute size. The primary amount of data which exists in this area is contained in the Engineering Design Handbook - AMCD-706-130 for U.S. Army aerial delivery systems. Data from this report has been summarized in Figure 14. When the parachute suspension line length is 1.5 times the D_0 , the relative riser length as a percent of the parachute D_0 can be obtained directly when the number of parachutes is known. For purposes here, it should be assumed that each parachute has its own riser. (The case could exist when 6 or 9 parachutes are considered that a single riser could connect a group of three parachutes together. This technique will not be pursued in this manual but possible future recovery analysis could result in this approach).

TETHER

A tether for the parachute system can be required for several reasons. For cases where a single attachment point on the SRB will serve as the load transfer point and it is not practical to terminate the individual risers or parachute confluence directly to the SRB a tether would serve as this interface. A similar example would be for attachment to the confluence of the bridle. For these cases, the tether would be of a minimal length. The maximum tether length for performance consideration is dictated for the case when additional length is required to achieve the condition of the parachute leading edge being 6.5 diameters aft. For this case the tether length is

$$L_T = (6.5)(D_{SRB}) - (L_S + L_R) \quad (6)$$

where

L_T = length of tether, m (ft)

D_{SRB} = Diameter of SRB; m (ft)

L_S = Parachute Suspension Line Length; m (ft)

L_R = Length of riser - m (ft)

1. REF AMCP 706-130

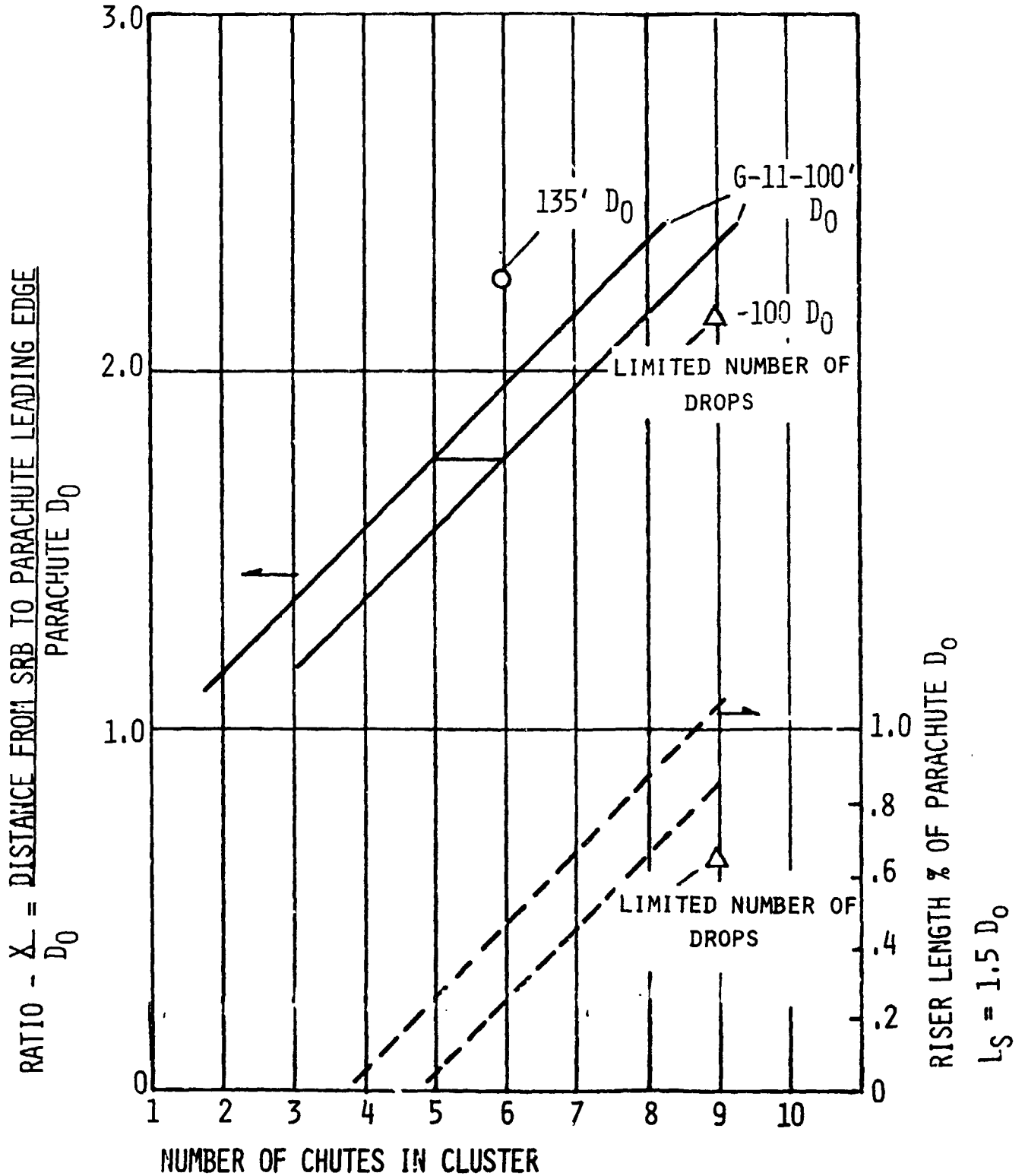

FIGURE 14 - RISER LENGTH CRITERIA FOR PARACHUTE CLUSTERS

BRIDLE

At times, it becomes necessary to attach the parachute systems to the SRB by what is referred to as a bridle. This bridle is generally comprised of 2, 3, or 4 legs which are located on the SRB. For purposes of analysis in this model, the bridle can only have two legs. A typical representation is shown in Figure 15 and as described in the program users manual (GER-15853) the attachment points are located as x, y coordinates on the SRB and each leg is described by its length. The computer program then determines the intersection point or confluence of the two legs.

In the event that a single attachment point is desired the bridle input is still required but the separation distance between each leg should be 0.5 inches and the length of each leg should equal 0.5 inches.

The length of the bridle legs is dependent on a variety of design factors. Since the particular requirements of the bridle are not as yet known to GAC, the subject of length and strength will not be discussed herein, but will be left up to MSFC personnel. (The actual strength cannot be established until the computer runs are conducted.) Preliminary estimates can be made based on the desired peak deceleration rate.

5. Calculate Parachute System Weight

General

Presented in the previous subsection was the method for determining size requirements for the major components of the main parachute system. As noted, the sizing of the various components is dependent on the total weight of the descending system. Since this is the case, in determining sizing values, an iterative process is required which begins with assumed values for certain parameters, and then progress through a direct calculation of the values. A comparison is then made to the assumed and depending on the magnitude of the difference between the assumed and calculated, a second iteration is required. This iteration begins with the calculated value from the previous step and proceeds. When the assumed and calculated are within a parachute diameter difference of approximately 0.5 feet assume this to be accurate enough.

In general, the total descent weight (W) can be written as:

$$W = W_{SRB} + W_T + W_P + W_B \quad (7)$$

where

W = total descent weight, N (lbs)

W_{SRB} = weight of the basic SRB and any recovery system components remaining with it, N (lbs)

W_T = weight of the tether, N (lbs)

W_P = weight of the parachutes, N (lbs)

W_B = weight of the bridle, N (lbs)

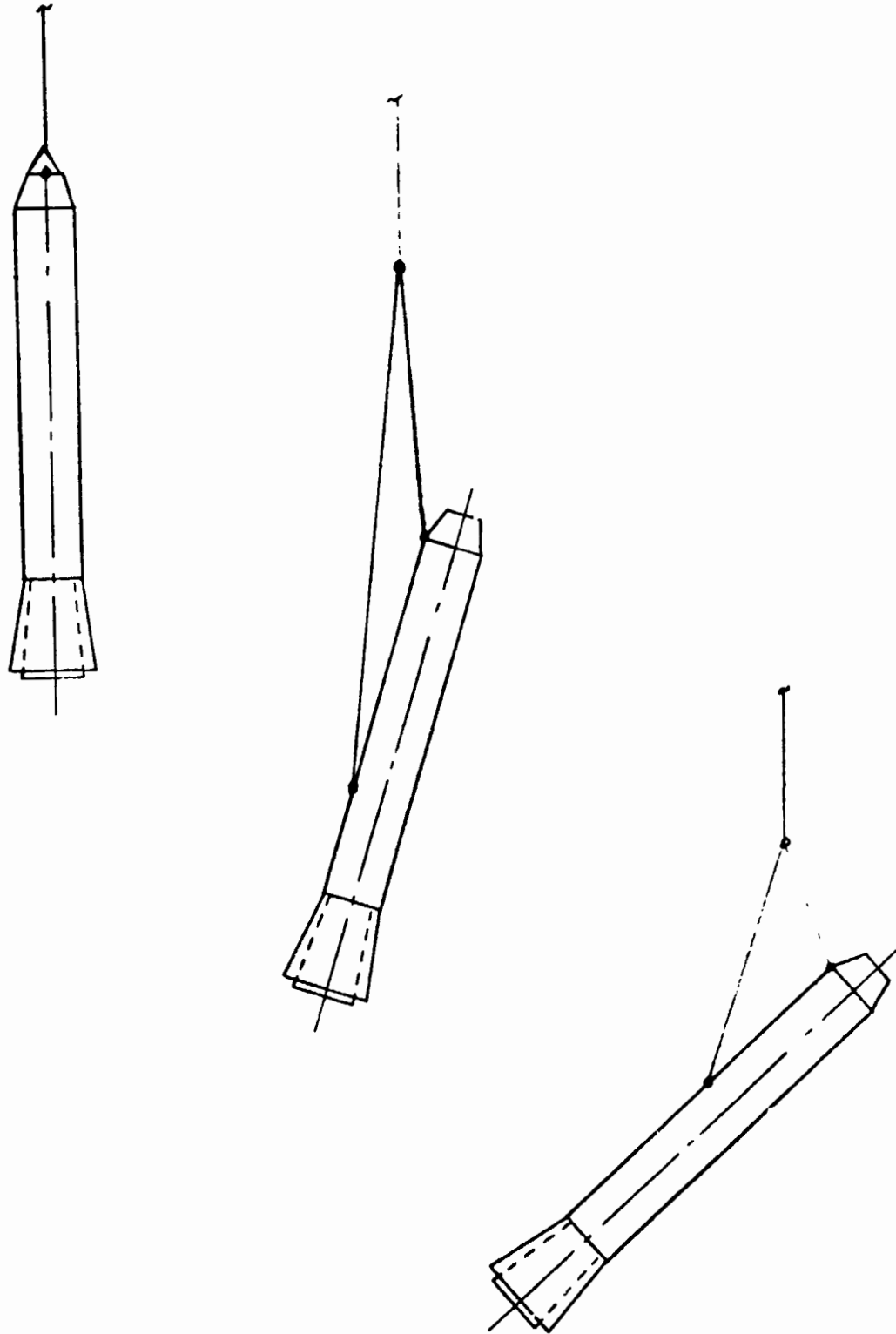

FIGURE 15 - GENERAL BRIDLE ARRANGEMENTS

PARACHUTE WEIGHT

Experience has shown that the primary contributor to the total weight is that of the SRB. The second highest is that of the parachutes, with the riser, tether, and bridle being relatively small.

In terms of several parameters, the weight of the parachutes can be shown to be equal to

$$W_P = (F_{LP}) (G's) (D_o) (W) \left[\left(\frac{(D.F.) (C.F.) L_s/D_o}{K_L} \right) + \text{Lines} \right] \left(\frac{(.168) (D.F.)_c (C.F.)_c C_{P_o}}{C_{D_o'}} \frac{A}{S_o} \right) \quad (8)$$

canopy

where

W_P = weight of (N) parachute of diameter D_o N (lbs)

W = total weight = suspended weight + parachute weight

G's = deceleration system load factor

D_o = nominal parachute diameter, meters (feet)

F_{LP} = Factor to allow for overload of leading parachute = 1.5

(D.F.) = overall design factor for suspension lines including a margin of safety of 2.0 = 2.5

(D.F.)_c = overall design factor for canopy including a margin of safety of 2.0 = 2.5

(C.F.) = construction factor for suspension lines = 1.05

(C.F.)_c = construction factors for canopy seams, overlaps, thread, and reinforcing = 1.3

L_s/D_o = ratio of parachute line length to parachute nominal diameter = 1.5

C_{P_o}/C_{D_o} = ratio of local (maximum) canopy pressure coefficient to nominal drag coefficient = 2.0

A/S_o = ratio of cloth area in canopy to nominal area = .85

K_L = strength to weight ratio for suspension line material = 1.73×10^5 ft. for nylon

K_c = strength to weight ratio for canopy material = 8.72×10^4
ft for nylon

After substituting these values into Eq (6) the weight of the parachute is:

$$W_p = 5.55 \times 10^{-5} (D_o) (G's) (W) \quad (9)$$

This equation has been developed at GAC for parametric analysis purposes and hold true when optimum gauge materials are considered. For cases when a minimum gauge is applicable a component weight analysis would be required. Because of the relative complexity of this type of analysis and the fact that the parachute weight has a minimal affect on the deceleration loads, it is reasonable to use Equation 7 for purposes here.

RISER AND TETHER WEIGHT

For the cases where either a riser or tether is required, their weight can be obtained from:

$$W_R = (D.F.) (W) (G's) \left(\frac{L_R}{K} \right) \quad (10)$$

where

D. F. = Design factor = 2.5

K = Strength to weight ratio for riser material
(nylon; 1.73×10^5 ft)

L_R = Riser length; m (ft)

For the case when the tether is being considered L_R becomes L_T and the same equation applies. In the event that each parachute in the cluster has its own individual riser, and since the possibility exists that a leading parachute could see an overload factor of 1.5 (F_{LP}), then this factor must also be employed in the equation. If a riser is attached to more than one parachute then this factor would not be applicable. Similarly, tether weight would not require this factor.

BRIDLE WEIGHT

As previously mentioned, because of a variety of considerations which must be considered in establishing bridle requirements which are presently not known to GAC, this subject will not be analyzed herein. The only comment which would be applicable is that a preliminary estimate for bridle weight could be obtained from Equation 8 when the individual lengths of each leg are known, and an estimate for the design load $[(W)(G's)]$ can be made. In the event that a particular material gauge is selected then the weight could be calculated based on its weight per unit length.

6. Example Problem

To best show the methodology, it is appropriate at this point to present an example problem and walk through the steps of establishing the sizing and weights of the various components.

For this example assume $W_{SRB} = 170,000$ Lbs, the desired terminal velocity $V_T = 80$ (Ft/Sec) and the peak load factor is 3.0.

From Equation (5) a weight for the parachutes W_P is required. An initial estimate for W_P can be obtained from Figure 15A as a percentage of SRB weight when the descent velocity and deceleration load factor are known. The data of this figure will serve as a reasonable preliminary estimate and was generated from results of previous SRB recovery analysis conducted at GAC. For the above conditions, $W_P/W_{SRB} = .030$.

Since riser tether and bridle weight cannot be evaluated until a second iteration when their lengths can be evaluated, Equation 5 reduces to

$$W = W_{SRB} + W_P = W_{SRB} + .030 W_{SRB}$$

$$W = (1.030)(170,000)$$

$$W = 175,100 \text{ Lbs}$$

The parachute diameter required can now be obtained from Figure 11, 12, or 13. For a three, six and nine parachute cluster, the diameters would be 140, 102 and 84 feet respectively. Since the 140 foot diameter is not too much greater than the desired 135 feet, a three parachute cluster will be assumed. From Figure 14 no riser will be required, but for interface purposes, a 15-foot tether will be assumed. From Equation 10 the tether weight would be

$$W_T = 1.44 \times 10^{-5} (175,100)(3.0)(15)$$

$$W_T = 113.4 \text{ (lbs.)}$$

The actual parachute weight from Equation 9 will be

$$W_P = 5.55 \times 10^{-5} (140)(175,213)(3.0)$$

$$= 4090 \text{ (lbs.)}$$

The total system weight for the first iteration becomes:

$$W = W_{SRB} + W_P + W_T + 170,000 + 4090 + 113$$

$$W = 174,203 \text{ (lbs.)}$$

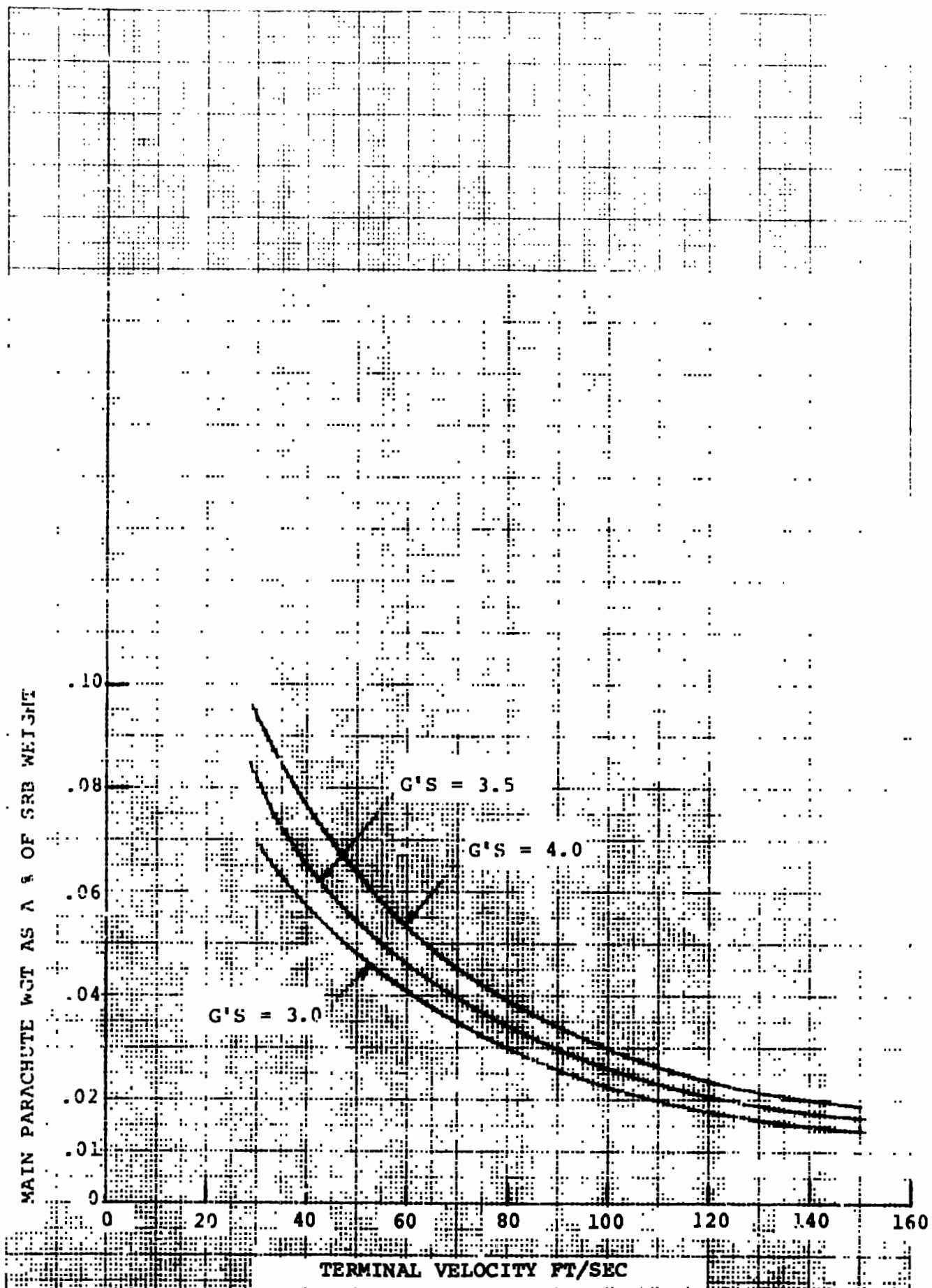

FIGURE 15A - RELATIVE MAIN PARACHUTE WEIGHT
VERSUS TERMINAL VELOCITY

Referring back to Figure 11 , the new parachute diameter would be 139.6 feet.

The next iteration on weight would start with

$$W_P = 5.55 \times 10^{-5} (139.6)(174,203)(3.0)$$

$$W_P = 4050 \text{ (lbs.)}$$

and

$$W_T = 1.44 \times 10^{-5} (174,203)(3.0)(15)$$

$$= 112.8 \text{ (lbs.)}$$

or

$$W = 170,000 + 4050 + 112.8$$

$$= 174,163 \text{ (lbs.)}$$

Since this is almost identical to the previous weight, assume this value to be identical and work the balance of the problem based on these values.

$$W = 174,163 \text{ Lbs}$$

$$W_P = 4050 \text{ Lbs}$$

$$W_T = 112.8 \text{ Lbs}$$

$$SSRB = 170,000 \text{ Lbs}$$

$$D_0 = 139.6 \text{ Ft}$$

$$N = 3$$

$$a = 2$$

$$L_T = 15 \text{ Ft}$$

$$G's = 3.0$$

$$q_D = 203 \text{ PSF}$$

7. Select Deployment Conditions, Inflation Times, and Reefing Times

DEPLOYMENT CONDITIONS AND INFLATION TIMES

Selection of the deployment conditions (altitude, velocity, flight path angle) for the main parachutes is dependent on several considerations. These include the deployment dynamic pressure, peak deceleration rate, parachute inflation time, parachute reefing time, and the trajectory flight path angle. In addition to these, the deceleration trajectory for the drogue stage also comes into play. In general, the solution is obtained by performing a series of point mass deceleration trajectories, establishing a variety of cross plots, and selecting conditions which are compatible with satisfying the requirements while providing a minimum weight system. Because of the nature of this manual, the methodology which is presented herein is not intended to provide this optimization capability but instead will provide basic conditions for selecting inflation times and reefing times.

The starting point for this task is to assume a deployment altitude, define the velocity compatible with the deployment dynamic pressure, establish parachute inflation time, select reefing time, and altitude loss. This then gives the start conditions at disreef of the first stage and in turn the start conditions for the inflation of the second stage of main parachute deceleration. Similarly, this process is repeated for the second stage to get the approximate conditions for second disreef and inflation to the full open parachute.

The velocity at the time of deployment can be readily obtained once the deployment altitude is known and the dynamic pressure defined. Based on a variety of work conducted at GAC, it appears that the main parachutes can be at altitudes less than 10,000 feet. For initial purposes, assume this as the starting point. For $q_D = 203$ PSF, the corresponding velocity (V_D) at 10,000 feet is 481 ft/sec.

For preliminary purposes, the filling time for the parachute can be obtained directly from Figure 16 when the diameter and velocity are known. The velocity shown in this figure is referred to as snatch velocity which is defined as the velocity of the total system just as the parachute is completely stretched out. For purposes here, this will be assumed to equal the velocity at deployment or disreef. The diameter of the parachute used in the figure is that of its nominal diameter or D_0 . For the conditions when the parachute is reefed, an equivalent reefed D_0 must be developed. Presented on the figure are three inflation curves for DESIGN, MEAN and PERFORMANCE considerations. For calculating loads, the DESIGN curve should be used and for altitude loss during decelerations the PERFORMANCE curve should be used.

The equivalent D_0 for the reefed parachute is obtained by defining the drag area of the particular stage, and then determining its nominal reference area, and then calculating the diameter of the equivalent area. For the example which we previously discussed, a cluster of 3; 139.6 feet diameter parachutes was chosen. The total drag area of the full open cluster is

$$\begin{aligned} (C_D A)_T &= N \eta C_{D_0} A_0 \\ &= (3)(.90)(.55)(\pi/4)(139.6)^2 \end{aligned} \quad (11)$$

$$(C_D A)_T = 22700 \text{ Ft}^2$$

The $C_D A$ for one parachute is:

$$\begin{aligned} (C_D A)_1 &= \frac{(C_D A)_T}{3} \\ &= 7566 \text{ ft}^2 \end{aligned} \quad (12)$$

The $C_D A$ of each of the stages of reefing can be obtained similarly to the method of Equation 3 or

FROM: ASD-TR-61-579
FIG 4-49 & 4-50

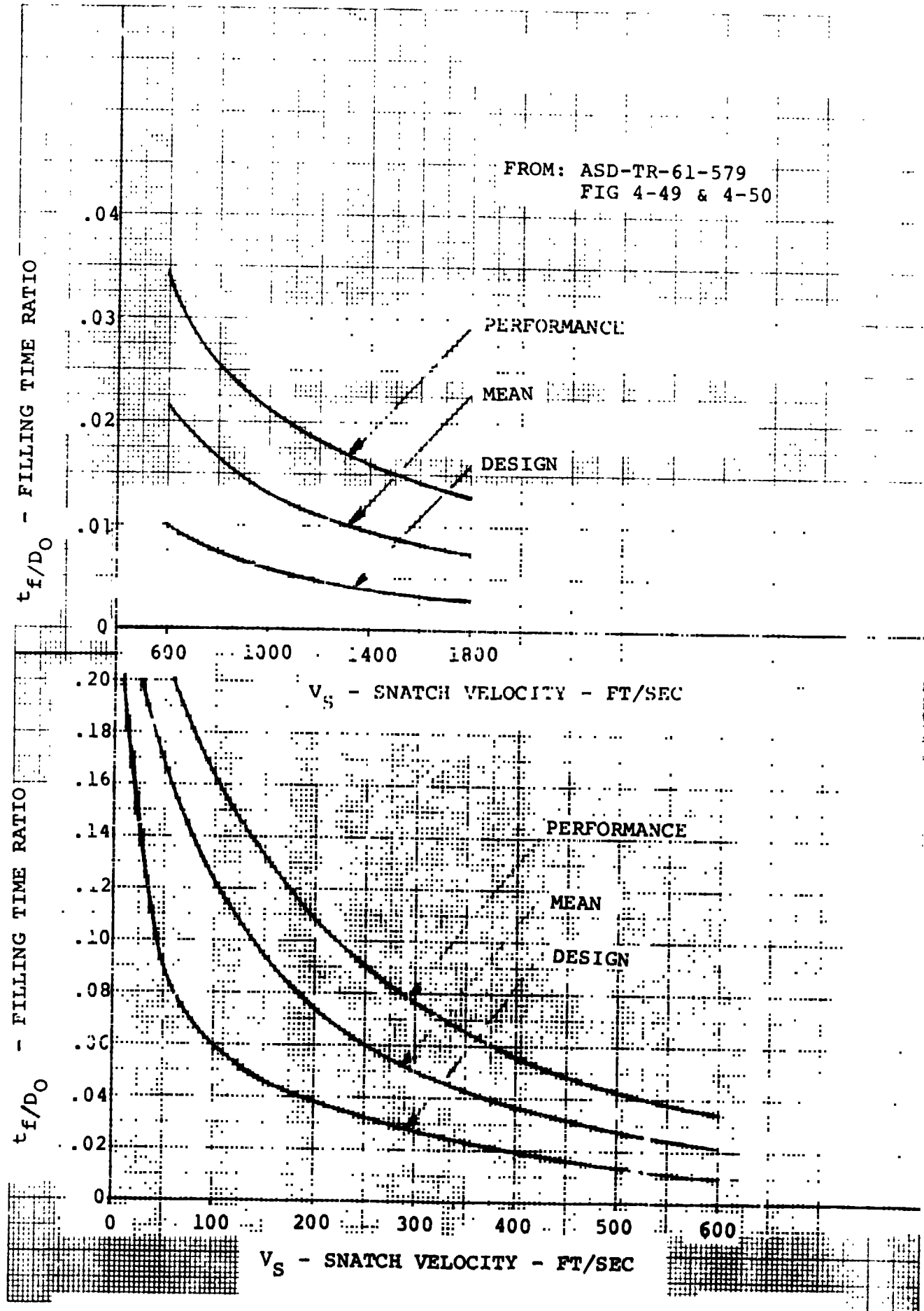

FIGURE 16 - FILLING TIME t_f/D_0 RATIO VERSUS SNATCH VELOCITY

$$(C_{DA})_a = \frac{(C_{DA})_T}{(G's)^a} \quad (13)$$

where:

$(C_{DA})_a$ = $C_D A$ of stage a where a can equal 1 or 2, $m^2(ft^2)$

$(C_{DA})_T$ = total $C_D A$ of all parachutes in the cluster, $m^2(ft^2)$

a = number of reefed stages and equals 1 for the second stage, and 2 for the first stage

also

$$(C_{DA})_a = (N)(\eta_a)(C_{DR})(A_R) \quad (14)$$

where

C_{DR} = drag coefficient for a single reefed parachute

A_R = nominal area of a single reefed parachute, $m^2(ft^2)$

$$A_R = \frac{\pi}{4} D_R^2$$

D_{R_a} = nominal diameter of a single reefed parachute of stage a,
 $m(ft)$

η_a = cluster efficiency for the particular reefed stage

or Equations 13 and 14 can be transposed to

$$D_{R_a} = \left[\frac{(4)(C_{DA})_T}{\pi(G's)^a(N)(\eta_a)(C_{DR})} \right]^{1/2} \quad (15)$$

and if Equation 11 is substituted for $(C_{DA})_T$, Equation 15 becomes

$$D_R = D_o \left[\frac{(\eta)(C_{D_o})}{(G's)^a(\eta_a)(C_{DR})} \right]^{1/2} \quad (16)$$

If for preliminary purposes, it is assumed that $\eta_a = \eta$ and $C_{DR} = C_{D_o}$ then Equation (16) reduced to

$$D_{R_a} = \frac{D_o}{[(G's)^a]^{1/2}} \quad (17)$$

From our example,

$$D_{R1} = \frac{139.6}{[(3^2)]^{1/2}} = \frac{139.6}{3} = 46.5 \text{ ft.}$$

and

$$D_{R2} = \frac{139.6}{(3^1)^{1/2}} = 80.4 \text{ ft.}$$

From Figure 16 the inflation time for the parachute at a deployment velocity of 481 ft/sec at 10,000 feet,

$$\begin{aligned} t_f/D_0 &= .0142 \quad \text{DESIGN} \\ &= .0445 \quad \text{PERFORMANCE} \end{aligned}$$

Using the PERFORMANCE value, the filling time is

$$t_f = (.0445)(46.5) = 2.07 \text{ seconds}$$

In order to determine if sufficient altitude is available to achieve deceleration and also select the initial conditions for disreef of the first stage, and eventually the second stage, a series of point mass trajectories were run to establish this for various inflation times, at various deployment (or disreef q's) at various altitudes at a flight path of -90° and 3G's deceleration. (These latter conditions were selected as worst case conditions and primary emphasis placed there.) In addition, the affects of 4.0 G's deceleration and a flight path of -70° were also considered to establish these affects.

The results of the 3 G decelerations are presented in Figures 17 thru 25 for inflation times from 1 second thru 24 seconds. These plots are shown as the altitude loss at 95% of q_T as a percent of initial altitude versus initial altitudes. The 95% value was selected since it was found that at these very low deceleration rates the terminal velocity was only obtained for deployment q's less than approximately 40 PSF. In addition, it is also known that because of the q deploy during the inflation process that the peak deceleration force achieved from $F = qC_D A$ will not exceed (W) X (G's) except possibly when going to fall open.

Here again, the methodology presented here is to provide a "first pass" approach to establishing these parameters and is not intended as final design criteria since many iterations will be required to accomplish this.

In addition to these plots, Figures 26, 27 and 28 present similar data for 4G deceleration at a flight path angle of -70 degrees for inflation times of 9, 15 and 24 seconds respectively. These figures can serve as end points to be used to assist in interpolation to other initial conditions if desired. If the 3G values are used, relatively conservative estimates will be obtained.

For our example ($t_f = 2.07 \text{ sec}$), Figure 18 will be used ($t_f = 3.0 \text{ sec}$). For the initial q of 203 PSF and altitude of 10,000 feet, the altitude loss can be

FIGURE 17

NOTE:
 1. PEAK G'S = 3.0
 2. $t_c = 1$ SEC
 3. $\theta = -90^\circ$

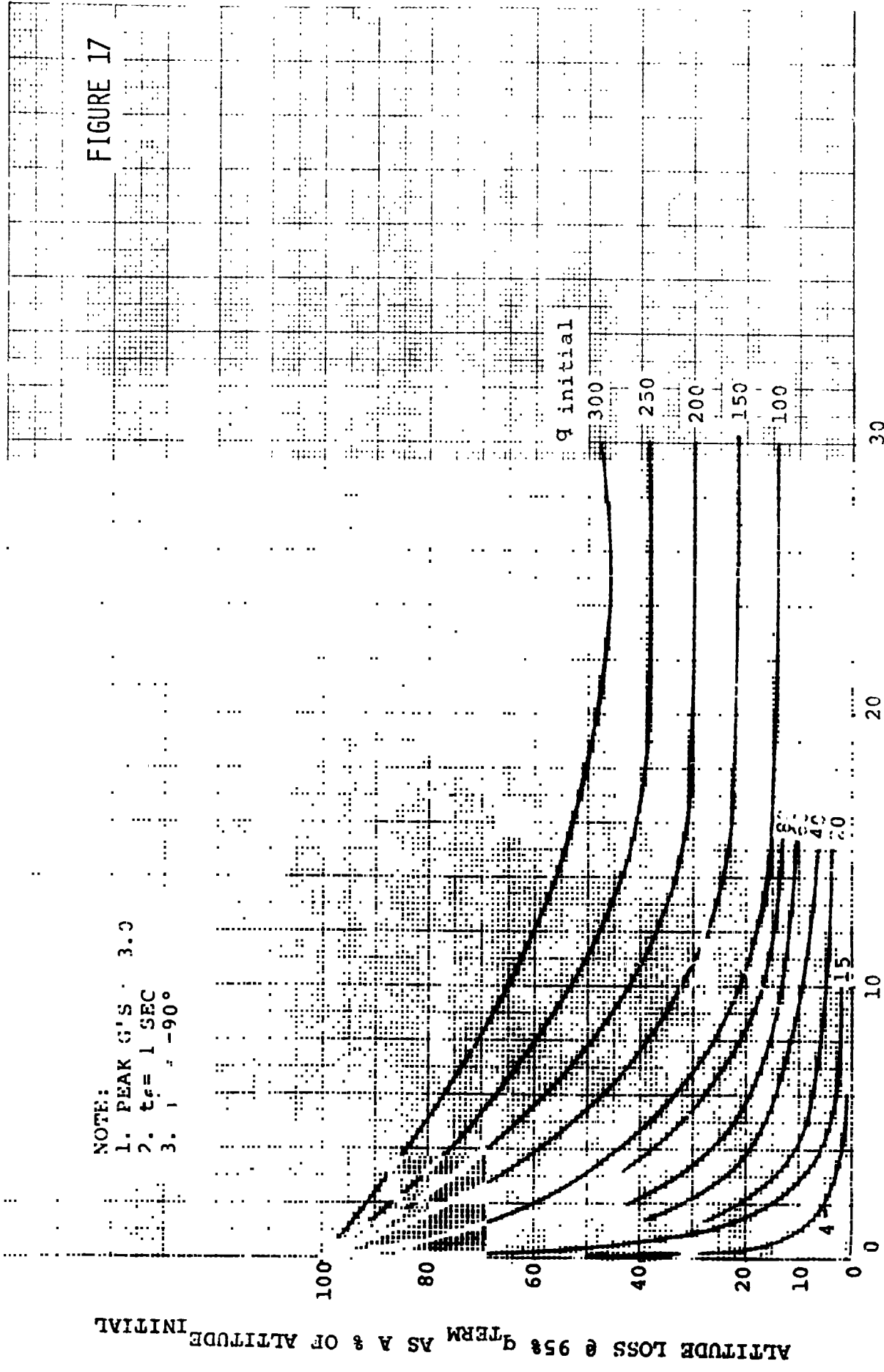

ALTITUDE INITIAL - FT x 10⁻³

ALTITUDE LOSS @ 95% q_{TERM} AS A % OF ALTITUDE INITIAL

ALTIUDE LOSS @ 95% q_{TERM} AS A % OF ALTIUDE INITIAL

- NOTE:
1. PEAK G'S = 3.0
 2. $t_f = 3$ SFC
 3. $\gamma = -90^\circ$

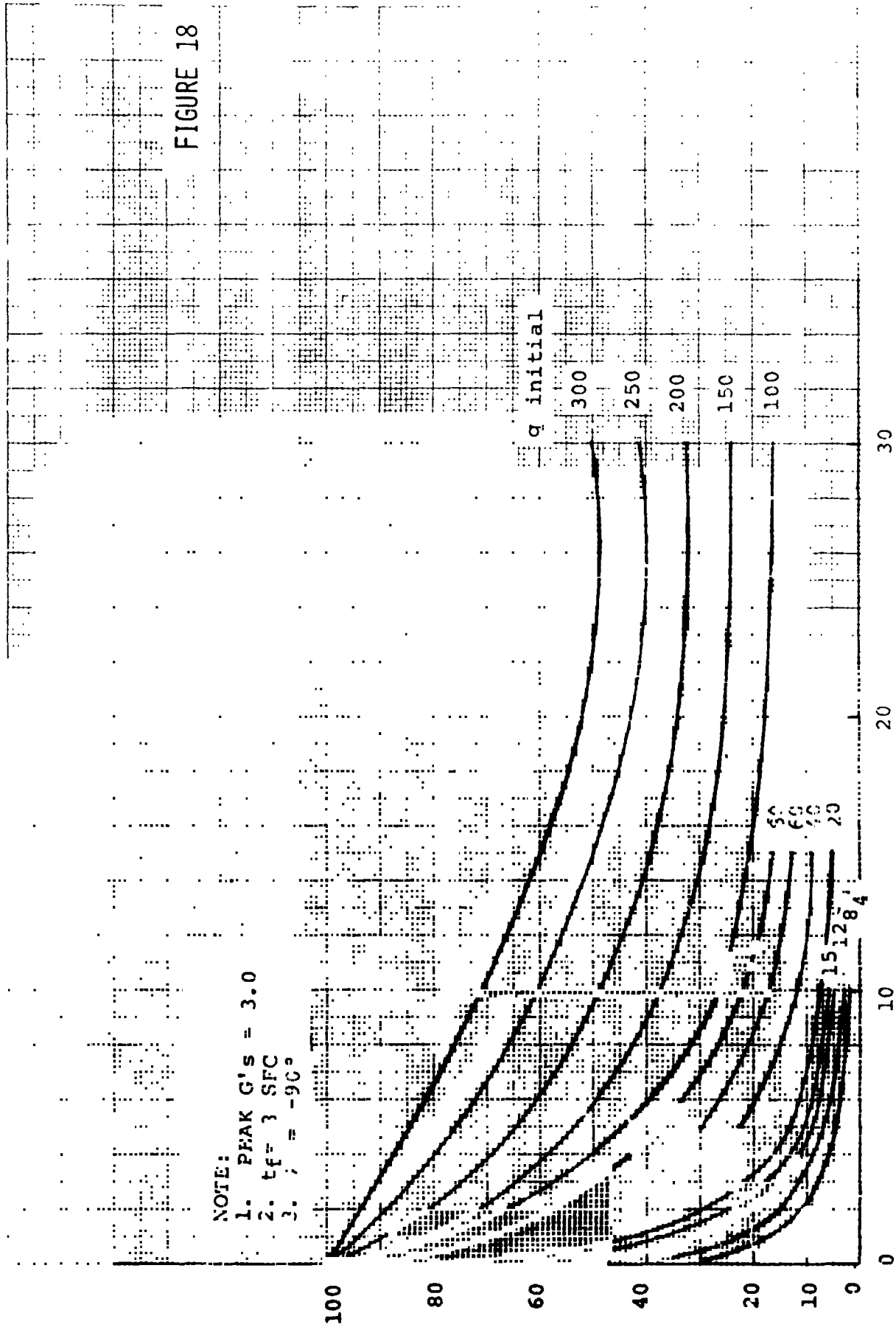

FIGURE 18

ALTITUDE INITIAL - FT x 10^{-3}

ALTIUDE LOSS @ 95% TERM AS A % OF ALTIUDE INITIAL

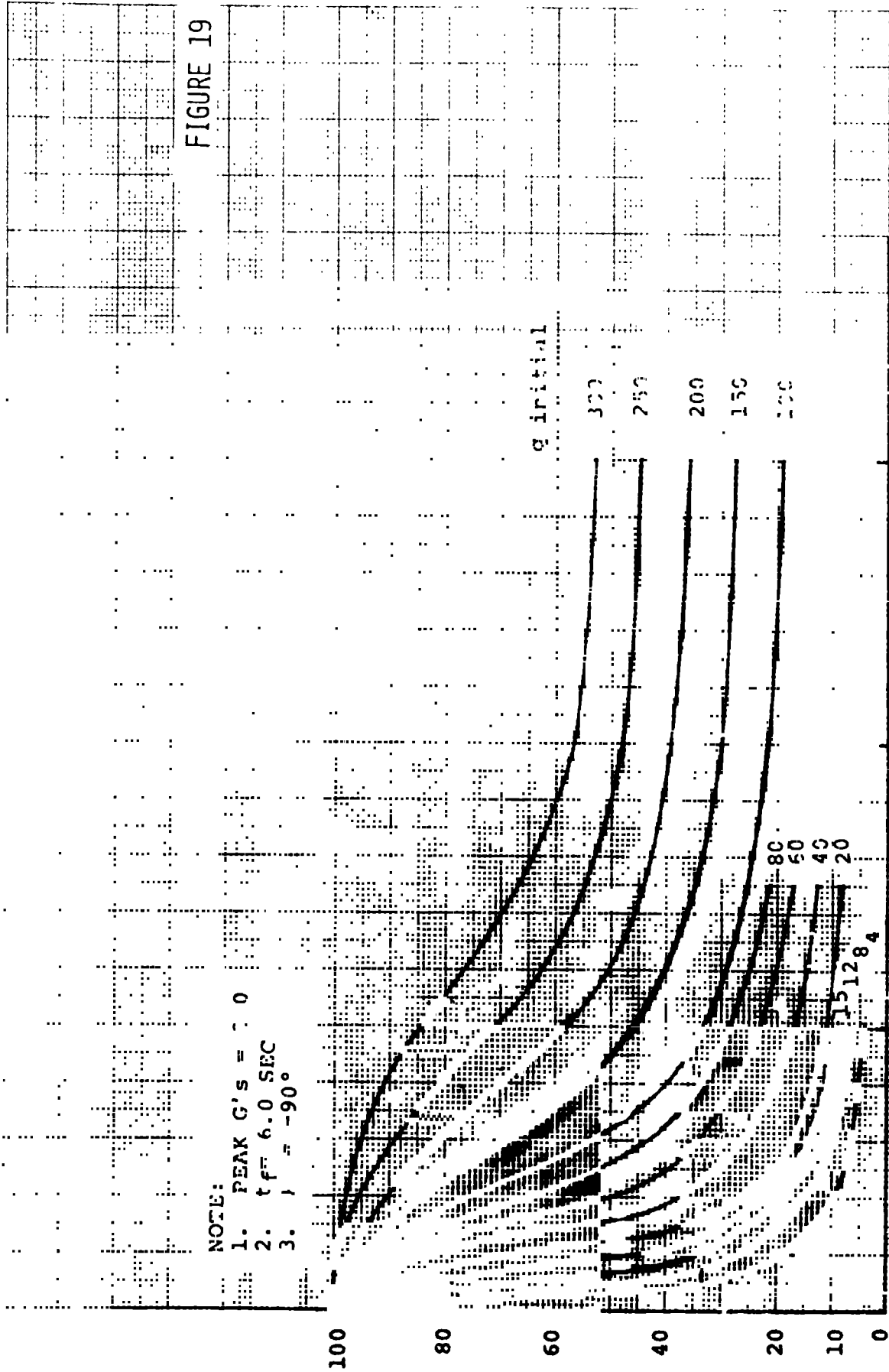

FIGURE 19

- NOTE:
1. PEAK G'S = 0
 2. t_f = 6.0 SEC
 3. γ = -90°

ALTITUDE INITIAL - FT x 10⁻³

ALTTUDE LOSS @ 95% q_{TERM} AS A % OF ALTTUDE INITIAL

- NOTE:
1. PEAK $C'q = 3.0$
 2. $t_f = 1.0$ SEC
 3. $\gamma = -90^\circ$

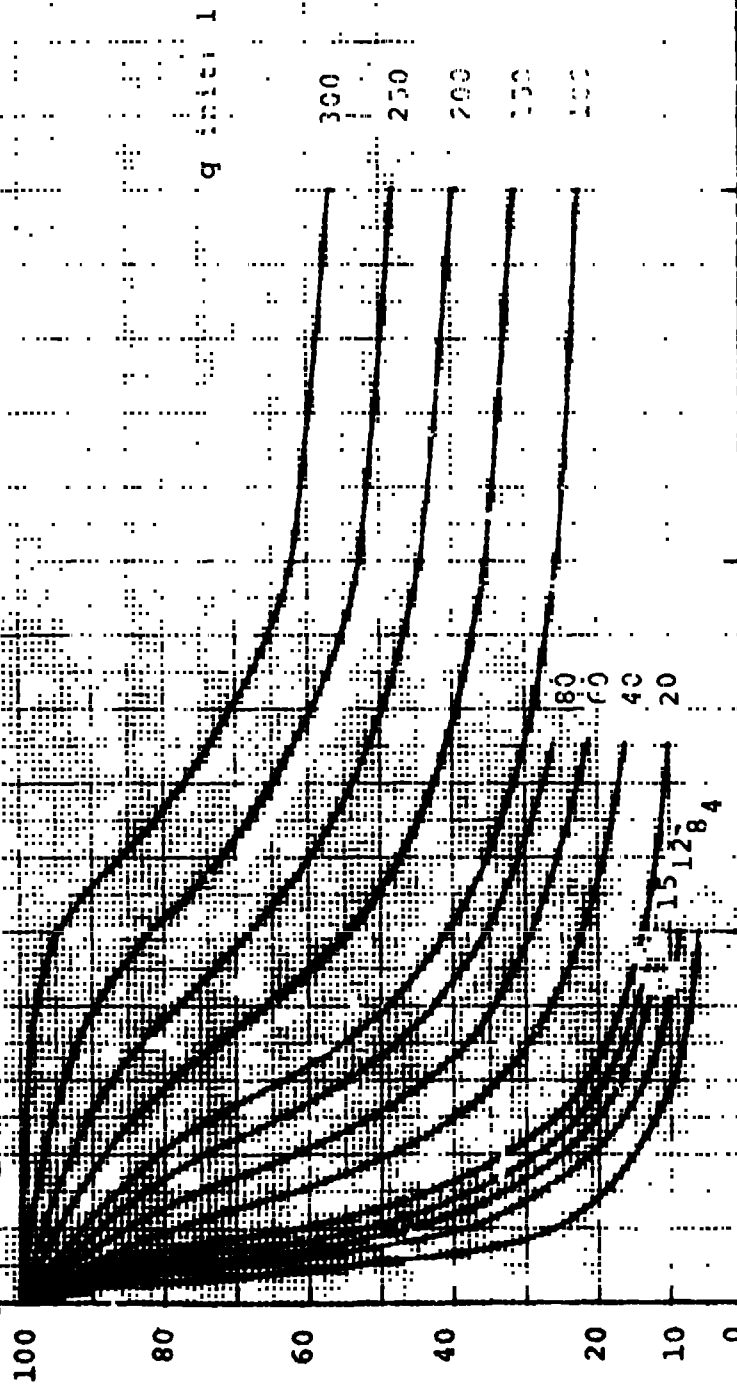
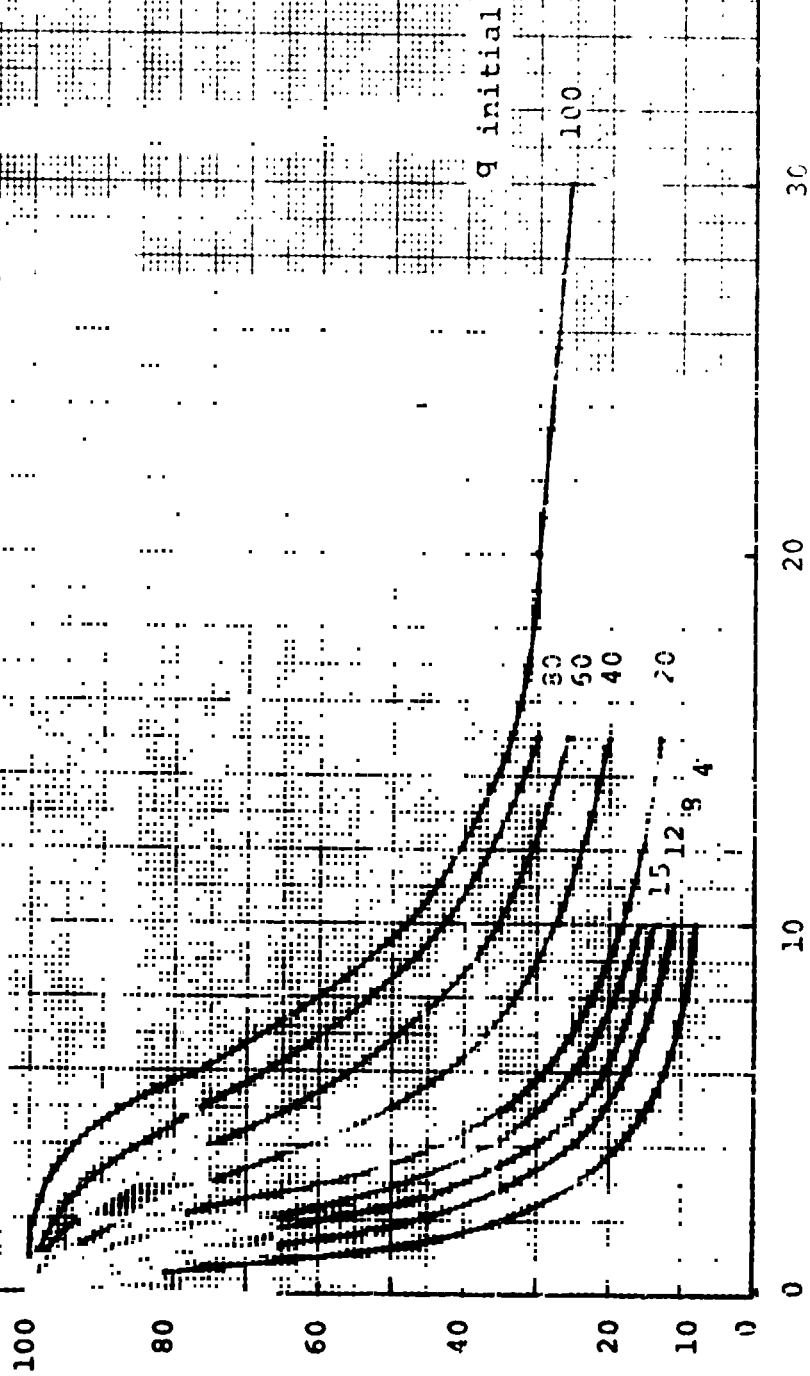

FIGURE 20

ALTIMUDE LOSS @ 95% q_{TERM} AS A % OF ALTIMUDE INITIAL

FIGURE 21

- NOTE:
1. PEAK $G's = 3.0$
 2. $\theta = 2.0$ SEC
 3. $\gamma = -90^\circ$



ALTIMUDE INITIAL - FT x 10⁻³

ALTITUDE LOSS @ 95% q_{TERM} AS A % OF ALTITUDE INITIAL

- NOTE:
1. PEAK G's = 3.0
 2. $t_f = 15.0$ SEC
 3. $\gamma = -90^\circ$

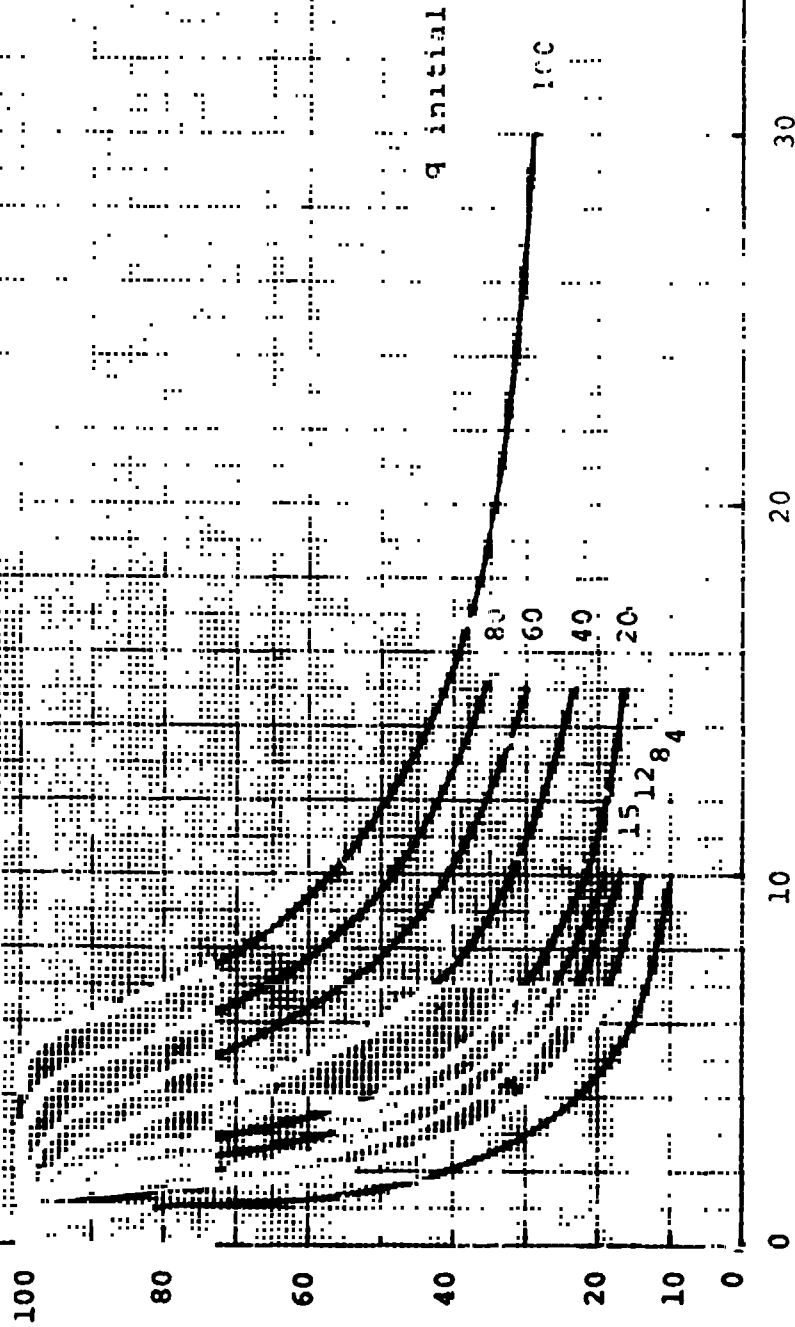

FIGURE 22

ALTIUDE LOSS @ 95% TERM AS A % OF ALTIUDE INITIAL

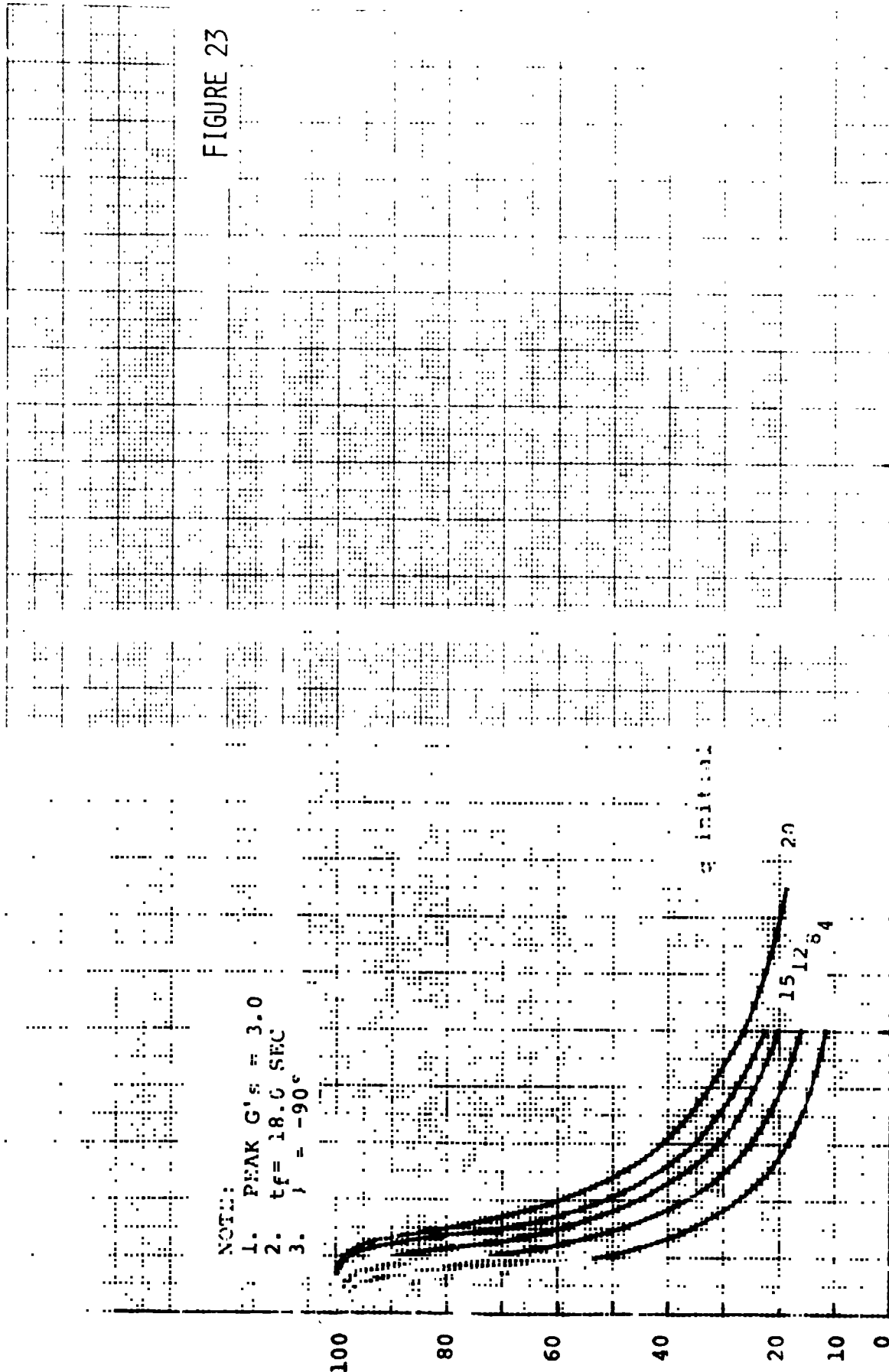

FIGURE 23

ALTIUDE INITIAL - FT x 10⁻³

ALTIUDE LOSS @ 95% q_{TERM} AS A % OF ALTIUDE INITIAL

- NOTE:
1. PEAK G'S = 3.0
2. t_f = 21.0 SEC
3. θ = -90°

FIGURE 24

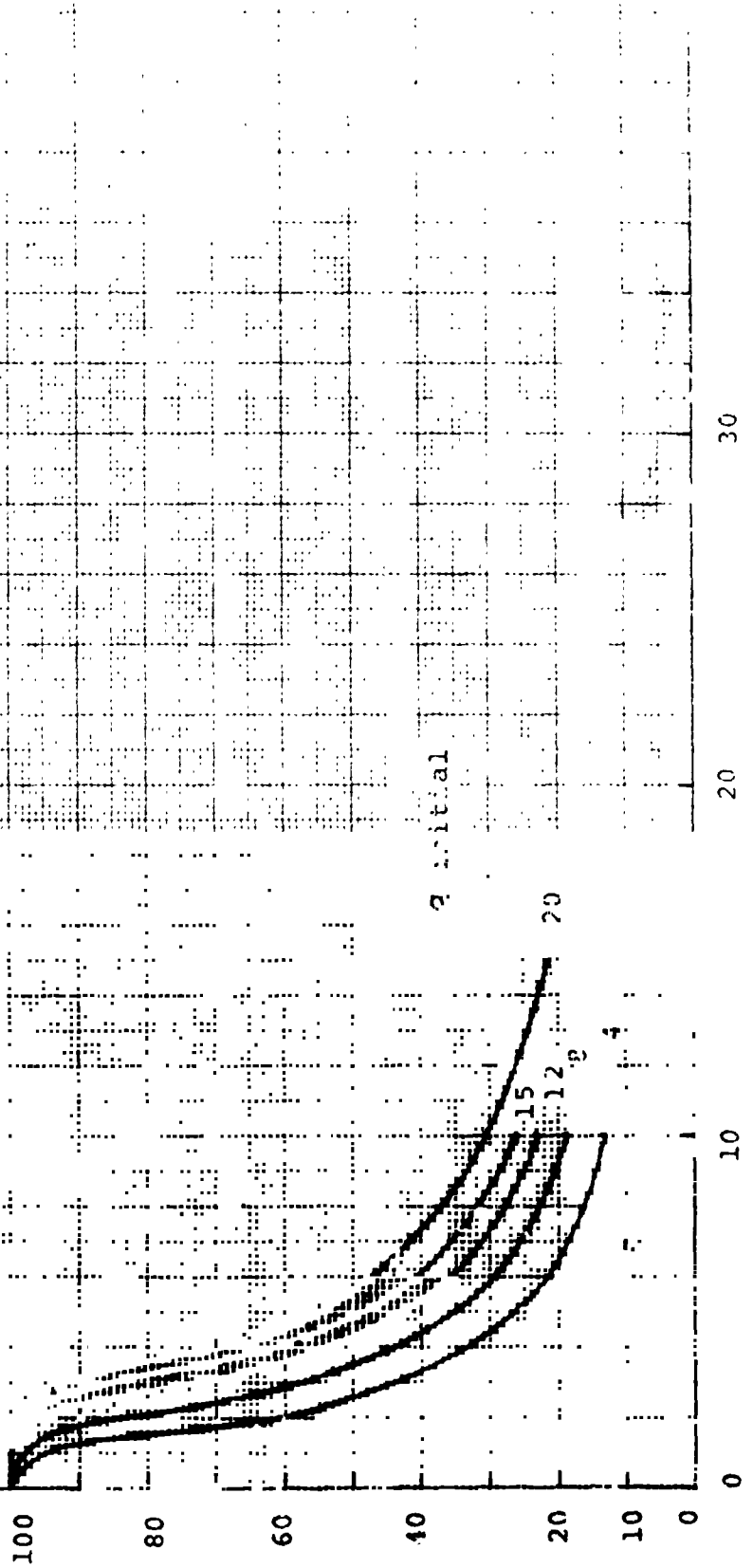

ALTITUDE INITIAL - FT x 10⁻³

ALTIMETER LOSS @ 95% Q_{TERM} AS A % OF ALTITUDE INITIAL

NOTE:
 1. PEAK G'S = 3.0
 2. $t_f = 24.0$ SEC
 3. $\gamma = -90^\circ$

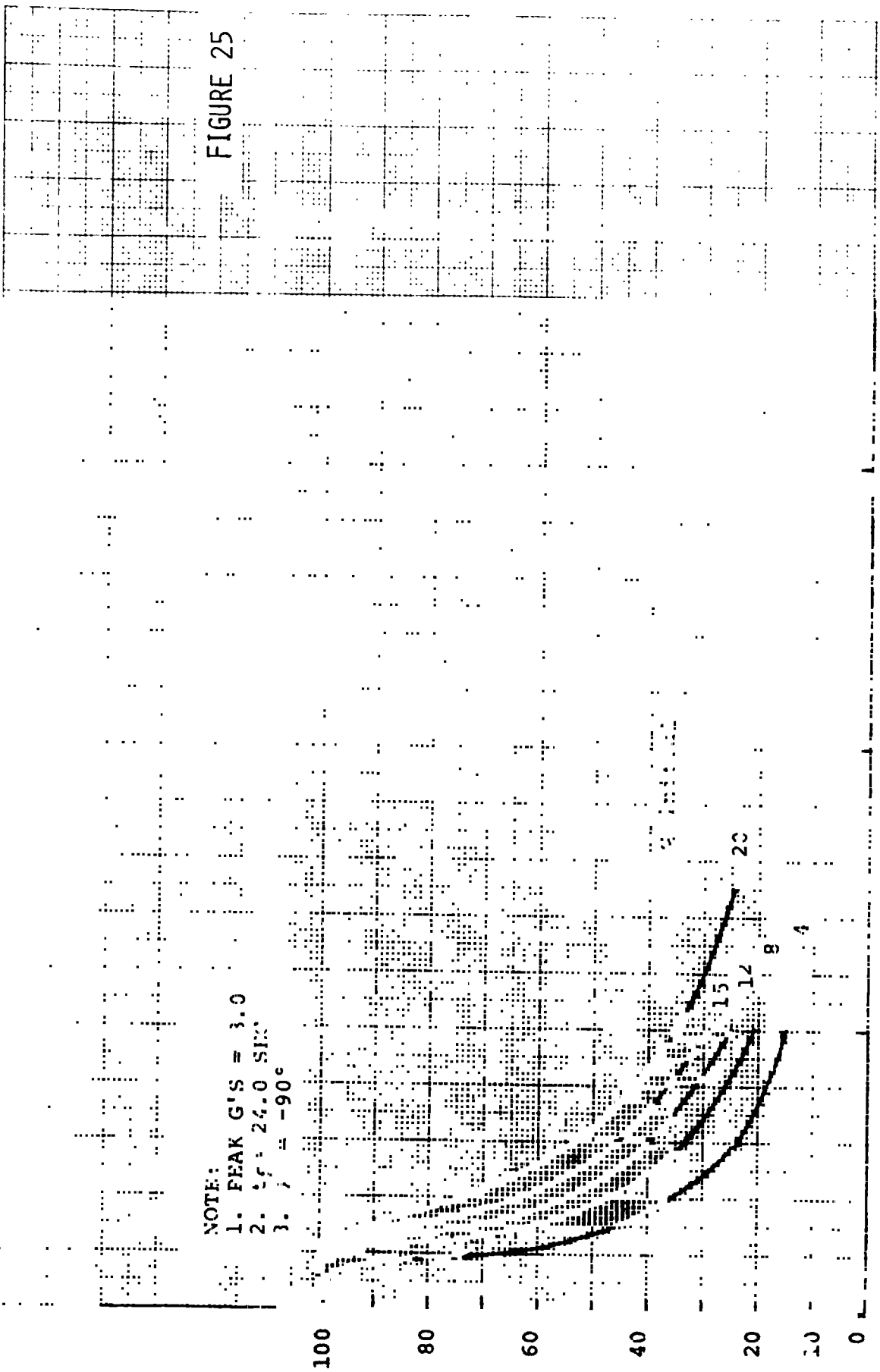

FIGURE 25

ALTITUDE INITIAL - FT x 10⁻³

ALTIUDE LOSS @ 95% TERM AS A % OF ALTIUDE INITIAL

- NOTE:
 1. PEAK G'S = 4.0
 2. $t_f = 5.0$ SEC
 3. $\omega = -70^\circ$

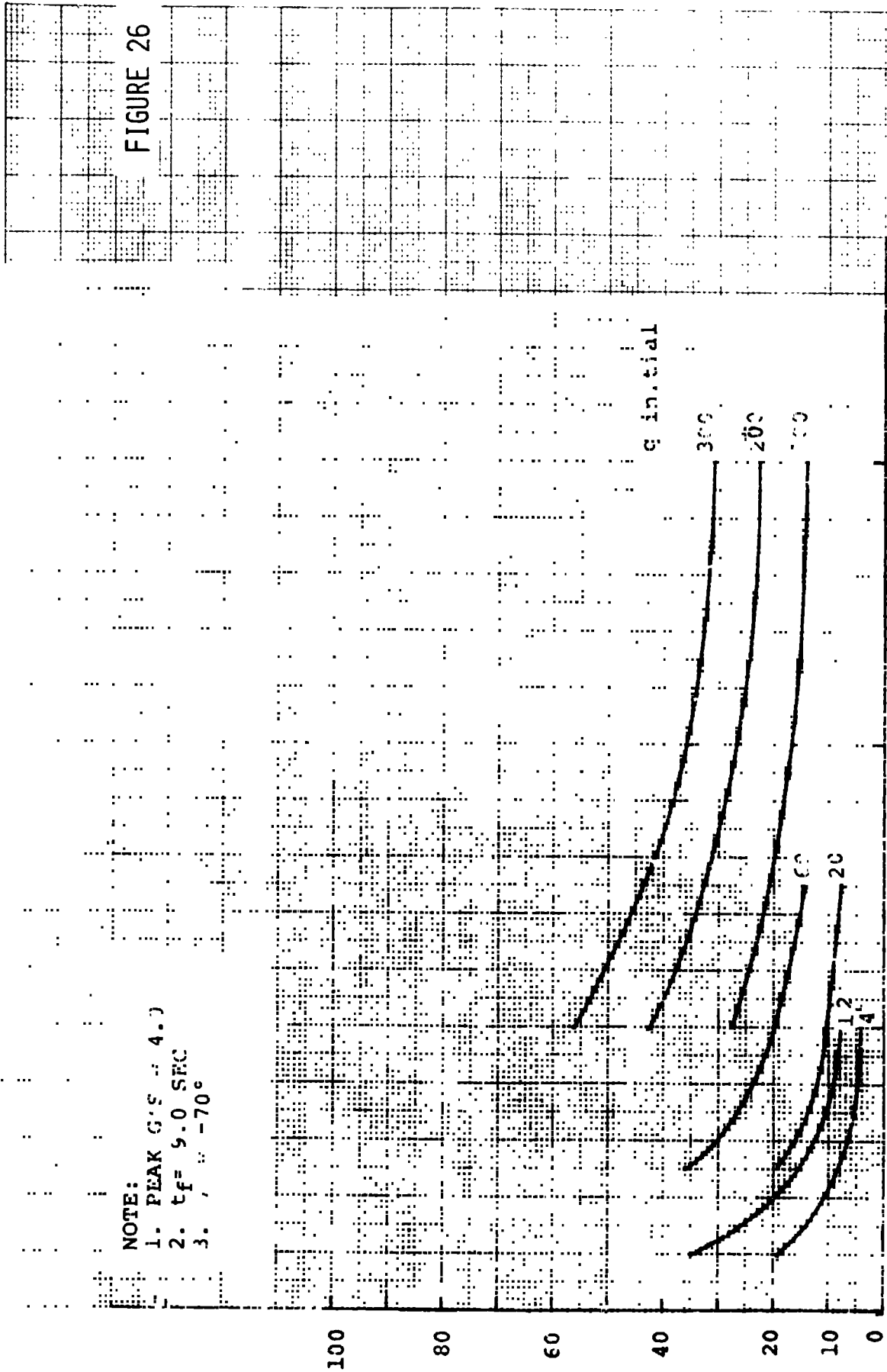

FIGURE 26

ALTIUDE LOSS @ 95% q_{TERM} AS A % OF ALTIUDE INITIAL

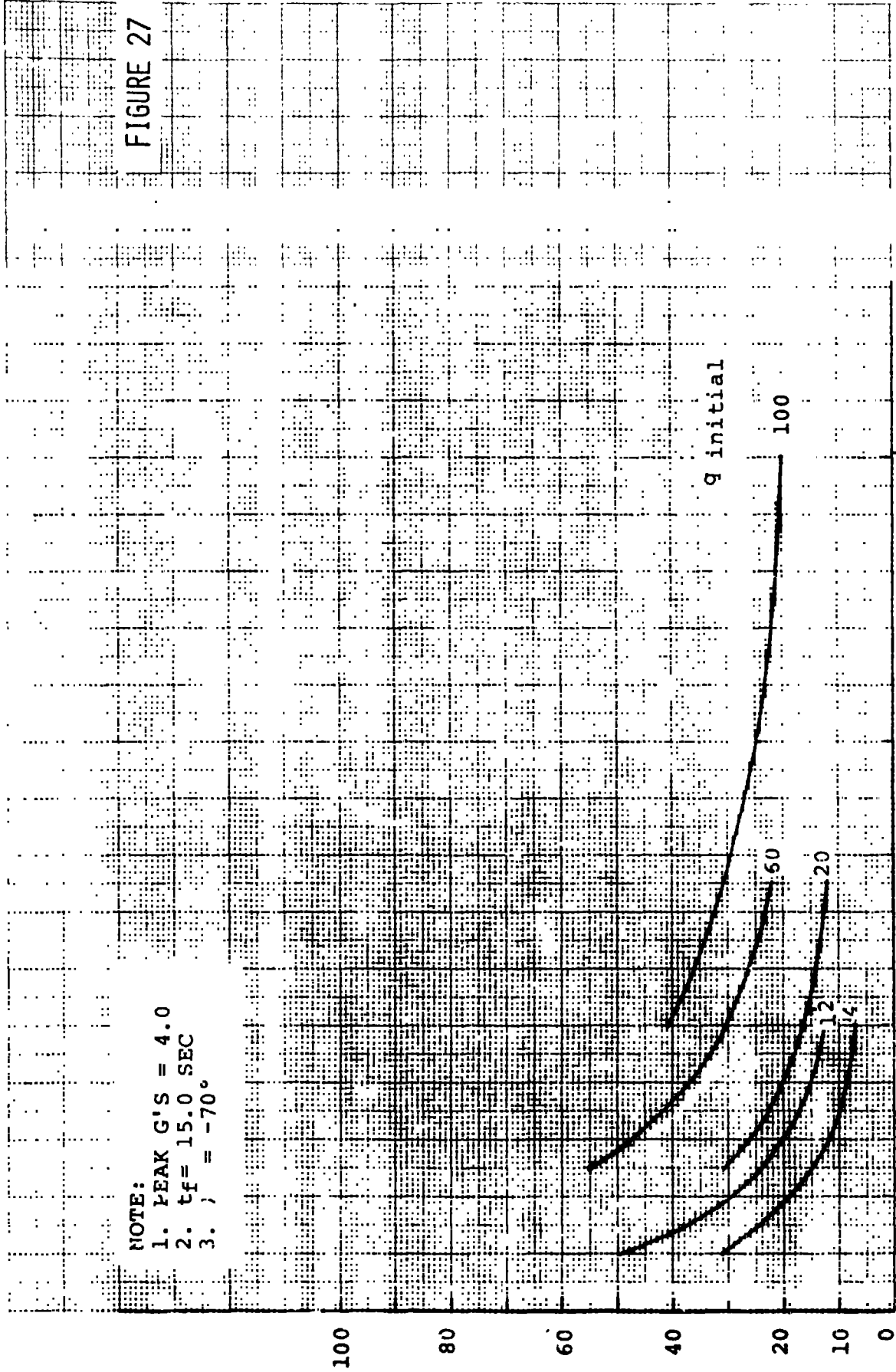
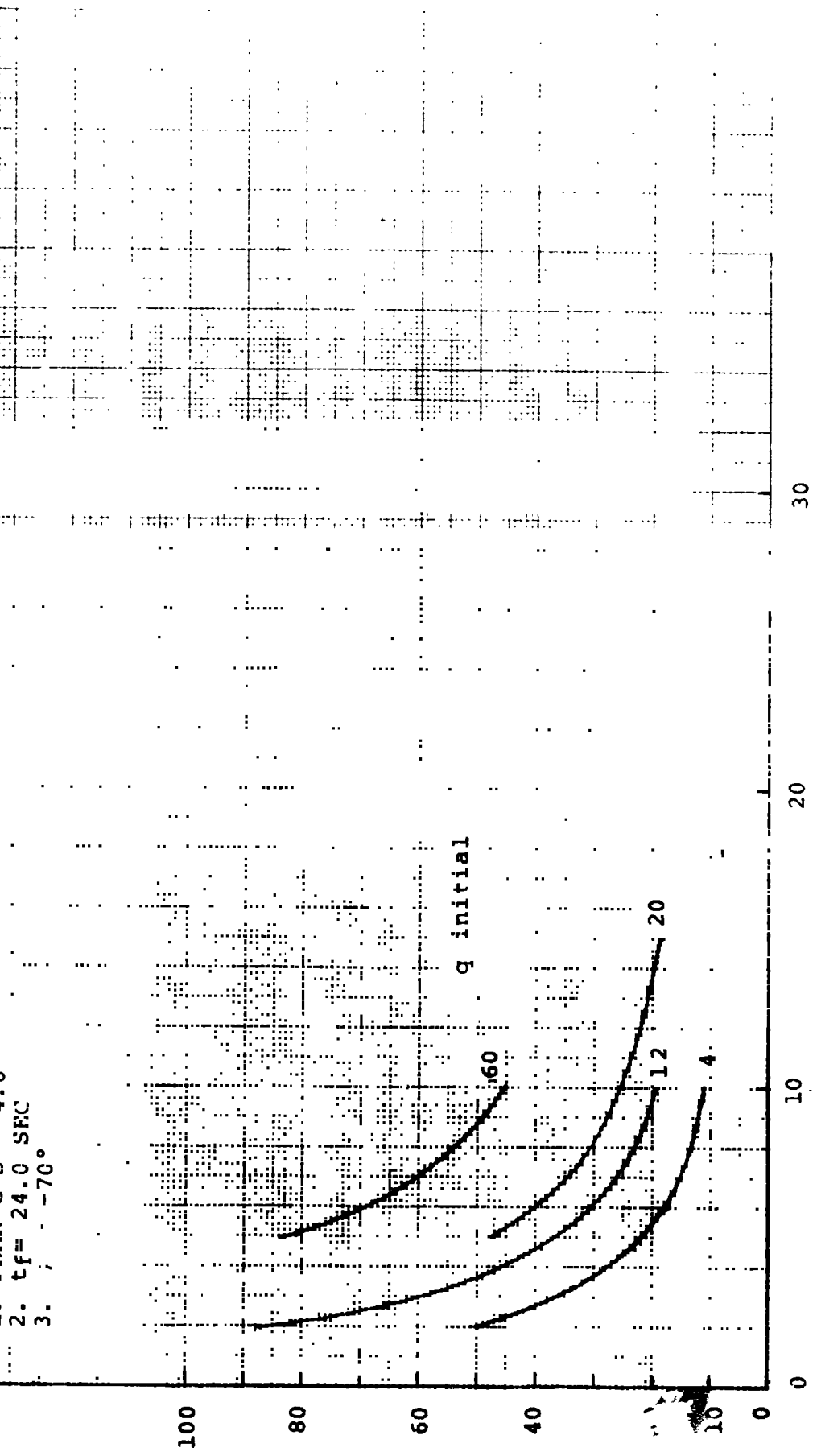

FIGURE 27

ALTITUDE LOSS @ 95% q_{TERM} AS A % OF ALTITUDE INITIAL

NOTE:
1. PEAK G'S = 4.0
2. $t_f = 24.0$ SEC
3. $\gamma = -70^\circ$

FIGURE 28



ALTITUDE INITIAL - FT x 10^{-3}

found to be approximately 50%, or disreef should occur at approximately 5,000 feet (.5 X 10,000 ft). (As a rule of thumb, it is desirable to try to limit the altitude loss to 50 percent of the initial altitude.)

At disreef of the first stage, the dynamic pressure should be

$$q_{DR_1} = \frac{q_D}{(G's)} \quad (18)$$

where

$$q_{DR_1} = \text{dynamic pressure at disreef of the first stage (1),} \\ \text{N/m}^2 \text{ (PSF)}$$

therefore

$$q_{DR_1} = \frac{203}{3} = 67.5 \text{ PSF}$$

at an altitude of 5000 feet, the corresponding velocity is 257 ft/sec and t_f/D_0 (PERFORMANCE) from Figure 16 is 0.088. The diameter of the second stage was calculated to be 80.4 feet but since the parachute was already partially inflated the amount which must be considered is the additional diameter which must be obtained, therefore

$$D_0 = 80.4 - 46.5 = 33.9 \text{ ft.}$$

and

$$t_f = .088 (33.9) = 2.92 \text{ seconds}$$

From Figure 18, at 5000 feet and $q = 67.5$ PSF the altitude loss ratio is approximately 33 percent. Disreef of the second stage will occur at approximately 5000 (1-.33) = 3300 feet.

The dynamic pressure at disreef of the second stage will be

$$q_{DR_2} = \frac{q_{DR_1}}{G's} \quad (19)$$

$$q_{DR_2} = \frac{67.5}{3} = 22.5$$

and the velocity corresponding at 3300 feet will be 144.5 ft/sec. The filling time ratio from Figure 16 is 0.135 and the filling time will be

$$t_f = 0.135 (139.6 - 80.4) = 8.25 \text{ sec.}$$

From Figure 20 at 3300 feet and $q = 22.5$ PSF, the altitude loss is approximately 40% or terminal conditions should be reached by an altitude of 3300 $(1 - .4) = 1980$ feet. (Since it is desirable to have system terminal prior to just touching the surface, for these low deceleration rates, 2000 feet has been selected as a preliminary altitude when this should occur.) Therefore, the criteria is nearly satisfied and will be assumed adequate at this time.

Presented in Table II is a summary of the data just generated.

REEFING TIMES

The reefing time is the amount of time when a particular stage reefed drag area is permitted to be effective. This time is established to permit the system to decelerate to the condition compatible with disreef and inflation to the next stage. In order to provide the user with a basic estimate for these values, the results of the point mass trajectory runs previously discussed were plotted as reefing time versus initial altitude at various deployment or disreef dynamic pressures. Figures 29 thru 37 present this data for parachute inflation times of 1 to 24 seconds for initial deceleration of 3 G's, and a flight path angle of -90 degrees. In addition, Figures 38, 39 and 40 present 4G decelerations at -70 degrees and inflation times of 9, 15 and 24 seconds respectively. The reefing times plotted are those values taken from the computer run when the system has decelerated to 95 percent of q terminal for that stage. The 95 percent value is defined as:

$$q_{95} = q_D - .95 (q_D - q_T) \tag{20}$$

From Table II for the initial conditions summarized the reefing times can be obtained from Figure which reflects the nearest value of inflation time. The respective values are summarized in Table III.

TABLE III
SUMMARY OF REEFING TIMES

Stage	Figure Number	Reefing Time (Sec)
1st	30	15
2nd	30	9

Reefing times are only required for the two stages of reefing. After the parachute reaches full open the system remains at that drag area until surface impact.

C. Definition of Drogue Parachute Decelerator

1. General

The drogue parachute device is required to decelerate and/or stabilize the

TABLE II - SUMMARY OF EXAMPLE DEPLOYMENT CONDITIONS
AND INFLATION TIMES

Stage	Initial Altitude (ft)	Initial q (PSF)	Initial Velocity (ft/sec)	Diameter Initial (ft)	Final (ft)	Filling Time t_f (sec)
1st	10,000	203	481	0	46.5	2.07
2nd	5,000	67.5	257	46.5	80.4	2.92
Full Open	3,300	22.5	144.5	80.4	139.6	8.25

FIGURE 29

- NOTE:
1. G'S = 3.0
 2. 95% q_{TERM}
 3. $t_g = 1$ SEC
 4. $\gamma = -90^\circ$

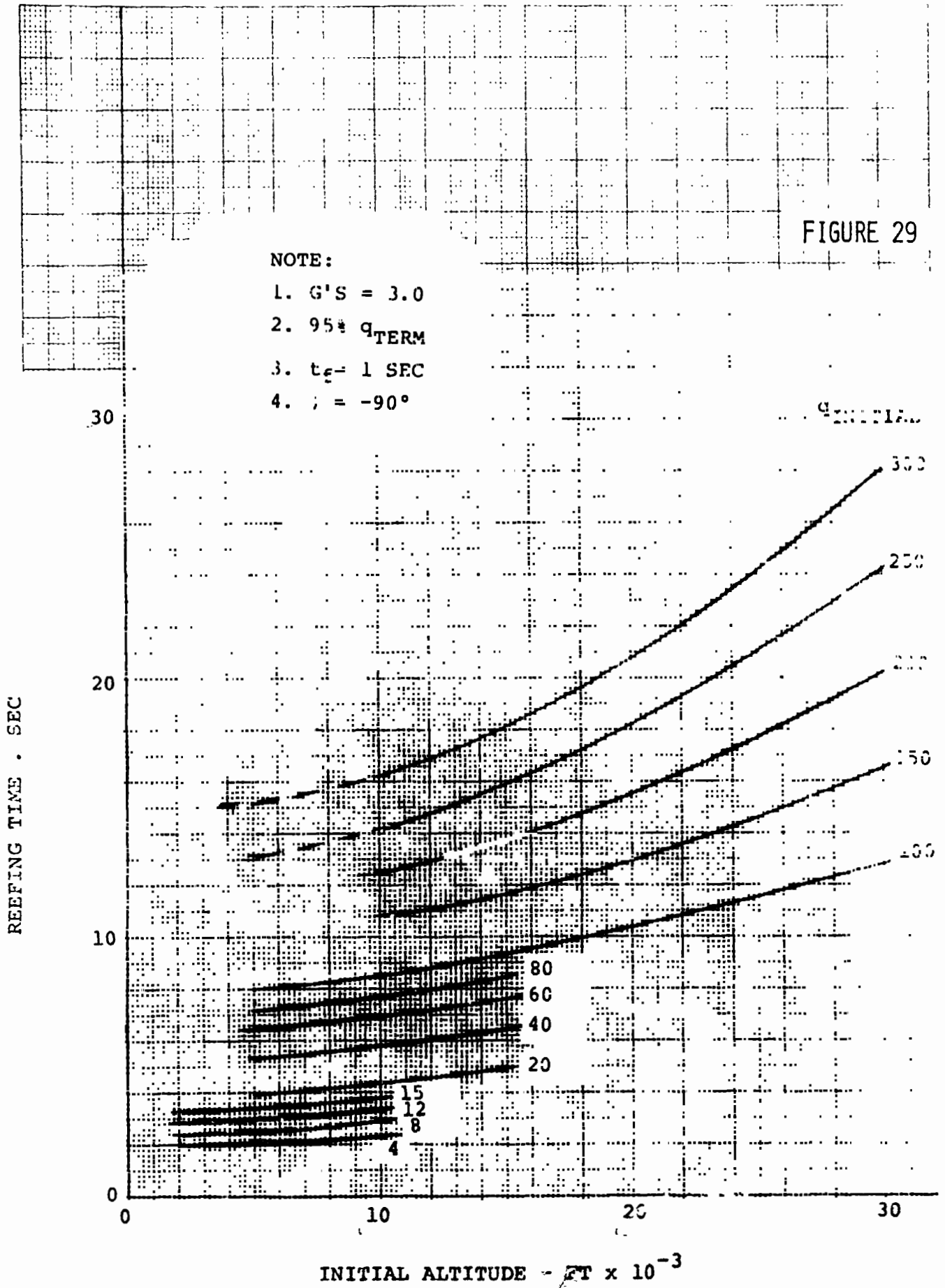

FIGURE 30

- NOTE:
- 1. G'S = 3.0
 - 2. 95% σ_{TERM}
 - 3. $t_f = 3$ SEC
 - 4. $\gamma = -90^\circ$

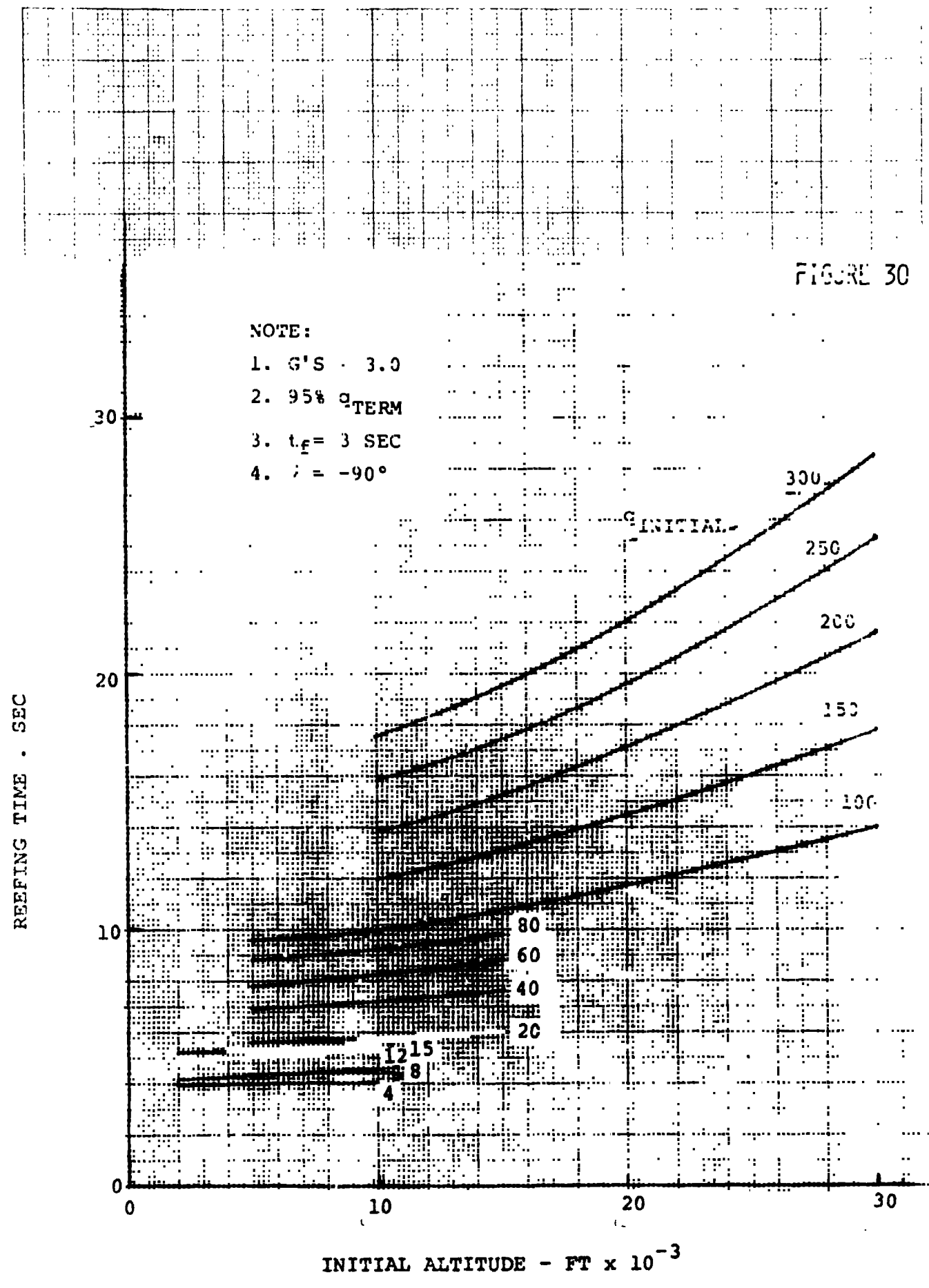

FIGURE 31

NOTE:

- 1. G'S = 3.0
- 2. 95% q_{term}
- 3. $t_f = 6$ SEC
- 4. $\gamma = -90^\circ$

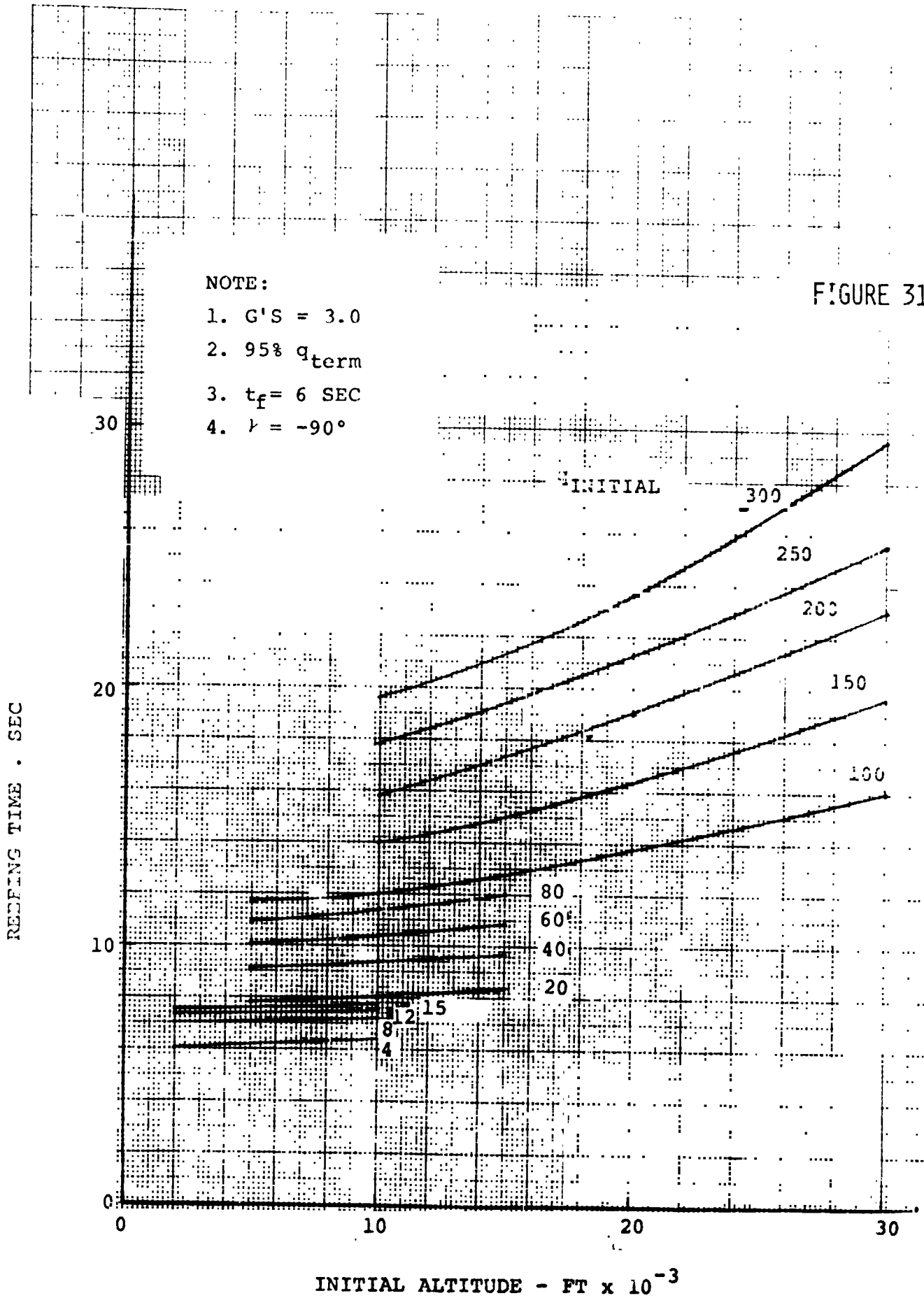

FIGURE 32

- NOTE:
1. $G'S = 3.0$
 2. 95% q_{term}
 3. $t_f = 9$ SEC
 4. $\gamma = -90^\circ$

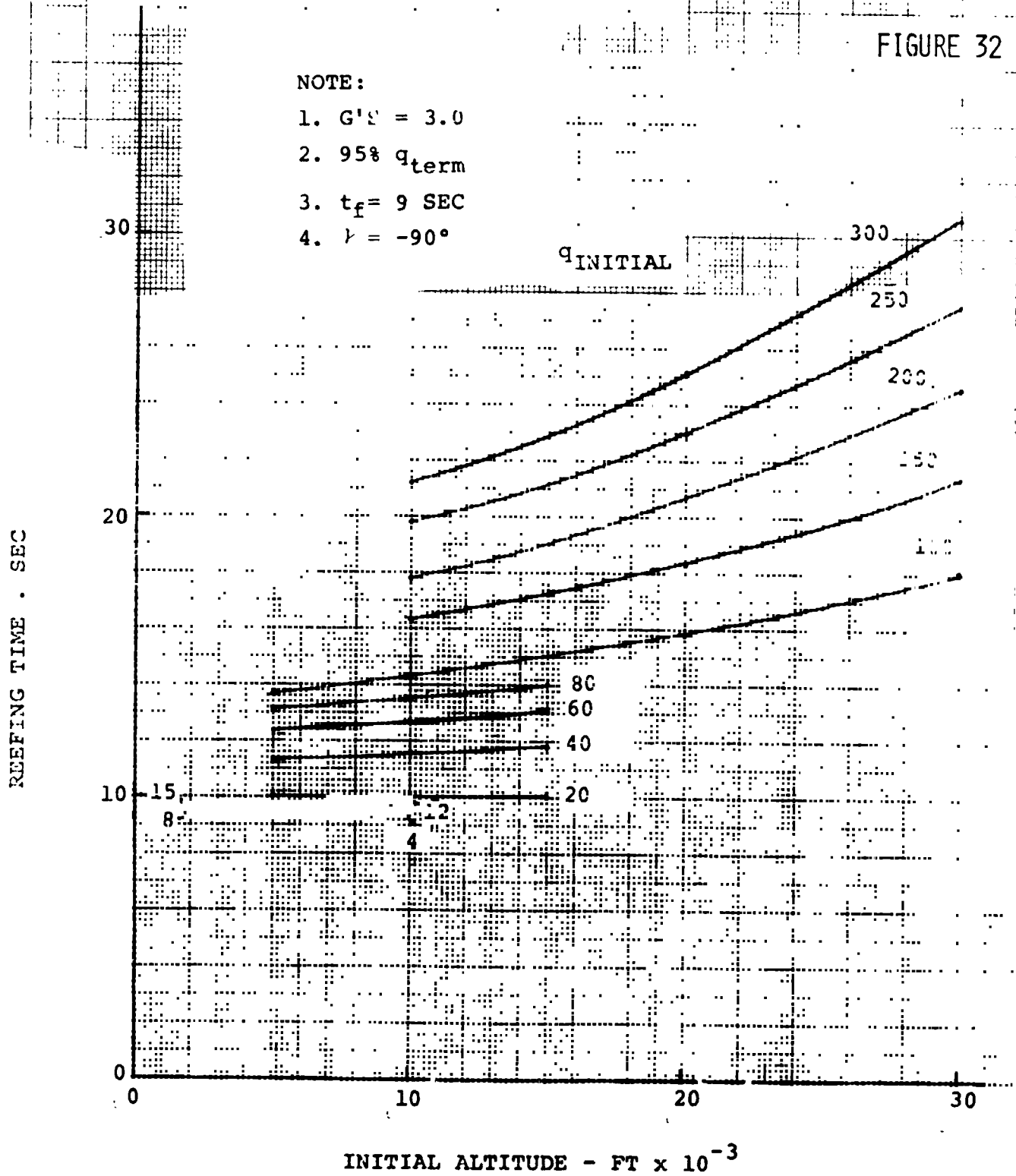

FIGURE 33

NOTE:

- 1. G'S = 3.0
- 2. 95% q_{TERM}
- 3. $t_c = 12.0$ SEC
- 4. $\gamma = -90^\circ$

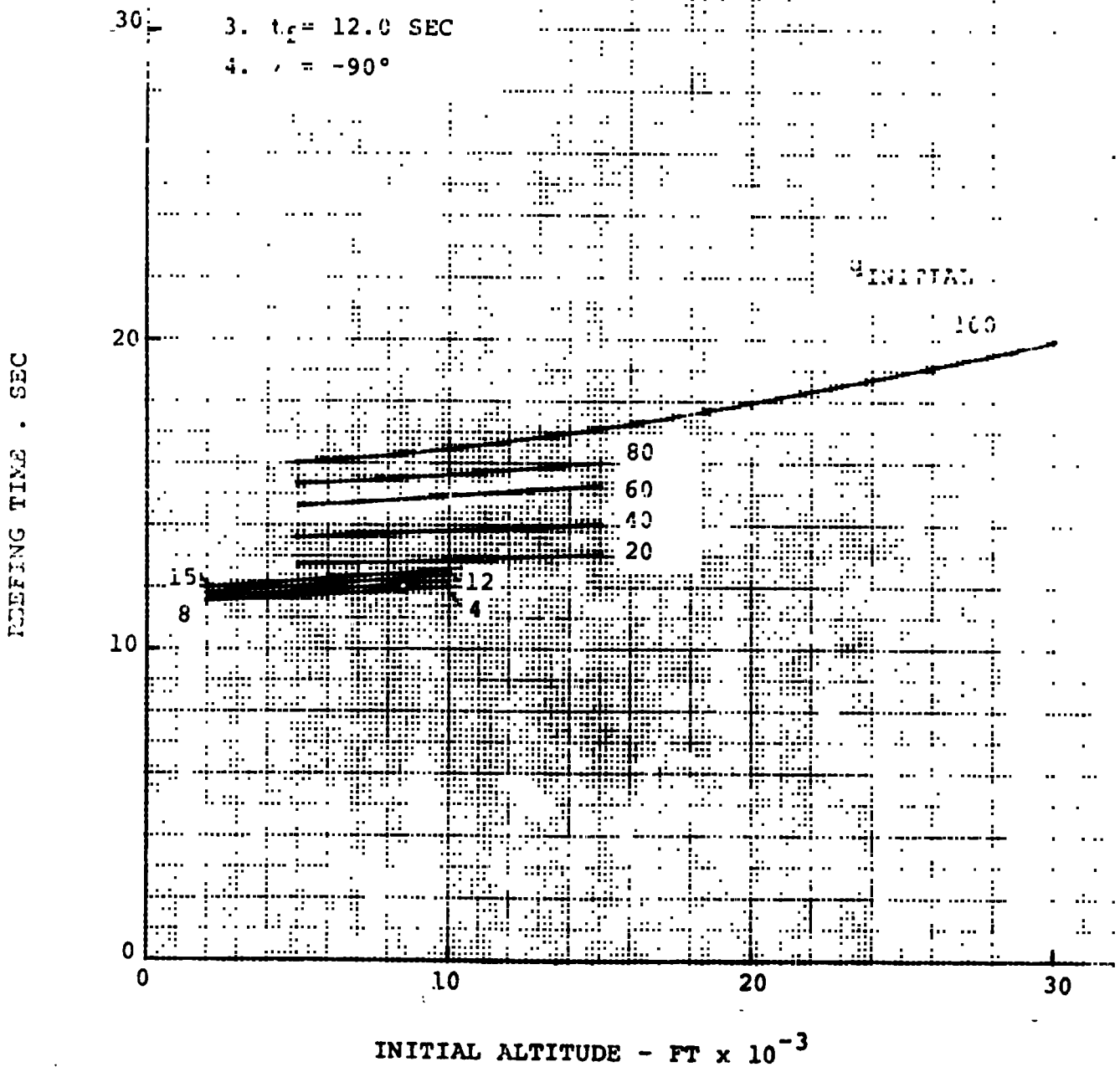
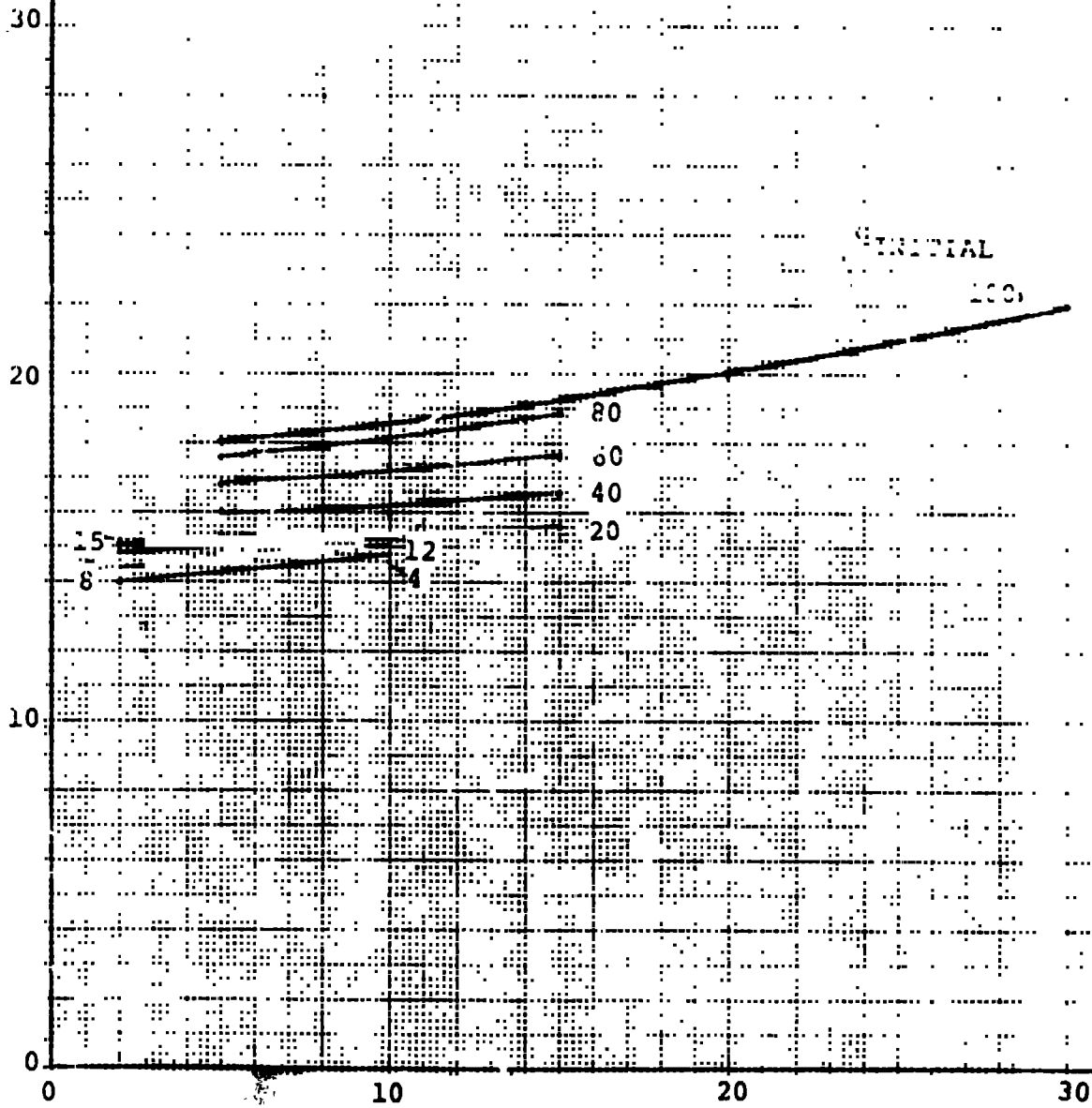

FIGURE 34

NOTE:

- 1. G'S = 3.0
- 2. 95% q_{TERM}
- 3. $\tau_f = 15$ SEC
- 4. $\gamma = -90^\circ$

REEPING TIME - SEC



INITIAL ALTITUDE - FT x 10⁻³

FIGURE 35

NOTE:

- 1. G'S = 3.0
- 2. 95% q_{TERM}
- 3. $t_f = 18$ SEC
- 4. $\delta = -90^\circ$

REEPING TIME - SEC

30

20

10

0

15
8

12
4

10

10

20

30

INITIAL ALTITUDE - FT $\times 10^{-3}$

FIGURE 36

NOTE:

- 1. G'S = 3.0
- 2. 95% q_{TERM}
- 3. $t_f = 21$ SEC
- 4. $\lambda = -90^\circ$

REEFING TIME - SEC

30

20

10

0

$g_{INITIAL}$

20

15

8

12

4

10

20

30

INITIAL ALTITUDE - FT x 10^{-3}

F

FIGURE 37

NOTE:

- 1. G'S = 3.0
- 2. 95% q_{TERM}
- 3. $t_f = 24$ SEC
- 4. $\delta = -90^\circ$

REEFING TIME . SEC

30

20

10

0

$q_{INITIAL}$

20

12

4

15

8

10

20

30

INITIAL ALTITUDE - FT x 10^{-3}

FIGURE 38

- NOTE:
- 1. G'S = 4.0
 - 2. 95% q_{TERM}
 - 3. $t_f = 9$ SEC
 - 4. $\gamma = -70^\circ$

REEPING TIME - SEC

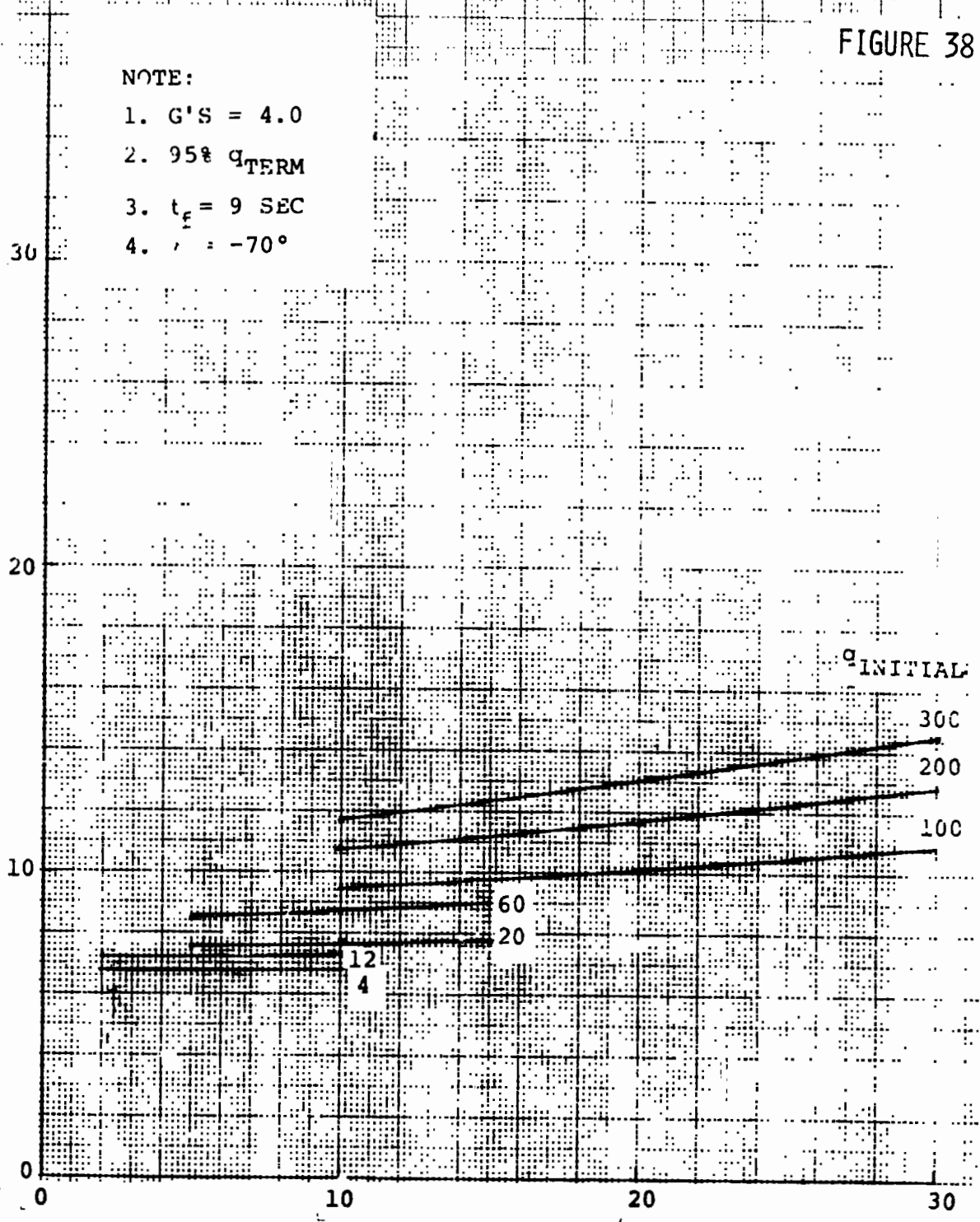

INITIAL ALTITUDE - FT x 10⁻³

FIGURE 39

NOTE:

- 1. G'S - 4.0
- 2. 95% G TERM
- 3. $t_f = 15$ SEC
- 4. $\gamma = -70^\circ$

REEFING TIME - SEC

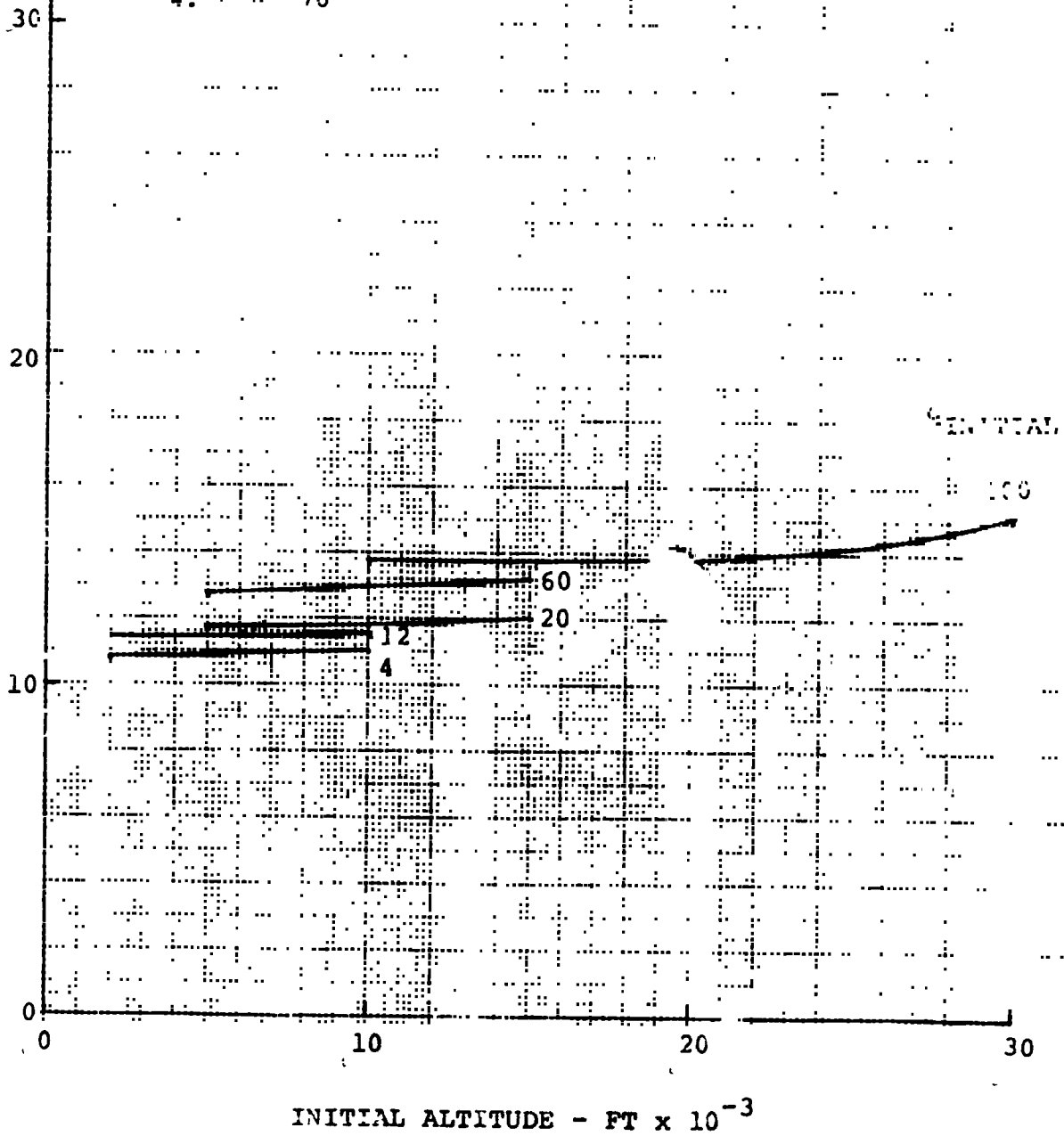

INITIAL ALTITUDE - FT x 10⁻³

FIGURE 40

NOTE:

- 1. G'S 4.0
- 2. 95% q_{TERM}
- 3. $t_f = 24$ SEC
- 4. $\gamma = -70^\circ$

KEEPING TIME - SEC

30

20

10

0

10

20

30

INITIAL ALTITUDE - FT $\times 10^{-3}$

60

20'

12

4

SRB to conditions compatible with the main parachute deployment environment. The methodology for defining the drogue parachute, which will satisfy this will be discussed in the following paragraphs. This will include drogue sizing, deployment conditions, inflation times and drogue weight.

2. Drogue Parachute Sizing

Definition of the size of the drogue parachute is dependent on:

1. Dynamic pressure at the time of main parachute deployment
2. Altitude at main parachute deployment
3. Altitude at the time of drogue deployment
4. Dynamic pressure (or velocity at the time of drogue deployment)
5. The maximum deceleration level compatible with SRB structure.

A first pass approximation to drogue size can be obtained by assuming that the system while descending on the drogue has sufficient time to decelerate to the desired terminal ballistic state and then calculate the drogue drag area compatible with the main parachute deployment q . The minimum drogue $C_D A$ would be

$$C_{DA \min} = \frac{W_T}{(q_D)_{\text{mains}}} \quad (21)$$

where

W_T = total descent weight on drogue, equals W_{SRB} = weight of main subsystem + weight of the drogue. N (lbs)

q_D = maximum deployment dynamic pressure for the mains, N/r^2 (PSF)

For performance purposes, it has been found that this minimum value should be increased by a factor of 1/.90 to insure that the desired q_D is obtained. Presented in Figure 41 is the drogue drag area versus main parachute deployment q for the weight range from 150,000 to 300,000 pounds. The diameter of the drogue parachute can then be obtained from Figure 42 when the drag area is known and when $C_{D0} = .55$. This value is reasonable for the subsonic condition at the time of main parachute deployment.

3. Drogue Deployment Conditions

The deployment conditions for the drogue must provide sufficient altitude for the drogue deceleration to be effective, while at the same time reducing the deceleration G's to a minimum value.

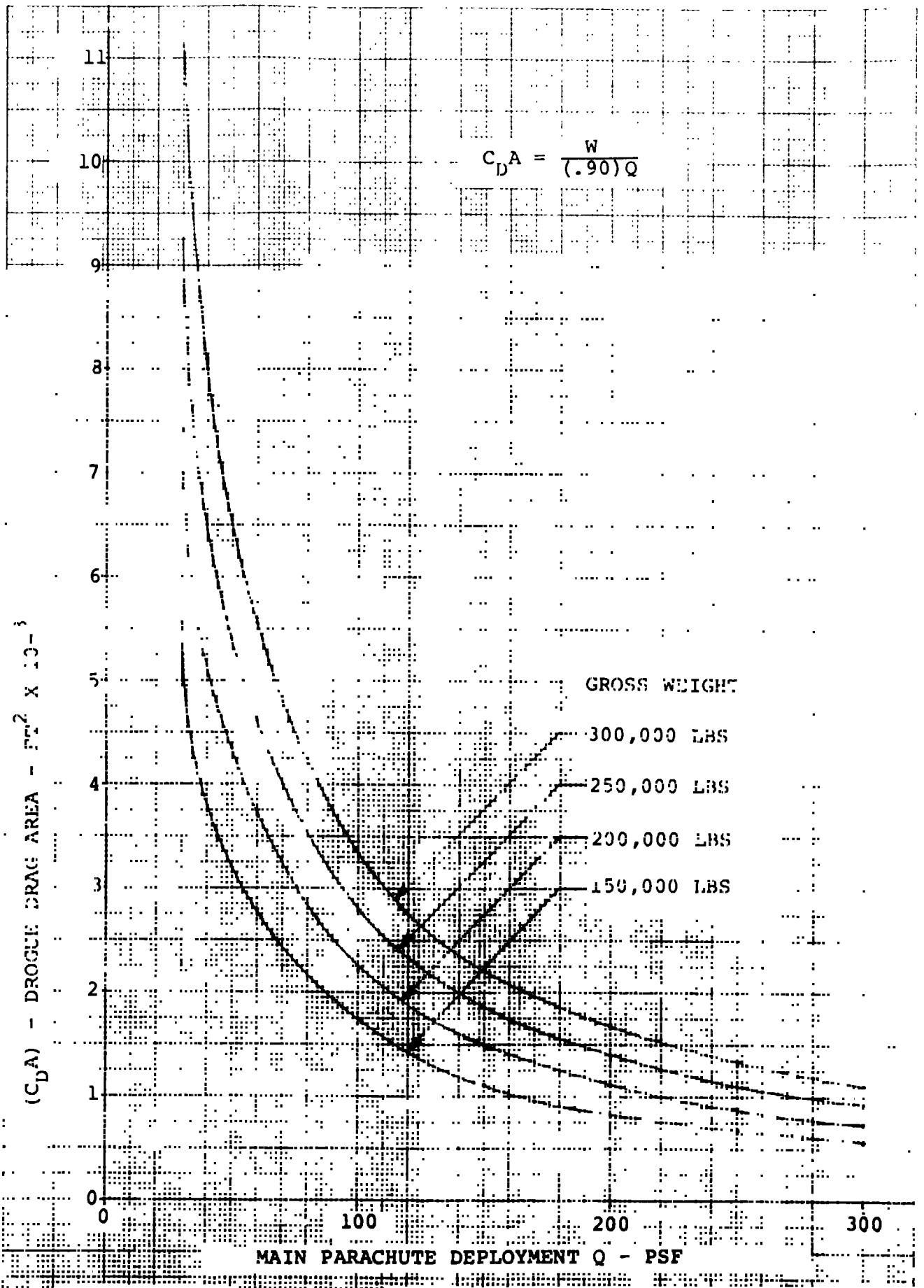

FIGURE 41 - DROGUE DRAG AREA VERSUS MAIN PARACHUTE DEPLOYMENT Q

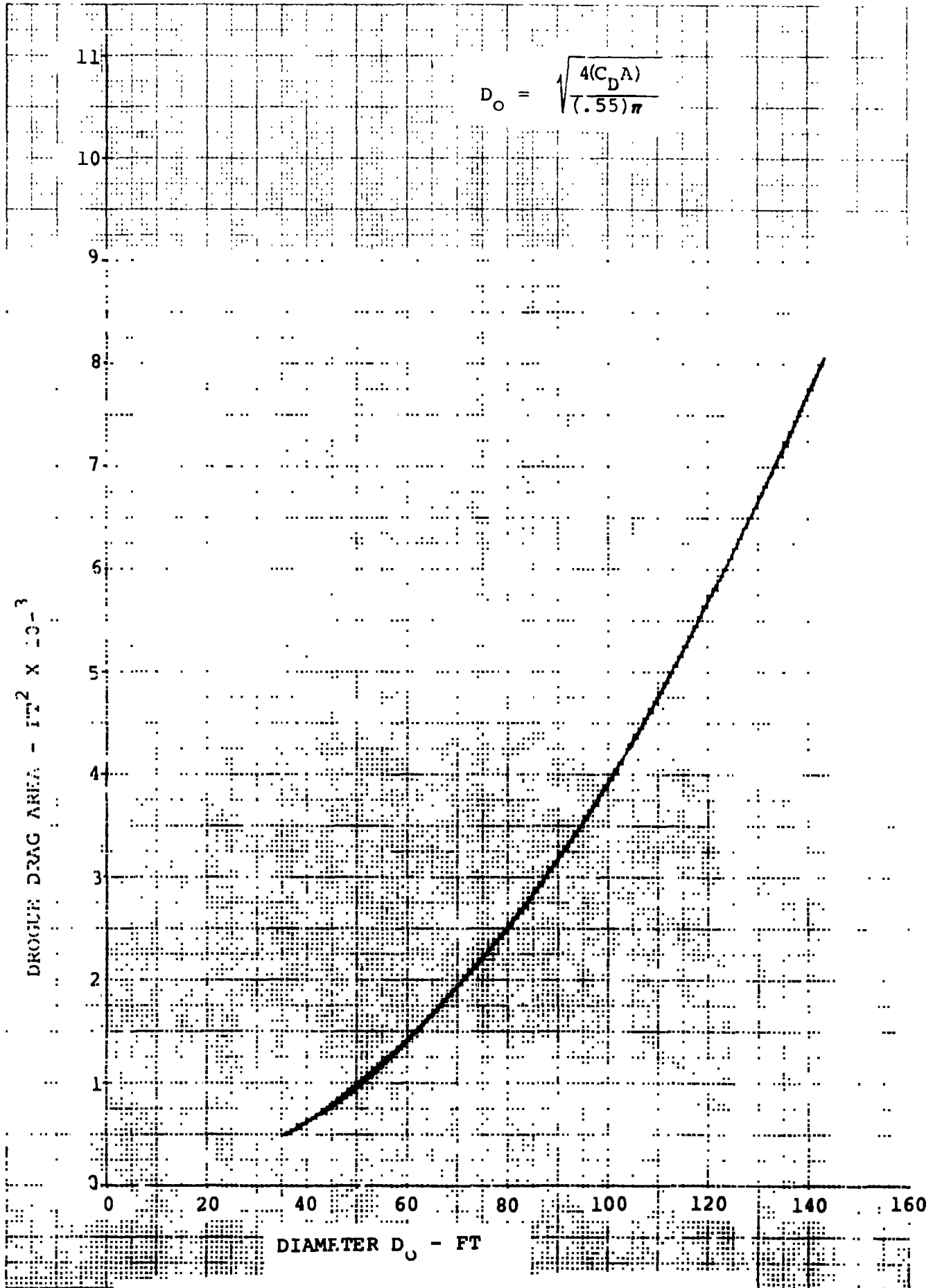

FIGURE 42 - DROGUE DRAG AREA VERSUS PARACHUTE DIAMETER D_0

From the trajectory of the SRB alone, conditions along its flight must be taken and individually considered to establish an optimum drogue system. A typical example of the SRB alone trajectory is shown in Figure 43. In addition, constant Mach numbers of 1.4, 1.0 and 0.6 are also shown for the altitude range from 60,000 feet to sea level. The basic SRB alone conditions are shown to give the user of this manual a basic starting point. As more refined data becomes available, it can be plotted also, and Figure 43 upgraded.

To assist in selection of the drogue deployment conditions, and also insure proper drogue sizing, a second series of point mass trajectories were conducted to assist in this evaluation. The results of these runs are summarized in Figures 44 thru 88, and are presented in a form of altitude versus dynamic pressure for various terminal W/C_{DA} values (on the drogue). The affects of Mach number, inflation time and flight path angle are then presented on the various plots. The Mach numbers considered are 1.4, 1.0 and 0.6; filling times of 1, 2 and 4 seconds; flight path angles of -90, -70 and -50 degrees; at initial altitudes of 50,000, 40,000 and 30,000 feet. These figures basically show the q curve resulting for a system descending with a terminal W/C_{DA} shown, and starting at the particular initial altitude, velocity, and flight path angle.

The use of these curves will be discussed in the following Section II-C. 5.

4. Calculation of Drogue Parachute System Weight

The calculation for the weight of the drogue parachute tether, and bridle is obtained similar to that of the mains as reflected by Equations 8 and 10. For the drogue though the values for some of the terms and factors change. The values for the drogue are:

W_p = weight of drogue parachute, N(lbs)

W = total weight = suspended weight + parachute weight, N(lbs)

G 's = deceleration load factor

D_o = nominal parachute diameter, m (ft)

F_{LP} = 0.0

(D. F.) = overall design factor for suspension lines including a margin of safety of 2.0 = 2.5

(D. F.)_c = overall design factor for canopy including a margin of safety of 2.0 = 2.5

(C. F.) = construction factor for suspension lines = 1.05

(C. F.)_c = construction factors for canopy seams, overlaps, thread, and reinforcing = 1.3

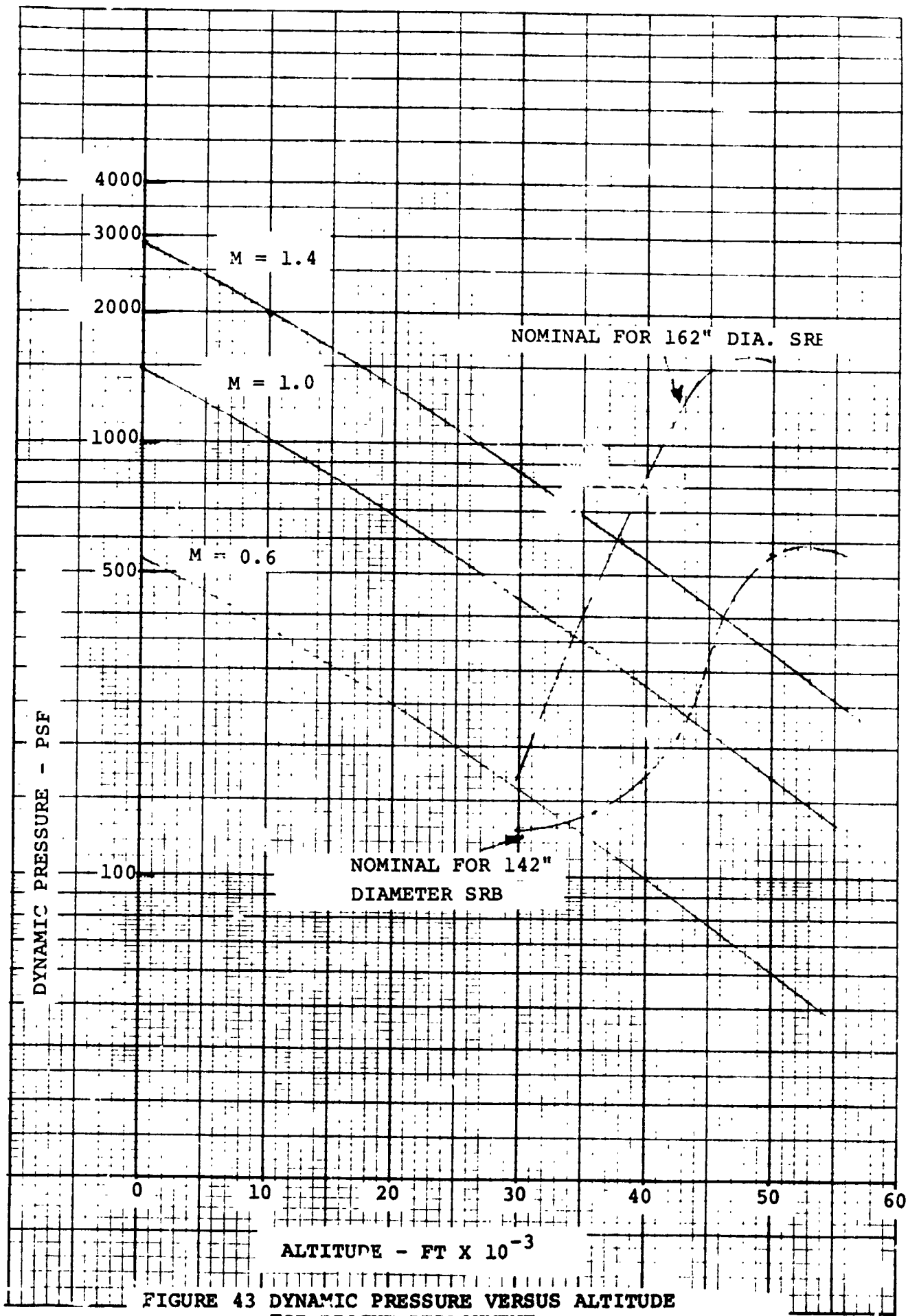

FIGURE 43 DYNAMIC PRESSURE VERSUS ALTITUDE FOR DROGUE DEPLOYMENT

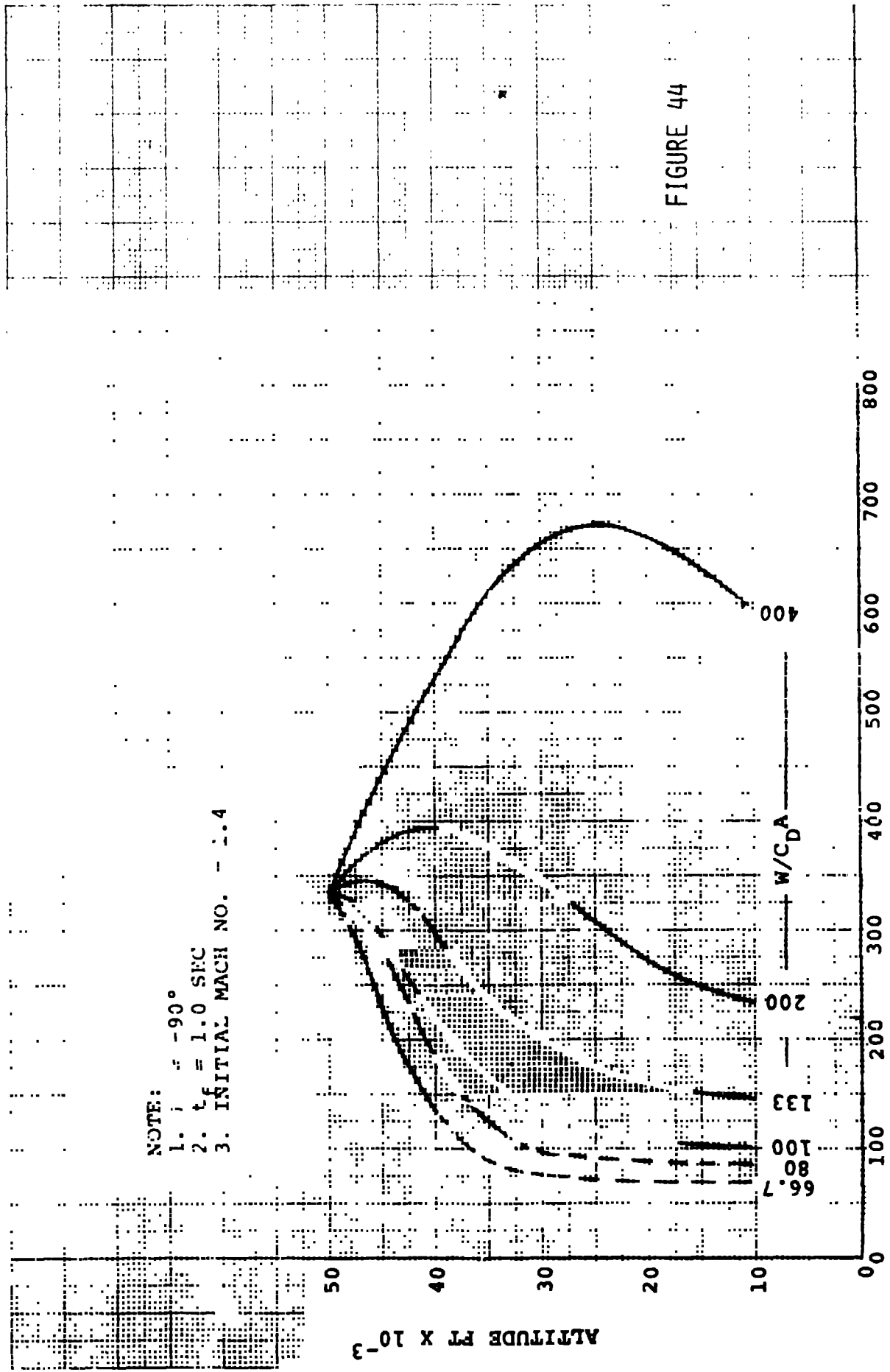
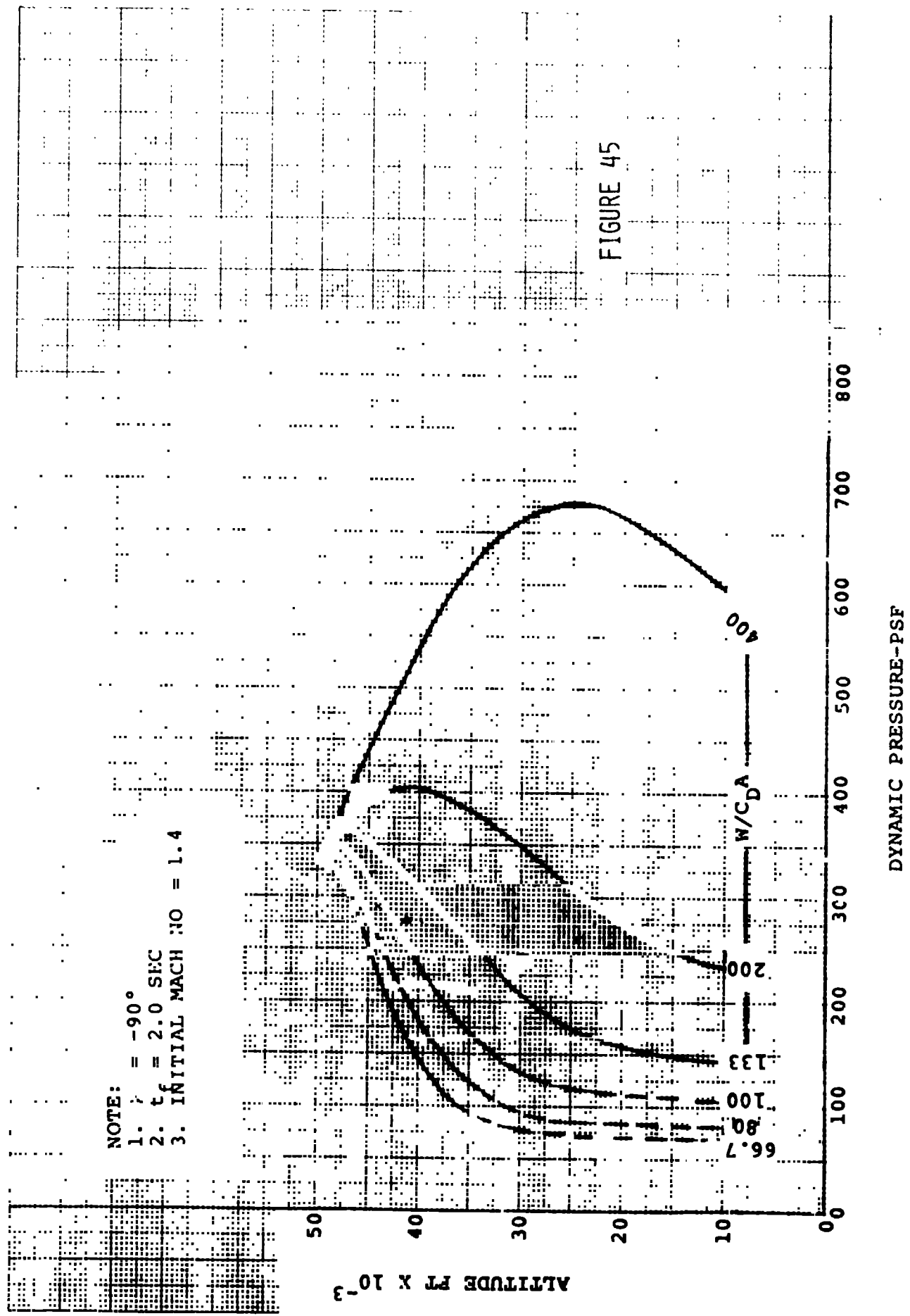

FIGURE 44



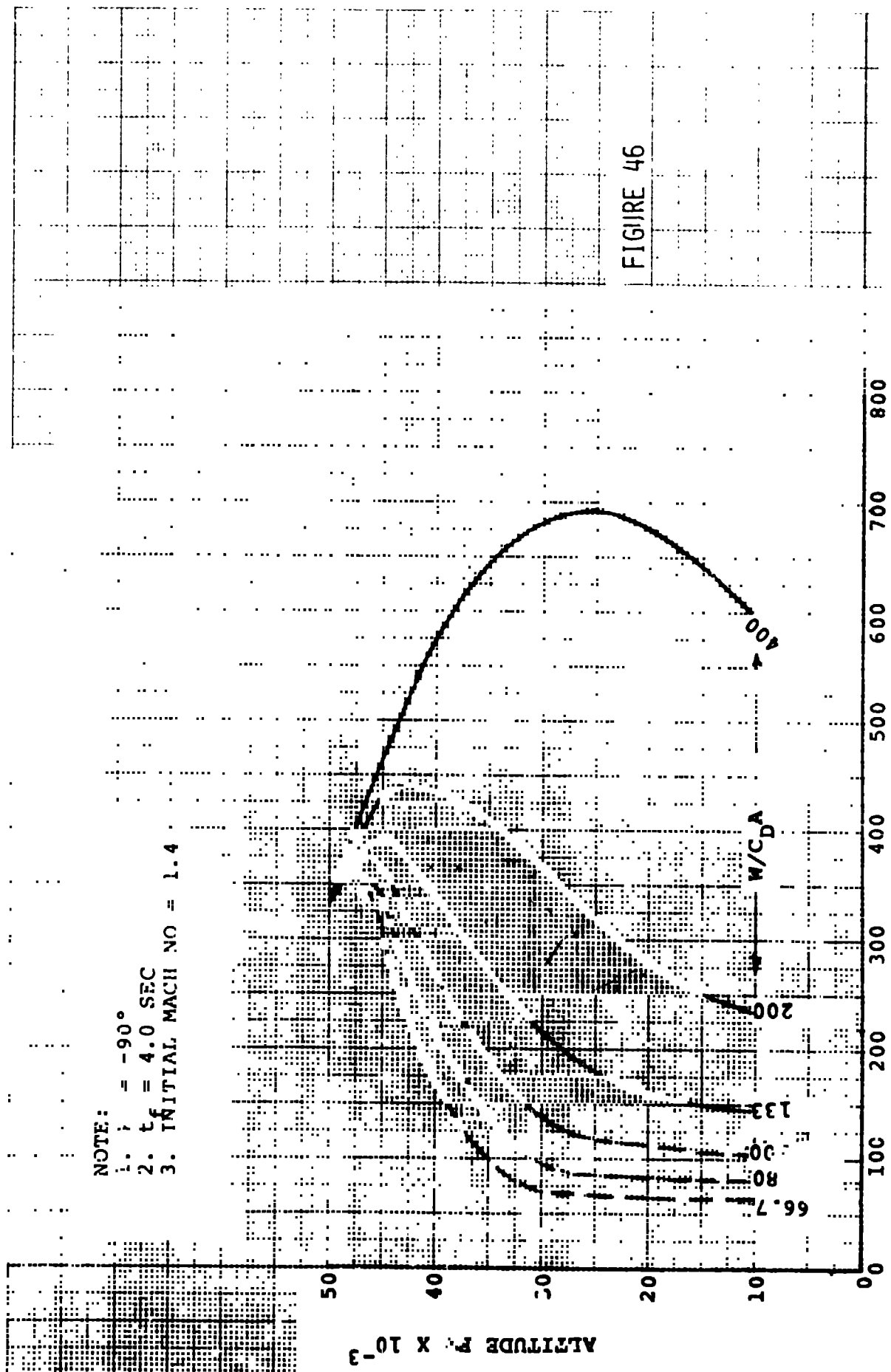
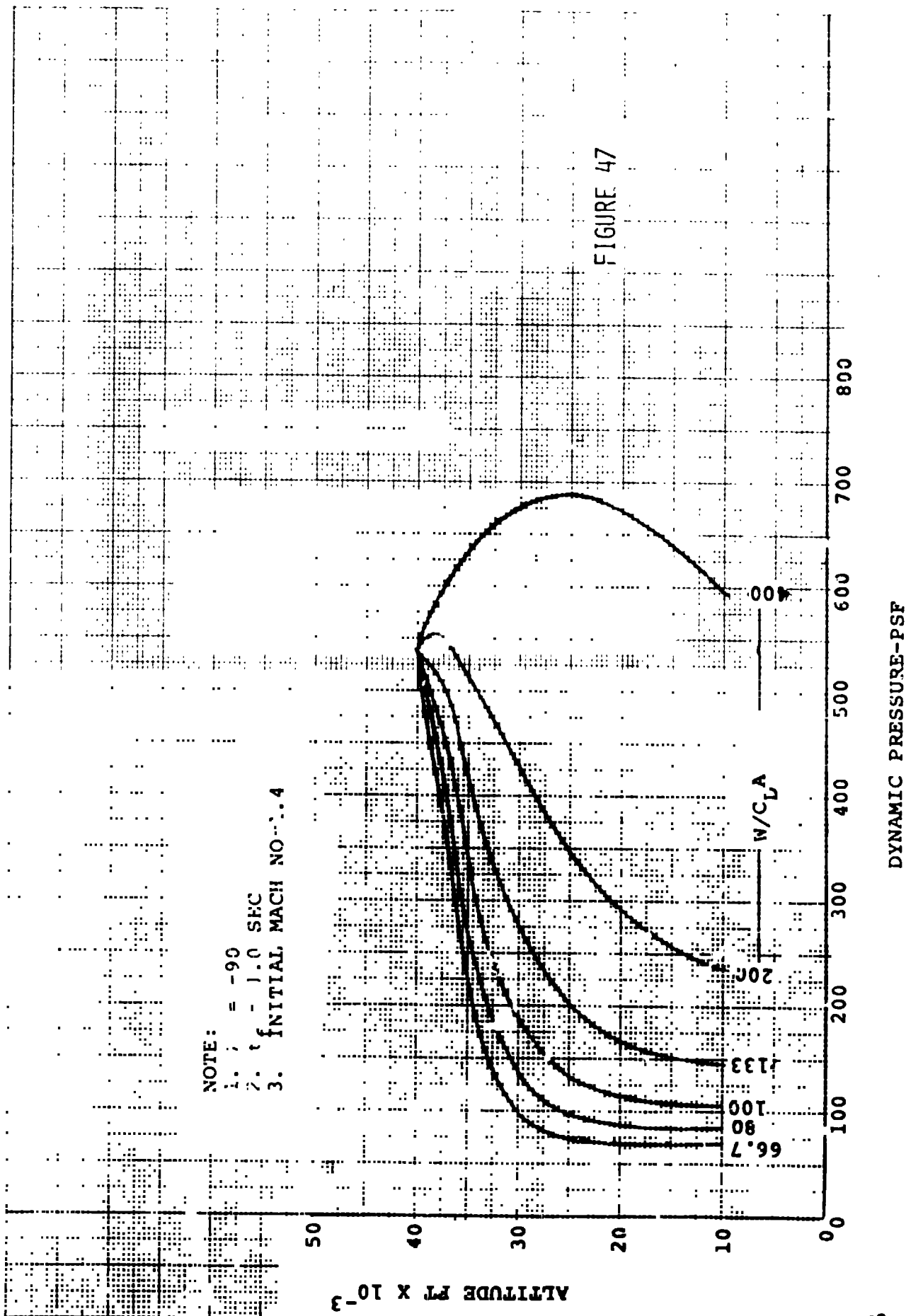

FIGURE 46



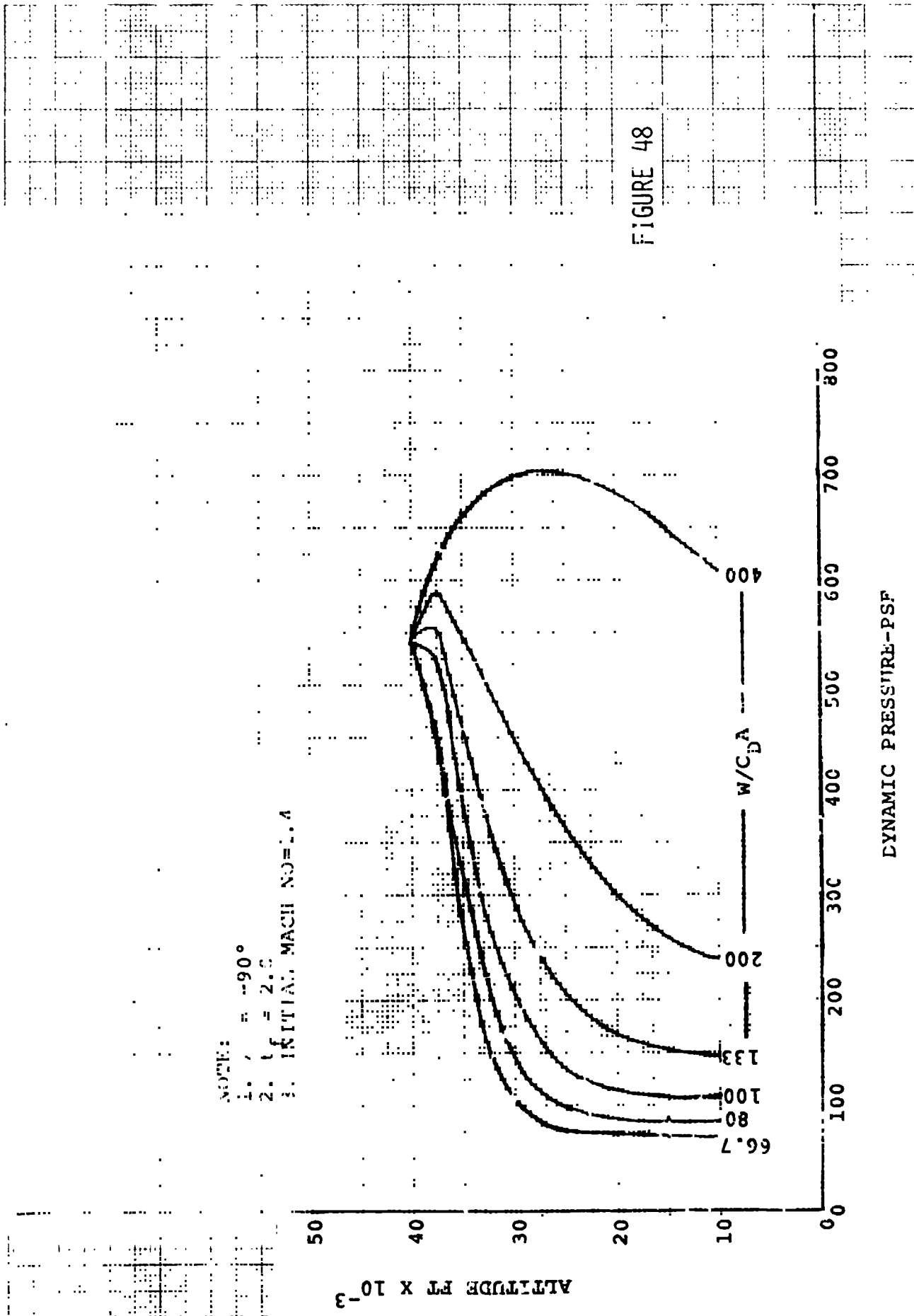

FIGURE 48

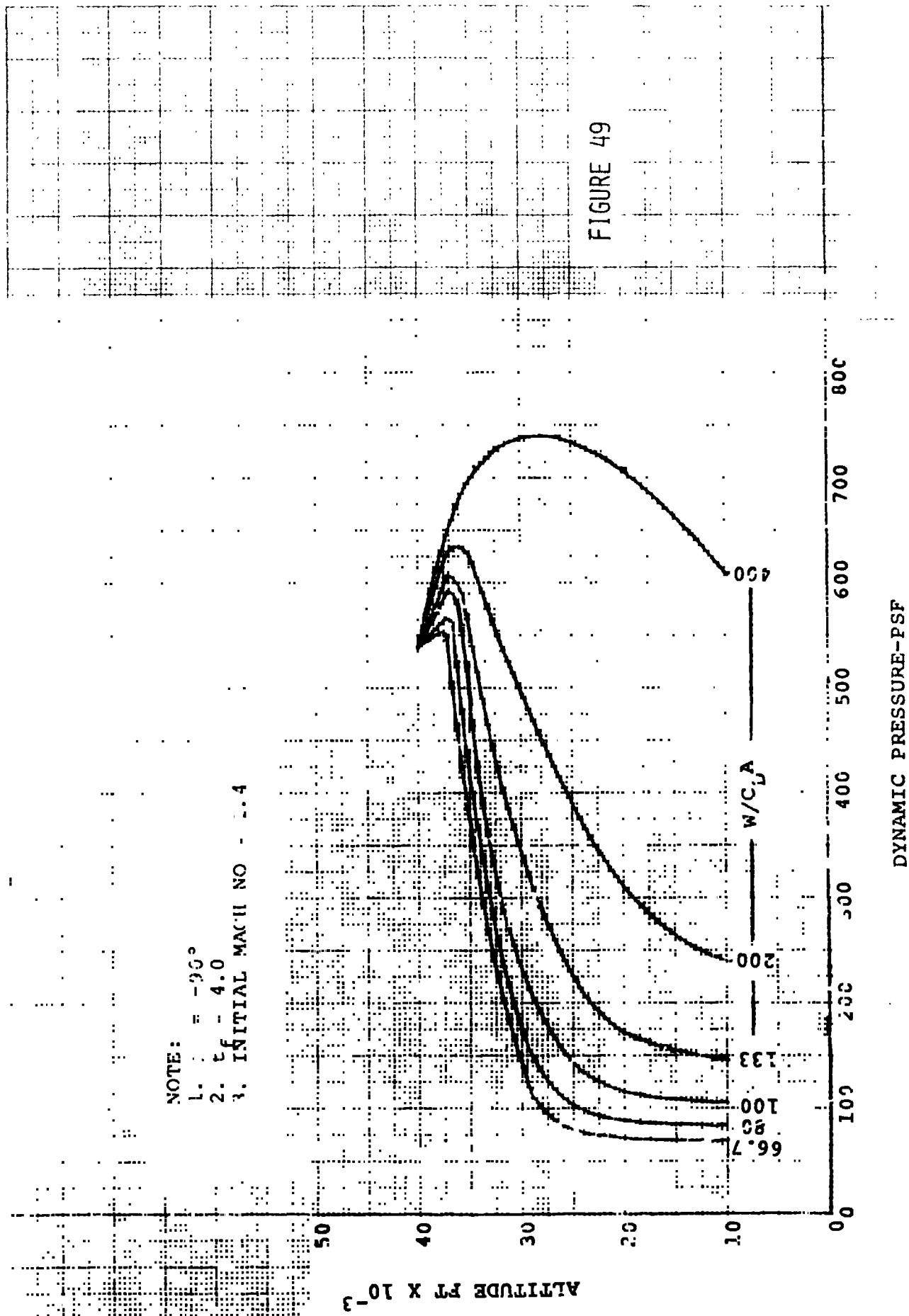
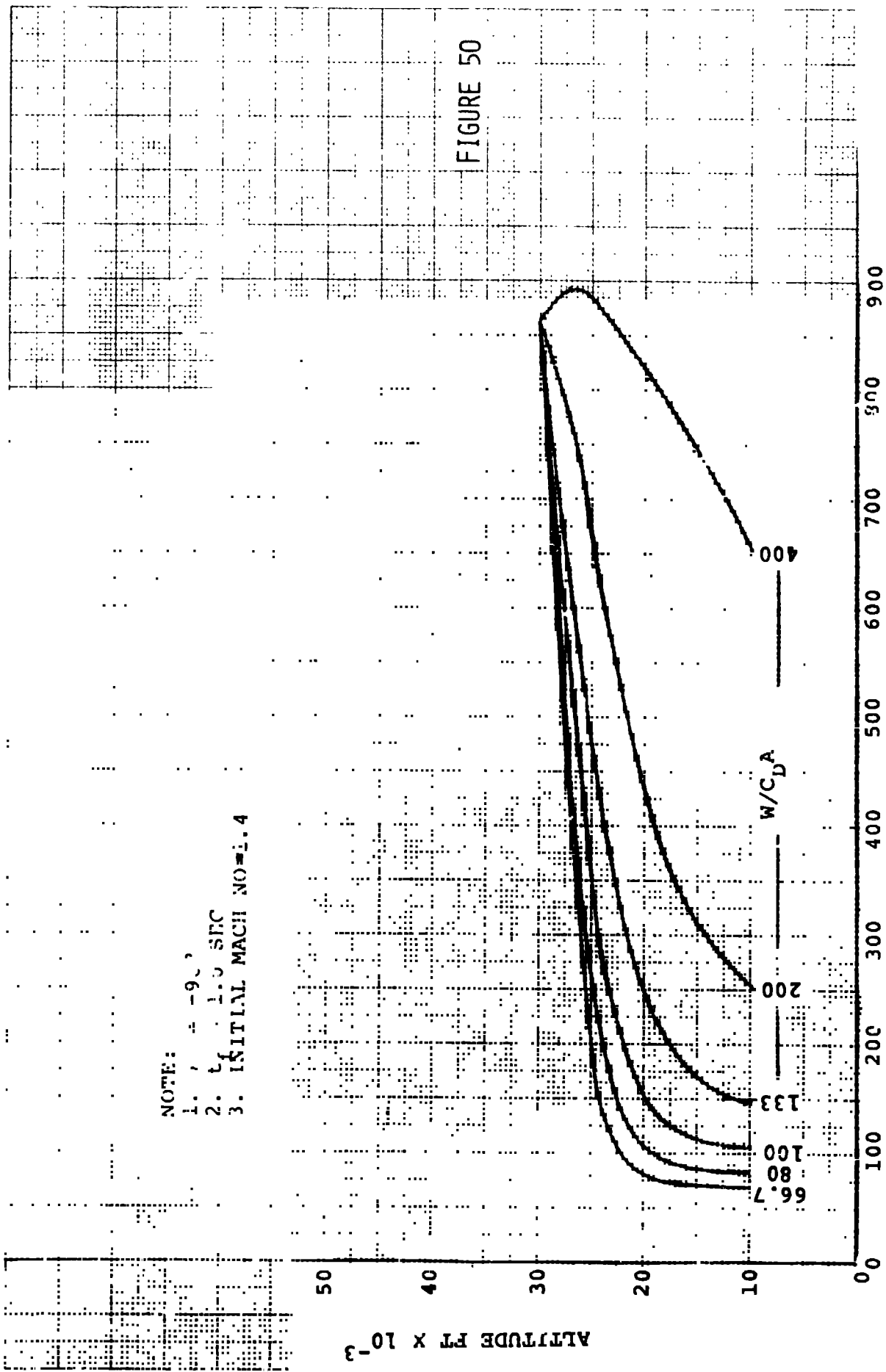

FIGURE 49



NOTE:
 1. $\gamma = -90^\circ$
 2. $t = 1.0$ SEC
 3. INITIAL MACH NO = 1.4

FIGURE 50

DYNAMIC PRESSURE-PSF

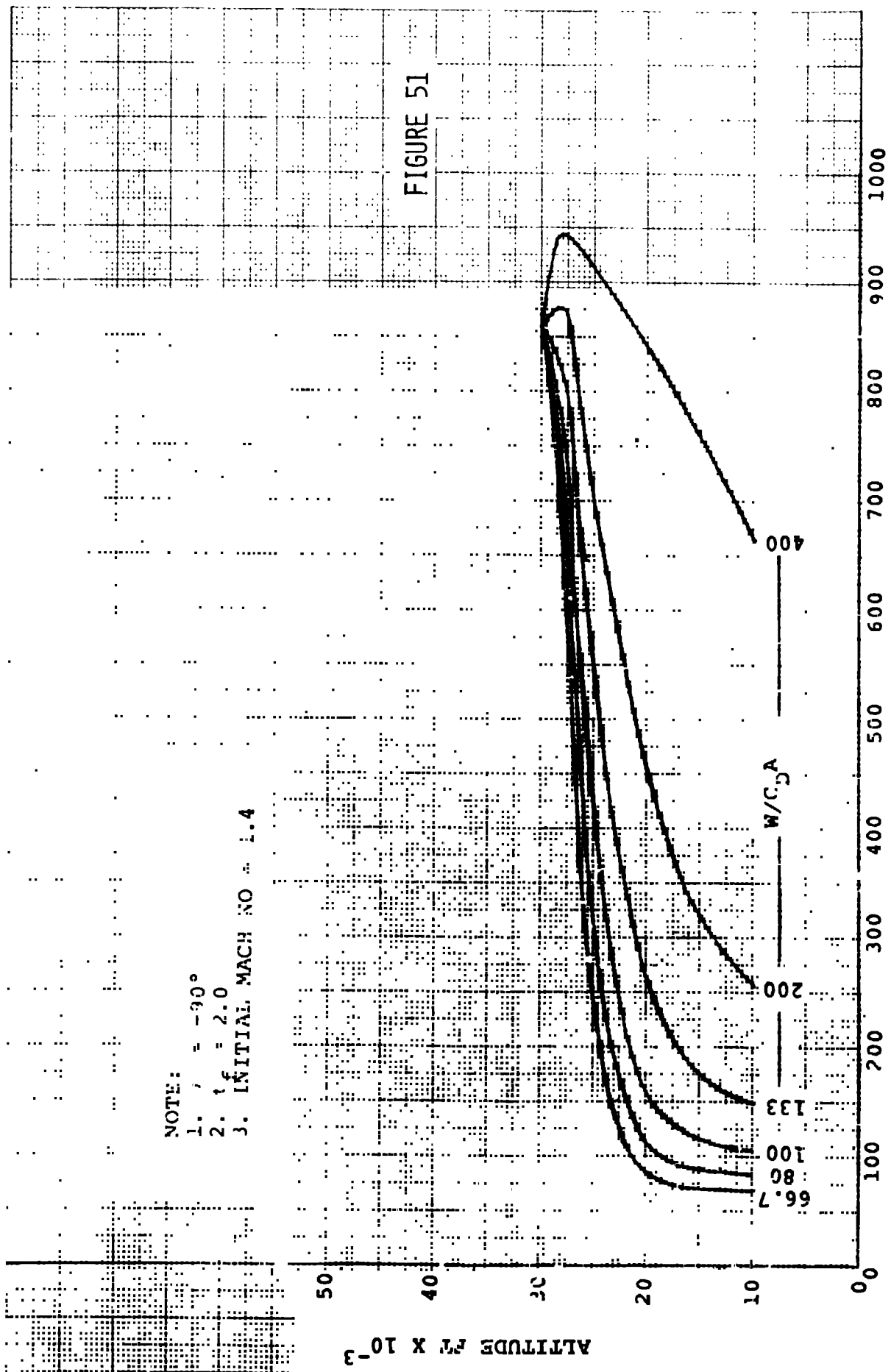

NOTE:

1. $\gamma = -90^\circ$
2. $\epsilon = 2.0$
3. INITIAL MACH NO = 1.4

FIGURE 51

DYNAMIC PRESSURE-PSF

NOTE:

- 1. $\gamma = -90^\circ$
- 2. $L_c = 4.0$
- 3. INITIAL MACH NO = 2.4

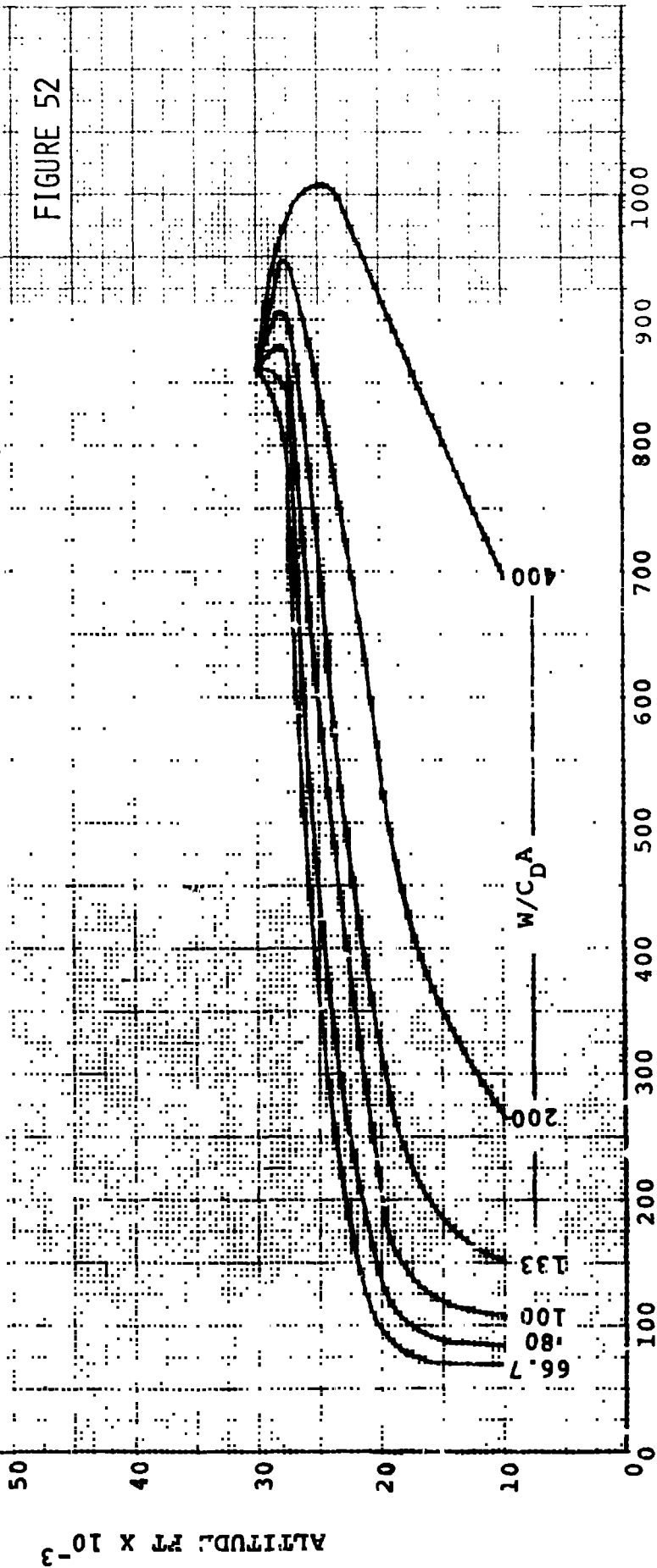

ALTITUDE FT X 10⁻³

DYNAMIC PRESSURE-PSF

FIGURE 52

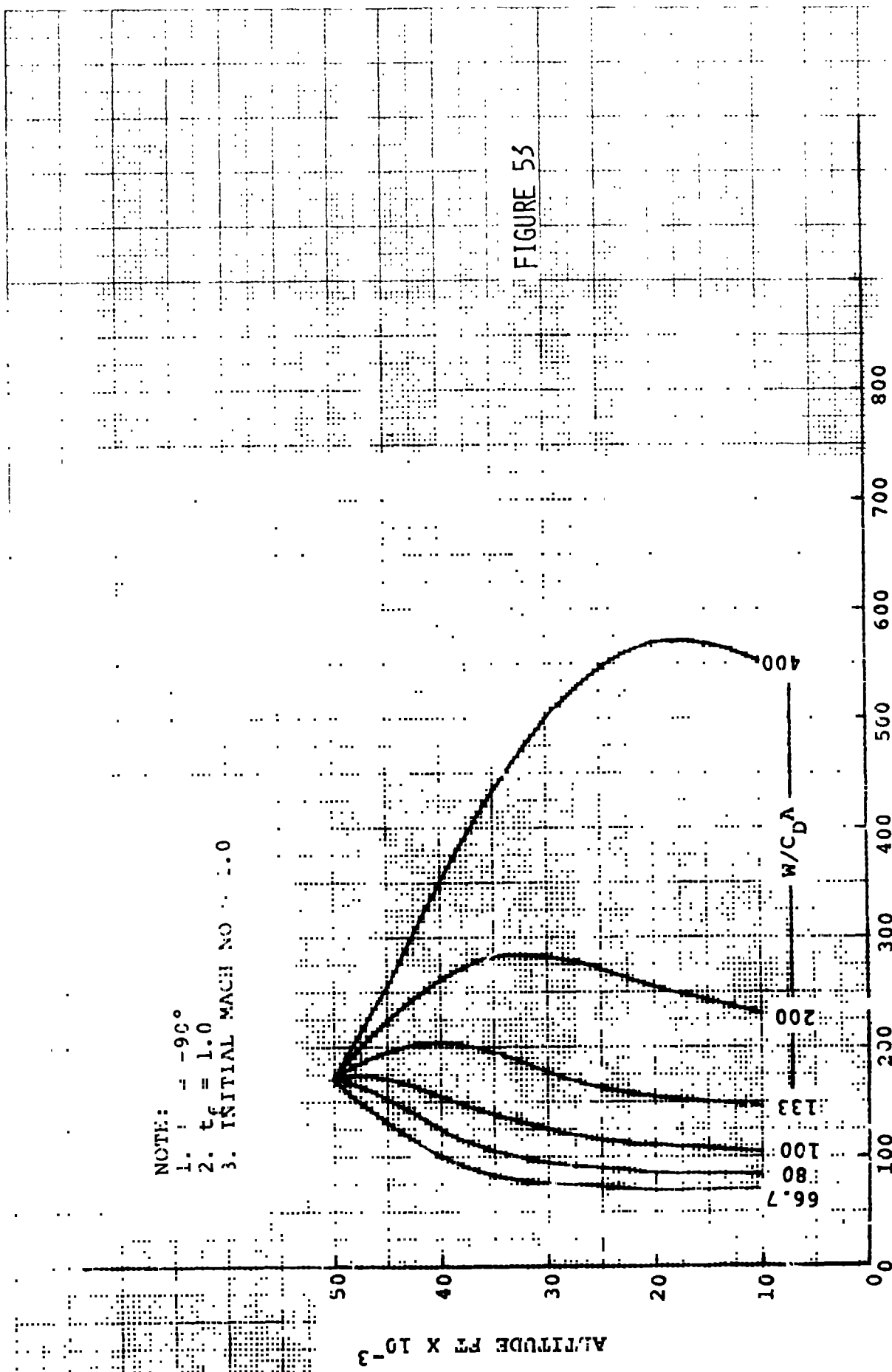

FIGURE 53

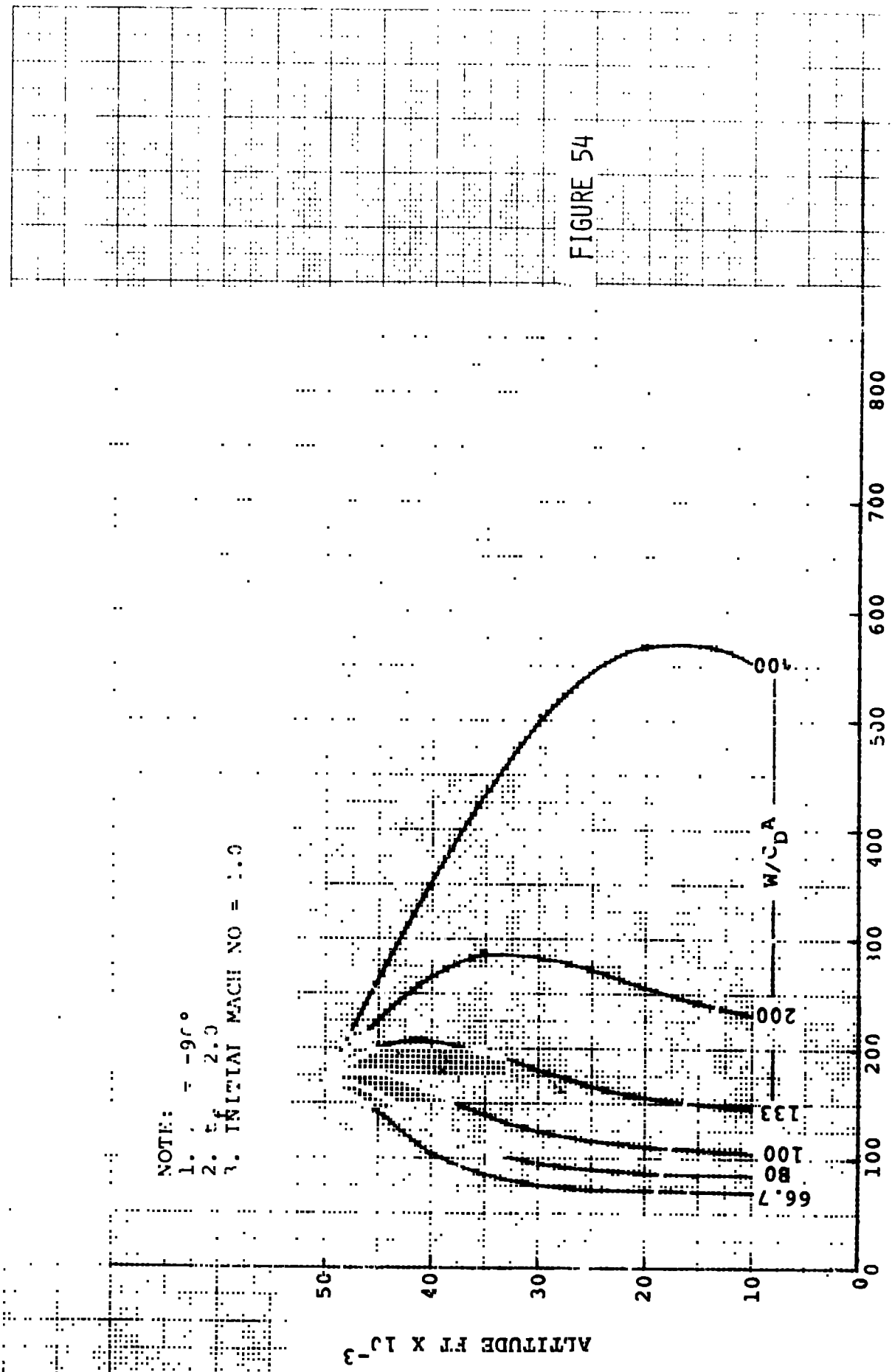

FIGURE 54

NOTE:
 1. $\alpha = -30^\circ$
 2. $\beta = 4.0$
 3. INITIAL MACH NO = 1.0

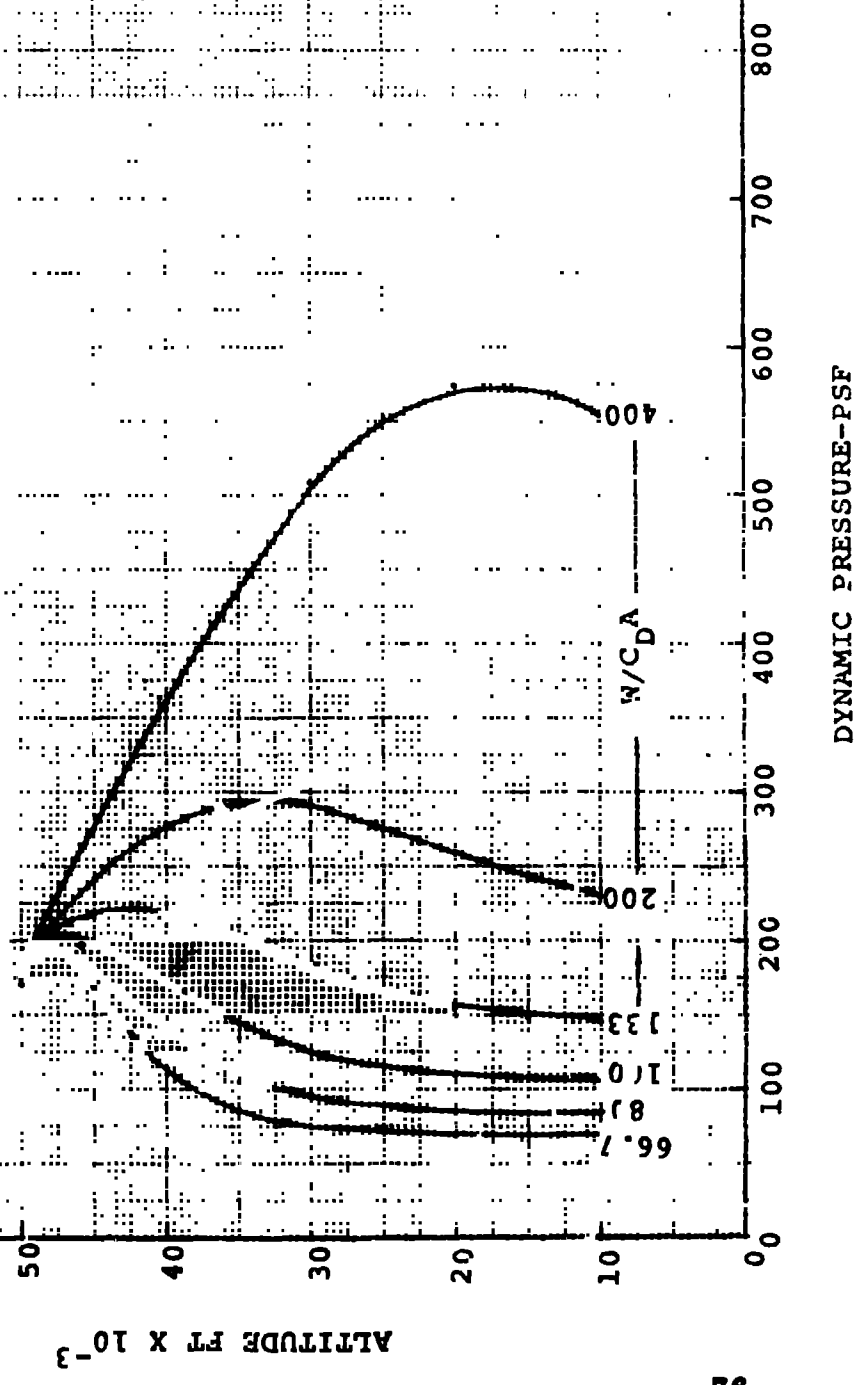

FIGURE 55

NOTE:
 1. $\gamma = -90^\circ$
 2. $t_c = 1.0$
 3. INITIAL MACH NO = 1.0

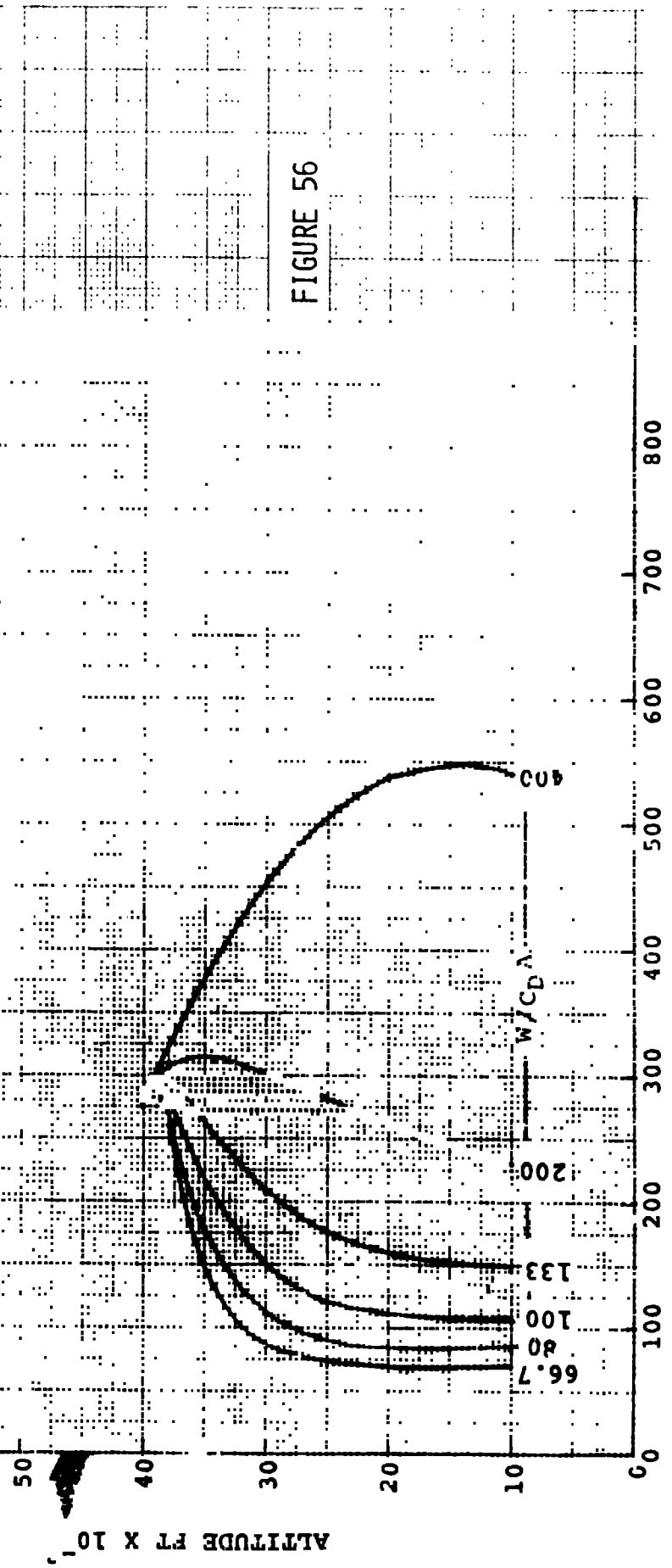

FIGURE 56

DYNAMIC PRESSURE-PSF

NOTE:

1. $\gamma = -90^\circ$
2. $t_f = 2.0$
3. INITIAL MACH NC = 1.0

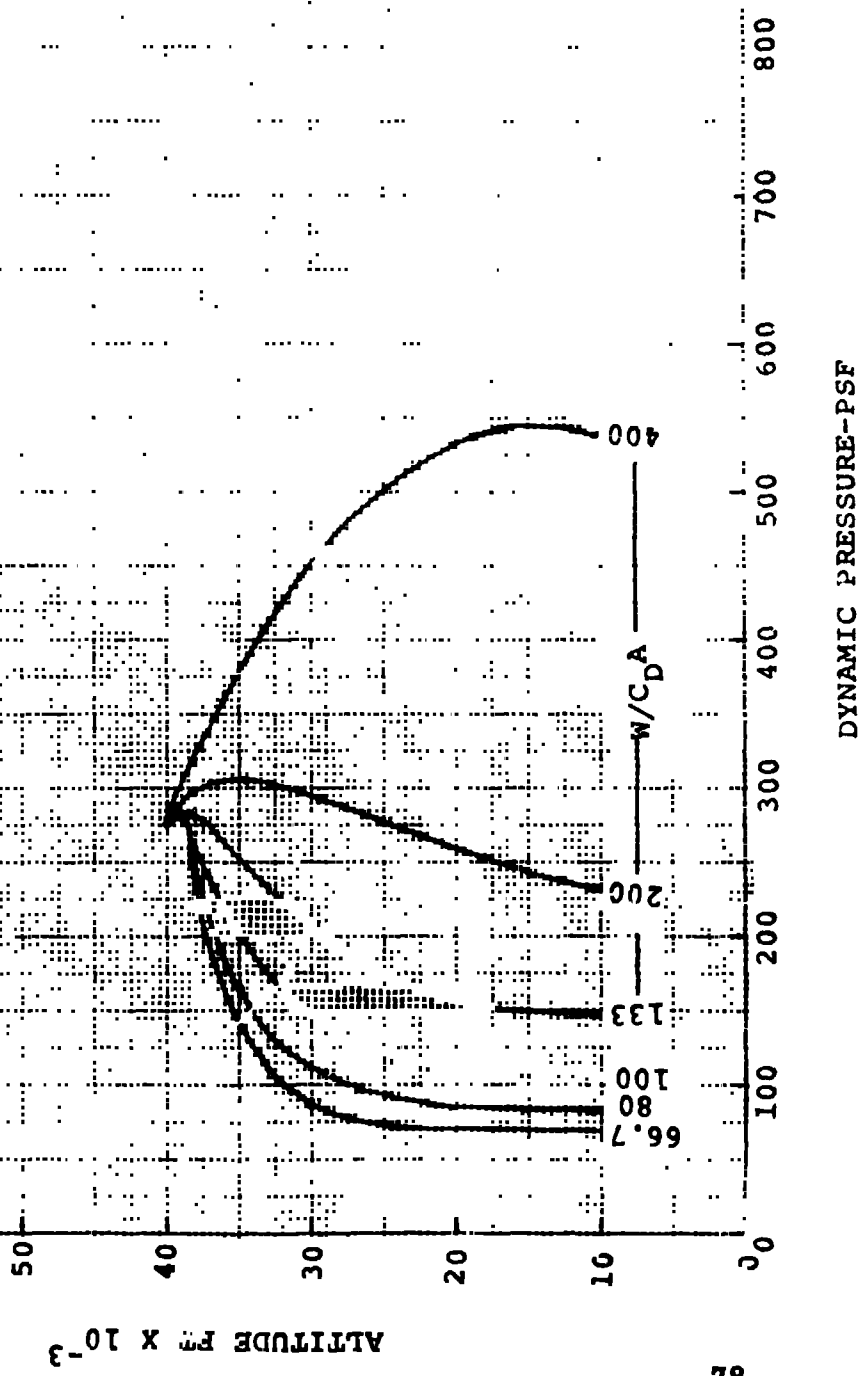
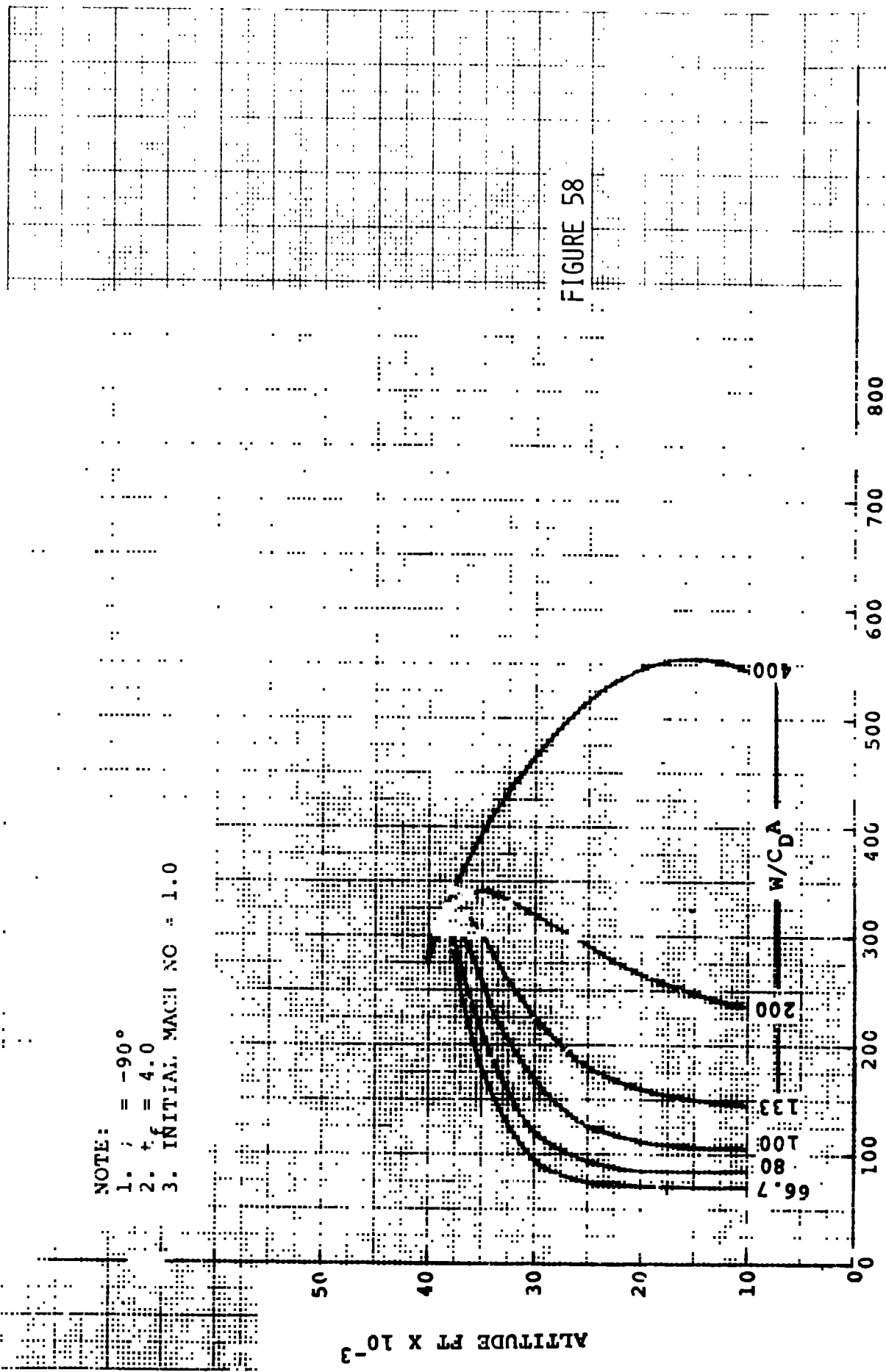

FIGURE 57



- NOTE:
1. $\gamma = -90^\circ$
 2. $t_f = 4.0$
 3. INITIAL MACH NO = 1.0

FIGURE 58

DYNAMIC PRESSURE-PSF

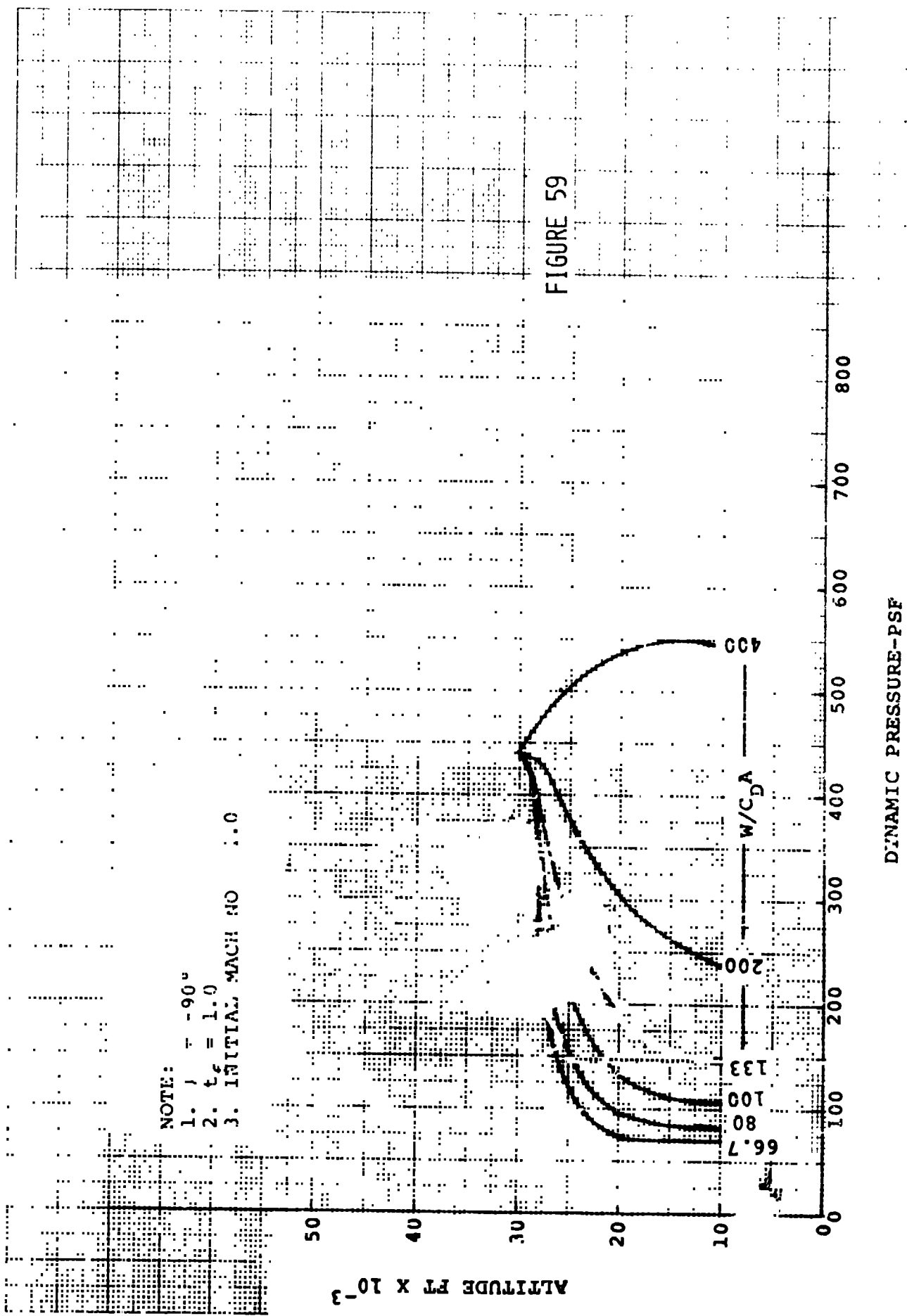

FIGURE 59

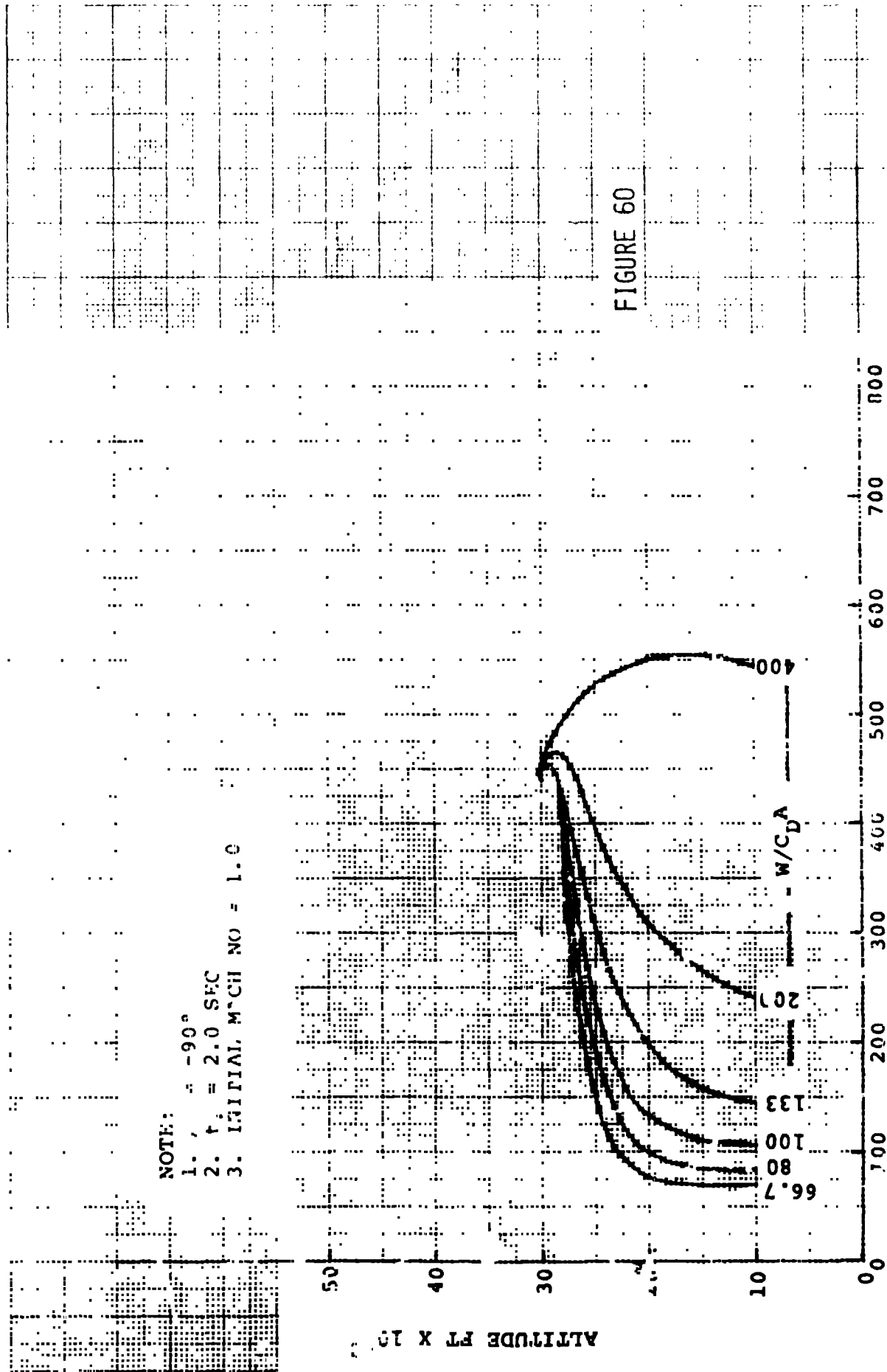

FIGURE 60

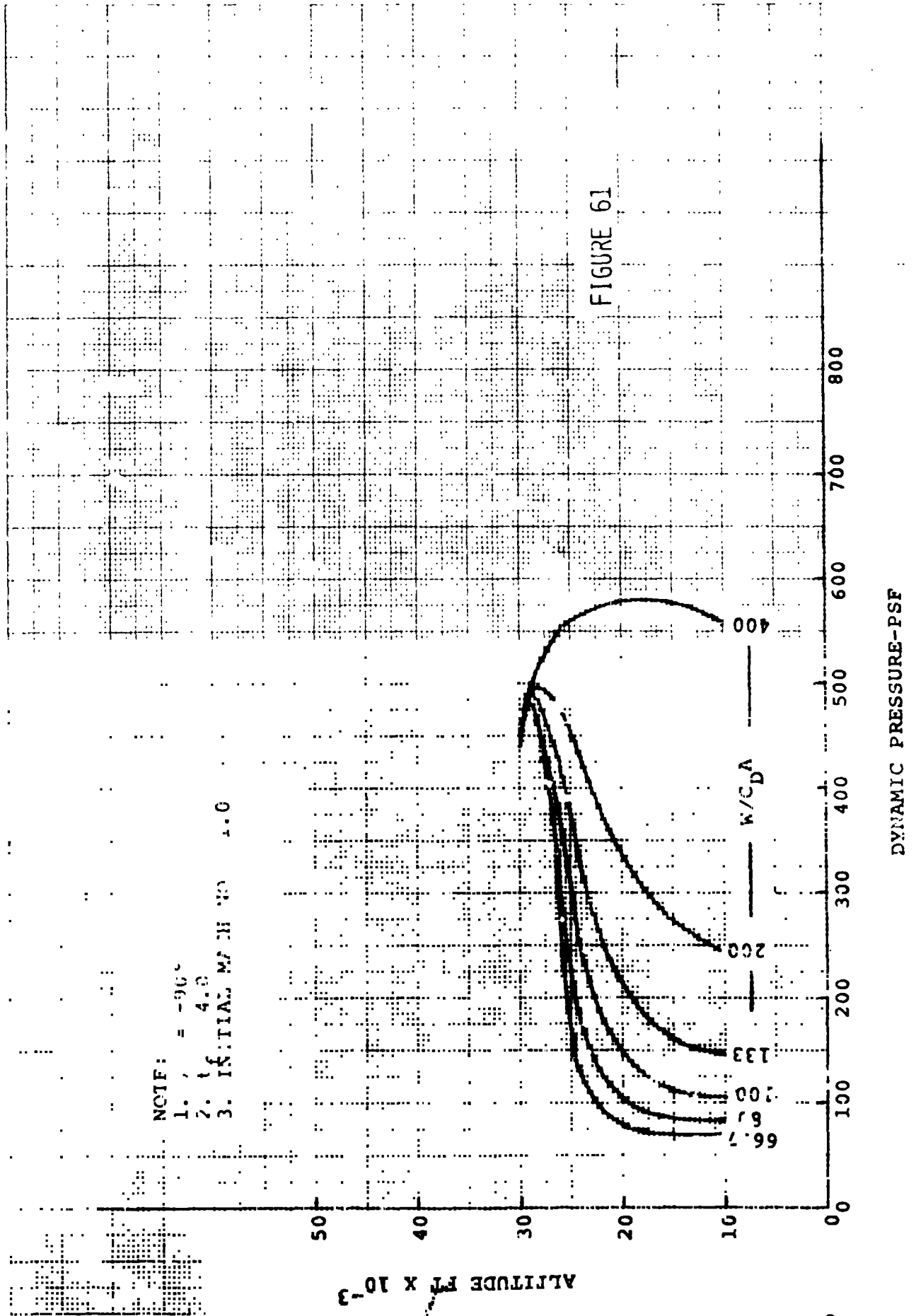

FIGURE 61

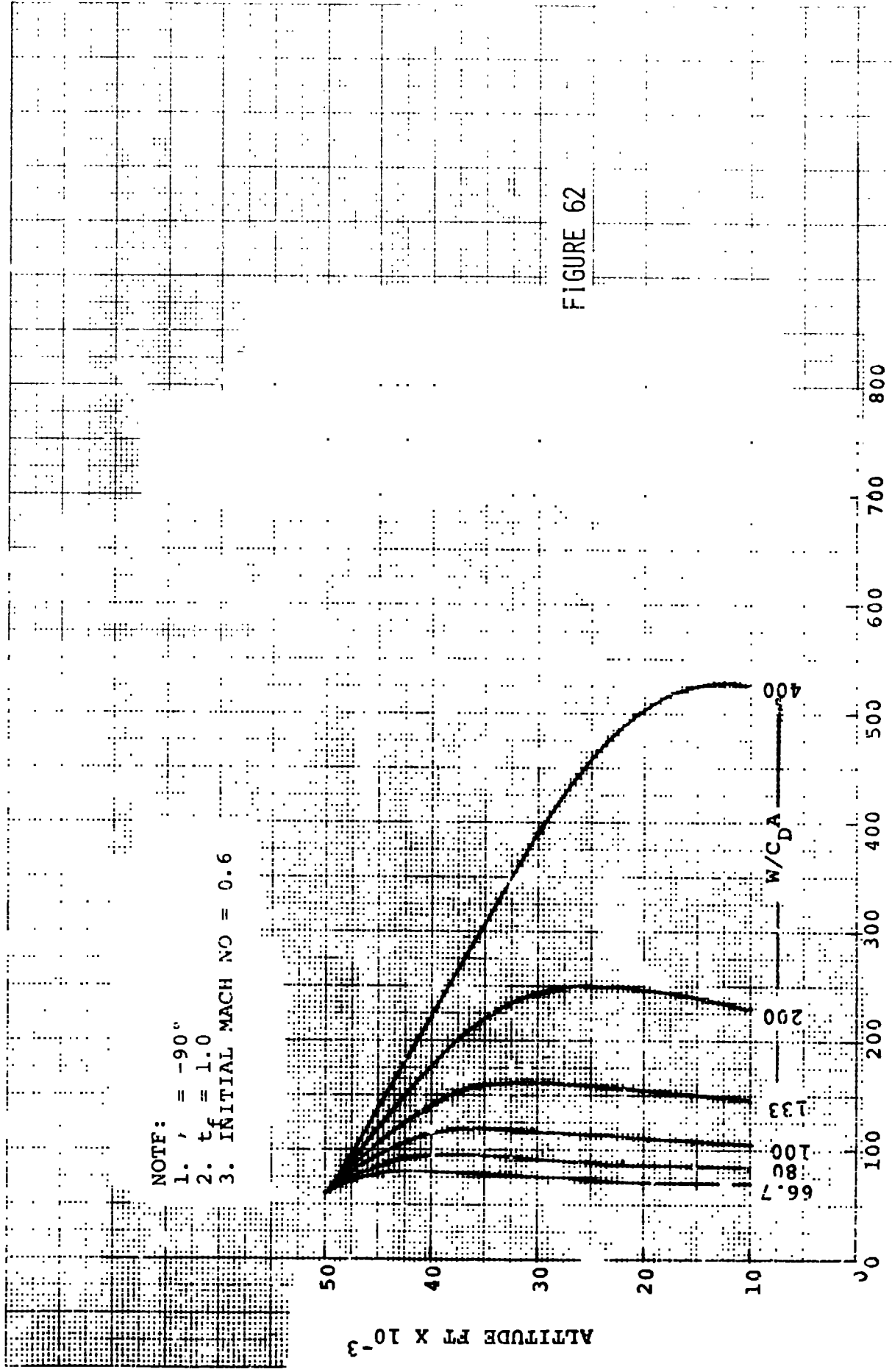

FIGURE 62

DYNAMIC PRESSURE-PSF

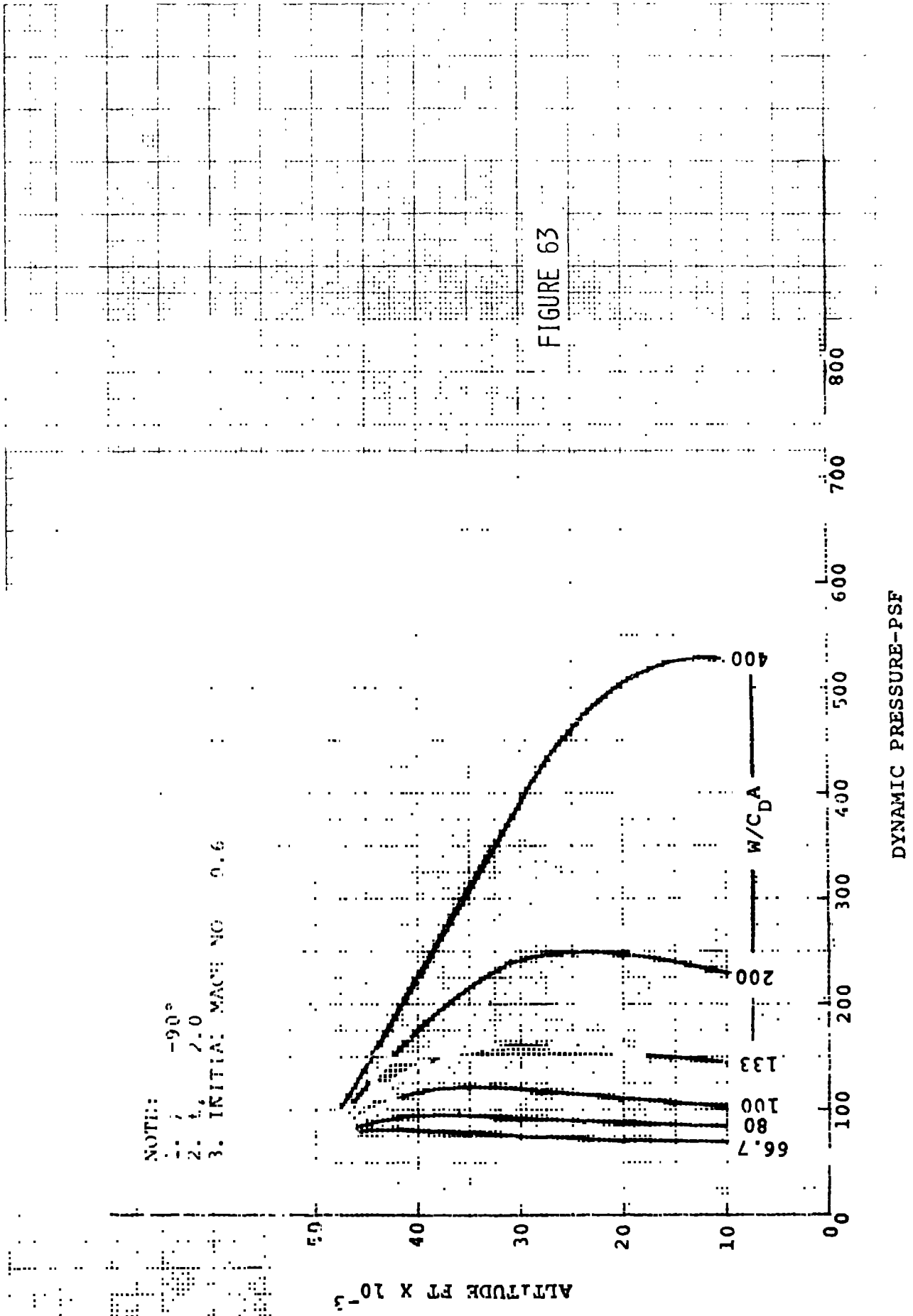

FIGURE 63

NOTE:

1. $\gamma = -90^\circ$
2. $t_f = 4.0$
3. INITIAL MACH NO. = 0.6

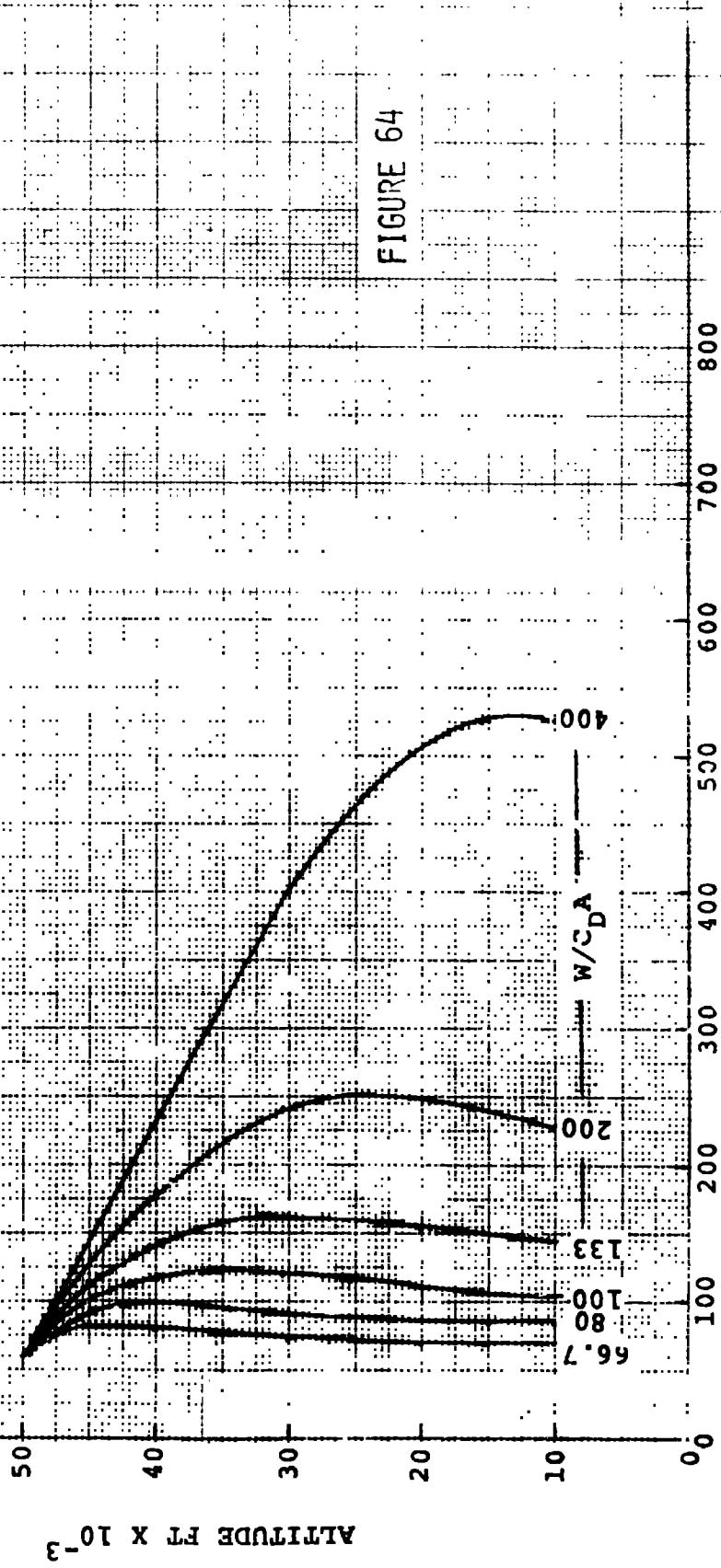
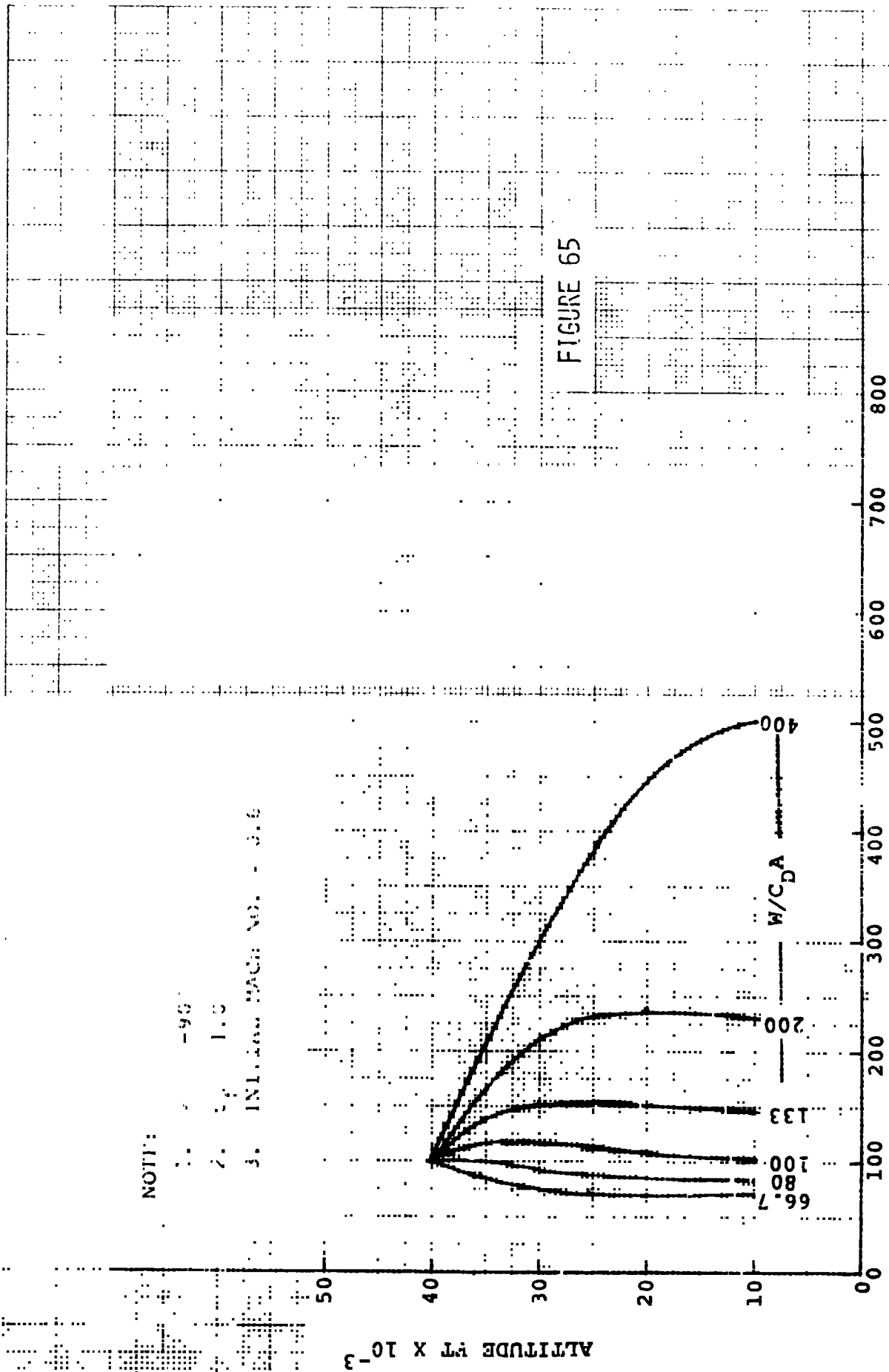
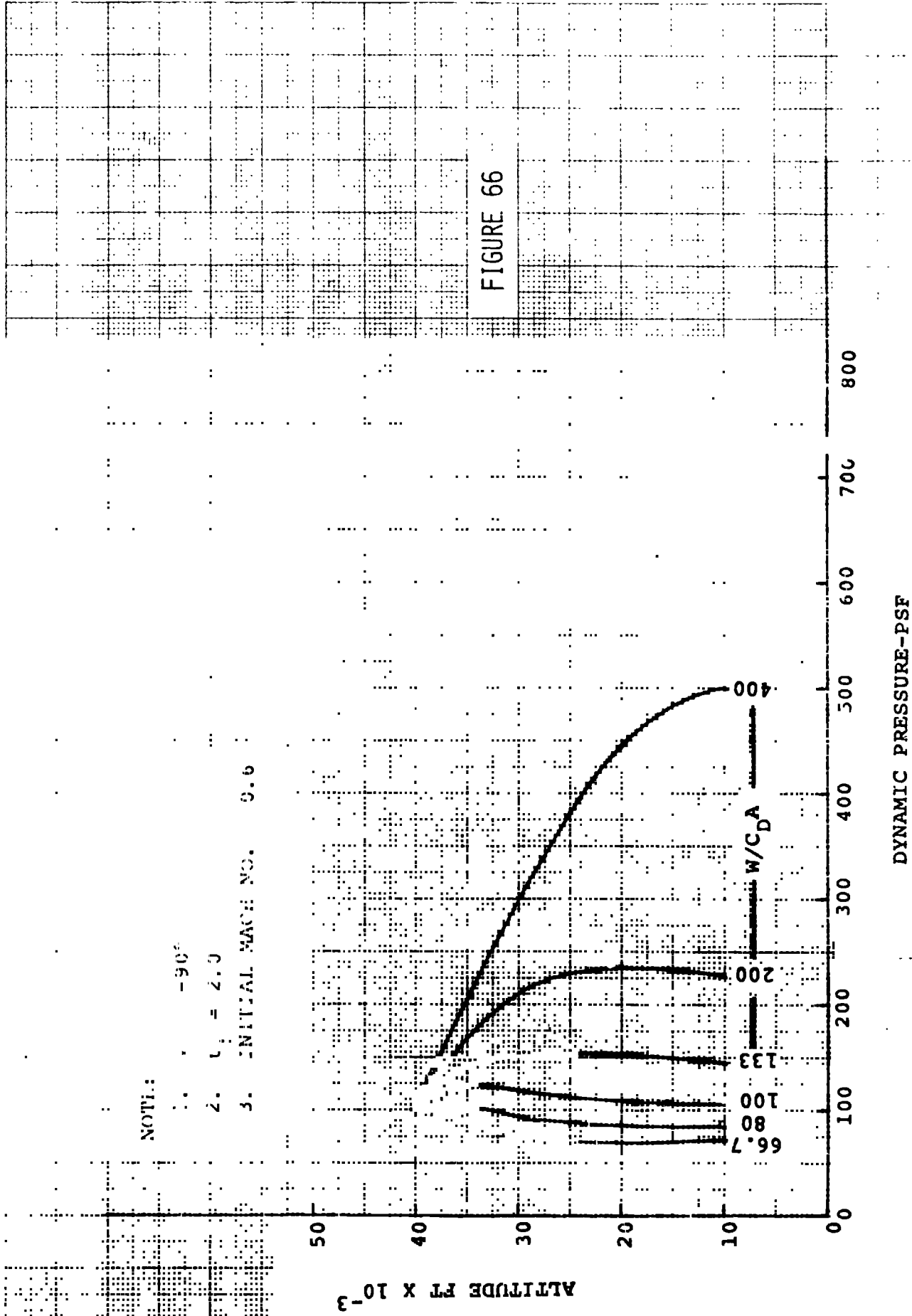
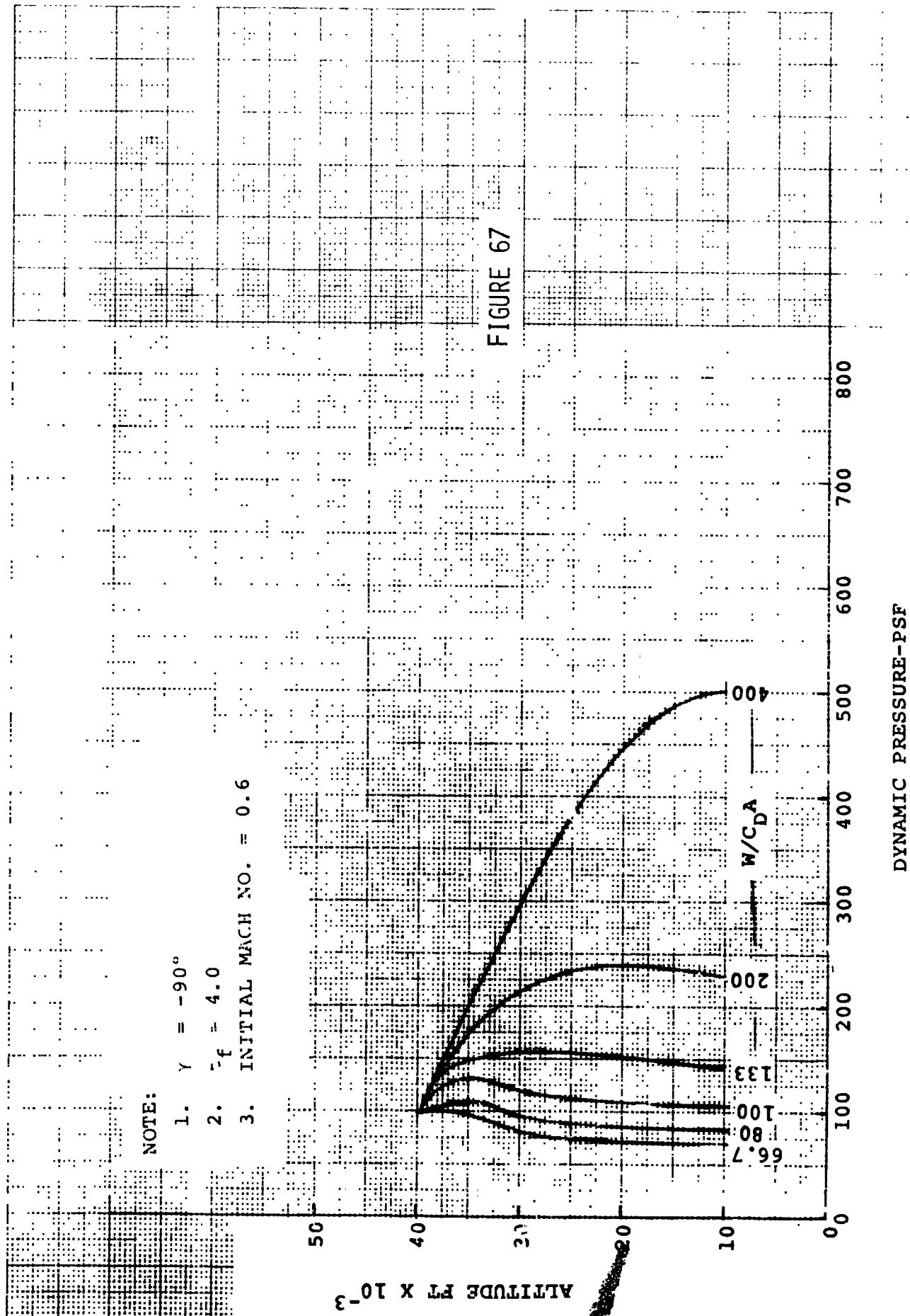

FIGURE 64

DYNAMIC PRESSURE-PSF







NOTE:

1. $\gamma = -90^\circ$
2. $\tau_f = 4.0$
3. INITIAL MACH NO. = 0.6

FIGURE 67

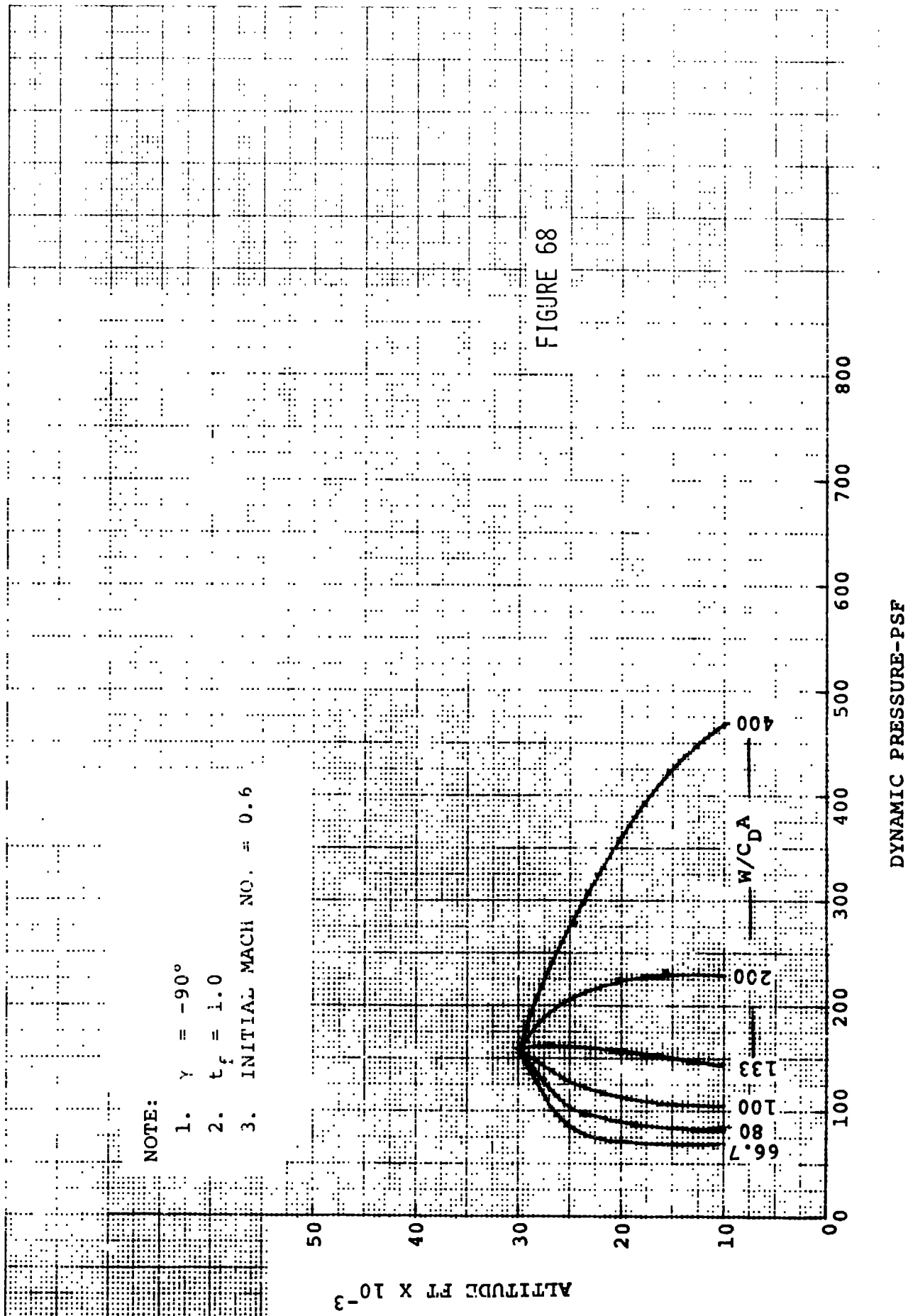

NOTE:

1. $\gamma = -90^\circ$
2. $t_f = 1.0$
3. INITIAL MACH NO. = 0.6

FIGURE 68

NOTE:

- 1. $\gamma = 1.4$
- 2. $\beta = 2.0$
- 3. INITIAL MACH NO. 0.6

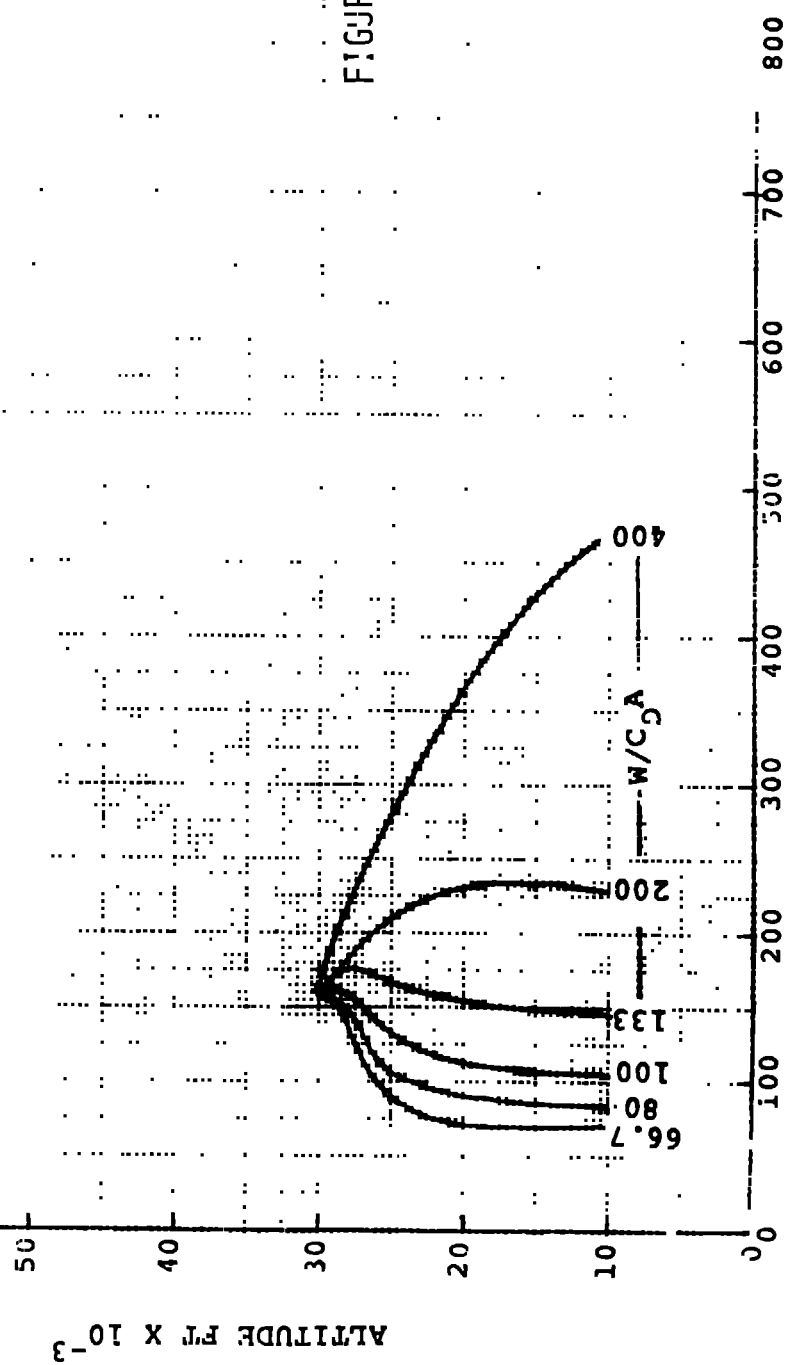

FIGURE 69

DYNAMIC PRESSURE-PSF

ALTITUDE FL X 10⁻³

NOTE:

1. $\gamma = -90^\circ$
2. $L_2 = 4.0$
3. INITIAL MACH NO. 0.6

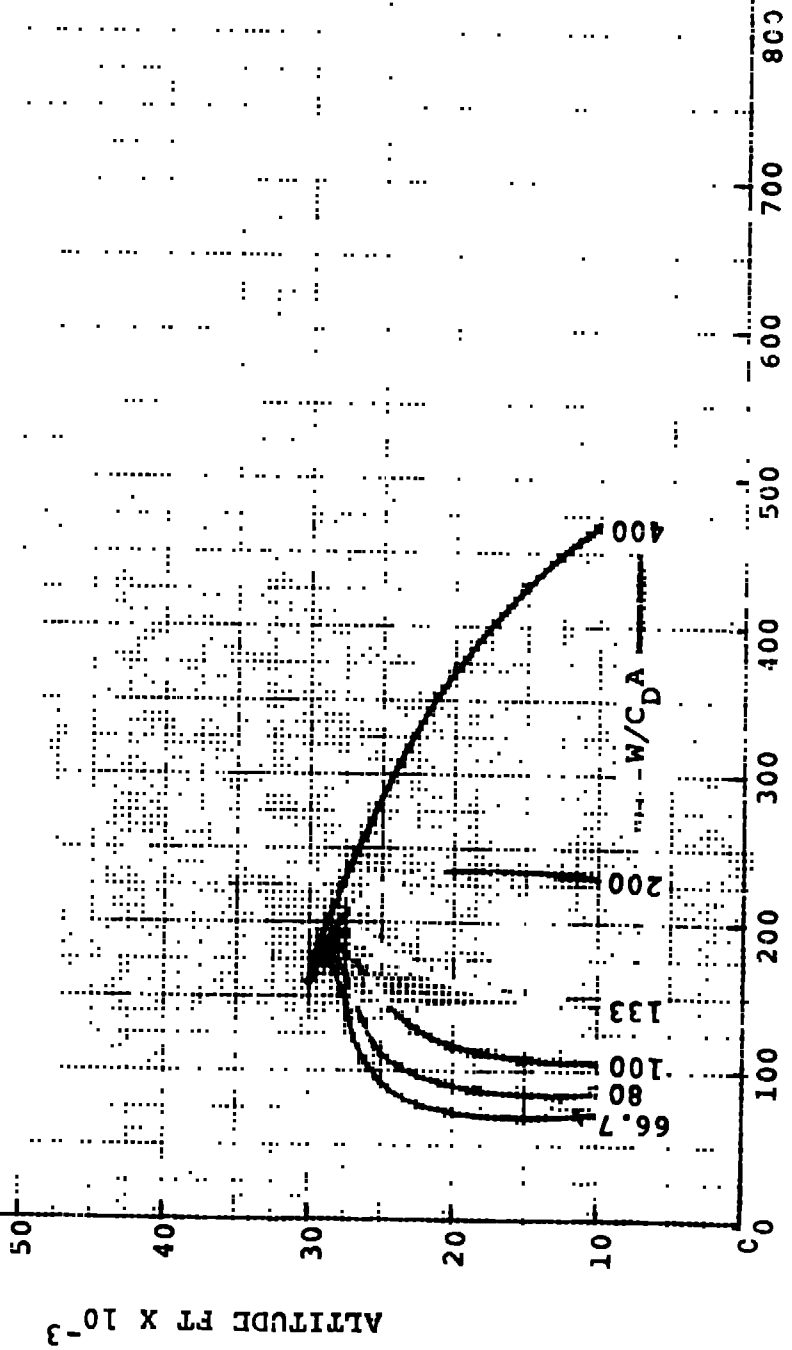
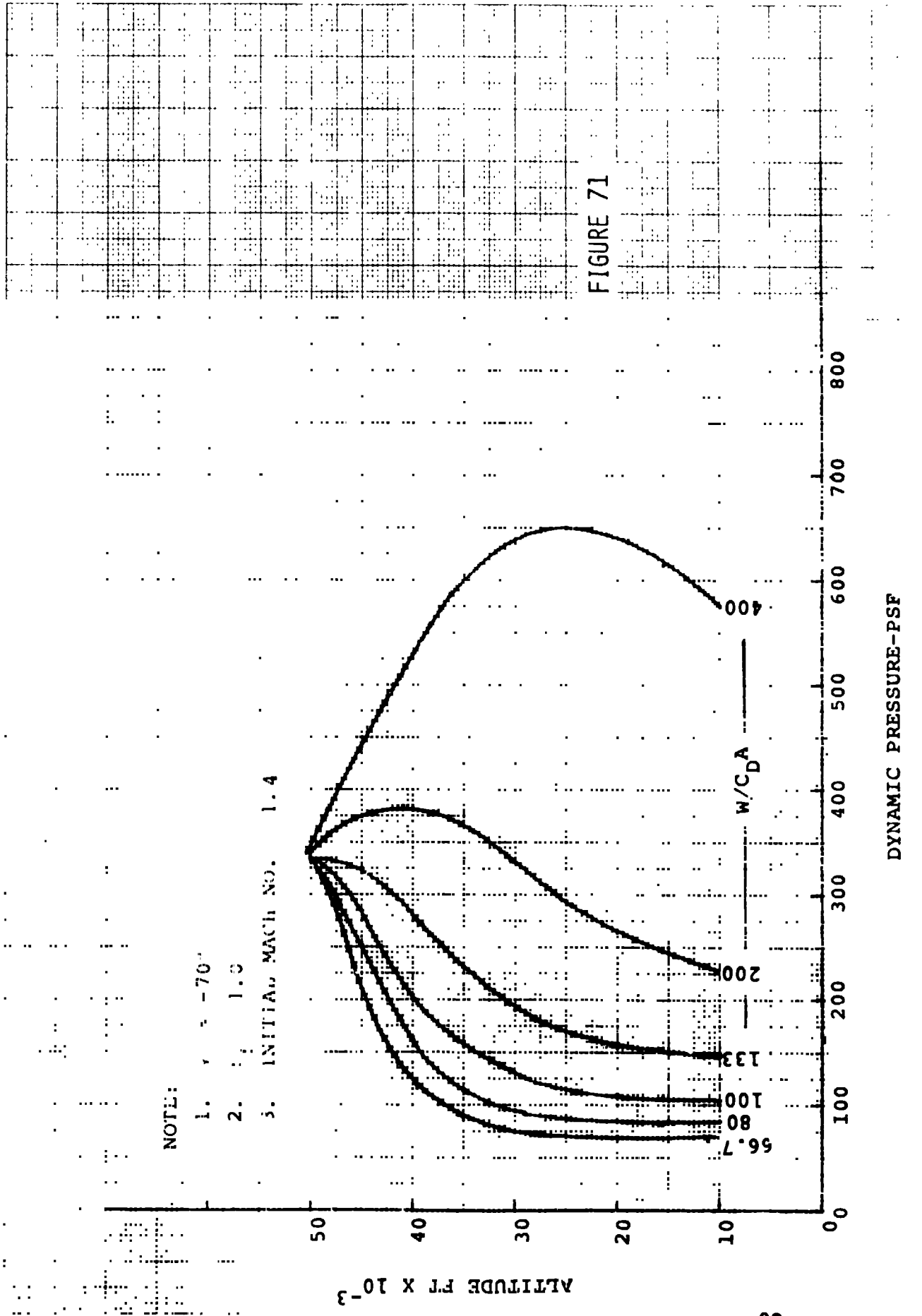

FIGURE 70

DYNAMIC PRESSURE--PSF

ALTITUDE FT X 10⁻³



NOTE:

1. $\gamma = -70^\circ$
2. $\beta = 1.0$
3. INITIAL MACH NO. 1.4

FIGURE 71

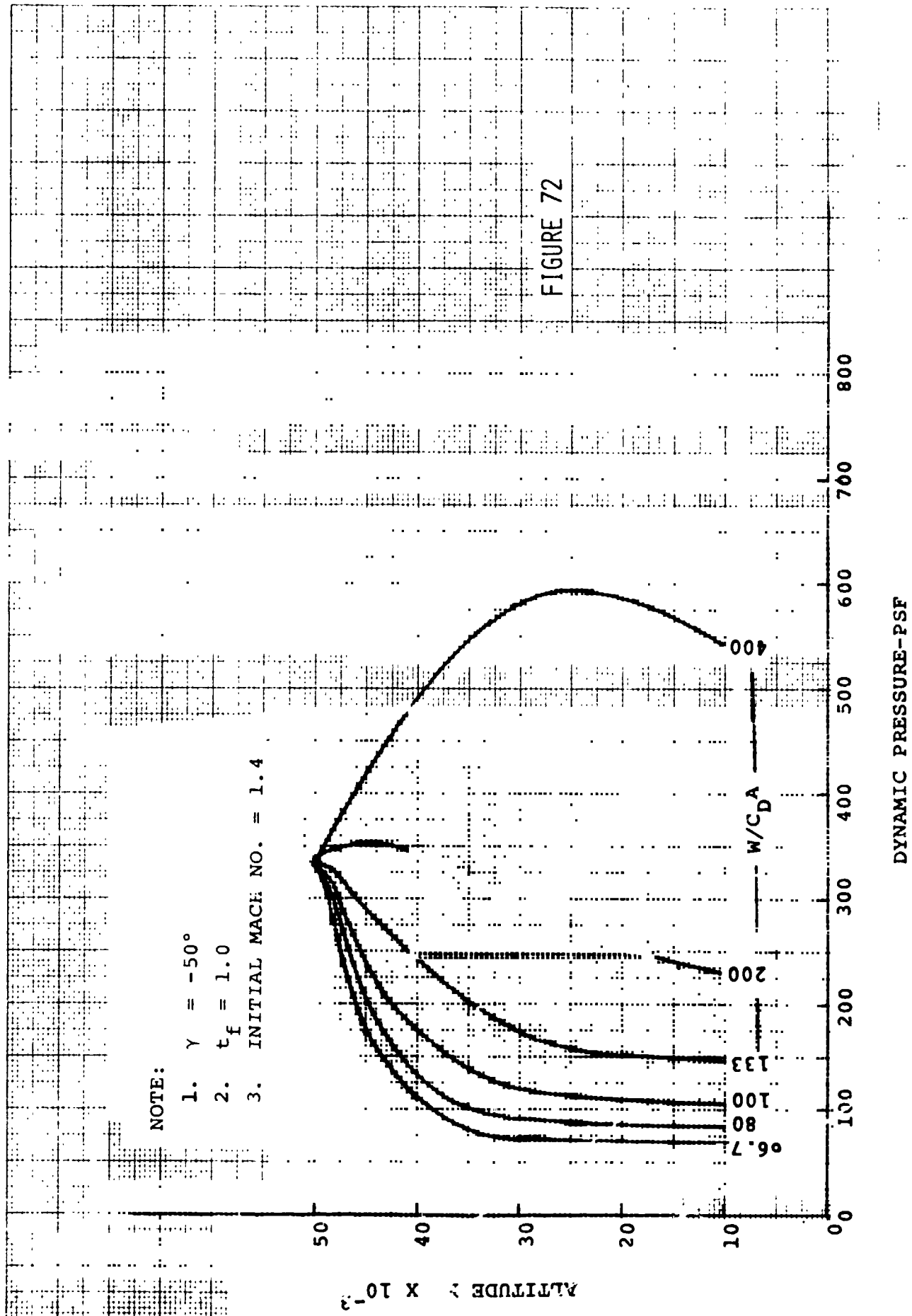

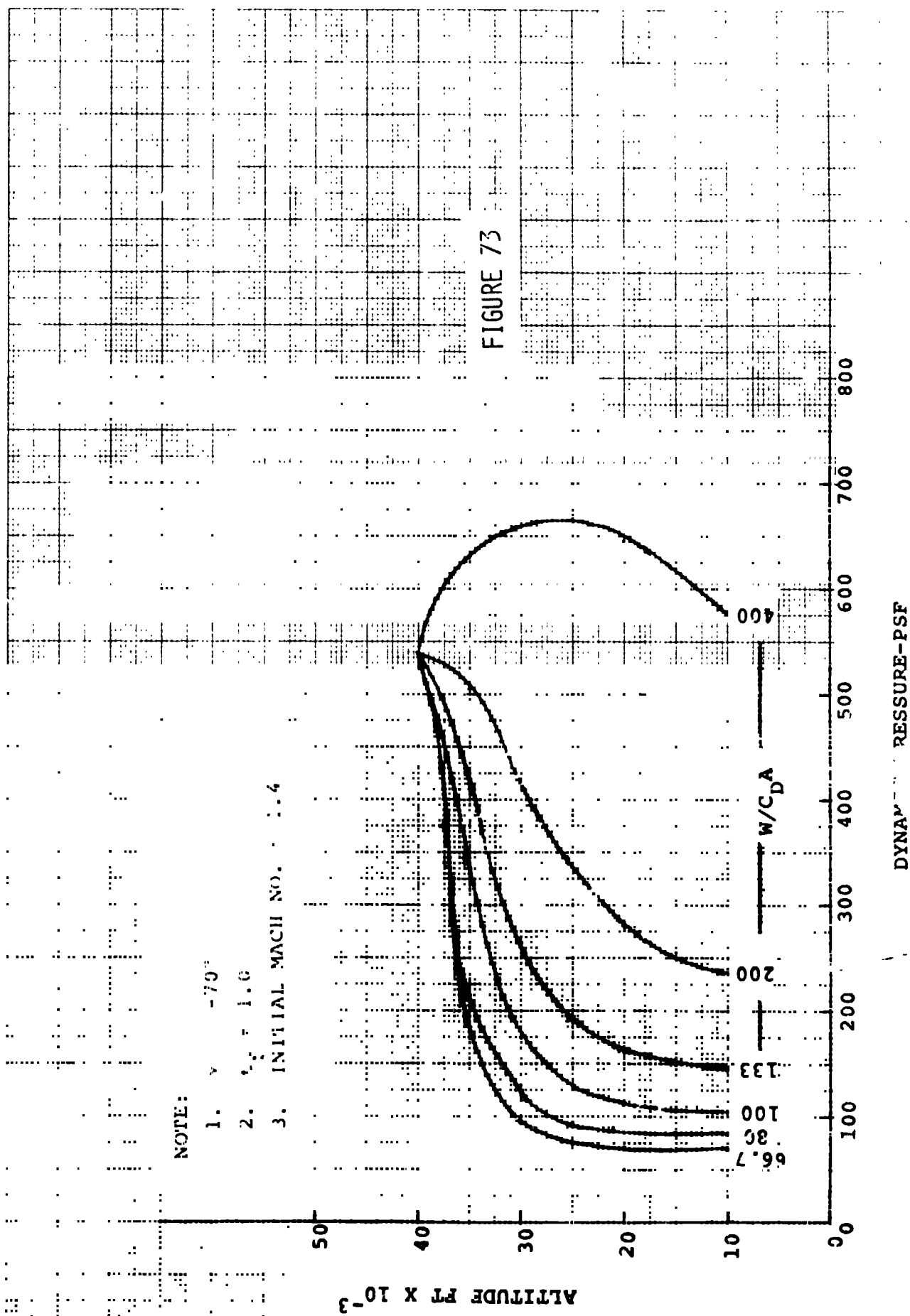
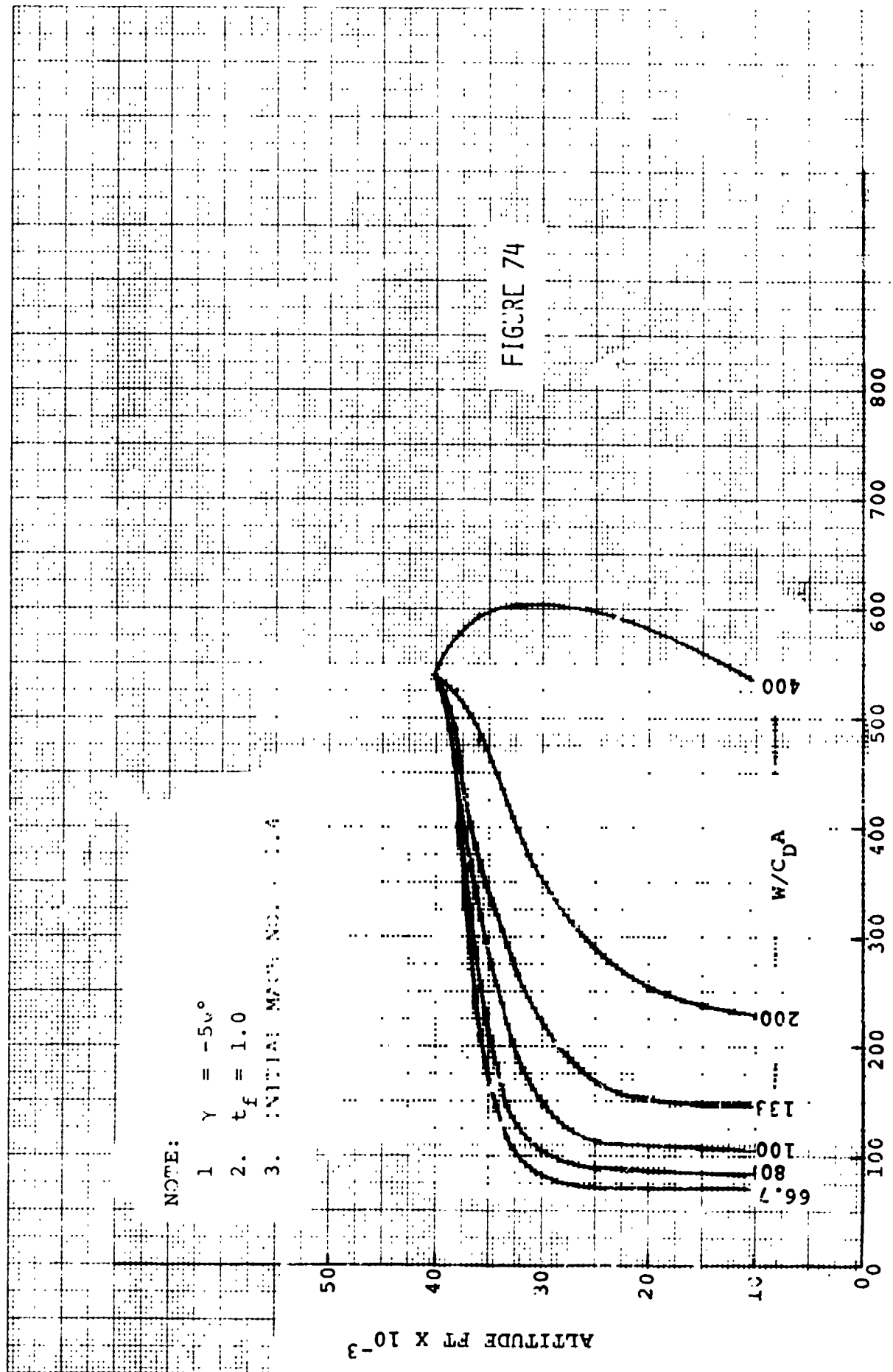

FIGURE 73



NOTE:

1. $\gamma = -5\omega^\circ$
2. $t_f = 1.0$
3. INITIAL MACH NO. = 1.4

FIGURE 74

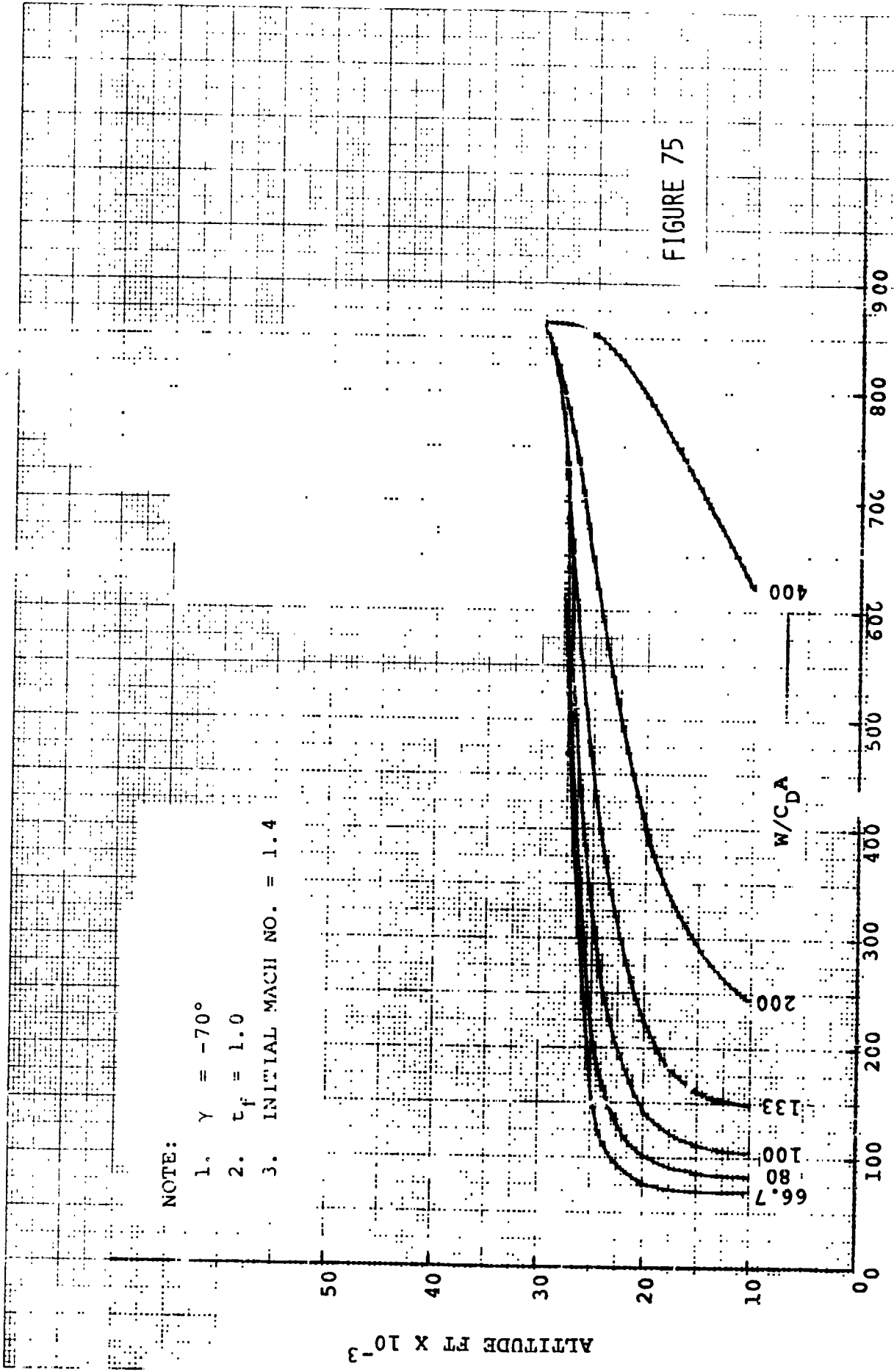
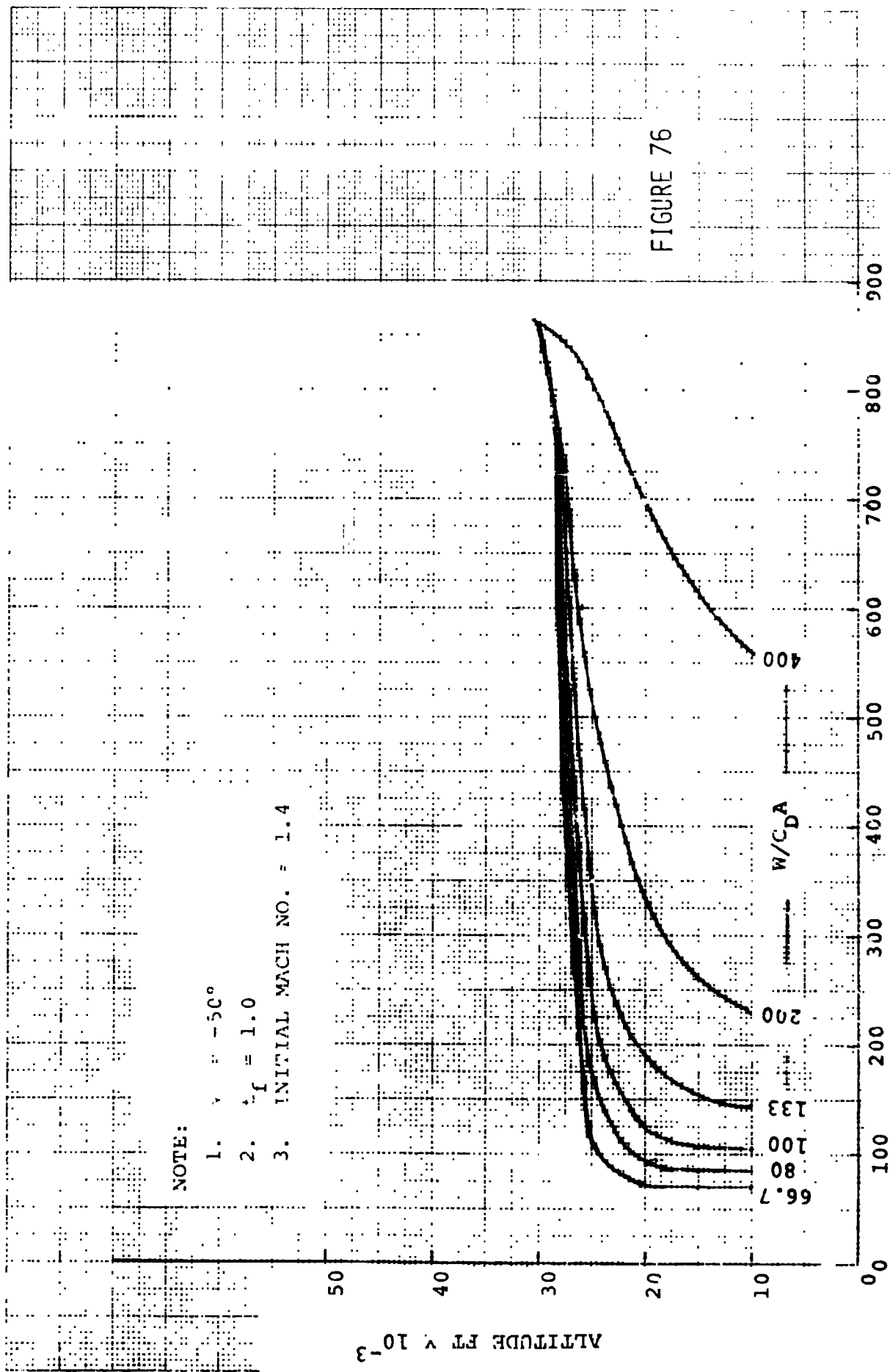

FIGURE 75



NOTE:

1. $\gamma = -50^\circ$
2. $t_f = 1.0$
3. INITIAL MACH NO. = 1.4

FIGURE 76

DYNAMIC PRESSURE-PSF

ALTITUDE FT x 10⁻³

W/C_D

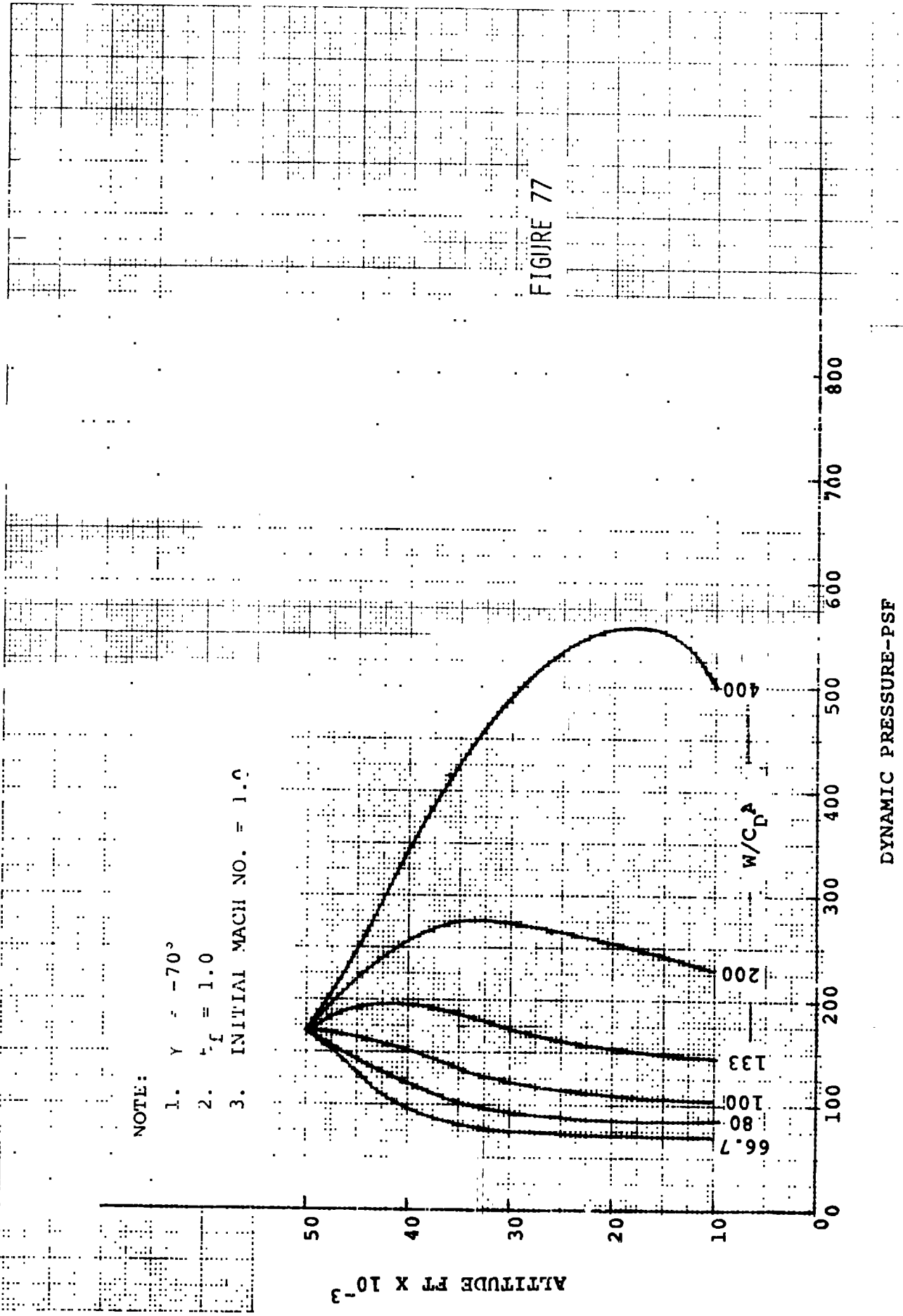

FIGURE 77

NOTE:

1. $\gamma = -50^\circ$
2. $t_f = 1.0$
3. INITIAL MACH NO. = 1.0

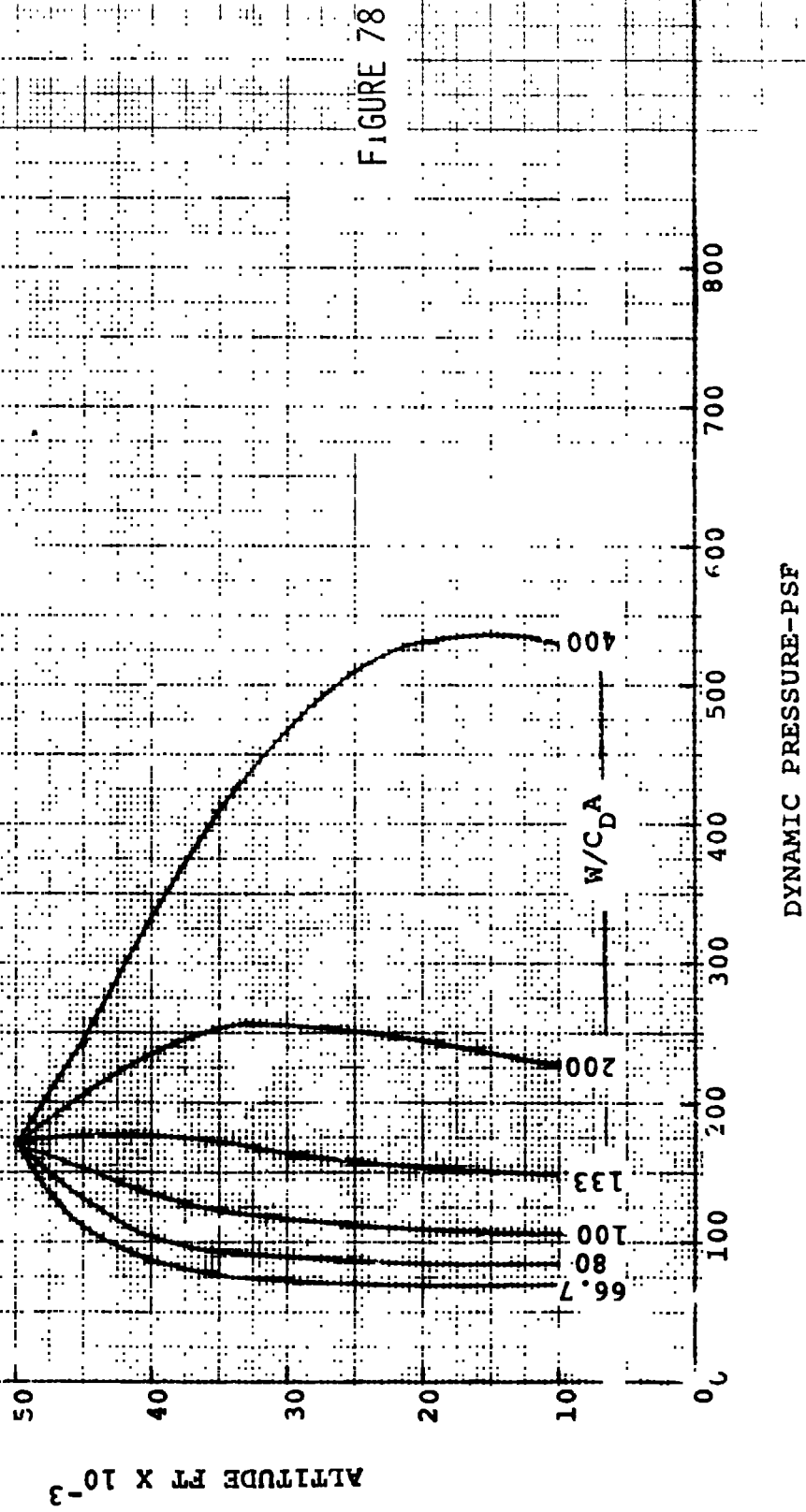
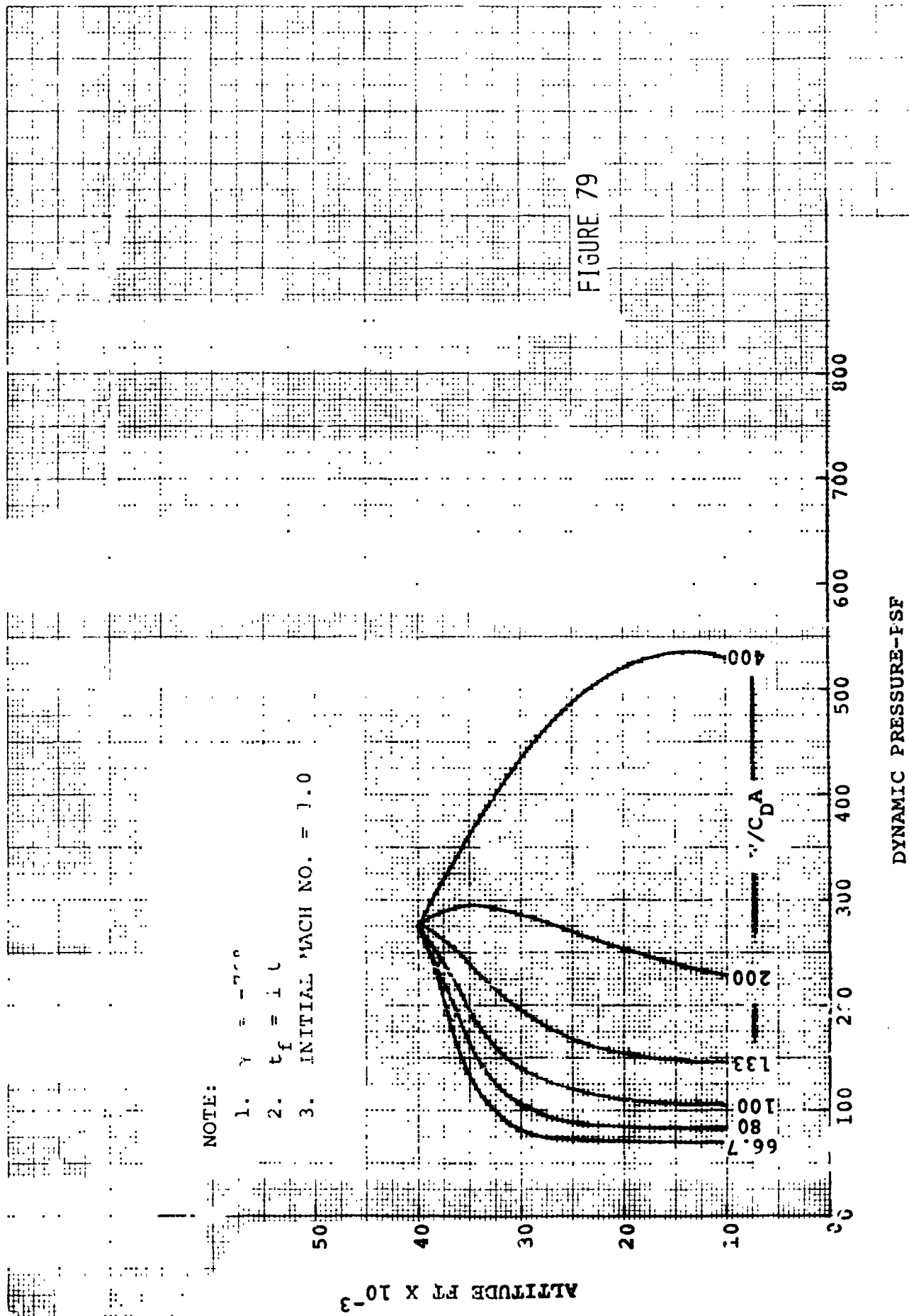

FIGURE 78



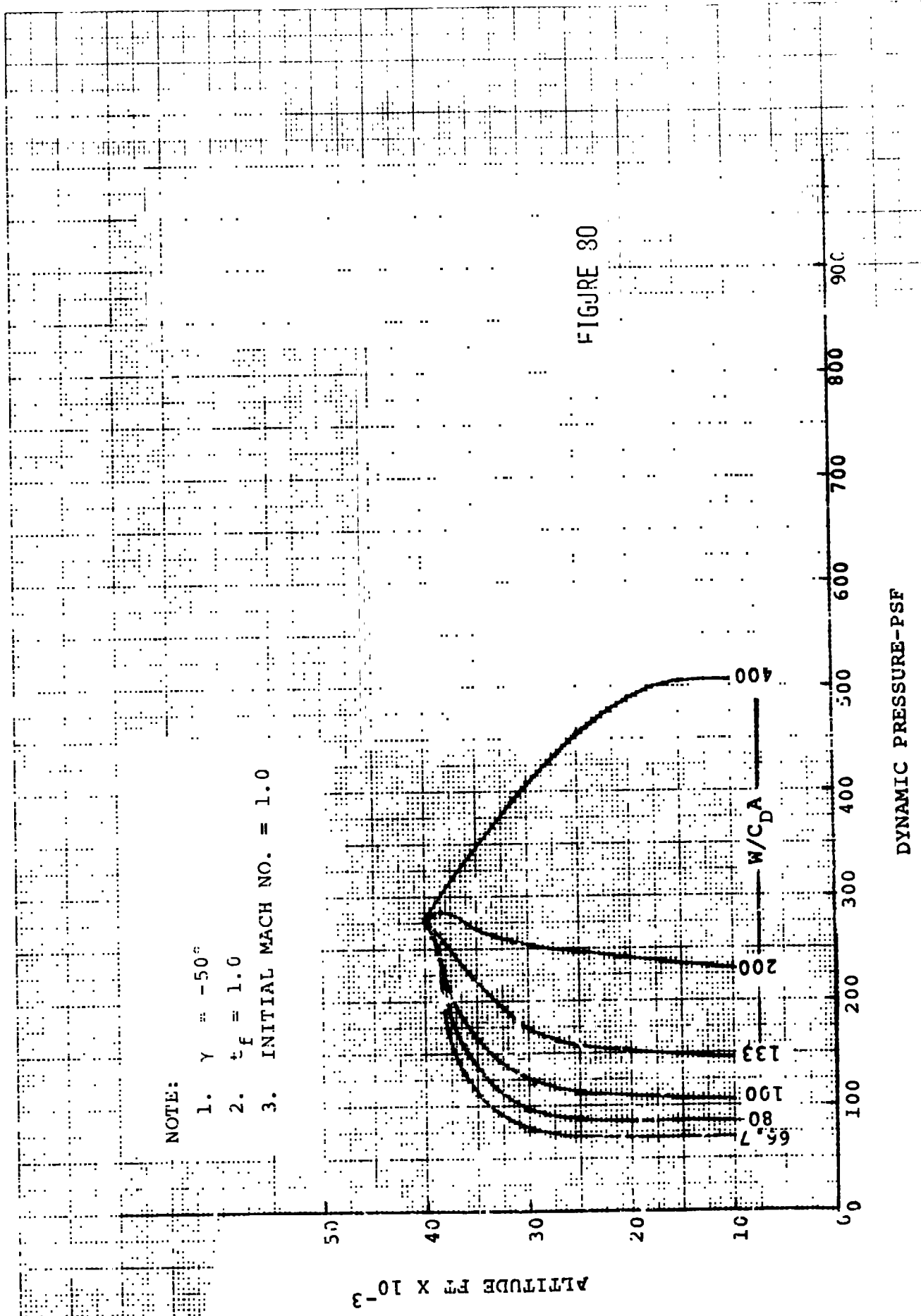
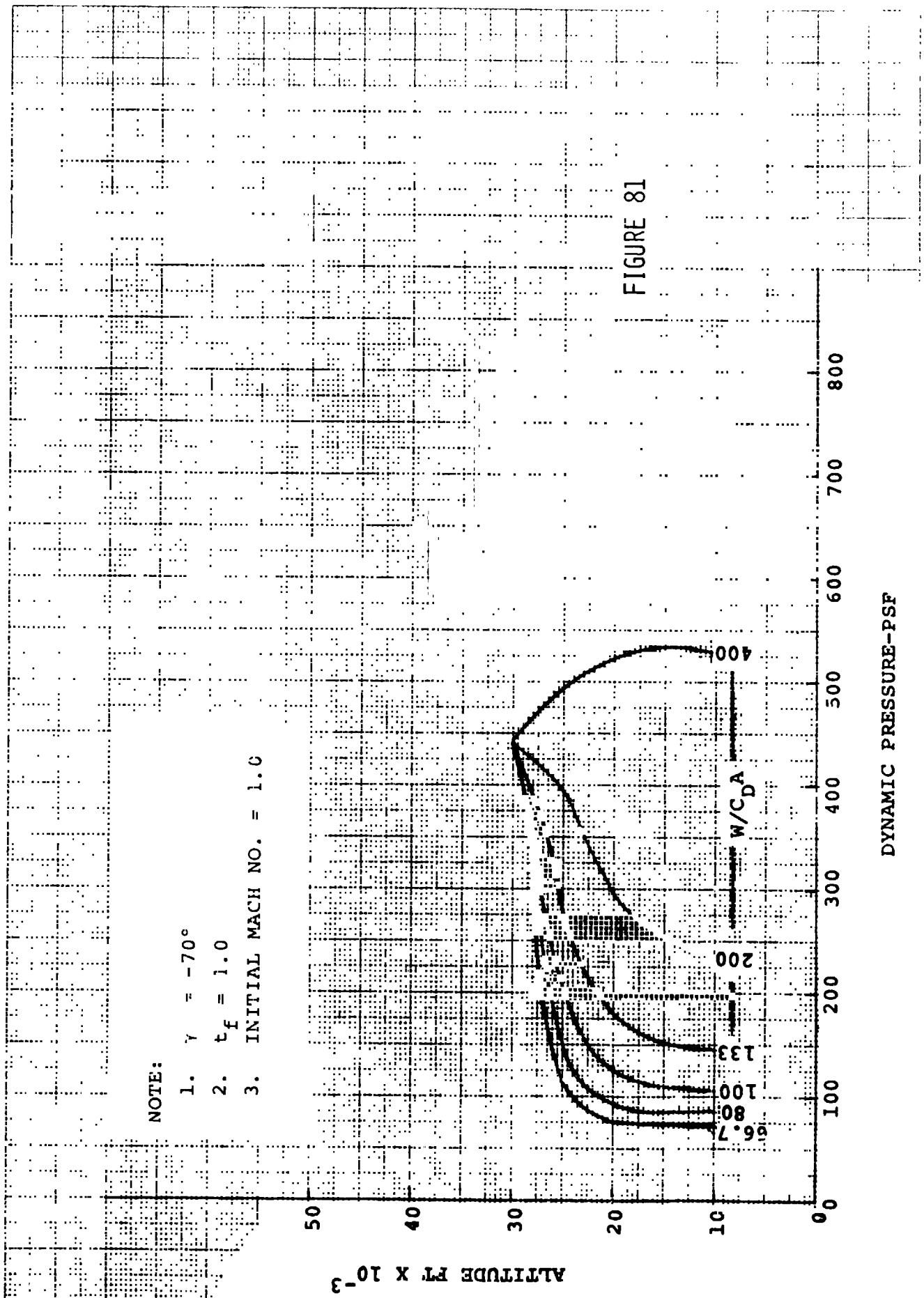

FIGURE 80



NOTE:

1. $\gamma = -70^\circ$
2. $t_f = 1.0$
3. INITIAL MACH NO. = 1.0

FIGURE 81

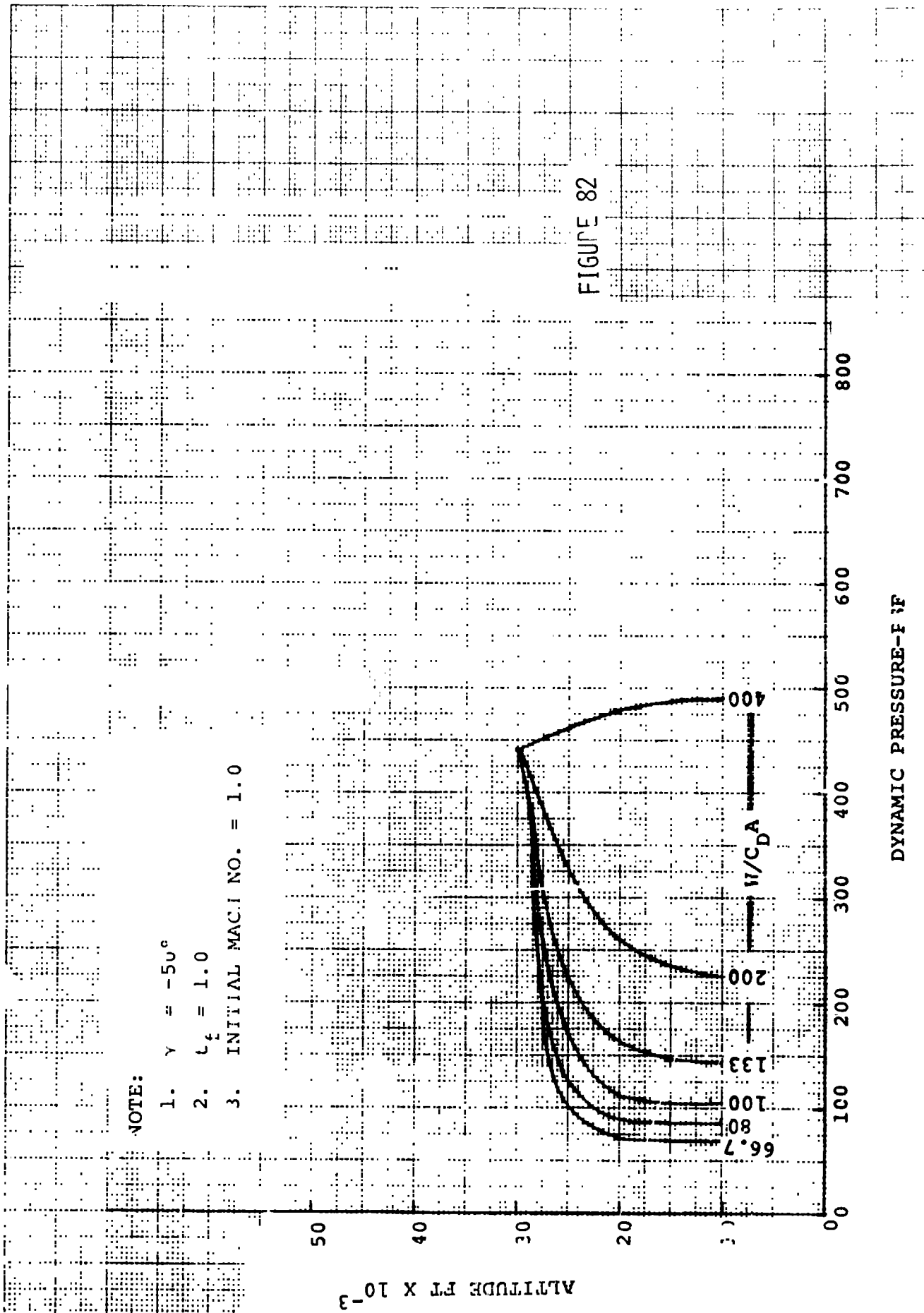

NOTE:

1. $\gamma = -50^\circ$
2. $L_4 = 1.0$
3. INITIAL MACI NO. = 1.0

FIGURE 82

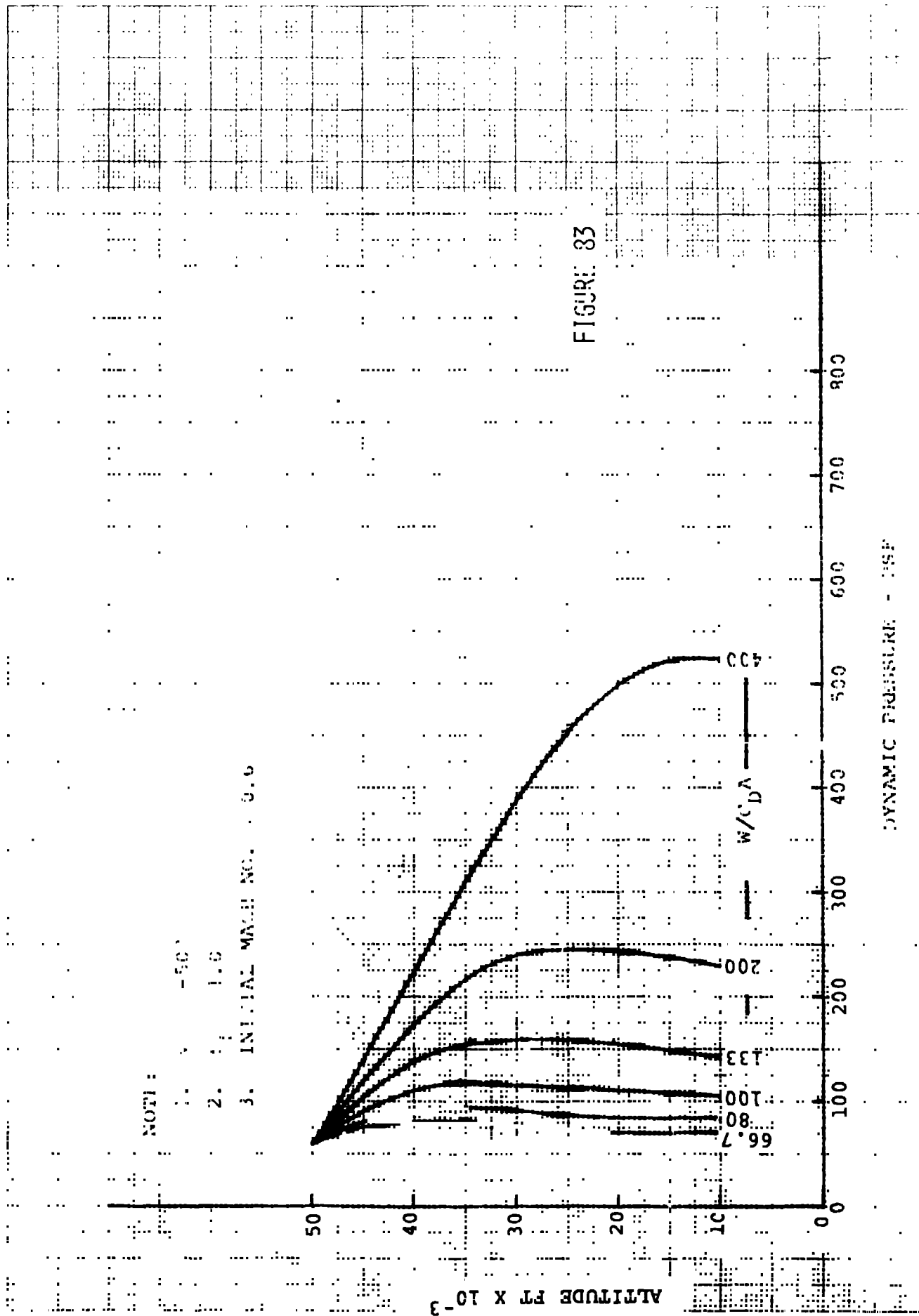

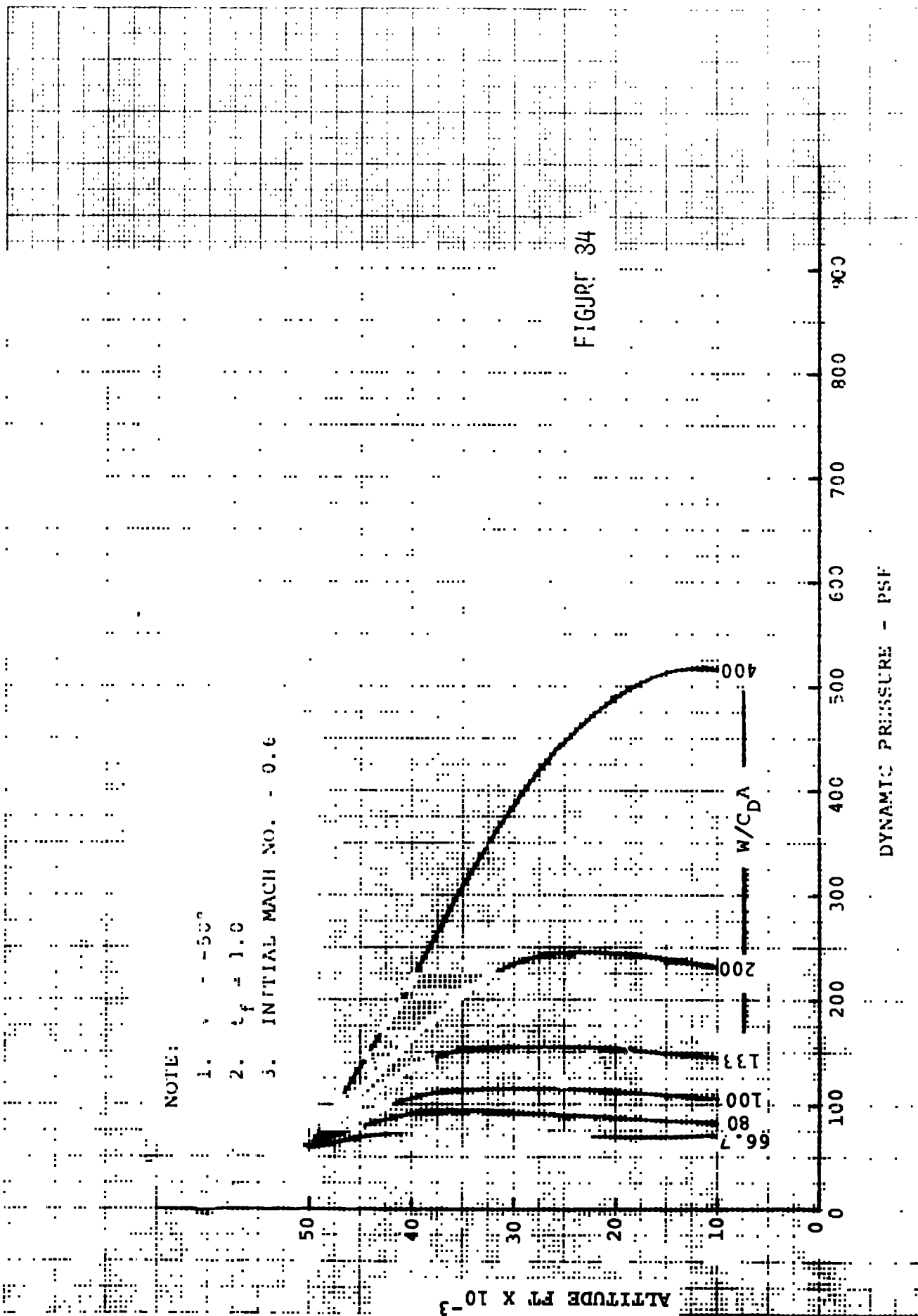

FIGURE 34

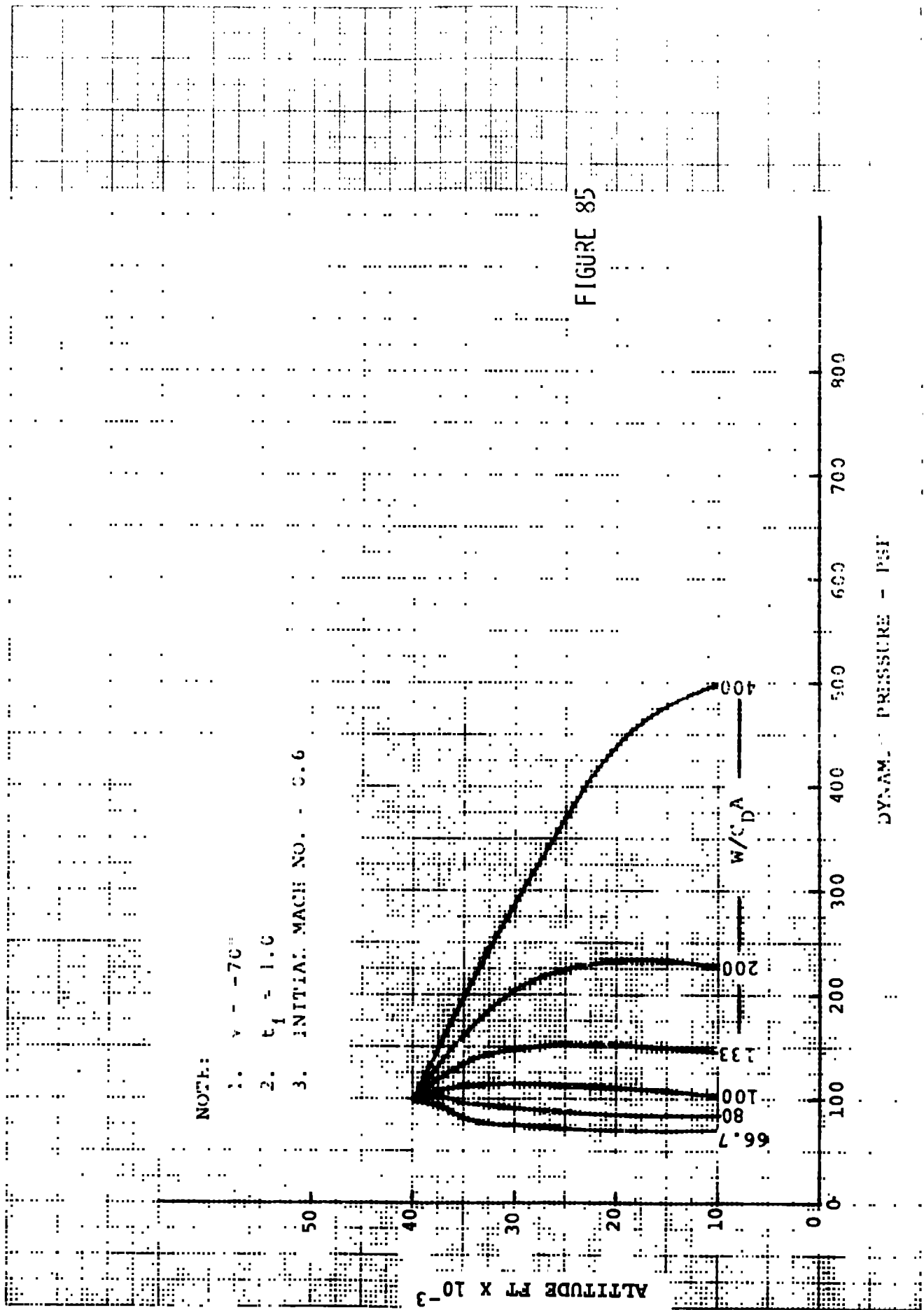

FIGURE 85

NOTE:

1. $\gamma = -10^\circ$
2. $t_c = 1.0$
3. INITIAL MACH NO. = 0.6

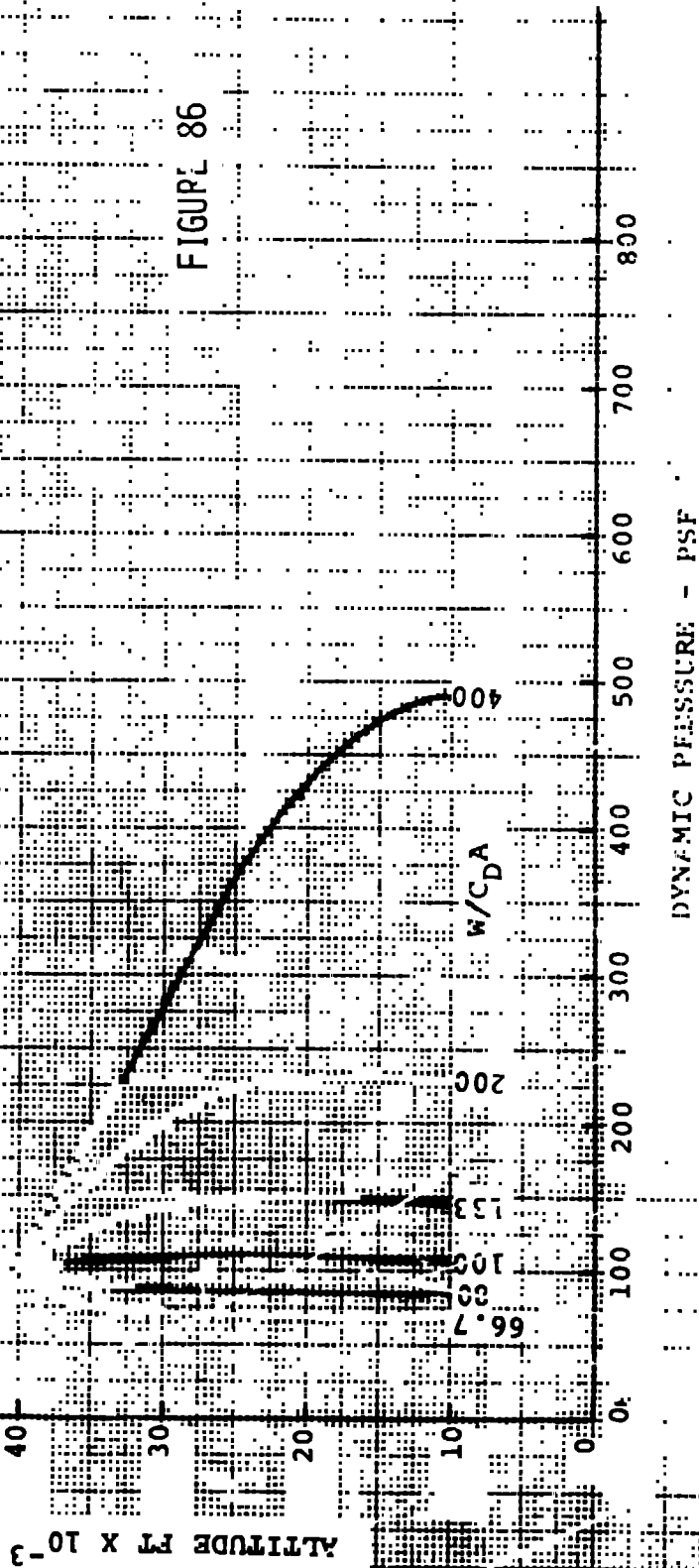

FIGURE 86

NOTE:

1. $\gamma = -70^\circ$
2. $\rho_f = 1.0$
3. INITIAL MACH NO. = 0.6

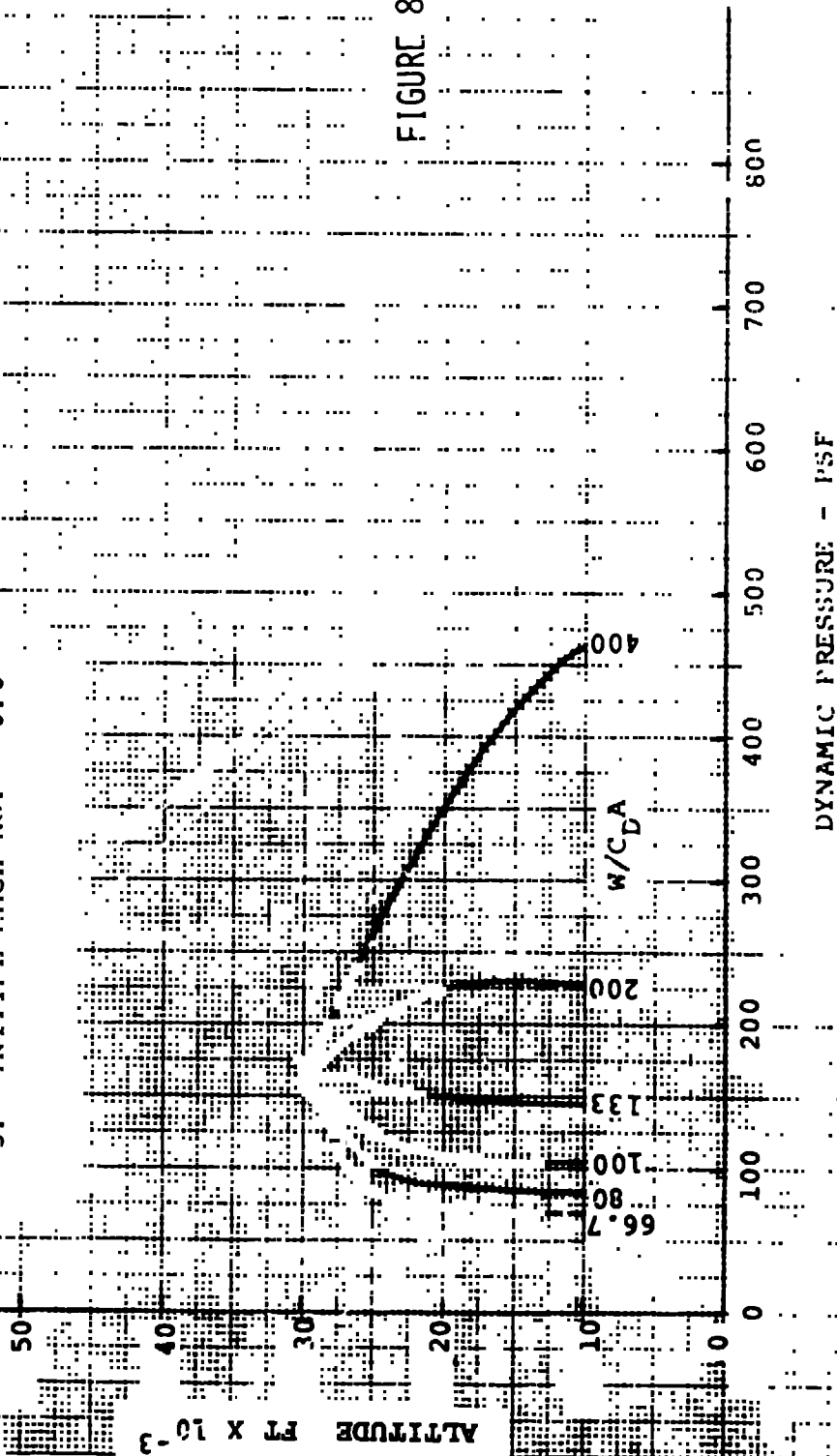

FIGURE 87

NOTE:

- 1. $\gamma = -50^\circ$
- 2. $L_f = 1.0$
- 3. INITIAL MACH NO. = 0.6

ALTITUDE FT X 10⁻⁴

50
40
30
20
10
0

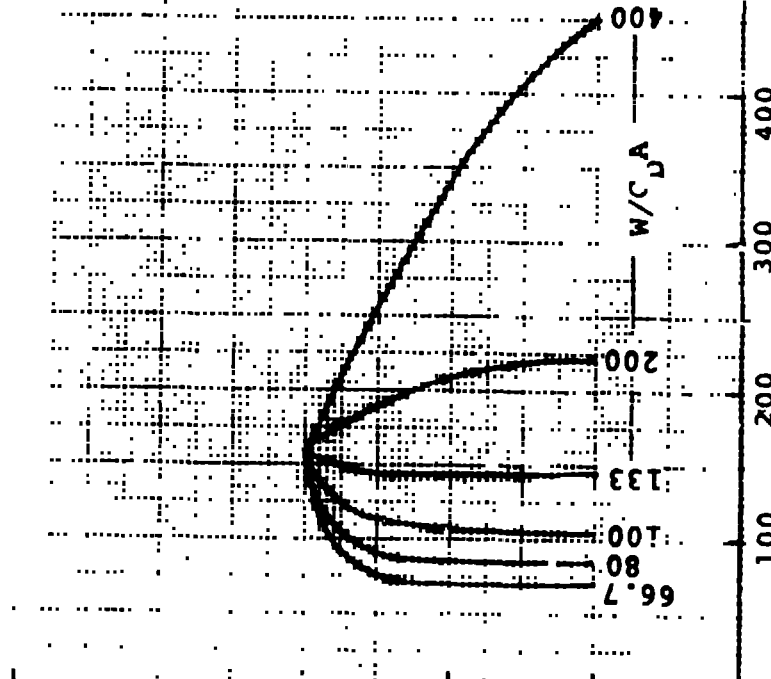

DYNAMIC PRESSURE-PSF

800

700

600

500

400

300

200

100

0

W/C_DA

400

200

133

100

80

66.7

FIGURE 88

- L_S/D_0 = ratio of parachute line length to parachute nominal diameter = 2.0
- C_{P_0}/C_{D_0} = ratio of local (maximum) canopy pressure coefficient to nominal drag coefficient = 3.5 at supersonic deployment
- A/S_0 = ratio of cloth area in canopy to nominal area = .85
- K_L = strength to weight ratio for suspension line material
= 1.73×10^9 ft. for nylon
- K_C = strength to weight ratio for canopy material = 8.72×10^4 ft for nylon

After substituting these values into Equation (6) the weight of the parachute is:

$$W_P = 4.90 \times 10^{-5} (D_0) (G's) (W) \quad (22)$$

As previously stated, this equation has been developed at GAC for parametric analysis purposes and holds true when optimum gauge materials are considered. For cases when a minimum gauge is applicable a component weight analysis would be required. Because of the relative complexity of this type of analysis and the fact that the parachute weight has a minimal affect on the deceleration loads, it is reasonable to use Equation 22 for purposes here.

TETHER WEIGHT

For the cases where a tether is required, its weight can be obtained from:

$$W_T = (D. F.) (W) (G's) \frac{L_T}{K} \quad (23)$$

where

D. F. = Design factor = 2.5

K = Strength to weight ratio for tether material
(nylon; 1.73×10^9 ft)

L_T = Tether length; m (ft)

The tether length is dictated by the same criteria as that for the main parachute.

where

$$L_T = (6.5) (D_{SRB}) - (L_S) \quad (24)$$

$$L_T = (6.5) (D_{SRB}) - (2) (D_0) \quad (25)$$

When the diameter of the SRB equals 142 inches, no tether will be required when the drogue diameter is greater than 38.4 feet.

BRIDLE WEIGHT

As previously mentioned, because of a variety of considerations which must be considered in establishing bridle requirements which are presently not known to GAC, this subject will not be analyzed herein. The only comment which would be applicable is that a preliminary estimate for bridle weight could be obtained from Equation 8 when the individual lengths of each leg are known, and an estimate for the design load $[(W)(G's)]$ can be made. In the event that a particular material gauge is selected then the weight could be calculated based on its weight per unit length.

5. Example Problem

To best present the use of the preceding data, an example problem will be presented so that each of the steps can be followed. The conditions which will be used for sizing are those previously determined for main parachute deployment of altitude equals 10,000 feet, and $q = 203$ PSF and a velocity of 481 ft/sec. An estimate for drogue size can be obtained from Figure 41 when the total system weight is known for Equation (21). From the previous example the $W_{SRB} + W_P + W_T$ equals 174,163 lbs. This will be the suspended weight on the drogue. An estimate for the drogue weight can be obtained from Figure 89 as a percent of W_{SRB} . When V_T equals 80 ft/sec for the mains, and if we assume drogue SRB deployment at $M = 1.4$ at 50,000 feet which corresponds to a q of 335 PSF the approximate deceleration force would be $335/203 = 1.65$, the W_D would equal approximately .01 or $W_D = (.01)(170,000) = 1700$ lbs. The total descent weight would become $174,163 + 1700 = 175,863$ lbs. From Figure 41 the estimated drogue drag area would be approximately 1000 ft² which would be equivalent to a D_0 of 50.5 feet from Figure 42. The filling time ratio from Figure 16 would be .0165 and t_f will be $(.0165)(50.5) = .84$ seconds.

To check if this size is correct go to Figure 44 and for a $q = 203$ PSF, the $W/C_D A = 172.5$ PSF. This would correspond to $C_D A = 175,863/172.5 = 1020$ ft² which is nearly identical to the 1000 ft² obtained from Figure A1.

The final determination of correct sizing can only be accomplished after the computer run is made and the end point computed. Any appropriate increase or decrease in size can be determined at that time.

Since the parachute size is greater than 38.4 feet D_0 , no tether is required. Although none is required for performance considerations, it will be assumed that for interface purposes a 15 feet long tether is desirable. The tether weight, from Equation 23 would be

$$W_T = \frac{(2.5)(175,863)(15)}{1.73 \times 10^5} = 38 \text{ lbs.}$$

The actual parachute weight would be, using Equation (22)

$$W_P = (4.90 \times 10^{-5})(50.5)(1.65)(175,863)$$

$$W_P = 730 \text{ lbs.}$$

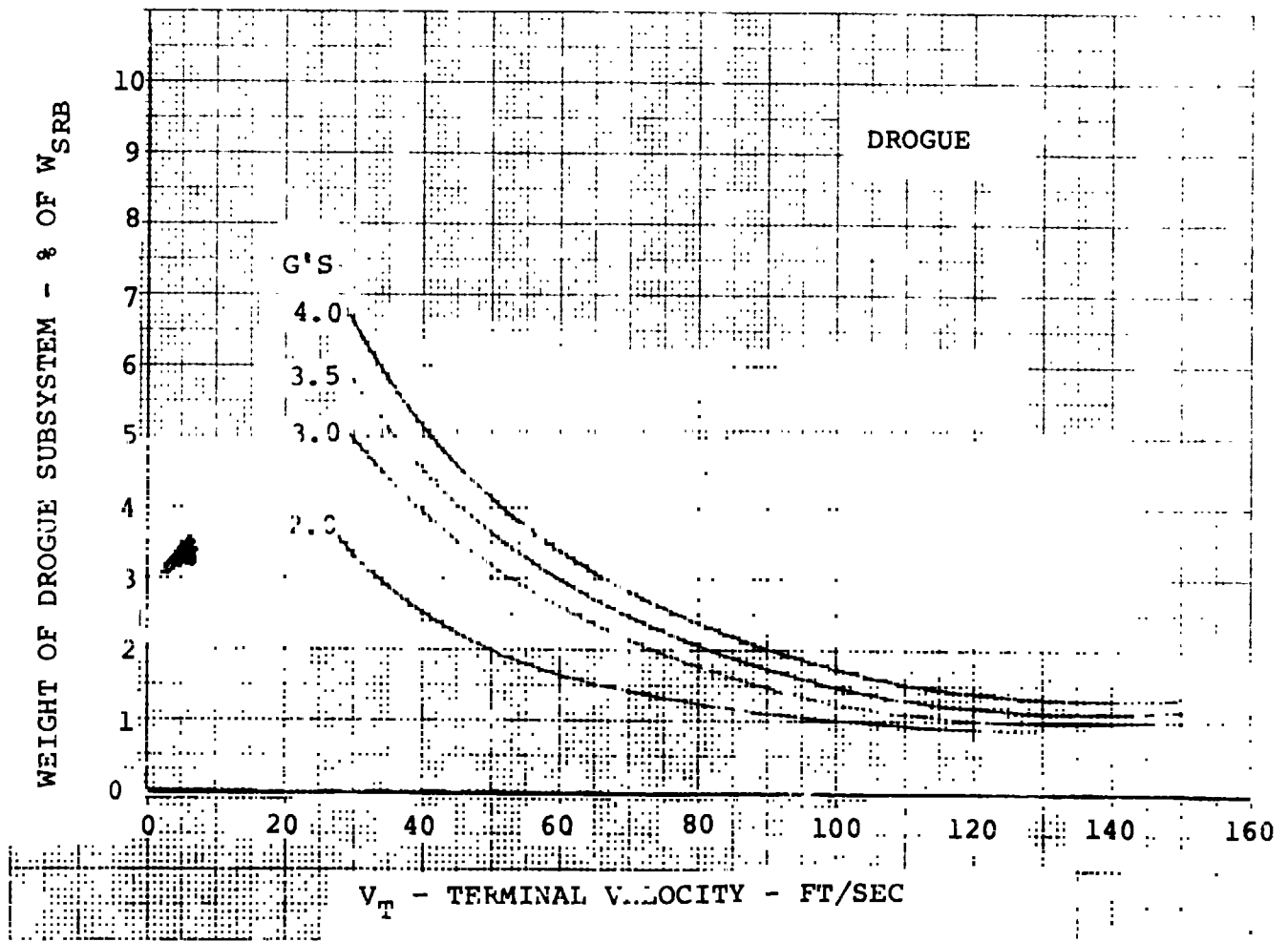

FIGURE 89 - RELATIVE WEIGHT OF DROGUE SUBSYSTEM VERSUS TERMINAL VELOCITY ON MAIN PARACHUTES

A second iteration could be made using these values for tether and drogue weight. This iteration will not be discussed here but with reference back to the main parachutes, only a slight change in diameter would result (estimated here to be .5 feet) and its affect would be minimal. Obviously, as many iterations as desired are possible, but it must be stated that the results of the computer run will show whether the selection was correct. Therefore, only two or three iterations are recommended and with the computer run results being the driver in subsequent iterations.

For other cases when the drogue deployment conditions could be at lower altitudes and lesser Mach numbers, (and longer inflation times) the appropriate figure can be chosen and W/C_{DA} selected. At the time of drogue deployment, the flight path angle will be something less than -90 degrees (probably -50 to -70 degrees). These affects can be realized from the Figures 71 thru 88.

Although drogue reefing is not desired, if required, the appropriate C_{DA} limit can be established by methods outlined for the main parachutes. The only item which cannot be readily defined from data herein would be the reefing time. This being the case, the particular stage can be run for an assumed amount of excess time, and the desired condition for the disreef function selected at the appropriate conditions. The inflation of the next stage would then begin at those conditions and a run continuation made. The results could then be pieced together to obtain the solution for the complete deceleration phase.

In summation, the drogue portion of the problem would have the following characteristics

$$W = 174,893 \text{ (lbs)}$$

$$W_{SRB} = 174,163 \text{ (lbs)}$$

$$D_0 = 50.5 \text{ (ft)}$$

$$W_P = 730 \text{ (lbs)}$$

$$L_T = 15 \text{ (ft)}$$

$$W_T = 38 \text{ (lbs)}$$

$$\text{Deploy Altitude} = 50,000 \text{ feet}$$

$$\text{Deploy Velocity} = \text{Mach No.} = 1.4$$

$$t_f = 0.84 \text{ seconds}$$

SECTION III

SUPPLEMENTARY PARACHUTE CHARACTERISTICS

A. General

In addition to the basic definition of the various parachute decelerators, additional characteristics of the parachutes must be defined. They include the mass properties, definition of the spring characteristics of the suspension lines, riser and tethers, definition of the aerodynamic coefficient, and a definition of the inflation characteristics. The following subsections will describe the method for determining each of these.

B. Mass Properties

The mass properties of the parachute include a definition of the center of gravity location, and the moments of inertia. Since the computer model analyzes the system motion in a single plane, only the pitch moment of inertia must be determined.

CENTER OF GRAVITY

The C_G of the parachute system is determined using conventional analysis methods. A parachute can be approximated as being a hemispherical shell for the canopy, and an inverted conical shell for the suspension lines or

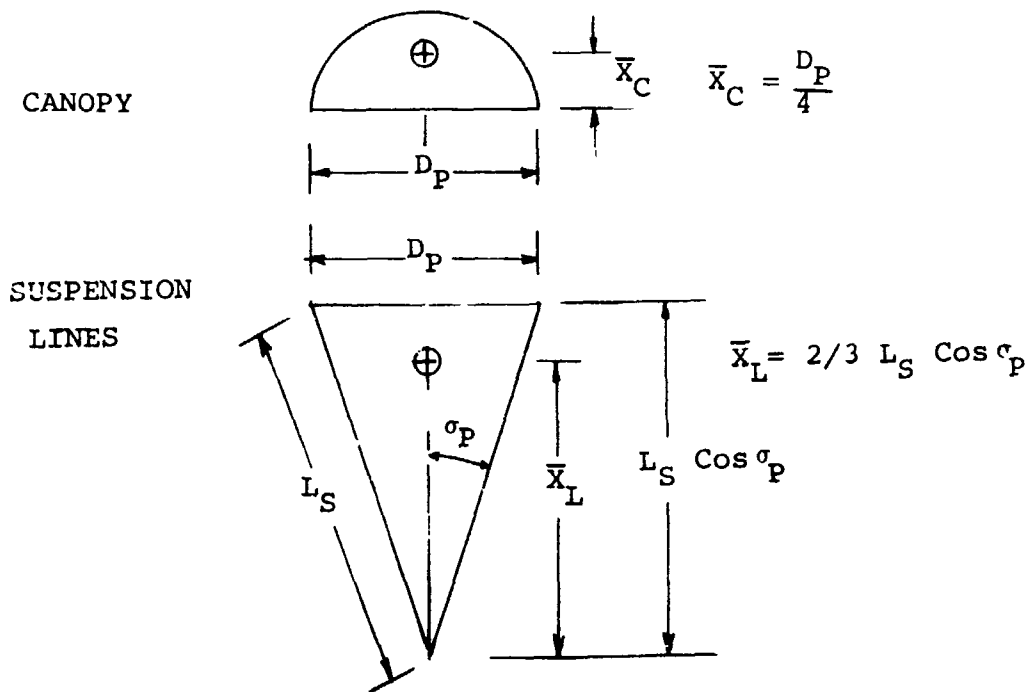

FIGURE 89A - PARACHUTE COMPONENT CG REFERENCE

when the two are combined together to form a parachute, the composite C_G is defined as

$$\bar{X}_P = \frac{(L_S)(\cos \bar{\gamma}_P)(2/3M_L + M_C) + (.165)(M_C)(D_0)}{M_L + M_C} \quad (25A)$$

where:

L_S = suspension line length, m(ft)

$\bar{\gamma}_P$ = half angle of suspension lines intersection; when $L_S = 1.5D_0$
 $\bar{\gamma}_P = 12.7$ degrees; when $L_S = 2.0 D_0$

$\bar{\gamma}_P = 9.5$ degrees

M_C = mass of parachute canopy and equals 32 percent of total mass for mains; and 33 percent of total mass for drogue

M_L = mass of suspension lines and equals 68 percent of total mass for mains, and 62 percent of total mass for drogue.

for these values, \bar{X}_P reduces to Equations 26 and 27 for a single main parachute and a drogue respectively

single Main $\bar{X}_P = 1.183 D_0 \quad (26)$

Drogue $\bar{X}_P = 1.631 D_0 \quad (27)$

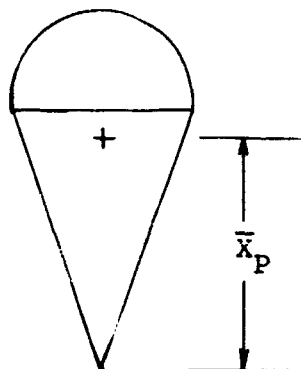

FIGURE 89B - PARACHUTE COMPOSITE CG REFERENCE

When a riser is included, Equation 28 is formed

$$\text{single Main + riser } \bar{X}_{P+R} = \frac{M_P(L_R + 1.183 D_0) + 1/2 (M_R)(L_R)}{M_P + M_R} \quad (28)$$

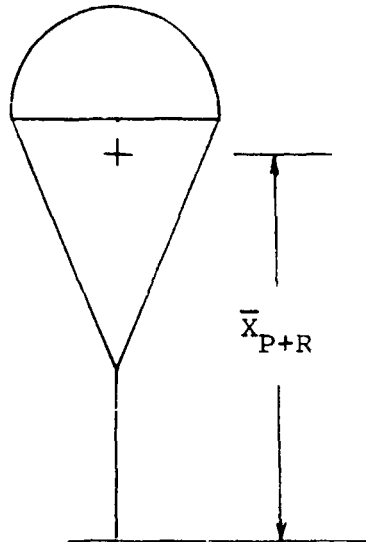
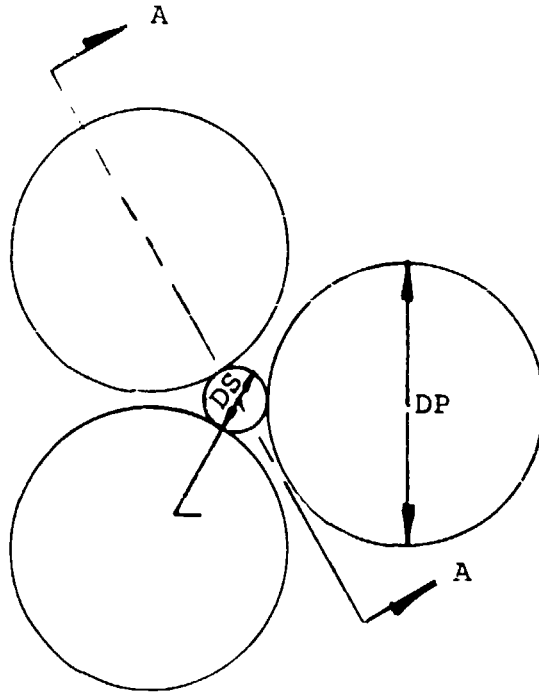

FIGURE 89C - PARACHUTE AND RISER COMPOSITE CG REFERENCE

When a cluster of parachutes is being considered, the C_G for the composite is determined as follows. A typical geometry representation is shown in Figure 90 for a cluster of three parachutes. When a riser is used Equation 30 is applicable and when no riser is required Equation 31 can be used.

$$\bar{X} = \bar{X}_{P+R} (\cos \sim) \quad (30)$$

$$\bar{X} = \bar{X}_P (\cos \tau) \quad (31)$$



☐ OF CLUSTER

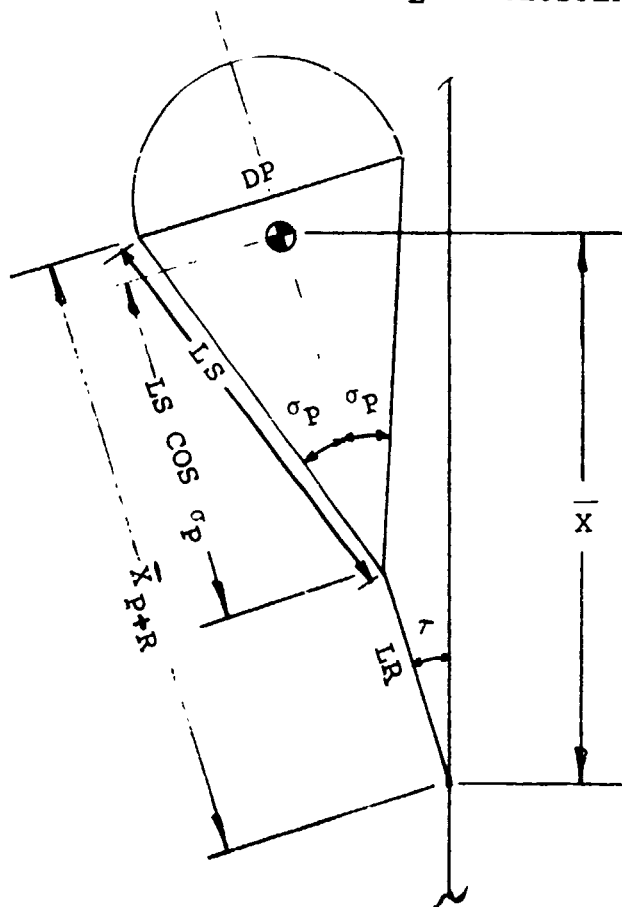

SECTION A-A

FIGURE 90 - TYPICAL GEOMETRY OF A 3 PARACHUTE CLUSTER

where τ = half angle at the intersection of the parachutes or risers.

This angle varies with the number of parachutes in the cluster. Initial estimates for τ can be found in Table IV

TABLE IV

Cluster Confluence Half Angle

N	τ (degrees)
3	22
4	24
5	26
6	28
7	30
8	32
9	34

MOMENT OF INERTIA

The pitch moments of inertia of the parachutes is derived using similar methodology as that for C_G determination.

When the canopy and cone formed by the suspension lines are assumed to be thin shells

$$\text{Canopy} \quad I_{OC} = \frac{5}{48} M_C D_P^2 \quad (32)$$

$$\text{Lines} \quad I_{OL} = \frac{M_L}{4} \left(\frac{D_P^2}{4} + \frac{2}{9} L_S^2 \cos^2 \tau_P \right) \quad (33)$$

$$\text{Riser} \quad I_{OR} = \frac{M_R L_R^2}{12} \quad (34)$$

For the total parachute, the moment of inertia is

$$I_{OP} = M_L (\bar{X}_L)^2 + M_C (L_S \cos \tau_P + \bar{X}_C)^2 + I_{OC} + I_{OL} - (M_C + M_L) (\bar{X}_P)^2 \quad (35)$$

and when a riser or tether is included

$$I_{OP+R} = M_R \bar{X}_R^2 + M_L (L_R + \bar{X}_L)^2 + M_C (L_R + L_S \cos \tau_P + \bar{X}_C)^2 + I_{OR} + I_{OL} + I_{OC} - (M_R + M_L + M_C) (\bar{X}_{P+R})^2 \quad (36)$$

When a cluster of parachutes is being used without a riser, the moment of inertia becomes

$$I_O = [1.5(M_C + M_L)(\bar{x}_P)^2 \sin^2 \tau] + 3 I_{O_P} \quad (37)$$

and when a riser is required, the moment of inertia is

$$I_O = [1.5(M_C + M_L + M_R)(\bar{x}_{P+R})^2 \sin^2 \tau] + 3 I_{O_{P+R}} \quad (38)$$

For all the above equations, the I_O is the moment of inertia about the center of gravity.

If the number of parachutes exceeds three, classical methods for calculating the moment of inertia are applicable.

C. Spring Characteristics

The loads which are imparted to the SRB resulting from the inflating parachutes are dependent upon the characteristics of the spring system through which the loading is transferred. The spring system is comprised of the parachute suspension lines, riser (if used), tether, if used, and the legs of the bridle. The analysis which follows concerns itself with all the components except the bridle. The derivation of K for the bridle legs will be left to the user of this manual. Each leg is read in as a separate spring.

Although a parachute's suspension system is comprised of a relatively large number of individual suspension lines, the computer model combines the system and utilizes only two springs. This is reflected in Figure 91.

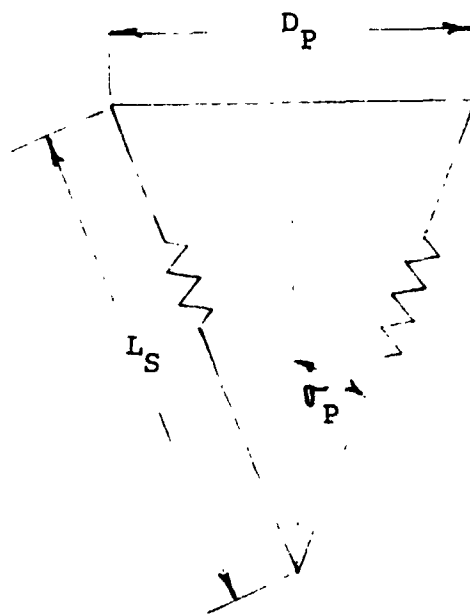

Figure 91. Computer Model Spring System

In general, for the total parachute

$$K_P = n \left(\frac{AE}{L_S} \right) \cos^2 \gamma_P \quad (39)$$

where: n = number of suspension lines

$$\left(\frac{AE}{L_S} \right) = \text{Spring constant of an individual suspension line}$$

AE = Material stiffness

For nylon; a typical value for AE is 3.8 times the ultimate strength of the material F_U . (This assumes maximum design loading occurs at 40% of ultimate.) In Equation 39, nAE will equal the total AE for all the suspension lines, and also will equal $(3.8)(F_U)$. Equation 39 becomes

$$K_P = \frac{3.8 F_U}{L_S} \cos^2 \gamma_P \quad (40)$$

when substitution is made for nAE .

For a single parachute $F_U = 2.5 F_D = (2.5)(G's)(W)$.

Substituting this into Equation 40 gives

$$K_P = 9.5 \frac{(G's)(W)}{L_S} (\cos^2 \gamma_P) \quad (41)$$

When a cluster of parachutes is considered, F_U for a single parachute would be $F_U = \frac{(1.5)(G's)(W)(2.5)}{N}$

and K_P would be

$$K_P = \frac{14.25 (G's)(W)}{N(L_S)} (\cos^2 \gamma_P) \quad (42)$$

The spring constant for a riser would be:

$$K_R = \frac{AE}{L_R} \quad (43)$$

similarly for the parachutes, if the riser material is nylon $AE = 3.8 F_U$ substituting into Equation 43, K_R becomes

$$K_R = \frac{3.8 F_U}{L_R} \quad (44)$$

where: F_U = the ultimate load capability of the riser = $2.5 F_{\text{Design}}$

When a cluster of parachutes is considered, each parachute will have its own riser. F_U for each riser will be the same as that for one parachute in the cluster. Substituting into Equation (44) gives

$$K_R = \frac{14.25 (G's)(W)}{N(L_R)} \quad (45)$$

For a tether the spring constant is

$$K_T = \frac{AE}{L_T} \quad (46)$$

and for nylon $AE = 3.8 F_U$, substituting into Equation 46 gives

$$K_T = \frac{3.8 F_U}{L_T} = \frac{9.5 (G's)(W)}{L_T} \quad (47)$$

If a cluster of parachutes is being considered, then a composite spring constant for the entire system of the parachute, riser, and tether must be calculated. The actual value which will be read into the program KKS is equal to one half of that for the total system. Referring to Figure 91, K for the parachute and riser is

$$\frac{1}{K_{P+R}} = \frac{1}{K_P} + \frac{1}{K_R} \quad (48)$$

and when the parachute cluster is considered, the K value is

$$K_{PC} = (N)(K_{P+R})(\cos^2 \tau) \quad (49)$$

and if a tether is included

$$\frac{1}{K_{PC+T}} = \frac{1}{K_{PC}} + \frac{1}{K_T} \quad (50)$$

The value KKS to be read into the computer program is equal to one half of the value computed for the composite system. These equations are general and can be used for any number of parachutes (N) in a cluster.

When used in the program, KKS of the two springs are connected at the confluence end and separated at the top end by a distance DLP (as defined in the fortran manual. For a single parachute DLP is equal to D_p of the parachute. For a cluster of parachutes without a riser:

$$DLP = 2 (L_S)(\cos \tau_p)(\sin \tau) \quad (51)$$

and when a riser is included

$$DLP = 2 (L_S \cos \tau_p + L_R)(\sin \tau) \quad (52)$$

The length of the springs are defined for the computer program as LS1 when a single parachute is used.

$$LS1 = L_S \quad (53)$$

and when a cluster is considered without a riser LS1 is:

$$LS1 = L_S \cos \nabla_P \quad (54)$$

If a riser is included, LS1 becomes

$$LS1 = L_S \cos \nabla_P + L_R \quad (55)$$

Depending on the particular configuration being considered, the appropriate forms of the preceding equations can be selected.

D. Aerodynamic Characteristics

The computer program requires as input data, values of four aerodynamic coefficients which are related to the parachute system. These four sets of coefficients are:

1. axial coefficient, CCAP (C_{D_0})
2. moment coefficient, CCMP (C_M)
3. normal force coefficient, CCNP (C_N)
4. damping moment coefficient CCMQP (C_{MQ})

Each of these values is read in the program as an array 16 columns wide, and 8 rows long. The columns represent the values at various angles of attack and the rows represent MACH number. The particular MACH number associated with each column and particular angle of attack represented by each row are specified by a read-in function. A straight line or linear interpolation is used to obtain values between those tabulated.

A limited amount of data exists for these coefficients for clusters of parachutes. The primary amount can be found in Report Number ASD-TDR-63-159; Wind Tunnel Study Of Parachute Clustering by J. F. Braun (AD Number 40277). This report documents the results of wind tunnel testing of four parachute types with from one to seven parachutes being tested in a cluster. The parachute types investigated were, (1) flat circular, (2) extended skirt, (3) ring slot, and (4) ribbon. The data that was obtained from these tests was for the composite system, or what could be referred to as an equivalent. Typical values for the coefficients of axial coefficient, and moment coefficient for the ring slot and ribbon parachute are shown in Tables V and V-A. As can be seen from the table, clusters of 1, 2, 3 and 5 parachutes were considered with various parachute reefing ratios, and riser lengths. Data for the other configurations can be found in the referenced report. In addition, aerodynamic performance

TABLE V

Aerodynamics Of Ring Slot Parachutes In A Cluster

Ref. Wind Tunnel Study of Parachute Clustering
J. F. Braun April 1963
AD 402777
ASD TDR 63-159

	No. In Cluster	Reef'g Ratio	Riser Length	Pg. No.	Fig No.	CA (CD ₀)	C _M					
							α ~ Degree					
							0	2.5°	5.0°	7.5°	10.0°	15.0°
Tangential (C _A) And Moment (C _M) Coefficients	1	0.0	0 D ₀	50	77	.48	0.0	.012	.010	-.010	-.057	
	1	.5	0 D ₀	51	78	.35	0.0	-.05	-.10			
	1	.3	0 D ₀	51	79	.13	0.0	-.025	-.04			
	1	.2	0 D ₀	52	80	.05	0.0	-.013	-.033			
	2	0.0	.5 D ₀	52	81	.46	0.0	-.05	-.083			
	3	0.0	1.0 D ₀	53	82	.46	0.0	-.037	-.087			
	3	0.3	.5 D ₀	53	83	.46	0.0	-.035				
	3	.5	1.0 D _c	54	84	.37	0.0	-.07	-.15			
	3	.5	.5 D ₀	54	85	.34	0.0	-.055				
	3	.3	1.0 D ₀	55	86	.24	0.0	-.027	-.075			
	3	.3	.5 D ₀	55	87	.22	0.0	-.023	-.075			
	5	0.0	1.5 D ₀	56	88	.45	0.0	-.055				
	5	0.0	1.0 D ₀	56	89	.44	0.0	-.033				

TABLE V-A

Aerodynamics Of Ribbon Parachutes In A Cluster

Ref. Wind Tunnel Study of Parachute Clustering
 J. F. Braun April 1963
 AD 402777
 ASD TDR 63-159

	No. In Cluster	Reef'g Ratio	Riser Length	Pg. No.	Fig No.	CA (C _{D0})	C _M					
							X Degrees					
							0	2.5°	5.0°	7.5°	10.0°	15.0°
Tangential (C _A) And Moment (C _M) Coefficients	1	none	0 D ₀	43	62	.51	0	.02	.03	.03	.019	-.055
	1	.5	0 D ₀	43	63	.36	0	-.025	-.031	-.05	-.067	-.10
	1	.3	0 D ₀	44	64	.14	0	-.031	-.053			
	1	.2	0 D ₀	44	65	.02	0	-.015	-.033			
	2	none	.5 D ₀	45	66	.5	0	-.004	-.008	-.013	-.018	
	2	.5	.5 D ₀	45	67	.37	0	-.027	-.075			
	3	none	1.0 D ₀	46	68	.50	0	-.025	-.055	-.11		
	3	none	.5 D ₀	46	69	.50	0	-.025	-.050			
	3	.5	1.0 D ₀	47	70	.38	0	-.05	-.11			
	3	.5	.5 D ₀	47	71	.53	0	-.05	-.09			
	5	none	1.5 D ₀	48	72	.48	0	-.025	-.063			
	5	none	1.0 D ₀	48	73	.47	0	-.025	-.05			
	5	none	.5 D ₀	49	74	.48	0	-.025	-.05			
	5	.5	1.5 D ₀	49	75	.40	0	-.04	-.11			
	5	.5	1.0 D ₀	50	76	.39	0	-.03	-.065			

data can be found in ASD-TR-61-579 - Performance of and Design Criteria for Deployable Aerodynamic Decelerators, for single parachutes. In addition a variety of other reference data can be found for single parachutes.

The data as shown in Table V is referenced to the D_0 of a single parachute in the cluster, and the total reference area of all the parachutes in the cluster. In other words, for parachutes which are other than full open (reefed) the coefficients are referenced to the full open diameters and areas.

Since the computer program is presently capable of handling only one set of coefficients (which would represent a particular stage of inflation) the greatest accuracy of load calculation can be obtained by making individual runs and inputting the proper reference dimensions for each. The reason that this problem exists is that the reference area of the parachute is read in as a function of time (described in the next subsection). Since the coefficients are not proportional to this size variation, the resulting need for making individual runs for each stage is applicable. It is not unrealistic though to make first pass approximations for the entire system on a single run to insure that proper inflation times and reefing times have been chosen.

The values which should be used for the axial coefficient are those which have been utilized in computing parachute sizes in Section II. For the main parachutes, the C_{DA} value would be equal to C_{D_0} times the pertinent cluster efficiency factor (η) and for the drogue C_{D_0} the basic nominal C_{D_0} is applicable.

The C_N , normal force coefficient is determined as follows. The moment about the confluence point of a cluster of parachutes is given by

$$M_0 = (-X_{CP})(F_N) \quad (56)$$

where X_{CP} = the distance from the confluence point of the parachute to the center of pressure, M (ft)

F_N = normal body force, N (lbs)

Conventional definitions of aerodynamic force and moment gives,

$$(C_M)(q)(S)(D_0) = (-X_{CP})(C_N)(q)(S) \quad (57)$$

$$(C_M)(D_0) = (-X_{CP})(C_N) \quad (58)$$

$$C_N = -C_M \frac{(D_0)}{X_{CP}} \quad (59)$$

where: C_N is the normal force coefficient
 C_M is the moment coefficient about Pt. 0.
 D_0 is the parachute nominal diameter.

The distance X_{C_P} is defined as,

$$X_{C_P} = (L_S \cos \tau_P + L_R) \cos \tau \quad (60)$$

where: L_S is the suspension line length
 L_R is the riser line length

It is assumed the center of pressure is located by the intersection of the parachute axis of symmetry and a plane passing through the leading edge of the canopy.

Values for C_N can be obtained from Equation 59 when C_M , D_0 , and X_{C_P} are known.

The damping coefficient C_{M_0} which should be used is equal to -0.1 and is an estimated value. Since no empirical data is available, this value has been assumed reasonable.

E. Inflation Characteristics

The inflation characteristics for the parachutes are primarily dealing with the area increase of the parachute as it inflates. The particular area change rate with filling time is shown in Figure 92 as an area ratio versus a filling time ratio. The A_{MAX} is equal to the area of all the parachutes in the cluster and the value for t_f is the filling time for the particular stage. A typical example of the use of this data will be made for the main parachutes selected in Section II.

From Table II, the first reefed stage was a D of 46.5 feet for one parachute and used an inflation time of 2.07 sec. For the 3, 46.5 feet diameter parachutes, the A_{MAX} would be 5100 ft². Table VI summarizes the data for various filling time ratios and gives the time and area at each increment.

TABLE VI

First Stage Inflation Characteristics

t/t_f	A/A_{MAX}	t (sec)	A (ft ²)
0	0	0	0
.2	.04	.40	220
.4	.16	.80	815
.6	.36	1.24	1835
.8	.64	1.66	3265
1.0	1.0	2.07	5100

The second stage would have a diameter of 80.4 feet per parachute or an A_{MAX} of 15,300 ft² and an inflation time of 2.92 sec. These characteristics are summarized in Table VII. For this case, since the system is starting partially

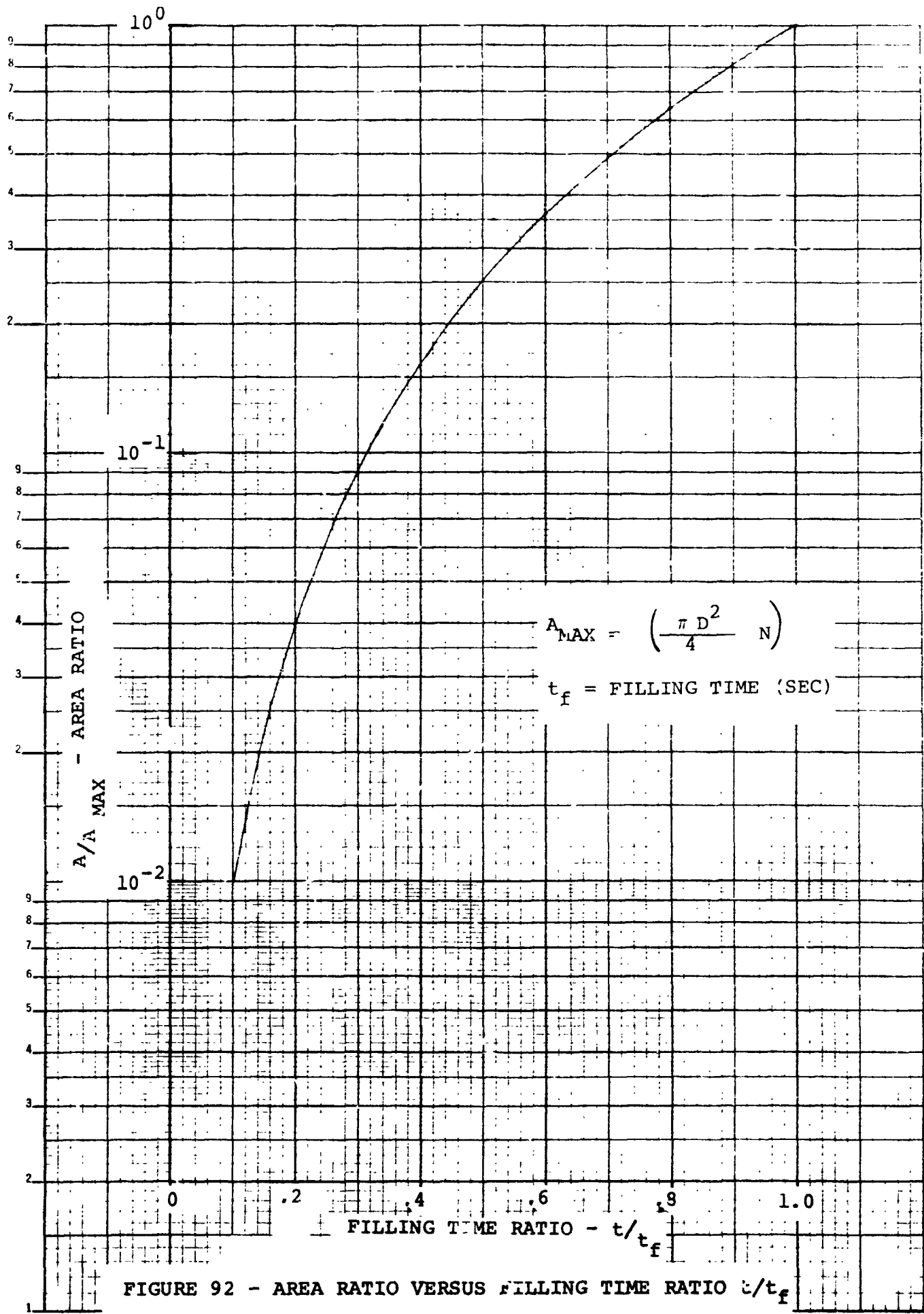

FIGURE 92 - AREA RATIO VERSUS FILLING TIME RATIO t/t_f

TABLE VII

First Stage Inflation Characteristics

t/t_f	A/A_{MAX}	t (sec)	A (ft ²)
0.0	0	0	5,100
0.2	.04	.58	5,508
0.4	.16	1.16	6,730
0.6	.36	1.75	8,770
0.8	.64	2.34	11,620
1.0	1.0	2.92	15,300

inflated, the applicable area A_{MAX} is the difference between the end of this stage and the end of the previous stage or $15,300 - 5100 = 10,200$

The full open stage which has a single parachute diameter of 139.6 feet and filling time of 8.25 seconds the A_{MAX} for this stage is 45,900 ft². Table VIII presents the characteristics for this stage.

TABLE VIII

Full Open Inflation Characteristics

t/t_f	A/A_{MAX}	t (sec)	A (ft ²)
0	0	0	15,300
0.2	.04	1.65	16,520
0.4	.16	3.30	20,200
0.6	.36	4.95	26,300
0.8	.64	6.60	34,900
1.0	1.0	8.25	45,900

The A_{MAX} which is used, is equal to $45,900 - 15,300 = 30,600$ ft²

The data from Tables VI, VII and VIII along with the reefing times from Table III are plotted in Figure 93 to show the inflation of the main parachutes on a single plot. Using Figure 93, the 16 element array of time and respective area can be obtained for input to the computer program.

Another factor that is associated with the parachute inflation is an additional mass which must be added to the system. This virtual or added mass accounts for the mass of air which is enclosed within the parachute, and also carried along as part of the wake. This mass can be inputted to the program in increments similar to the area input. Experience has shown that a reasonable estimate for this value is to assume the volume of a hemisphere that corresponds to the particular reference diameter at the respective inflation state and use the air density at the particular altitude

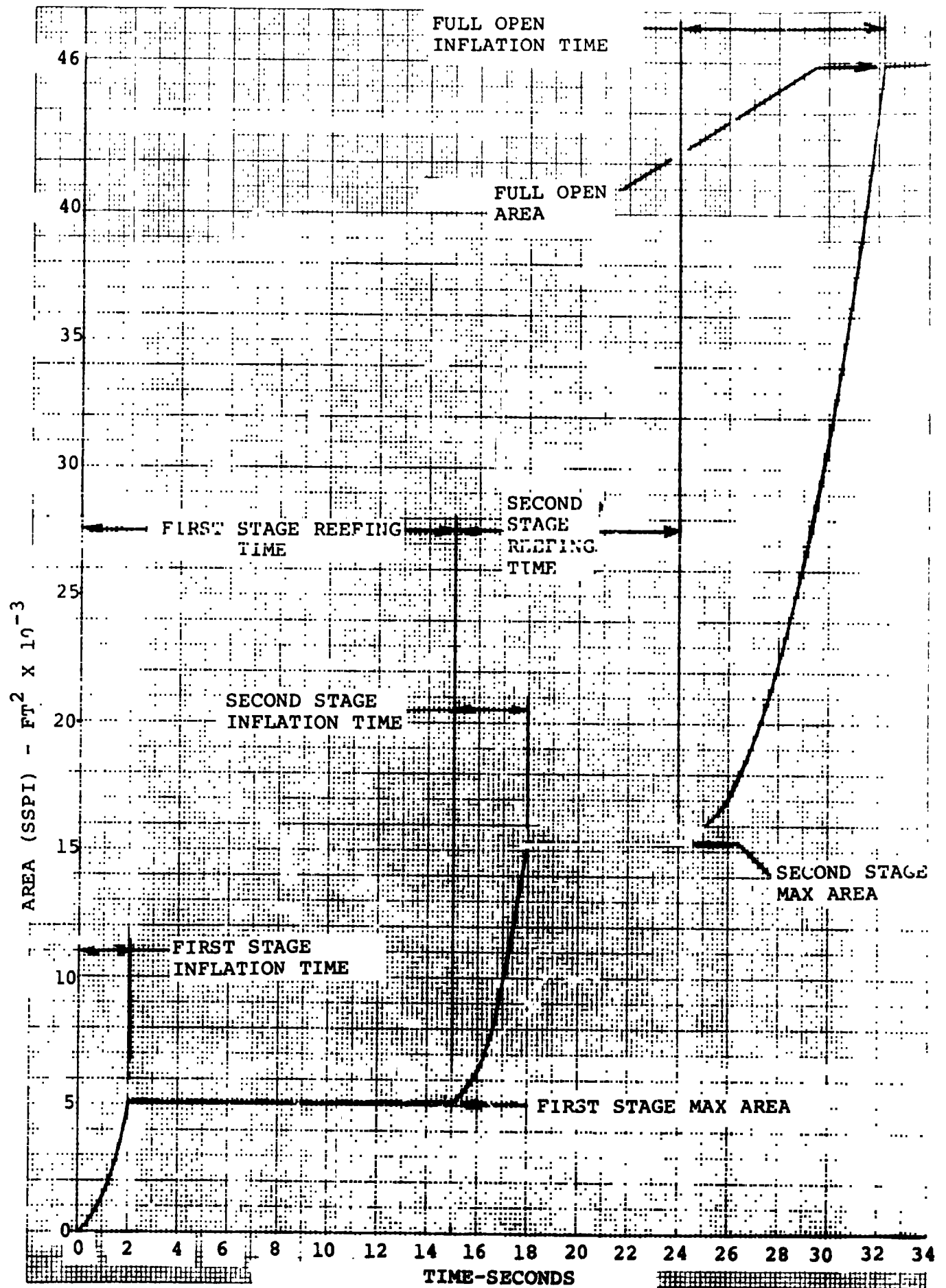
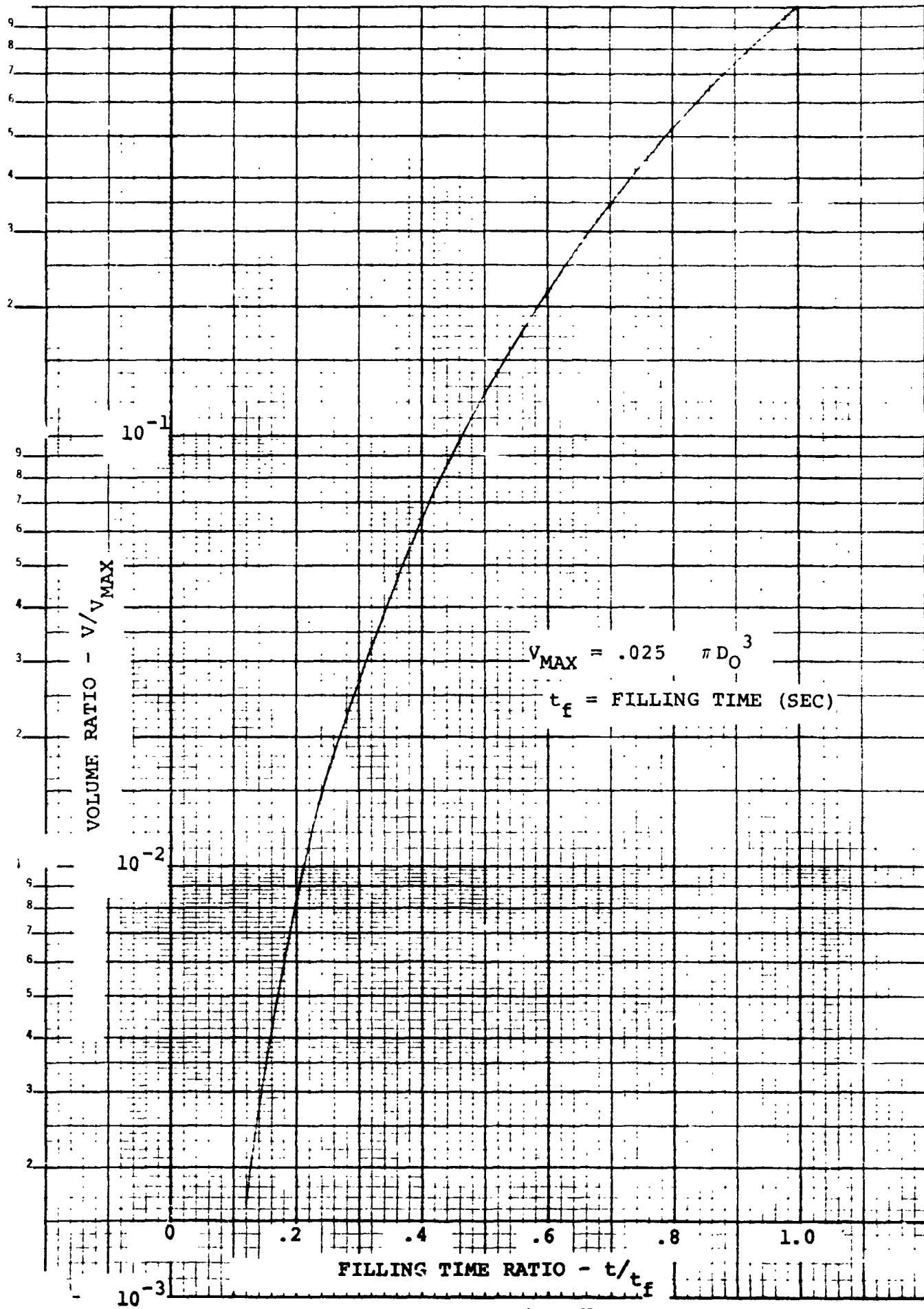

FIGURE 93 - MAIN PARACHUTE INFLATION TIME HISTORY

to compute the mass. Presented in Figure 94 is the volume ratio versus the filling time ratio and is very similar to Figure 92. The magnitude for V_{MAX} as reflected on the figure is that of a hemisphere and is referenced to the D_0 of the particular stage being considered. Using Figure 94 and the filling times of Table III the volume can be calculated and plotted similar to Figure 93. If the altitudes can be estimated at each of the steps, then the density at that altitude can be used to calculate the vertical air mass for the respective time. This mass function can also be plotted similar to Figure 93. The respective mass for each of the times chosen for the inflation read-in, can then be obtained directly from the mass figure which would be generated.

It is important to note here that the virtual air mass will affect the center of gravity and moment of inertia of the parachute system. It is recommended that this affect be taken into account when calculating the center of gravity and moments of inertia.



$V_{MAX} = .025 \pi D_0^3$
 $t_f = \text{FILLING TIME (SEC)}$

FIGURE 94 - VOLUME RATIO V/V_{MAX} VERSUS FILLING TIME RATIO t/t_f

SECTION IV

CONCLUSIONS AND RECOMMENDATIONS

A. Conclusions

The contents of this report have been prepared to provide the user of the computer program described in GER-15853 - USERS MANUAL - "Computer Program for the Load and Trajectory Analysis of Two 3 D. O. F. Bodies Connected By an Elastic Tether", with a method for establishing preliminary input data. This report provides data in the form of parachute, riser and tether sizes and weights; parachute deployment conditions, inflation times and reefing times. In addition, a method for computing the mass properties, spring characteristics, aerodynamic coefficients and inflation characteristics is also explained.

The manual is not intended to provide a complete design manual for the SRB parachute system but only to provide a definition of the primary components which contribute to the parachute system deceleration loads.

1. The primary conclusion which has been reached during the course of this contract's performance is that the use of this computer program should be limited primarily to the main parachute deceleration phase. This results because of the expected motion of the SRB at the time the drogue parachute would be deployed.

At the present time, it is anticipated that the SRB will either seek, or be forced into what is termed a maximum drag configuration. This means that depending on the configuration of the SRB, and its relative center of gravity and center of pressure location that it will re-enter and seek an angle of attack of approximately 95 degrees (or nearly broadside), and exhibit what could be termed a "wobbling" motion with resulting yaw pitch and roll velocities. The other extreme is to add devices to the exterior of the SRB called "strakes" which will influence the SRB aerodynamics in such a way as to force it in a near flat spin condition where the angle of attack would be somewhere between 95 and 105 degrees and the SRB would have considerably higher yawing and pitching velocities and exhibit a "coning" motion.

Because of these expected motion characteristics and the SRB motion which will result when the force of the drogue parachute is applied to it, that although adequate answers will be obtained, their accuracy would be questionable.

Since the purpose of the drogue is to stabilize and/or decelerate the SRB to conditions for main parachute deployment this problem will not exist during the main parachute deceleration phase.

2. In addition, as has been stated within the basic text of this report, only one set of aerodynamic coefficients for the parachute can be read into the program for a particular run being made. This means that although

the proper reference dimensions for various reefed stages are available within the program (because of their being read in) a slight error in calculated loads will result because the coefficients at the reefed stages relative to the full open parachute(s) are not directly proportional to their size.

B. Recommendations

1. Because of the expected motion of the SRB at the time of drogue deployment, it is recommended that a more exact representation of this phase of deceleration be obtained. The model which would represent this is similar in that there would be two bodies connected by an elastic tether. The difference from the model of this program is that there would be 6 degrees of freedom (6 D. O. F.) on the forebody (SRB) and 5 degrees of freedom on the aftbody (Parachute). The 6 degrees are three translational (X, Y, Z) and three rotational (yaw, pitch, roll). The component of roll is not considered for the parachute. This model would then more accurately describe the motion of the SRB during stabilization and establish the affects on the loads during this transition phase.
2. It is also recommended that when the loads for the reefed stages are to be evaluated in a final form, that each stage be analyzed with a single run and the appropriate aerodynamics coefficients for the particular stage be used. This then will provide the greatest accuracy in the computed results.