

P
2 mix

NASA CR-114594
Available to the Public

CHEMICAL PUMP STUDY

BY

Lyle E. Bergquist

June 1973

(NASA-CR-114594) - CHEMICAL PUMP STUDY	N73-25518
(Martin Marietta Corp.) 8T p HC \$6.25	
82 CSCL 13I	
	Unclas
	G3/15 06229

Prepared under Contract No. NAS2-7383

By

Martin Marietta Aerospace
Denver, Colorado 80201

for

Ames Research Center
National Aeronautics and Space Administration

CHEMICAL PUMP STUDY

BY

Lyle E. Bergquist

June 1973

Prepared under Contract No. NAS2-7383

By

Martin Marietta Aerospace
Denver, Colorado 80201

for

Ames Research Center
National Aeronautics and Space Administration

1. SUMMARY

This report describes work performed at the Denver Division of Martin Marietta Corporation on Contract No. NAS2-7383. The general topic of the study is an investigation of getter pumps applicable to the Pioneer Venus Mass Spectrometer Experiment. The work was divided into four subtasks: (1) a survey of existing getters, (2) a determination of pump requirements, (3) test of a particularly promising class of getter pump, and (4) Preliminary design of a pump. Three applications formed the basis for the study: (1) a noble gas experiment, (2) reduction of atmospheric pressure, and (3) maintenance of vacuum in a non-operating instrument.

Most promising among the getter materials surveyed, were zirconium aluminum and zirconium graphite products of SAES Getter S.P.A., Cer Alloy 400 a product of the Ronson Corporation and Synthetic Zeolites produced by the Linde Division of Union Carbide.

Mathematical models were developed to quantify the pump requirements for the three applications.

SAES zirconium aluminum pumps were laboratory tested under conditions pertinent to the enhancement of the noble gas components of the atmosphere for a noble gas analysis. This pump type proves to be well suited to the needs of a noble gas experiment and may also be found suitable to the other two applications.

Based on the mathematical model of the noble gas experiment and the tests of the zirconium aluminum getters, a preliminary design has been produced for a noble gas enhancement pump. This pump, mounted exterior to the probe, uses the hot Venus atmosphere to achieve its operating temperature. It requires no post launch power.

TABLE OF CONTENTS

	<u>Page</u>
1. SUMMARY	ii
TABLE OF CONTENTS	iii
2. LIST OF SYMBOLS	vi
3. INTRODUCTION	1
4. PUMP REQUIREMENTS	3
4.1 Noble Gas Experiment	3
4.2 Atmospheric Pressure Reduction System	10
4.3 Vacuum Maintenance	14
5. SORPTION PUMP SURVEY	18
5.1 Limitations	18
5.2 Discussion of Comparison Parameters	18
5.3 Getter Materials	20
5.4 Specifications and Comments of Getter Candidates	21
5.5 Conclusions and Recommendations	37
5.6 Follow-On Material Evaluation Studies	41
6. TESTING OF SAES ST-101 PUMPS	43
6.1 Method of Testing	43
6.2 Test Setup	45
6.3 Test Conditions	48
6.4 Results	50
7. PUMP DESIGN	59
7.1 Design Constraints	59
7.2 Design Configuration	64
7.3 Getter Heating	64
7.4 Model Fabrication and Test	67
References	72

LIST OF FIGURES

<u>Figure</u>		<u>Page</u>
4.1	Schematic of Noble Gas Inlet System	5
4.2	Schematic of Two-Stage Pressure Reduction System	11
5.1	Zirconium Aluminum Getter	24
5.2	Zirconium Graphite Getter	28
5.3	Carbon Dioxide Adsorption Characteristics in Several Adsorbing Materials	34
5.4	Adsorption Isotherms. Nitrogen on Molecular Sieve 5A	35
6.1	Schematic of Pump Speed Test	46
6.2	Test Chamber Profile	46
6.3	Experiment Test Configuration	47
6.4	Leak Calibration	49
6.5	Pump Capacity Test	54
6.6	Pump Capacity Test - Second Pump	56
6.7	Noble Gas Growth in Getter Pumped Volume	57
7.1	Processing Volume Pressures	63
7.2	Noble Gas Experiment Design	65
7.3	Network for Getter Temperature Analysis	66
7.4	Atmospheric Getter Heating	68

LIST OF TABLES

<u>Table</u>		<u>Page</u>
5.1	Gas Capacity for Zirconium Graphite	25
5.2	Pumping Speed for Zirconium Graphite	26
5.3	Capacity Cer Alloy 400	30
5.4	Pumping Speed for Cer Alloy 400	30
6.1	Fractional Abundances in Test Gas	48
6.2	Speed Measurements with First Pump (SAES ST-101, C-200)	51
6.3	Speed Measurements with Second Pump (Second Activation)	52

2 LIST OF SYMBOLS

<u>Symbol</u>	<u>Section</u>	<u>Use</u>
δ	4.1	Fractional pressure decrease in noble gas processing volume during analysis
ΔP_G	4.3	Pressure increase due to outgassing
ΔP_L	4.3	Pressure increase due to leak
ΔS	4.3	Correction to pump speed arising from rate of change of pressure
ϵ	4.1, 7.1	Maximum acceptable value of δ
t	4.2	Time for probe to descend one pressure scale height
A	4.3	Internal surface area of instrument
C	4.1, 4.2, 7.1	Pump capacity
F	4.3	Leak in instrument, conductance
F	6.1	Calibrated test leak, conductance
F_o	4.1, 4.2, 7.1	Inlet leak, conductance
F_l	4.1, 7.1	Conductance between processing volume and ion source
F_l	4.2	Conductance between intermediate volume and ion source
f	4.1, 7.1	Ratio of active to noble gas pressure after enrichment
F_{oo}	4.2	Inlet conductance, value at planet surface
F_{crit}	4.3	Leak in instrument, minimum value which will preclude ion pump operation at entry
K	4.2	Exponent, dependence of conductance on pressure
P	4.1	Pressure, processing volume
P	4.3	Pressure, instrument
P	6.1	Pressure, test chamber
P_o	4.3	Pressure, exterior to instrument
P_o	6.1	Pressure, high side of calibrated leak

2 LIST OF SYMBOLS (Continued)

<u>Symbol</u>	<u>Section</u>	<u>Use</u>
P_1	4.2	Pressure, intermediate volume
P_I	4.1, 4.2	Pressure, ion source
$P(A)$	4.1	Partial pressure, active gas in processing volume
$P(N)$	4.1	Partial pressure, noble gas in processing volume
P_{max}	4.1, 7.1	Maximum ion source pressure
$P(A)_v$	4.1, 7.1	Partial pressure, active gas in Venus atmosphere
$P(N)_v$	4.1, 7.1	Partial pressure, noble gas in Venus atmosphere
$P(N)_I$	4.1	Partial pressure, noble gas in ion source
P_v	4.2	Pressure, Venus atmosphere
P_{vo}	4.2	Surface value of P_v
P_{vmin}	4.2	Value of P_v at 70Km
P_{crit}	4.2	Maximum at which ion source will start
Q	4.1, 6.1	Quantity of gas pumped
R	4.3	Outgassing rate
R_{crit}	4.3	Minimum outgassing rate which will preclude ion pump operation at entry
S	4.1, 4.2, 6.1, 7.1	Getter pump speed
S_T	4.1, 4.2, 7.1	Total pumping speed out of ion source
t	4.1, 4.2, 6.1	Time parameter
T_1	4.1, 7.1	Intake time interval for noble gas experiment
T_2	4.1, 7.1	Time interval between intake and analysis
T_3	4.1, 7.1	Analysis time interval
T	4.3	Time interval from vacuum scaling of instruments to Venus entry

2 LIST OF SYMBOLS (Continued)

<u>Symbol</u>	<u>Section</u>	<u>Use</u>
T	6.1	Pumping time interval
V	4.1, 7.1	Volume, processing chamber
V	4.3	Volume, instrument
V	6.1	Volume, test chamber
v_i	4.1, 6.1	Valve designator

3. INTRODUCTION

This report describes an investigation of sorption pumps relative to applications associated with the Pioneer Venus Descent Probe Mass Spectrometer Experiment. The study consists of four distinct but related tasks.

- (a) Establishment of pump requirements - discussed in Section 4.
- (b) A survey of existing sorption pumps - discussed in Section 5.
- (c) Tests of SAES ST 101 pumps - discussed in Section 6.
- (d) Preliminary pump design - discussed in Section 7.

The pumping materials considered in this study can be distinguished from other chemical pumps in that they remove gas by sorption processes rather than by bulk chemical reaction.

In establishing requirements for pumps we have considered three applications related to the Pioneer Venus Probe Mission.

- (a) An experiment to determine relative abundance of noble gases.
- (b) Pressure reduction from levels of the Venus atmosphere to levels compatible with operation of ion source.
- (c) Vacuum maintenance within the mass spectrometer during the period prior to atmospheric entry.

Each of these applications is closely tied to the design of the basic Mass Spectrometer Experiment. Since details of the basic experiment are not available at this time, requirements have been developed in a parametric fashion. Quantitative requirements are given for examples which are considered representative of the likely experiment configuration.

The survey of existing materials was directed toward the presentation of parameters significant in the use of a sorption pump in the applications mentioned above. These parameters include:

- (a) Pumping speed per unit mass.
- (b) Pumping capacity per unit mass.
- (c) Ultimate pressure.
- (d) Activation procedures.
- (e) Operating temperatures.
- (f) Specificity for certain gases.

Much of the information which is required for a determination of the usefulness of different types of pumps for the Pioneer Venus applications is currently unknown even to the manufacturers. An experimental program is recommended to supply this information where a material appears attractive in terms of what is known about it.

The testing task reported in Section 6 was performed to evaluate SAES ST 101 (Zirconium Aluminum) pumps for the Pioneer Venus applications. Based on information available prior to the start of the study this material appeared suitable for use in perhaps all three applications. ST 101 has been investigated to the point that specific recommendations as to its use are made.

The ST 101 material is sufficiently promising that a preliminary design for a pump using this material in a noble gas experiment has been performed. This design provides specification sufficient for production of an experiment definition level model of a noble gas inlet.

4. PUMP REQUIREMENTS

Sorption pumps have been considered for three Pioneer Venus Mass Spectrometer applications: a noble gas experiment, an atmospheric pressure reduction system, and cruise phase vacuum maintenance. The requirements for pumps used in these applications are distinct and are discussed in detail in the following paragraphs.

4.1 Noble Gas Experiment

Noble gases are expected in the Venus atmosphere in relative abundances of the order of 10^{-4} . In order to obtain information about isotopic ratios and abundances of noble gases present in low abundance it is necessary to present the ion source with a gas sample in which the noble gases have been enriched relative to the active gases. A pump used for this purpose would optimally have high speed to mass and capacity to mass ratios, a low ultimate pressure and high specificity for active gases. In order to establish quantitative requirements for a pump to be used in such an experiment one must consider the pump in the context of the Pioneer Venus Mission and the mass spectrometer experiment requirements.

It is assumed here that the noble gas measurement would be made with the instrument from the primary mass spectrometric atmospheric analysis experiment. At some point in the descent of the large probe, at an altitude where there is reasonable certainty of turbulent mixing*, the inlet system for the primary experiment is valved off and a noble gas enriched sample is introduced. Unless the noble gas experiment is made just prior to planetary impact the primary inlet will be reopened subsequent to the noble gas analysis. The tradeoff between the added valving complexity associated with performing the noble gas experiment at altitude and

*This requirement is probably satisfied throughout the large probe descent.

the danger of losing the data from this analysis by postponing it to the interval immediately prior to impact cannot be resolved here. Hence we will assume that the noble gas analysis is performed at an unspecified altitude and will obtain requirements in terms of the measurement altitude. In Section 7 these generalized requirements will be made definite in the design of a specific pump.

The system considered is shown schematically in Fig. 4.1. The operational sequence for this system is as follows:

- (a) Valve v_1 opens allowing atmospheric gas to flow into the processing volume through a flow constriction, F_o . The active gas in the processing volume is pumped at a speed, S , while the noble gas component accumulates, unpumped.
- (b) After an interval, T_1 , valve v_2 is closed. Prior to this time the active gas pressure in the processing volume has been determined by an equilibrium between flow through the inlet leak and the rate of pumping. With the inlet flow terminated the active gas pressure decreases. The unpumped noble gas remains at a constant pressure after the inlet flow is stopped.
- (c) When the active gas component has been suitably reduced, a time, T_2 , after v_2 was closed, the gas sample is ready for introduction into the mass spectrometer.
- (d) Valve v_3 is opened when the noble gas analysis begins. The analysis is accomplished in a time interval, T_3 .
- (e) At the end of the analysis valve v_4 is closed.

This sequence of operations and the hardware parameters are subject to a set of constraints:

- (a) After enrichment the ratio of active gas pressure, $P^{(A)}$, to noble gas pressure, $P^{(N)}$, is to be reduced to at most a value, f . When f is too large the sensitivity to noble gases present in the atmosphere in small relative

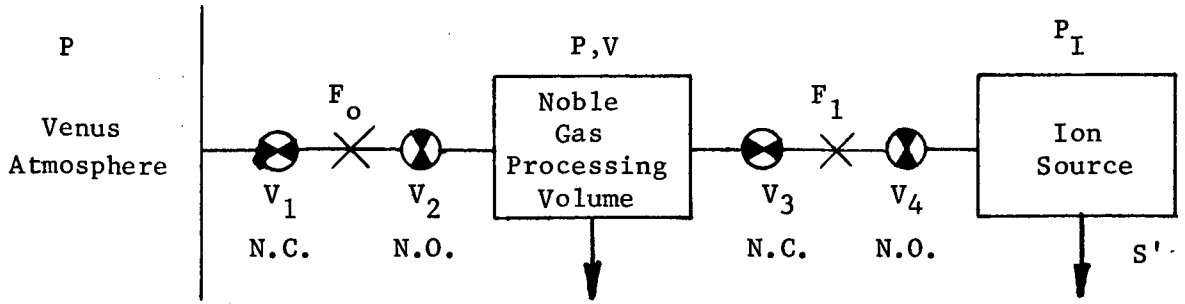

Schematic of Noble Gas Inlet System

Figure 4.1

abundances is restricted. When the active gas is reduced to less than 10% of the sample little is gained from further enrichment. It is, thus, concluded that f should be somewhere between 1 and 0.1.

$$0.1 \quad f \leq \frac{P^{(A)}}{P^{(N)}} \leq 1.0 \quad (4.1)$$

- (b) During the analysis interval the source of enriched gas should be maintained, within limits, at a constant pressure. If the analysis consists of a single scan this will require pressure constancy (or knowledge) within the limits of desired experimental accuracy. If multiple scans are made and these data are used to determine the rate of decay of source gas pressure, a somewhat larger loss of gas pressure would be allowable. It is expected that the allowable fractional loss, ϵ , will be of the order of 10^{-1} or less.
- (c) In order to maximize the sensitivity of the experiment it is desirable to maintain the ion source pressure at nearly its maximum operating value, P_{\max} . This value can be expected to be approximately 1.33×10^{-4} newton per meter² (10^{-6} torr).
- (d) Most of the gas admitted through the inlet leak will be pumped by the processing pump. This establishes a constraint involving intake time, pump capacity, inlet leak conductance, and intake altitude or pressure.

While v_1 and v_2 are both open the active gas pressure, $P^{(A)}$ in the processing volume is determined by equilibrium between inlet flow and pumping speed. Indicating the partial pressure of active gases in the Venus atmosphere by $P_v^{(A)}$ one has,

$$P_v^{(A)} F_o = P(T_1) S \quad , \quad (4.2)$$

throughout most of the intake interval. Implicit in this statement is the assumption that the pressure equilibrium is achieved in a time short compared to the intake interval T_1 . This assumption can be shown valid for the system description which evolves from this analysis. During the same intake interval the noble gas pressure rises linearly, there being a noble gas pumping rate of zero and the atmospheric pressure exceeding the processing volume pressure by many orders of magnitude. The noble gas pressure in the processing volume is given by,

$$P(t) = P_v^{(N)} \frac{F_o}{v} t \quad , \quad (4.3)$$

During the intake interval, or

$$P(T_1) = P_v^{(N)} \frac{F_o}{v} T_1 \quad (4.4)$$

at the end of the interval.

When the valve v_2 is closed the sorption pump reduces the active gas pressure exponentially. Unless the ultimate pressure of the pump becomes a factor (an ultimate pressure less than $1.33 \times 10^{-3} \text{ N/m}^2$ (10^{-5} torr) will be seen to be sufficiently low) the active gas pressure in the processing volume will be given by

$$P(T_1+T_2)^{(A)} = P_v^{(A)} \frac{F_o}{S} e^{-\frac{ST_2}{v}} \quad (4.5)$$

at the end of the processing interval. The noble gas pressure, unaffected by the sorption pump, remains unchanged during the processing interval.

$$P(T_1+T_2)^{(N)} = P_v^{(N)} \frac{F_o}{v} T_1 \quad (4.6)$$

After valve v_2 is closed and v_3 is opened gas leaks from the processing volume into the ion source through a conductance, F_1 . The partial pressure of each component will decrease exponentially throughout the analysis interval, T_3 in duration. If the flow through the leak is molecular or transition in nature the decay rates will differ somewhat. We assume here identical rates. This is done for purposes of simplicity and does not affect the analysis in any qualitative way. The processing volume partial pressures during the analysis interval are

$$P^{(A)}(T_1+T_2+t) = P_v^{(A)} \frac{F_o}{S} e^{-\frac{ST_2}{v}} e^{-\frac{F_1 t}{v}} \quad (4.7)$$

and

$$P^{(N)}(T_1+T_2+t) = P_v^{(N)} \frac{F_o}{v} T_1 e^{-\frac{F_1 t}{v}} \quad (4.8)$$

During the analysis interval the ratio of active gas abundance to noble gas abundance in either the processing volume or the ion source is given by

$$\frac{P^{(A)}}{P^{(N)}} = \frac{P_v^{(A)}}{P_v^{(N)}} \frac{v}{ST_1} e^{-\frac{ST_2}{v}} \quad (4.9)$$

The fractional pressure decrease, δ , in the processing volume during the analysis interval is

$$\delta \equiv \frac{P(T_1+T_2) - P(T_1+T_2+T_3)}{P(T_1+T_2)} = 1 - e^{-\frac{F_1 T_3}{v}} \quad (4.10)$$

When this fraction is much less than 1 it can be approximated by

$$\delta \approx \frac{F_1 T_3}{v} \quad (4.11)$$

The total amount of gas, Q, pumped in the processing volume is given by

$$Q = P_v^{(A)} F_o T_1 \quad (4.12)$$

This equation determines the minimum capacity, C, for the processing pump. The pressure, P_I , in the ion source, during the analysis interval much lower than that in the processing volume, is determined by the pressure in the processing volume (equations 4.7 and 4.8), the conductance F_1 , and the total pumping speed, S_T , out of the ion source. S_T may well consist of the sum of the speed of an ion source pump and a conductance from ion source to analyzer. For the noble gas component, $P_I^{(N)}$, in the ion source during the analysis interval

$$\begin{aligned} P_I^{(N)} &= P^{(N)} \frac{F_1}{S_T} \\ &= P_v^{(N)} \frac{F_o}{v} T_1 e^{-\frac{F_1 t}{v}} \frac{F_1}{S_T} \end{aligned} \quad (4.13)$$

We now are in a position to make quantitative statements of the system constraints mentioned earlier. The enrichment requirement can be stated, using equation (4.9), as

$$\frac{P_v^{(A)}}{P_v^{(N)}} \frac{v}{S_T} e^{-\frac{S_T t}{v}} < f_c. \quad (4.14a)$$

Using equation (4.11) the stability of source gas pressure constraint becomes

$$\frac{F_1 T_3}{v} \leq \epsilon \quad (4.14b)$$

The constraint on ion source pressure becomes, using equation (4.13) at the beginning of the analysis period ($t=0$),

$$P_v^{(N)} \frac{F_o}{v} \frac{F_1}{S_T} T_1 \leq P_{\max} \quad (4.14c)$$

Finally, the capacity, C, of the processing pump must be at least equal to the quantity of active gas admitted to the system (equation 4.12)

$$P_v^{(A)} F_o T_1 < C \quad (4.14d)$$

Equations (4.14), together with a general requirement to diminish weight, provide design constraints for the noble gas inlet system, including the active gas specific pump. In Section 7 these equations will be used in the design of a pump for such an inlet.

4.2 Atmospheric Pressure Reduction System

An atmospheric pressure reduction system should reduce the ambient pressure to a level at which an ion source can function satisfactorily. To avoid loss of sensitivity of the mass spectrometer system the pressure in the ion source should not drop much below its maximum operating value. This pressure reduction to an essentially constant ion source pressure could be accomplished with multiple inlet systems used in sequence, by means of a variable speed pump or by means of a fixed speed pump with a variable inlet orifice. Since the pumps considered in this study are essentially fixed speed devices we will consider the latter approach.

The system considered here is the two stage reduction system shown in Figure 4.2. The major portion of the gas entering the system goes from the intermediate volume into the reduction pump. The conductance of the variable valve into the pump volume is controlled so as to maintain the pressure in the intermediate volume at a constant level. We will analyze the system of Figure 4.2 to establish requirements for the pump.

When the probe reaches the planet surface the variable

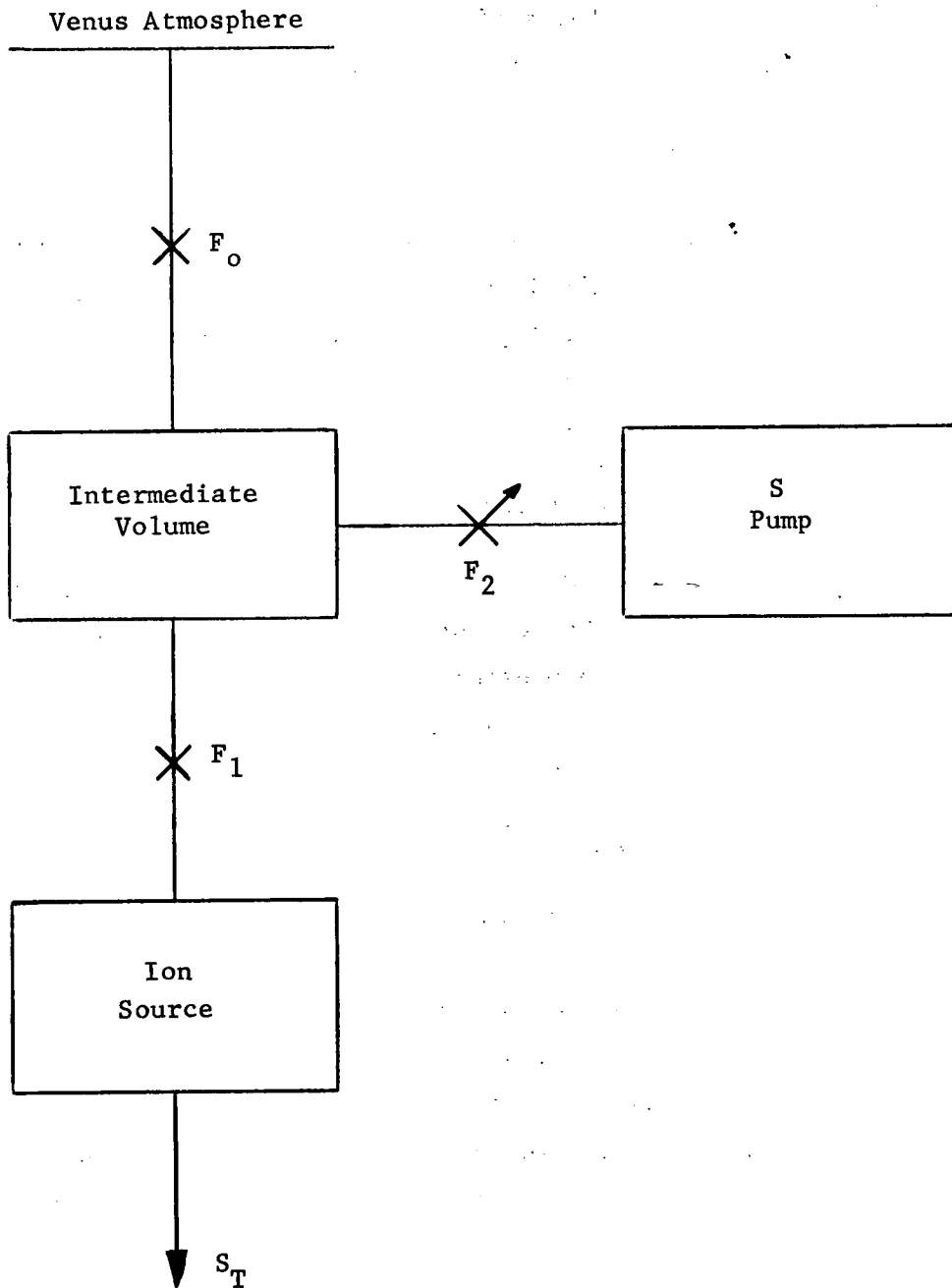

Figure 4.2
Schematic of Two Stage Pressure Reduction System

conductance is fully open and, neglecting the minor flow through the ion source, one can write the following relation between surface atmospheric pressure, P_{vo} , the surface value, F_{oo} , of the inlet conductance, the intermediate volume pressure, P_1 , and the reduction pump speed, S .

$$P_{vo} F_{oo} = P_1 S \quad (4.15)$$

The capacity, C , of the pump is determined by the amount of gas which flows through the inlet conductance during the descent. Because of likely pre-entry use of the pump (in system test, for instance) and to allow design margin the capacity of the pump will exceed the anticipated amount of intake gas.

$$C > \int_0^T P_v(t) F_o(P_v) dt \quad (4.16)$$

Here T is the descent time and $P_v(t)$ depends upon the atmospheric pressure profile and the probe descent rate profile. The inlet conductance, F_o , depends upon pressure and can be written in terms of the conductance, F_{oo} , at the planet surface as follows:

$$F_o = F_{oo} \frac{P_v}{P_{vo}}^K \quad (4.17)$$

The exponent K is equal to 1 for a viscous leak and equal to 0 for a molecular leak.

For purpose of estimating the capacity of the reduction pump it is convenient to approximate the pressure versus time profile by an exponential function increasing from the pressure at 70 Km altitude to the surface pressure in a time interval equal to the descent period. This leads to the following expression for the capacity.

$$C \gtrsim \frac{F_{oo} P_{vo} t}{1+k} \quad (4.18)$$

Here t is the time required for the probe to fall through an altitude interval corresponding to a pressure increase of e (2.71...).

The inlet conductance at maximum altitude can be established by requiring that with the variable conductance, F_2 , completely closed the pressure in the intermediate volume must be equal to the constant value, P_1 . This leads to

$$P_{vmin} F_o = P_1 F_1 = P_I S_T \quad (4.19)$$

where P_{vmin} and F_o are the pressure at 70 Km altitude and the corresponding inlet conductance, and P_I is the desired ion source pressure.

The operating pressure in the intermediate volume becomes a system design parameter. As an example take the intermediate volume pressure to be 133 Newton/meter² (1 torr). Mass spectrometer sampling, through a single construction, of gases at a pressure of this level is fairly routine. Take as a representative ion source pressure 1.33×10^{-4} N/m² (10^{-6} torr). Further assume the flow speed out of the ion source to be 10^{-4} (meter)³/second (0.1 liter/second) and the inlet leak to be viscous. For Venus pressures of 2.9×10^3 N/m² at 70 Km and 9.7×10^6 N/m² at the surface and a descent time of 3600 seconds, one has, from equation (4.19), for the inlet conductance at an altitude of 70 Kilometers

$$F_o = 4.5 \times 10^{-11} \text{ (meter)}^3/\text{sec} , \quad (4.20a)$$

and then from equation (4.17) a conductance at the surface of

$$f_{oo} = 1.5 \times 10^{-7} \text{ (meter)}^3/\text{sec} . \quad (4.20b)$$

The time interval, t , is 445 seconds. So, from equation (4.18)

$$C \gtrsim 32 \text{ Nm (240 torr liter)} \quad (4.21)$$

Finally from equation (4.15) we have the required pump speed

$$S = 1.1 \times 10^{-2} \text{ (meter)}^3/\text{sec} \quad (4.22)$$

If the pump used in this sort of system pumps some molecules selectively then the pressure in the intermediate volume becomes an important design consideration. The pressure level in this volume should be high enough that flow through the variable conductance into the pump volume is viscous. Under this condition all gases in the intermediate volume flow into the pump volume at a rate determined by the viscosity of the bulk gas. Used in this way the selectivity of the pump does not alter the relative abundance of the gases in the intermediate volume from which the ion source receives its input.

4.3 Vacuum Maintenance

After a sealed instrument is delivered for installation on the Pioneer Venus probe, an interval of the order of 10^7 seconds passes before entry into the Venus atmosphere. For the first part of this interval the instrument is subjected to a pressure differential of one atmosphere of air. Later during the cruise phase of the mission the instrument is subjected to the internal pressurization of the probe, quite likely one atmosphere of dry nitrogen. So, for a period of the order of 10^7 seconds the instrument is exposed to an exterior pressure of approximately 10^5 Newton/meter². A leak in the instrument will cause the internal pressure to rise during this interval. At the same time interior walls of the instrument will outgas adding another contribution to the internal pressure. If, as seems likely, an ion pump is used in the mass spectrometer this pump will be turned on shortly before Venus entry. If the internal pressure has risen above a critical level (something like 10^{-2} Newton/meter²) there is a high probability that the ion pump will not start. The simple calculation below establishes what the critical outgassing and leak rates are.

If the outgassing rate per unit surface area is R, the internal surface area A, the internal volume V, the external pressure P, and there is a leak with a conductance F, then the internal pressure increase, P_G , due to outgassing is given, after a time T, by

$$P_G = \frac{RAT}{V}, \quad (4.23)$$

and the increase, P_L , due to the leak is given by

$$P_L = \frac{PFT}{V}. \quad (4.24)$$

These equations can be used to write expressions for the critical outgassing rate and critical leak size associated with the internal pressure, P_{crit} , critical to the starting of an ion pump. For the critical outgassing rate, R_{crit}

$$R_{crit} = \frac{P_{crit}V}{AT}. \quad (4.25)$$

For the critical leak size

$$F_{crit} = \frac{P_{crit}V}{PT}. \quad (4.26)$$

Consider the example

$$P_{crit} = 10^{-2} \text{ Newton}/(\text{meter})^2$$

$$V = 10^{-3} (\text{meter})^3$$

$$A = 10^{-2} (\text{meter})^2$$

$$P = 10^5 \text{ Newton}/(\text{meter})^2$$

$$\text{and } T = 10^7 \text{ seconds.}$$

For this example

$$R_{crit} = 10^{-10} \text{ N/msec} \left(7.5 \times 10^{-14} \frac{\text{torr liter}}{\text{sec cm}^2} \right) \quad (4.27)$$

and

$$F_{\text{crit}} = 10^{-17} \text{ m}^3/\text{sec} \cdot 10^{-14} \text{ liter/sec} . \quad (4.28)$$

Both of these values are sufficiently small as to make it clear that even a well baked and sealed instrument cannot, with confidence, be taken to Venus without some sort of vacuum maintenance. This vacuum maintenance could be accomplished by periodically turning on the ion pump. An alternate approach would be to carry, within the instrument, a quantity of getter material, activated on earth and operative under ambient probe temperature conditions.

If an outgassing rate R and a leak rate F together with a pressure differential, P_o , are to cause an instrument pressure at no greater than P_{max} because of use of a getter pump, that pump must have a speed S and a capacity C given by

$$S = \frac{RA}{P_{\text{max}}} \quad \text{or} \quad \frac{P_o F}{P_{\text{max}}} \quad (4.29)$$

whichever is larger

$$\text{and} \quad C = RAT \quad \text{or} \quad P_o FT \quad (4.30)$$

whichever is larger.

A getter pump with a speed of $10^{-4} (\text{meter})^3/\text{sec}$ and a capacity of 0.1 Newton/meter (.75 torr liter) would be capable of handling leak or outgassing rates four orders of magnitude larger than those specified in equations (4.27) and (4.28) and maintain the pressure at less than 10^{-4} Newton/meter². If the gettering material can be attached to existing structure the weight penalty for this sort vacuum maintenance over 10^7 seconds is of the order of 10^{-2} Kg with existing materials.

Some care should be exercised in using getter pumps for vacuum maintenance when the problem is a leak in the earth's atmosphere. The earth's atmosphere contains approximately 1% Argon and many gettering materials will not pump Argon. Aboard the probe the

the gas which might leak into the instrument is likely to be high purity dry nitrogen and there no such problem will exist with the non-pumping of noble gases.

5. SORPTION PUMP SURVEY

Materials considered for this survey are bulk getters in which the gas sorbs on the surface, or goes more deeply into the pores, or diffuses into the material.

Within this section a list of getters that have been investigated is itemized. Some are eliminated after preliminary consideration. The reason for their elimination is stated. Others are described later with their characteristics defined when possible and when unknown so stated. Parallel comparisons of speed, capacity, temperature of operation, operating pressure, ability to sorb different gases, configuration, manufacturer, and mode of activation are made for the most promising materials.

5.1 Limitations

The following limitations have been placed on this survey: The getter must sorb the gas and not produce a by-product. The getter must either operate at the environmental temperatures inside the probe or operate at some temperature outside the probe where the Venus atmosphere will heat the getter. The mass of the getter and the volume of the container holding the getter needs to be kept to a minimum.

In the light of these limitations several bulk getters were found that have promise for use in the mass spectrometer experiment.

5.2 Discussion of Comparison Parameters

Several getter parameters are considered in the study and are discussed below. Some of the parameters are interconnected and these connections will be pointed out in the discussion.

The capacity per unit mass is important. It is desirable to maximize this parameter. Pumping speed/mass is desired to be maximum. The getter requirements are different for the three pumping applications. In the noble gas pump a getter material is desired

that pumps the active gases but not the noble gases. This getter must have a high pumping speed for CO_2 and a speed for N_2 that is at least 5% of that for CO_2 . It must also pump CO. In the atmospheric pressure reduction pump a getter is desired that would pump all the gases with fastest rates for CO_2 and N_2 . If the noble gases are not pumped then the degree of pressure reduction is limited. The maximum operating pressure of a getter is an important consideration since this sets the maximum pressure at which the gas can be pumped. Inlet conductances to the noble gas pump need to be of the right value so the maximum allowable pressure is never exceeded. A pump used in the mass spectrometer needs good pumping capacity for hydrogen, which is a common outgassing product and should produce no by-products in the process of pumping the hydrogen. It should have some nitrogen pumping capability. The operating temperatures for this getter will be from 295 K to 360 K.

Configuration of available pumping elements are significant since this relates to the amount of design and development time required before an operating pump is available for the program.

The source of the getter material has some significance. Areas of concern are the interest of the supplier in developing the product for a Pioneer Venus application, their knowledge of the product, and their current programs in developing new getter products. One area of some concern is the location of the manufacturer. The manufacturer of a particularly promising class of getters is located in Italy. If their product is chosen, working with them is more costly and more difficult. In the process of developing such a pump, visits to the manufacturer are essential. This will be an additional cost factor.

Activation of the getter is an important consideration. Most getters must be evacuated before being used and all must be

kept evacuated until used in the experiment. Some require high temperature for a few seconds and if saturated can be reactivated; however, in general when reactivated, they have less capacity than before the first saturation. Other getters, when saturated, cannot be activated again and still others if activated and evacuated again, are as good a getter as upon first usage.

5.3 Getter Materials

The following types getter materials have been considered in this study. Some of these are immediately eliminated for the reasons stated in this paragraph. Some of the materials listed here are given by trade names and unless immediately eliminated their composition will be discussed later.

Zirconium Aluminum - operates best at 670 K. Will pump hydrogen and nitrogen at a reduced rate at 295 K. Pumps active gases but no noble gases.

Zirconium Graphite - Pumps at 295 K and also at 670 K but capacity/mass ratio at higher temperature poorer than zirconium aluminum. Pumps active gases but no noble gases.

Ceralloy 400 - Operates at 670 K. Capacity/mass ratio slightly larger than zirconium aluminum. Pumps active gases but no noble gases.

Zirconium Titanium - Active at 670 K. Pumps active gases but not noble gases.

Zirconium - Lower capacity than Zr Ti by a factor of 100. Not active at 300 K. Thus eliminated from further study in this survey.

Titanium - Lower capacity than Zr Ti by a factor of 1000. More active than Zr at room temperature. Might be useful in vacuum maintenance to maintain low pressure during cruise phase. Requires electrical power to sublime and make a new surface.

Synthetic Zeolites called Linde Molecular Sieves

Type 4a, 5A - Pump gases at 295 K and their capacities decrease as the temperature increases. Capacities increase as the pressure increases. May pump some noble gases at 295 K. Have large capacities for CO₂ at higher pressures.

Silica Gel - Considerably lower capacity than zeolites at the same temperature. Eliminated from further consideration.

Carbon - Considerably lower capacity than zeolites at the same temperature. Eliminated from further consideration.

Other materials are mentioned in the literature but eliminated for lack of information. They include hydrated ferric oxide and alumina and many metals which include iron, nickel, tungsten, tantalum, and magnesium.

5.4 Specifications and Comments of Getter Candidates

In searching the literature for getters that are useful for the Pioneer Venus Mass Spectrometer Experiment one finds pumping parameters stated in several ways. There are also voids in the information. An itemized list and/or discussion for each material is given in the following text for the known parameters and where the information is missing, its absence is indicated.

5.4.1 Zirconium Aluminum (SAES ST-101) (1)

a) Capacity/Mass and/or Surface Area

Zirconium aluminum is an alloy of 84% zirconium and 16% aluminum. This getter is bonded to both sides of thin strips of mild steel. The pump evaluated in our laboratory has a total mass of .645 Kg with .409 Kg of getter material. The capacity of this pump is $26.6 \text{ (N/m}^2\text{) m}^3$ or (200 torr ℓ) of CO₂. This pump has 0.45 m^2 of surface so the capacity of this pump is $59 \text{ (N/m}^2\text{) m}^3$ per square meter of surface or

$$(4.4 \times 10^{-2} \frac{\text{torr } \ell}{\text{cm}^2}) \text{ or } 54.6 \frac{\text{N}}{\text{M}^2} \frac{\text{M}^3}{\text{Kg}} \text{ or } \left(\frac{.490 \text{ torr } \ell}{\text{g}} \right)$$

This material has a large capacity for hydrogen and at 300 K can pump 1.33×10^2 Newton/meter ($.1 \text{ torr } \ell/\text{cm}^2$) and has possible utility as the vacuum maintenance pump.

b) Speed/Mass or Speed/Surface Area

The speed of this material varies as a function of pressure, gas being pumped, enclosure, and amount of gas pumped. A nude pump is faster than the enclosed pump, however, an enclosed pump is necessary in the applications considered here. This pump was found to have similar speeds for CO_2 and N_2 at $4 \times 10^{-1} \text{ N/m}^2$ or ($3 \times 10^{-3} \text{ torr}$) which was $1.2 \times 10^{-2} \text{ m}^3/\text{Kg sec}$ or ($1.2 \times 10^{-2} \ell/\text{g sec}$) of gettering material. These speeds were made with the getter operating at 670 K. Detailed results of these findings are presented in Section 6.

c) Specificity

The zirconium aluminum getter pumps active gases at different rates but for N_2 , O_2 , CO , and H_2 , the pumping speeds are all within a factor of 4 of one another. Noble gases are not pumped.

d) Operating Temperatures

This material operates best as a getter at 670 K but will operate at 300 K. The capacity for hydrogen at the lower temperature is reduced by about 50%. The speed for hydrogen is unknown at the lower temperature.

e) Operating Pressures

Maximum and minimum pressures are unknown.

f) Configurations

This material comes in several configurations in small rings, plates and in several sizes similar to to the one shown in Figure 5.1. This configuration is especially attractive for use in an enclosure outside the Venus probe where the Venus atmosphere will heat the enclosure. Since the accordion pleats are close together they make an excellent heat sink.

g) Special Requirements

These materials must be activated before usage. Once exposed to air they must be reactivated. After activation and saturation they can be re-activated. Their capacity decreases approximately 10% after each cycle.

h) Source

This zirconium aluminum getter has a trade name of ST-101 and is manufactured by SAES:

Societa Apparecchi Elettrici e Scientifici
Via Gallarate 215
1-20151 Milano, Italy

with an American office of:

Getters Electronics Inc.
P. O. Drawer 433
Hamburg, New York 14075
Tele: (716) 649-5865

SAES specializes in the development and manufacture of getters. They make this material in several sizes and shapes. Current research is going on in the development of new materials.

i) Activation

This material must be activated before use. This is done by heating it to temperatures of

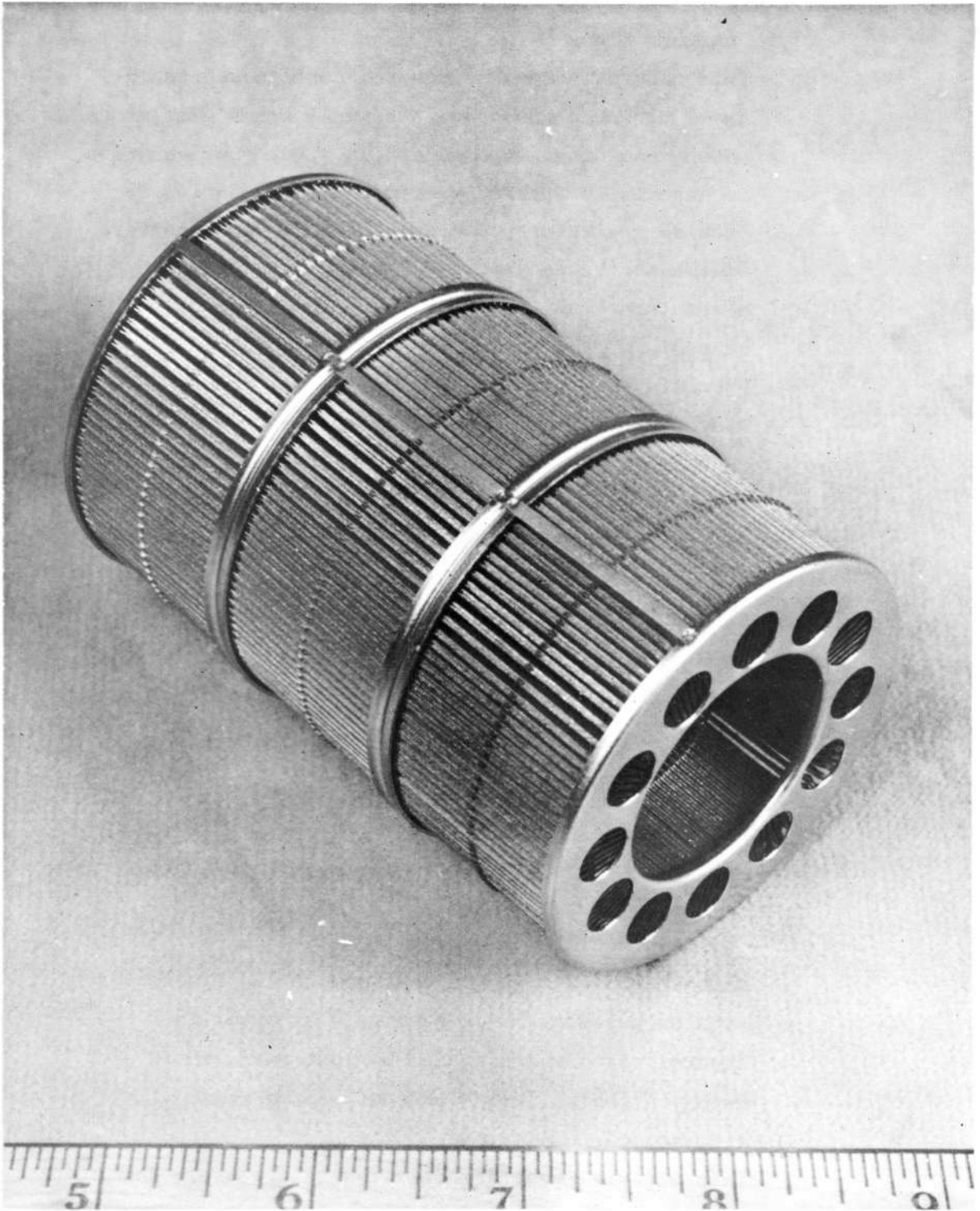

Figure 5.1 Zirconium Aluminum Getter

1075 \pm 50 K for 15-20 seconds at a pressure below $1.3 \times 10^{-1} \text{ N/m}^2$ (10^{-3} torr). Reactivation is done at the same temperature. During the activation period large quantities of hydrogen are released. The material changes from $\text{Zr}_5 \text{Al}_3$ to $\text{Zr}_4 \text{Al}_3$ and intermediate compositions which increases the molecular surface area per unit geometrical area.

5.4.2 Material Zirconium Graphite (SAES ST-171)(2)

a) Capacity/Mass

This material is attractive since it pumps active gases at 300 K. It has a capacity for the following gases. The capacity is stated in $(\text{N/m}^2)\text{m}^3$ per kg or (torr ℓ/g).

Table 5.1

Gas Capacity for Zirconium Graphite		
	298 K	675 K
CO	4.4 (0.033)	26.6 (0.2)
N ₂	1.77 (0.013)	10.6 (0.8)
H ₂	89 (0.67)	440 (3.3)
CO ₂	Unknown	Unknown
O ₂	Unknown	Unknown

b) Speed/Mass

The speed in $\text{m}^3/\text{Kg sec}$ or $\ell/\text{g sec}$ is the same numerical value and is shown in the table 5.2.

Table 5.2
Pumping Speed for Zirconium Graphite

	298 K	675 K
CO	6.5	8
N ₂	4.0	40
H ₂	10	10
CO ₂	Unknown	Unknown
O ₂	Unknown	Unknown

These are the initial measured speeds for nitrogen when the pressure is an equivalent of 4×10^{-4} N/m². When the speed has gone down 80% the getter is considered to be saturated. No information is available at other pressures.

c) Specificity

This getter pumps active gases and no noble gases. During activation of the getter in our laboratory large quantities of hydrogen were released. The gas released was more than a 0.05 m³/sec ion pump could handle and the ion pump shut off because of the excessive gas being evolved. Not all of the released hydrogen was evacuated and some was adsorbed back into the getter when cooled. After the getter was cooled background scans on the mass spectrometer were made of the residual gases. All gases had pressures less than 10^{-7} N/m². Then the ion pump was isolated from the rest of the system. The getter pump was the only pump pumping on the mass spectrometer. In this condition the methane peak rapidly increased to the 10^{-4} N/m²

region. The valve to the ion pump was opened and the methane peak disappeared. The power to the filament on the mass spectrometer was shutt off and the valve closed to isolate the ion pump from the system. A few minutes later, the power was applied to the filament and the methane peak was in the 10^{-4} N/m² region. The test is not conclusive but methane may be desorbing from the getter. Dr. Giorgi⁽³⁾ at SAES stated this could be either reduced or eliminated by activating at lower pressures. A faster pumping system was not immediately available so this has not been proven.

d) Operating Temperatures

One of the features of this getter is that it has significant speed at 295 K and can be useful without adding energy. It has greater capacity at 675 K. ST-101 has superior properties to those of ST-171 at the higher temperature. For this reason ST-171 appears promising only for low temperatures (300 K) operation.

e) Operating Pressure

The only available information on this getter was obtained when operating at a pressure equivalent to 4×10^{-4} N/m² of nitrogen or lower.

f) Configuration

Figure 5.2 is a picture of the getter tested at Martin Marietta. It has a built in heater for activation and for operation at higher temperatures. This model and one slightly smaller are currently available. The mass of this getter including heater and leads is 3.4×16^{-3} kg.

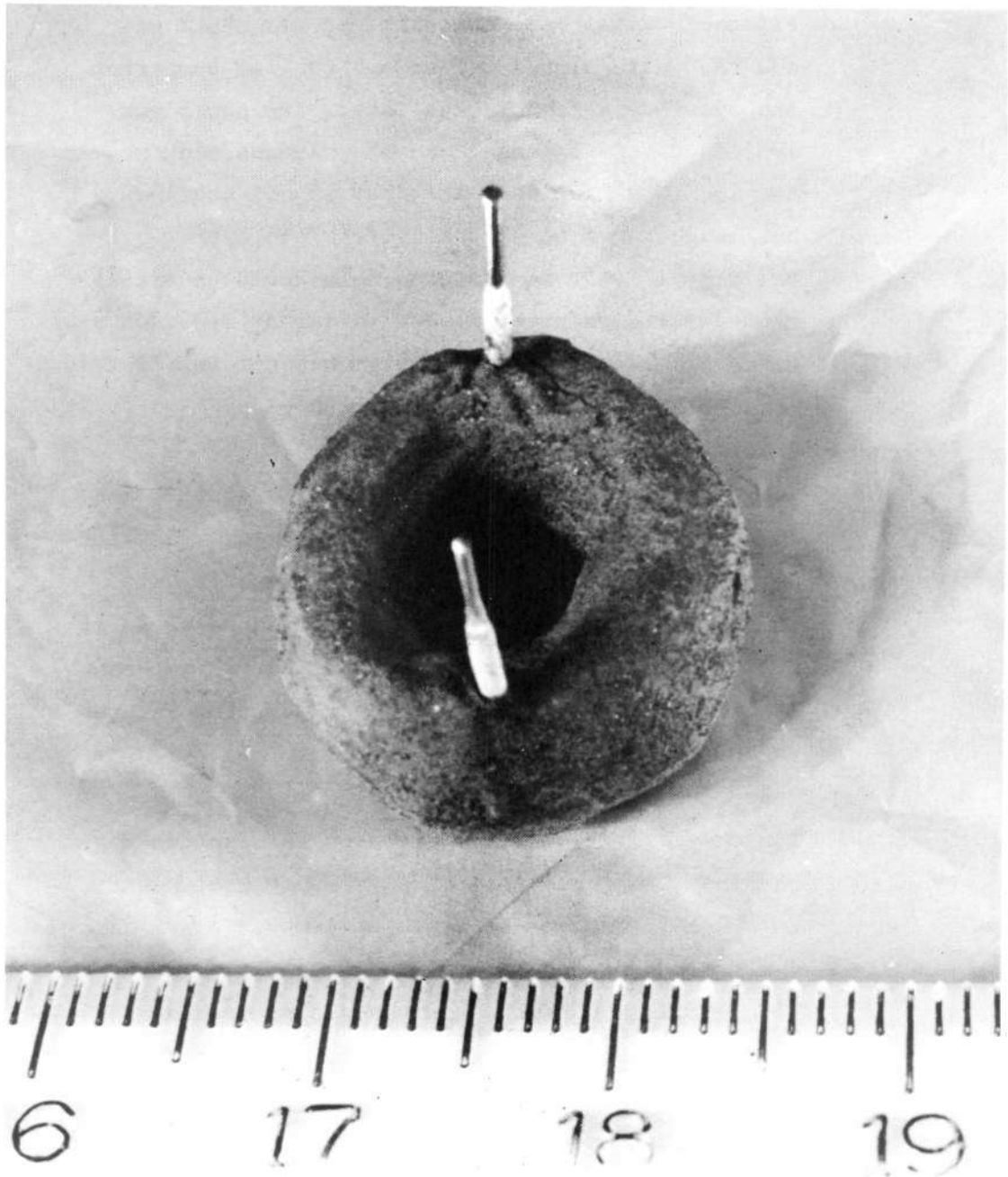

Figure 5.2 Zirconium Graphite Getter. Scale-Smallest Division 1×10^{-3} m. Mass of Getter 3.4×10^{-3} Kg.

g) Source

This getter called ST-171 is manufactured by SAES whose address is given in Section 5.4.1 h).

h) Activation

The activation of zirconium graphite requires a temperature of 1175 K to 1273 K at a pressure no greater than $1 \times 10^{-4} \text{ N/m}^2$. A period of ten minutes is required at 1175 K and one minute at 1273 K. A diffusion or turbo molecular pumped system with high pumping speeds for hydrogen is required to maintain the required pressure. This getter can be reactivated by heating to similar temperatures for the same period. The capacity decreases after each saturation and activation cycle. If activated and exposed to atmospheric pressure it must be reactivated.

5.4.3 Cer Alloy 400

a) Capacity/Mass

Cer Alloy 400 is composed of 80% thorium, 5% aluminum, and 15% rare earths. The pumping capacity is dependent upon the temperature. The information given below in Table 5.3 is in units of $\left(\frac{\text{N}}{\text{m}^2}\right) \text{ m}^3$ per kg and in (torr ℓ/g). The gas pressure during the test was $1.3 \times 10^{-1} \text{ N/m}^2$ or (1×10^{-3} torr). The tests were conducted on nickel strips 1×10^{-4} meters thick with getter coating mass of 10^{-1} Kg/m^2 or (10 mg/cm^2) on each surface.

Table 5.3

Capacity of Cer Alloy 400

	473 K	673 K	873 K
CO	Unknown	146 (1.10)	Unknown
N ₂	0.665 (0.005)	69.4 (0.522)	1.6 (0.012)
H ₂	434 (3.25)	12.1 (0.091)	Unknown
CO ₂	Unknown	293 (2.20)	118.50 (89.0)
O ₂	157 (1.18)	16.2 (0.122)	39.0 (0.292)

b) Speed/Mass

The speed for Cer Alloy 400 is dependent upon the temperature. Its speed is given in Table 5.4⁽⁴⁾ in m³/Kg sec. These speeds were made at a pressure of 1.3×10^{-1} N/m² or (10⁻³ torr).

Table 5.4

Pumping Speeds for Cer Alloy 400

	473 K	673 K	873 K
CO	0.002	2.67	0.154
N ₂	0.007	0.215	0.34
H ₂	0.015	0.29	Unknown
CO ₂	0.002	0.014	0.695
O ₂	0.153	0.15	0.04

The information found for the speed and capacity are somewhat under question⁽⁴⁾. First the tests were done in 1961 by using a hot filament ionization

pressure gauge. Pressures of $1.3 \times 10^{-1} \text{ N/m}^2$ are at the upper limit for this gauge. Errors of 50% are possible unless carefully calibrated. The experimenter even questions the measurement by noting that a flickering effect was observed at these pressures. These findings⁽⁵⁾ are also questioned by the suppliers but they have published little information to improve or nullify the results.

c) Specificity

Cer Alloy 400 has hydrocarbons formed after having pumped CO and the residual gases are about 50% hydrogen and the balance hydrocarbons.⁽⁶⁾ These increase as the temperature of the getter increases. Before saturation, partial pressures of these hydrocarbons are 3 or 4 decades below $1.33 \times 10^{-1} \text{ N/m}^2$, the pressure in which the experiment was conducted. No noble gases are pumped with this getter.

d) Operating Temperature

The operating temperature is best for CO₂ between 675 K to 875 K with an improvement of a factor of 80 at 875 K from 675 K. At 300 K there is no detectable pumping.

e) Operating Pressure

The maximum operating pressure range is unknown. The data presented herein were taken at $1.3 \times 10^{-1} \text{ N/m}^2$.

f) Configurations

The material comes in several forms⁽⁷⁾: paste, pellets, and coated metal strips. An explosive powder is also made but it cannot be shipped.

The pellets are shipped in a sealed container and ground under acetone. The paste can be applied to metal strips and heated under vacuum to 1200-1225 K for 45 minutes to cure and make a bond. Nickel strips are available with the getter applied on both sides where the getter mass is $8 \times 10^{-2} \text{ Kg/m}^2$ to $1 \times 10^{-1} \text{ Kg/m}^2$ or (8-10 mg/cm^2). The maximum size of the available strips is $2.54 \times 10^{-2} \text{ m} \times 1.27 \times 10^{-4} \text{ m} \times 2.2 \times 10^{-1} \text{ m}$.

g) Special Requirements

To date the manufacturer has a limited production and facility. If a larger sized piece is needed one must prepare ones own samples. To date their sales have not warranted larger production facilities.

h) Source

Cer Alloy 400 is manufactured in the United States by Ronson Metals Corporation, 45-65 Manufacturers Place, Newark, N. J. 07105. A similar getter is marketed in Europe under the name of Ceto. Evaluation, done by SAES and reported by della Porta⁽⁸⁾, relates that Cer Alloy 400 is a better N_2 getter than Ceto. However, the Ronson Metal Corp. has done very little development work on this material for several years. They have little or no development work going on now.

i) Activation

Cer Alloy requires no activation. When it is heated to an elevated temperature in vacuum it becomes an operative pump.

5.4.4 Zirconium Titanium

Zirconium Titanium, an alloy getter composed of

87½% Zr and 12½% Ti, is reported in a United States patent by Stout.⁽⁹⁾ Little information is given for the material except for a parabolic rate constant.

At 650 K it has a gettering capacity of 72 Newton meters of O₂ for the first minute. The pressure of the oxygen is unknown when these tests were conducted. Gettering rates for other gases are unknown.

In a Brochure supplied by Oregon Metallurgical Corporation (Oremet), Albany, Oregon, it states that the getter will remove gaseous impurities such as CO₂, CO, N₂, O₂, H₂, and water vapor from atmospheres contained in electronic devices and vacuum chambers. It is also used to purify inert gases down to a few parts/million. The material is available in chips which have nominal dimensions of 6.3 x 10⁻³ m x 6.3 x 10⁻³ x 7 x 10⁻⁴ m. It is also available in foil.

5.4.5 Synthetic Zeolites

Three zeolites called Linde molecular sieves have been investigated for use as getters. These are type 4A, Type 4A-30, and Type 5A. Since they are similar they will be considered in one group. Type 4A-30 has a clay which is added to Type 4A as a binder and increases its capacity by about 15%. 4A differs from 5A in that it has a sodium cation while 5A has a calcium cation. The chemical formula for Type 4A is:

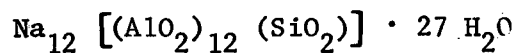

and for Type 5A

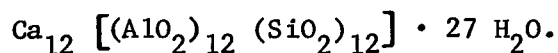

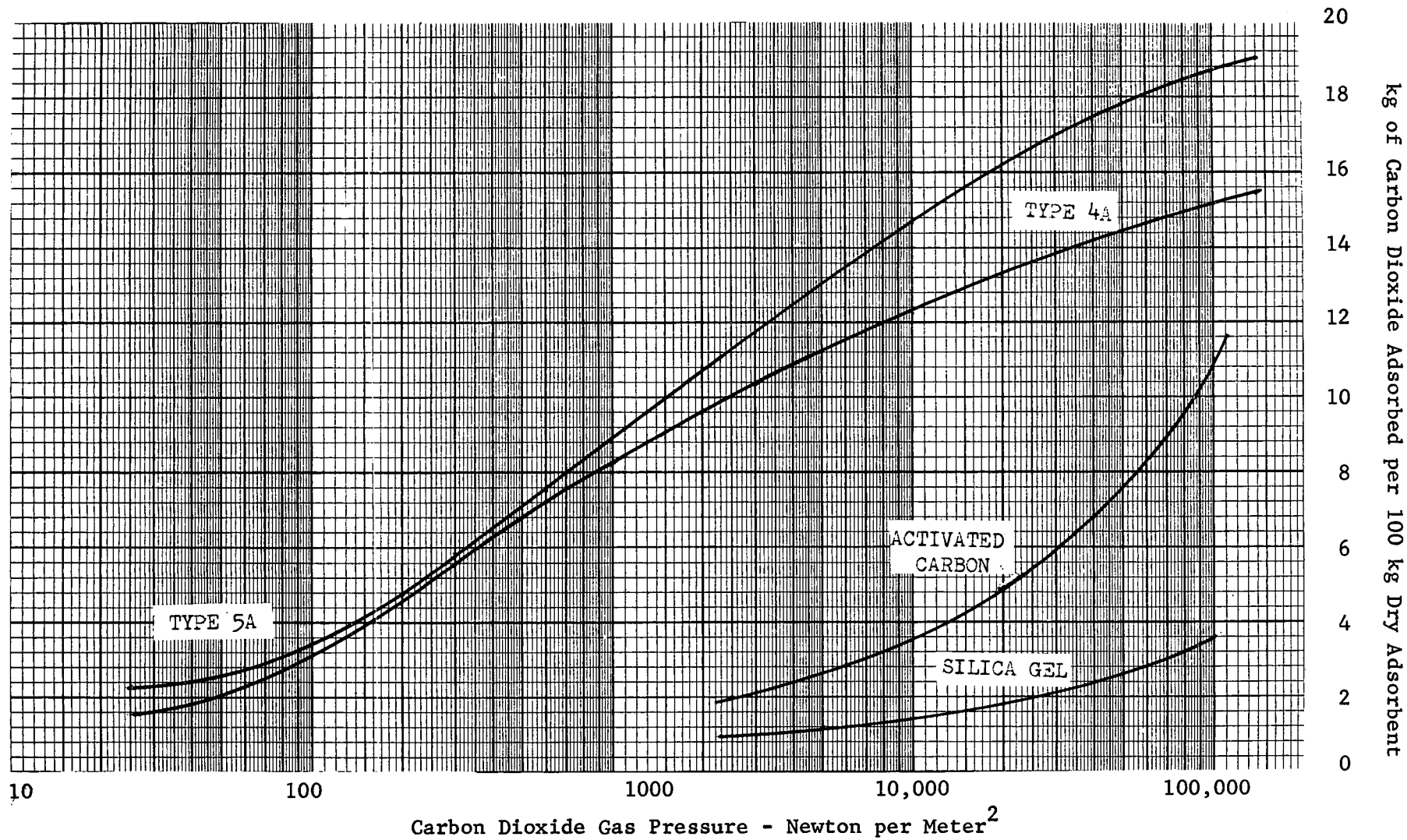

Figure 5.3 Carbon Dioxide Adsorption Characteristics in Several Adsorbing Materials

In the process of formation water is removed which providing large molecular cavities in the inner structure. Pores of about 0.4 nm in diameter in Type 4A and 0.5 nm in diameter for Type 5A are passageways for molecules to enter the inner cavity where the entrapped molecules remain.

a) Capacity/Mass

The capacity per unit mass of getter⁽¹⁰⁾ is shown in Figure 5.3 for Type 4A and Type 5A at 298 K. These curves are obtained by first baking out the molecular sieve to 525 K while evacuating the molecular sieve by pumping on them with a vacuum pump. The sieves fill the container which contains them. Figure 5.4 shows the N_2 capacity per unit mass of Type 5A at 293 K and 77 K⁽¹¹⁾.

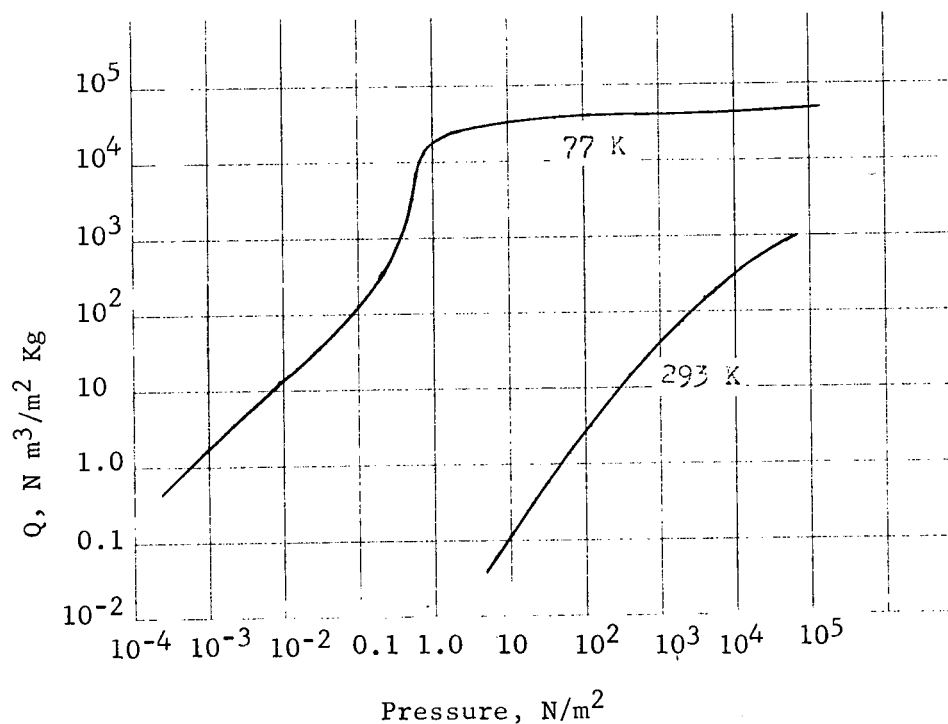

Figure 5.4 - Adsorption Isotherms. Nitrogen on Molecular Sieve 5A.

The 77 K curve is shown to point out the large difference in capacity when cold from that at 293 K. The capacity of this pump at 340 K is unknown but needed if the pump is used in the probe and the probe temperature is not controlled. If the maximum pressure allowable within the pump is 133 N/m^2 or (1 torr), then the capacity is 515 Newton meters of CO_2 per kilogram of adsorbent (3.88 torr liter of CO_2 per gram of adsorbent).

Type 4A has slightly less capacity. At the same pressure the capacity for N_2 in Type 5A is 6.65 N/m per kg (5×10^{-2} torr liter/g). No information is available for the nitrogen capacity of Type 4A. At pressures below 133 N/m^2 , the capacity for all gases is greatly reduced and unknown below a pressure 13.3 N/m^2 . At 77 K, Argon is adsorbed in these sieves, however, no information is available for the adsorption for Argon at higher temperatures.

b) Pumping Speeds

The pumping speeds for all gases are unknown for these sieves.

c) Specificity

No information is available at 293 K about the selectivity of these sieves when a mixture of gas is used.

d) Operating Temperature

A little information is available at 300 K but no known information is available at higher temperature. Adsorption characteristics are needed for temperatures as high as 350 K which is the approximate

maximum temperature inside the Pioneer Venus probe.

e) Operating Pressure

The capacity is greatly reduced at lower pressures. Below 26.6 N/m^2 no information is available for the sorption of CO_2 . These materials may be useful in a atmospheric pressure reduction system where the useful pressure may be about 133 N/m^2 or (1 torr).

f) Configuration

Zeolite comes in granular form or pellet form. The enclosure is designed to fit the application.

g) Source

Synthetic zeolites are manufactured by the Linde Division of Union Carbide Corporation with Corporate offices at 270 Park Avenue, New York, New York 10017. Sales offices are in major cities throughout the United States.

h) Activation

These sieves are activated by baking for at least 24 hours at 550 K while being evacuated by a chamber that has an ultimate pressure below 10^{-4} N/m^2 . By this method the initial pressure of the sieve is in the 10^{-3} N/m^2 region.

5.5 Conclusions and Recommendations

Each type of getter has some interesting and useful applications but some are recommended over others. A summary of the materials is stated below.

5.5.1 ST-101 Zirconium Aluminum

Zirconium aluminum is adequate for all three pumping applications; the noble gas pump, atmospheric pressure reduction, and vacuum maintenance pump. Certain restrictions, however, do apply. For the noble

gas pump it must be operated at a temperature of 675 K and the maximum pressure in the pump below 1.33 N/m^2 . In the pressure reduction pump, the getter can only pump 99.99% of the gas. No noble gases are pumped. The pump pressure needs to be maintained at less than 1.33 N/m^2 (10^{-2} torr) or its capacity will be reduced. In the vacuum maintenance pump, which probably cannot be operated heated because of the large amount of energy required over the period involved, the zirconium aluminum has some capacity for hydrogen at 295 K and a smaller capacity for N_2 . A 10^{-4} m^2 surface of this getter can adsorb $1.3 \times 10^{-3} (\text{N/m}^2) \text{ m}^3$ (.1 torr liter/cm²) of hydrogen. On a surface of the same size $6.6 \times 10^{-6} (\text{N/m}^2) \text{ m}^3$ or (5×10^{-4} torr liter/cm²) of nitrogen can be pumped. ST101 zirconium aluminum⁽¹⁰⁾ is available in several forms: sheets, rings, and large pumps. Configurations are presently available for the above applications. Only a minimum design effort would be required for pump configuration and operation.

5.5.2 ST-171 Zirconium Graphite

Zirconium graphite has interesting possibilities for vacuum maintenance. It has a larger capacity than ST-101 for active gases other than hydrogen at 298 K. The speeds for hydrogen are comparable.

5.5.3 Ceralloy 400

This getter has good pumping capabilities. Speeds and capacities are similar to zirconium aluminum when operated at 675 K. The capacity for CO_2 is about 30% greater than it is for zirconium aluminum. However, information on this material was developed in the early

1960's and some of the information was in question then. An experimental evaluation of the material is in order. Presently, the only useful form is in small coated metallic strips. Considerable amount of development and design time is required to produce a useful pump. This could be an alternate to the SAES materials.

5.5.4 Zirconium Titanium

Much of the required information about zirconium titanium is unavailable. It has a known capacity for O_2 at 650 K and is used for removing the active gases from noble gas environments. It is available in chips and in foil. An experimental evaluation would be necessary before it could be recommended.

5.5.5 Synthetic Zeolites or Linde Molecular Sieves

Three forms of Linde molecular sieves appear to be potentially useful: Type 4A, Type 4A-30, and Type 5A. These sieves have possible applications in a pump to reduce the atmospheric pressure, if the final pressure can be as high as 133 N/m^2 . There are several unknown characteristics of these sieves. No pumping speed information is available and just a limited amount about the capacity. No information on Type 4A as to the amount of nitrogen it will adsorb is available. No information about pumping capacity at temperatures above 298 K. This material needs to be kept cool and so must remain inside the space vehicle capsule but has the possibility of being subjected to 350 K temperatures. This information is needed. The attractive feature is that it has a large gettering capacity for CO_2 at a pressure of 133 N/m^2 and 295 K. Its capacity increases with pressure. Where a final

pressure of at least 133 N/m^2 is satisfactory these sieves are candidates. Experimental evaluation is needed to determine more about their operating characteristics.

5.6 Follow-On Material Evaluation Studies

On a basis of the information available concerning them three of the materials discussed in this section appear to have potential use for the Pioneer Venus program but cannot be evaluated fully without more data. These three materials are:

- (1) Cer Alloy 400
- (2) Zirconium Titanium (87.5% - 12.5%)
- (3) Linde Molecular Sieves, Types 4A and 5A

Brief descriptions of the recommended programs of investigation are presented below.

Cer Alloy 400

A sample of at least 0.1 meter² of Cer Alloy 400 is to be installed in a pump enclosure. This enclosure is to be designed with the heating capability to bring the material to its operating temperature. Since the material cannot be reactivated the enclosure must permit replacement of the pumping material. The test program of this material should determine the pumping capacities, the speed, maximum operating pressure, the gas selectivity and a practical operating temperature. The residual gas background will be monitored. Pumping characteristics should be measured over a range from 10^{-4} to 10^2 Newton/(meter)². The investigation would consist of design and fabrication of a pump housing, setup and operation of the tests, analysis and reporting of results.

Zirconium Titanium

The program for this material is essentially the same as for Cer Alloy 400. While the two materials are available in different forms it is reasonable to design a heatable container which is suitable to both.

Linde Molecular Sieves, Types 4A and 5A

These materials are primarily attractive for lower temperature (~300 K) and moderate pressure (1.0 to 100 Newton/(meter)²) applications such as a general pressure reduction. These materials

should have pumping capacity and speed determined for CO_2 , N_2 , Ar and perhaps other potential constituents of the Venus atmosphere. The measurements should be made over a range of temperatures which coincides with anticipated large probe internal temperatures, roughly 270 K to 350 K.

6. TESTING OF SAES ST-101 PUMPS

One type of getter of particular interest is a zirconium aluminum material marketed by SAES Getters S.p.A of Milan, Italy. This material, available in a variety of pump configurations, is called ST-101 by the manufacturer. It has large speed to mass and capacity to mass ratios for active gases and does not pump noble gases. These properties make it an attractive candidate for the noble gas analysis portion of the Pioneer Venus Mass Spectrometer Experiment. Data available from the manufacturer does not describe the capability of ST-101 for pumping carbon dioxide nor does it give information for pumping at pressures in the 0.1 to 1.0 Newton/(meter)² range. For these reasons the performance of two pumps has been investigated in this program. The SAES designation for the tested cartridge model is C-200. The C-200 cartridge occupies a cylinder 6.15 x 10⁻² meter in diameter and 9.3 x 10⁻² meter in length and has a mass of .645 Kilogram. A central cylindrical volume 3.4 x 10⁻² meter in diameter is empty space left for the radiant electrical heater used in activating the pump.

6.1 Method of Testing

The basic approach used here to measure the pumping speed is to introduce gas through a calibrated leak into a chamber of known volume and measure the pressure in the chamber with the pump functioning (See Figure 6.1).

Once valve v_1 is opened the pressure in the test chamber is described by;

$$V \frac{dP}{dt} = P_0 F - PS \quad (6.1)$$

The assumption is made here that the source pressure, P_0 , is considerably higher than the pressure, P , in the test chamber.

When valve v_2 is closed the pressure in the test chamber is governed by

$$V \frac{dP}{dt} = -PS \quad (6.2)$$

If the chamber pressure is initially zero, then the pressure history implied by these equations is

$$P(t) = \left\{ \begin{array}{ll} 0 & , t < 0 \\ P_o \frac{F}{S} \left(1 - \exp \frac{-st}{V} \right) & , 0 \leq t \leq T \\ P_o \frac{F}{S} \exp \frac{-s(t-T)}{V} & , T \leq t \end{array} \right\} \quad (6.3)$$

This function is illustrated in Figure 6.2. The expression for the period $t \geq T$ is an approximate one based on the assumption that an equilibrium pressure is achieved between the opening of v_1 and the closing of v_2 . This requires that gas flow into the chamber for a time long in comparison with V/S (i.e., $T \gg V/S$). This criterion met, the pressure in the chamber just prior to closing v_2 is simply related to the pumping speed by

$$P(T) \approx P_o \frac{F}{S} \quad \text{or} \quad S = \frac{P_o}{P(T)} F \quad (6.4)$$

It is this equation which is used to determine pumping speed. The quantity of gas, Q , which is pumped in a single test cycle as shown in Figure 6.2 is given by

$$Q = \int_0^{\infty} P(t)S dt \quad (6.5)$$

$$Q = P_o FT \quad (6.6)$$

From an examination of equations (6.1) and (6.2) it is clear that, in principle, a careful measurement of the internal chamber pressure as a function of time would permit determination of pumping speed at all pressures from zero to the equilibrium pressure. We were unable to obtain sufficiently good data on the time derivative of test chamber pressure to obtain satisfactory values for pumping

speed in this transient fashion. All of our speed measurements were made under equilibrium conditions*.

As used here the term capacity of a pump means the total amount of gas pumped prior to the pumping speed going to zero.

6.2 Test Setup

Of necessity the actual test setup was considerably more complicated than indicated in Figure 6.1. The actual configuration is shown in Figure 6.3.

Valves v_2 and v_5 were fast toggle valves. The pressure gauge G_1 was a Wallace and Tiernan Bourdon tube gauge with a full scale range of 1.06×10^5 Newton/(meter)². The internal space of this instrument served as the gas source volume. Gauge G_3 was a Baratron Differential Capacitance Manometer with a range on three scales of 1.3×10^{-3} Newton/(meter)² to 40 Newton/(meter)². The output of the differential manometer was recorded on a CEC recording oscillograph. The gas composition in the system was monitored with a Spectroscan 750 Quadrupole Mass Spectrometer.

Two volumes were important to the tests, the source volume which consisted of the Wallace and Tiernan gauge and the space between valves, v_1 and v_2 , and the test volume including the plumbing terminated at the calibrated leak, at v_3 , v_4 , v_6 , v_{10} and the high pressure side of the capacitance manometer. These volumes were calibrated by expanding gas from a known volume, consisting of a calibrated tank and a small amount of carefully measured connecting tubing, into the unknown volumes.

In the initial tests the calibrated leak was a micrometer adjusted metering valve. This valve had a Kel-F seat which appeared to be affected by exposure to carbon dioxide. Consequently the

*In some "high" pressure pumping tests true equilibrium was not achieved and dP/dt corrections were made to speeds calculated from Equation (6.4).

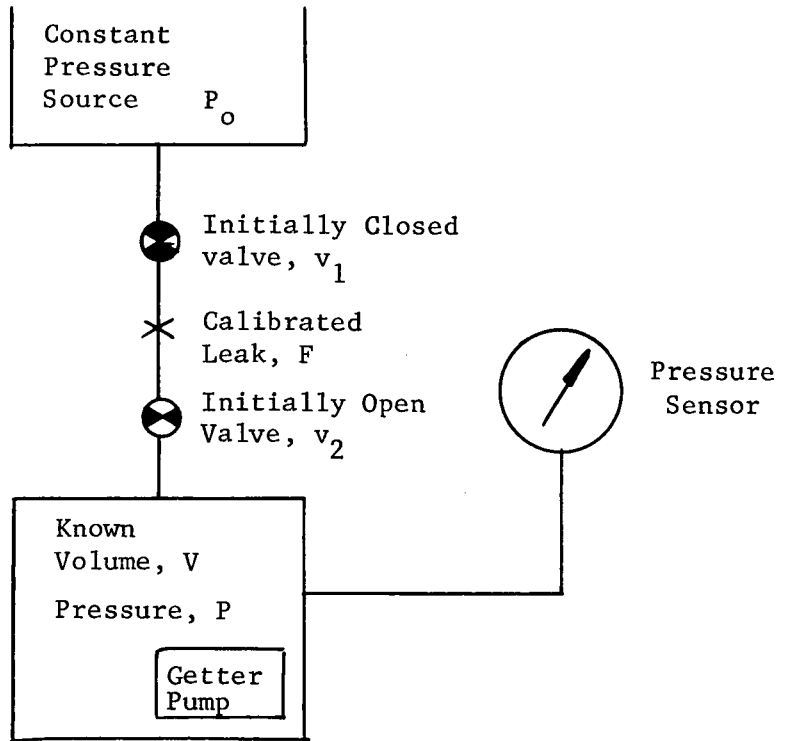

Figure 6.1 Schematic of Pump Speed Test

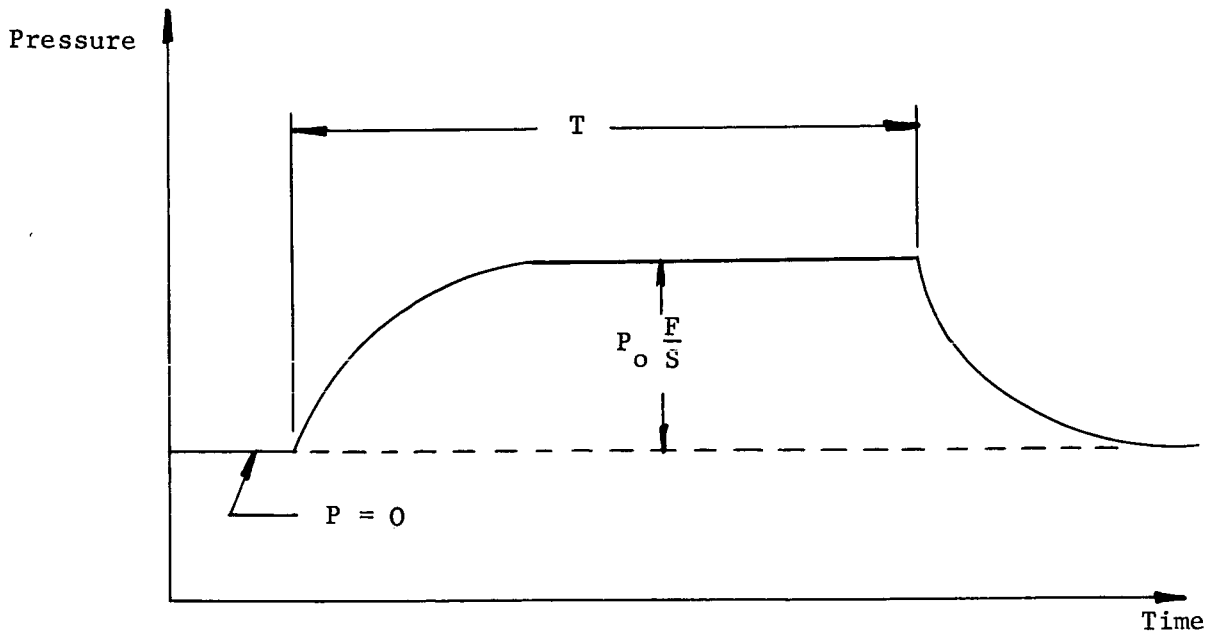

Figure 6.2 Test Chamber Pressure Profile

47

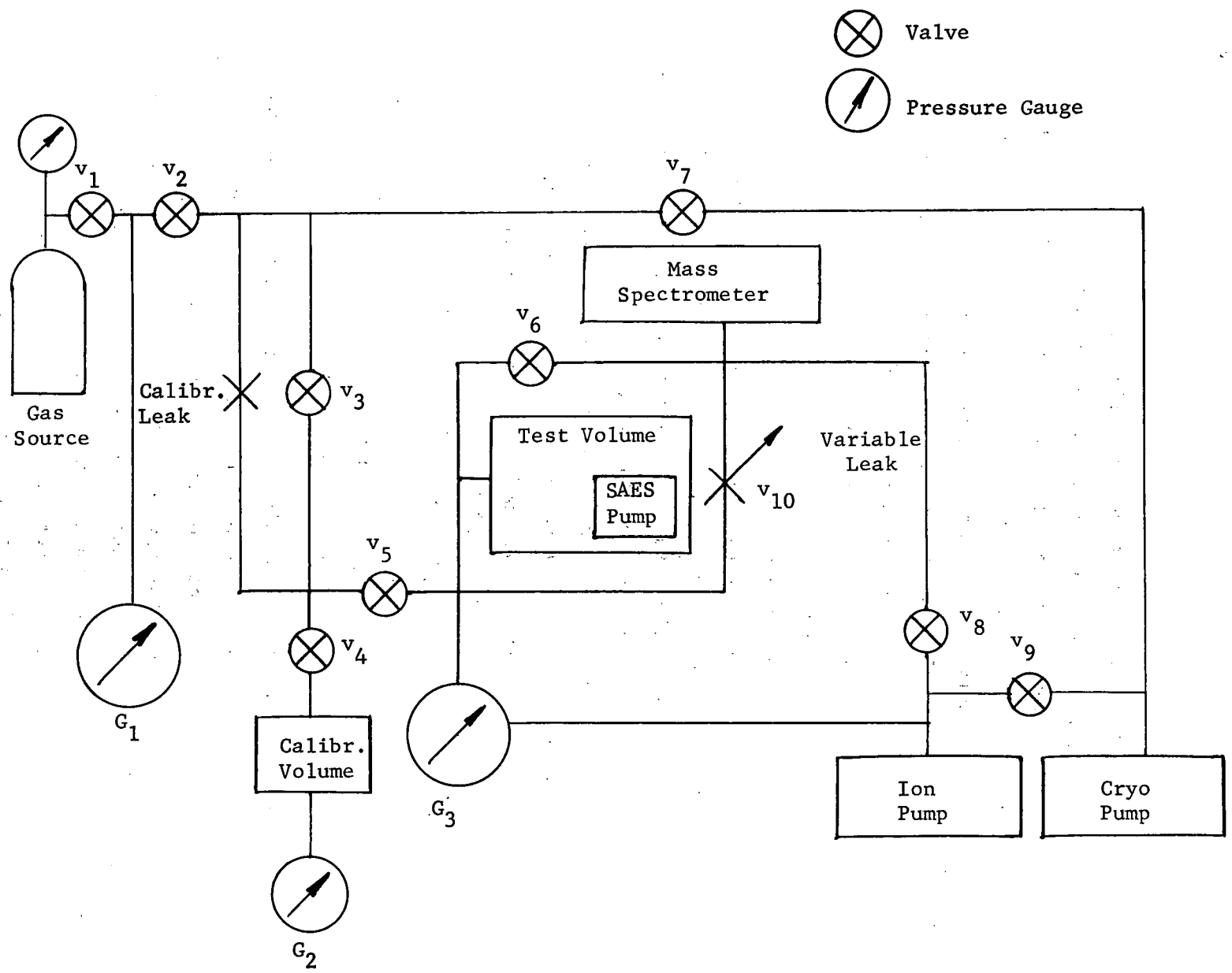

Figure 6.3 Experiment Test Configuration

calibration of the leak changed over a period of time. When this lack of stability of the leak conductance was noted a replacement leak was made of copper tubing. The tubing was crimped until the flow conductance was in the desired range. The conductance was determined by measuring the pressure in the calibration volume (see Figure 6.3) as that volume was filled from a constant pressure source through the leak being calibrated. The results of this calibration are shown in Figure 6.4.

6.3 Test Conditions

In measuring the pumping speed of the SAES pump, carbon dioxide was used as the test gas because of the predominance of this gas in the Venus atmosphere. Small leaks which existed in the system resulted in the actual test gas consisting of carbon dioxide with an admixture of air. The size of the leak was calculated from the rate of rise of argon pressure, measured during tests of the second pump, in the test volume. The combined gas introduced into the test volume had the following relative composition:

CO ₂ :	.996
N ₂ :	2.5 x 10 ⁻³
O ₂ :	7 x 10 ⁻⁴
Ar:	3 x 10 ⁻⁵

Table 6.1 Fractional Abundances in Test Gas

This table is an accurate composition of the test gas only for the capacity test of the second pump. It is simply to be considered representative of the composition for the other tests.

The two pump cartridges used in this test were both C-200 models. They were, however, subjected to different activation procedures due to differing instructions received with the two cartridges. The first pump was activated by running 3.9 amperes through its heater for 30 minutes. The second was activated with 4.7 amperes for fifteen minutes.

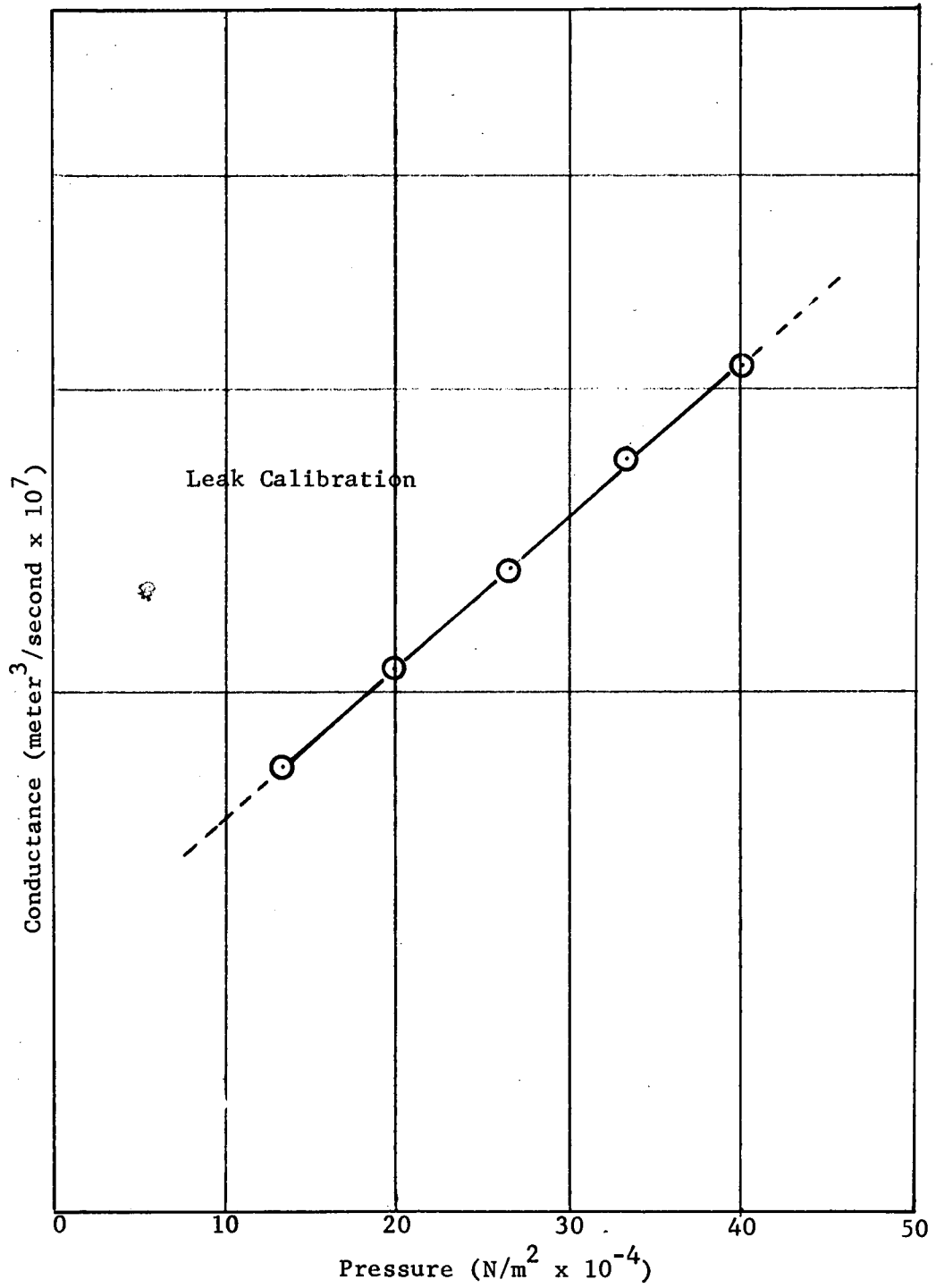

Figure 6.4 Leak Calibration

Data available from SAES gives pumping characteristics of C-200 cartridges for carbon monoxide, hydrogen and nitrogen in the pressure range of 10^{-4} Newton/(meter)². The requirements of the Pioneer Venus noble gas experiment are for the pumping of a gas which is mostly carbon dioxide and is at higher pressures. The measurements made in this study were performed at test volume pressures in the range 0.4 to 10 Newton/(meter)². Measurements were made with nitrogen as well as carbon dioxide to provide a partial basis for extrapolation of CO₂ parameters to lower pressures in the range of the manufacturer's nitrogen data.

The pumps were operated, according to manufacturer's directions, with heater currents of 1.9 and 2.2 amperes. These currents nominally produce a pump temperature of 670 K. The different currents arise from the differences in the two sets of instructions mentioned previously.

Prior to introduction of the test gas, pressure in the test volume was reduced to less than 10^{-6} Newton/(meter)² with the ion pump. This pressure was measured with an ion gauge. The test volume was then isolated from the ion pump. During the test runs the pressure in the test volume was measured with the differential capacitance gauge which had a least count on its digital output of 1.33×10^{-3} Newton/(meter)².

6.4 Results

The first pump tested, the one activated at 3.9 amperes, was put through a series of speed test runs at increasing pressure, then reactivated and tested again. The results of these test runs are presented in Table 6.2 in the order in which they were performed. All the measurements leading to the data in Table 6.2 were made with CO₂ with a small admixture of air.

Run	Activation	Pressure	Speed
		$\frac{\text{Newton}}{(\text{meters})^2}$	$\frac{(\text{meter})^3}{\text{second}}$
1	1	.182	1.14×10^{-2}
2	1	.524	1.25×10^{-2}
3	1	.539	1.19×10^{-2}
4	1	1.23	1.29×10^{-2}
5	1	>1.47	1.66×10^{-2}
6	1	>>1.47	--
7	1	1.78	1.38×10^{-2}
8	2	.197	1.09×10^{-2}
9	2	.558	1.15×10^{-2}
10	2	1.37	1.19×10^{-2}

Table 6.2

Speed Measurements with First Pump (SAES ST-101, C-200)

The pressure gauge outputs are limited on runs 5 and 6. On run 5 the limiting appeared to be slight and thus an upper bound on the pumping speed is presented in the Table.

The micrometer valve, used as a inlet leak during the tests of the first pump, was calibrated before and after the series of test runs. The conductance decreased during this period by a factor of approximately 2. The speed values in Table 6.2 were calculated using the larger conductance value.

The change in conductance of the inlet leak makes it unwise to draw any strong conclusions from the data in Table 6.2. One can only say with certainty that the speed of the pump was of the order of $10^{-2}(\text{meter})^3/\text{second}$. The dependence on pressure in

the range of measurement is apparently slight, as is the change from first to second activation.

The second pump was tested first for speed with CO₂ and then N₂ at pressures of about 0.4 Newton/(meter)². Next the capacity of the pump for CO₂ was determined by a series of speed measurements between a constant gas flow was introduced into the test chamber. The pump was then reactivated and its speed for CO₂ at about 0.4 Newton/(meter)² was measured. The pump capacity was then measured at a higher flow rate than before. After another activation this most recent capacity determination was repeated. For tests of the second pump the micrometer leak was replaced with the copper tube leak. These measurements are discussed in the following paragraphs.

After the initial activation of the second pump its speed for CO₂ and N₂ were measured. The data from these measurements are presented in Table 6.3.

Test Gas	Pressure $\frac{\text{Newton}}{(\text{Meter})^2}$	Speed $\frac{(\text{meter})^3}{\text{second}}$
CO ₂	.463	0.520 x 10 ⁻²
N ₂	.432	0.556 x 10 ⁻²

Table 6.3
Speed Measurements, Second Pump, First Activation

The amount of gas pumped during these two speed determinations was less than 10⁻³ Newton/meter (10⁻² torr liter). This is four decades less than the nominal pump capacity.

The capacity measurement made subsequently was performed by maintaining a fixed flow rate into the test volume and periodically measuring the pumping speed. The total amount of gas pumped

when the pumping speed goes to zero is the pumping capacity. This measurement required an extended period during which noble gases admitted to the test volume through leaks in the system built up a significant pressure. In order to determine the pumping speed for active gases it was necessary to subtract this noble gas partial pressure from the measured chamber pressure. This pressure was measured by briefly shutting off the CO₂ flow (valve v₂ in Figure 6.3) at the time of each speed measurement. When this was done the active gas partial pressure, no longer determined by an equilibrium between CO₂ influx and getter pump speed, dropped abruptly. The residual gas was the noble gas which had leaked into the system. That this was the case was verified by monitoring the gas in the test volume with a mass spectrometer.

It should be pointed out that the pumping capacity, determined by this method, is not determined at a constant pressure. Instead the test volume pressure increases as the pumping speed decreases. The measurements are presented in Figure 6.5. Speed measurements were made over a test volume pressure range of 0.45 to 2.05 Newton/(meter)². The capacity, determined by extrapolating the data to zero pumping speed, is 28 Newton meter (210 torr liter).

After the pump had been reactivated its speed in pumping CO₂ was measured at an operating pressure of .473 Newton/(meter)². The measured speed .508 x 10⁻² (meter)³/second reproduces the value determined after the initial activation to within experimental error.

The final tests performed on the second pump were intended to determine the pumping characteristics at higher operating pressures. The approach was the same as used previously, to introduce gas into the test volume at a fixed rate and determine pumping speed as a function of amount of gas pumped by following the pressure rise in the test volume. The operating pressure range for these

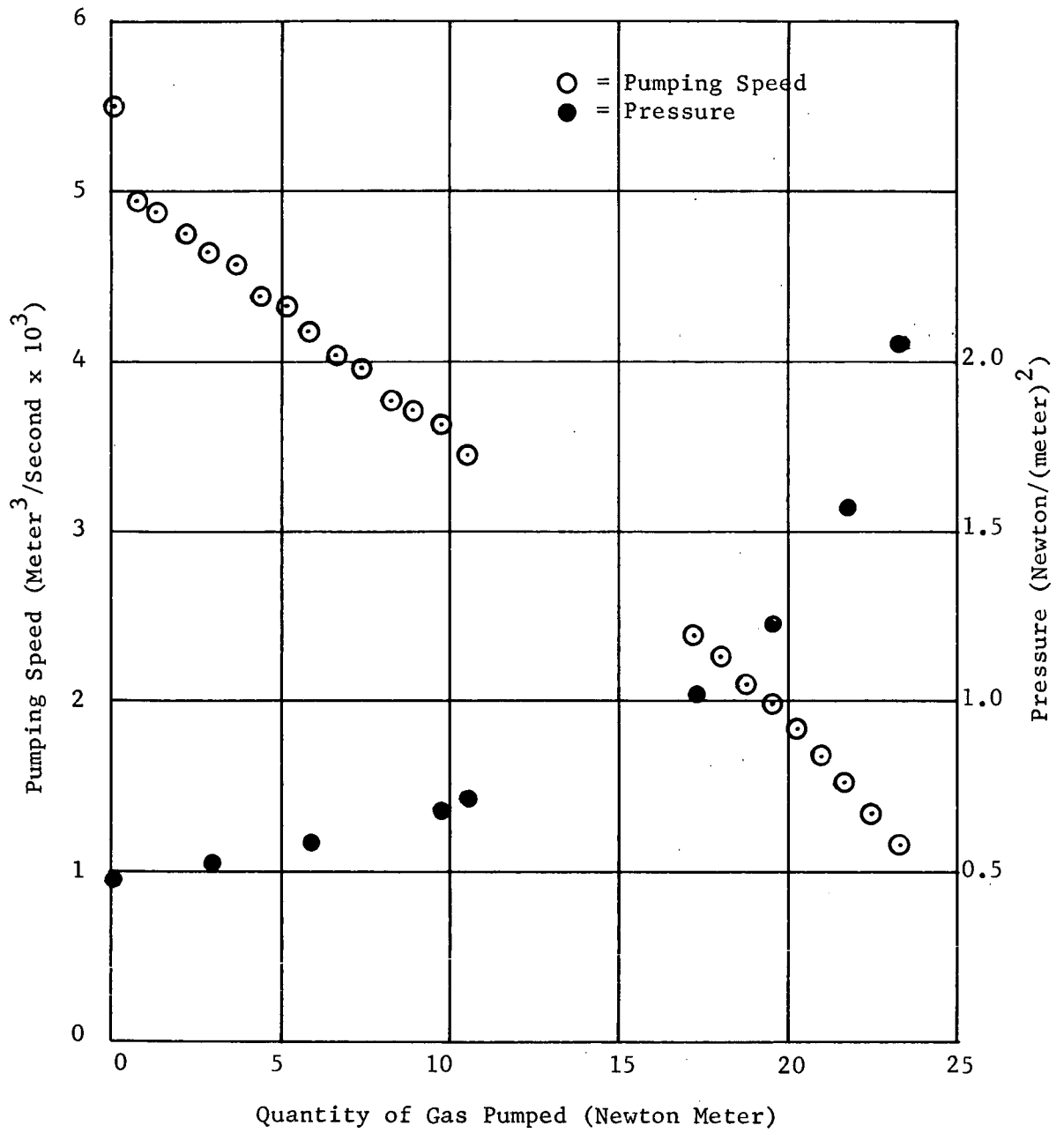

Figure 6.5 Pump Capacity Test

measurements was from 2.32 Newton/(meter)² to over 12 Newton/(meter)².

Data taken after the third activation of this pump are presented in Figure 6.6. For the data taken at the lower pumping speeds, Equation (6.4) is no longer adequate for computing speed from the pressure data. When the rate of change of pressure in the test volume is significant compared to the flow through the calibrated leak divided by the volume of the test chamber a correction must be made to the computed pumping speed. The correction Δs to Equation (6.4) is given by

$$s = - \frac{V}{P} \frac{dP}{dt} \quad (6.7)$$

The correction has been made to the data shown in Figure 6.6. The pumping capacity, obtained as before by extrapolating to zero pumping speed, is approximately 3.4 Newton meters. This value is an order of magnitude smaller than both the capacity measured at pressures around 1 Newton/(meter)² and that quoted by the manufacturer at approximately 10⁻⁴ Newton/(meter)². It appears that there is a critical pressure somewhere around 1 Newton/(meter)² at which the pump is swamped and exhibits diminished capacity.

An important feature of the ST-101 pump, which distinguishes it from the zeolites as an example, is that a saturated pump can be exposed to a lower pressure than it can maintain by itself without behaving as a source of gas. This sort of behavior is particularly important for a material which is used in a vacuum maintenance application, holding pressures at a moderate level until another pump, which will produce a lower pressure, is started.

An important feature of the ST-101 pump when considered for the noble gas experiment is its capability to pump active but not noble gases. This capability is exhibited in Figure 6.7. Figure 6.7 is a series of mass spectrometer traces of the residual gas in the test volume with the pump operating. The partial

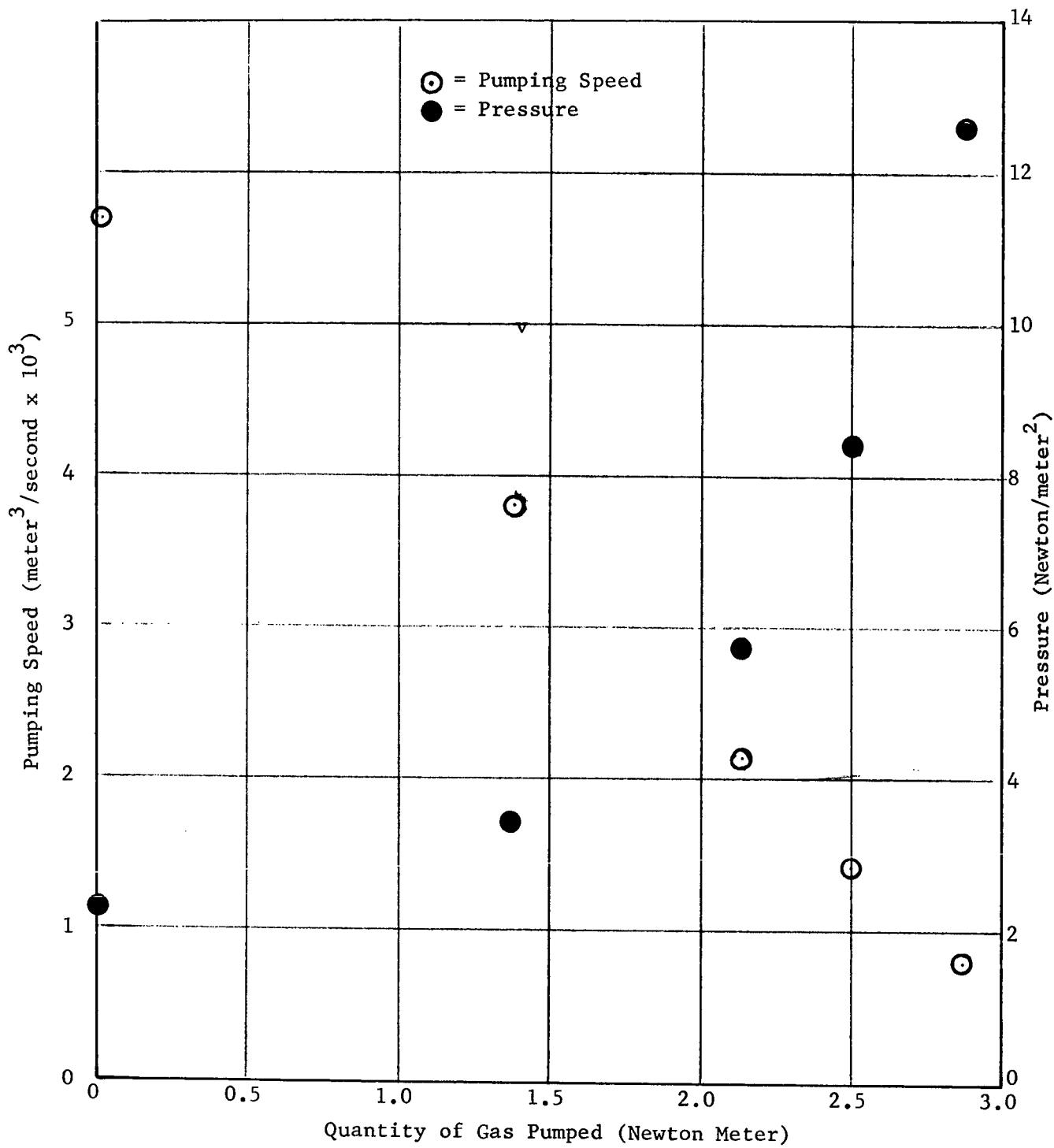

Figure 6.6 Pump Capacity Test - Second Pump

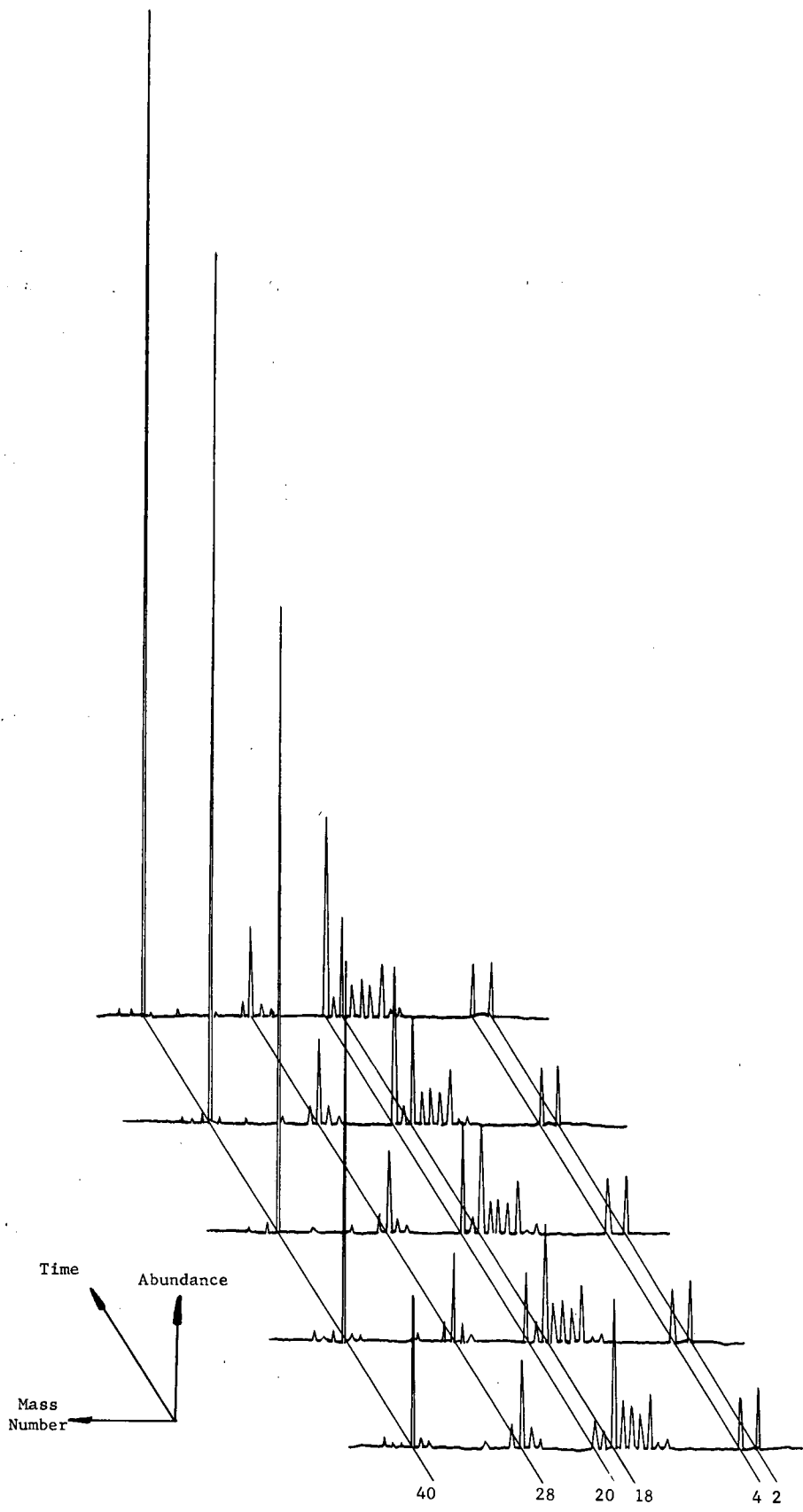

Figure 6.7 Noble Gas Growth in Getter Pumped Volume

pressures of the active gases being introduced into the chamber through system leaks and by outgassing are in equilibrium with the pumping rate of the ST-101 pump. The noble gas partial pressures (note masses 20 and 40) rise linearly with time as one expects with a constant rate of introduction and a negligible pumping rate. Helium at mass number 4 is neither being introduced in significant amounts through the air leak nor being pumped by the SAES pump. These spectra were taken during the setup for the first capacity determination for the second pump. The test volume had been pumped down to approximately 10^{-6} Newton/(meter)² with the ion pump and then isolated from the ion pump slightly before the time the first trace was made.

The most important results of these tests can be summarized in the following statements.

- (1) An ST-101, C-200 pump operating in pressures of the order of 1 Newton/(meter)² will pump CO₂ at 5×10^{-3} (meter)³/second. This is approximately 8×10^{-3} (meter)³/second per kilogram of pump, including mechanical support for the pumping material but not an exterior housing or activation heater.
- (2) An ST-101, C-200 pump has a capacity for CO₂ of approximately 28 Newton meter (210 torr liter) when operated at pressures less than 1 Newton/(meter)², approximately 43 Newton meter per kilogram of pump.
- (3) The pumping rate of ST-101 for noble gases is negligible when compared to the rate for active gases (if not actually zero).

7. PUMP DESIGN

In the survey of getter pump materials we have identified potentially useful getters for all three applications considered: the noble gas experiment, vacuum maintenance and overall pressure reduction. In this section we will discuss a preliminary design of a pump to be used in the noble gas experiment. Specific design of a pump for either of the other two applications is considered inappropriate. Vacuum maintenance over periods of 10^7 seconds with moderate leak and outgassing rates can be accomplished with commercially available elements (e.g., SAES Getters S.p.a. Type ST-171) weighing of the order of 10^{-2} kilogram and operating at temperatures of 300 K and up. Such an element could be installed during instrument manufacture and then activated electrically after the instrument is sealed. The detailed requirements for atmospheric pressure reduction are strongly dependent on the choice of inlet system and the dynamic range of the mass spectrometer. As an extreme example it is possible to obtain sufficient pressure reduction without using a pump for that purpose in a multiple inlet system. At the other extreme the system described in Section 4.2 could be used with an instrument having a dynamic range of N decades in an experiment designed to detect species present in abundances of 1 part in 10^N . In this case a pump such as will be described here for the noble gas experiment and differing only slightly in size could be used. It should be noted that in such a system the pump itself is not the critical item. The controllable variable valve is.

7.1 Design constraints

The pump, for the noble gas experiment, which is described in this Section was designed on a basis of the constraints developed in Section 4.1, the experiments reported in Section 6, and further analysis to be described here. Particular attention

was paid to configuration and power requirements for a realistic Pioneer Venus large descent probe. The pump uses SAES ST-101 getter material and is located outside the descent probe insulation where the hot atmosphere can be used to achieve the nominal 670 K operating temperature for the pump elements.

For convenience the constraints on the noble gas inlet system of Section 4.1 are repeated here. The constraint arising from a requirement for enrichment of the noble component of the gas is

$$f \geq \frac{P_v^{(A)}}{P_v^{(N)}} \frac{V}{ST_1} e^{-\frac{ST_2}{v}} \quad (7.1)$$

The constraint arising from the requirement that the enriched noble gas sample be depleted by no more than a prescribed fraction during the analysis interval is

$$\epsilon \geq \frac{F_1 T_3}{v} \quad (7.2)$$

The constraint arising from the requirement that a maximum ion source pressure not be exceeded is

$$P_{\max} \geq P_v^{(N)} \frac{F_o}{v} \frac{F_1}{S_T} T_1 \quad (7.3)$$

Finally the requirement that the pump have adequate capacity to accomplish the desired processing of the atmospheric sample is

$$C > P_v^{(A)} F_o T_1 \quad (7.4)$$

In these relations:

$P_v^{(A)}$ and $P_v^{(N)}$ are the partial pressures of active and noble gases at the Venus altitude where the sample is ingested, V is the volume of the gas processing chamber,

S is the speed of the processing pump,
 T₁ is the duration of the intake interval,
 T₂ is the duration of the interval between intake and scan,
 f is the maximum ratio of active gas pressure to noble gas pressure in the processed sample,
 ε is the maximum fractional loss in pressure of the processed gas sample during analysis,
 F₁ is the flow conductance between the processing volume and the ion source,
 T₃ is the duration of the analysis interval,
 P_{max} is the maximum operating pressure for the ion source,
 F₀ is the conductance of the system inlet leak,
 S_T is the flow speed through the ion source,
 and C is the processing pump capacity.

The following set of assumptions was made concerning the experiment:

- (a) The gas sample is ingested at an altitude of 6 kilometers. As will be seen, at this altitude the externally mounted pump can be expected to have achieved the nominal operating temperature, 670 K. At this altitude

$$P_v^{(A)} \approx 7 \times 10^6 \text{ Newton}/(\text{meter})^2$$

$$\text{and } P_v^{(N)} \approx 7 \times 10^2 \text{ Newton}/(\text{meter})^2 .$$

- (b) The ion source is pumped at $ST = 10^{-4} (\text{meter})^3/\text{second}$.
 (c) The maximum ion source pressure is $P_{\text{max}} = 10^{-4} \text{ Newton}/(\text{meter})^2$.
 (d) The fractional decrease in processed gas pressure during analysis is 0.2. This is adequate if the analysis includes at least a partial rescan.
 (e) The partial pressure of active gas in the processed sample is no greater than that of the noble gas.

(f) The analysis time is 10^2 seconds.

If we choose a pump with a speed of 7×10^{-3} (meter)³/second and a capacity of 10^2 Newton meters one can house such a pump using ST-101 pumping elements in a 5×10^{-4} (meter)³ volume. A configuration for such a pump is shown in Figure 7.2. With a system inlet leak conductance of 2×10^{-10} (meter)³/second, a conductance of 10^{-6} (meter)³/second between processing volume and ion source, an intake interval of 10 seconds, a processing interval after intake of at least one second, and this pump, the system constraints are satisfied as follows.

Enrichment:

$$f \geq \frac{P_v^{(A)}}{P_v^{(N)}} \frac{v}{ST_1} e^{-\frac{ST_2}{v}}$$

becomes $1 > 2 \times 10^{-5}$

Adequate enrichment is obtained easily with any reasonable time span between the end of the intake interval and the first introduction of gas into the analyzer.

Maximum Depletion of Processed Gas Pressure:

$$\epsilon \geq \frac{F_1 T_3}{v}$$

becomes $0.2 = 0.2$

Ion Source Pressure

$$P_{\max} \geq P_v^{(N)} \frac{F_0}{v} \frac{F_1}{ST} T_1$$

becomes 10^{-4} Newton/(meter)² $>$ 2.8×10^{-5} Newton/(meter)²

Capacity

$$C > P_v^{(A)} F_0 T_1$$

becomes 10^2 Newton meter $>$ 1.4×10^{-2} Newton meter

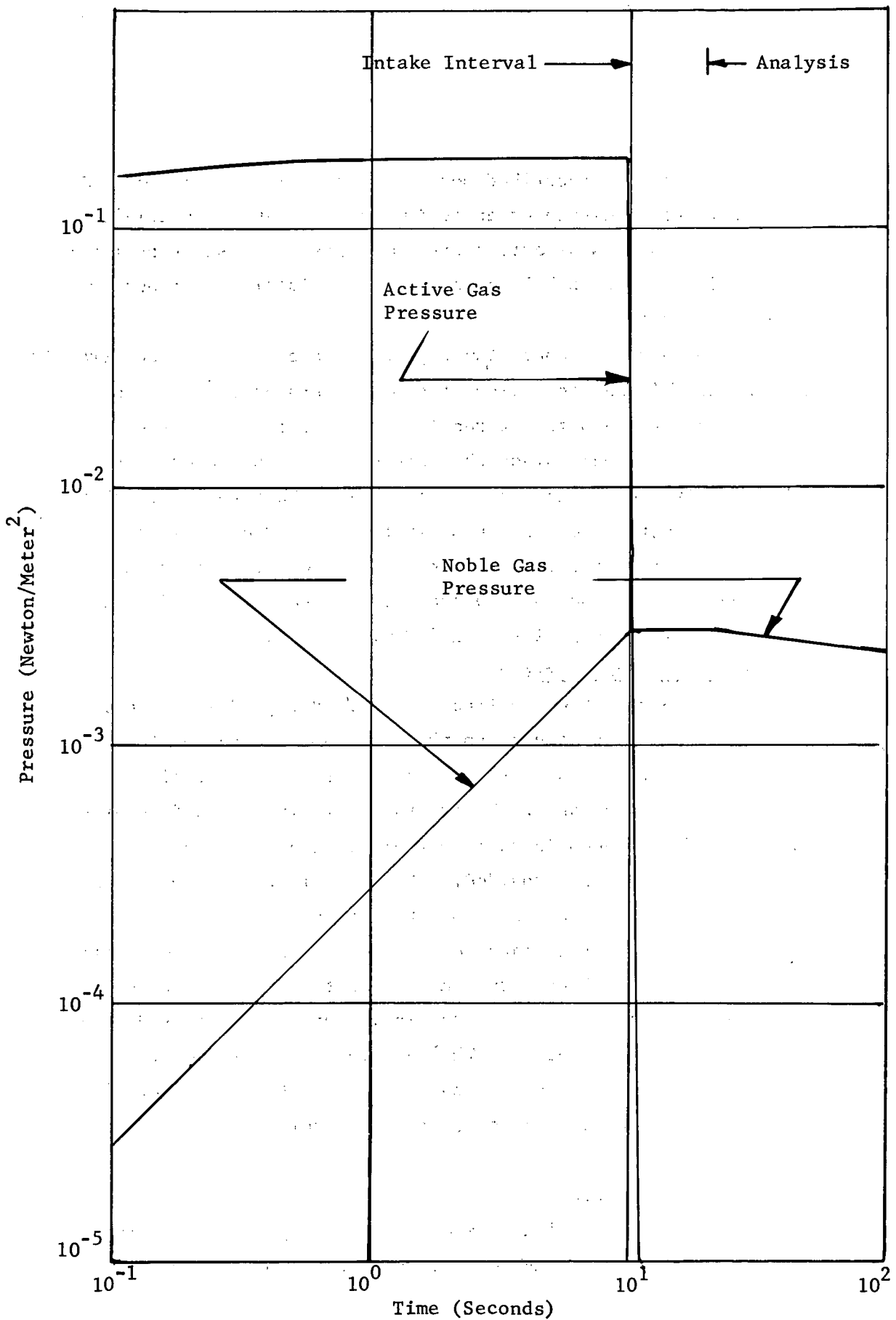

Figure 7.1 Processing Volume Pressures

The system described here operates with the ST-101 pump at an active gas pressure of approximately $0.2 \text{ Newton}/(\text{meter})^2$. The partial pressures of active and noble gases are shown as functions of time in Figure 7.1 for a ten second interval between intake and analysis.

The pump and conductance parameters satisfy the constraints with considerable margin. Since the parameters describing the instrument and the experiment requirements are to some extent arbitrary and, further, since the pump can be constructed with reasonable size and weight no attempt is made here to reduce that margin. With better definition of instrument and experiment one would probably reduce the margin in the interest of weight saving. For present purposes we shall proceed to design a $7.5 \times 10^{-3} (\text{meter})^3$ /second pump with a capacity of 10^2 Newton meter.

7.2 Design Configuration

The pump, shown in Figure 7.2, is designed in two cylindrical modules. This is done so that the pump can be mounted on the exterior of the probe with only minor effect on either the insulation configuration or the external aerodynamic configuration. Activation of this pump is to be performed in a vacuum oven. A pump evacuation line is provided. This line is welded shut after activation and before removal from the activation vacuum. The pump elements are in the standard SAES configuration, folded strips joined at the ends making a cylindrical part with a cylindrical open space along its axis. The ten individual elements used have a total mass of 0.8 kilogram. The canisters are designed to withstand the Venus surface environment. They are to be made of 321 stainless steel, selected because of its vacuum and welding properties.

7.3 Getter Heating

It is essential to the design of the pump that it make use of the atmosphere to achieve its operating temperature. A

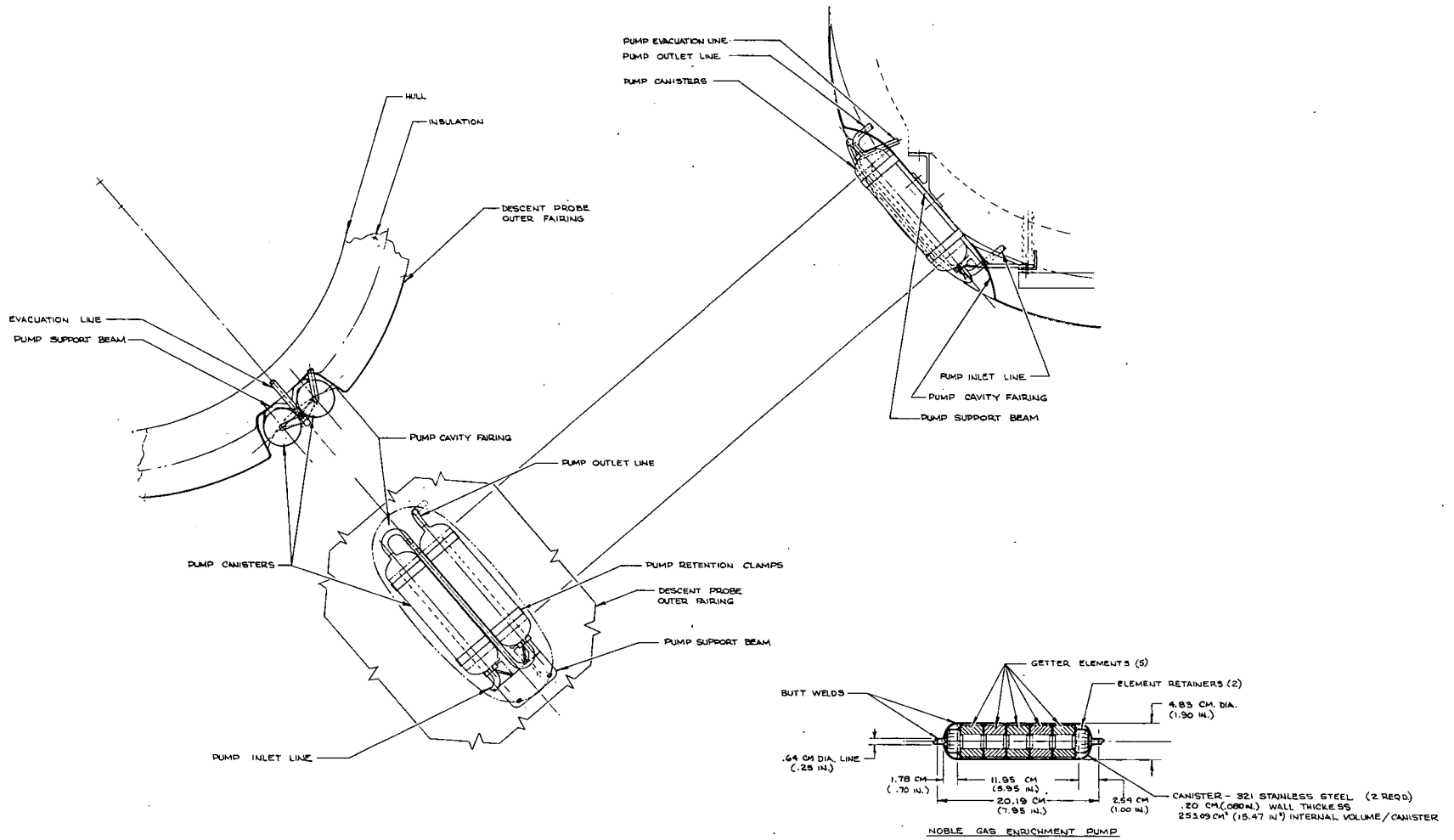

Figure 7.2 Noble Gas Experiment Pump Design

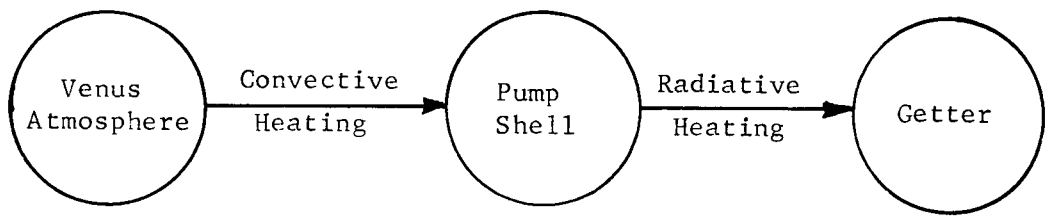

Figure 7.3

Network for Getter Temperature Analysis

quick calculation shows that to raise the temperature of the getter element from 300 K to 670 K in 3600 seconds would require a power input of approximately 50 watts. This amount of power is not available from the probe power system. Consequently the possibility of exterior mounting and atmospheric heating was investigated to this end.

A Mitas computer model was set up to evaluate the network shown in Figure 7.3. Heat transfer to the pressure shell of the pump was considered to be entirely convective and only radiative transfer from the shell to the getter was considered. The descent profile used was that of a current Martin Marietta large probe mission design. Heat transfer coefficients were calculated using data from Knudsen and Katz "Fluid Dynamics and Heat Transfer." The emissivity of the getter being unknown, the calculation was performed for two values of emissivity, 0.95 and 0.62. The emissivity of the shell was taken to be 0.7. The results of the computation are shown in Figure 7.4. This computation indicates that the getter will have reached its nominal operating temperature of 670 K when the probe is at an approximate altitude of 6 kilometers. It will have reached a lower limit operating temperature of 520 K at about 15 kilometers altitude. Thus a programmed operation at 6 kilometers would still be satisfactory even if the heating rate were somewhat below nominal.

7.4 Model Fabrication and Test

The pump described in this section is based on analytical models and pump data gained from testing of a somewhat different configuration. The next step in an orderly program of development of a noble gas enrichment system for the Pioneer Venus Mass Spectrometer System is to fabricate a laboratory model of the pump shown in Figure 7.2 . Tests with this model would serve to do the following:

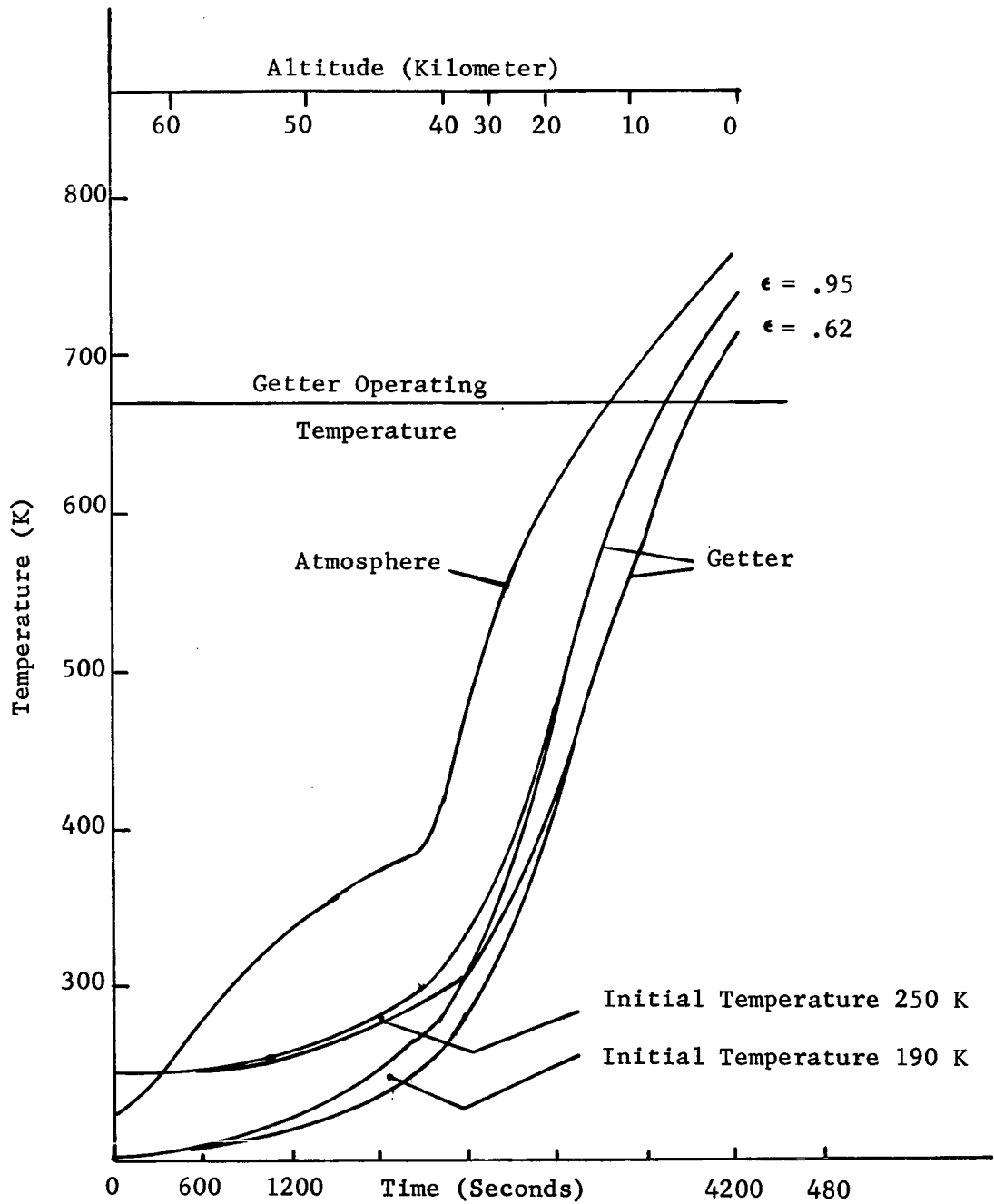

Figure 7.4 Atmospheric Getter Heating

- 1) Provide verification of the general approach to noble gas enrichment,
- 2) Establish effective techniques for activating the pump to include methods of heating and the temperature and the duration of the heating cycle,
- 3) Guide experimental optimization of such system parameters as flow conductances and time intervals,
- 4) Provide a background of empirical data from which a weight reduced advanced design can be derived.

The basic configuration of the laboratory model pump should be that of Figure 7.2 with pump elements assembled from sections of available SAES C-100 pump cartridges. There should be, however, some variations to this design to facilitate the testing effort. The pump housing, rather than being a fully welded unit, should have a flange disconnect. This will allow replacement of spent cartridges without time consuming and expensive fabrication of a new housing. The pump should be provided with vacuum connections for attachment to a system. Included with the system is a high pressure gas source, valves, a mass spectrometer and a pressure gauge, which simulates the system of section 4.1 .

The tests performed on this laboratory model will be simulated operational sequences. The controlled parameters will be the flow into the system, the operating temperature, the pump activation procedure, and the durations of the intake and processing intervals. Measured parameters will be the amount of gas admitted into the processing volume, the total pressure in the processing volume (i.e. the pump housing) after processing, and the gas composition in the processing volume as determined by a mass spectrometer. A suitable gas mixture is 1% air in carbon dioxide. This provides a source that has approximately 100 parts per million (PPM) of noble gas. The

gross behavior of this system can be observed by monitoring the Argon content in the processed gas. Present in air in roughly 9300 PPM Argon will be present in the mixture at 93 PPM and will constitute at least half of the gas in an adequately processed sample. Neon and helium provide a sensitive measure of the effectiveness of the system since their abundance in the input mixture, at less than 1 PPM, is not readily detectable with a small mass spectrometer but their abundance in a suitably processed sample should be of the order of a part per thousand, a readily detectable level.

It is estimated that the production and testing of the laboratory model of a noble gas enrichment pump can be accomplished in six months for \$20,000. The period of performance is set at six months to assure delivery of parts. Actual design, fabrication, testing and reporting could be accomplished in 90 days. A minimal amount of design is required because of the results of the current program and because the pump system can be fabricated entirely from commercially available parts. Fabrication consists of machining, welding and mechanical assembly. A summary of the basis for the estimate is given below.

	<u>Man Hours</u>
(1) Design Laboratory test model pump.	60
Design pumping element assembly.	
Design heater.	
Design enclosure.	
(2) Construct laboratory model pump	100
with removable cartridge and electrical heater.	
Machine	
Weld	
Assembly	

	<u>Man Hours</u>
(3) Evaluate Pump System	300
Test setup	
Determine pump parameters.	
Pressure, temperature gas mixtures and effect of enclosure.	
(4) Evaluate results and report findings	120
(5) Materials	
a) Getter material	
b) Heater flanges	
c) Conflat 4½" O.D. flanges	
d) Housings	
e) Heaters	
f) Conflat flanges 2 3/4" O.D.	
g) Valves all metal with conflat flanges	
h) ¼" stainless steel tubing	
(6) Test supplies and hardware	
Estimated time for program = 6 months	
Estimated cost = \$20,000	

REFERENCES

1. ST101 Literature from S.A.E.S. Milano, Italy, which include:
ST101 Non-evaporable Getters Document G72031
SORB-AC Cartridge Pump Operating Instructions Ref 71102
and DC224, SORB-AC Cartridges for Non-evaporable
Cartridge Vacuum Pumps AC69124 (Printed in Italy)
2. Barosi, A. and T. A. Giorgi, "A Non-Evaporable Getter for Low Temperatures" presented to the Second Annual Conference on Ultra High Vacuum at Institute of Physics at the University College of Swansea 17-19 April 1972
3. Telephone conversation with Dr. T. Giorgi at S.A.E.S., May 25, 1973
4. Lichtman, D. and A. Hebling, Specific Gas Reactions of Cer Alloy 400 Getter Material "Vacuum" Vol. 11, 1961, p. 109-113
5. Telephone conversation with Bernard Berson of Ronson Metals Corporation, May 1973.
6. Giorgi, T. and F. Ricca, On the Residual Pressure of Nitrogen, Carbon Monoxide and Hydrogen over Bulk Getters of Thorium and Zirconium Alloys, Supplements Al Nuovo Cirnento Volume 1, No. 2, 1963, p 612-626
7. Cer Alloy 400 Continuous Getter General Information, Ronson Metals Corporation 45-65 Manufacturers Place, Newark, New Jersey
8. della Porta, P. T. Giorgi, S. Origlio and F. Ricca, Investigations Concerning Bulk Getters from Metals of IVth A Group and Thorium. 1961 Transactions of the Eighth Vacuum Symposium and Second International Congress Pergamon Press 1962, p. 229-238

REFERENCES (Continued)

9. Stout, Virgil L. and Martin D. Gibbons, Method of Gettering Using Zirconium Titanium Alloy Patent 2,926,981 United States Patent Office
10. Isotherm Data Sheet No. 24 Carbon Dioxide Adsorption Union Carbide Adsorbents and Catalysts
11. Turner, F. T. and M. Funlief, Performance Criteria for Sorption Pumps. 1961 Transactions of the Eighth Vacuum Symposium and Second International Congress, Pergamon Press 1961, p 300-306