

56p

(NASA-CR-135769) THE VEGA PROGRAM, (Jet Propulsion Lab.) 56 p

Clark
N73-74187
Unclas
00/99 19494

CN-73009

REPORT NO. 30-6

THE VEGA PROGRAM

~~PRE RELEASE~~

CLASSIFICATION CHANGE

~~This document shall not be distributed outside the JPL facility and shall not be made available to the public. The document shall remain classified until further notice.~~

By authority of [redacted] E.O. 11652
Change by General Merson Date 8-22-73

JET PROPULSION LABORATORY
CALIFORNIA INSTITUTE OF TECHNOLOGY
PASADENA, CALIFORNIA
JUNE 10, 1959

~~This document contains information affecting the national defense of the United States, within the meaning of the Espionage Laws, Title 18, U.S.C., Sections 793 and 794, the transmission or revelation of which in any manner to an unauthorized person is prohibited by law.~~

REPRODUCED BY
NATIONAL TECHNICAL
INFORMATION SERVICE
U. S. DEPARTMENT OF COMMERCE
SPRINGFIELD, VA. 22161

~~EXCLUDED FROM GDS~~

000313
56

National Aeronautics and Space Administration
Contract No. NASw-6

N73-74187

REPORT No. 30-6

THE VEGA PROGRAM



W. H. Pickering, *Director*
Jet Propulsion Laboratory

JET PROPULSION LABORATORY
California Institute of Technology
Pasadena, California
June 10, 1959

REPRODUCED BY
NATIONAL TECHNICAL
INFORMATION SERVICE
U.S. DEPARTMENT OF COMMERCE
SPRINGFIELD, VA. 22161

PREFACE

This report provides a general introduction to the National Aeronautics and Space Administration's *Vega* program. It is intended to serve as an over-all system description and not as a technical specification.

As of the publication date of this report the *Vega* program and vehicle system are in the early planning and development stage. Therefore, much of the information contained herein is a projected estimate of these plans and is subject to considerable change as the program evolves. For example, other programs such as *Mercury* and *Centaur* will have system and facility requirements in common with *Vega*; where possible, these will be used to avoid duplication.

~~CONFIDENTIAL~~**CONTENTS**

	Page
I. Introduction	1
II. Vega Vehicle Applications and Capabilities	3
A. Payload Capability	3
B. Accuracy	3
III. Vega Vehicle Description	6
A. Flight Operation Sequence	8
B. Engines	8
C. Guidance and Control	10
D. Airborne Instrumentation	16
IV. Vega Support Equipment and Operations	19
A. Launch-to-Injection Net	19
B. Deep-Space Net	21
C. Vehicle Support	25
V. Vega Planning	34
A. Scheduling	34
B. Reliability	34
C. Payload Integration	39
D. Growth and Improvement	39
VI. Program Organization	41
Appendix. Deep-Space Exploration	42

TABLES

1. Estimated Injection Errors, Phase I System	5
2. Vega Engine Characteristics	10
3. Approximate Number of Telemetry Measurements	18
4. Telemetry System Information	18
5. Summary of Stations for Vega Launch-to-Injection Net	22
6. Communication Range Capability Plan for Deep-Space Net	25
7. Prelaunch Instrumentation List for Vega	33

~~CONFIDENTIAL~~

TABLES (Cont'd)

	Page
A-1. Deep-Space Missions of Vega Payloads	44
A-2. Expected Payload Guidance for Space Missions	44
A-3. Power Requirements Estimate for Deep-Space Missions	45
A-4. Characteristics of Power Sources	46
A-5. Requirements for Control of Vehicle Disturbances	47
A-6. Vega Communication System Parameters	51
A-7. Payload Communication System, Venus Trajectory Power and Weight Requirements	51

FIGURES

1. Vega Schedule	2
2. Gross Payload Definition	4
3. Gross Payload Weight for a Three-Stage Vehicle as a Function of Hyperbolic Excess Speed	4
4. Gross Payload Weight for a Two-Stage Earth Satellite Vehicle	4
5. Definition of Injection Coordinates	5
6. Vega In-Flight Separations	7
7. Third-Stage and Payload Installation Showing Disposable Nose Fairing	8
8. Vega Vehicle Design Dimensions	9
9. Powered Flight Trajectory for Interplanetary Mission	9
10. Powered Flight Trajectory for Earth Satellite Mission	9
11. Vega Second-Stage Propulsion System Employing GE 405H-2 Rocket Engine	11
12. Vega Third-Stage Propulsion System	12
13. Block Diagram of Vega Injection Guidance System	13
14. Block Diagram of Autopilot	14
15. Functional Block Diagram of Controller	15
16. Guidance Equipment	16
17. Vega Airborne Instrumentation	17
18. Down-Range Radio Horizons	20
19. Puerto Rico Station	21
20. Approximate Northeast Mars Trajectory Showing Typical Preinjection Flight Events	22

~~CONFIDENTIAL~~**FIGURES (Cont'd)**

	Page
21. Launch Instrumentation Station	22
22. Antenna Elements of Payload Telemetry and Tracking Ground Station	23
23. JPL Down-Range Instrumentation Station	24
24. Communications Net	26
25. Goldstone Station as Employed in Tracking <i>Juno II</i> to 407,000 Miles on March 6, 1959	27
26. Major Operations in Support of Vega Vehicle	29
27. Typical Ground Support Equipment for Vega Vehicle	31
28. Ground Monitoring System	33
29. Composite Vega System Schedule	35
30. Flight Preparation Schedule for Vega Vehicle	37
31. Major Contractual and Technical Direction Channels for the Vega Program	41
A-1. Small N_2H_4 Rocket Developed for Payload Use on <i>Juno II</i>	48
A-2. Small Solid Kick Rocket Employed on <i>Explorer VI</i>	48
A-3. Payload Communication System	50

~~CONFIDENTIAL~~

~~CONFIDENTIAL~~

ABSTRACT

A general description of the *Vega* program is given. The description of the vehicle is an over-all system description and not a technical specification. Vehicle applications, capabilities, support equipment, and operations are discussed together with projected program plans and schedules.

I. INTRODUCTION

The exploration of space requires the use of vehicles having payload-weight capabilities consistent with increasing space-experimentation demands. At present, the largest space-research vehicles are either multistage rockets using a *Thor* or *Jupiter* IRBM as the first stage, or two-stage rockets consisting of an *Atlas* ICBM as a first stage and relatively small second stages.

The *Vega* program was initiated by the National Aeronautics and Space Administration to provide a space-research vehicle capable of launching significant earth-satellite and deep-space payloads at the earliest possible time. Earth-satellite payloads of several tons and deep-space payloads of $\frac{1}{4}$ to $\frac{1}{2}$ ton are within the capability of this vehicle. As currently envisioned, the *Vega*, through normal growth and performance improvement, will pro-

vide a continuing space-science research vehicle for some years to come.

The first stage of the *Vega* is an *Atlas* ICBM, modified to accommodate larger upper stages than are presently used. The second stage consists of propellant tanks fabricated from a modified *Vanguard* first-stage engine and *Atlas* tank components. For missions requiring a high velocity increment, such as deep-space probes or high-altitude satellites, a third-stage propulsion system developed by the Jet Propulsion Laboratory will be employed.

In addition to supplying the third stage and certain scientific payloads, JPL will provide the technical direction for the over-all system. Convair Astronautics (CV-A), under contract to NASA, will design, build, test, and fire the first two stages. The engine to be used in the second stage will be supplied by the government to Convair

under a NASA contract with General Electric Corporation.

The present plans or contracts call for the firing of eight vehicles from the Atlantic Missile Range (AMR), five of which will be three-stage vehicles. It is expected that the program will be a continuing effort, with future firings from the Pacific Missile Range (PMR) and equatorial sites as well as from the Atlantic Missile Range.

The initial investment in the *Vega* program will provide facilities, support equipment, tracking and instrumentation, and a staff to conduct launchings at the rate of one *Vega* every two months. Figure 1 shows the presently planned launching program, a follow-on program, and the readiness dates required for certain key support items.

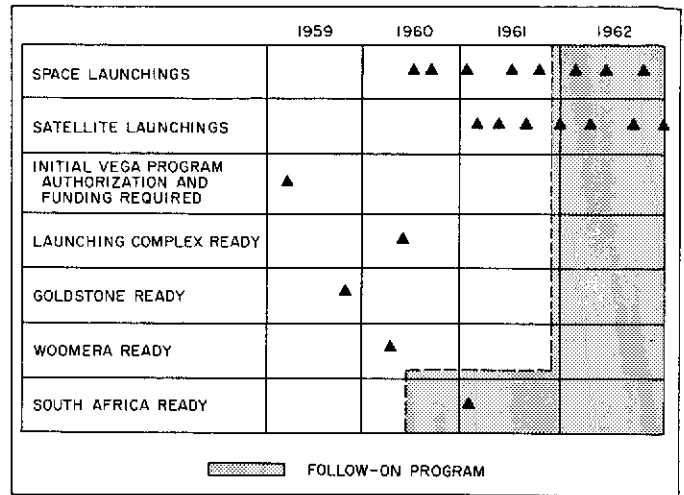

Fig. 1. *Vega* Schedule

II. VEGA VEHICLE APPLICATIONS AND CAPABILITIES

The *Vega* vehicle system is designed to have multiple capabilities and will be required to launch artificial earth satellites with 3000- to 5000-lb gross payloads as well as lunar, planetary, and interplanetary probes carrying 300- to 1000-lb gross payloads. During the first series of *Vega* launchings, extending through 1961, the *Vega* vehicle system will have the capability of performing the following missions:

1. Artificial earth satellites to make meteorological observations and to be launched into circular orbits with altitudes of 600 ± 25 miles.
2. An artificial earth satellite acting as a communications relay to be launched into a high equatorial orbit at an altitude necessary for a 24-hour period and an orbital stability keeping it within line of sight of the United States for 6 months, or orbiting multiple balloons serving as reflectors at an altitude of about 3000 miles.
3. Lunar probes, to be (1) flown near the moon on a single pass, and (2) put into orbit around the moon for long-term observations of the lunar surface and the characteristics of space in the immediate vicinity of the moon.
4. Planetary shots directed as near misses of Mars and Venus, measuring characteristics of these planets as well as characteristics of interplanetary space between earth and the target planet.

The three-stage version of the *Vega* vehicle will be required for all these missions excepting that of the meteorological satellites, which will probably require only two stages. The satellite launchings may require a restart capability in the final stage, i.e., a restart capability of the second stage for the meteorological satellites and of the third stage for the communications satellite.

The requirements of the *Vega* program do not permit a long-term development program for the vehicle system. The system must become operational during the first four launchings; even the first operation will undertake at least some aspects of the space science program.

A. Payload Capability

Gross payload includes everything injected except the empty final-stage rocket (Fig. 2). The best present estimates of performance for the vehicle are given in Figs. 3 and 4. Figure 3 shows the gross payload weight for the three-stage vehicle as a function of hyperbolic excess speed. Speeds corresponding to some typical interplanetary missions are indicated. Figure 4 shows the performance for the two-stage earth-satellite version as computed by CV-A.

For the interplanetary missions, these performance estimates are based on launching from AMR, with final-stage firing after a prolonged coast. The vehicle will coast at an altitude near 100 nautical miles in order to satisfy geometric requirements for the interplanetary flights. For the earth-satellite missions, an AMR launching into a 36.6-deg inclined orbit is assumed, with ascent by means of a transfer ellipse and one restart of the second-stage engine.

For the 24-hr satellite mission, the required speed increments are such that three stages would probably be used for injection into the transfer ellipse, with either a restart of the third stage or a small fourth stage providing the final acceleration to circular-orbit speed. Assuming equatorial launching, the gross payload weight of the 24-hr satellite would be about 1000 lb.

B. Accuracy

Pertinent accuracy information for the *Vega* injection guidance system is given in Table I. All coordinates are referred to the center of the earth (Fig. 5). From this origin, altitude y is the radial distance to the vehicle, range angle θ is the angle at the center of the earth subtended by the flight path, speed v is the magnitude of the velocity vector, path angle is measured from the local horizontal plane to the velocity vector, cross-range displacement z is measured from the trajectory plane, and yaw angle σ is measured from the trajectory plane to the velocity vector.

Table I lists the estimated one-sigma errors in the coordinates at injection due to errors in the *Vega* Phase I injection guidance system. In preparing the figures, which

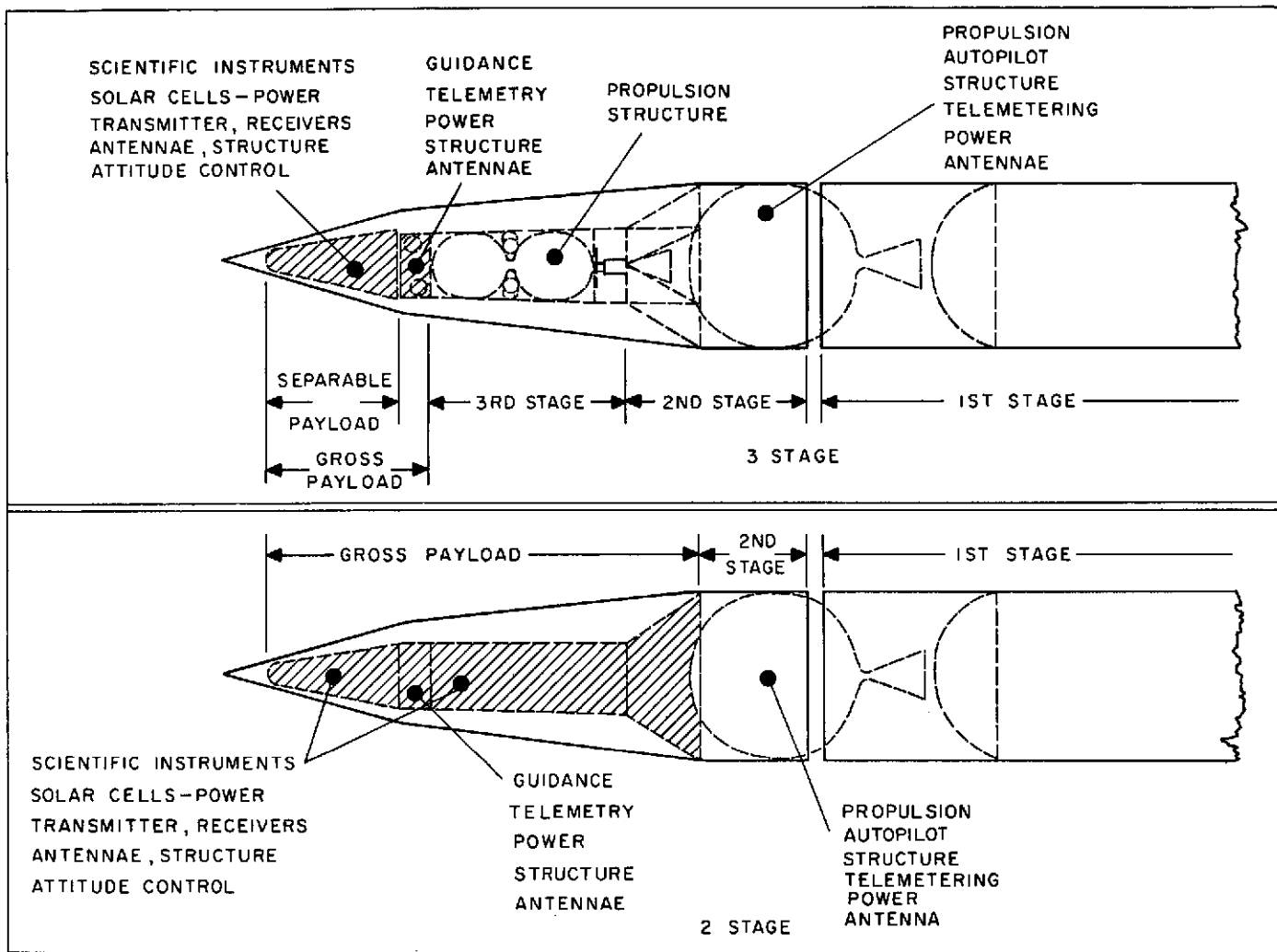

Fig. 2. Gross Payload Definition

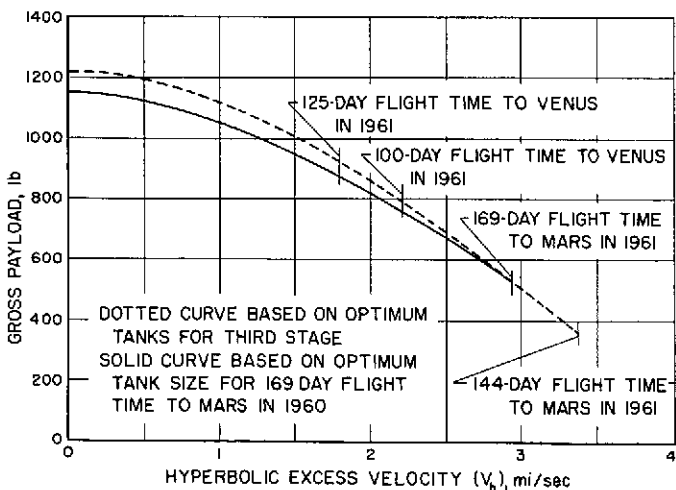

Fig. 3. Gross Payload Weight for a Three-Stage Vehicle as a Function of Hyperbolic Excess Speed

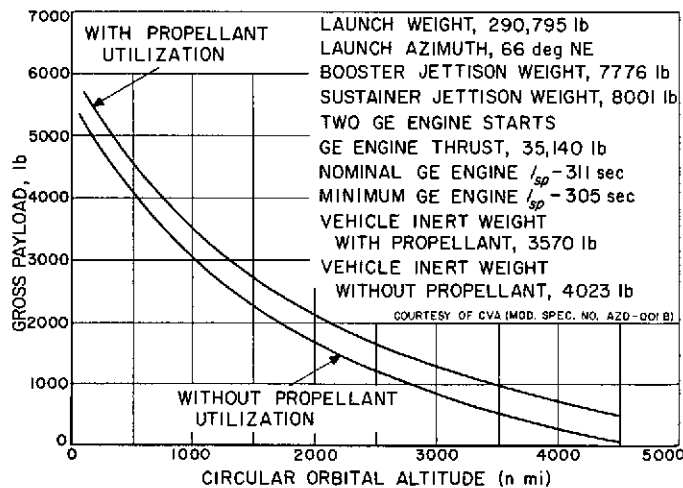

Fig. 4. Gross Payload Weight for a Two-Stage Earth Satellite Vehicle

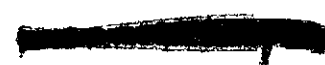

Table 1. Estimated Injection Errors, Phase I System^a

Quantity	Symbol	Units	Estimated Error
Altitude	Δy	mi	5-10
Range angle	$\Delta \theta$	millirad	2-4
Speed	Δv	ft/sec	40-70
Path angle	$\Delta \gamma$	millirad	2-4
Cross-range displacement	Δz	mi	5-10
Azimuth angle	$\Delta \sigma$	millirad	1-3

^aAssumes coasting orbit.

are preliminary estimates only, it was assumed that a coasting orbit would be used.

In summary, it is estimated that the Phase I injection guidance system will provide the following typical capabilities:

- Satellite orbital accuracy: less than 100 miles (apogee-perigee difference).
- Lunar miss: less than 5000 miles.
- Mars miss: less than 500,000 miles.
- Venus miss: less than 250,000 miles.

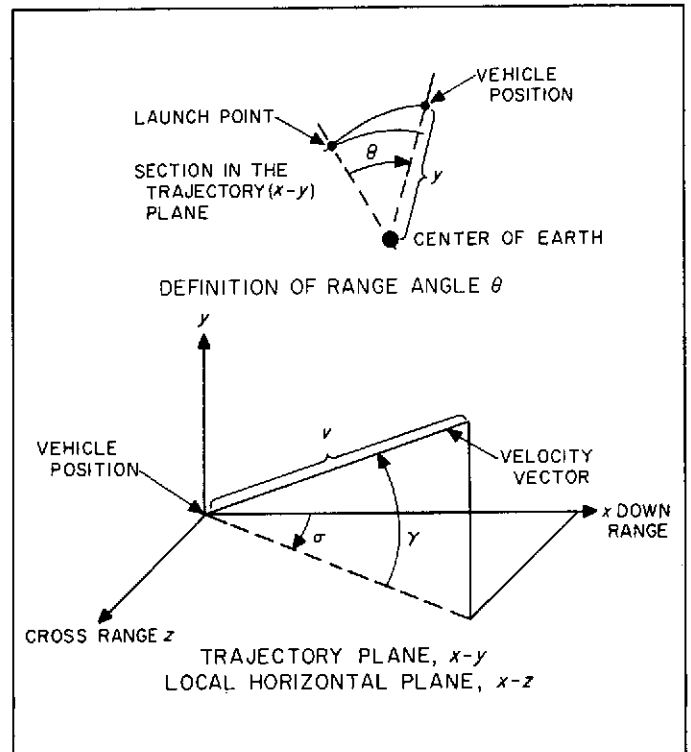

Fig. 5. Definition of Injection Coordinates

III. VEGA VEHICLE DESCRIPTION

The design of the *Vega* vehicle has been influenced by the relationship of this program to the *Centaur* program, the objective of which is to develop a high-energy second stage to be used with the *Atlas*. The *Vega* program, which uses the *Atlas* as modified for common *Vega* and *Centaur* application, is intended to provide an early space and satellite capability with conventional upper-stage propellants. The second-stage will use the GE 405H-2 engine, a modified version of the *Vanguard* first-stage powerplant. In the present program, two versions of the *Vega* vehicle are planned: one version will use only the *Atlas* and GE 405H-2 stages, with provisions for restarting the GE engine; the other version will use an additional stage to be supplied by JPL, incorporating a new pressure-fed, 6000-lb-thrust, N_2O_4 - N_2H_4 propulsion system.

The in-flight separations of the complete vehicle are shown in Fig. 6, including the *Atlas* vehicle as modified for *Vega* and *Centaur*. The forward portion of the oxidizer tank is cylindrical, instead of conical as in the ICBM, and a stiffened monocoque shell is added to support the upper stages. *Atlas* flight tank pressures are maintained at their normal values; the tanks are pressure-stabilized so that the material remains in tension for all expected loads. The total upper-stage weight that can be carried depends on a relationship between structural loads and the *Atlas* sustainer pump suction head at the time of dropping the two booster engines. If the boosters are dropped too early, the remaining weight will be so high that axial acceleration under sustainer thrust alone will be insufficient to maintain rated suction head at the inlet to the sustainer oxidizer pump. If the boosters are carried too long, the axial acceleration loads exceed the structural limit. As upper-stage weight increases, these two conditions approach each other. With minor engine revisions and some reduction of structural safety factors, upper-stage weights (above the *Atlas* adapter) can be accommodated up to 35,000 lb, and the upper-stage tanks will be sized accordingly. If all of this weight capacity is not available in early rounds, second-stage propellant weight will be reduced as necessary, with some reduction in payload.

The second-stage structure is designed to make use of *Atlas* tank tooling. The tanks are pressure-stabilized and are 10 ft in diameter. The GE 405H-2 engine assembly is attached to the tank by means of a support similar to

that used for the *Atlas* sustainer engine. Hydrogen peroxide for running the turbine, helium for pressurizing the tanks, and hydrogen peroxide for the attitude-control jets are contained in separate spherical tanks surrounding the engine assembly. The second-stage tank assembly also incorporates a 10-ft-diameter skirt extending forward to provide attachment points for a transition section and for the aerodynamic fairing, or shroud, that covers the third stage and/or the payload vehicle.

In the two-stage version of the *Vega* vehicle, it is planned initially to build essentially a three-stage vehicle and eliminate the propulsion system, thus providing for additional payload volume.

The third stage and the transition section are shown in Figs. 6 and 7. The primary structure consists of six longerons, cross-braced by tension members. The propellant tanks and the helium spheres are supported from the longerons. The propellant tanks are made from spun, machined, and welded 2014 aluminum-alloy parts. The helium spheres are made of a titanium alloy. The thrust chamber, with its propellant valves and gimbal actuators, is mounted directly on the fuel tank. The guidance equipment is mounted at the forward end of the structure, and the separable payload vehicle is attached ahead of the guidance compartment.

The nose fairing, which covers the third stage and payload during *Atlas* booster flight, constitutes a special structural problem. Its function is to carry the aerodynamic loads during boost and to protect the internal equipment from aerodynamic heating. By using such a disposable nose fairing, the payload weight is improved over that which could be obtained if the aerodynamic-protection weight had to be carried along on the second and third stages. A similar scheme has been successfully used on the *Juno II* vehicle.¹ The fairing design must accommodate radio-frequency radiation requirements from the third-stage telemetry and payload communications systems. In the *Juno II* application, the fairing is jettisoned during a stabilized coast period after *Jupiter* cutoff. For *Vega*, it may be necessary to jettison the fairing while the vehicle is accelerating.

¹*Juno II* is the vehicle system developed jointly by ABMA and JPL, employing a *Jupiter* missile and JPL upper stages. This vehicle was the launching system for *Pioneers III* and *IV*.

~~CONFIDENTIAL~~

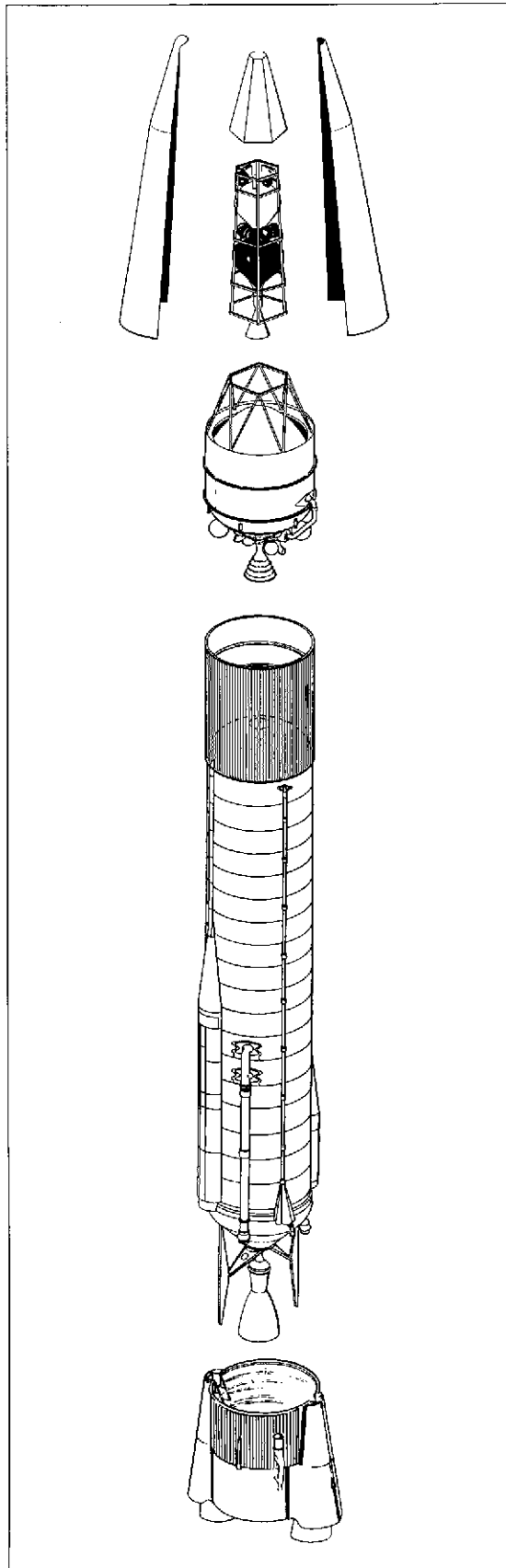

Fig. 6. Vega In-Flight Separations

~~CONFIDENTIAL~~

The current *Vega* vehicle design dimensions are shown in Fig. 8.

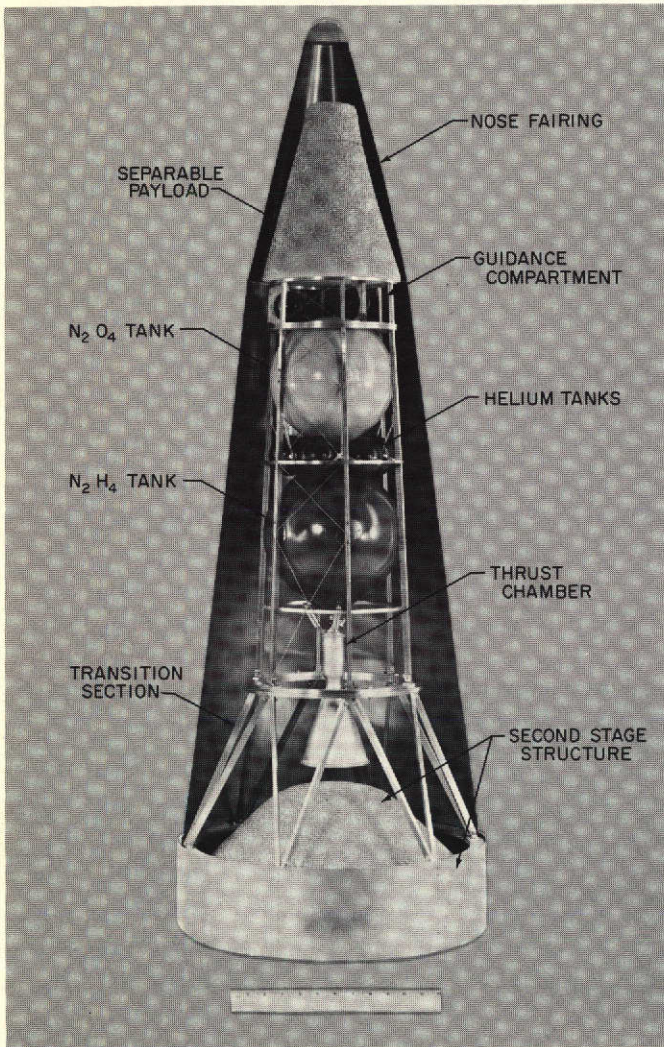

Fig. 7. Third-Stage and Payload Installation Showing Disposable Nose Fairing

A. Flight Operation Sequence

Typical flight operation sequences for satellite and interplanetary flights are shown in Figs. 9 and 10. In both instances, the powered-flight phase incorporates a coasting period.

In satellite ascents, the coasting phase is a necessary part of the transfer-orbit technique, which gives maximum payload in all but the lowest circular orbits. The coasting phase takes place between the first and second firings of the second-stage engine.

If, for interplanetary departures, an unlimited choice of launching sites and times were available there would be no need for extended coasting before injection. For AMR launchings and for realistic time constraints, however, coasting becomes mandatory to meet the proper injection conditions and still obtain a useful payload capability. On a typical interplanetary flight, the vehicle launches vertically, rolls to the proper azimuth, and then pitches over in response to an *Atlas*-type program. When the weight is sufficiently reduced, the booster engines and the nose fairing are jettisoned, the pitch program stops, and the *Atlas* sustainer continues in a constant inertial attitude. When sustainer cutoff approaches, the *Atlas* control motions are gradually reduced to stabilize the vehicle; when cutoff occurs, residual rates in pitch and yaw are small. The connectors holding the second stage are unlatched, and, for a few seconds of coasting, the 16-ton second stage drifts out of the *Atlas* adapter under the 250-lb thrust of hydrogen-peroxide jets. The second-stage engine then starts. In current trajectory calculations, the second stage has been assumed to follow a gravity-turn path. After second-stage guidance cutoff, the assembly continues to coast, with peroxide-jet attitude control acting to orient the vehicle in the desired direction for third-stage firing. After about 1 hr of coasting, the third stage is separated either by thrust of the main motor or by auxiliary rockets and burns until guidance cutoff, traveling essentially in a constant attitude. The separable portion of the gross payload then separates and coasts for a few hours or days, after which time a small "kick" rocket may be fired for final velocity correction.

B. Engines

The propulsion system for the *Vega* first stage is the North American Aviation MA-2 rocket engine system normally used with the *Atlas* vehicle. The system has one and one-half stages consisting of a jettisonable booster system with two thrust chambers and a single sustainer engine. All three fixed-thrust engines use kerosene and liquid oxygen and are operating at launch. Sea-level nominal thrust is 309,000 lb for the pair of booster engines and 57,000 lb for the sustainer engine. The booster system is jettisoned at altitude and the remaining velocity increment is supplied by the sustainer engine.

The propulsion system for the second stage is the General Electric 405H-2 engine, a modification of the

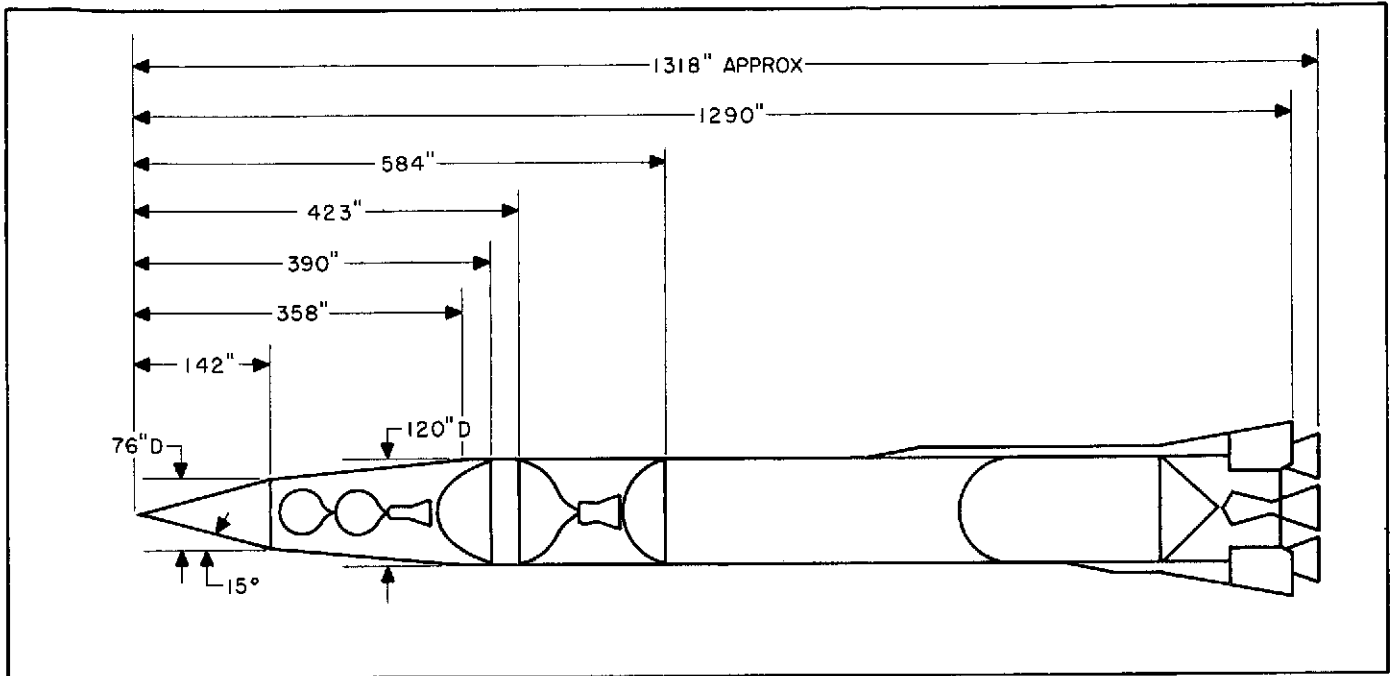

Fig. 8. Vega Vehicle Design Dimensions

The propulsion system for the third stage is a JPL-developed 6,000-lb, vacuum-thrust storable system. The oxidizer (nitrogen tetroxide) and the fuel (hydrazine) are pumped by a simple cold-helium pressurization system.

The oxidizer and fuel tanks are prepressurized during the preflight operation, and the prepressurization and

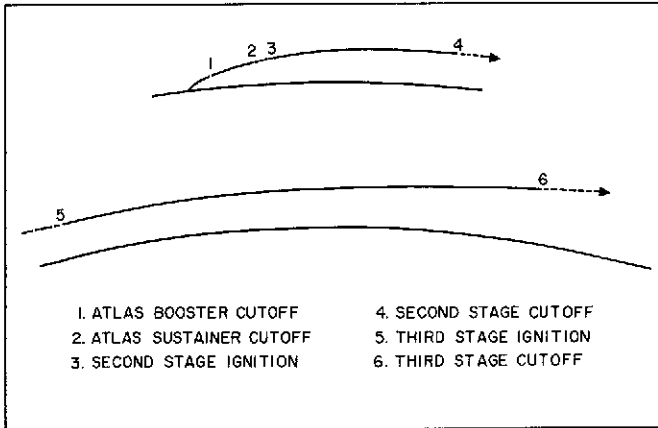

Fig. 9. Powered Flight Trajectory for Interplanetary Mission

engine presently used as the first stage of the *Vanguard* vehicle. Its thrust chamber has been modified for optimum high-altitude performance and for engine start at altitude. The 405H-2 is designed to have the capability of three in-flight starts and shut-downs.

A summary of *Vega* engine characteristics is shown in Table 2. Simplified propulsion system diagrams for the second and third stages are shown in Figs. 11 and 12, respectively.

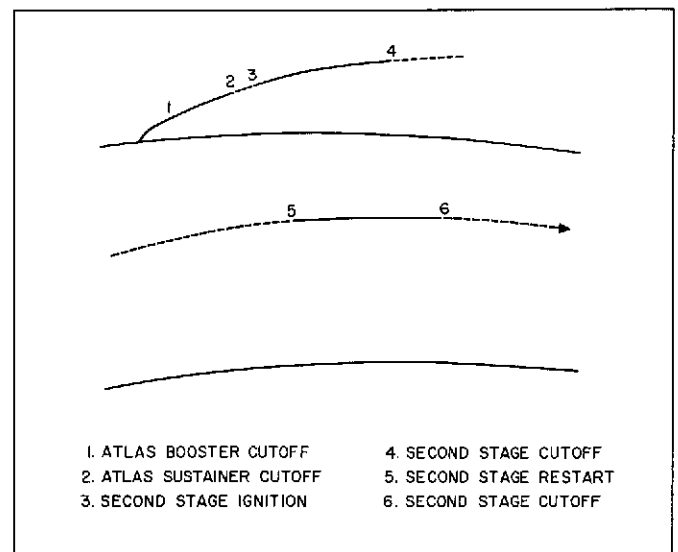

Fig. 10. Powered Flight Trajectory for Earth Satellite Mission

Table 2. Vega Engine Characteristics

Engine	Nominal Thrust, lb	Specific Impulse, sec	Chamber Pressure, psig	Fuel	Oxidizer
First-stage boosters	309,000	251 ^a	487	kerosene	LOX
First-stage verniers	2000	218 ^a	332	kerosene	LOX
First-stage sustainers	57,000	221 ^a	640	kerosene	LOX
Second stage	35,140	311 ^b	600	kerosene	LOX
Third stage	6000	300 ^b	150	hydrazine	nitrogen tetroxide

^aSea level.
^bAltitude.

helium-fill disconnects are detached at liftoff. When the *fire* signal is initiated, the normally closed explosive valve immediately downstream of the helium tanks is opened, allowing regulated pressurization of the propellant tanks. High-pressure nitrogen is simultaneously released by the opening of an explosive valve in the nitrogen system, thereby opening the main propellant valve and the pressurization valves on top of the propellant tanks. Since the propellants are hypergolic, no auxiliary starting circuitry is required. The engine, which is regeneratively fuel-cooled, operates at a nominal chamber pressure of 150 psia and delivers a vacuum specific impulse of 300 lb-sec/lb.

At shutoff, a normally closed explosive valve is fired, admitting high-pressure nitrogen to the closing side of the main propellant valve and pressurization valves.

C. Guidance and Control

The *Vega* injection guidance system (VIGS) is an all-inertial unit of moderate accuracy. It will be located in the top stage of the three-stage configuration and in the payload of the two-stage configuration. The development program for the VIGS has been divided into two principal phases. The Phase I system is an analog system consisting principally of modified *Sergeant* inertial guidance system elements. It is being developed by JPL and will be capable of performing the missions described in Table A-1. The more significant modifications are weight reduction, use of a miniaturized version of the *Sergeant* accelerometer, introduction of a digital controller, reprogramming of the computer, revision in gimbal ordering, and removal of certain "tactical" features not required for this application. The inertial reference unit will be reduced in size

and weight. The *Sergeant* middle gimbal will be used as the outer gimbal. The middle gimbal and inner frame will be appropriately scaled versions of the *Sergeant* equivalents to accommodate this size reduction. A considerable improvement in accuracy has been provided in this modification. The Phase I inner frame, for example, is designed to accommodate the several different gyros and accelerometers currently in advanced stages of development. Thus, as the improved components become qualified, they can be introduced into the system with but minor changes.

Current planning calls for the utilization of the Phase I system in at least the first five *Vega* firings. The Phase II system is expected to be a digitized all-inertial system. Current NASA Headquarters planning calls for the utilization of the *Centaur* second-stage guidance system as Phase II if its development progresses satisfactorily. It is expected that this system might be available for flights commencing in the last half of CY 1961.

The injection guidance system provides the commands necessary to steer the vehicle during powered flight, to shut down and drop engines and tankage when their usefulness is ended (staging), and to terminate rocket thrust when the proper relationships among the vehicle coordinates are met. These steering, staging, and shutoff commands are generated by prescribed mathematical operations on measurements of the vehicle motion and on certain quantities set into the guidance system before launch. In addition to the measurement, computation, and preset parameter portions of the injection guidance system, the vehicle autopilot is necessary for successful guidance. This device provides stabilizing commands for the vehicle and translates the guidance steering commands into vehicle motion.

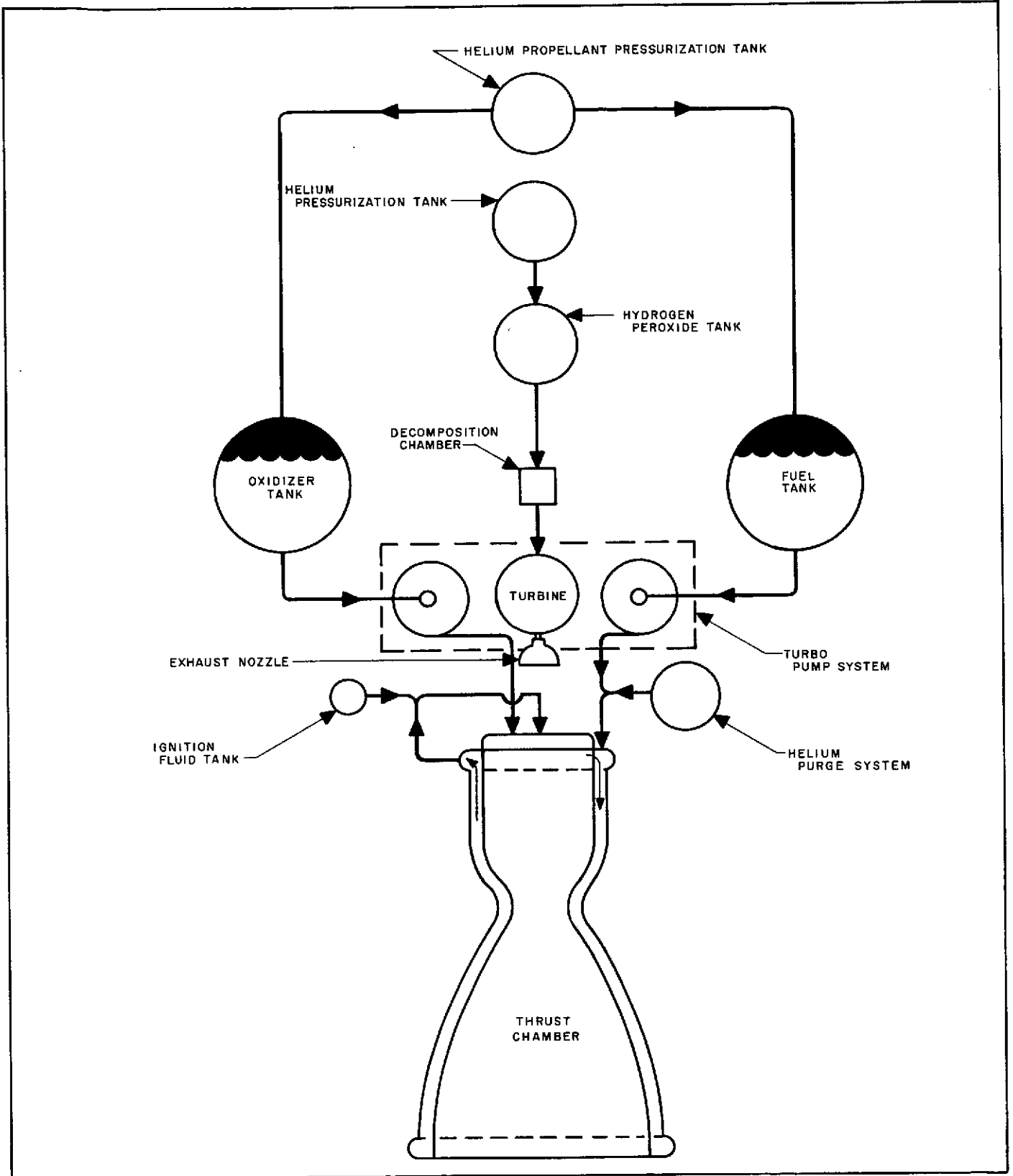

Fig. 11. Vega Second-Stage Propulsion System Employing GE 405H-2 Rocket Engine

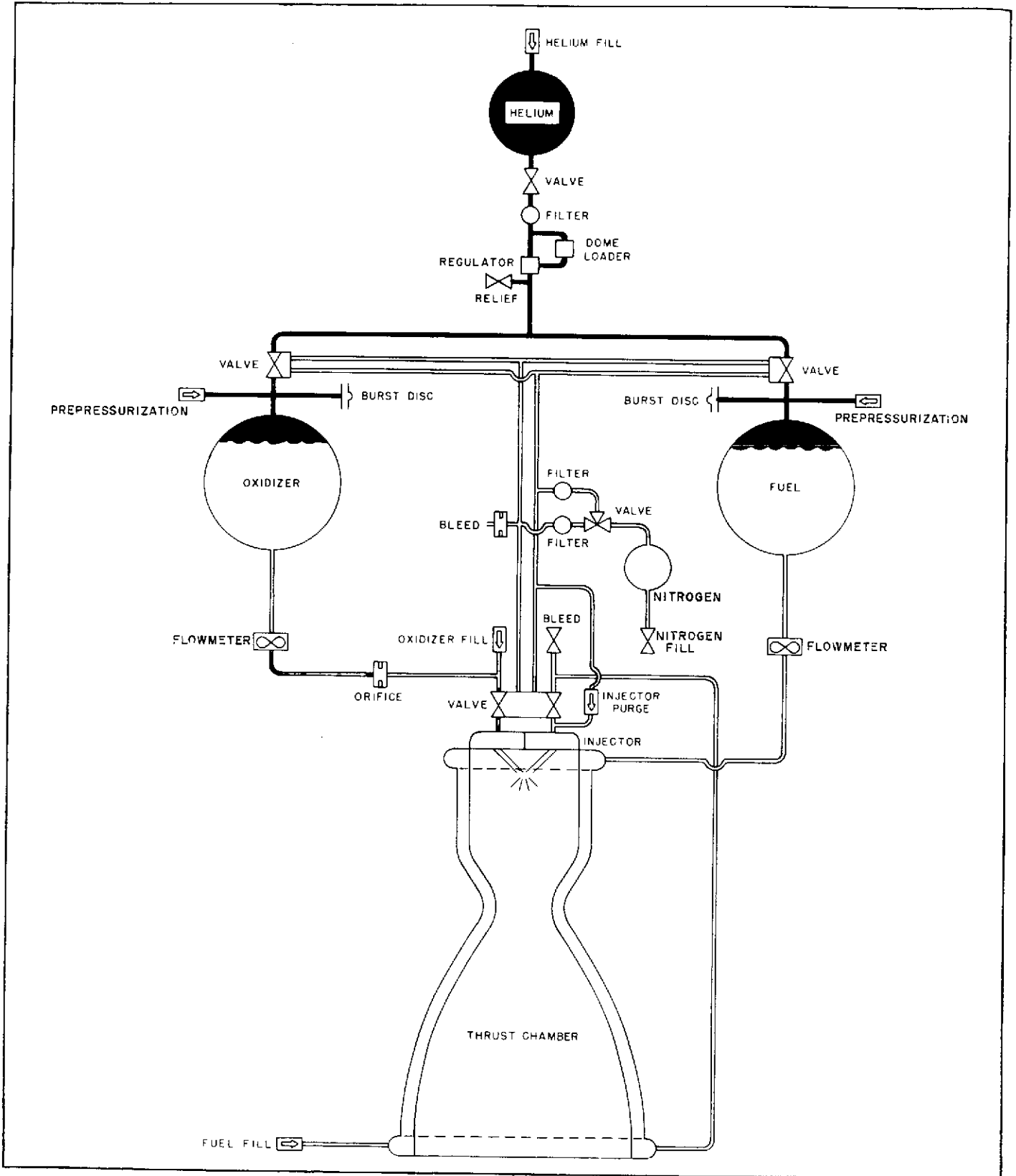

Fig. 12. Vega Third-Stage Propulsion System

A functional diagram of the Vega guidance system is shown in Fig. 13. The system obtains linear acceleration and angular position data from a three-axis stabilized platform that carries three mutually perpendicular accelerometers. The sensitive axis of one accelerometer is perpendicular to the trajectory plane and generates signals for azimuth guidance. The azimuth guidance signal is a linear combination of measured acceleration, velocity, and position normal to the nominal trajectory plane suitably limited to prevent large angles of attack.

The sensitive axes of the remaining accelerometers lie in the nominal trajectory plane in two perpendicular

directions. The signal from each accelerometer is doubly integrated (with suitable initial conditions), and these integrated accelerometer data are used to derive shutoff and pitch guidance signals. The shutoff equation is a linear combination of variations from the standard values of the measured velocity and position in each direction plus a term proportional to time-to-go to standard cutoff time.

The elevation guidance signal is the difference between the programmed standard and actual values of measured velocity in a space-fixed direction approximately normal to the velocity direction at shutoff. The direction is chosen

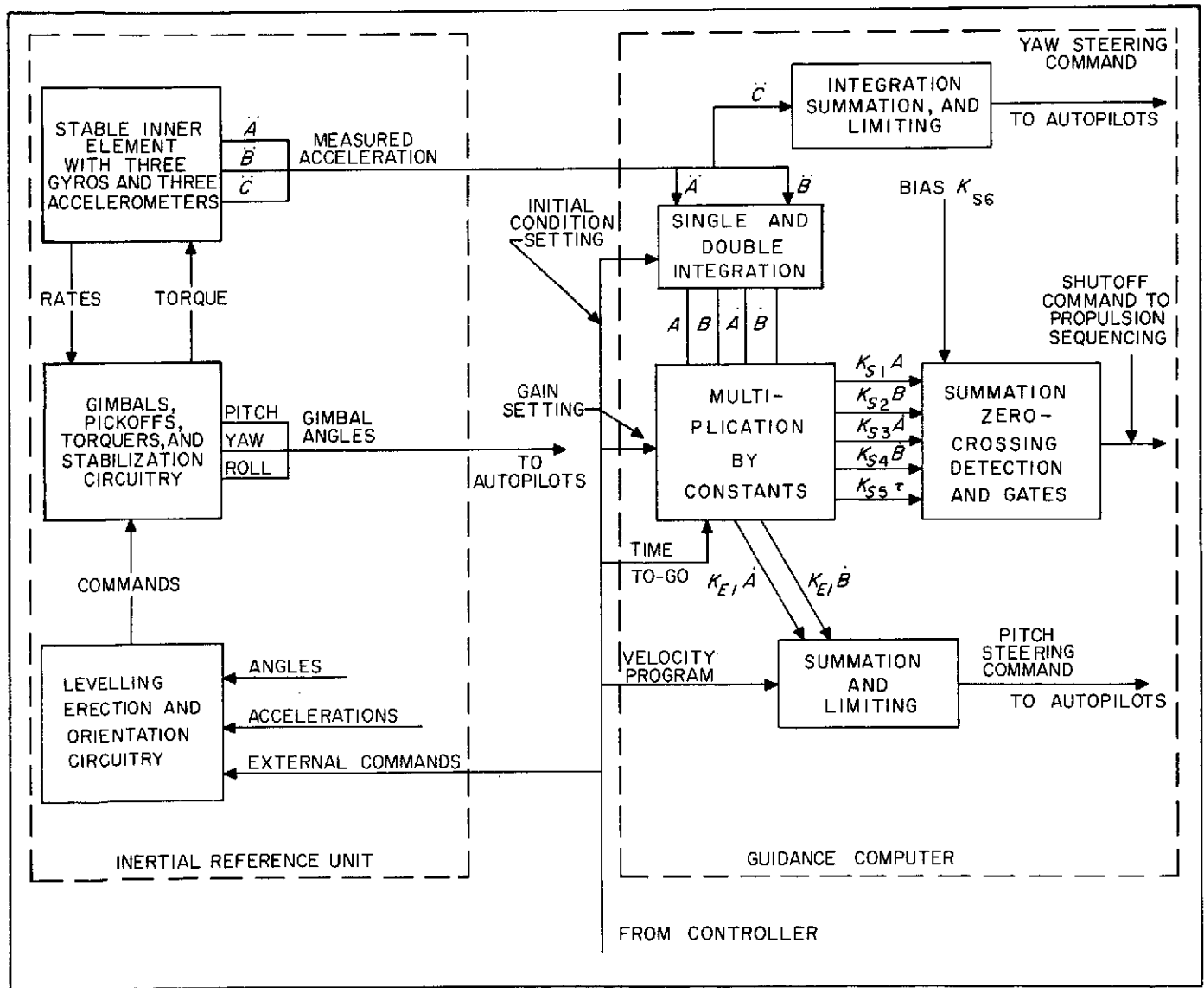

Fig. 13. Block Diagram of Vega Injection Guidance System

to minimize the effects of variations in motor performance and other quantities. The elevation guidance signal is also suitably limited to prevent large angles of attack.

The designs of the autopilots for the different stages vary. Because angular position data are directly available from the inertial reference unit, there is no need for an auxiliary set of gyroscopes in the third stage. Stabilizing rate information is obtained, with a compensating network, from the angle signals. The steering velocity command is mixed directly with the angle-plus-rate error signal. A functional block diagram of the autopilot is shown in Fig. 14.

In the first and second stages, single-degree-of-freedom floated gyroscopes provide the angular orientation data. Because of body bending and the necessity for rapid control in the flight of an unstable vehicle such as the Vega through the atmosphere, rate data are provided by separate gyroscopes. The autopilot commands are effected by torquing the single-degree-of-freedom gyroscopes to command the turning rates desired. Because the elevation velocity error signal is related to the second integral of turning rate, it appears that the additional integration

which would result from feeding this signal directly to the gyroscope torques as a rate command might cause vehicle instability. This tendency may be counteracted by a suitable signal-shaping (filter) unit located as shown in Fig. 14.

Roll control of the second stage is accomplished with hydrogen-peroxide reaction jets. Nitrogen jets provide third-stage roll control.

The initial conditions on the various data integrators are set by an automatic calibration process that removes much of the first-order effect of computer and accelerometer scale factor errors. Instead of setting a prescribed voltage as an initial condition on each of the analog integrators, the guidance accelerometers are used to sense the (known) effect of gravity at the launcher for a prescribed time. The voltages thus accumulated on the integrators are used for initial conditions and for the adjustment of the gain ratios in the shutoff and elevation computers.

To provide the flexibility in the guidance computer necessary for its various missions, certain of the parameters in the guidance system, such as the constant multipliers in the elevation and shutoff computers, must be

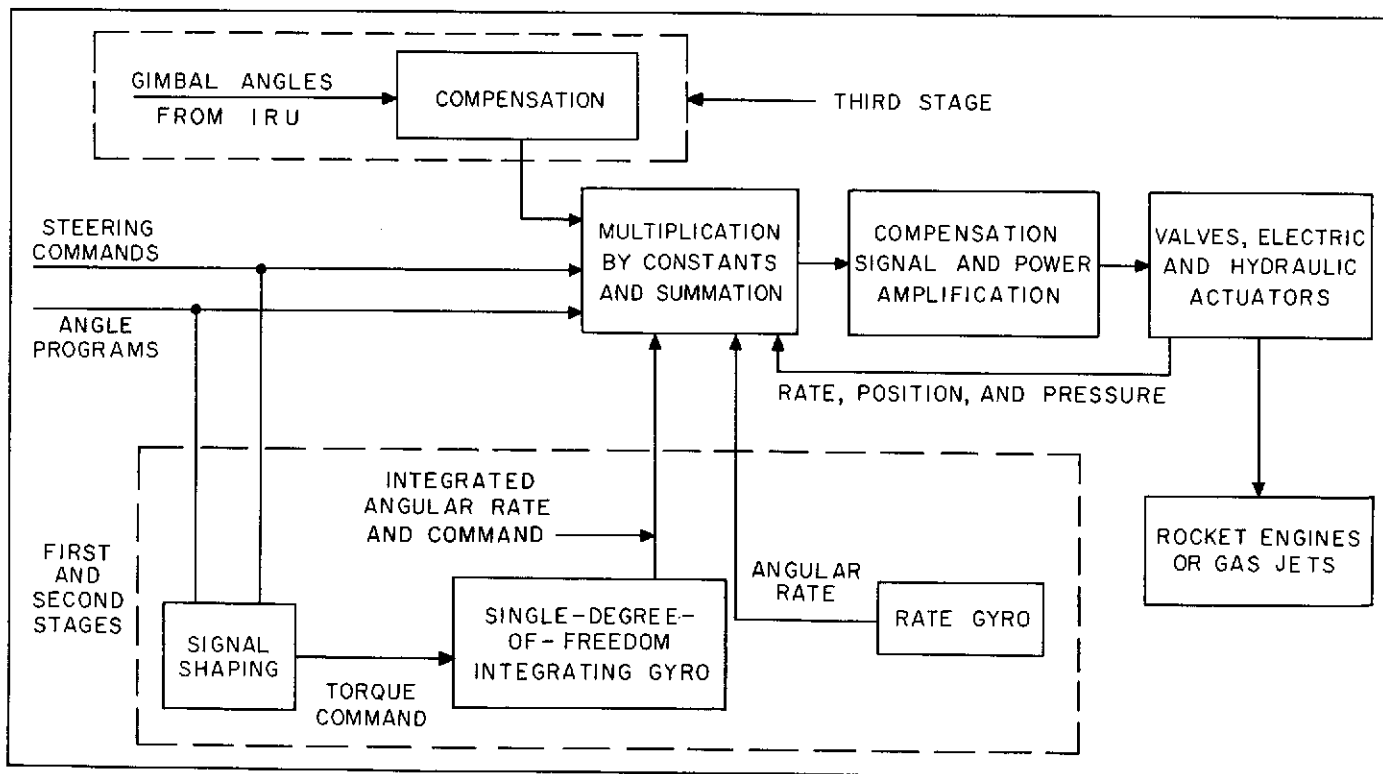

Fig. 14. Block Diagram of Autopilot

adjustable. Some of these parameters may be set far in advance of firing day; some must be set on firing day; and some must be varied remotely from the blockhouse to match the exact moment of firing.

The guidance controller (Fig. 15) provides a master time reference, generates preflight and in-flight switching and sequencing commands, provides elevation velocity and angle programs to the guidance computer and autopilot, and generates a time-to-go signal referenced to nominal cutoff time. If present investigations show the need, an adjustment to the engine ignition time at the end of a coasting or transfer orbit, based on the results of guidance, will be provided.

Guidance equipment location and interconnections for the Vega vehicle are shown in Fig. 16. The three-axis inertial-platform injection guidance system is located in the top stage of three-stage vehicles and in the satellite payload of two-stage vehicles. Each stage is supplied with its own autopilot; a single autopilot is used for both booster and sustainer portions of the Atlas. Steering commands are fed to the gimbaled-engine actuators. Hydraul-

lic actuators are used in the first and second stages and electromechanical devices are used in the third stage.

The planned interconnections are shown in Fig. 16. The third-stage guidance unit supplies steering, staging, and shutoff commands to all three stages. The booster portion of Atlas utilizes the autopilot only. Angle data are supplied to the third-stage autopilot and possibly to the second stage.

Two alternative guidance schemes, considered as back-up plans, are also shown in Fig. 16:

1. The GE radio guidance equipment is used for Atlas sustainer guidance and for booster and sustainer shutoff and staging. The third-stage unit is used for the rest of the flight. The advantage of this alternative is that system mating problems between the third-stage guidance system and the Atlas autopilot are avoided by using a system that is already mated. Disadvantages lie in the added system and prelaunch countdown complexity, the added system cost, and the requirement for coordination and use of the ground tracking and computer complex that is part

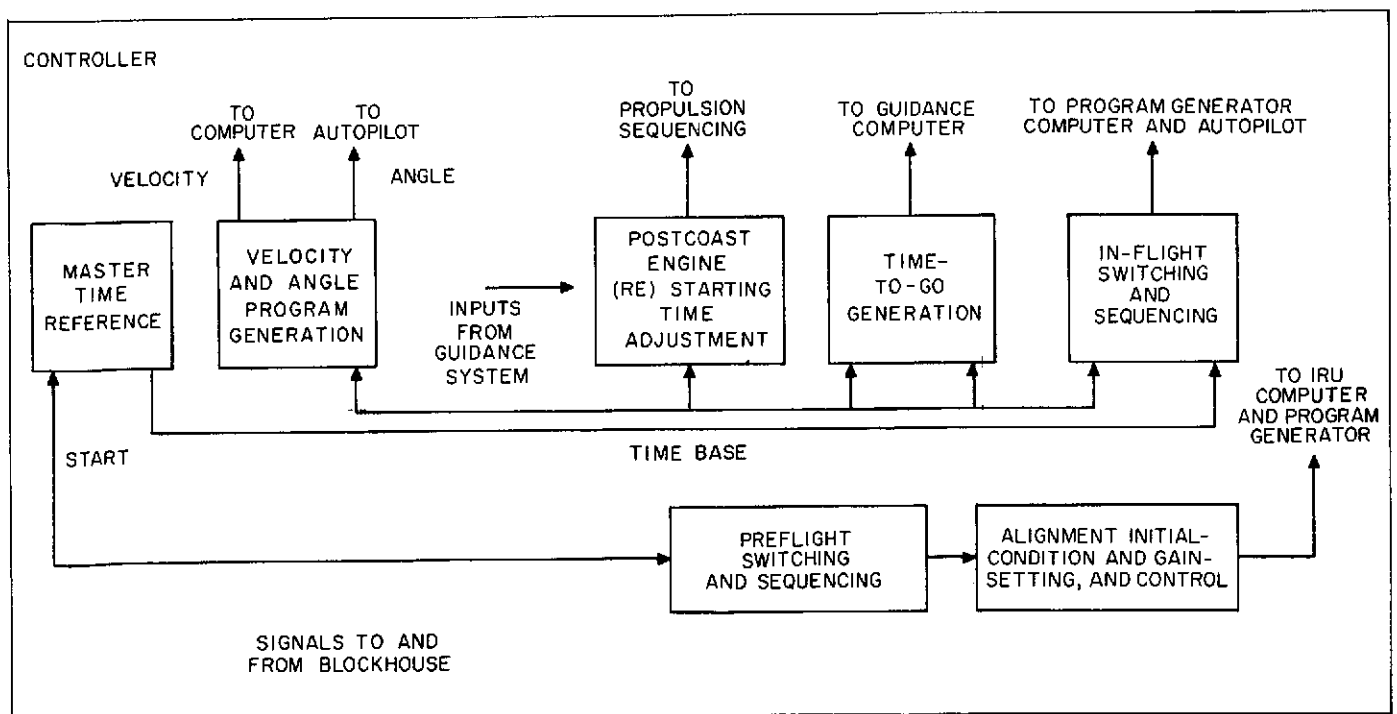

Fig. 15. Functional Block Diagram of Controller

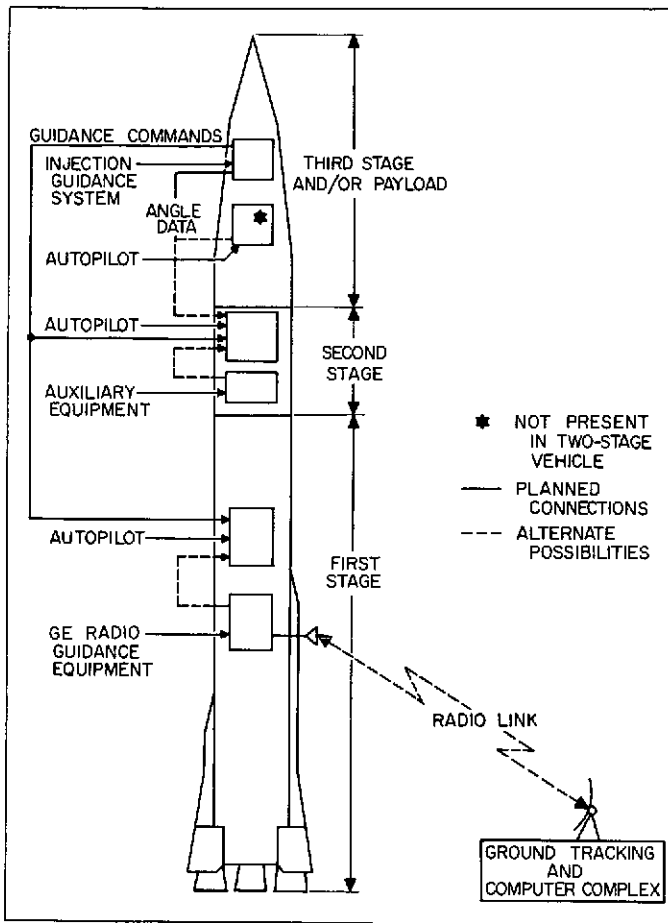

Fig. 16. Guidance Equipment

of the *Atlas* system. Furthermore, the guidance equations normally programmed for the ground computer for *Atlas* firings may not be optimal for *Vega* missions, and reprogramming may be required.

2. The GE radio guidance equipment would be used for the *Atlas*, and auxiliary equipment in the second stage would be used for guidance and shutoff of the second stage. This combination would be used for two-stage vehicles and would replace the three-axis inertial-platform guidance system. The advantages of this system are in weight saving in auxiliary equipment and lessened complexity. Disadvantages of this system are that it is less accurate than the three-axis inertial system, lacks growth potential, is unsuitable to a three-stage coasting orbit configuration, and necessitates the use of two different guidance systems for *Vega*, with the attendant loss of the advantages of repetitious use.

D. Airborne Instrumentation

Standard *Vega* airborne instrumentation requirements include the following (Fig. 17):

1. Destroy receivers.
2. Transmitter-receiver equipment to operate with ground tracking stations to make range-safety decisions and store trajectory data.
3. Payload instrumentation, as determined by the mission.
4. Telemetry equipment in each stage to provide environmental, propulsion, and guidance performance data.
5. Airborne transducers and devices to provide remote prelaunch indications in the blockhouse.

1. Range safety. The *Vega* vehicle will require a missile-destroy receiver for range-safety purposes during the first-stage burning period only. The velocity and altitude at separation are sufficient to prevent any hazard from an upper-stage malfunction. The Atlantic Missile Range requires the redundancy of two separate receivers as a precaution against receiver failure. The second stage includes a destruct charge which can disable the vehicle in the early part of the flight. The policy of AMR dictates that if a missile must be destroyed the propulsion system is shut down before igniting the destructors. The decision as to whether or not a missile must be destroyed is made by continuously predicting impact. The missile is destroyed if the predicted impact information indicates that the missile is malfunctioning and is likely to go off-range if flight proceeds.

2. Trajectory determination. Accurate trajectory data for postflight analysis are available from the Azusa system for part of the powered flight. These data are available from only the first stage since no transponder is planned for the second or third stage. Trajectory data for the remaining part of the coast and powered flight up to the point of injection will be accomplished by the use of the payload transponder and its associated ground instrumentation stations in the launch-to-injection net. The postinjection trajectory will be determined from observations made by tracking the payload transmitters with the deep-space net.

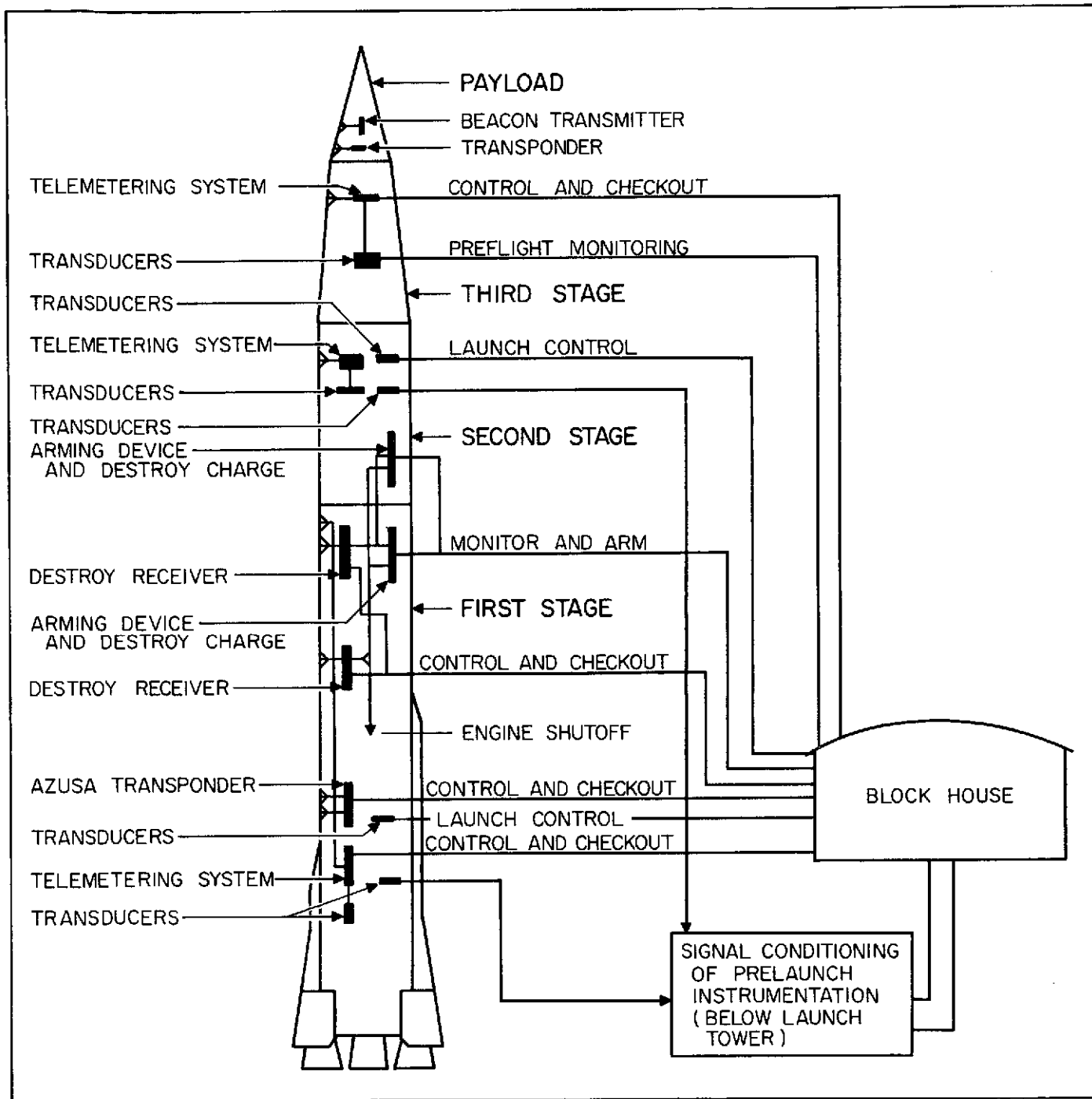

Fig. 17. Vega Airborne Instrumentation

3. *Vehicle telemetry.* The *Atlas* booster will contain one standard Convair FM/FM telemetering system and will be capable of making more than one hundred measurements.

Convair's interim operational capability (IOC) telemeter, planned for use in the second stage, is an FM/FM system which uses newer and lighter components than those used in the *Atlas* booster.

The third-stage telemetry system will be a lightweight telemeter using components developed at JPL. It will radiate 2 to 5 watts and will weigh approximately 45 lb not including a main battery. The number of measurements planned in the various areas are shown in Table 3. The characteristics of the telemetering systems are presented in Table 4.

4. *Payload telemetry.* There will be two separate radio systems on deep-space payloads. The first system, a simple beacon (transmitter only), will provide a high-reliability payload telemetry and tracking signal for approximately the first 100 hours of flight. The second system is a transponder capable of coherent "two-way" operation that provides long-range tracking, command, and telemetry capability. Both systems will radiate at approximately 960 mc (separated by a few kc); either system could be angle-tracked or used for "one-way" doppler measurement from the ground. The transponder will make possible accurate two-way doppler measurements.

In the two-stage satellite version, no fundamental problem exists in incorporating the beacon or transponder

either as part of the payload or as part of the second stage proper. This airborne equipment is basically compatible with the *Vega* launch-to-injection net, the deep-space net, and the converted Microlock network, which is employed by Signal Corps and ABMA for *Juno II* injection tracking.

Table 3. Approximate Number of Telemetry Measurements

Measurement Area	Approximate Number of Measurements		
	First Stage	Second Stage	Third Stage
Pressures	21	19	9
Temperatures	34	35	13
Vibration	1	5	2
Guidance and control	34	32	16
Range safety	5	1	0
Central power	3	3	2
Structural bending	6	4	0
Flow rates	0	3	2
Payload functions	0	0	4

Table 4. Telemetering System Information

Telemetering System	Type	System Weight, lb	Number of Measurements Planned	Transmitted Power, watts	Frequency Range, mc	Battery Life, min
Third Stage	FM/FM	45	50	5	225-260	third-stage power plus 3 min. emergency
Second Stage	FM/FM	125	100	10	225-260	
First Stage	FM/FM	350	100	50	225-260	

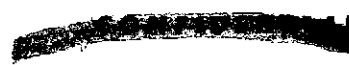

IV. VEGA SUPPORT EQUIPMENT AND OPERATIONS

A. Launch-to-Injection Net

The launch-to-injection net is required in support of the *Vega* vehicle for the following reasons:

1. Real-time trajectory information is required during first-stage burning to make the destruct decision.
2. Trajectory information is required from launch to injection during all significant burning and guidance phases to analyze vehicle performance and to provide acquisition information to the deep-space net.
3. Telemetry reception is required from launch to injection during all burning phases and significant guidance phases to analyze vehicle performance.

Owing to the nature of the trajectories, instrumentation stations for the initial *Vega* program in the vicinity of the AMR launching complex, at Puerto Rico or Bermuda, and in the vicinity of Australia, are a minimum requirement.

Figure 18 demonstrates the coverage obtained from instrumentation stations at Bermuda or Puerto Rico during the first- and second-stage burning periods for typical northeast and southeast Mars trajectories. The circles indicate the approximate radio horizons for stations located at Cape Canaveral, Bermuda, and Puerto Rico. The Puerto Rico site (Fig. 19) is developed, and JPL has a semimobile instrumentation station there that was employed on the *Juno II-Pioneer* launchings. This station will be located either at Puerto Rico or Bermuda, depending upon the trajectories.

The utilization of Australia or nearby islands as far-down-range sites for third-stage data coverage is planned. Australia is also the site for a primary deep-space net station. Figure 20 presents an approximate trajectory with third-stage burning in the vicinity of Australia, where instrumentation coverage is required.

In order to meet the three previously mentioned requirements, the equipment as described in the following material will comprise the net. Range-safety decisions will be made on the basis of Azusa, skin-tracking radars, and optical tracking systems located at Cape Canaveral and delivering data to the AMR range control building.

All of these devices are AMR-associated and are essentially limited to providing real-time data for the first-stage burning period. (They also provide stored data for post-flight analysis of that portion of the trajectory.)

The remaining stations are directly associated with the *Vega* program and are in addition to the normal AMR range equipment. They are semimobile and can be relocated as different launch areas or trajectories are employed. Wherever possible, telemetry and trajectory determination functions are combined physically, operationally, and logistically.

1. Launch stations. Trajectory data from the launch area will be based on the use of UHF vehicle equipment being developed for deep-space payload communications. The launch instrumentation station is shown schematically in Fig. 21, and the elements of the antenna are shown in Fig. 22. The launch instrumentation station will monitor and doppler-track both the payload beacon and transponder. Additionally, a transmitter of the order of 25 watts will serve to interrogate the transponder. No automatic angle tracking is planned. The station will receive and record payload telemetry functions over the UHF link. This same equipment will be utilized for prelaunch checkout and monitoring of the beacon and transponder.

Convair will provide a checkout station for the first- and second-stage FM-FM vehicle-telemetry system, which is also capable of receiving data during launch phase.

JPL will provide a checkout station for the third stage FM/FM vehicle-telemetry which is capable of data reception during the launch phase.

2. Down-range stations. One set of stations is located at either Puerto Rico or Bermuda, depending upon the trajectories from AMR launchings.

A JPL instrumentation station (Fig. 23) is employed down range. This station provides automatic angle and velocity tracking of the payload transmitter and receives and records payload telemetry functions. In addition, it provides for vehicle telemetry reception for guidance evaluation during this portion of the flight.

~~CONFIDENTIAL~~

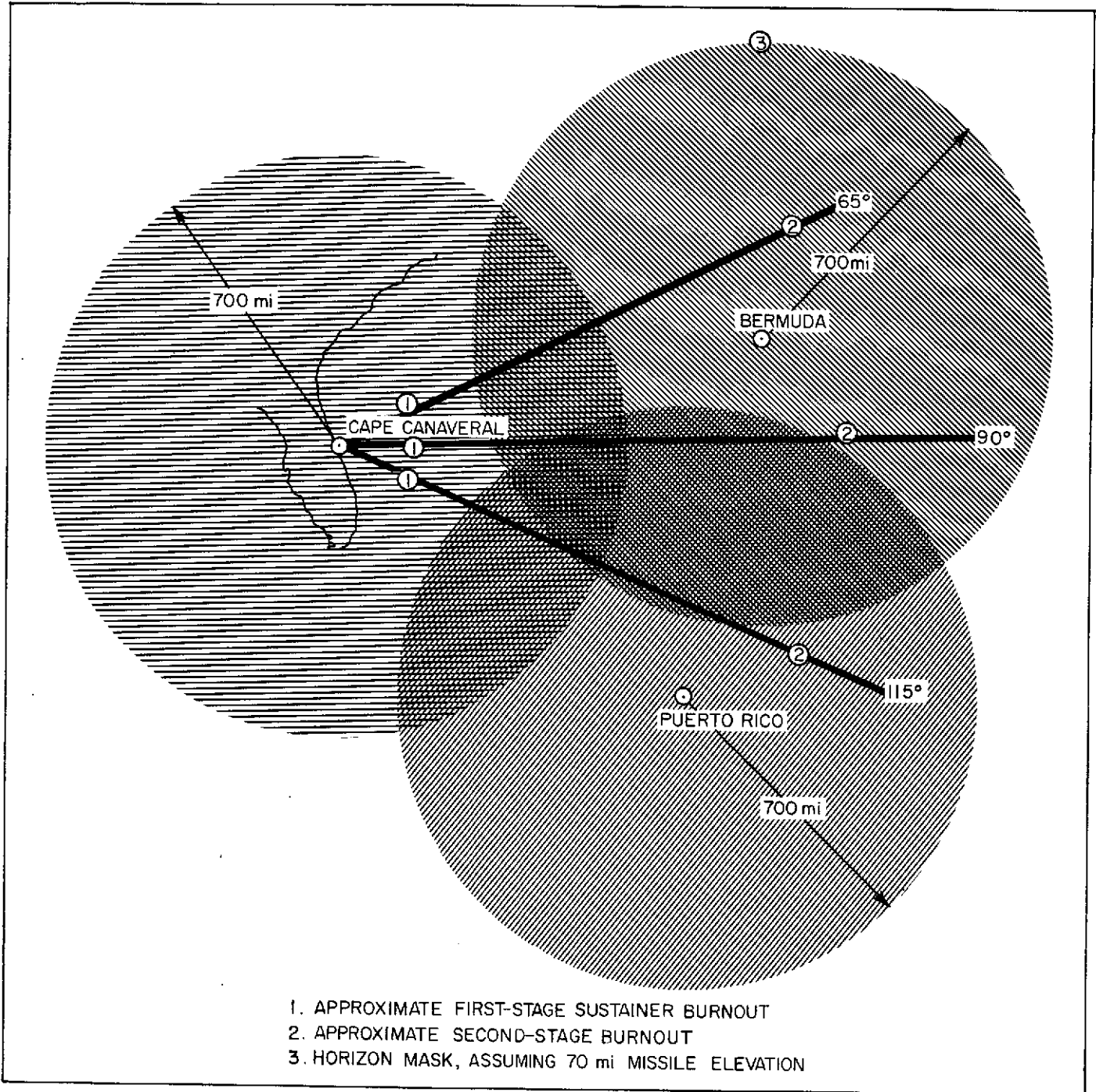

Fig. 18. Down-Range Radio Horizons

Convair will also provide a down-range vehicle-telemetry receiving station to cover second-stage burning.

3. *Far-down-range stations.* A deep-space net primary station is to be located at Woomera, Australia, and some

trajectories may be adjusted to traverse that station. Generally this is not the case; furthermore, on the first pass in a coasting orbit the large 85-ft antenna cannot meet the tracking rates.

~~CONFIDENTIAL~~

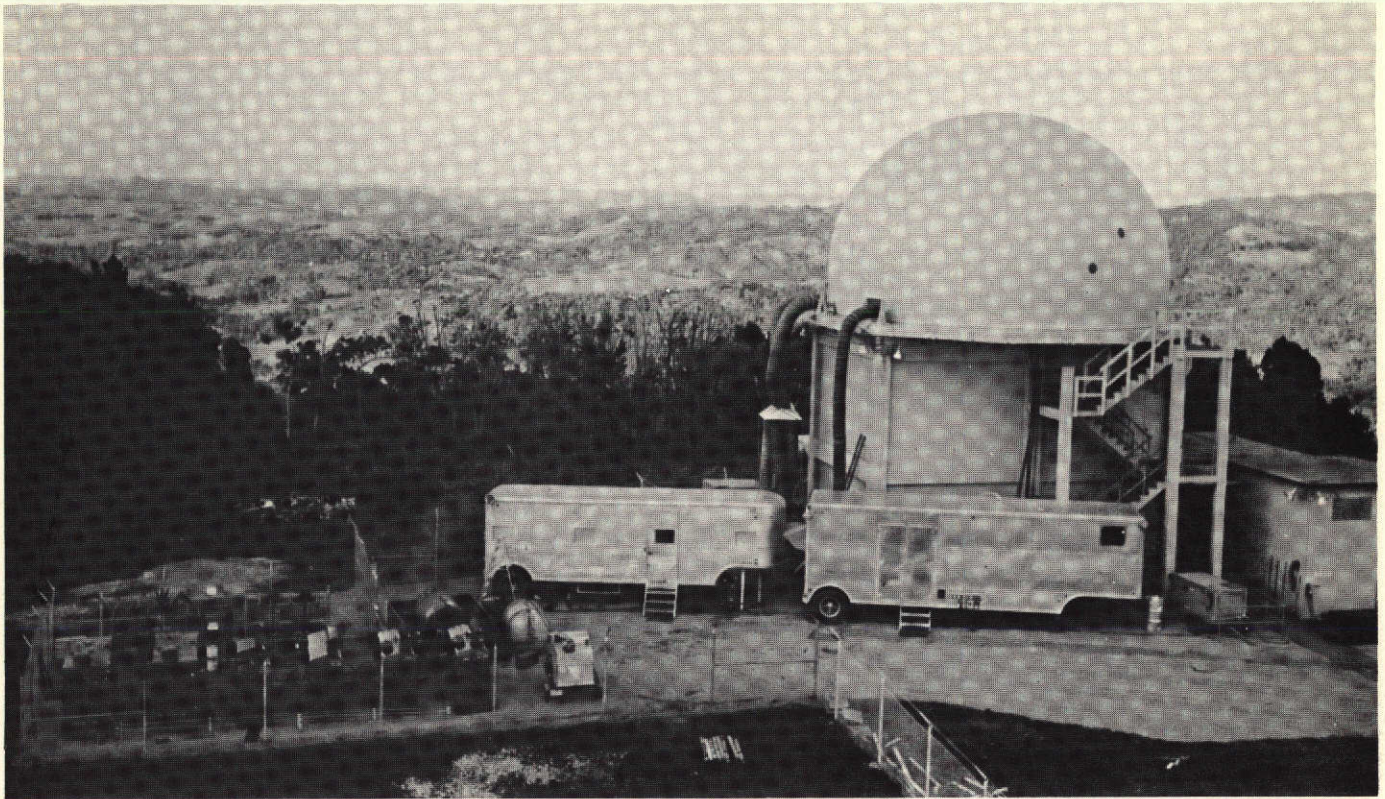

Fig. 19. Puerto Rico Station

In order to provide coverage during the third-stage burning period and possibly during the turn-around maneuver, two simple outlying substations and another instrumentation station such as the one employed down range are planned for use in the general vicinity of Australia.

Table 5 presents a summary of all *Vega* launch-to-injection stations exclusive of the AMR stations required for range safety.

A communication system is required to tie the launch-to-injection net together for data traffic. Figure 24 shows the major tracking stations and computing and communications centers comprising the *Vega* launch-to-injection net and their relationship to the control center at NASA. All points will be provided with voice, teletype, and data circuits excepting the two substations. These two stations will have one radio voice channel from the primary station at Woomera in order to receive countdown and acquisition information and to receive and transmit other technical and administrative voice traffic as required. Only real-time angle tracking data and associated predictions, calibrations, and net coordination will be trans-

mitted over the teletype and voice nets during operations. Telemetered data will be recorded, and it is planned to transmit through a converter to the appropriate data reduction center during operational lulls.

All teletype circuits are $\frac{1}{2}$ duplex, 60 wpm, expandable to full duplex, 100 wpm (other than the commercial TWX and RCA overseas TWX service). Radio channels are UHF/VHF single side band, FM or AM, expandable to multiplex operation of up to one voice and 16 teletype channels.

The tie-lines to NASA, RCA overseas TWX, and other commercial circuits are to obtain from other stations as much tracking data as can be gathered during the period through injection. After injection, the requirement for real-time data in great quantities is lessened so that, after the mid-course maneuver, only minimum communications of perhaps one teletype channel and one voice channel to each participating station will be necessary.

B. Deep-Space Net

A deep-space tracking and telemetering net, consisting of a station at Goldstone, California, Woomera,

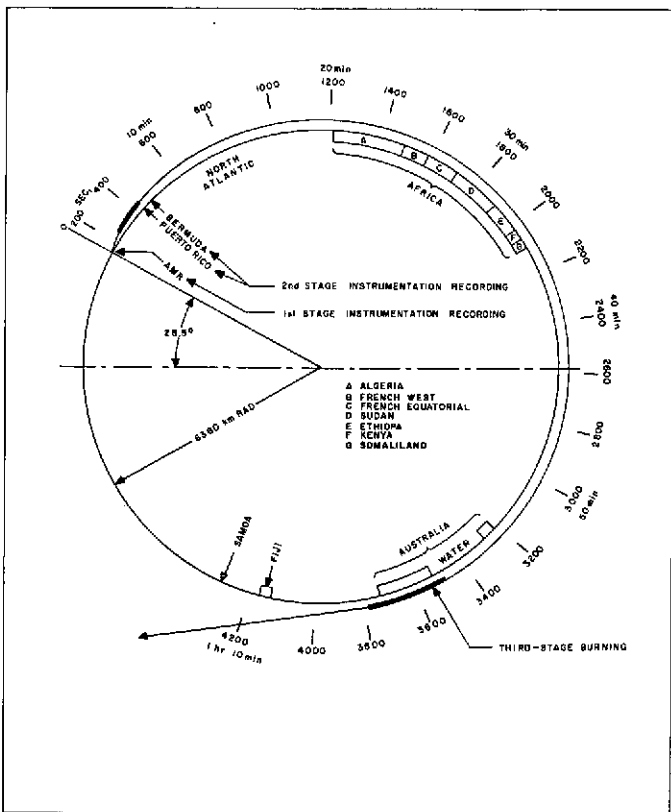

Fig. 20. Approximate Northeast Mars Trajectory Showing Typical Preinjection Flight Events

Australia, and, eventually, Johannesburg, South Africa, is being implemented at a rate governed by available funds. An estimate of availability is as follows: The Gold-

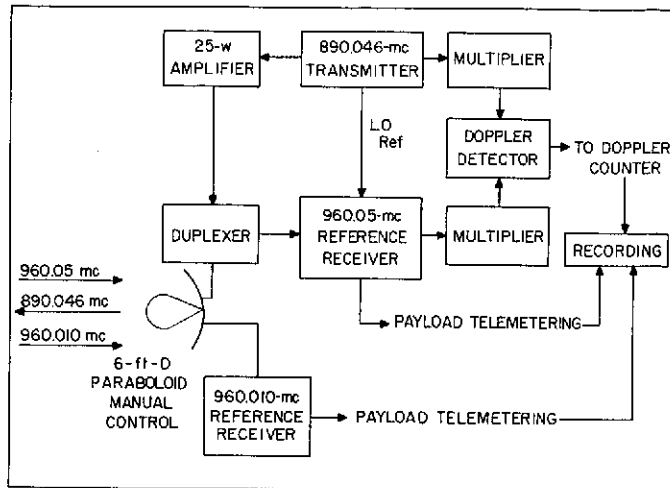

Fig. 21. Launch Instrumentation Station

stone station (Fig. 25), which was established for the *Juno II* lunar firings, will be ready at the end of CY 1959 for the *Vega* program; the Woomera station will be marginally ready for the first *Vega* launching; and the South African station probably will not be ready until the first part of CY 1961. Interim tracking and telemetering coverage from the South Africa longitude will be provided by establishing a minimal capability at either Jodrell Bank, England, or at the ARPA station in Spain. The continued use of this facility in this capacity has not yet been determined.

Each station has a capability of tracking and receiving telemetering from vehicles which are above the radio

Table 5. Summary of Stations for Vega Launch-To-Injection Net

Area	Station	Cognizance	Doppler Count	Automatic Angle Determination	Manual or No Angle Determination	Transmit Frequency, mc	Receive Frequency, mc	Payload Telemetry Capability	Vehicle Telemetry Capability
Launch	instrumentation	JPL	X		X	890	960	X	
	telemetry checkout	CV-A			X		225-260		X
	telemetry checkout	JPL			X		225-260		X
Down range	instrumentation	JPL	X	X		890	960 and 225-260	X	X
	telemetry	CV-A			X		225-260		X
Far down range (first pass)	instrumentation	JPL	X	X		890	960 and 225-260	X	X
	Substation	JPL			X		225-260		X
	Substation	JPL			X		225-260		X

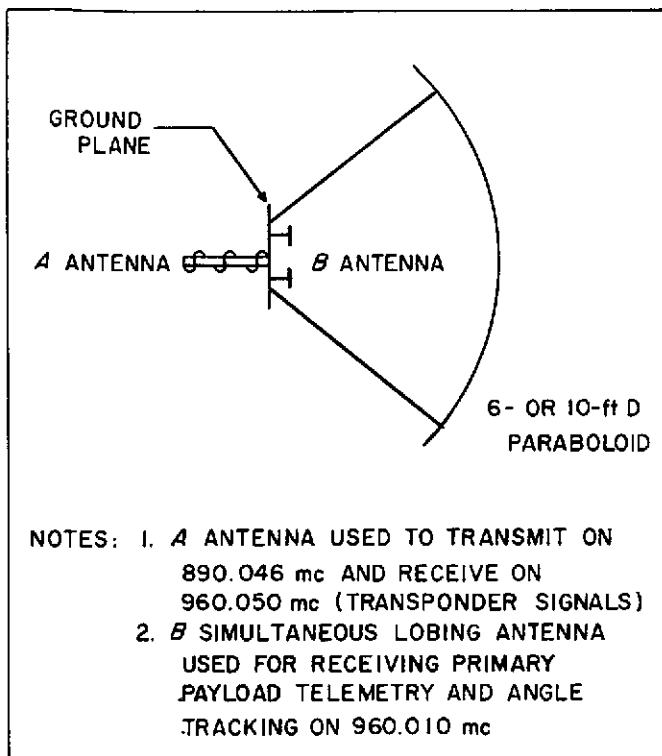

Fig. 22. Antenna Elements of Payload Telemetry and Tracking Ground Station

horizon, at latitudes less than the latitude of the station, and moving at angular rates of less than about 1 deg per sec. Stated differently, the Goldstone station can track most space vehicles having a slant range greater than 300 miles, a local elevation angle of greater than approximately 6 deg, and an azimuth of from 90 to 270 deg from true north. The characteristics of the Woomera station are similar except that the available azimuths are from 90 to 270 deg from true south. The projected station in South Africa would have characteristics similar to the Woomera station.

The stations are primarily designed for the postinjection phase of deep-space flight. In addition, however, a reasonable capability exists for instrumenting such portions of preinjection phases of flight and of instrumenting satellites whose paths lie within the station coverage. The 85-ft-diameter, parabolic-reflector, polar-axis-mounted tracking antennas will be equipped for simultaneous lobing tracking at 960.05 mc and, later, at 108 mc. In the future, the antennas will be able to receive in the frequency band of 225 to 260 mc with standard telemetry receivers. Slant range and velocity of the probe relative to the station may be obtained at the Goldstone site by

means of an 890-mc transmitter in conjunction with a vehicle transponder. One-way doppler may be obtained from the other stations. No transmitting capability has been planned for stations other than Goldstone until at least the first of CY 1961. Earth-to-probe command signals may, therefore, be sent only from the Goldstone station.

The maximum telemetry range of the deep-space net will depend, of course, on the characteristics of the vehicle transmitting system and upon the state of the art of the deep-space net. Through a series of improvements (primarily in the ground receiving system) it is intended to maintain the sensitivity of the deep-space net as close as practicable to the maximum value allowed by the state of the art. It is intended to use both parametric and, later, maser amplifiers. Since the deep-space net is under the technical cognizance of JPL, its capability will be maintained at a level compatible with the practical design constraints of the *Vega* and succeeding vehicles.

Interstation communications for the deep-space net were originally proposed as a private, three-station HF network.² Later, when the net was modified to provide broader program capability (assistance in the meteorological, communications, and man-in-space programs), and when ARPA and NASA were to provide similar stations loosely tied together, JPL recommended that a single agency, the Army Signal Corps, be given the responsibility for providing the required communications to all stations, with ARPA and NASA providing funds and direction. This approach to establishing communications is under consideration by the Space Flight Operations Division of NASA Headquarters, pending a decision on the over-all NASA communications problem. The communications problem is particularly important for the Woomera station because it is used as a part of the launch-to-injection net. The *Vega* third-stage burning occurs in the vicinity of Australia for interplanetary firings. Woomera thus becomes an important down-range instrumentation point for which excellent voice and teletype circuits are mandatory. Figure 24 shows this dependency upon the deep-space communications.

Coordination of the NASA deep-space net with the *Vega* problem is comparatively easily accomplished in the case of Goldstone and, probably, Woomera, since these

²Rechtin, E., *Proposal for Interplanetary Tracking Network*, Publication No. 140. Pasadena, Jet Propulsion Laboratory, July 25, 1958 (Secret).

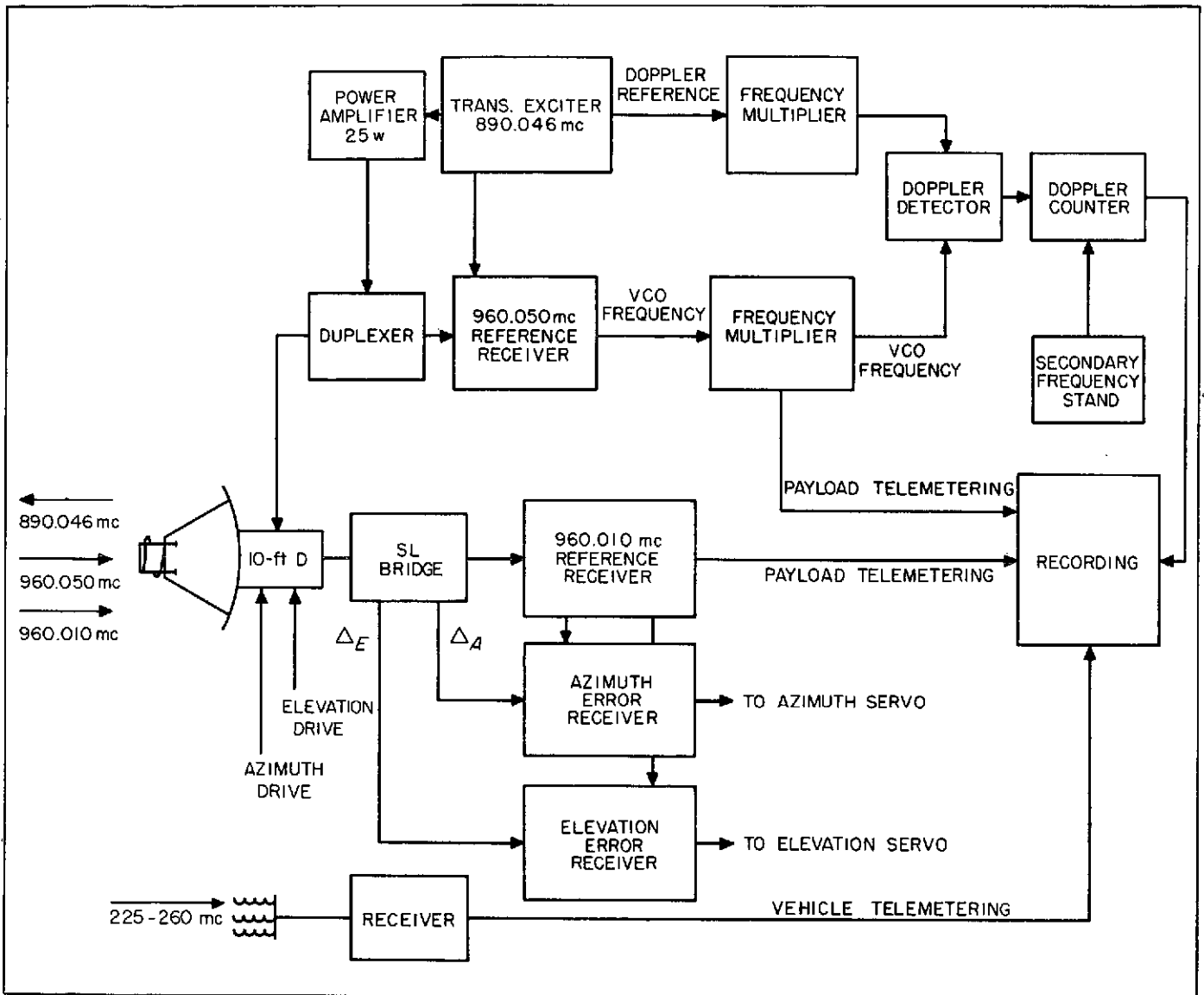

Fig. 23. JPL Down-Range Instrumentation Station

stations are under the technical cognizance of JPL. Coordination with the Spain or Jodrell Bank stations will be more difficult. In brief, the status of the deep-space net is compatible with the status of the Vega program.

Table 6 shows the estimated range of the communications system, assuming adequate funding, normal technological advances, and the following payload capabilities:

Calendar Year	Vehicle Transmitter Power, watt	Vehicle Antenna Gain, db
1959	0.2	0
1960	25	0
1961	25	10
1962	100	20

Table 6. Communication Range Capability Plan for Deep-Space Net

Period	Goldstone		Woomera	
	Receiver	Transmitter	Receiver	Transmitter
1959, first half	operational 1-way system; 10 ⁶ -mi range	construction of transmitter installation	antenna fabrication (U.S.)	
1959, second half	R&D modifications for improved angle accuracy and extended range. operational 1-way system; approx 10 ⁶ mi range		construction of site; fabrication of equipment (U.S.); installation of equipment	
1960, first half	operational 1-way system; R&D modification for 2-way coherent system	operational 10-kw transmitter; R&D modification for 2-way coherent system	construction of site; installation of equipment	installation of equipment
1960, second half	operational 2-way system; range, 10 ⁷ -10 ⁸ mi; R&D	operational 2-way system	system tests and evaluation; operational 1-way, range, 10 ⁷ -10 ⁸ mi	
1961, first half	operational 2-way system; range capability, 10 ⁸ -10 ⁹ mi; R&D for 2-way coherent range	operational 2-way system; R&D for 2-way coherent range	operational 1-way system; installation of equipment for 2-way coherent system; installation of equipment for improved range capability	installation of transmitter and 2-way coherent system equipment
1961, second half	R&D; operational 2-way system with coherent range and velocity	R&D; operational 2-way system with coherent range and velocity	operational 2-way system; range, 10 ⁸ -10 ⁹ mi	operational 2-way system
1962, first half	operational 2-way system with coherent range and velocity; range, 10 ⁸ -10 ⁹ mi; R&D for extended range	operational 2-way coherent system; R&D for extended range and bandwidth	operational 2-way coherent system; installation of equipment for 2-way coherent range and velocity	operational 2-way system; installation of equipment for 2-way coherent range and velocity
1962, second half			operational 2-way system with coherent range and velocity; range, 10 ⁸ -10 ⁹ mi	operational 2-way system with coherent range and velocity

The ranges indicated in Table 6 provide for the transmission and reception of telemetering and command information and range, velocity, and angle determination.

The South Africa station is 1 year behind Woomera in development. However, when activated it will have an equivalent capability.

C. Vehicle Support

The major operations required for support of a *Vega* vehicle from fabrication to firing are shown in Fig. 26. As shown, the GE stage 2 motor is supplied to Convair, San Diego, where stages 1 and 2 are fabricated, assembled, and checked out. JPL, Pasadena, will fabricate and test stage 3 and, in some cases, the payload. In the case of two-stage vehicles, the payload components supplied by other agencies will be integrated by JPL and the payload will move through essentially the same channels shown for the deep-space payload. For the first three vehicles, stage 3 and the payload will be shipped

to Convair, San Diego, for system tests to prove compatibility. Upon completion of system tests, stage 3 and the payload are prepared for shipment to AMR, while stage 2 is shipped to Sycamore Canyon, San Diego, for a flight readiness firing (FRF) prior to being shipped to AMR. Stage 1 will be formally accepted after shipment to AMR, and stage 2 will be accepted at the completion of the flight readiness firing at Sycamore Canyon. At AMR, it is expected that the vehicle stages will be inspected, checked-out separately, and mated for the first time in the launching complex several weeks before firing.

At the firing range, a variety of personnel, facilities, and ground equipment is required in support of the vehicle while the inspection, checkout, preflight preparations, and launching operations are being performed. The personnel required for these operations will be furnished jointly by JPL, Convair, and other agencies, as appropriate.

In direct support of the *Vega* program, the following key facilities are planned for field testing:

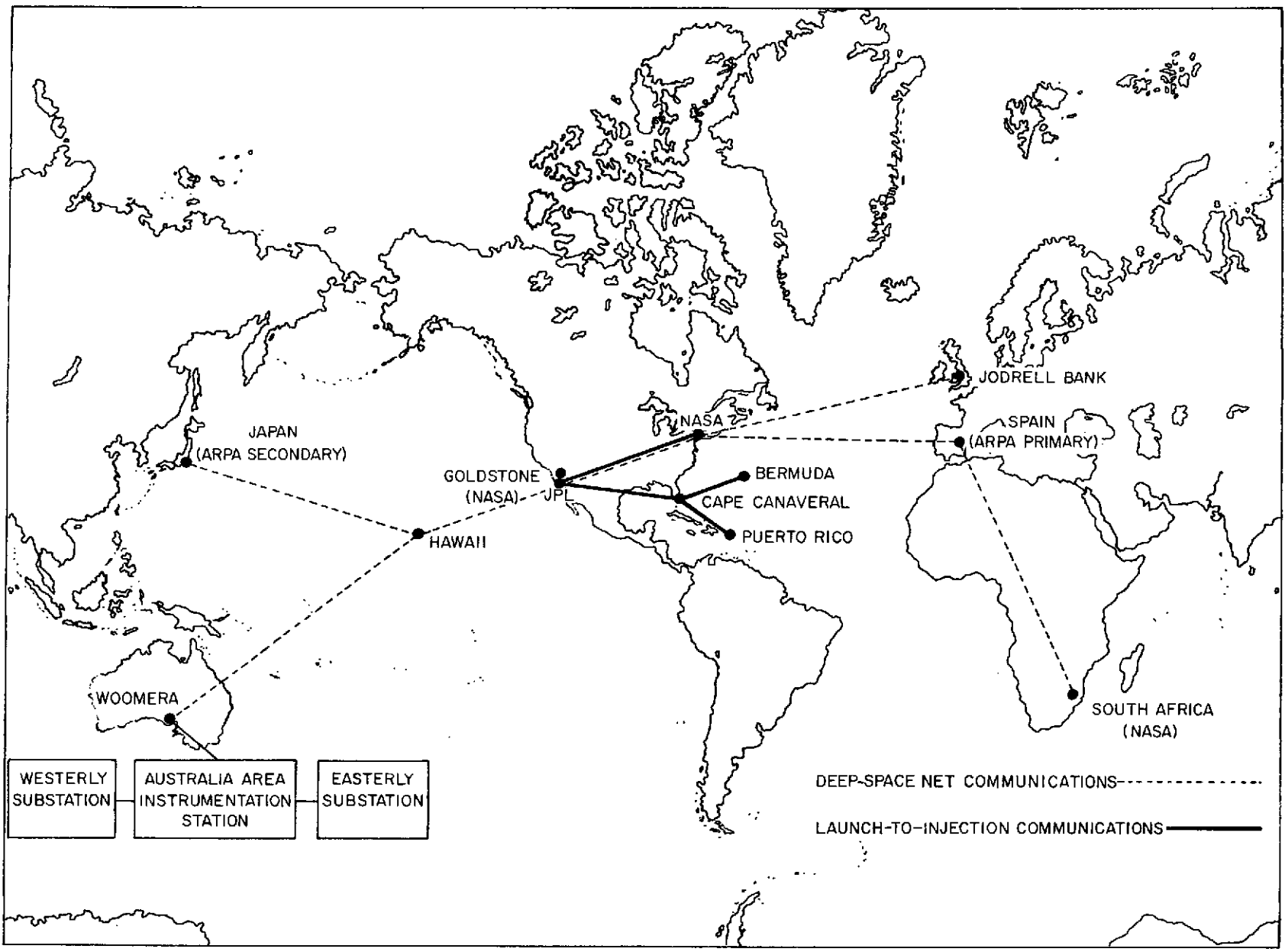

Fig. 24. Communications Net

CONFIDENTIAL

CONFIDENTIAL

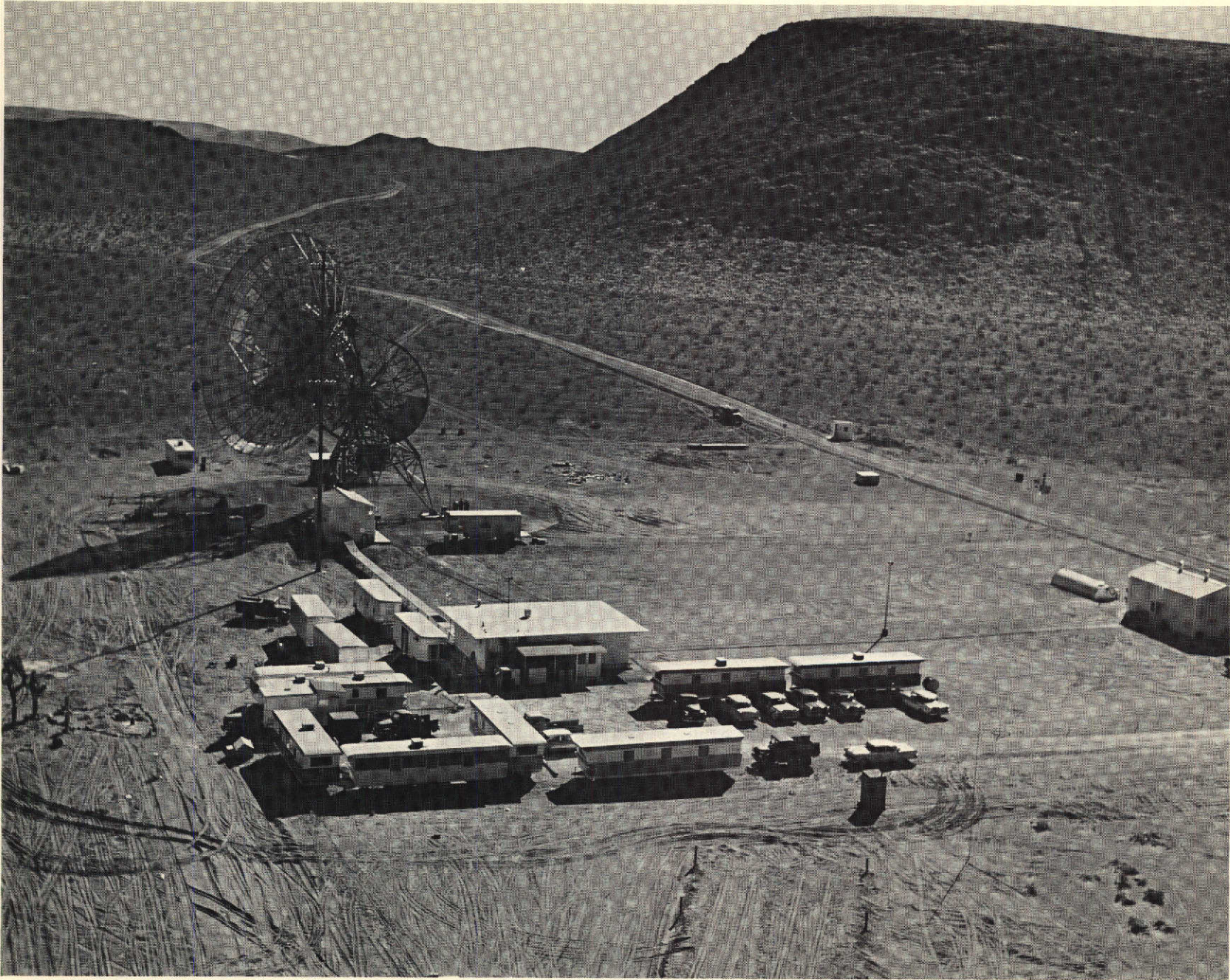

Fig. 25. Goldstone Station as Employed in Tracking Juno II to 407,000 Miles on March 6, 1959

1. A modified *Atlas*-type launching complex at AMR.
2. Approximately 20,000 sq ft of hangar and laboratory space for checking the first and second stages upon arrival at AMR.
3. Approximately 20,000 sq ft of hangar and laboratory space for checking the JPL third stage and spares upon arrival at AMR.
4. Approximately 3000 sq ft for the handling of solid-propellant devices associated with certain missions at AMR.
5. Instrumentation sites for emplacement of launch instrumentation station in the vicinity of the AMR launch site.
6. Alternate sites, at Puerto Rico and Bermuda, for the emplacement of instrumentation stations.

Facilities are planned to house a deep-space net primary station (described in Section IV-B) and, for some trajectories, an instrumentation station for receiving during the third-stage burning period. Additional instrumentation sites are planned in the vicinity of Australia for coverage of third-stage burning periods on other trajectories. Facilities are also planned for a deep-space net primary station in the vicinity of Johannesburg, South Africa.

The ground support equipment (GSE) includes all the numerous electronic and mechanical equipment required for the checkout, handling, and firing of the vehicle. The electronic equipment includes guidance, payload, telemetering checkout trailer, and the blockhouse monitoring and control equipment. The mechanical equipment includes the containers, handling fixtures, transport equipment, propulsion system checkout equipment and consoles, the fuel and oxidizer trailers or systems, metering trailers, pressurization systems, air-conditioning trailers, and monitoring and control equipment. Figure 27 indicates the amounts and types of equipments that will be used in the launching complex and for other field operations.

In cases where portions of the vehicle are changing from round to round, it is desirable and practicable to build a number of mobile sets of related ground support equipment wherein each set is associated with a par-

ticular vehicle early in its assembly and stays with that particular vehicle until it is launched. The advantages of such an approach are:

1. Incompatibilities between the vehicle and the ground support equipment can be detected and corrected before the vehicle goes into the field.
2. Modifications and incompatibility corrections need be accomplished on only one set of ground support equipment.
3. A set of ground support equipment is available for modification without operational conflicts.

As an example, on the basis of a launching every other month, three sets of trailerized test and checkout equipment for the guidance system will be assembled. One set will be undergoing modifications for its particular round while the other two are moving from the JPL assembly building to the field with their particular rounds.

Although it will be duplicated in some trailers, the blockhouse control and monitoring equipment is required for the most part only in the blockhouse. However, it will necessarily undergo modifications as the vehicle changes. This equipment must be supported by assembly and subassembly spares, and modifications must be planned for implementation in a span of one or two weeks.

The three stages of the *Vega* will have various parameters monitored prior to launch so as to determine the readiness of the vehicle for flight. A diagram of the firing area showing mechanization of the ground instrumentation is shown in Fig. 28. The propulsion system monitoring will be necessary in order to detect undesirable conditions such as excessive pressure or temperature buildups, which would endanger both the vehicle and the operating personnel. In addition to propulsion system monitoring, the first and second stages will have parameters monitored from the electrical, guidance, servo, telemetering, range safety, and launcher systems. All measurements will be monitored and recorded in the blockhouse and will be transmitted from the vehicle to the blockhouse through umbilical cables. Typical pre-launch instrumentation for the three stages is listed in Table 7.

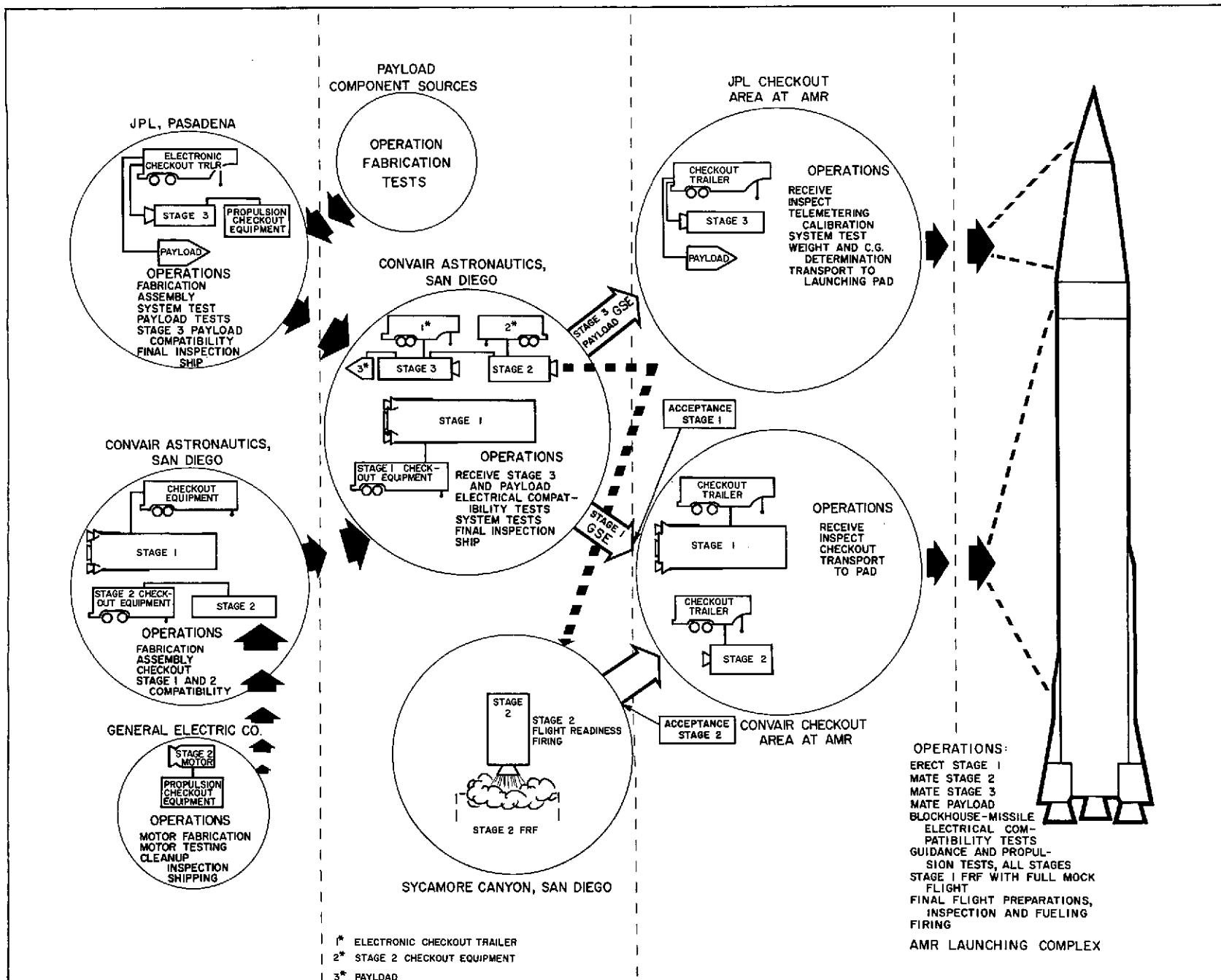
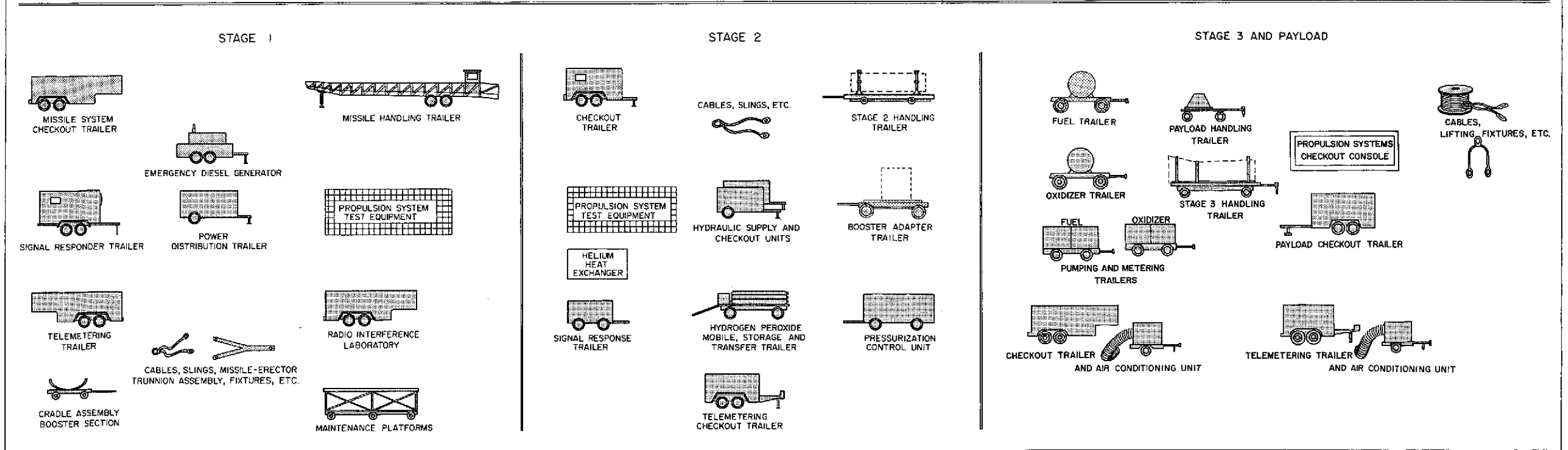
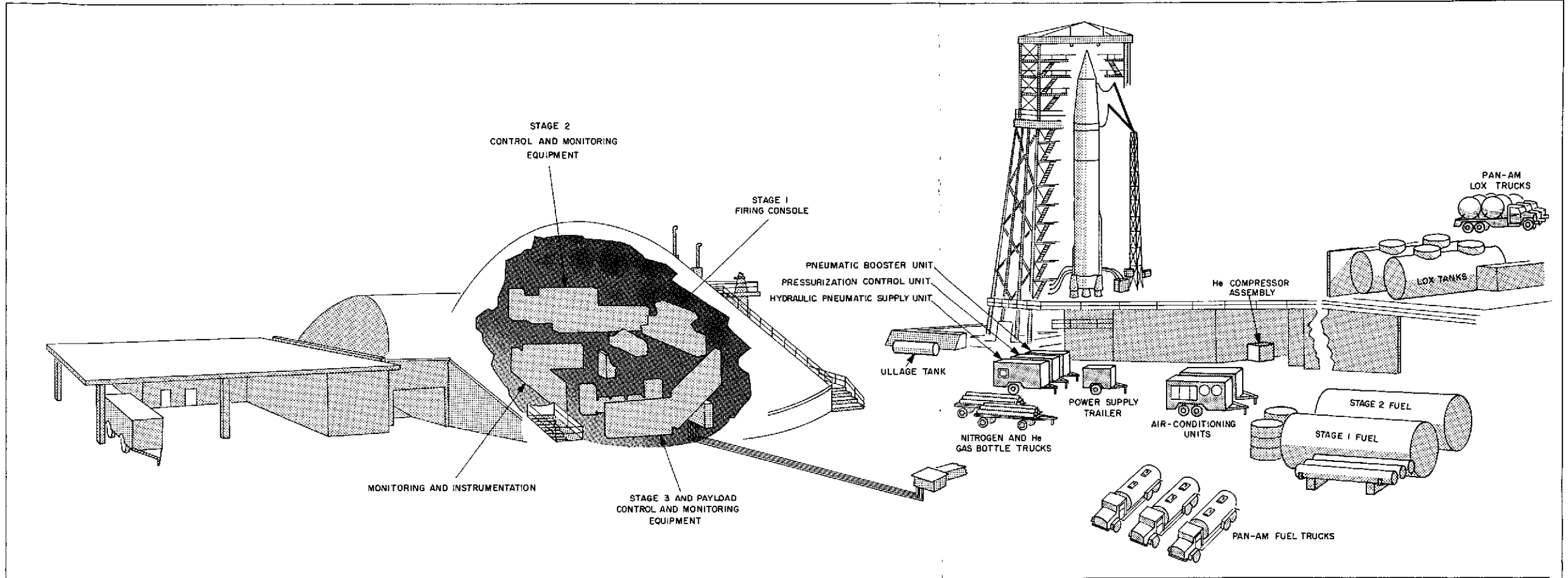

Fig. 26. Major Operations in Support of Vega Vehicle



Preceding page blank

31-A

Fig. 27. Typical Ground Support Equipment for Vega Vehicle

Table 7. Prelaunch Instrumentation List for Vega

Measurement Area	Approximate Number of Measurements		
	First Stage	Second Stage	Third Stage
Propulsion system			
Pressures	9	2	5
Temperatures	6	1	2
Timed Events	0	16	
Miscellaneous	4	0	
Pressurization system			
Pressures	15	3	
Temperatures	5	0	
Electrical system			
Currents	2	0	
Voltages	8	2	
Phase	3	1	
Guidance system			
Voltages	2	0	18
On-off contact	6	0	
Servo system			
Current	1	0	
Voltage	25	5	
Timed events	3	0	
Displacements	0	3	
Telemetry system			
Timed events	2	0	
Range safety			
Timed events	5	0	
Launcher			
Pressures	2	0	

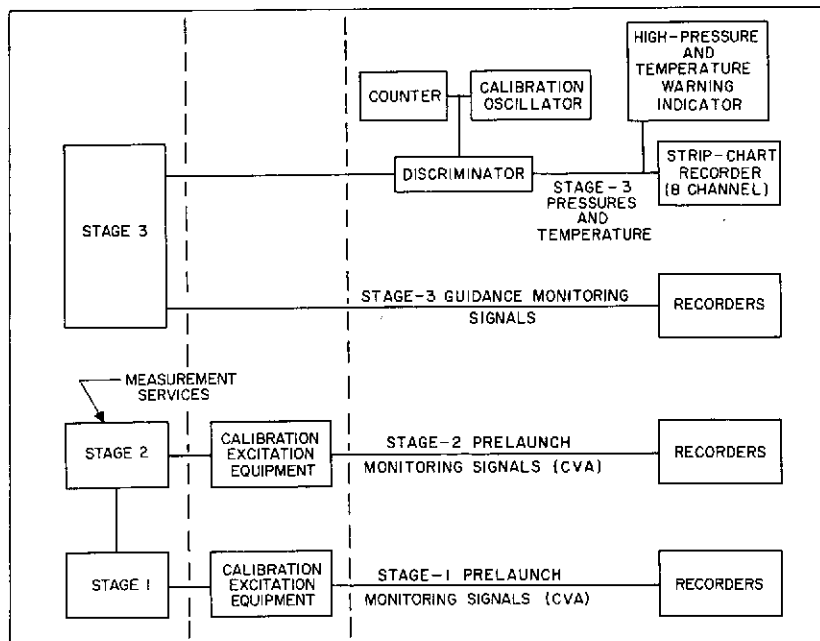

Fig. 28. Ground Monitoring System

V. VEGA PLANNING

A. Scheduling

Initial *Vega* scheduling (see Fig. 29) has been influenced to some extent by the target dates: the first of October, 1960, when Mars is available, and the first of January, 1961, when Venus is available. These planets are again available in December, 1962, and September, 1962, respectively. Although the first few *Vega* launchings will emphasize vehicle and system development, it appears worth while to fire in the direction of the available planets. A launching the first of August, 1960, is scheduled to eliminate as many system problems as possible.

In addition to the specific astronomical dates, a general national feeling of urgency regarding space exploration capabilities lends impetus to the *Vega* development.

A critical item is the construction or modification of a firing complex to meet *Vega* requirements. It does not seem likely that a new complex can be constructed in time to meet early *Vega* firings; therefore, modification of an existing complex is necessary to meet proposed firing dates.

The major areas of vehicle design and fabrication are grouped as follows: first stage, second stage, third stage, vehicle guidance, payloads, and ground support equipment. In general, the design and design verification within each of these areas must be essentially completed by January, 1960, and a supply of equipment must be on hand to support an active flight program. Vehicle field crew requirements, documentation requirements, and deep-space net readiness are shown in Fig. 29 so as to illustrate the overall program. Significant events in preparing a *Vega* vehicle for launching are shown on the *Vega* vehicle flight preparation schedule (Fig. 30). The first eight rounds are scheduled. In general, the chart reads in chronological order from top to bottom. The early events listed at the top of the chart are definition of payload objectives, telemetry assignment complete, and preliminary flight test directive delivered. The remainder of the chart could be considered three separate schedules: schedule of third stage and/or payload at JPL, schedule of second stage at CV-A, and AMR operations. Interrelationships between the schedules are shown by dotted lines.

Some significant points brought out by this schedule are:

1. Firing crews will be occupied full time with operations.
2. It is apparent that the firing rate cannot be increased over that indicated without overlapping operations from round to round to such an extent that duplication of factory and launching facilities and personnel will be required.
3. Any major slippage in the schedule will very seriously disrupt the scheduling of subsequent rounds.
4. Early delivery of all flight-ready equipment is indicated because of system operational requirements. As an example, deliveries to the JPL assembly building of all payload and third-stage equipment must occur as follows:

Vehicle	Delivery Date, 1960
1	Feb 15
2	May 7
3	Aug 1
4	Oct 21
5	Dec 21

B. Reliability

Throughout the *Vega* program, reliability will be attained by means of a verified safety margin technique. In this technique, a design is created based on extensive engineering experience and then is proven adequate. This will be accomplished by means of comprehensive and integrated laboratory and use test programs wherein the equipment is shown to operate satisfactorily under environmental conditions, both natural and induced, at levels significantly in excess of the expected use levels. In support of these efforts, all critical environments will be actively studied and evaluated, the objective being a detailed functional environmental test specification and test procedure for all types of equipment. This specification will be entirely compatible with equipment performance requirements and environmental testing capabilities and will result in a consistent engineering development and design verification effort.

The environments associated with the *Vega* vehicle can be divided into two areas, the handling and ambient conditions encountered prior to launch, and the launching environment.

The following environmental figures are estimates for typical electronic equipment locations. (Under certain circumstances and in certain locations, conditions encountered throughout the three-stage vehicle may vary as much as an order of magnitude, both in character and severity, from these estimated values.) The handling and ambient conditions include the usual shock ($36g$ drop) and vibration (4 g to 500 cps), humidity (100%), rain (1 in. per hr), sand and dust, temperature (125°F). The launching environment includes aerodynamic and engine burning vibration (0.025 g^2 /cps, 20-1500-cps band +6 g rms sine wave), shock (50 g), and static acceleration (8 g).

C. Payload Integration

Since the *Vega* program is designed to yield new knowledge both in space technology and in space science, it is to be expected that there will be considerable variety in the experiments flown. Therefore, the payload equipment development and payload vehicle design will be subject to change as the program advances. It is desirable, then, to make the launching vehicle system, including the payloads, as flexible as possible. For example, the rocket may be used either as a two-stage earth satellite vehicle or as a three-stage interplanetary vehicle.

When the problem of integrating the payload with the vehicle and the rest of the system is examined in more detail, additional requirements are indicated. The complete system must be designed with the over-all payload requirements in mind, just as in the case of the propulsion and structure integration. For example, every mission requires some form of communication. (In the case of the so-called passive reflecting satellite, the radio and/or optical equipment is on the ground, but the requirement still exists.) Second, most missions require attitude control of all or part of the payload vehicle. The earth-satellite payload capacity of the *Vega* vehicle is large enough to permit the carrying of optical telescopes, spectrometers, high-resolution television equipment, controllable re-entry vehicles, and other such devices, all of which require attitude stabilization and control. For interplanetary missions, attitude control is

necessary to permit the use of high-gain communication antennas, minimum-weight solar-power panels, target-seeking scientific equipment, and maneuvering rockets. In order best to accomplish the detailed design of the payloads, they should be designed as entities after compatibility with the system criteria is established.

In order to satisfy these criteria, it is often desirable to separate the payload vehicle from the spent final-stage rocket after injection. Before flight, the payload and the launching vehicle follow different time schedules, pass through different types of tests, and require decisions by different personnel. Therefore, the concept of a separable payload package is useful. The basic payload vehicle thus indicated contains the power, attitude control, and communication functions characteristic of the type of mission (satellite, lunar, or interplanetary), with scientific equipment for different specific missions (e.g., Mars or Venus) accommodated by moderate changes in the basic design. The basic equipment would gain in reliability through repetitive use.

A single payload vehicle may often contain several independent unrelated experiments such as the cosmic ray and micrometeorite experiments in the *Explorers*. Making certain that these equipments are compatible with each other and with the carrier vehicle is expected to consume a substantial portion of the payload engineering effort for the *Vega* program.

D. Growth and Improvement

Growth potential, although not a primary objective, has been given some attention in the design of the *Vega* vehicle. Several different kinds of improvement may be available in later phases of the program. The payload weight can certainly be increased, perhaps doubled, for typical interplanetary missions. Launch-on-time and in-flight reliability growth are primarily obtained by experience; and the development of experience applicable to future vehicles has had an important bearing on NASA decisions such as the selection of the *Centaur* modification of the *Atlas* booster and the GE 405H-2 engine and on JPL decisions such as the choice of the *Vega* inertial guidance components.

Growth also may take place in the direction of flexibility. The 10-ft-diameter, pressure-stabilized tanks of the *Vega* second stage constitute an advanced type of structure that can readily be modified to support different

types of large-diameter satellite payloads. The coasting and restart capacity of the second stage and a possible similar capacity in the third stage may be used for various special missions.

Some means available for increasing the payload weight are given as follows:

1. Higher gross weight on *Atlas*. As explained previously, propulsion details and tank loads now limit *Atlas* load-carrying capacity to about 32,000 lb; the upper-stage tanks are sized to permit growth to 35,000 lb. With *Atlas* propulsion and structural modifications, the upper-stage weight can be further increased, perhaps ultimately doubled, before the basic thrust limit of the booster engines is reached.
2. Lower empty weight of third stage. Since the third stage uses a new power plant, a conservative approach is being taken initially in some areas. One of the main advantages of the hydrazine fuel is that it is an excellent gas generant. A change from the present cold-helium pressurization scheme to a hybrid scheme of hydrazine gas generation would increase the interplanetary payload by 100 to 150 lb. This change may be introduced relatively early, since the gas-generation system has been under development for several years at JPL. The present

6K thrust chamber is a conservative design. Experimental engines already tested at JPL show promise of an ultimate weight saving of as much as 50 lb.

3. Lower propellant residuals. As experience is gained with the vehicle, a substantial payload increase will certainly be achieved through the reduction of residual propellant allowances, with increased reliance on propellant utilization systems in the first and second stages. The payload gain can amount to 100 lb or more.
4. Higher specific impulse in second stage. The use of a *Centaur* stage for the *Vega* second stage is a possibility for later phases of the program. At present there is no accurate estimate of the effect on payload.
5. More accurate guidance and improved communication equipment. As explained previously, on interplanetary missions there is a tradeoff between gross payload weight and flight time; flight time in turn is related to the required guidance accuracy and communication distance. Thus, improvements in these areas which permit the use of more nearly minimum-energy transfer paths can have as great an effect on the net weight available for scientific payload equipment as any of the propulsion and structural improvements discussed above.

VI. PROGRAM ORGANIZATION

NASA has the over-all *Vega* program responsibility and has designated JPL to provide the technical direction of the program.

Excluding the development of the JPL 6K stage and the various payload designs, there are two contracts covering the development of new hardware specifically designed as elements for the *Vega* vehicle: Contract NASw-30, covering the GE 405H-2 engine, and Contract NASw-45, covering the CV-A second-stage effort. The first-stage modification design is estimated to be 95% common with *Centaur* requirements and is to be covered in the ARPA-CV-A *Centaur* contract. Technical direction of the NASw-30 contract for the GE 405H-2 engine is being handled by NASA headquarters, with JPL performing coordinating liaison.

The various areas of effort constituting the over-all *Vega* program fall roughly into the following categories:
JPL:

- Technical direction
- Third stage
- Guidance
- Deep-space payloads
- Deep-space net

NASA Headquarters-CV-A Contract NASw-45

- Second stage
- Forward shroud (not initially provided in contract)
- First- and second-stage field activities.

Associated Items and GFE Handled through Air Force Ballistic Missile Division (AFBMD):

- Atlas* booster (modifications are incorporated in basic fabrication)

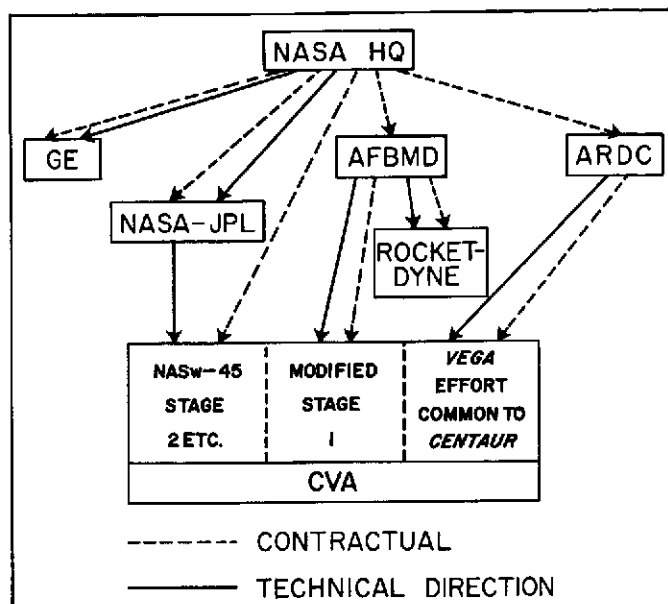

Fig. 31. Major Contractual and Technical Direction Channels for the *Vega* Program

- Rocketdyne engines
- Azusa transponder
- Rocketdyne AMR representatives
- Atlas* ground support equipment

Miscellaneous Items

- GE 405H-2 engine (NASA Headquarters-GE Contract NASw-30)
- Satellite payloads (by various agencies)
- Propellants
- AMR launching complex and facilities

Figure 31 shows the major contractual and technical channels of the *Vega* program.

APPENDIX

Deep-Space Exploration

1. Missions

The *Vega* vehicle, which can launch instrumented payloads of several hundred pounds onto interplanetary trajectories, will be used for the first phases of the exploration program of the moon, the planets, and interplanetary space. The following paragraphs describe some of the experimental objectives of that program.

Lunar studies. The study of the moon will be directed toward improving the present understanding of the origin and structure of the moon. Knowledge of lunar structure would permit far-reaching deductions as to the origin of the solar system.

Understanding the structure of the moon requires several types of measurements. For example, it will be necessary to determine whether or not the moon has a magnetic field and, if it has, to measure the properties of this field. The atmosphere of the moon is extremely tenuous and would be considered a very rare vacuum when compared with the atmosphere at the surface of the earth. However, it is probable that some traces of atmosphere do exist. The gases that comprise this atmosphere have come and are now coming from the material of the moon itself. It will be necessary to measure both the density and the composition of this rare atmosphere.

It will also be necessary to provide a detailed map of the whole lunar surface. Only by examining the vital details of the surface can the many ambiguities of the moon's surface features be resolved.

The properties of the surface must be measured at first hand, initially by instruments and later by exploration parties. It is necessary to determine the chemical and mineralogical nature of the surface rock in order to deduce the history of the surface. The understanding gained by examination of surface material of the moon must be extended by measurements of the internal properties. It is necessary to determine whether or not the moon has a core, or whether or not it exhibits any sort of stratified interior structure.

In order to carry out these measurements, it will be necessary to examine the surface optically, from above, with vehicles which pass by or, when possible, orbit

around the moon. Automatic measuring devices must be landed on the surface. Some such devices can withstand the impact of an uncontrolled landing; others will require a braking rocket to bring them down more gently onto the surface. The soft landing of a sizable instrument package will probably require a launching vehicle larger than the *Vega*.

Study of the planets. The objectives involved in the study of the planets are similar in many ways to those involved in the study of the moon. Although the surfaces of the planets will not reveal as much of the early history of the solar system as will the surface of the moon, a study of the interior structures of these larger bodies may enlarge our knowledge of the solar system. Furthermore, the exploration of the planets offers us a highly intriguing possibility which the exploration of the moon does not. The nearby planets have atmospheres. The atmosphere of Venus is probably much more dense at its surface than is the atmosphere of earth; whereas the atmosphere of Mars is apparently about one-tenth the pressure of earth's atmosphere at the surface.

Because of the existence of atmospheres and the resultant possibility that liquids such as water are present, there is a real possibility that some form of life may exist on Mars and Venus; Mars is the more likely prospect, since the surface of Venus is apparently quite hot.

At the present time, there can be only speculation as to whether or not the earth is unique in the origination of life. If there can be discovered one other body, remote from the earth, upon which life exists, then immediately the whole universe is populated. For there is little question but that out of the millions of stars quite similar to our own sun there are many other planetary systems. The most likely cosmological theories would make it almost inevitable that systems of planets would be formed in conjunction with the formation of a star. But the theory of the inevitability of life is much more speculative. Thus, the question of the existence of life becomes of utmost importance in a study of the planets.

Like the study of the moon, a complete study of a planet will require a measurement of its magnetic field

(if one exists), measurements of the density, composition, and structure of its atmosphere, and an accurate map of its surface. Surface measurements will include chemical and mineralogical analyses of surface material as well as a probing by coring and seismography into the planetary interior. And, of course, surface exploration must be aimed toward the discovery and analysis of life forms.

Planetary exploration will be initiated with vehicles which pass by the planets and continue on into space. These initial probes will be followed by payloads designed to be brought into an orbit around the planet. Both such payloads will conduct measurements of the magnetic field and detect the existence of any trapped bands of cosmic radiation such as have recently been discovered around the earth. The payloads will also be equipped with television-type instrumentation which will provide increasingly detailed maps of the planet surface. Such payloads can be launched with the *Vega* vehicle.

Landing on a planetary surface presents problems different from landing on the surface of the moon. Planetary atmosphere both helps and hinders a successful landing. It helps by making possible the use of aerodynamic braking instead of retrograde rockets. On the other hand, it will cause aerodynamic heating of the probe which enters it at extreme velocity. Successful landings on planet surfaces will derive from the technology developed to permit the design of a successful re-entry warhead on an ICBM. Some of the initial experiments which penetrate planetary atmospheres can be launched with the *Vega*.

The sun. Interplanetary space is filled with interesting and important phenomena. Many of these phenomena find their origin in the behavior of the sun. Others are the result of occurrences in our galaxy or in the other galaxies of the universe.

The surface of the sun is in constant turmoil. Flaming streamers shoot out hundreds of thousands of miles into space. It is marked periodically by groups of turbulent sun spots.

The sun gives off not only the light which is seen here, but also radiations in frequency regions filtered out by the earth's atmosphere. The sun also ejects a continuous stream of atomic particles. It is suggested that these particles are responsible for the radiation bands surrounding the earth. A complete picture of solar activity and an understanding of the solar energy cycle can be gained only by a thorough investigation of all of the

material and radiation ejected from the sun. However, due to the atmosphere there is no opportunity to make such observations from the surface of the earth.

Above the atmosphere, in a satellite circling the earth, the complete spectrum of solar radiation can be inspected. From a probe traveling through space, either in toward the sun or out away from it, the nature and distribution of atomic particles ejected from the sun can be measured. In addition, it is important to determine the differences between the material which is ejected into the plane of the ecliptic (the plane which contains the earth's orbit and from which the orbits of the other planets differ only slightly) and the material which is ejected in other directions from the sun.

Other experiments. In addition to the purely scientific measurements to be carried out in interplanetary space, it will be necessary to perform many missions directed toward technological advancement. As the vehicles to conduct the program of space exploration are developed, many of the measurements taken during flight will relate to the behavior of the vehicles themselves. Only in this way can the necessary data be obtained for continuing improvements in guidance, communications, propulsion systems, and general system design.

Furthermore, there will be a continuing need for engineering design data. Space environment is completely new. If vehicles are to be designed which will carry men and equipment to the planets, a building up of a background of information on the behavior of materials and equipment in this new environment must begin. Thus, there will be a continuing and growing need for technical data which will enable the undertaking of successful, manned space flight.

A list of appropriate missions for the initial *Vega* program is shown in Table A-1, which relates the capabilities of the *Vega* system to the problems discussed briefly in the preceding material.

2. Payload Guidance

For advanced lunar and interplanetary missions, post-injection (payload) guidance will be necessary. Apart from any retrorocket phase, this guidance will take the form of (1) mid-course guidance either by an earth-based radio-command system or by a self-contained celestial navigator, or both, and (2) terminal guidance by a self-

Table A-1. Deep-Space Missions of Vega Payloads

Mission	Date	Objective	Possible Measurements
1	Aug, 1960	escape—lunar near miss	spectrophotometer, vidicon photography, cosmic ray and solar corpuscular radiation, magnetic fields, micrometeorite and meteor detectors,
2	Oct, 1960	escape toward Mars	infrared spectrophotometer
3	Jan, 1961	escape toward Venus	(same as 1)
4	Mar, 1961	earth satellite	meteorological observations
5	May, 1961	earth satellite	communications, active relay station, or passive balloon reflectors
6	July, 1961	lunar satellite	vidicon mapping (various resolutions and area coverages), radar altimeter
7	Sept, 1961	earth satellite	meteorological observations
8	Nov, 1961	lunar satellite	gamma ray spectrograph, magnetic field, mass spectrograph, cosmic ray, solar corpuscular radiation

contained system employing sighting (probably infrared) on the target planet. The kind of payload guidance expected for various possible space missions is shown in Table A-2.

Table A-2. Expected Payload Guidance for Space Missions

Possible Space Missions	Radio-Command Mid-Course Guidance	Self-Contained Terminal Guidance	Self-Contained Mid-Course Guidance (celestial navigator)	Lunar Landing Guidance (Radar and Infrared)	Retrorocket Firing
Mars/Venus approach within 30,000 mi	X				
Lunar satellite (300-mi altitude)	X				X
Lunar soft-landing (within 50-mi-diameter circle at less than 30 ft/sec)	X			X	X
Mars/Venus satellite (1000-mi altitude)	X	X			X
Mars/Venus atmospheric entry	X	X			
Advanced interplanetary missions, e.g., return trip to Mars	X	X	X		X

It will be seen from Table A-2 that radio-command mid-course guidance is expected to play a major role in Vega payloads. Such guidance will take the form of a small rocket (e.g., 5% of the payload) fired on ground command within a few days after injection. Prior to firing, the vehicle will also be commanded to roll about a given axis, probably that of a directional antenna pointing at earth. Three-axis attitude control is therefore necessary, not only for orienting the rocket, but for stabilizing the thrust vector during burning. Because the magnitude and direction of the correction will be computed by radio tracking, the design and performance of this mid-course guidance system is intimately related to capabilities of the deep-space net and the associated computers. In the first three payloads, there will be no mid-course guidance, only a mid-course guidance experiment, since the rocket will be fired in a fixed direction along the sun-probe line. There should be the capability for radio-command mid-course guidance for Vega payloads in mid-1961.

For the tentatively planned missions to Mars and Venus in late 1962, self-contained terminal guidance must be developed. This will involve one (and possibly two) lateral maneuvers probably based only on angular sightings of the destination planet relative to stars, plus a determination of range from the angular diameter. Because of the crescent phases of Venus, infrared techniques (4 to 5 microns) are indicated. Passive experiments on celestial navigators (self-contained mid-course guidance) could also be carried in these 1962 payloads.

3. Payload Power Sources

Analysis of space power systems reveals two major technical subdivisions: power sources and power conversion.

For most space missions, the operating times are so long that radiant power converters and nuclear power sources are much lighter in weight than conventional chemical and electrochemical energy sources. Conventional energy storage systems, such as electrochemical batteries, fuel cells, or chemical propellants, become excessively heavy as the operating times exceed 50 hr. The weight of chemical energy sources increases directly with the product of power level and operating time.

The following tabulation shows the estimated watt/lb performance of the various power systems, based on a 50-hr operating time.

CONFIDENTIAL

Electrochemical batteries and fuel cell systems	1.0 to 3.5 watt/lb
Solar cells at earth.	5.0 to 12.0 (no protective cover)
Radioisotope thermionic diodes	8.0 to 15.0 (1 to 100 watts)
Radioisotope thermoelectric semiconductors	5.0 to 15.0 (1 watt to 1 kw)
Nuclear reactor-turbo-alternator.	6.7 at 3 kw 11.3 at 10 kw 20.0 at 30 kw

For radiation power converters (solar cells) and nuclear power sources and converters (radioisotope thermionic diodes and reactor-turbo-alternators), weight increases as a function of power level only. This "power level only" factor gives solar and nuclear power so great a weight advantage for space probes that they are the sources most worthy of intensive effort for future space probe applications. Power sources such as solar and nuclear converters can provide continuous power for an indefinite period, whereas other energy sources possess a fixed watt-hr capability.

Energy conversion control involves voltage and frequency reference elements, servo amplifiers, and actuators for positioning such equipment as solar cell panels. Great emphasis must be placed on reliability and simplicity for such devices in order to make them useful. The weight of the control and electrical power conversion devices associated with the various energy sources is generally overshadowed by the dominating watt-hr power requirement.

The preliminary studies and JPL's experience in the fabrication of early satellites have clearly demonstrated the necessity for close integration of the space power system with the payload. The interrelated positioning problems of solar cells, the communications antenna, and the optical devices used in mid-course and terminal guidance are typical.

A preliminary estimate of power requirements for possible *Vega* missions is shown in Table A-3. The estimated space probe power requirements and operating times vary from 200 to 600 watts and from 40 hr to 8 months.

In general, the space probe power systems will utilize solar and nuclear power converters, with a minimum amount of electrochemical energy storage to deliver relatively high-power pulses that are no longer than a few

Table A-3. Power Requirements Estimate for Deep-Space Missions

Mission	Duration of Experiment	Average Power watts
Escape—lunar near miss	40 hr	200
Escape toward Mars	6 mo	200
Escape toward Venus	6 mo	200
Lunar satellite	1 mo	200
Venus satellite	2-8 mo	600
Venus entry	2-6 mo	200
Mars near miss	6 mo	200
Circumlunar and return	—	200
Lunar soft landing	1 mo	600
Venus landing	1 mo	600
Circumlunar and return	—	—
Circum-Mars and return	—	—

hours. Static transistor-magnetic voltage and frequency converters will convert the solar and nuclear generated dc power to regulated dc and ac power.

The characteristics of the various power sources considered for space probes are tabulated in Table A-4. Only solar and nuclear power converters are competitive for operating times in excess of 50 hr.

For the power levels required for the NASA space missions (up to 400 watts for 8 months) solar cells and radioisotope thermoelectric converters are most attractive and are being actively developed. Radioisotopes are not currently available in the quantities required to generate the power needed for the NASA space missions.

The cost of solar cells (\$350/watt, for cells only) and of radioisotopes (\$4500/watt at Mars, 200 days decay for cerium 144) is so large that it has an appreciable effect on budgeting. Only nuclear power sources are competitive in watt/lb for solar system missions to Jupiter and beyond.

4. Attitude Control

Attitude control refers to sensing and control of the angular orientation of the payload as may be required for obtaining scientific or other data, for maneuvering, for radio communication, for guidance measurements, or for the requirements of solar batteries. Attitude sensing may be done by radio or optical means, with assistance from inertial devices. Attitude control may be effected by

CONFIDENTIAL

Table A-4. Characteristics of Power Sources

Power Source	Power or Energy /Weight	Reliability	Availability	Minimum Size and Power Levels	Storage and Longevity	Operational Difficulties
Batteries	80 watt-hr/lb (present); 95 watt-hr/lb (3 yr); 95 watt-hr/lb (10 yr).	high	now	none	silver zinc stand time varies from hr to days; dry cell stand time greater than 1 yr	minor
Fuel cells	dependent on power level and operation time 700 watt-hr/lb max. (at 10-kw rating) at present; 900 watt-hr/lb max. (at 10-kw rating) in 10 yr.	undetermined; no anticipated difficulties	now, on special order	approx. 10 w	indefinite	high temperature, pressure operation; gravity load necessary; fuel evaporation
Isotope-thermocouple	1 watt/lb at present (10 w); 3.7 watt/lb in 3 yr (1 kw); 7.75 watt/lb in 10 yr (1 kw).	undetermined; thermocouple junction difficulty	now in sizes 1 watt; up to 10 kw in 10 yr	none	depends on isotope life	small amount of nuclear radiation; heat radiator required in large sizes
Isotope-turbine	3.8 watt/lb in 3 yr (1 kw); 9.8 watt/lb in 10 yr (1 kw).	being determined	1 kw in 3 yrs; up to 10 kw in 10 yr	approx. 1 kw	depends on isotope life	small amount of nuclear radiation; heat radiator required in large sizes
Isotope-thermo-electron engine	22 watt/lb	undetermined; no anticipated difficulty	units of 100 w to 1 kw after 3 yr	approx. 100 w	depends on isotope life and life of emitting material	small amount of nuclear radiation; heat radiator required in large sizes
Reactor-thermocouple	4 watt/lb in 3 yr (1 kw); 9 watt/lb in 10 yr (10 kw).	undetermined; thermocouple junction	reactor in 3 years; thermocouple now	approx. 1 kw	dependent on reactor life; 1-yr life in 3 yr	large amount of nuclear radiation; large heat radiator required
Reactor-turbine	6.7 watt/lb in 3 yr (3 kw); 13.5 watt/lb in 10 yr (10 kw).	being determined	entire unit in 3 yr	approx. 1 kw	dependent on reactor life; 1-yr life in 3 yr	large amount of nuclear radiation; large heat radiator required
Solar cells (Mars)	6.6 watt/lb in 1 yr; 11.5 watt/lb in 3 yr; 32 watt/lb in 10 yr.	high on basis of existing system performance	cells now; mechanical structures undeveloped	none	unlimited	needs orientation, large collector surface
(Earth)	11.5 watt/lb in 1 yr; 21 watt/lb in 3 yr; 63 watt/lb in 10 yr.					

torquing the vehicle by means of reaction jets or by flywheels. If the required interval of operation is long, both jets and flywheels may be used—the flywheels for continuous use, and the jets for discharging accumulated angular momentum. If the vehicle is near a gravitational center, the gravitational gradient, i.e., the difference in attraction between the ends of the vehicle near to and remote from the gravitational center, can be used to assist in sensing and/or controlling the attitude. Most earth satellites require that one axis of the vehicle point at the center of the earth and that a second axis lie perpen-

dicular to the plane of motion of the vehicle; this condition can be achieved by use of infrared or radiometric horizon seekers together with a gyroscope operating as a gyrocompass. Deep-space probes may require that a medium-gain antenna on the vehicle be pointed at the earth to an accuracy of 2 deg or less; for such control, the earth could be tracked optically or by means of infrared radiation, or the vehicle could track radio signals sent to it from earth.

The attitude control system for the early *Vega* deep-space payloads is one that permits the development of

basic techniques of payload attitude control with minimal sophistication. This system points a given vehicle axis toward the sun throughout the flight. To point a vehicle axis at the sun requires control torques about two vehicle axes. Position information is provided by a combination of solar-cells and knife-edge shades. Rate-measuring devices may also be used. Control of the vehicle rotation about the sun-probe line is based on rate information derived from a gyroscope or other instrument. Actuators for each axis will be small gas jets. The communication system will utilize an antenna axially symmetric about the sun-probe line. Trajectory studies show that the angle between the earth-probe line and the antenna axis does not exceed about 35 deg for a typical trajectory.

Systems for later payloads point a vehicle axis coincident with the antenna axis toward the earth and align another vehicle direction toward the sun. The payload configuration will be chosen to ease the problem of solar power extraction and may include solar cell panels hinged with respect to the payload structure and antenna. The sensors for solar directional control will be of the same type as described for the early payloads. Angular reference information for alignment of the antenna axis will be derived from optical devices and/or the communications system. Provisions will also be made for a programmed rotation prior to a mid-course trajectory-correction maneuver, control of the attitude during the maneuver, and reacquisition, if necessary, of reference directions following the maneuver.

The principal disturbances for which the control system must provide correction are (1) initial angular velocities existing at payload separation, (2) micrometeorite impacts, (3) solar pressure unbalance torques, and (4) misalignment torques produced by the course correction maneuver. Table A-5 shows the magnitude, duration and total impulse requirements for control of these disturbances for a 750-lb payload over a 150-day trajectory.

Calculations have been made on a cold-gas actuator system employing six gas jets mounted on the periphery of the payload for control by mass expulsion. The weight of nitrogen carried at takeoff is less than 2 lb and represents a total actuator system weight in the neighborhood of 15 lb. The system employs a two-level limit cycle operation having rate sensors energized during the high-level mode. Additional gas consumption for the limit cycle operation is approximately 0.2 lb for 1 deg/hr rate sensor

performance and increases as the square of the sensor uncertainty for poorer performance units. In normal low-level operation, the payload oscillates within a 2-deg dead band at a rate of 1 deg/hr. External disturbances of sufficient magnitude cause the system to switch to the high-level rate-controlled mode, wherein control torque is applied to again minimize the error rate signal within the dead band.

Table A-5. Requirements for Control of Vehicle Disturbances

Disturbance	Magnitude per Axis	Duration	Total Impulse, Three Axes
Initial velocities	0.05 rad/sec	—	40 ft-lb-sec
Micrometeorite impacts	5×10^{-3} rad/sec	—	0 ft-lb-sec
Solar radiation pressure	7×10^{-6} ft-lb	10 ⁷ sec	140 ft-lb-sec
Course correction maneuver torque	0.025 ft-lb	100 sec	7.5 ft-lb-sec

Error detection about the sun-probe line is accomplished by means of a four-quadrant vignette type of passive optical sensor. Units under test in the laboratory have demonstrated uncertainty levels below 0.1 deg, with sensitivities exceeding 20 volt/deg. Sensing of rate about the reference axes to the required threshold is a more difficult task in the light of long-term operational requirements. Although modified floated rate gyroscopes are receiving top consideration, developments indicate that passive optical rate generators may become available in time for initial *Vega* flights.

5. Payload Propulsion

Several of the expected missions in the deep-space program present requirements for acceleration of the payload vehicle after injection. For example, one method of obtaining an accurate transfer path is to track the vehicle for several days after injection, compute the trajectory, and command a correcting impulse. In the neighborhood of target bodies, the need for payload propulsion is obvious; substantial speed increments are required to establish satellite orbits or to control entry into an atmosphere. Small liquid and solid rockets that have been built at JPL for possible use in payload vehicles are shown in Figs. A-1 and A-2. The payload vehicle development must ordinarily be conducted on a shorter lead-time basis than

the development of the launching vehicle, because performance and mission requirements cannot be made firm until the vehicle design is fairly well established. Therefore, it is reasonable to develop a capability for designing and qualifying small special rockets in a short time period. The rockets illustrated in Figs. A-1 and A-2 are examples of this technique.

In the *Vega* program, payload could remain attached to the third stage thrust unit and a restart of the 6K engine could supply the correcting impulse. However, this would introduce unwarranted complications in both the 6K stage and payload designs. Also, the speed increment required for the interplanetary trajectory correction is quite small, corresponding to the expenditure of perhaps 20 lb of propellant for a 500-lb payload vehicle. On later larger vehicles, the characteristics of the 6K engine (storable propellants, adaptability to a simple restart scheme, and controllable impulse) may well fit the use as a payload rocket. Lunar landings, accurate lunar or planetary orbits, accurate return to earth, and "stationary" 24-hr satellites all require an impulse-controlled final maneuver.

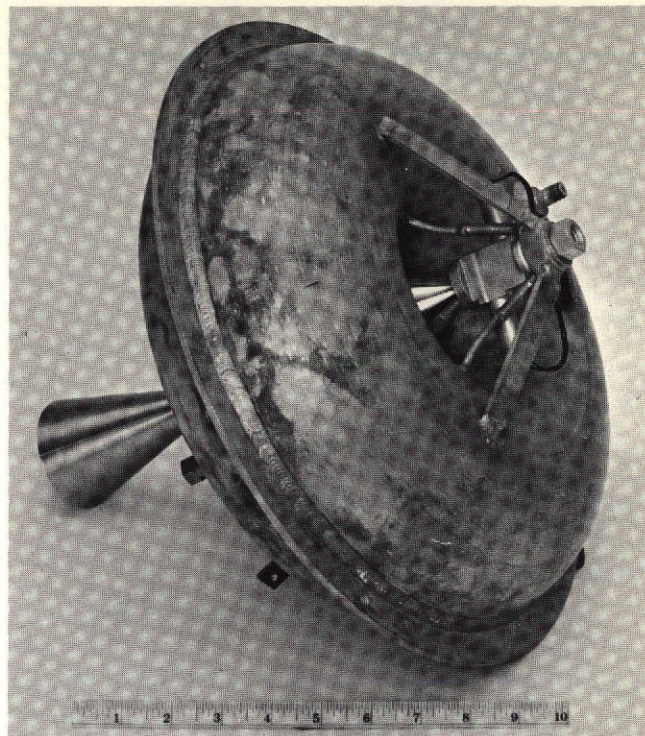

Fig. A-1. Small N_2H_4 Rocket Developed for Payload Use on *Juno II*

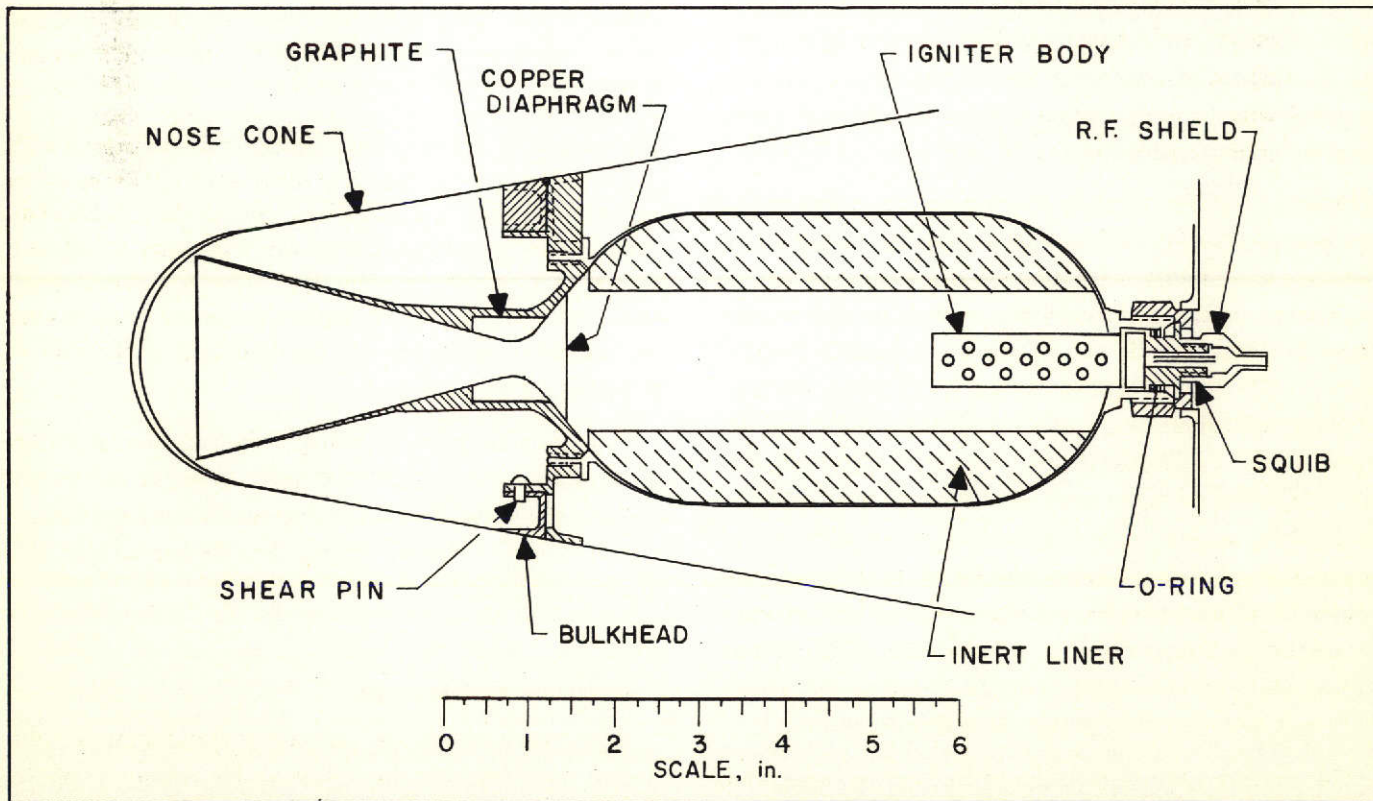

Fig. A-2. Small Solid Kick Rocket Employed on *Explorer VI*

The payload capacity of early *Vega* vehicles for interplanetary missions will be small enough to rule out the use of any maneuvering rocket whose weight is a major fraction of the total. Therefore, the first interplanetary payloads will carry, at most, a small trajectory-correcting rocket. The design requirements are severe. In addition to the obvious demands for maximum reliability, maximum impulse-to-weight ratio and impulse control or reproducibility, there is a demand for very accurate thrust alignment, or very low thrust, or both, in order that the rocket operation may not upset the payload attitude-control system. Also the jet, with its large expansion envelope, must not damage antennas, scientific equipment, or other sensitive payload components. On payloads whose primary stabilized axis is toward the sun, the rocket thrust should be along this same axis, and this is essentially the desired direction of a correcting impulse on typical interplanetary flights.

6. Payload Communications

The payload communication system for the *Vega* missions is being designed to provide two-way doppler velocity and range information, to telemeter scientific information to earth, and to receive and act upon commands sent from earth. In the first three *Vega* space missions, the communication system design will stress simplicity and reliability.

Figure A-3 shows a block diagram of the system, which consists of two completely independent transmitting systems. The first, which is considered to be primary, is a 250-mw, crystal-controlled transmitter similar to that flown in *Pioneers III* and *IV*. It is completely transistorized with the exception of the X3 (320 to 960 mc) varactor multiplier stage and the final power amplifier stage. Table A-6 relates its characteristics when employing a Goldstone-type receiving station. The 250-mw transmitter, which is a completely independent system possessing its own battery supply, is to be used for tracking purposes and for relaying payload performance data out to approximately one million miles. The antenna will be an omnidirectional, 0 db gain system and, therefore, will not depend on missile attitude control.

The second system, considered to be developmental, is a transponder consisting of a 890-mc receiver and a 25-watt, 960-mc transmitter. It will provide two-way

doppler velocity in addition to telemetry and command information. It will probably use a 7-db, cone-type antenna oriented in the proper direction to yield maximum gain in the direction of earth when the vehicle reaches its destination. This mechanization requires only one axis stabilization, namely, the sun-probe axis. The transponder (Fig. A-3) is basically a double superheterodyned, narrow-band, phase-lock-loop receiver and a transmitter whose frequency is integrally related to the received frequency. It includes a coherent AGC system, a command readout system, and a means for phase-modulating the transmitted carrier frequency with telemetry information. The transponder mechanization is designed to facilitate the addition of range readout and coding circuitry, angle tracking receivers, wide-band telemetry circuitry, increased receiver sensitivity, and increased transmitter power. It is anticipated that most of these additions will be included by the latter part of 1961. The transponder will be completely transistorized with the exception of the first IF amplifier input stage and the transmitter power amplifier stages. Table A-7 is an estimate of the weight and input power requirements for both the primary transmitter and the transponder. It is noted that since the transponder will be powered from solar cells, the weight estimate is based upon a conversion efficiency of 80% and a watt-lb ratio of 10.

The present transponder procurement schedule calls for the first two type-approval units to be delivered on or before November 1, 1959. These two units will be evaluated under the expected flight environments, which will include a 6-month lifetime test. The remaining eight units, six of which will be flight equipment or spares for the first three missions, will be delivered at the rate of two per month.

The communication system provides redundancy only out to approximately 1,000,000 miles, owing to the weight limitations on the first three flights. Redundant systems will be flown in future flights if sufficient weight and power are available.

7. Scientific Instruments

Photography. From an astronomy standpoint, a number of questions can be resolved by adequate photographic data, particularly if it becomes possible to take pictures in selected portions of the spectrum, e.g., visible

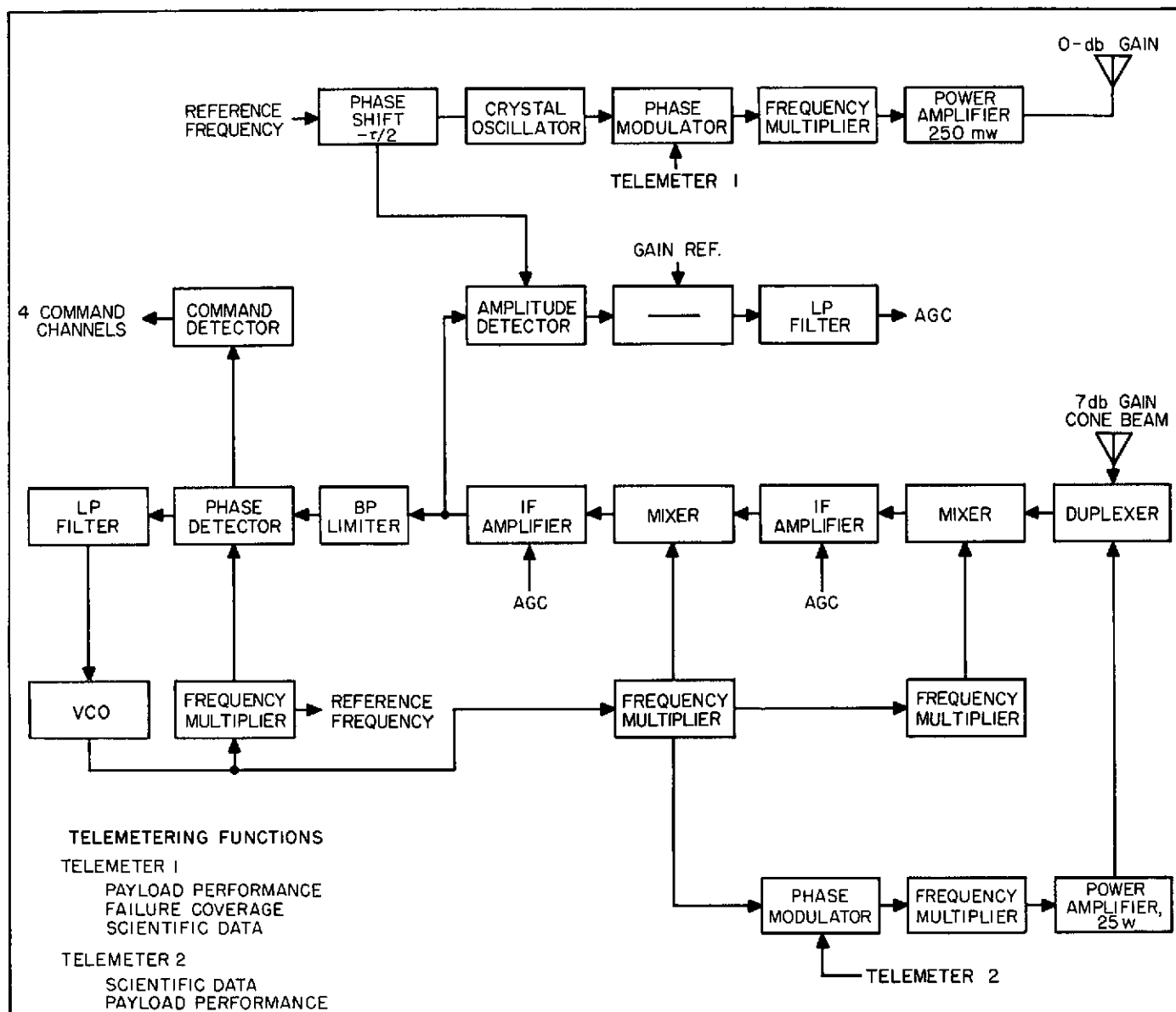

Fig. A-3. Payload Communication System

light, ultraviolet, and infrared. Aside from weight constraints, the most difficult problems in utilizing photography in deep-space exploration are the following:

1. Appreciable radiation fogging of film is expected as the vehicle passes through the Van Allen belt without proper shielding.
2. Because of the limited communication bandwidth available at planetary distances, it will be difficult to obtain high resolution pictures. It must be realized that, since even crude pictures contain in

the order of 10^6 bits of information which must be telemetered back with an available information rate sometimes as low as 10 bits per sec, it will take a little more than 20 hr. Naturally, the total number of bits in a picture is tied to the definition or raster required as well as the number of shades of gray, and a degradation of these requirements will make the problem somewhat easier.

3. The accuracy with which the attitude of a vehicle can be controlled enters into the problem of pointing the camera. If the film employed is somewhat

Table A-6. Vega Communication System Parameters

Item or Function	Vehicle-to-Earth Channel		Earth-To-Vehicle Channel
	Primary	Transponder	
1. Transmitter power, total dbm	24 (250 mw)	44 (25 w)	70 (10 kw)
2. Carrier power, dbm	18.6	36.2	69.0
3. Subcarrier power, dbm	22.6	43.2	63.0
4. Vehicle antenna gain, db	0.0	7.0	7.0
5. Carrier frequency, mc	960.100	960.050	890.046
6. Space loss, 1.61×10^6 km, db	216.2	—	—
7. Space loss, 80.5×10^6 km, db	—	250.2	249.5
8. Ground antenna gain, db	42.0	46.0	43.0
9. Received carrier signal level, dbm	-155.6	-161.0	-130.5
10. Received subcarrier signal level, dbm	-151.6	-154.0	-136.5
11. Receiving system effective noise temperature, °K	290	290	2900
12. Effective carrier noise bandwidth, cps	10	10	100
13. Effective subcarrier noise bandwidth, cps	10	5	10
14. Receiver carrier threshold, dbm ^a	-164	-164.0	-144
15. Receiver subcarrier threshold, dbm	-160 ^b	-157.0 ^c	-150 ^b
17. Carrier S/N ratio margin	8.4	3.0	13.5
18. Subcarrier S/N ratio margin	8.4	3.0	13.5
19. Duty cycle	continuous	continuous	—

^aSignal level for 0 db S/N ratio in carrier noise bandwidth.
^bSignal level for +4 db S/N ratio in subcarrier noise bandwidth for binary modulation.
^cSignal level for +10 db S/N ratio in subcarrier noise bandwidth for video modulation.

insensitive to radiation, it will be comparatively slow. It then becomes necessary to maintain this attitude with great precision over an appreciable time.

The present state of the art makes it possible to take pictures in space employing a raster of 200×200 lines per in., with a line resolution approximating 512 lines per in. The capability of the ground system is 1200×1200 lines per in. This resolution is quite far from that which can be expected in future years. It is anticipated that by continuing the development of the present system

it can be improved by a factor of 2 within a year. The present camera, developed for *Juno II*, is able to take 6 pictures, develop them, and telemeter them back at a rate of 1 picture per hr. The actual effect of radiation upon the performance of this system is yet to be determined, and the best procedure will probably be to expose some film to a known test pattern, transport it through the radiation belt, and then develop and telemeter it back.

Table A-7. Payload Communication System, Venus Trajectory Power and Weight Requirements

Component	Average Power, watt	Weight, lb
Primary transmitter (250 mw transmitter including power supply and antenna)	—	9.6
Total weight		9.6
Transponder ^a		
Receiver	5.5	15.0
Transmitter (25w)	137.0	2.2
Antenna system (7 db antenna and duplexer)	—	1.0
Total weight		18.2 ^a

^aTransponder weight does not include the solar cell power source.

In reference to the radiation belt problem, it should be possible to develop a film with an increased dynamic range to limit the influence of radiation. An alternative is to use an electronic film based on solid state phenomena; and research should be accelerated in this direction. This technique would simplify the procedure of developing film, which is not easy to accomplish with normal film on an automated basis out in space.

The development program includes the optics, shutter system, photographic device, and information storage system for bandwidth reduction. The shutter system is considered to include a target-seeking and experiment-pointing system. The complexity of such equipment will depend upon the attitude stabilization system for the payload.

The alternative to picture taking is television. A number of systems have been suggested, and some of them have been carried through partial development. One of these is a vidicon system which allows a picture to be taken and then stored electronically. The scanning rate of this picture is then regulated to conform to the avail-

able information rate. The resolving power and weight are still problems to be solved. At the present time, it is possible to obtain vidicon tubes with a sensitivity in the red region of the spectrum; development has been started to extend the sensitive region of these tubes to the far infrared. Development of high-resolution television has been started in industry. These systems have rasters of 2500×2500 lines per in, with spectral sensitivities that can be chosen in ranges from the ultraviolet to the far infrared.

The communications problem may be solved by proper coding of the telemetering. It is not necessary to telemeter the information on an absolute basis; it is possible to telemeter the changes in information from the previously sent information, and thereby to make it possible to send more information with a given bandwidth. Although a number of promising possibilities exist in the field of space photography and/or television, considerable development will be necessary before high-grade photography can be accomplished.

Magnetometers. Fluxgate or nuclear-precession magnetometers for space exploration are already available and more refined instruments with greater sensitivity and reliability will be ready for space flight by 1960. Among the types that appear most promising are the alkaline-vapor magnetic-resonance type, with a sensitivity of 10^6 gauss, and the nuclear precession-type recently improved by Russian scientists. Magnetometers of an extremely rugged construction are also under development at the present time.

Cosmic-ray instrumentation. A great number of experiments have been proposed in this particular field, which is of considerable interest to both cosmologists and astrophysicists. The instrumentation will require considerable development of individual components and transducers and further system development is needed.

The following items are slated for development (or, rather, redevelopment): (1) scintillation detectors with adequate sensitivity and sufficiently low noise, (2) sensitive photomultipliers rugged enough for the boost phase, (3) transistorized pulse-height analyzers with low power requirements, good reliability, and very good discrimination, and (4) ruggedized ionization chambers and counters.

System development includes such things as system engineering, packaging, and improving the data received

in comparison to the power and weight penalties implied by the instrumentation. A great number of these experiments have already been done on earth and must now be performed out in space. Development of the instrumentation for these experiments seems to be progressing reasonably, but a certain amount of re-engineering will be required, particularly in the field of automation and self-calibration, in order to render a maximum of data for the weight and power expended.

Meteor detectors. The experiments flown to date have shown that the concentration of micrometeorites is very nearly that which was originally anticipated. The gauges that have been employed in this field have been very primitive, giving data only on a *go/no-go* basis. For a complete study of interplanetary material, it is necessary to measure not only the abundance but also the total momentum of micrometeorites and also, if possible, their direction. This will necessitate development of transducers of a more complicated nature. Gauges based on the established leak rate of spheres of appreciable size would be able to indicate the number of puncturing impacts per unit area and time, and gauges based on secondary emission would give the total momentum. This will take considerable development, but still more engineering will be required in order to construct simulation devices to test these gauges before they are flown.

Mass spectrographs. A number of experiments using mass spectrographs have already been made in the field of upper-air research. These instruments have been carried by rockets and have obtained some data. However, considerable development work remains to be done if these instruments are to be able to analyze the composition of gases in the neighborhood or on the surface of a planet. Conventional magnetic-deflection instruments are competitive in almost every way with the best rf instruments being used in rockets. They do have the advantage of long testing in precise gas analysis so that they give more reliable results; research and development along these lines should be stimulated and supported, in addition to continued experimentation with rf instruments. With available instruments of both types, complications arise in measuring the neutral matter in space because of the very low pressures that exist there. The lowest pressure at which a magnetic-deflection instrument will give an acceptable current lies around 10^{-11} mm Hg, and the corresponding figure for an instrument of the rf type is 10^{-10} mm Hg. These limiting pressures are far too

~~CONFIDENTIAL~~

high; it becomes necessary to use a matter accumulator to collect material for a long period of time and then release it into a mass spectrometer for analysis. The use of titanium as a matter-collection device has been suggested, but considerable work must be done to understand the basic mechanism of this metal as well as to investigate the reversibility of the reaction. Although titanium might not be used, preliminary study shows it has possibilities.

For the electronics used in conjunction with these instruments, some development will be necessary, mainly because of the power and weight constraints associated with the payload as well as the problems of outgassing the payload to prevent gases from that source from interfering with the measurements.

When these instruments are used to analyze the composition of an unknown atmosphere, a further problem arises in regulating the pressure. The output figure is critically dependent on the maintenance of pressure at a known constant level. Considerable development will be needed before reliable figures can be derived from this type of instrumentation.

Ion probe. Instrumentation to measure the character and intensity of corpuscular radiation from the sun must be developed. A modified Langmuir probe or an improved model of the probe used in *Sputnik III* could be used. In all cases, this type of instrumentation will need electrometer tubes rugged enough to survive the boost phase and, at the same time, much less sensitive to emission variations derived from variation in the filament supply employed. In the same category are equipments to measure the direction, energy spectrum, polarity, and flux of these particles. These measurements are important not only from an astrophysical standpoint but also because of the expected contribution of these particles to the solar pressure on objects of reasonable area such as antennas or solar panels. This pressure will have to be taken into account in the guidance and attitude control of space vehicles.

Spectrophotometers. These instruments have been invaluable tools of astronomers on earth and, with the advent of deep-space exploration, more elaborate requirements for this type of instrumentation will result. Far above our atmosphere, with an undistorted view of the objects in question, these instruments will be called upon to work in the extreme ends of the spectral range.

A broad development program will be necessary to adapt these instruments to space flight. Consider the problem of assigning a spectrophotometer to work in the infrared portion of the spectrum. Prism materials that will be able to stand the vibration and acceleration of the boost phase do not now exist. A broad investigation of the materials problem will be required, as well as development of techniques of automation and self-alignment for these instruments. Employment of such instruments for space exploration will also, in most cases, put severe requirements on the attitude control of the payload, since for the normal case the cone angle to the target will be very small. If this question can be solved and the angle maintained for reasonably long periods of time, requirements on the information rate needed to telemeter the results should not be too severe. Development of sensors for aiming and tracking these instruments will be necessary, since the information from the spectrophotometer will, by its very nature, be difficult to use as the criterion for correct alignment to the target.

Timers. In addition to the timing requirements in the boost phase, the payload itself will also have certain timing requirements. The timing functions required of these timers include cycling the transmitter, switching telemeter channels when the number of experiments in the payload exceeds the number of channels available, and acting as general logic circuitry in the payload. The timers employed must, by the nature of the mission, have a long life. Associated with logic circuitry, they should operate in the payload with their own independent power supply.

The projected timer may have to be a solid state type because of the power constraint; it should be able to be programmed easily, both as a one-shot timer and as a recurrent one. The over-all timing cycle will depend on the mission; the timer should be able to function for at least 6 months. The over-all power drain should be no more than 200 mw. The accuracy should run better than 1%, and the incremental accuracy should be better than 1/2% in the total environment experienced.

8. Payload Reliability

Throughout the payload development program, reliability will be attained by means of a verification safety margin technique similar in concept to that employed for the vehicle equipment. The major difference will concern

~~CONFIDENTIAL~~

the environmental conditions encountered by the payload during space flight, which will be considered in addition to those resulting from the handling and launching of the payload. Of particular concern are the time periods during which the equipment will be subjected to the space environments; periods as long as 6 months are to be expected; therefore, extensive life-testing must be performed for design verifications.

In addition to the handling and ambient conditions and the launching conditions that will be encountered

by all *Vega* flight equipment, the payload must survive space conditions throughout its flight, which may last as long as 6 months. Conditions of particular interest are cosmic rays (10 r/hr in certain regions in space), micrometeorites, ultra-low vacuums (10^{-17} mm of Hg), solar radiation and associated heat balance and temperature conditions, and zero gravity. Special consideration will be required to verify the adequacy of payload designs with regard to these long times and unusual conditions.

110116