

General Disclaimer

One or more of the Following Statements may affect this Document

- This document has been reproduced from the best copy furnished by the organizational source. It is being released in the interest of making available as much information as possible.
- This document may contain data, which exceeds the sheet parameters. It was furnished in this condition by the organizational source and is the best copy available.
- This document may contain tone-on-tone or color graphs, charts and/or pictures, which have been reproduced in black and white.
- This document is paginated as submitted by the original source.
- Portions of this document are not fully legible due to the historical nature of some of the material. However, it is the best reproduction available from the original submission.

The Promise of Multicyclic Control

John L. McCloud III

(NASA-TM-78621) THE PROMISE OF MULTICYCLIC
CONTROL (NASA) 36 p HC A03/MF A01 CSCL 02A

N79-31137

Unclas
35751
G3/01

August 1979

NASA
National Aeronautics and
Space Administration



The Promise of Multicyclic Control

John L. McCloud III, Ames Research Center, Moffett Field, California



National Aeronautics and
Space Administration

Ames Research Center
Moffett Field, California 94035

THE PROMISE OF MULTICYCLIC CONTROL

John L. McCloud III

Ames Research Center, NASA, Moffett Field, Calif. 94035

Abstract — The rough ride a helicopter endures is known to be self-generated. This roughness results in fatiguing blade loads and vibration which can be eliminated or greatly reduced by multicyclic control. Rotor performance may also be improved. Several types of rotors which have employed multicyclic control are reviewed and compared. Their differences are highlighted and their potential advantages and disadvantages are discussed. The flow field these rotors must operate in is discussed, and it is shown that simultaneous elimination of vibration and oscillatory blade loads is not an inherent solution to the roughness problem. The use of rotor blades as energy absorbers is proposed. Input-output relations are considered and a gain control for ROMULAN, a multicyclic controlling computer program, is introduced. Implications of the introduction of multicyclic systems into helicopters are also discussed.

INTRODUCTION

When a helicopter enters into forward flight it loses the polar symmetry of the airflow through the rotor disk that it had in hover. As the speed increases, the blades encounter differencing velocities on the left- and right-hand sides of the aircraft. These velocity differences are compounded by the velocities of a helically shed trailing vortex system. They combine to produce a very rough ride for the rotor blades and the aircraft it carries, even in smooth air. Vibration at high forward speed

is accentuated by stall and compressibility effects, and even for compound helicopters with auxiliary propulsion, wake-induced vibration remains a problem.

Basically, vibrating loads are periodic, and in steady flight, air-loading and response are almost perfectly periodic. Response can occur at frequencies which are not multiples of the rotational speed due to structural resonances in the blades or airframe. These responses will be small, however, for a well-designed aircraft, since placement of resonance frequencies away from n -per-rev is a basic rule of helicopter design to keep loads and vibration low.

Gust-response vibration, another problem, is non-periodic, and generally has low frequencies.

Inasmuch as the blades encounter these loads periodically, it is natural to consider the application of multicyclic control to the blades to avoid, or at least relieve, those loads. Specifically, multicyclic control[†] is that motion applied to a rotor blade's control device to avoid or alleviate the periodic loads encountered by the blade when in non-axial flight. Generally, once-per-rev (1P) cyclic is reserved for control of the rotor's lift, side, and propulsion forces, and n -per-rev (nP) is used for multicyclic control.

[†]The term "higher harmonic control" is often used synonymously with "multicyclic control," however this writer prefers the latter, leaving higher harmonic control to those seeking to control acoustic frequencies which are truly higher harmonics.

The first victims of the helicopter's self-generated rough ride are the rotor blades. If the blades are constructed of metal structural elements (a spar with skin and rib sections) which are designed as a compromise between strength and weight, they are subject to large oscillating bending stresses due to the loads caused by the inflow into the rotor. These oscillatory loads can result in fatigue of the rotor blades and limited life. If the blades are made with fibrous material, such as wood or the modern plastic fibers, they can generally withstand the loads. They will, however, transmit oscillatory loads as oscillatory forces and moments to the helicopter itself by the hub and/or the control links. Multicyclic control can reduce these oscillatory forces.

At a given level of lift and propulsive forces, the power required to drive the rotor in forward flight depends on the loading distribution. Since the inflow determines the distribution, it affects the power, and by altering the inflow distribution, multicyclic control can reduce the power.

From the above it is apparent that the promise of multicyclic control is to avoid or alleviate the problems generated by the helicopter's oscillatory loads. While the action of the system is predicated on the rotor's self-generated roughness, the frequencies involved are such as to permit control motions for gust alleviation as well, which may allow incorporation of an active gust-control system. For the present, however, only the self-generated, truly periodic load alleviation is considered.

With the foregoing description of the potential of multicyclic control, the remainder of the article will discuss this potential in terms

of what has been done, the input-output relations, the selection of control variables, and what some of the control system implications are.

What has been done. Figure 1 shows several types of rotors which utilized multicyclic control. The first rotor [fig. 1(a)] is a conventional type controlled by cyclic feathering of the blades. Included in this category are teetering, non-articulated (no flapping or lead-lag hinges), and fully articulated rotors. The teetering type used only first (1P) and second harmonic (2P) control motions, and the test was considered unsuccessful [1]. The non-articulated rotor test was part of a larger hingeless-rotor investigation of a four-bladed 2.3 m-diameter rotor, where the swashplate was oscillated at 4P [2]. The instrumentation was limited, but it did provide signals which were interpreted as a measure of rotor-pitching and rolling-moment oscillations. (The signal interpreted was a flap-bending moment trace for the 0.073 R radial station.) Those data indicated that these moments could be reduced to zero without self-defeating blade-bending stress changes. Investigations of full-blade feathering of articulated rotors are being carried out at Boeing-Vertol [3], Hughes Helicopters [4], and NASA Langley [5]. These investigations have utilized model rotors and have been aimed at reducing vibratory loads without causing deleterious effects on rotor-bending loads or performance. These investigations have in common the use of swashplate oscillation of four-bladed rotors so that the blade-feathering motions were at 3P, 4P, and 5P. These investigations, employing model rotors, have also been successful in reducing vibratory forces, again without causing self-defeating stress increases in the blades.

The second rotor [Fig. 1(b)] is the fully articulated Controllable Twist Rotor (CTR) built by Kaman Aerospace Corp. It has been tested full scale with multicyclic control applied to the servo-flap at 0P, 1P, 2P, 3P, and 4P frequencies. The 0P and 1P cyclics were introduced by a swashplate, while the higher harmonics were applied by actuators in the rotating system. Normal collective and longitudinal and lateral cyclic control are applied to the blade root. Blade-bending loads, flapwise, chordwise, and torsional, were modulated by multicyclic control as were control loads, vibratory loads, and the total rotor performance. All loads could be reduced with reasonable cross coupling and without significant performance changes. The analytical phases of this investigation have been reported in Refs. 6 and 7, and the experimental phase in Refs. 8 and 9.

The third rotor [Fig. 1(c)] is the Giravions Dorand Jet-Flap Rotor which is driven and controlled by the jet-flap. It was tested with multicyclic (2P, 3P, and 4P) applied by a cam, and with a conventional swashplate system for the steady and cyclic control, 0P and 1P, respectively. This 12 m-diameter, two-bladed teetering rotor with offset coning hinges, demonstrated reduced blade-bending moments and vertical hub shears (the latter as measured in the nonrotating system). Interpretation of the data indicates a simultaneous 50% reduction of these loads could be realized with multicyclic control. These investigations are documented in Refs. 10, 11, and 12.

The nonpropulsive jet-flap rotor in Fig. 1(d) was investigated analytically, as reported in Refs. 13 and 14. The rotor simulated the characteristics of Bell UH-1A blades, but employed half-span jet-flaps

for multicyclic control. Both two- and four-bladed versions with offset flapping hinges were considered. In this study, the objective was to eliminate transmitted root shears while monitoring blade-bending moments and total power. Jet-flap oscillations were considered at 2P through 11P, with 0P and 1P deflections utilized for trim of the rotor. Elimination of transmitted root shears was realized for both rotors. Interestingly, the elimination of the transmitted oscillatory shears was realized by the twisting of the blades caused by the local pitching moments induced by the jet-flap. A rotor with blades much stiffer in torsion also realized zero transmitted shears, but with increased jet deflections as would be expected. Power changes and changes in blade-bending loads were very reasonable. This theoretical investigation has not been substantiated by experiments.

The Circulation Control Rotor (CCR) and the X-wing rotor are also natural candidates for multicyclic control [Figs. 1(e) and 1(f)]. These rotors, which have no articulation, utilize airfoils whose circulation is controlled by Coanda jets. These jets in turn control the forces and moments generated by the blades and the rotor itself. Collective or steady blowing plus 1P oscillating blowing provide rotor control. Control modulation is completely in the non-rotating system with no moving parts in the rotating system. This enables the introduction of higher harmonic control not only in the fixed system but with static controls. This is equivalent to warping the swashplate. Although some theoretical studies have been made of these systems, they have not yet been published. Both systems are undergoing full-scale testing (hovering, and at forward speeds in the Ames 40- by 80-Foot Wind Tunnel), and both have the higher harmonic-control capability. For example, some investigations with 2P

control applied to prove performance have been made with a model rotor [15]. In both instances the rotors are quite stiff, so that the reduction of transmitted shears will probably be the multicyclic goal rather than blade-loads reduction. The X-wing rotor is designed to be stoppable in flight. Multicyclic control could, therefore, be utilized during rotor start/stop transitions. When the rotor is stopped the controls could still be active, but the terms cyclic multicyclic, and harmonic have no intrinsic meaning to the then fixed-wing aircraft. Some performance benefits may be looked for with higher harmonics applied to the CCR, but the power required for the high-speed flight of the X-wing would probably make such gains of academic interest only.

The advanced controllable-twist rotors [Fig. 1(g)] are conceptual. In both instances, the tip region of the blade is swept aft, so that a) the aileron-type servo-flaps have sufficient blade-twisting power, but with lower drag than the normal blade-mounted servo-flap, and b) beneficial Mach number drag effects due to sweep are enjoyed. The second CTR would have both inboard and outboard flaps as well as a completely bearingless/hingeless hub. Blade and hub would be integral and made of composite fibers so as to have infinite fatigue life.

The successes of the propulsive jet-flap, the CTR, and full-blade feathering rotors with multicyclic control indicate all could provide aircraft with zero vibratory forces from the rotors. Full-blade feathering would appear to be the simplest solution if adequate actuators can be provided and the safety and reliability of the basic control system are not jeopardized. With swashplate oscillation, six control functions are available; sine and cosine controls for oscillatory collective,

longitudinal, and lateral cyclic controls. The CTR is the simplest since it employs technology and techniques well within the state of the art. Its dual control nature and the low mechanical loads afforded by the servo nature of the flap satisfies basic safety and reliability consideration. Nine control motions are available with this system, including collective, and four harmonics of sine-cosine control.

The present CTR suffers performance drawbacks due to unnecessary inboard blade-spar drag and drag associated with the trailing servo-flap. It did, however, exhibit a significant increase in lift coefficient capability at forward speed. The propulsive jet-flap rotor has less technology behind it, and although the rotor has superior lift coefficient capabilities, the high fuel consumption of jet propulsion augers against it in the present petrochemical climate. It is possible that heavy lift crane and/or stoppable rotor configurations might prove sufficiently desirable to pursue this concept. The CCR and X-wing rotors are low on background technology. However, the fact that multicyclic control can be introduced with essentially static, non-cyclic motion, implies these rotors could have the simplest multicyclic controllers. Dependent upon the acceptance of circulation-controlled rotors in general, such rotors would doubtlessly employ multicyclic control. The advanced CTR's are obvious projections to remedy the present CTR's drawbacks.

CHARACTER OF ROTOR FLOW FIELDS

Before discussing the selection of control variables, it is helpful to examine the flow field in which these systems must operate. Figure 2 shows the inflow and inplane velocities for a lifting, propelling rotor

at 0.30 advance ratio.[†] Note particularly the forward portion of disk for the inflow velocity. It is characterized by radially adjacent upwash and downwash regions due to the rotor crossing its own vortex system. The inplane velocities [Fig. 2(b)] and the inflow velocities in the aft portion of the rotor disk [Fig. 2(a)] are predominately azimuthal variations. In the latter case, it would seem that whole blade motion, as in multicyclic feathering or multicyclic twisting, would be quite effective, whereas for the forward portion of disk, control which can alter the distribution of load changes (by segmentation, for example) would seem to be indicated. This type of inflow will also occur at higher advance ratios. At lower velocities, however, the inflow will contain more vortex trail crossings. (The author knows of no multicyclic investigations covering the lower velocity ratios.) Perhaps some sort of control segmentation would be required.

WHAT TO CONTROL

As stated in the introduction, multicyclic control could reduce blade-bending moments (flatwise, chordwise, and torsion), hub and control loads transmitted to the fuselage, and rotor power. Reducing the blade's oscillatory bending moments to zero obviously requires the radial distribution and magnitude of the airloads to remain constant with azimuth. The retreating blade problem makes such a uniform load impossible, however

[†]This inflow has been calculated for a vortex-system with fixed strength and geometry. Although it is not a truly accurate model of the flow, it is satisfactory for the discussion herein.

reductions in oscillatory blade loads are possible. The part of those oscillating airloads which is transmitted to the fuselage as shears, is independent of the radial distribution and depends only on the summation of the radial distribution of the airloads. For example, a unit load which moved radially in and out of the blade as it circled the mast would not develop oscillatory shears, but would develop oscillatory blade-bending loads. The upwash-downwash combinations, characteristic of the forward part of the disk inflow [see Fig. 2(a)], result in "couples" (upward and downward loads) which travel in and out of the blade. They have no shear reactions to transmit, but definitely cause oscillatory blade-bending loads. While it is not possible to derive a simple (and credible) model to prove that complete reduction of transmitted shears is possible by use of multicyclic control, theoretical analyses and interpolation of experimental data indicate that it can be done. The above discussion is included here to help explain why bending moments and transmitted shears are not necessarily simultaneously minimized at the same multicyclic control settings. Again, however, both theoretical analyses and interpolation of experimental data indicate simultaneous reductions can take place [4, 7, 12].

It is also interesting to examine how a shear is reduced to zero. In Fig. 3(a), five components of the fifth harmonic of blade-root shear and their resultant are shown. Figure 3(b) shows these same five components with fifth harmonic jet-flap control applied to eliminate the 5P root shears. (Figure 3 is based on Fig. 33 of Ref. 13.) Note that all the component loads (except the second flap bending) have increased on the order of 6 times to facilitate the elimination of the resultant fifth

harmonic vertical shear. For this harmonic the root shear depends upon several almost equal-magnitude inertia loads as well as the aerodynamic loads. This dependence indicates that a fairly sophisticated model will be needed for both theoretical and experimental investigations. Although blade bending may be tolerable from a strength and fatigue point of view, its contribution to inertia loads must be considered in all investigations.

Another interesting concept in vibration control is illustrated in Fig. 4. It shows what might be the oscillating loads experienced by a blade as a function of forward flight speed. If the infinite life load is made to match the forward speed limit, the shaded area indicates permissible increases in oscillatory blade loads without incurring fatigue damage. Thus a multicyclic control system which absorbs some of the energy of oscillating loads in the blades may provide the best vibration reductions. This figure also illustrates why the primary objectives of multicyclic control will probably be vibration reduction rather than oscillatory blade-load relief.

The foregoing may be summarized by saying that, while blade bending and forces transmitted to the fuselage are coupled, they are not coupled so as to produce simultaneous minimums. Because of different response frequencies in a blade, the couplings are frequency sensitive. Further, when several harmonics of multicyclic control are applied, the probability of simultaneous reductions is greatest. While it is semantically correct to call 2P systems higher harmonics or multicyclic control, systems which have more control variables (e.g., 3P and 4P with phase controls) stand a better chance of controlling more rotor outputs. Designers must decide

what rotor outputs should be controlled, but research will decide what outputs can be controlled.

INPUT-OUTPUT RELATIONS

The method preferred by this writer to relate input and output of multicyclic systems is a weighted multivariable linear regression analysis implemented by the computer program ROMULAN. This program was developed by Dr. Jean-Noel Aubrun of Giravions Dorand, France [10]. Specifically, the program assumes linear relationships between the output's harmonic components and the input's harmonic components. Experience has shown [5, 9, 10, 12] that this is a reasonable assumption. This procedure requires harmonic analysis of input and output signals. However, when the input system itself is reasonably linear (between cockpit control and the ultimate controller, such as the blade-mounted servo-flap of the MCTR), cockpit control settings could be used for the input parameter. If vibration from a non-rotating system is used for output, it is possible that the rotor's filtering characteristic might simplify the harmonic analysis. Response phase information is still required, however. Additional filtering might be employed if phase information is also obtained. Relating peak-to-peak quantities to control settings as done in Refs. 6 and 8 simplifies the procedure in that the input can be expressed by the cockpit control settings, and harmonic analyses of the input and output are not needed. However, since peak-to-peak values cannot be related by linear transforms to either harmonics of the input control, or input control settings, it follows that a nonlinear regression analysis would be required. Moreover, a larger data base is required to adequately

evaluate the nonlinear relationship since many more parameter coefficients must be determined. The sensitivity to noise in the data is also increased if the filtering characteristic of the harmonic analysis is not used. If the multicyclic control is to be used in a feedback control system, sufficient computer power will be required in both instances (i.e., for linear harmonic component analysis or nonlinear peak-to-peak analysis), so that final decisions as to input-output relations will rest on system performance efficiency.

ROMULAN has been discussed in Refs. 7, 9, 10, and 12. It calculates a transfer function matrix T from measured (or theoretically calculated) rotor output parameters and rotor input parameters by least-square regression techniques. With selected weighting prescribed, the code then calculates ideal inputs which will minimize the sum of the weighted squares of selected output parameters. It then calculates "predicted" harmonic components, time histories, etc., and an input required to achieve them.

Mathematically, the output parameters (F_n) are related to input parameters (f_n) by:

$$(F_n) = [T](f_n) \quad (1)$$

which may also be written

$$(F_n) = [T_p](f_p) + [T_m](f_m) \quad (2)$$

where the first product represents the outputs without multicyclic, and the second product represents the effects of multicyclic. For user-specified (F_n) and weighting, ROMULAN calculates (f_{m_1}) for the minimum $\sum_n (wF_n)^2$. The solution for (f_{m_1}) , the ideal control schedule, is

$$(f_{m_1}) = -[T_m^T T_m W]^{-1} [T_m^T T_p W](f_p) \quad (3)$$

where

$$[Tm_w] = [w][Tm]$$

and

$$[Tp_w] = [w][Tp]$$

and $[w]$ is the diagonal weighting matrix.

Note that ROMULAN, in determining ideal control schedules, has effectively minimized a nonlinear relationship between the rms output parameters and multicyclic input components. If the input vector (fm) contains 12 elements, the equivalent nonlinear rms relationship has 78 elements.

A limitation of the existing ROMULAN code is that while it determines ideal control schedules (fm_i) and the resulting output components, nothing is indicated as to what outputs would result while the controls were going from no multicyclic to the ideal schedule. Further, in the event the ideal schedule calls for input components beyond the capability of the system, the question arises as to what should be done. These problems can be handled in the following manner:

Consider the components of the ideal control schedule to be modulated by a gain control so that $(fm) = G(fm_i)$; then Eq. (2) becomes:

$$(Fn) = [Tp](fp) + G[Tm](fm_i) \quad (4)$$

Thus each pair of output harmonic components are given by

$$\begin{pmatrix} F_{\cos} \\ F_{\sin} \end{pmatrix}_n = \begin{pmatrix} P_{\cos} + G \cdot m_{\cos} \\ P_{\sin} + G \cdot m_{\sin} \end{pmatrix}_n$$

If plotted as in the sketch below, the variation of the harmonic component output F_n can be tracked as the gain G is varied from 0 (no multicyclic) to 1.0 (ideal multicyclic).

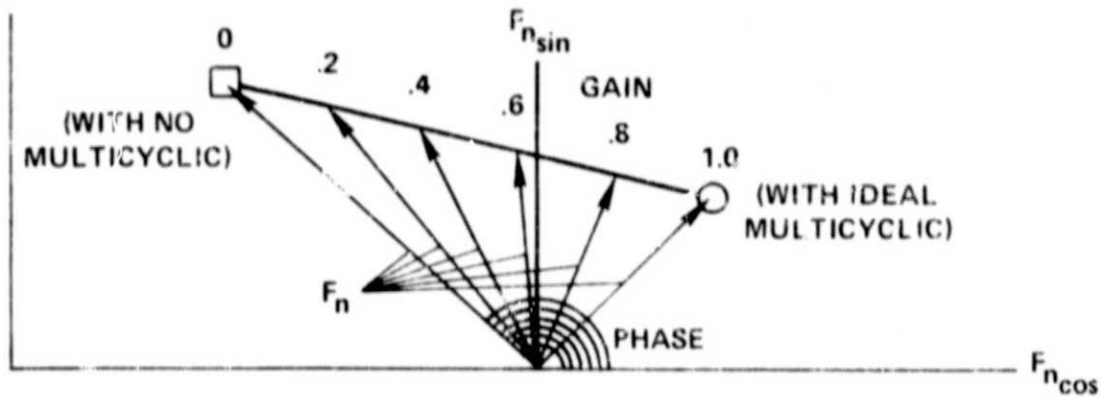

Figure 5 is a collection of such plots for the ideal schedule for 0.22 advance ratio of Ref. 9. This corresponds also for lift and propulsive force coefficients of 0.105 and 0.012 and equal weighting of the actuator and flapwise bending signals. The "ideal" condition corresponds to the minimization of the sum of the squares of the output components. As the gain G is increased from zero, all components are reduced (closer to the origin of the plots). At about 0.5 gain, the actuators are nearing their minimum loads. As the gain is further increased, the actuator loads increase while the flapwise bending components continue to decrease. Corresponding time histories are shown in Fig. 6 for the flatwise bending. The changes in amplitude and phase of the root actuator 4-per-rev loads are shown in Fig. 7. Had greater weight been given to the bending loads in the optimization process, the "ideal" components for bending would be nearer the origins, and the "ideals" for the actuators would be farther away. The reverse would be true for increased weighting on the actuator signals.

In the event some component of the ideal control cannot be physically implemented, a limit gain can be calculated and the corresponding component

outputs determined. Weighting changes will also change the ideal schedules which may also affect the limit gain.

CONTROL SYSTEM IMPLICATIONS

The first system implication is safety. Multicyclic control systems must, of course, not jeopardize flight safety. They must also, obviously, be reliable and free from their own maintenance problems to insure that, by reducing vibration, they make the total aircraft more reliable and maintenance free. These are not insurmountable requirements, however. It would be foolish to apply harmonic signals to an aircraft's control actuators and then have the actuators fail so that the pilot had no control. Worse still would be fatigue failure in the mechanical system. Parallel systems which can fail without affecting the primary control are possible. For example, the CTR system separates the main (blade-root) control completely from the servo-flap control. Further, the CTR's dual control increases the flight safety of an aircraft so equipped. Actuators which oscillate the pivots of rocker arms, or bell cranks, can be separate from the main actuators. The complete train of control rods must, however, be reevaluated to assure that the additional motions due to multicyclic control have not jeopardized the primary control loads and stresses. Systems which are in the rotating frame have problems of getting power and signals into the rotating frame. These systems have the additional problem of sending reaction forces to the fixed frame of reference. Servo-driven systems have the advantage of requiring the least power and, because of size, the simplicity of parallel applications. Actuator requirements will, of course, depend on the specific rotor

involved and the harmonics of control motion required. Except for small diameter, high tip-speed rotors, the actuators must be workable at frequencies from 12 to 20 Hz for 4-per-rev coverage, and 15 to 25 Hz for 5-per-rev, as shown in Fig. 8. In spite of expected problems, researchers have been able to obtain these responses with good-quality hydro-electric actuators. Kaman supplied carefully rebuilt units which were used with the 17-m- (56-ft-) diameter Controllable Twist Rotor at frequencies up to 14 Hz. Other test models have not shown any difficulties at much higher frequencies. (A tenth-scale model would require 10 times the frequencies shown in Fig. 8.)

Mechanical actuators are also feasible, particularly if they are used in the non-rotating system. There a single frequency n -per-rev provides three frequencies, $n-1$, n , and $n + 1$, in the rotating system as shown in Ref. 16. In general, n would be equal to the number of blades. For ganged systems, $2n$ -per-rev could add $2n - 1$, $2n$, and $2n + 1$ frequencies to the rotating system.

As indicated earlier the CCR and X-wing systems are very attractive. They can develop multicyclic control naturally in the fixed system with non-cycling parts. Similar systems could be utilized with both propulsive and nonpropulsive jet-flap rotors.

Also to be considered is the direct effect of multicyclic system failure. The aircraft so equipped must be capable of flight with the multicyclic system turned off, sufficient to safely abort the mission. If multicyclic control is to be used to permit order-of-magnitude speed increases significantly beyond endurance limits, it should be failure-proof.

The second system implication stems from the number of things to be controlled. Unless there are advantageous couplings, each item to be controlled must have a controller. Since the rotor's vibration is self-generated, a preprogrammed control may be adequate. Inasmuch as aerodynamic imbalance between blades can cause vibration, and balance may differ from ship to ship or from week to week, a special "balancing run" with an on-board computer might be made to develop preprogrammed control for each aircraft. With special transducers installed, data for the transfer matrix would be gathered for the complete flight envelope, and optimal control schedules could be determined. These schedules would then be utilized until changes in the aircraft response dictated a new "balancing run." In any event, flight tests and/or full-scale wind tunnel tests will have to be made of any multicyclic system.

FEEDBACK CONTROL SYSTEM

An adaptive type of feedback control for a multicyclic system was first proposed by Giravions Dorand [10]. The basic scheme was as shown in Fig. 9. Outputs from the rotor such as root shears, blade-bending loads, actuator loads, etc., are sent to a processing unit. These signals, together with signals reflecting the input multicyclic control and flight conditions, would be used to establish a control function. This control function, in turn, would be used to define multicyclic control schedules designed to optimize certain rotor output parameters. The optimal or ideal control schedule is then fed back to the rotor's control system. Reference 17 presents some additional studies of a feedback control system with multicyclic control and the controllable twist rotor. In that

instance, an optimization function is defined combining several output parameters such as rotor power, blade-bending moments, transmission vibration and rotor pitch-link loads. The optimization function is designed to insure that each parameter is kept below a preset level while the function itself is minimized. The individual parameters (either average or peak-to-peak values) are determined from nonlinear relationships which have been established by regression analyses of rotor input and output information. The optimal control schedule would similarly be fed back to the multicyclic control system. As noted before, the nonlinear regression analyses require a large data base.

Reference 4 discusses a similar feedback system, and other researchers are known to be working in the field.

SUMMARY

Multicyclic control has been found effective in reducing blade stresses and rotor-produced vibrations. It has not always been completely successful — since some stresses increased while others were reduced. In most cases, multicyclic control was successful in reducing blade stress and vibrations simultaneously. Some systems are tied to special rotor systems, such as the jet-flap and controllable twist rotors. Others, such as full blade feathering, can be tied to almost any rotor.

Examination of the flow field a rotor flies in, indicates whole-blade motion may be most effective over the aft portion of disk, whereas segmentation may be more effective over the forward aft portion. It has also been postulated that increases in the oscillatory blade loads which accompany fuselage vibrations may be advantageous.

Input-output relations have also been discussed, and for adaptive feedback control systems or laboratory analytical investigations, no clear-cut advantages of linear harmonic component relations or nonlinear peak-to-peak relations were found. The introduction of a multicyclic gain control was presented to aid in visualizing the transition from no-multicyclic to ideal-multicyclic control. It may also be used to assess the problem posed by ideal control deflections exceeding those physically possible by a particular control system.

Implications of hardware problems due to the addition of multicyclic controls are discussed. No insurmountable disadvantages are found, however, to delay the use of multicyclic or high-harmonic control to eliminate fuselage vibration and possibly reduce mode bending and improve performance.

REFERENCES

1. J. M. Drees and R. K. Wernicke, An experimental investigation of a second harmonic feathering device on the UH-1A helicopter. Bell Helicopter Company, Fort Worth, Texas; TRECOM TR-62-109, Fort Eustis, Virginia, June 1963.
2. G. J. Sissingh and Robert E. Donham, Hingeless rotor theory and experiment on vibration reduction of periodic variation of conventional controls. Proceedings of the AHS/NASA Ames Specialists' Meeting on Rotorcraft Dynamics, Feb. 1974 (NASA SP-352, Feb. 1974).

3. F. J. McHugh and J. Shaw, Benefits of higher harmonic blade pitch: vibration reduction, blade load reduction, and performance improvement. Proceedings of the American Helicopter Society Mideast Region Symposium on Rotor Technology, Aug. 1976.
4. E. R. Word, R. W. Powers, and C. E. Hammond, On methods for application of harmonic control. Paper No. 22, Presented at Fourth European Rotorcraft and Powered-Lift Aircraft Forum, Stresa, Italy, Sept. 1978.
5. C. E. Hammond, Helicopter vibration reduction via higher harmonic control. Structures Laboratory, U.S. Army Research and Technology Laboratories, Proceedings of the Rotorcraft Vibration Workshop, NASA Ames Research Center, Feb. 22-23, 1978.
6. A. Z. Lemnios and F. K. Dunn, Theoretical study of multicyclic control of a controllable twist rotor. U.S. Army Air Mobility Research and Development Laboratory, Moffett Field, California, NASA CR-151959.
7. J. L. McCloud, III, An analytical study of a multicyclic controllable twist rotor. Preprint No. 932, 31st Annual National Forum of the American Helicopter Society, Washington, D.C., May 1975.
8. F. S. Wei and A. L. Weisbireh, Multicyclic controllable twist rotor data analysis. Kaman Aerospace Corp. NASA CR-152251.
9. J. L. McCloud, III and A. L. Weisbireh, Wind-tunnel test results of a full-scale multicyclic controllable twist rotor. Preprint No. 78-60, 34th National Forum of the American Society, Washington, D.C., May 1978.
10. M. Kretz, J. N. Aubrun, and M. Larche, March 1971 wind-tunnel tests of the Dorand DH 2011 jet-flap rotor. NASA CRs 114693 and 114694.

11. J. L. McCloud III, Studies of a large-scale jet-flap rotor in the 40- by 80-foot wind tunnel. Presented at Mideast Region Symposium A.H.S. Status of Testing and Modeling Techniques for V/STOL Aircraft, Philadelphia, PA, Oct. 1972.
12. J. L. McCloud III and Marcel Kretz, Multicyclic jet-flap control for alleviation of helicopter blade stresses and fuselage vibration. Proceedings of the AHS/NASA-Ames Specialists' Meeting on Rotorcraft Dynamics. NASA SP352, Feb. 1974.
13. R. A. Piziali and A. R. Trenka, A theoretical study of the application of jet flap circulation control for reduction of rotor vibratory forces. For USAMRDL and NASA, Ames Research Center, NASA CR-137515, May 1974.
14. A. R. Trenka, A theoretical study of the application of jet flap circulation control for reduction of rotor vibratory forces — an addendum. For USAMRDL and NASA, Ames Research Center, NASA CR 137779, Oct. 1975.
15. F. K. Dunn, An analytical investigation of a multicycle circulation controlled rotor. Report No. R-1403, Kaman Aerospace Corp., Bloomfield, Connecticut, Jan. 1978.
16. J. C. Biggers and J. L. McCloud III, A note on multicyclic control by swashplate oscillation. Ames Research Center, NASA TM 78475, 1978.
17. A. Weisbireh, R. Perley and H. Howes, Design study of feedback control system for the multicyclic flap system rotor. Report No. R-1494, Kaman Aerospace Corp., Bloomfield, Connecticut, NASA CR-151960, Jan. 1977.

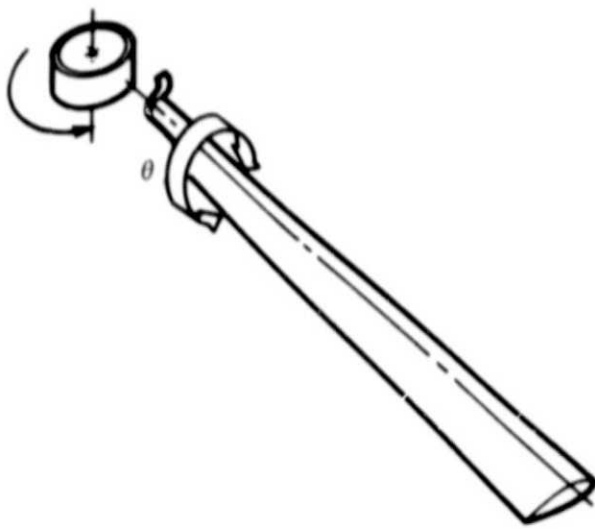

(a) FULL BLADE FEATHERING

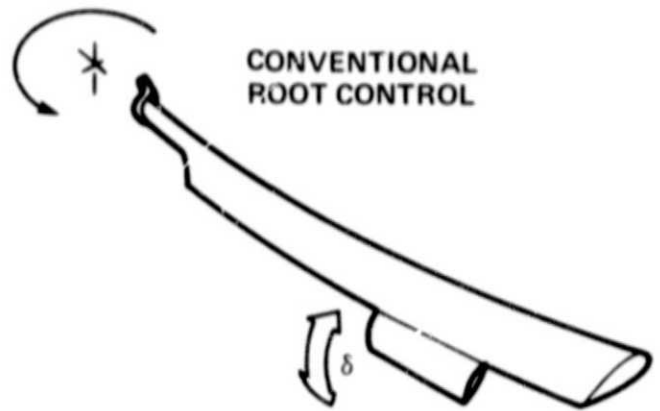

(b) CONTROLLABLE TWIST

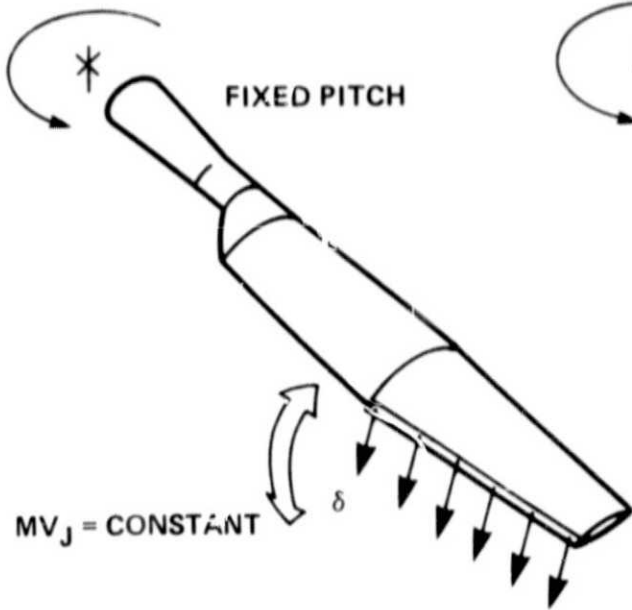

(c) PROPULSIVE JET FLAP

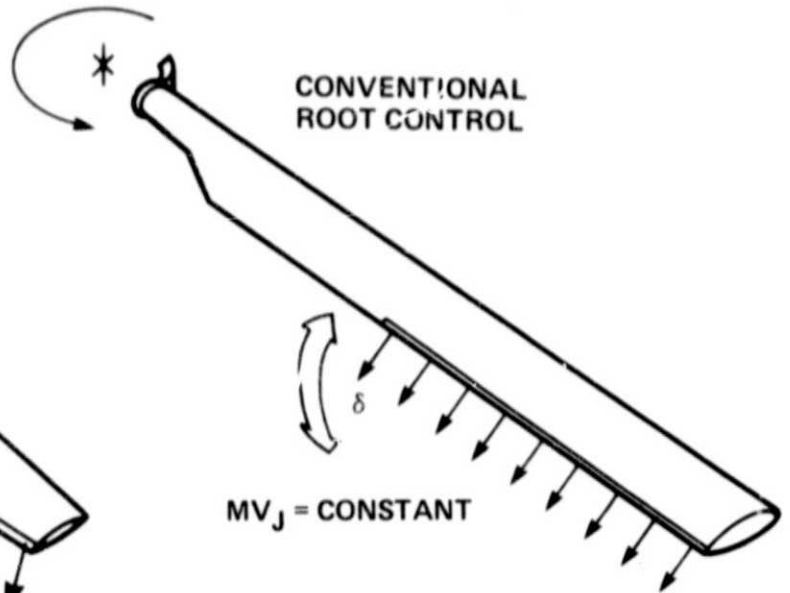

(d) NONPROPULSIVE JET FLAP

Figure 1.- Rotor types utilizing multicyclic control.

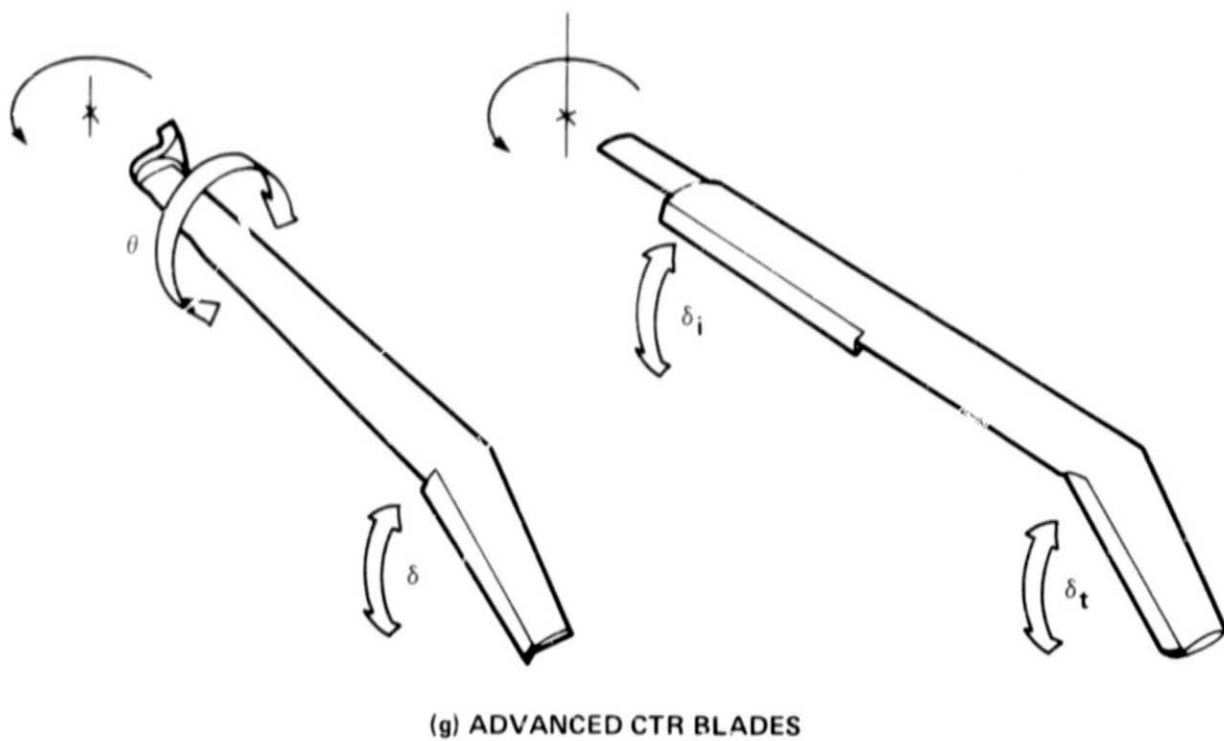
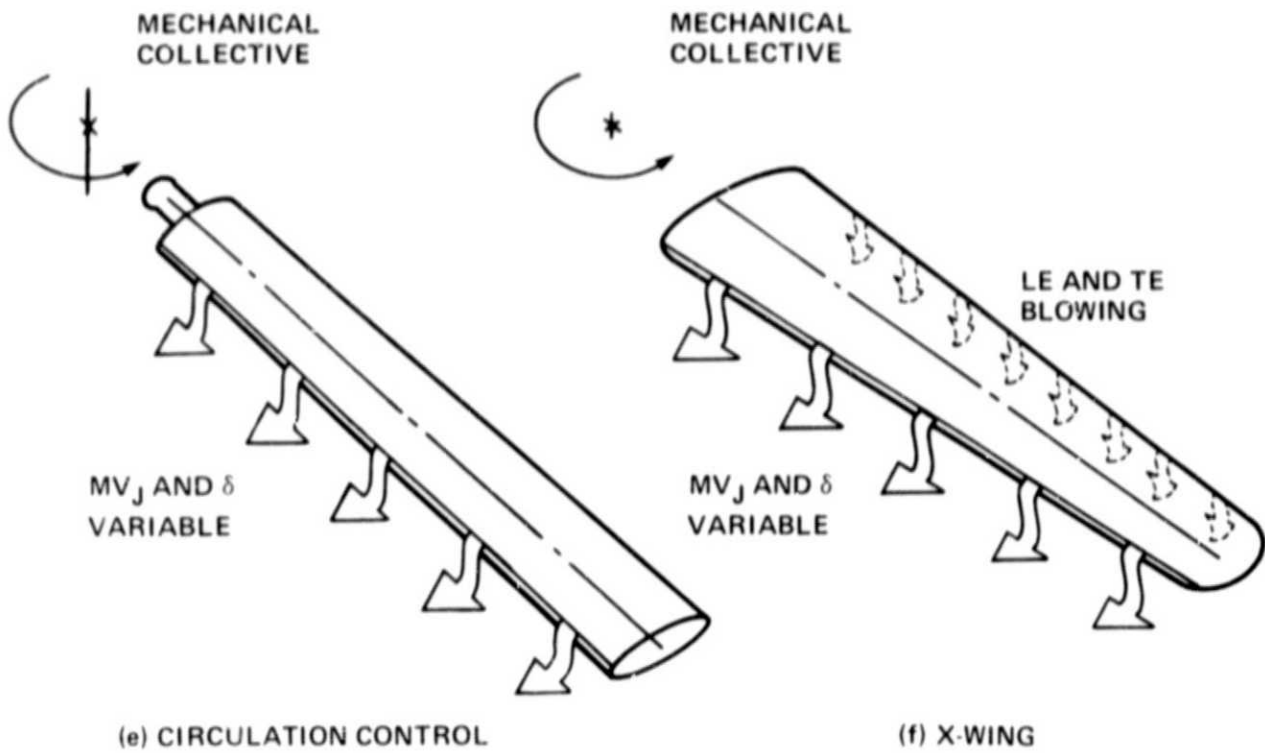
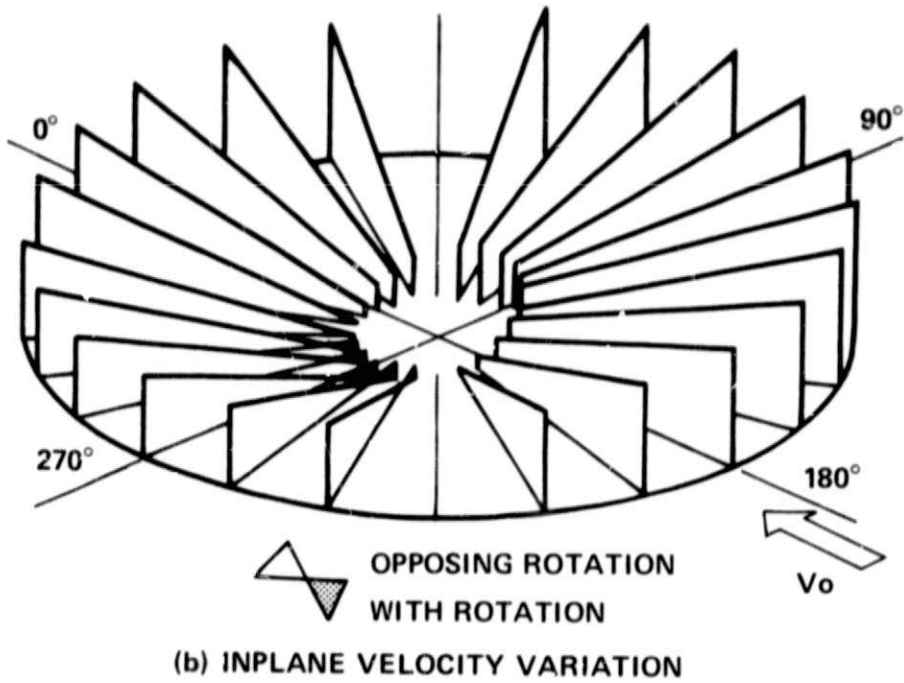
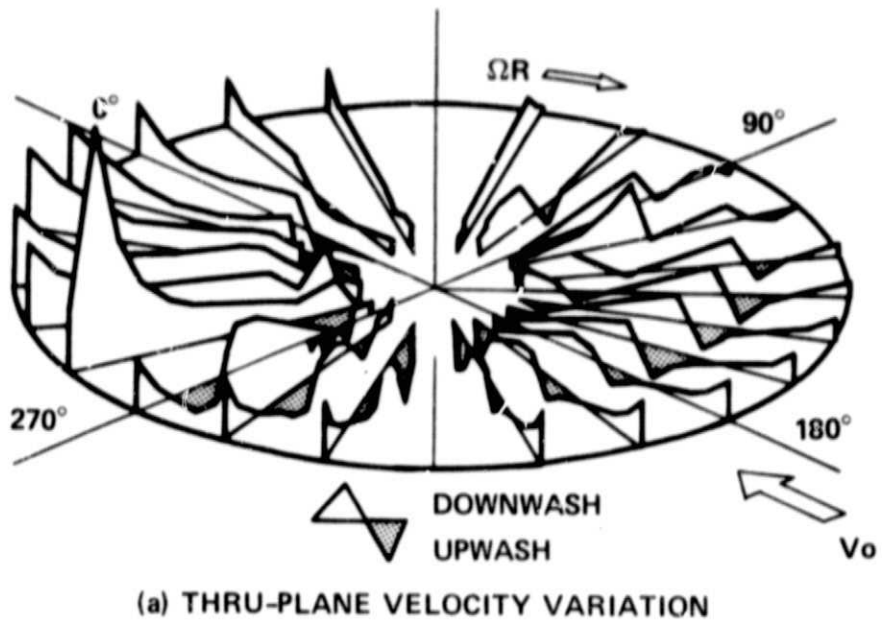

Figure 1.- Concluded.



$\mu=0.30$ 4 BLADES
 $C_{LR}/\sigma=0.08, C_{XR}/\sigma=0.003$

Figure 2.- Typical forward flight flow field components.

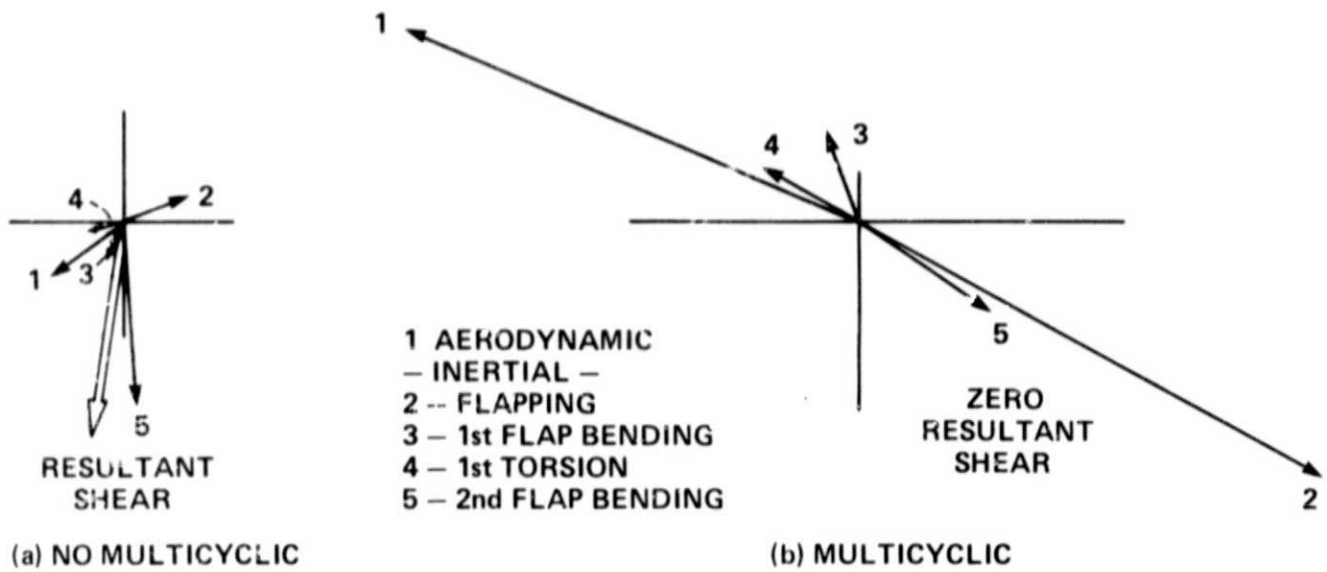

Figure 3.- Effect of multicyclic control on 5th harmonic shear components.

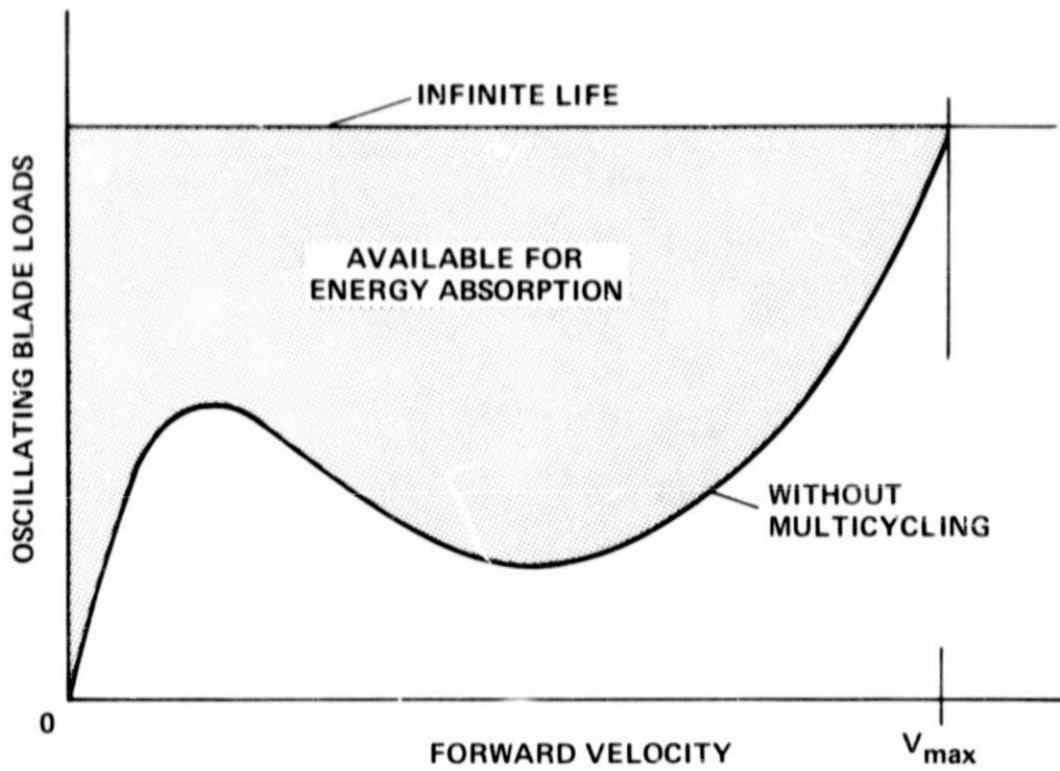
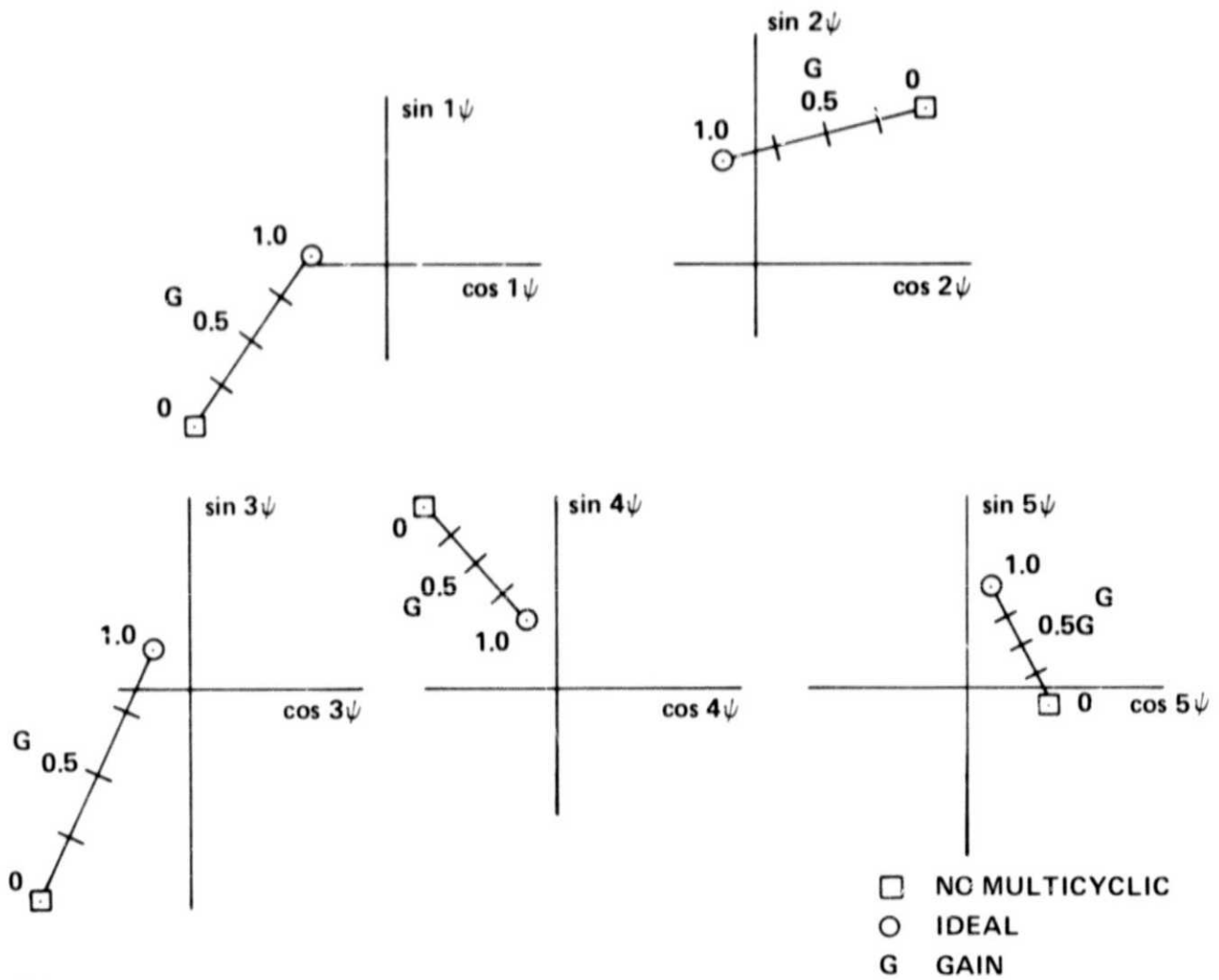

Figure 4.- Potential use of rotor blades for vibration reduction.

ORIGINAL PAGE IS
OF POOR QUALITY



a) FW- FLATWISE BENDING

Figure 5.- Effect of an ideal gain control on component loads.

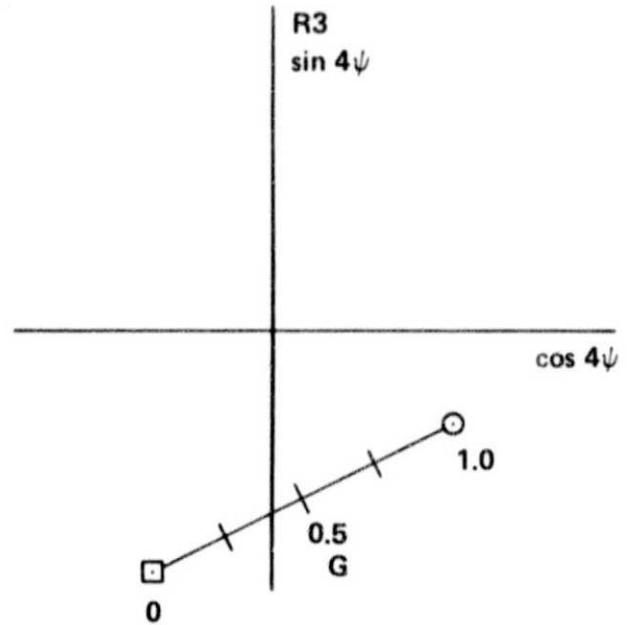
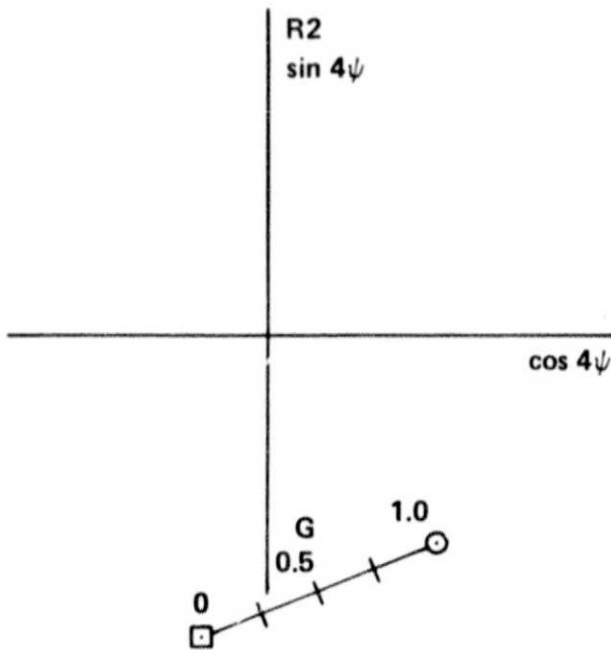
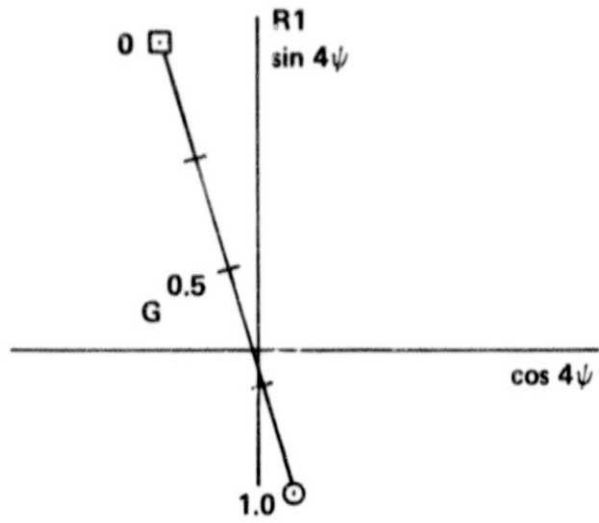

- NO MULTICYCLIC
- IDEAL
- G GAIN

b) ROOT ACTUATORS

Figure 5.- Concluded.

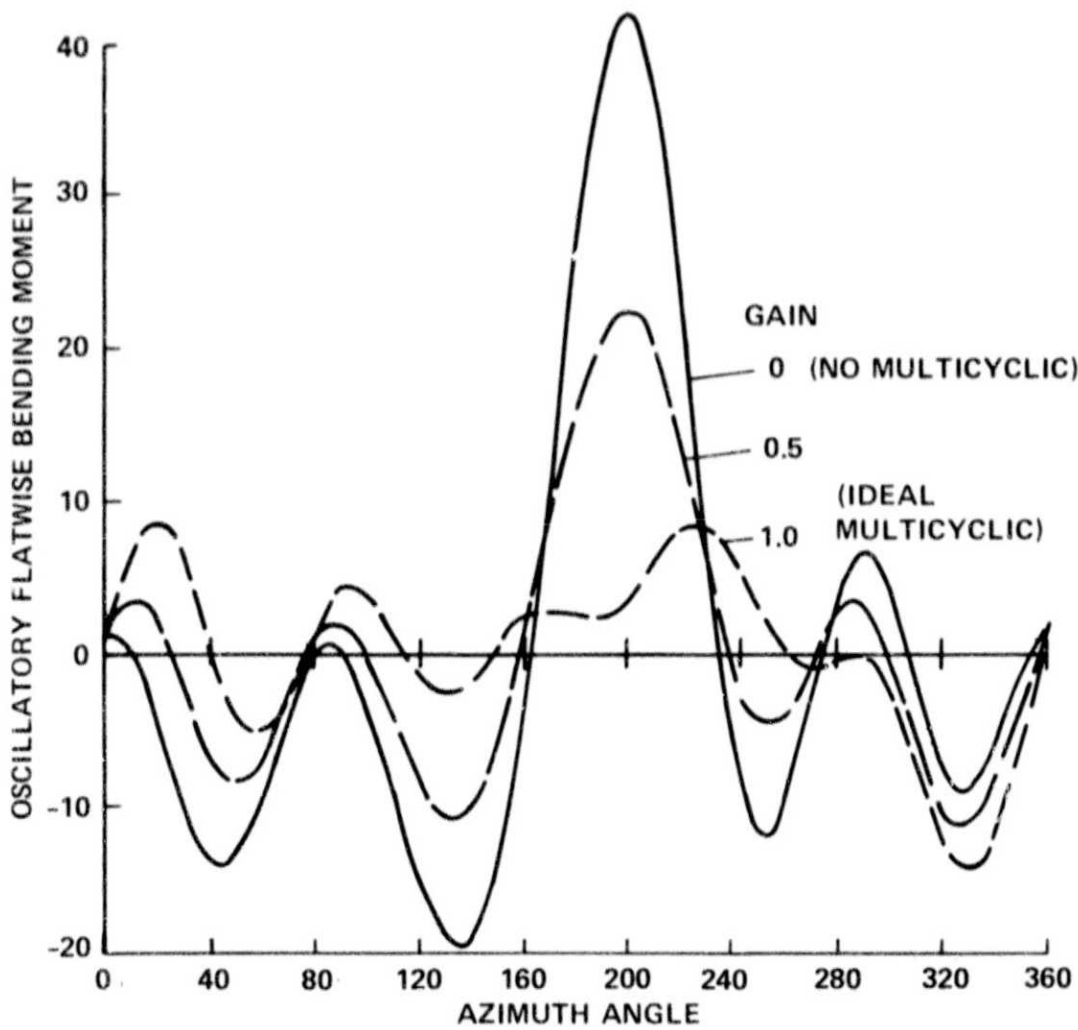

Figure 6.- Flatwise bending moment as effected by ideal gain control.

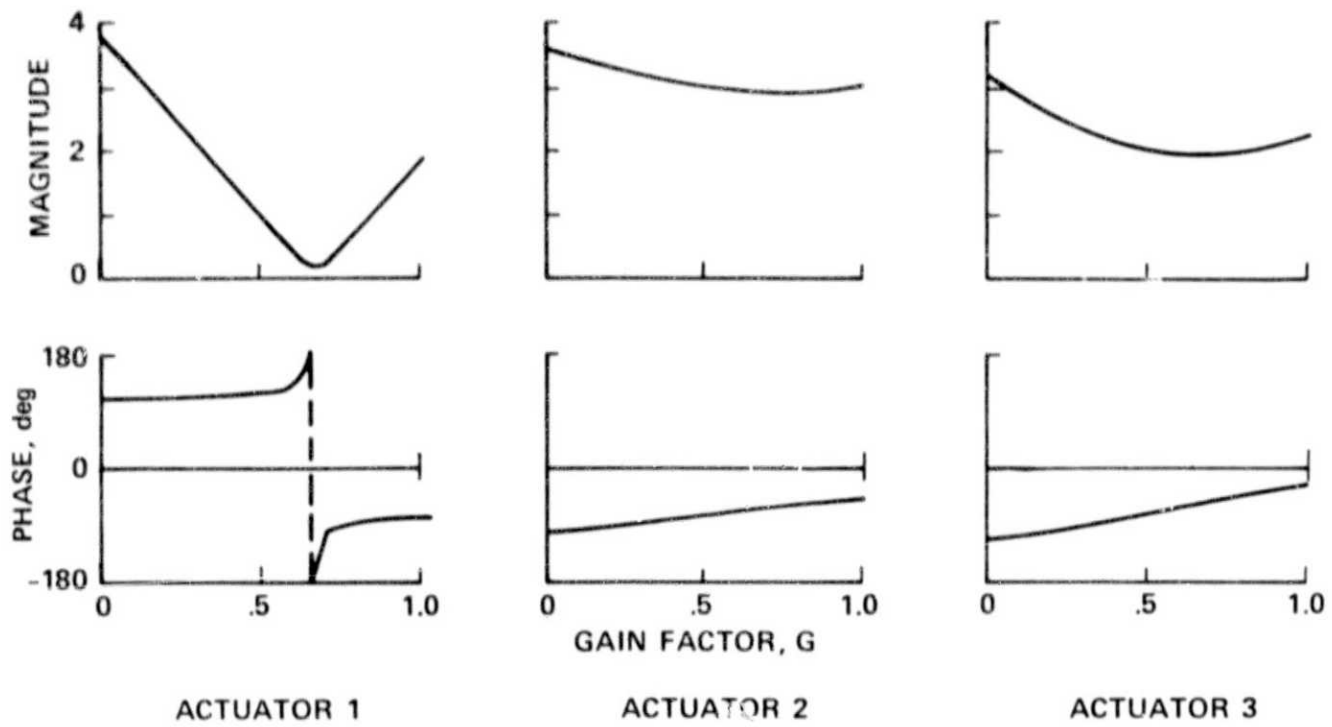

Figure 7.- Root actuators as effected by ideal gain control.

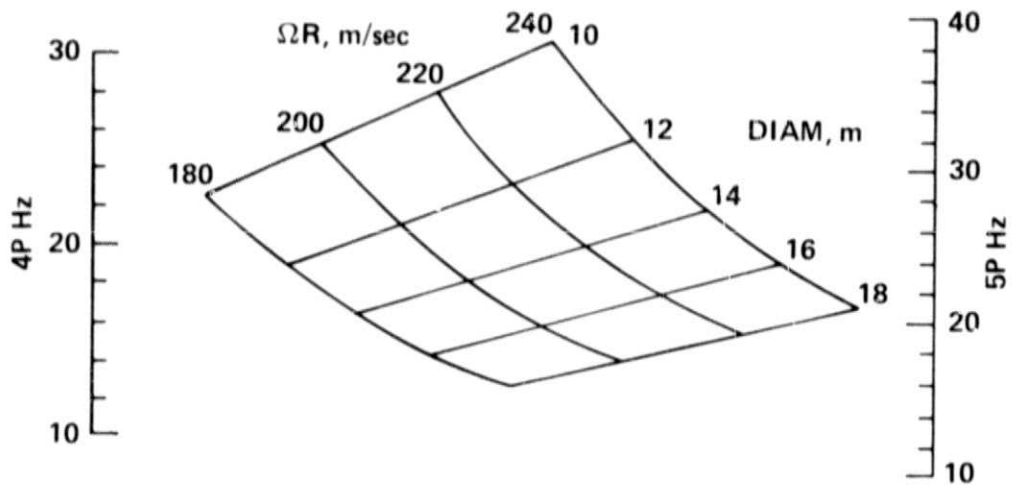

Figure 8.- Frequency requirements for multicyclic control systems.

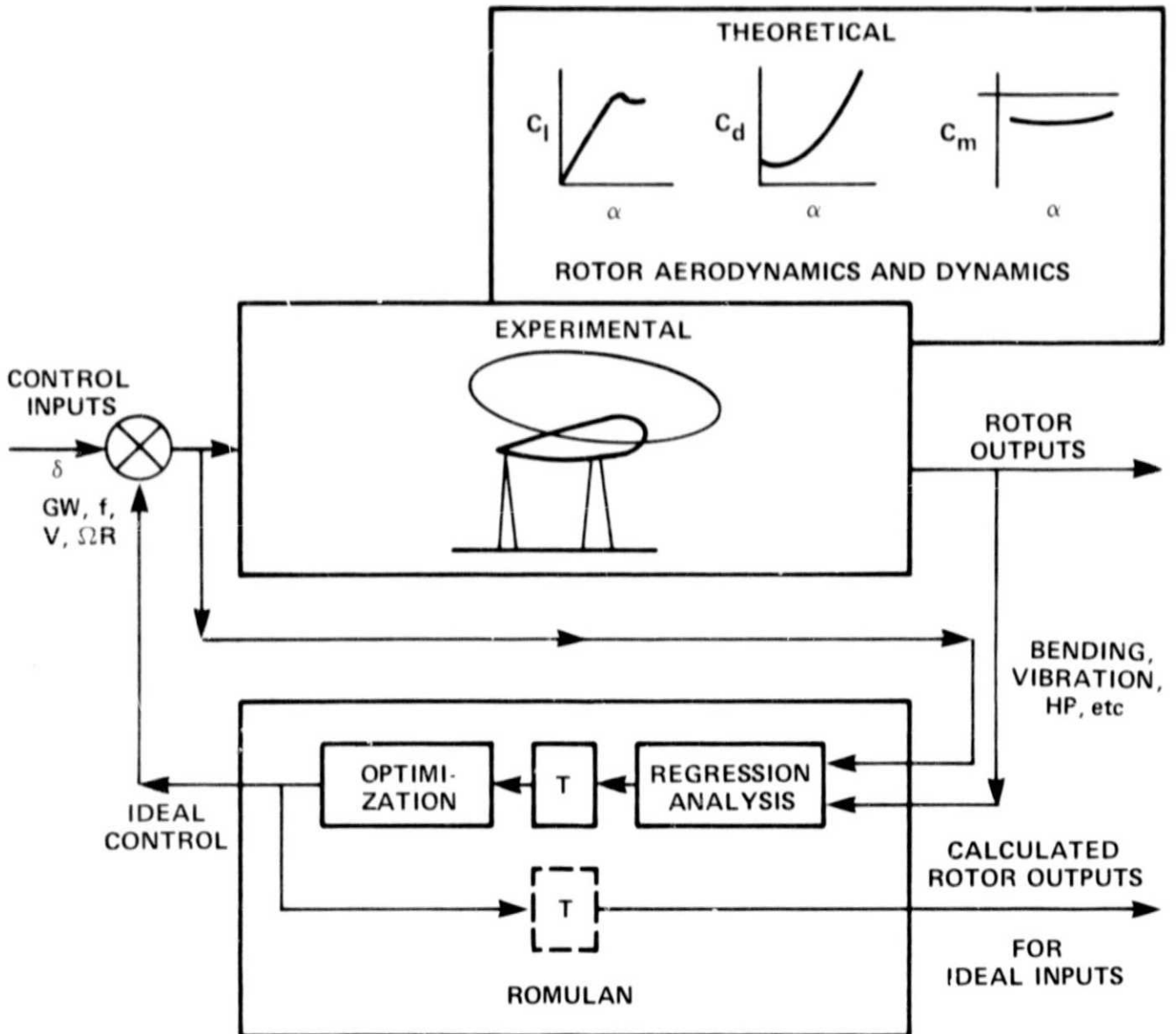

Figure 9.- An adaptive feedback control schematic.