

General Disclaimer

One or more of the Following Statements may affect this Document

- This document has been reproduced from the best copy furnished by the organizational source. It is being released in the interest of making available as much information as possible.
- This document may contain data, which exceeds the sheet parameters. It was furnished in this condition by the organizational source and is the best copy available.
- This document may contain tone-on-tone or color graphs, charts and/or pictures, which have been reproduced in black and white.
- This document is paginated as submitted by the original source.
- Portions of this document are not fully legible due to the historical nature of some of the material. However, it is the best reproduction available from the original submission.

EVALUATION OF CANDIDATE METALS IN A
SIMULATED SPACE SHUTTLE MAIN ENGINE ENVIRONMENT
FOR APPLICATION AS TURBINE BLADE DAMPERS

Prepared by

Leonard H. Caveny and Samuel O. Morris

April 1979

1. Approved for public release; distribution unlimited.
2. Reproduction in whole or in part is permitted for any purpose of the United States Government.

Final Report

Prepared for:
George C. Marshall Space Flight Center
National Aeronautics and Space Administration
Huntsville, Alabama 35812

(NASA-CR-161299) EVALUATION OF CANDIDATE
METALS IN A SIMULATED SPACE SHUTTLE MAIN
ENGINE ENVIRONMENT FOR APPLICATION AS
TURBINE BLADE DAMPERS Final Report

N79-32325

(Princeton Univ., N. J.) 37 p HC A03/MF A01 G3/26
Mechanical and Aerospace Engineering Department
Princeton University
Princeton, New Jersey 08544

Unclas

38175



TABLE OF CONTENTS

Report Documentation Page	i
Preface	ii
INTRODUCTION: PHYSICAL SITUATION	1
APPARATUS	3
RESULTS	5
Specimens	5
Successive Exposure to Wet H ₂	7
Exposure to Dry H ₂	8
CONCLUSIONS	9
RECOMMENDATIONS	9
REFERENCES	10
Tables	-
Figures	-

Preface

The technical monitor for this project was W. B. McPherson of the Marshall Space Flight Center. The apparatus and experimental techniques used in the experiments were extensions of those developed under the sponsorship of the Army Material and Mechanics Center, Watertown, Massachusetts.

INTRODUCTION: PHYSICAL SITUATION

The desired high performance of the Space Shuttle main rocket engine has lead to the consideration of improved turbine-blade damper materials for the high-pressure turbopumps. The pumps are driven by the combustion products of fuel-rich H_2/O_2 mixtures which produce wet H_2 . A recent study (Ref. 1) revealed that high-pressure, high-temperature H_2/H_2O mixtures chemically attack steel and produce mass loss rates which are much higher than can be explained by simple heating. Presently, the dampers are made of Haynes 188. Materials which are candidates to reduce turbine blade damper erosion include platinum, rhodium and stainless steels. Accordingly, the requirement exists for an accelerated means of evaluating the relative erosion resistance of the candidate materials. Also, it is desirable that the specimens used in the evaluation have a simple configuration so as to reduce the problems associated with sample preparation.

The Mechanical and Aerospace Engineering Department of Princeton University has experience in analyzing the erosion-producing effects of high temperature and high pressure gases on metals (Ref. 1 through 4). Experimental techniques have been developed to subject metal specimens to prescribed high temperature and high pressure environments by means of a ballistic compressor. The ballistic compressor apparatus utilizes a reservoir of driver gas to drive a piston which compresses adiabatically the desired test gas. In this way, the apparatus produces a quantity of hot, high-pressure gas that flows through the orifice in a test specimen mounted in the ballistic compressor endwall.

The high-shear flow produced by the ballistic compressor simulates the turbine flow environment conditions by removing protective surface layers and, thus, produces direct interactions between the test gases and the metal specimen.

The effects of repeated exposures are evaluated by subjecting a single specimen to a series of ballistic compressor exposures. In this manner, the wear-inhibiting contributions of surface scales and intergranular surface layer changes can be evaluated.

To answer questions that have been raised about the erosion producing mechanism and to explore the use of alternate materials the following tasks were performed:

1. Determine the relative erosion characteristics by subjecting specimens of four candidate metals to a range of heating conditions using a mixture of 50% hydrogen and 50% water vapor (by weight).
2. From the results of Task 1, select a moderately severe exposure condition and subject specimens of the four metals to three consecutive exposures.
3. Subject the specimen materials to dry hydrogen using conditions similar to those in Task 2.

APPARATUS

The interpretation of the gas-metal interactions in the combustion-gas experiments is always obscured to a large degree by uncertainties in knowing the gas composition and by simultaneous presence of a number of gaseous species formed by the combustion. The problems associated with interpreting the effects produced by several gaseous species (i.e., using combustion gases) were overcome by using a prescribed pure gas and prescribed gas mixtures in the ballistic compressor.

A detailed description of the ballistic compressor apparatus is given in Ref. 4. In brief, the ballistic compressor apparatus, shown schematically in Fig. 1, utilizes a reservoir of driver gas (e.g., 2.5 MPa, 300 K) to drive a piston to compress adiabatically the desired test gas. In this study, the desired water vapor weight fraction was achieved by adding a prescribed weight of water to a known volume of H₂. To insure that the water evaporated, the gas mixture was maintained above 150 F. The apparatus produces the desired hot, high pressure gas (e.g., 150 MPa, 3000 K) that flows across the specimen material. The pressure history of the test gas was monitored by a high frequency piezoelectric pressure transducer. Typical pressure traces are shown in Fig. 2. A tungsten (i.e., 97.4% W and 2.6% Ni, Cu & Fe) piston was used for this test series. The effective test time produced by the ballistic compressor is between 1 and 2 ms.

Metal test specimen mass loss (measured to 0.01 mg) is the primary quantitative data used to indicate the severity of the

gas-metal interaction during test exposure. The severity of the environment is categorized by the maximum pressure. The configuration of the metal specimen is shown in Fig. 3. The leading edge is streamlined so that the highest erosion rate does not occur at the leading edge. Figure 4 illustrates the flow and heat transfer conditions experienced by the specimen.

RESULTS

Specimens

Tests were performed on four candidate metals supplied by NASA/Marshall Space Flight Center:

- 1) Haynes Alloy 188
- 2) Stainless steel A-286
- 3) Platinum 90%/Rhodium 10% (Pt-ZGS, zirconia grain stabilized)
- 4) Rhodium

NOMINAL COMPOSITION OF CANDIDATE ALLOYS FOR TURBINE BLADE DAMPERS

%	A-286 (AMS 5731)	H-188 (AMS 5772)	ZGS Platinum, 10% Rhodium ¹	Rhodium (29Z) ¹
C	.08 *	.15 *	Pt	Balance
Mn	2.00 *	1.25 *	Rh	10.0%
Si	1.00 *	.50 *	Zr	600 ppm
P	.025*	.020*	Ag	30
S	.025*	.015*	Cu	50
Cr	14.75	22.00		30
Ni	25.50	22.00		50
Co		Balance	Si	10
Mo	1.25		Pb	40
W		14.50	Sb	30
Ti	2.13			5
Al	.35 *			5
B	.0065	.015*	Zn	30
Fe	Balance	3.00 *		50
Others	V .30	La .075	Ir, Os, Au, Low Melting Elements	10 20

* Maximum

¹ Maximum parts per million (ppm) unless otherwise noted.

Metals 1 and 2 were provided by NASA/Marshall and roughly machined by NASA to the Fig. 3 configuration. Metals 3 and 4 were provided by Massey-Bishop, Malburn, PA, and were also roughly machined by Massey-Bishop to the Fig. 3 configuration. The conditions of each of the specimens is summarized as follows:

- 1) Haynes Alloy 188: Of the 45 specimens received, none of them

were machined to the specified dimensions. After extensive remachining and selection, 15 specimens were made serviceable.

2) Stainless Steel A-286: The situation with these specimens was approximately the same as with the H-188. After extensive remachining and selection, 15 specimens were made serviceable. The specimens had surface crazes and cracks.

3) Platinum/Rhodium specimens: These 15 specimens were received in reasonably good condition with respect to machining. However, they had to be touched-up so that they would fit into the test section of the ballistic compressor.

4) Rhodium: These 15 specimens had easily observed networks of crazes.

As a basis of comparison with previous results obtained for the Army Material and Mechanics Center, tests were performed with:

5) AISI 4340 (Annealed)

6) Iron (99.9% Pure)

These specimens were of good quality and machined at Princeton University.

The results in the Tables 1a through 1e are the data obtained by exposing all four candidate metals to a single exposure of the 50% H₂ and 50% H₂O mixture (by weight). An additional series (Table 1f) was run using AISI-4340 and Fe since these metals were known to produce uniform results (Ref. 1 through 4). The Table 1f data were

also reported to the Army Material and Mechanics Center.

The Table 1 data are plotted in Figs. 5, 6, 7 and 8. The most striking observation is the scatter of the four candidate metals compared to AISA-4340 and Fe. Based on casual examination of the surfaces of the candidate metals, this scatter is probably a direct result of inhomogeneities in the metal. The lines through the data points were placed through the data representative of minimum erosion since it is believed that those data are most representative of the homogenous material.

The results indicate that Rh is the most resistant and that there are no clearly defined differences among H-188, A-286 and Pt.

Successive Exposure to Wet H₂

To obtain data on how successive exposures affect mass loss, a series of experiments were performed in which specimens of each candidate metal were subjected to three (or more) exposures.

From the three successive exposure tests the following observation can be made (from the average of four specimens of a particular metal):

- 1) The erosion from initial exposure (at approximately 21.5 kpsi) was low (average ranged from 0.00 to 0.15 mg) for all four metals.

- 2) The erosion from the second exposure (at approximately 25 kpsi) was considerably higher than the first exposure.

3) The erosion from the third exposure (at the highest pressure of approximately 30 kpsi) produced considerably less erosion than the second exposure.

An examination of the tabulated data (Tables 2a through 2e) indicates that the alternate and decreasing of erosion is more than coincidental. To obtain more information on this observation a fourth exposure was made using the H-188 specimens; the data tabulated in Table 2a reveal that fourth exposure produces results similar to the second in that it produced high erosion. A possible explanation for these observations is that surface layers are alternately built up and swept away. The surface layers may offer some intermediate protection. From the results of the successive exposure series Rh is clearly the most resistant material. However, examination of the total mass loss from the successive exposure series does not reveal any clearly defined differences among H-188, A-286 and Pt.

An additional successive exposure series was run using four metals at a time, see Table 2e. That series also indicates that Rh is the most resistant and that the other three metals are nearly equivalent.

Exposures to Dry H₂

As a point of comparison, the metals were exposed to dry H₂, see Tables 3a and b. Our previous investigations revealed that dry H₂ is a very severe environment since it produces very high

convective heat fluxes. Accordingly, the erosion produced by dry H₂ was expected to be comparable to that produced by wet H₂. The most resistant metals were Pt and Rh, whereas, H-188 and A-286 experience appreciable mass losses.

CONCLUSIONS

The four candidate metals H-188, A-286, Pt and Rh were subjected to a wet H₂ environment which produced accelerated erosion effects. To some extent the uniformity of the results was degraded by the poor quality of the metal specimens. However, Rh was clearly the most resistant material and the differences among H-188, A-286 and Pt are not clearly defined.

The tests using specimens of good quality material produced uniform and consistent results. The results from this study suggest that a portion of the mass loss is attributable to defects in the metals. Accordingly, the results indicate that difficulties experienced by the operational components made from H-188 may be attributable also to metallurgical defects.

RECOMMENDATIONS

The scope of this investigation did not provide for metallurgical examination of the bulk material and scanning electron microscope examination of the eroded surfaces. Such examinations are needed to determine the extent to which metallurgical defects influenced the results.

REFERENCES

1. Gany, A., Caveny, L. H. and Johnson, J. W., "Effect of Water Vapor on Erosion of Steel by High Temperature Flows", to appear in Non-Equilibrium Interfacial Transport Processes, ASME, 1979.
2. Gany, A., Caveny, L. H. and Summerfield, M., "Aerothermochemistry of Metal Erosion by Hot Reactive Gases", Journal of Heat Transfer, Transactions of ASME, Vol. 100, No. 3, Aug. 1978, pp. 531-536.
3. Caveny, L. H., Gany, A., Summerfield, M. and Johnson, J. W., "Effect of Propellant Type on Steel Erosion", Proceedings of JANNAF Propulsion Conference, February 1978, CPIA Publication 293, Vol. V, pp. 285-299.
4. Alkidas, A. C., Christoe, C. W., Caveny, L. H. and Summerfield, M., "Erosive Effects of High Pressure and High Temperature Pure Gases on Steel", Journal of Engineering Materials and Technology, Transactions of ASME, Vol. 99, Series H, No. 3, July 1977, pp. 239-243.

Table 1a

Haynes Alloy 188 Subjected to Single Exposure

50% Hydrogen & 50% Water Vapor (by weight)

Test Series 78-1,-3,-10,-12&-13

COMPRESSOR PORT

TEST No.	PRESS kpsi	COMPRESSOR PORT								DRIVER psig
		ONE	TWO	THREE	FOUR					
		METAL m,mg	METAL m,mg	METAL m,mg	METAL m,mg					
1-6	37.0	[H-188 2.60]								300
3-1	24.5	H-188 0.11	H-188 0.62	H-188 0.17	H-188 0.90				300	
3-2	28.5	H-188 0.65	H-188 0.46	H-188 1.29	H-188 1.53				300	
3-3-1	20.0	H-188 0.19								
3-3-2	20.0	H-188 0.19								
3-3-3	19.0	H-188 0.10								300
10-1	21.5	[H-188 0.28]	H-188 0.00	H-188 0.08	H-188 0.00				280	
12-1	20.0			H-188 0.35					300	
12-2	26.0			H-188 N.G.					300	
13-1	25.5			H-188 0.45					270	

* Test result in brackets differs substantially from mean and is not included in the averages and the plots.

Note explaining table:

The numbers in the heading designate the particular port in the four-port head. For each port the material and mass loss, m, are designated.

Table 1b

Stainless Steel (A-286) Subjected to Single Exposure

50% Hydrogen & 50% Water Vapor (by weight)

Test Series 78-2 & 5

COMPRESSOR PORT

TEST No.	PRESS kpsi	ONE		TWO		THREE		FOUR		DRIVER psig	AVERAGE m,mg
		METAL	m,mg	METAL	m,mg	METAL	m,mg	METAL	m,mg		
2-2	37.0	[A-286 3.78]								300	
5-1A	25.5	A-286	0.16	A-286	0.08	A-286	0.16	[A-286 0.67]		300	0.13
5-1	35.0	A-286	1.04	A-286	0.55	[A-286 1.34]		A-286	0.56	300	0.15
11-1	21.5	A-286	0.09	A-286	0.03	A-286	0.02	[A-286 0.36]		280	0.05
12-1	20.0							A-286	0.38	300	
12-2	26.0							A-286	0.88	300	
13-1	25.5							A-286	0.46	270	

+ Test result in brackets differs substantially from mean and is not included in the averages and the plots.

Table 1c

Platinum (Pt-ZGS) Subjected to Single Exposure

50% Hydrogen & 50% Water Vapor (by weight)

Test Series 18-2 & misc.

COMPRESSOR PORT

TEST No.	PRESS kpsi	ONE		TWO		THREE		FOUR		DRIVER psig	AVERAGE m,mg
		METAL	m,mg	METAL	m,mg	METAL	m,mg	METAL	m,mg		
78-1	12.0	PT-1	0.12							300	
2-2	35.0	PT-3	0.20							300	
8-1	22.5	PT-4	0.14	PT-5	0.12	PT-6	0.19	[PT-7	0.36]	280	0.15
2-2	35.5	PT-2	0.00							300	
12-1	20.0	PT	0.39							300	
12-2	26.0	PT	0.71							300	
13-1	25.5	PT	0.36							270	

* Test result in brackets differs substantially from mean and is not included in the averages and the plots.

Table 1d

Rhodium (Rh-29Z) Subjected to Single Exposure

50% Hydrogen & 50% Water Vapor (by weight)

COMPRESSOR PORT

TEST No.	PRESS kpsi	ONE		TWO		THREE		FOUR		DRIVER psig
		METAL	m,mg	METAL	m,mg	METAL	m,mg	METAL	m,mg	
78-1	38.0	RH-1	0.04							300
9-1	21.5	RH-2	0.00	RH-3	0.00	RH-4	0.00	RH-5	0.00	280
12-1	20.0			RH	0.00					300
12-2	26.0			RH	0.12					300
13-1	25.5			RH	0.04					270

Table 1e

Four Metals Subjected to Single Exposure
50% Hydrogen & 50% Water Vapor (by weight)
Test Series 78-12

COMPRESSOR PORT

TEST No.	PRESS kpsi	ONE		TWO		THREE		FOUR		DRIVER psig
		METAL	m,mg	METAL	m,mg	METAL	m,mg	METAL	m,mg	
12-1	20.0	PT	0.39	RH	0.00	H-188	0.35	A-286	0.38	300
12-2	26.0	PT	0.71	RH	0.12	H-188	N.G.	A-286	0.88	300

Table 1f
 Iron and AISI 4340 Subjected to Single Exposure
 50% Hydrogen & 50% Water Vapor (by weight)
 Test Series 78-4 & 6

COMPRESSOR PORT

TEST No.	PRESS kpsi	ONE		TWO		THREE		FOUR		DRIVER psig	AVERAGE m,mg
		METAL	m,mg	METAL	m,mg	METAL	m,mg	METAL	m,mg		
4-1	26.0	4340	0.15	4340	0.12	4340	0.16	4340	0.11	300	0.14
4-2	22.0	4340	0.00	4340	0.03	4340	0.06	4340	0.04	290	0.03
4-3	32.5	4340	0.27	[4340	0.02]	4340	0.39	4340	0.37	300	0.34
6-1	27.0	FE	0.16	FE	0.14	FE	0.21	FE	0.21	300	0.18

* Test result in brackets differs substantially from mean and is not included in the averages and the plots.

Table 2a

Haynes Alloy 188 Subjected to Four Successive Exposures

50% Hydrogen & 50% Water Vapor (by weight)

Test Series 78-10

COMPRESSOR PORT

TEST No.	PRESS kpsi	ONE		TWO		THREE		FOUR		DRIVER psig	AVERAGE m,mg
		METAL	m,mg	METAL	m,mg	METAL	m,mg	METAL	m,mg		
10-1	21.5	[H-188	0.28]	H-188	0.00	H-188	0.08	H-188	0.00	280	0.03
10-2	25.0	H-188	0.37	[H-188	0.82]	H-188	0.05	H-188	0.35	290	0.26
10-3	29.5	[H-188	0.61]	H-188	0.00	H-188	0.00	H-188	0.00	300	0.00
Total			1.26		0.82		0.13		0.35		
Average 25.3											
10-4	27.0	H-188	0.49	H-188	0.43	[H-188	0.00]	H-188	0.43	300	0.45

* Test result in brackets differs substantially from mean and is not included in the averages and the plots.

Table 2b

Stainless Steel (A-286) Subjected to Three Successive Exposures

50% Hydrogen & 50% Water Vapor (by weight)

Test Series 78-11

COMPRESSOR PORT

TEST No.	PRESS kpsi	ONE		TWO		THREE		FOUR		DRIVER psig	AVERAGE m,mg
		METAL	m,mg	METAL	m,mg	METAL	m,mg	METAL	m,mg		
11-1	21.5	A-286	0.09	A-286	0.03	A-286	0.02	[A-286	0.36]	280	0.05
11-2	24.5	A-286	0.38	A-286	0.12	A-286	0.15	A-286	0.33	290	0.25
11-3	29.5	A-286	0.09	[A-286	0.40]	A-286	0.08	A-286	0.06	300	0.08
TOTAL			0.56		0.55		0.25		0.75		

Average 25.2

* Test result in brackets differs substantially from mean and is not included in the averages and the plots.

Table 2c

Platinum (Pt-ZCS) Subjected to Three Successive Exposures

50% Hydrogen & 50% Water Vapor (by weight)

Test Series 78-8

COMPRESSOR PORT

TEST No.	PRESS kpsi	COMPRESSOR PORT				DRIVER psig	AVERAGE m,mg
		ONE METAL m,mg	TWO METAL m,mg	THREE METAL m,mg	FOUR METAL m,mg		
8-1	22.5	PT-4 0.14	PT-5 0.12	PT-6 0.19	[PT-7 0.36]	280	0.15
8-2	26.5	PT-4 0.27	PT-5 0.28	PT-6 0.29	PT-7 0.30	290	0.29
8-3	30.0	PT-4 0.13	PT-5 0.15	PT-6 0.16	PT-7 0.13	300	0.14
Total		0.54	0.55	0.64	0.78		

Average 26.3

+ Test result in brackets differs substantially from mean and is not included in the averages and the plots.

Table 2d

Rhodium (Rh-292) Subjected to Three Successive Exposures

50% Hydrogen & 50% Water Vapor (by weight)

Test Series 78-9

COMPRESSOR PORT

TEST No.	PRESS kpsi	ONE		TWO		THREE		FOUR		DRIVER psig	AVERAGE m,mg
		METAL	m,mg	METAL	m,mg	METAL	m,mg	METAL	m,mg		
9-1	21.5	RH-2	0.00	RH-3	0.00	RH-4	0.00	RH-5	0.00	280	0.00
9-2	26.0	RH-2	0.00	RH-3	0.00	RH-4	0.00	RH-5	0.00	290	0.00
9-3	31.5	RH-2	0.00	RH-3	0.00	RH-4	0.00	RH-5	0.00	300	0.00
Total			0.00		0.00		0.00		0.00		

Average 26.3

Table 2e

Four Metals Subjected to Three Successive Exposures

50% Hydrogen & 50% Water Vapor (by weight)

Test Series 78-13

COMPRESSOR PORT

TEST No.	PRESS kpsi	ONE		TWO		THREE		FOUR		DRIVER psig
		METAL	m,mg	METAL	m,mg	METAL	m,mg	METAL	m,mg	
13-1	25.5	PT	0.36	RH	0.04	H-188	0.45	A-286	0.46	270
13-2	22.0	PT	0.31	RH	0.00	H-188	0.10	A-286	0.22	270
13-3	25.0	PT	0.45	RH	0.13	H-188	0.49	A-286	0.65	275
Total			.12		0.17		1.04		1.33	
Average 24.4										

Table 3a

Pair of H-188 and A-286 Subjected to Single Exposure of Dry Hydrogen
Test Series 78-15

COMPRESSOR PORT										
TEST	PRESS	ONE		TWO		THREE		FOUR		DRIVER
No.	kpsi	METAL	m,mg	METAL	m,mg	METAL	m,mg	METAL	m,mg	psig
15-1	22.5	H-188	0.86	H-188	0.89	A-286	1.22	A-286	1.36	290
Average		0.87				1.29				

Table 3b

Four Metals Subjected to Three Successive Exposures of Dry Hydrogen

Test Series 78-14

COMPRESSOR PORT								
TEST	PRESS	ONE		TWO		THREE	FOUR	DRIVER
No.	kpsi	METAL	m,mg	METAL	m,mg	METAL	m,mg	psig
14-1	23.0	PT		RH		H-188	A-286	280
14-2	23.0							285
14-3	23.0							290
Total			0.23		0.19		1.19	2.32
Average			0.08		0.06		0.40	0.77

BALLISTIC COMPRESSOR
SHOWING TEST DISK
AT END WALL

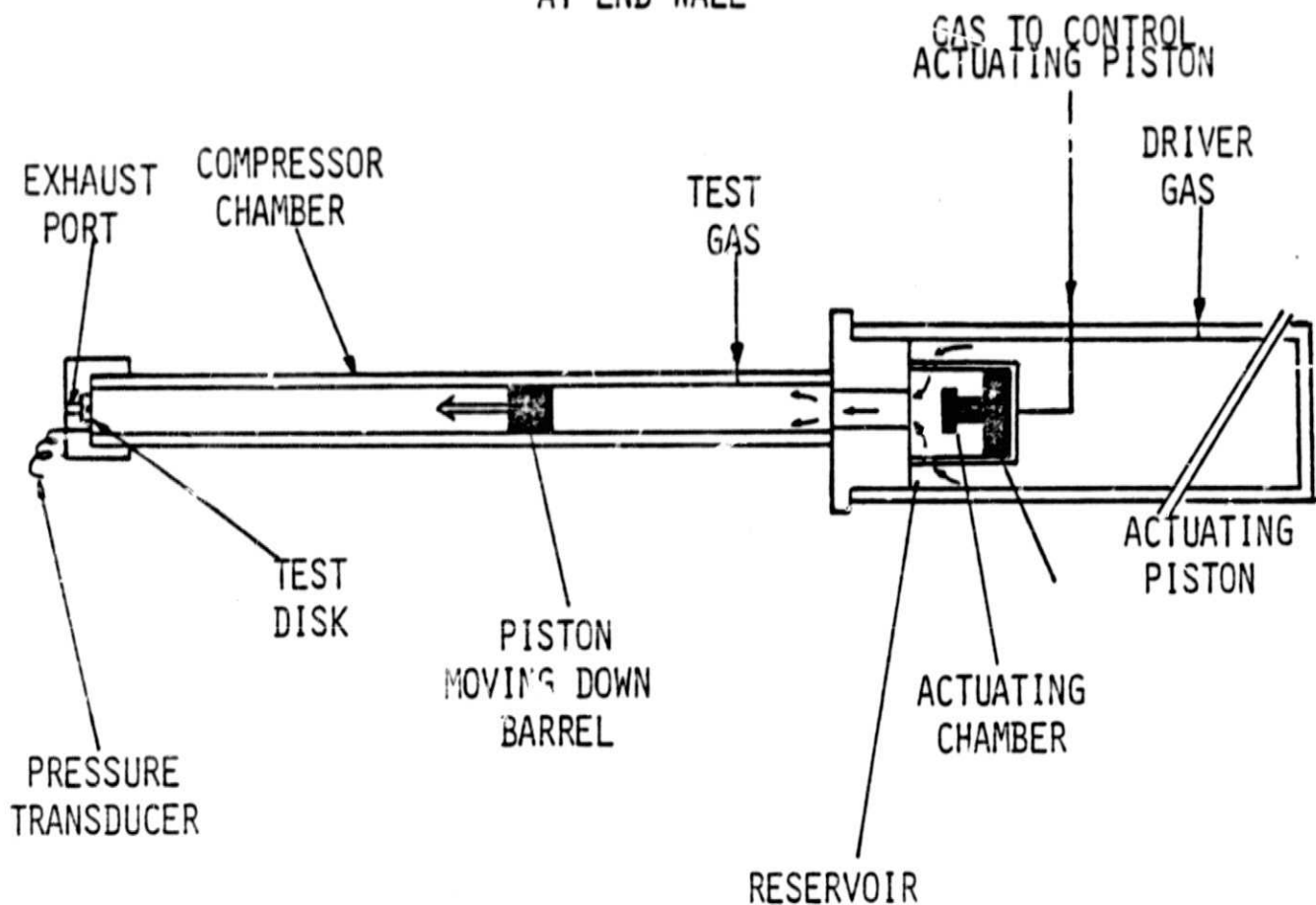
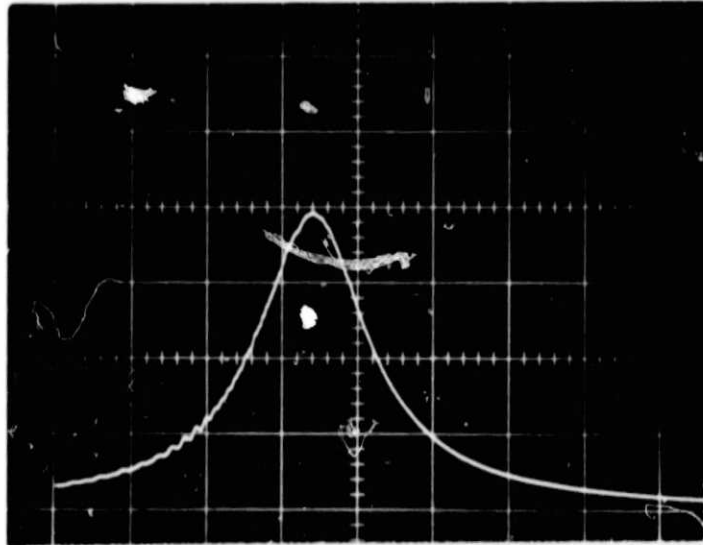
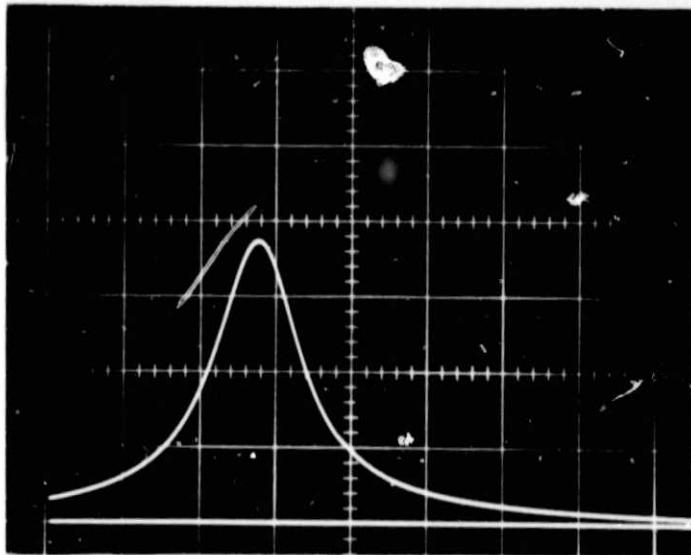

Fig. 1 Schematic diagram of the ballistic compressor showing test disk at end wall.



A) 10 KPSI/CM
0.2 MS/CM
AISA 304 PISTON (5.9 LB)
TIME ABOVE 20,000 PSI = 0.36 MS



B) 10 KPSI/CM
0.5 MS/CM
W PISTON (14.3 LB)
TIME ABOVE 20,000 PSI = 0.66 MS

ORIGINAL PAGE IS
OF POOR QUALITY

Fig. 2 Typical pressure versus time traces produced by ballistic compressor (the tungsten, W, piston was used in this test series).

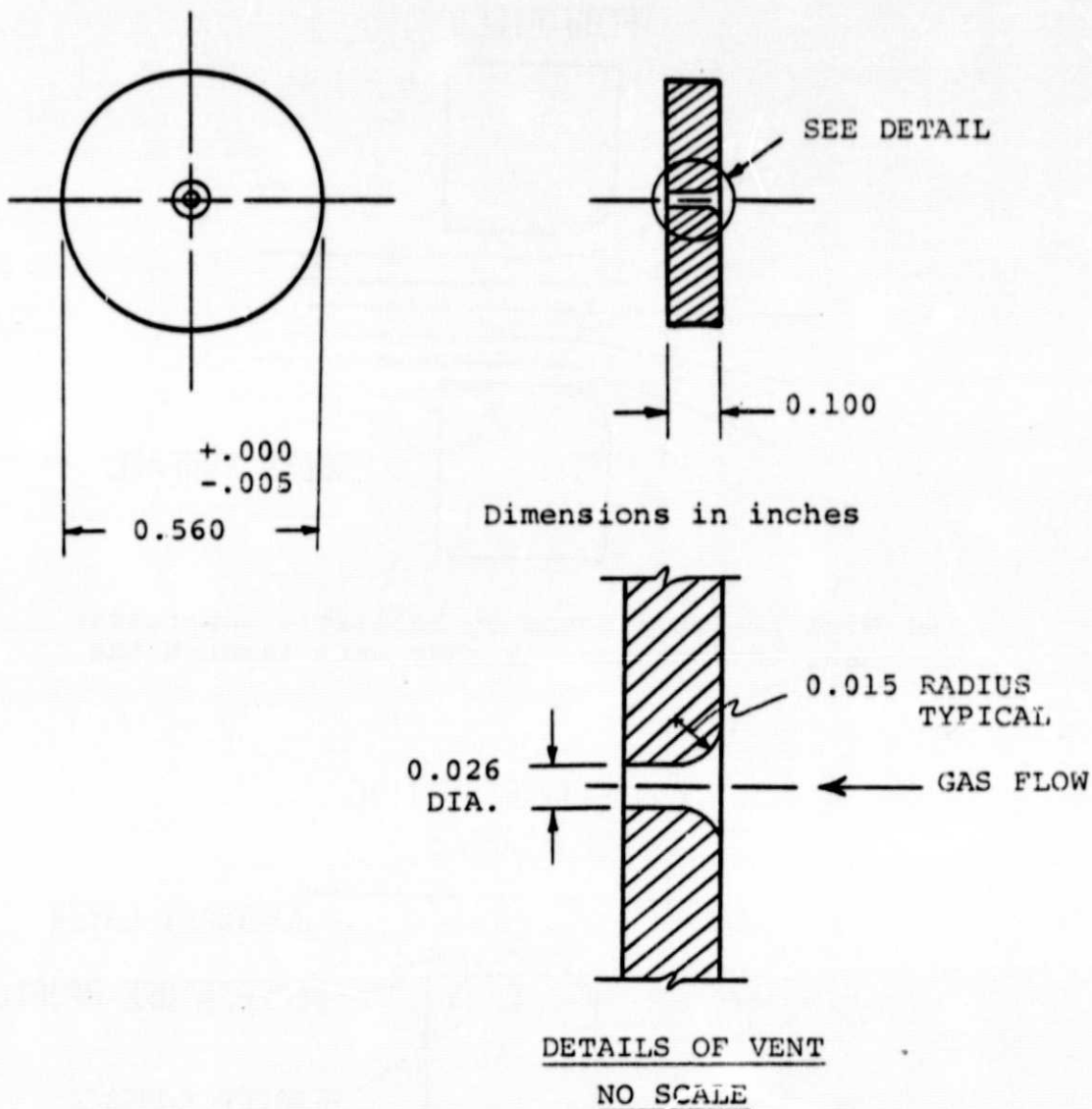
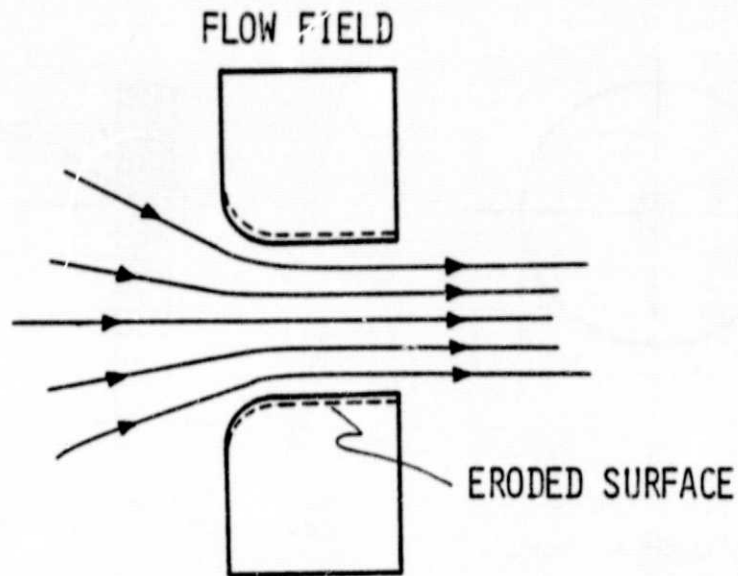

Fig. 3 Configuration of test specimen used in endwall of ballistic compressor.

EXPOSURE CONDITIONS



- a) High pressure gases in ballistic compressor heat the specimen as they vent through the orifice.

CONVECTIVE HEATING
OF SURFACE

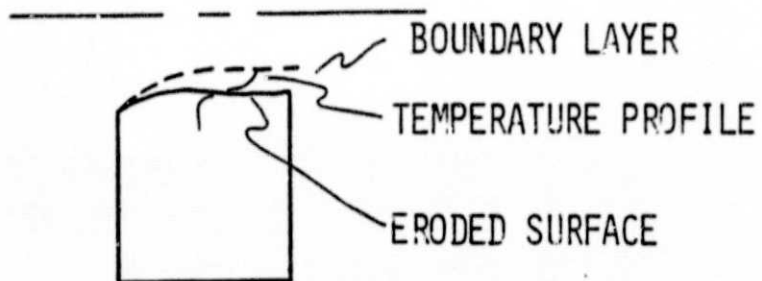

- b) Transient forced convection heats a thin surface layer of the specimen; the boundary layer is generally thin compared to the dimensions of the orifice.

Fig. 4 Exposure conditions of test specimens.

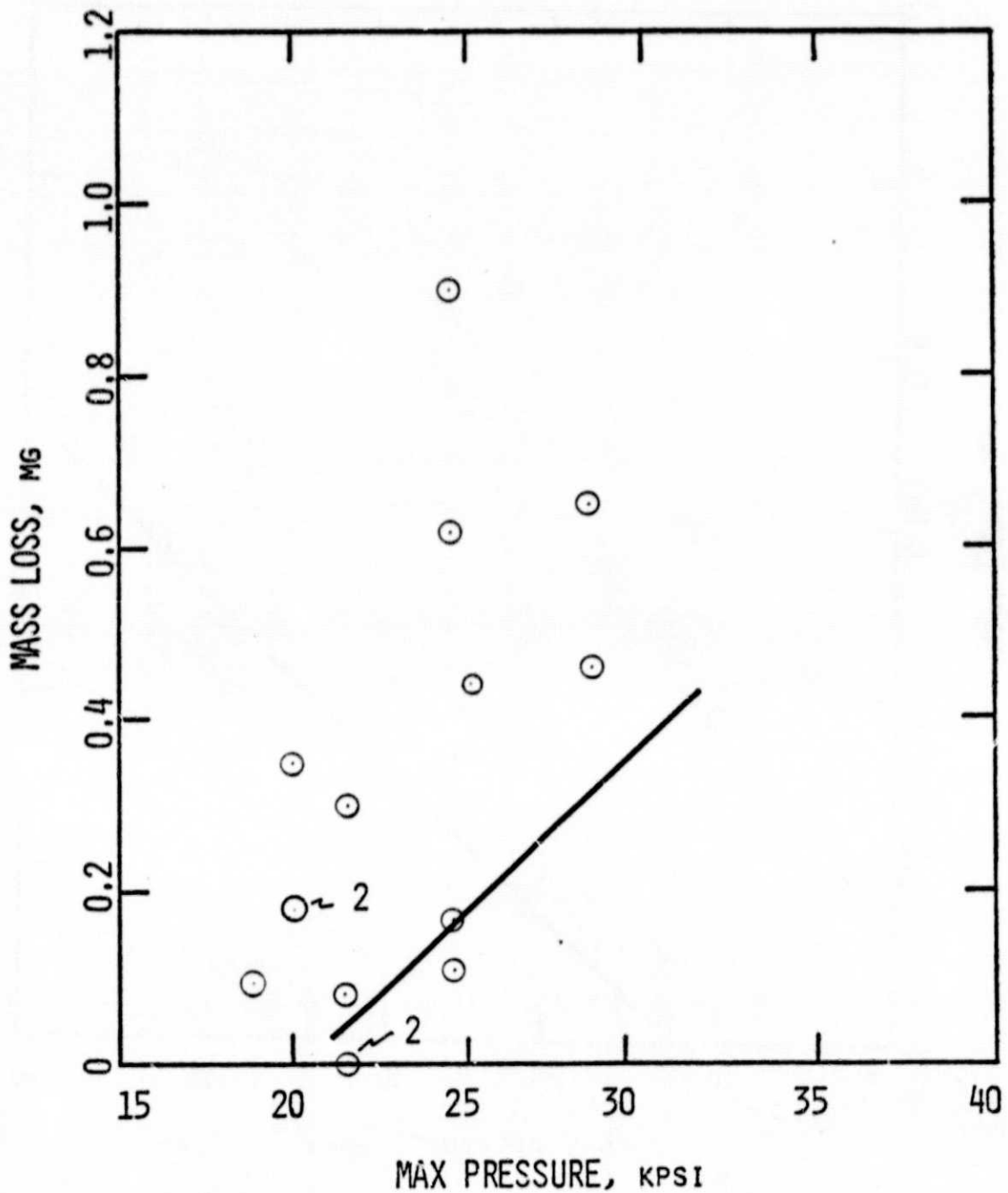

Fig. 5 H-188 mass loss resulting from single exposure to wet H₂. Line is intended to approximate minimum erosion conditions.

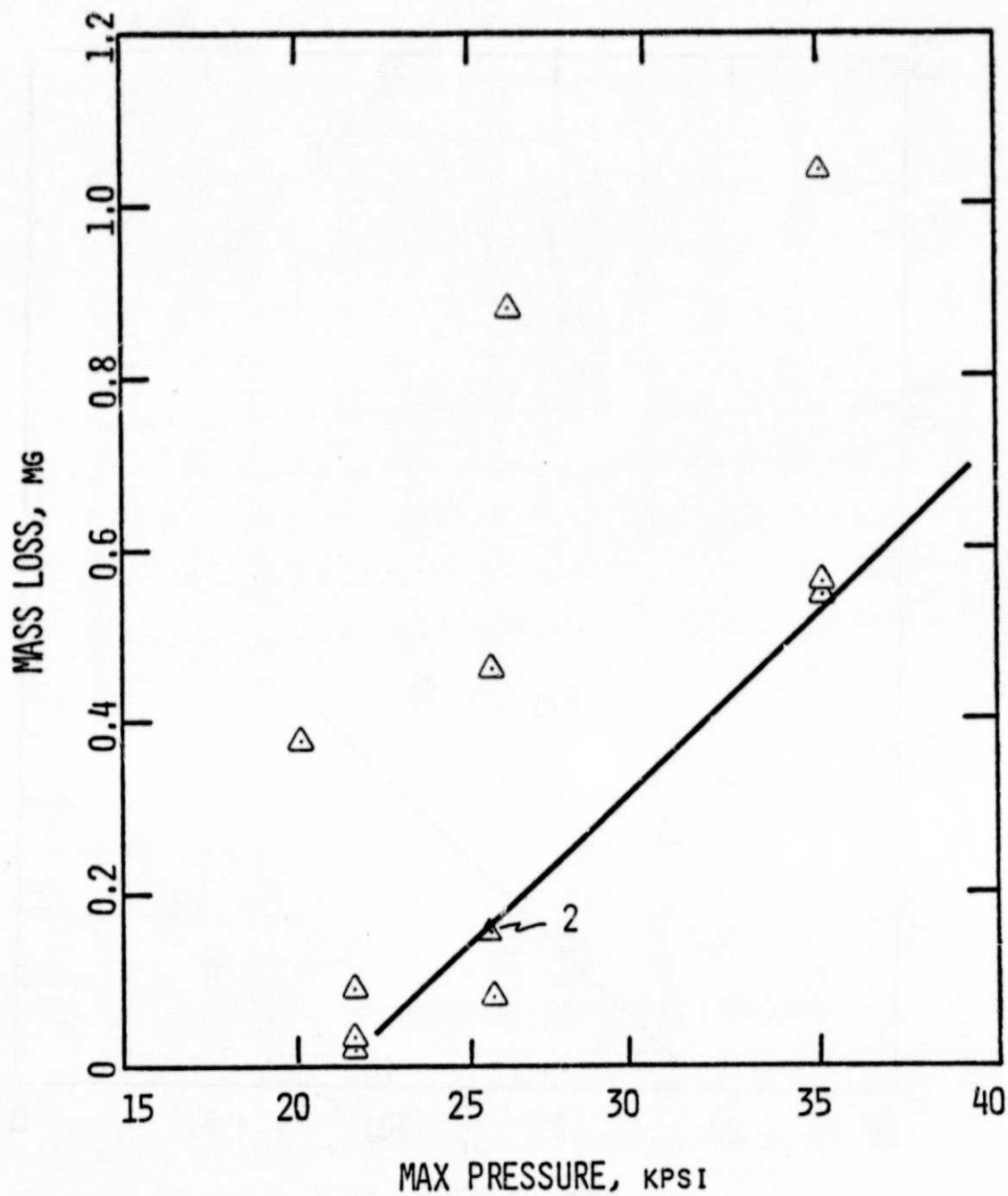

Fig. 6 A-286 mass loss resulting from single exposure to wet H₂. Line is intended to approximate minimum erosion conditions.

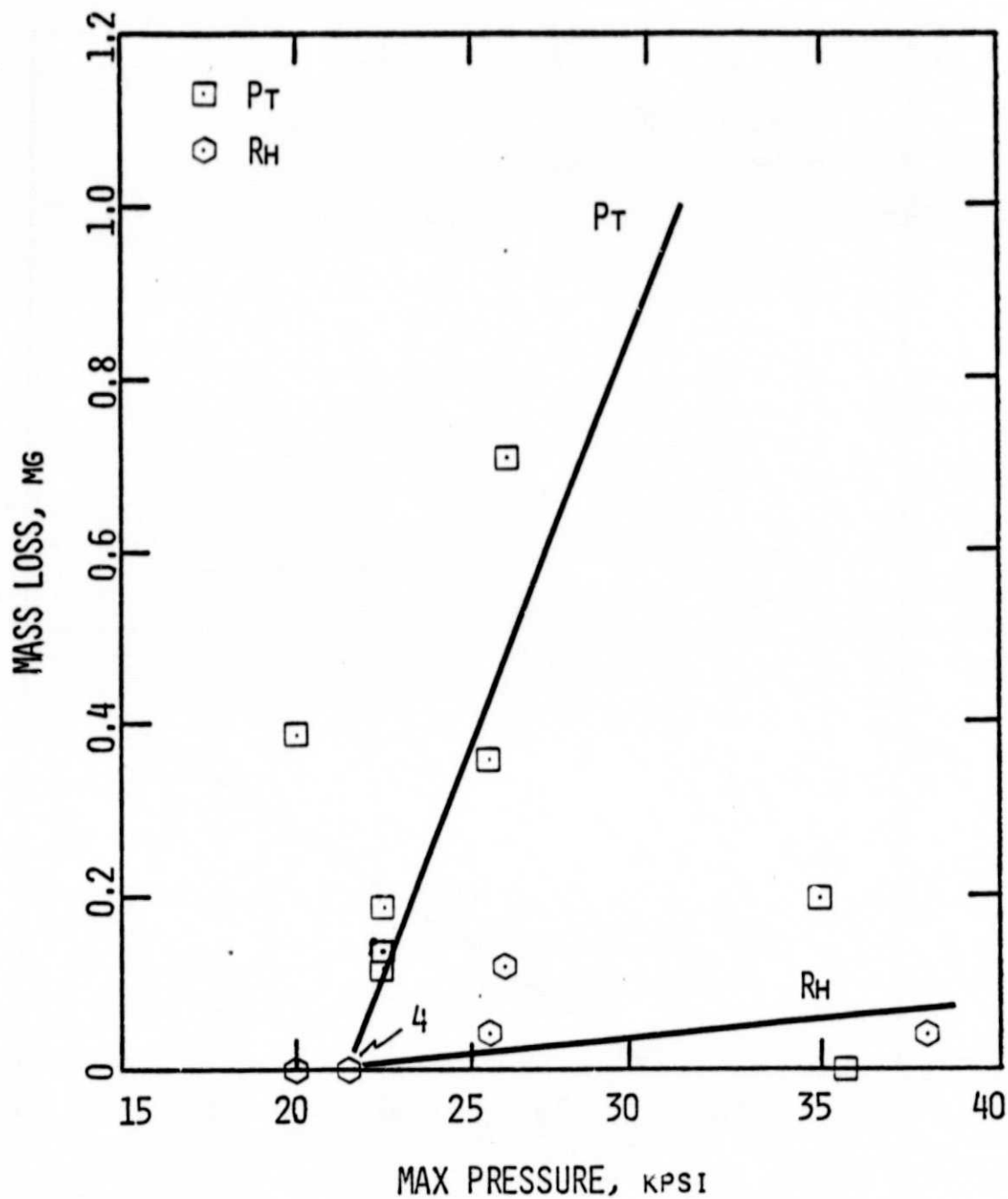

Fig. 7 Pt and Rh mass loss resulting from single exposure to wet H₂. Line is intended to approximate minimum erosion condition.

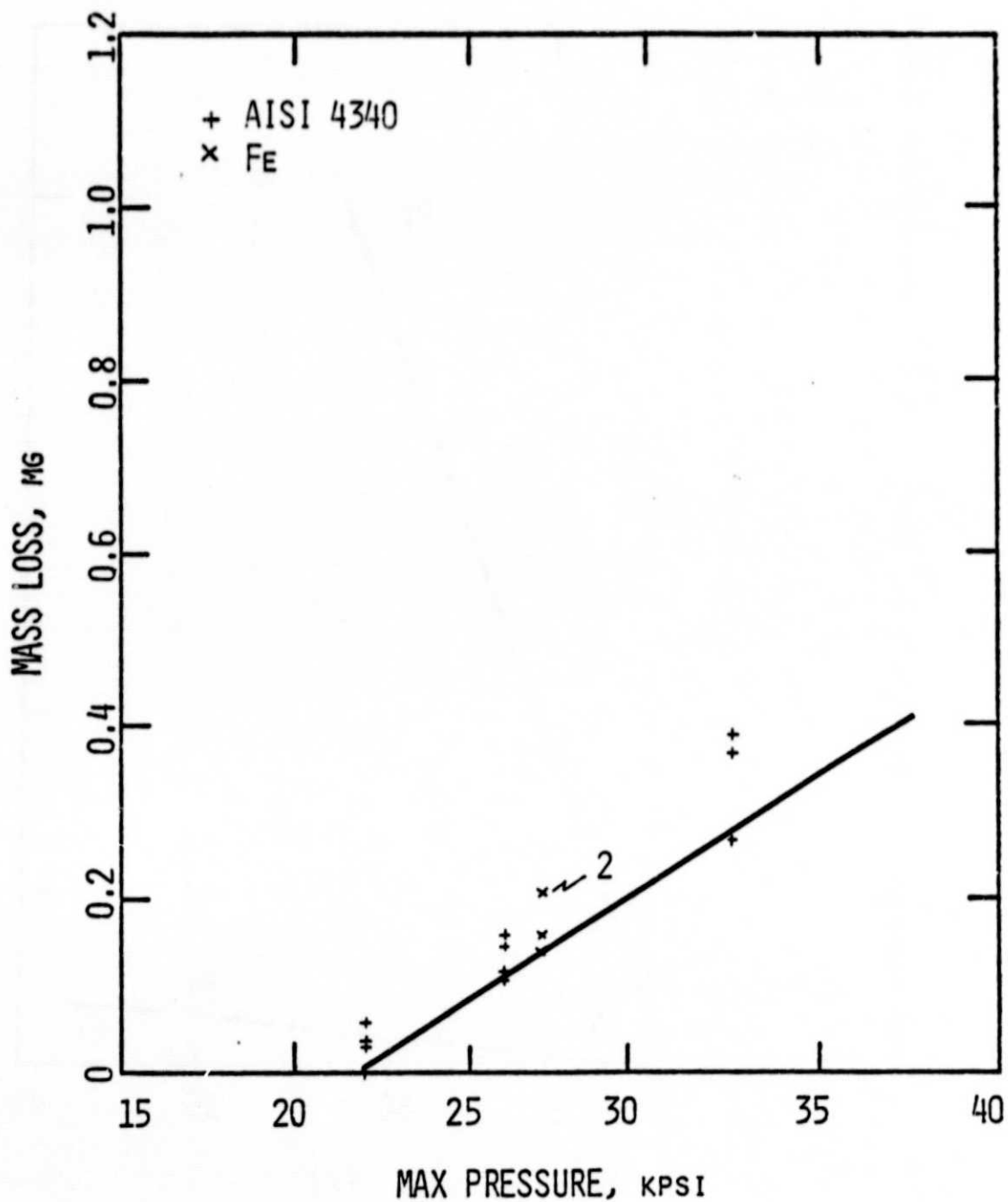

Fig. 8 AISI 4340 and Fe mass loss resulting from single exposure to wet H₂. Line is intended to approximate minimum erosion conditions.