

NASA CASE NO. LAR 14899-1

PRINT FIG. 4

P-16

NOTICE

The invention disclosed in this document resulted from research in aeronautical and space activities performed under programs of the National Aeronautics and Space Administration. The invention is owned by NASA and is, therefore, available for licensing in accordance with the NASA Patent Licensing Regulation (14 Code of Federal Regulations 1245.2).

To encourage commercial utilization of NASA-owned inventions, it is NASA policy to grant licenses to commercial concerns. Although NASA encourages nonexclusive licensing to promote competition and achieve the widest possible utilization, NASA will provide the necessary incentive to the licensee to achieve early practical application of the invention.

Address inquiries and all applications for license for this invention to **NASA Patent Counsel, Langley Research Center, Code 143, Hampton, Virginia 23681-0001.**

Serial No.: 08/297,343
8/24/94

LaRC

(NASA-Case-LAR-14899-1) ADJUSTABLE
BIAS COLUMN END JOINT ASSEMBLY
Patent Application (NASA, Langley
Research Center) 16 p

N95-14111

Unclass

G3/31 0029856

AWARDS ABSTRACT

ADJUSTABLE BIAS COLUMN END JOINT ASSEMBLY

This invention is an improvement to mechanical end joint systems, and more particularly, to a mechanical end joint system useful for the transverse connection of numerous strut elements to a common node to permit the rapid assembly and disassembly of diverse skeletal framework elements.

According to the present invention, an adjustable mechanical end joint system for connecting structural column elements eliminates the possibility of free movement between joint halves during loading or vibration. The end joint has a node joint body having a cylindrical engaging end and a column end body having a cylindrical engaging end. The column end joint body has a compressible preload mechanism and plunger means housed therein. The compressible preload mechanism may be adjusted from the exterior of the column end joint body through a port.

Novel aspects of the present invention include providing a readily accessible external length adjustment to column end joint Belleville washer stacks, without requiring their individual disassembly.

Inventor:	Richard E. Wallsom	Harold G. Bush
Address:	104 Maid Marion Place Williamsburg, VA 23185 [REDACTED]	116 Three Point Court Yorktown, VA 23692 [REDACTED]
Employer:	LESC	NASA LaRC
Initial Evaluator:	Donald R. Rummler	
Serial No.:	08/297,343	
Filed:	8/24/94	

ADJUSTABLE BIAS COLUMN END JOINT ASSEMBLYOrigin of the Invention

5 The invention described herein was made in performance of work under a NASA contract and is subject to provisions of Section 305 of the National Aeronautics and Space Act of 1958, as amended, Public Law 85-568 (72 Stat. 435; 42 USC 2457).

10 Background of the Invention1. Field of the Invention

15 This invention is an improvement to mechanical end joint systems, and more particularly, to a mechanical end joint system useful for the transverse connection of numerous strut elements to a common node to permit the rapid assembly and disassembly of diverse skeletal framework elements.

2. Description of the Related Art

20

 This invention answers an identified problem by overcoming the shortcomings noted on Page 2 (lines 20 - 26), and Page 4 (lines 37 - 51), of U.S. Patent 4,963,052, MECHANICAL END JOINT SYSTEM FOR CONNECTING STRUCTURAL COLUMN ELEMENTS, the specification of which is incorporated herein by reference.

25

 A preload stress presses the components more tightly together to effect a compressive fit, thereby eliminating the possibility of free movement between the joint halves during loading or vibration.

 Dimensions between the latch plunger and sliding latch bolt are critical to the ease and reliability with which these end joint fastenings can be

30

assembled by space-suited astronauts. A target torque range of 35-45 in.lb. is deemed necessary for effective functioning. Component variations as small as 0.01 inch resulted in operating torque variations as great as ± 10 in.lb. in column end joint assemblies due to tolerance accumulations among the various component parts, which in turn affected the initial compression of the Belleville washer stack. No way existed to adjust this torque after assembly, requiring repeated assembly/test/disassembly cycles in the search for a Belleville washer arrangement to meet the 35-45 in.lb. requirement. A typical series of 6 cycles, at the cost of many skilled man-hours operating expensive calibration equipment, was required to assemble an acceptable joint. This process tended to damage threaded joint components.

Summary of the Invention

This invention provides a readily accessible external length adjustment to column end joint Belleville washer stacks, without requiring their individual disassembly. Quicker, more accurate, and more economical assembly of a space-shuttle-borne component can be carried out.

The invention uses a threaded plunger to vary the pre-compression of a Belleville washer stack. The plunger, being accessible following the assembly of the column end joint, may thus be screwed "in" to increase the compression, or "out" to reduce it. These actions in turn, either increase or decrease the torque required to lock the joint assembly to its mating component.

Other objects and advantages of this invention will become apparent hereinafter in the specification and drawings.

Brief Description of the Drawings

Figure 1 is a longitudinal section of the end joint assembly;

Figure 2 is a longitudinal section of the end joint assembly similar to
5 that in FIG. 1, but rotated 90 degrees about the axis thereof;

Figure 3 is an isolated detail of the plunger from FIG. 1, showing the
variable length plunger and Belleville washer stack;

Figure 4 shows the separate joint assemblies preparatory to contact.

Figure 5 is a lateral view of the end joint after both halves have initially
10 mated;

Figure 6 is a lateral view similar to Figure 5, after the operating ring
has been rotated the initial 20 degrees;

Figure 7 is a lateral view of the end joint with both halves fully mated,
after the operating ring has been rotated the final 25 degrees; and

15 Figure 8 is a developed view of the latch operating ring 8.

Description of the Preferred Embodiment

Referring now to FIG. 1, a longitudinal cross-section of the column end
20 joint body 4 is shown. In the illustrated embodiment, an internal latch
mechanism 18 is housed within the column end joint body. FIG. 3 shows the
internal latch mechanism, which comprises the latch bolt 19, preload
Belleville washer stack 32, Belleville washer pin 90, latch plunger 22, latch
retainer 28, and is held together with latch retainer screws 17. Access to the
25 Belleville washer pin 90 by a suitable allen wrench is via the wrench access
port 94.

The internal latch mechanism of FIG. 3 is slidably disposed within the
column end joint body 4, as shown in both FIGS. 1 & 2. A latch spring 30 is
located between latch retainer 28 and latch plug 34, allowing the latch bolt 19

to deflect when a longitudinal force is applied against the inclined face thereof.

Referring now to FIG. 2, another cross-sectional view of column end joint body 4 along line 2-2 of FIG. 1 is shown. Latch pins 20 screw into latch body 22 and serve as an internal race for needle roller bearings 24 and 26.

For the column end joint body 4 to mate with the node joint body 3 as in FIGS. 5, 6 & 7, the transverse force on column end joint body 4 causes sliding latch bolt 19 (FIGS. 1 and 2) to be pushed away from node joint body 3 until the longitudinal axes of the two joint halves become collinear, at which point sliding latch bolt 19 is pushed against conical mating surface 70 by latch spring 30, and the semicircular tongue 78 and groove 80 of the column end joint body 4 mate with semicircular groove 82 and tongue 84 of the node joint body 3, respectively.

To lock the joint and add a preload across the tongue and groove faces, operating ring collar 6 is rotated 45 degrees so that the latch pins 20 are moved toward node joint body 3. Engagement of the halves 3 & 4 of the end joint assembly depresses the latch bolt 18 against the spring 30, resulting in a loose mating position connection between members.

For the complete joint assembly to be taken from the mate position to the locked position, the operating ring 6 is rotated through 45 degrees. The resultant latch pin movement causes a similar movement of latch plunger 22 of FIG. 2, which in turn causes preload Belleville washer stack 32 to compress and exert an equal and opposite force on latch plunger 22 and sliding latch bolt 19. The force imparted to sliding latch bolt 19 causes the column end joint body 4 and node joint body 3 to be pressed more tightly together, effecting a preload compressive fit, thereby eliminating the possibility of free movement between the joint halves during loading or vibration.

After initial mating, the operating ring 6 is rotated through approximately 20 degrees to bring the outer pair of latch bolt bearings 26 to

bear on operating cam 68 of FIG. 6, causing the latch bolt keeper screws 17 to unload. The load generated by the partially compressed Belleville washers 32 is now reacted through the bearings 26 and the cam surfaces 78, and across the conical mating surfaces 70 of the latch bolt 18 and the column
5 node joint 3.

During the final 25 degrees of operating ring 6 rotation (FIG. 7), the Belleville washers 32 are compressed further, and roller bearings 26 finally engage the cam detent 76. The end joint is now fully latched, with preload forces from the Belleville washers 32, applied through the latch mechanism to
10 the mated semicircular faces 70 of the latch 18 and the column end joint body 3.

The mechanism allowing the external adjustment capacity embodied in this invention is clearly seen in FIG. 3, where the Belleville washer pin 90, and wrench access port 94 are evident. The external adjustment capacity
15 offered by this arrangement enables the major gains realized by this invention.

Figure 8 is a developed view of the latch operating ring 8. The force imparted to latch plunger 22 is transferred to the latch operating ring 8 by means of outer needle roller bearings 26, which reached assembly position
20 free space 74 from unlatched bearing point 72 when the semicircular tongues and grooves of FIG. 4 mated.

Referring to FIG. 8, in which a layout of the latch operating ring is depicted, the outer needle roller bearings 26 first move from the open position 72, thence into the assembly position free space 74, up the ramp 75,
25 and over the peak in the latch track until they lock into place in the locked bearing point 76.

Although our invention has been illustrated and described with reference to the preferred embodiment thereof, we wish to have it understood that it is in no way limited to the details of such embodiment, but is capable of

numerous modifications for many mechanisms, and is capable of numerous modifications within the scope of the appended claims.

ADJUSTABLE BIAS COLUMN END JOINT ASSEMBLYAbstract of the Disclosure

- 5 An adjustable mechanical end joint system for connecting structural column elements and eliminating the possibility of free movement between joint halves during loading or vibration has a node joint body having a cylindrical engaging end and a column end body having a cylindrical engaging end. The column end joint body has a compressible preload
- 10 mechanism and plunger means housed therein. The compressible preload mechanism may be adjusted from the exterior of the column end joint body through a port.

FIGURE 1

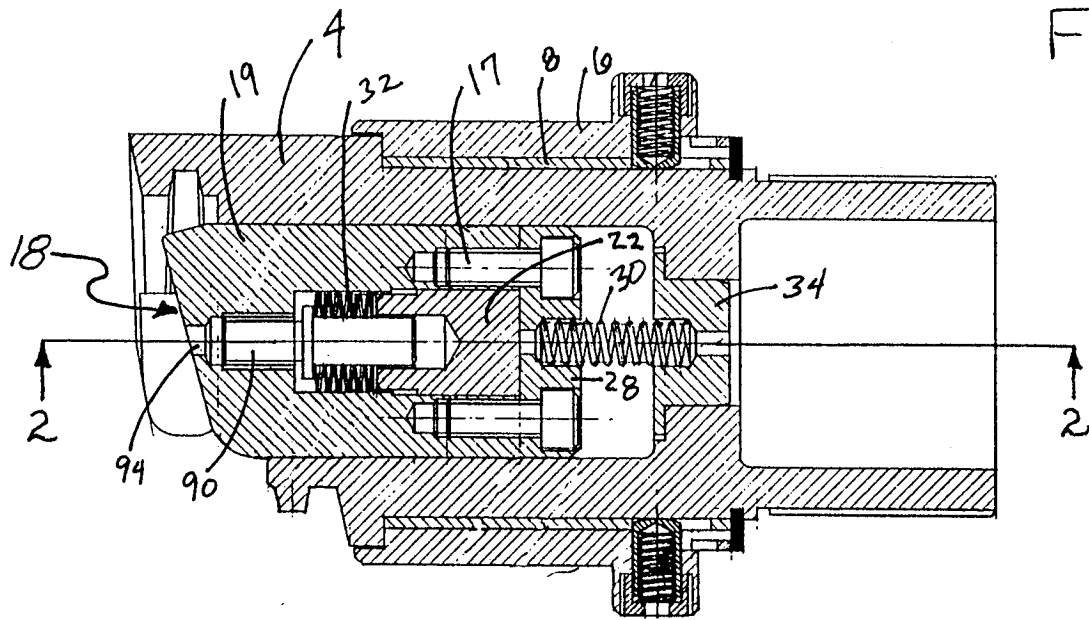

FIGURE 2

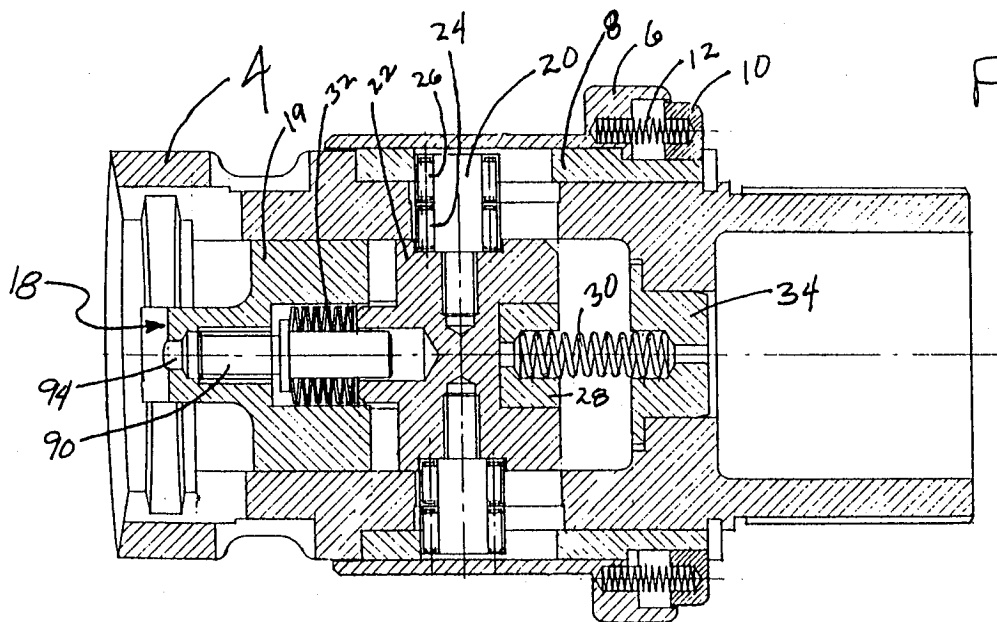

FIGURE 3
INTERNAL LATCH MECHANISM

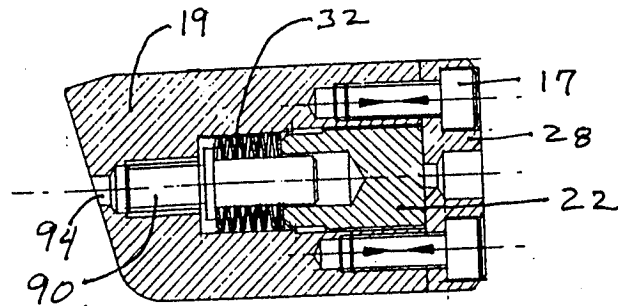

FIGURE 4

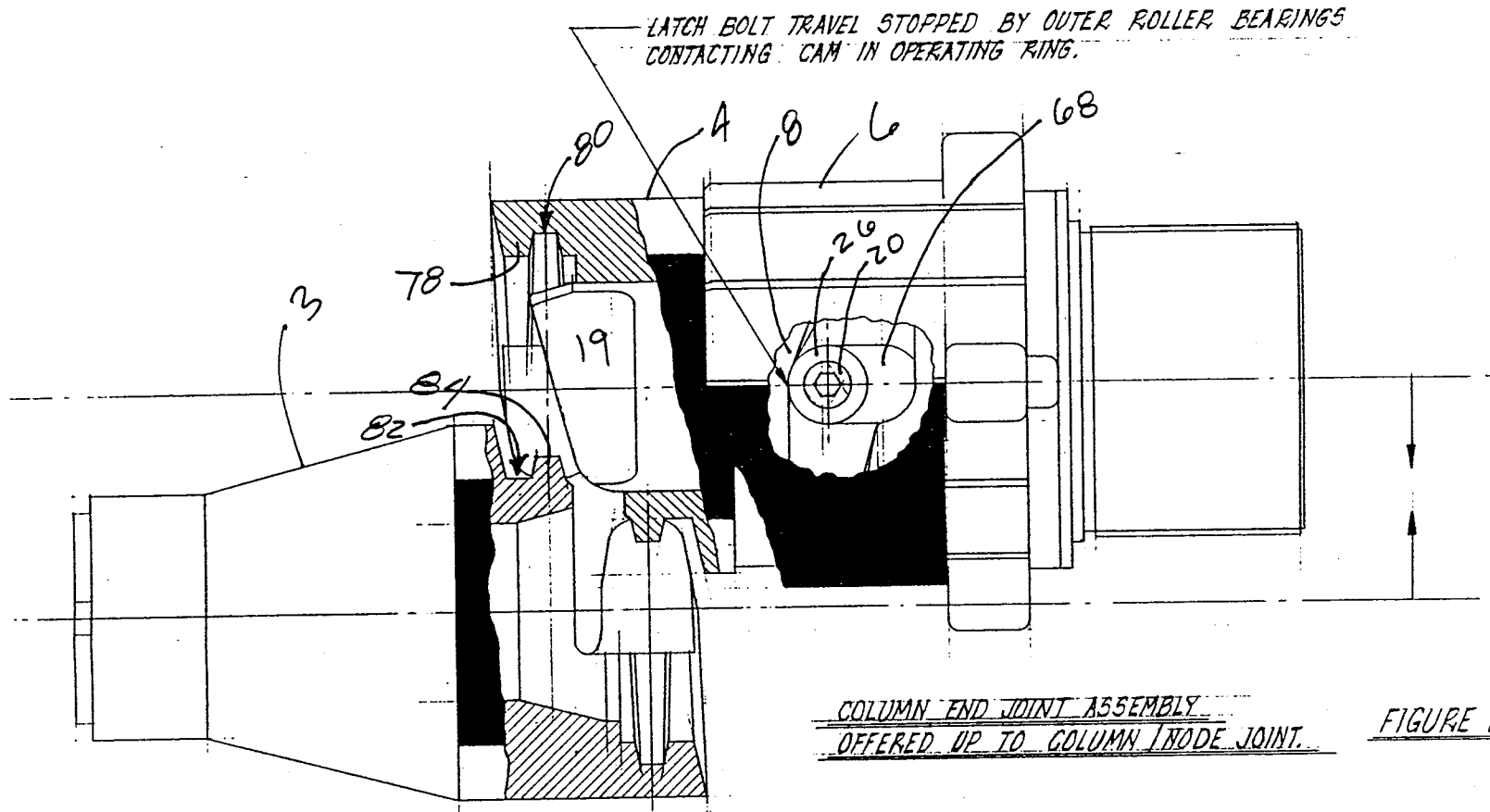

FIGURE 5

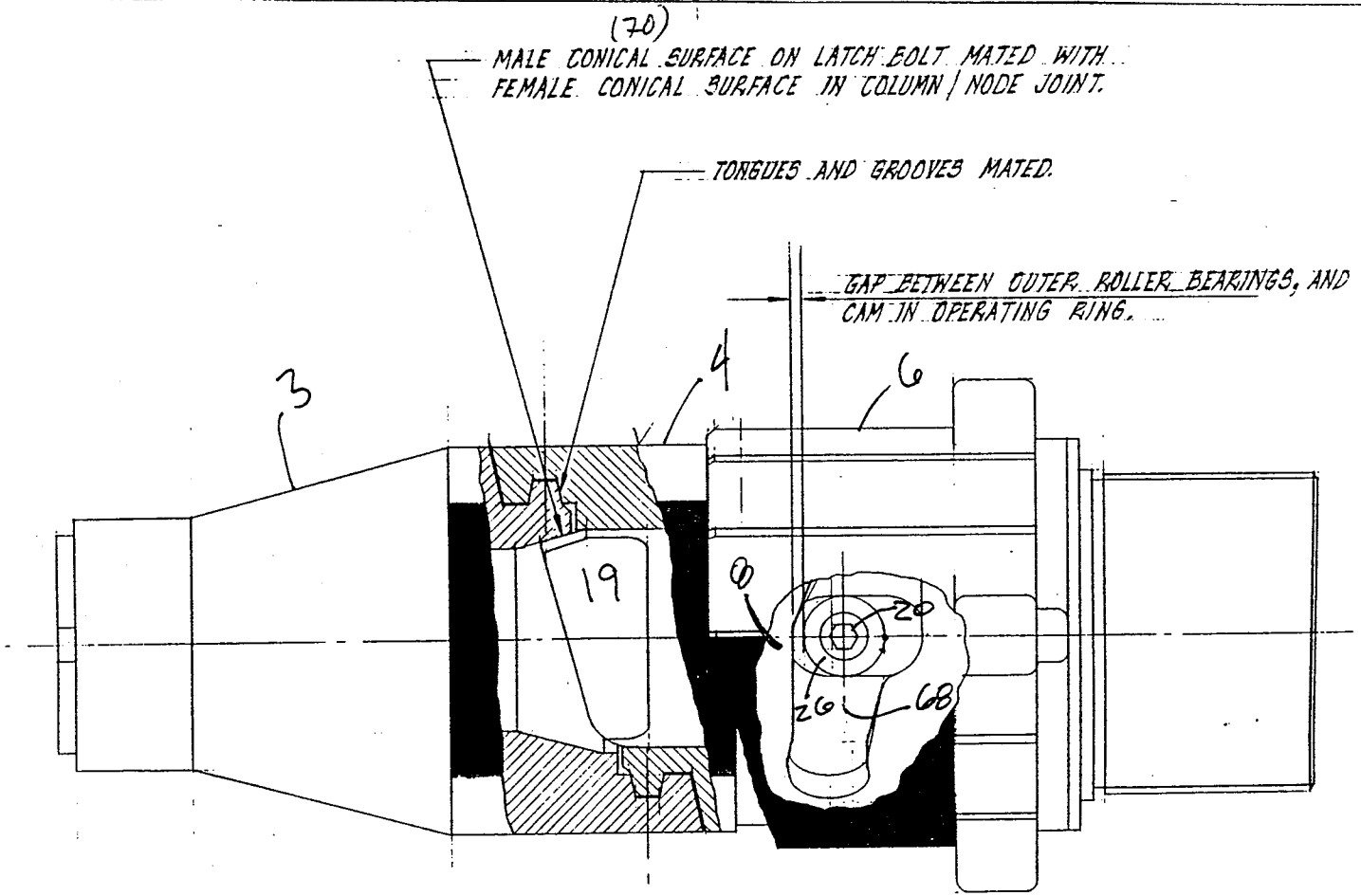

Figure 6

WHEN OPERATING RING IS ROTATED THROUGH 20° , OUTER PAIR OF LATCH BOLT BEARINGS BEAR ON OPERATING RING CAM CAUSING THE LATCH BOLT KEEPER SCREWS TO UNLOAD. THE LOAD GENERATED BY THE PARTIALLY COMPRESSED BELLEVILLE WASHERS IS NOW REACTED THROUGH THE BEARINGS AND THE CAM SURFACES, AND ACROSS THE CONICAL MATING SURFACES OF THE LATCH BOLT, AND THE COLUMN / NODE JOINT.

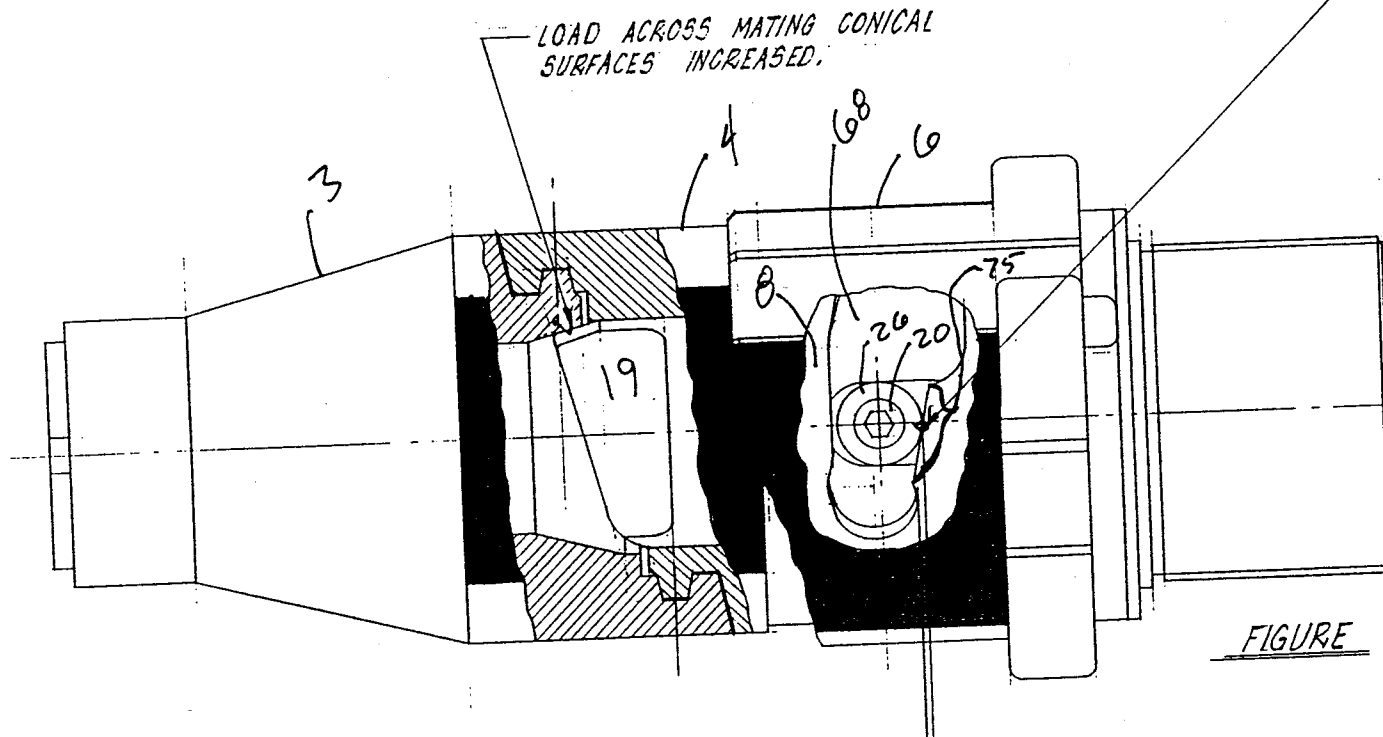
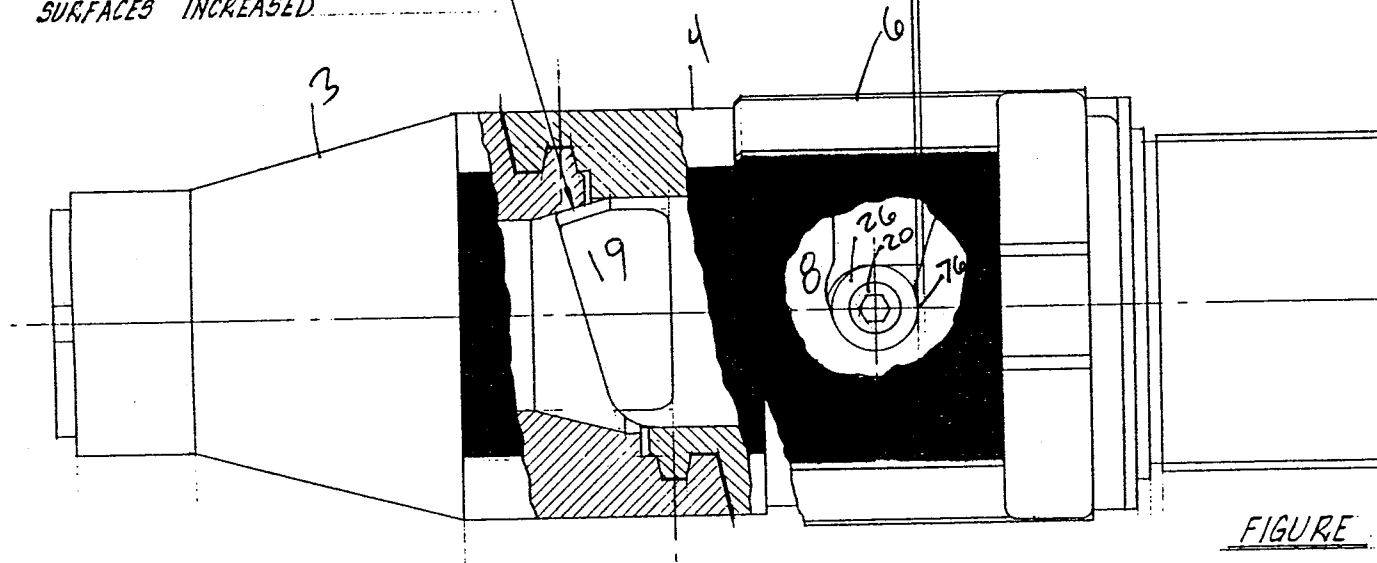

FIGURE 7

FOR THE COMPLETE JOINT ASSEMBLY TO BE TAKEN
FROM THE MATE POSITION TO THE LOCKED POSITION,
OPERATING RING IS ROTATED THROUGH 45°.

DURING THE LAST 25° OF OPERATING RING ROTAT
BELLEVILLE WASHERS ARE COMPRESSED FURTHER, A
ROLLER BEARINGS FINALLY ENGAGE CAM DETENTE.

LOAD ACROSS MATING CONICAL
SURFACES INCREASED



FIGURE

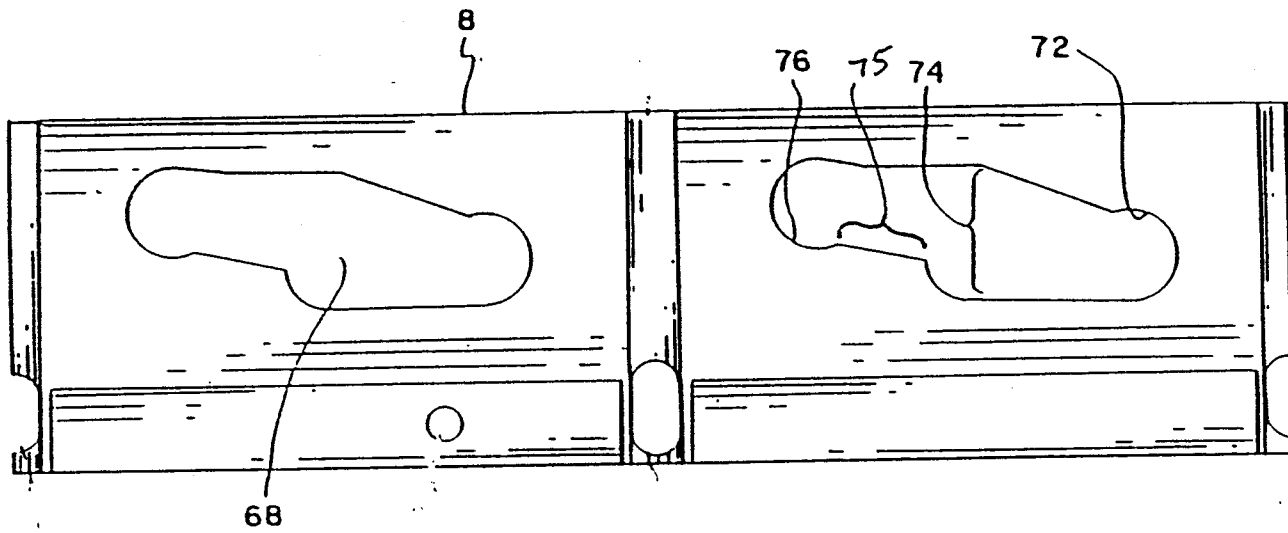

FIG. ~~8~~ 8