



## EU methodology for critical raw materials assessment: Policy needs and proposed solutions for incremental improvements



Gian Andrea Blengini<sup>a,e,\*</sup>, Philip Nuss<sup>a</sup>, Jo Dewulf<sup>a,d</sup>, Viorel Nita<sup>a</sup>, Laura Talens Peirò<sup>a</sup>, Beatriz Vidal-Legaz<sup>a</sup>, Cynthia Latunussa<sup>a</sup>, Lucia Mancini<sup>a</sup>, Darina Blagoeva<sup>b</sup>, David Pennington<sup>a</sup>, Mattia Pellegrini<sup>c</sup>, Alexis Van Maercke<sup>c</sup>, Slavko Solar<sup>c</sup>, Milan Grohol<sup>c</sup>, Constantin Ciupagea<sup>a</sup>

<sup>a</sup> European Commission, DG Joint Research Centre, Ispra, Italy

<sup>b</sup> European Commission, DG Joint Research Centre, Petten, Netherlands

<sup>c</sup> European Commission, DG GROW, Brussels, Belgium

<sup>d</sup> Ghent University, Ghent, Belgium

<sup>e</sup> Politecnico di Torino, Torino, Italy

### ARTICLE INFO

#### Keywords:

Resource criticality assessment  
Supply risk  
Economic importance  
Trade barriers  
Import reliance  
Recycling  
Supply chain

### ABSTRACT

Raw materials form the basis of Europe's economy to ensure jobs and competitiveness, and they are essential for maintaining and improving quality of life. Although all raw materials are important, some of them are of more concern than others, thus the list of critical raw materials (CRMs) for the EU, and the underlying European Commission (EC) criticality assessment methodology, are key instruments in the context of the EU raw materials policy.

For the next update of the CRMs list in 2017, the EC is considering to apply the overall methodology already used in 2011 and 2014, but with some modifications. Keeping the same methodological approach is a deliberate choice in order to prioritise the comparability with the previous two exercises, effectively monitor trends, and maintain the highest possible policy relevance. As the EC's in-house science service, the Directorate General Joint Research Centre (DG JRC) identified aspects of the EU criticality methodology that could be adapted to better address the needs and expectations of the resulting CRMs list to identify and monitor critical raw materials in the EU.

The goal of this paper is to discuss the specific elements of the EC criticality methodology that were adapted by DG JRC, highlight their novelty and/or potential outcomes, and discuss them in the context of criticality assessment methodologies available internationally.

### 1. Introduction

Raw materials form the basis of Europe's economy to ensure jobs and competitiveness, and they are essential for maintaining and improving our quality of life. Securing reliable, sustainable, and undistorted access of raw materials and their circular use in the economy is, therefore, of growing concern within the EU (EC, 2014, 2011; Vidal-Legaz et al., 2016) and globally (Coulomb et al., 2015). Recent years have seen a tremendous increase in the amount of materials extracted and used (Krausmann et al., 2009) together with a significant growth in the number of materials used in single products

(product complexity) (Greenfield and Graedel, 2013). Global economic growth coupled with technological change (e.g., low-carbon energy and transportation systems, modern defence and communication systems) will increase the demand for many raw materials in the future (Blagoeva et al., 2016; Pavel and Tzimas, 2016).

“Criticality” combines a comparatively high economic importance with a comparatively high risk of supply disruption (Buijs et al., 2012). In 2008 the U.S. National Research Council proposed a framework for evaluating material “criticality” based on a metal's supply risk and the impact of a supply restriction (NRC, 2008). Since that time, a number of organizations worldwide have built upon that framework in various

*Abbreviations:* CPA, Statistical classification of products by activity; CRM, Critical Raw Materials; EI, Economic Importance; EOL-RIR, End of Life Recycling Input Rate; GVA, Gross Added Value; HHI, Herfindahl Hirschman Index; IR, Import Reliance; JRC, Joint Research Centre; MSA, Material System Analysis; NACE, Statistical Classification of Economic Activities in the European Community; PPI, Policy Potential Index; RGI, Resource Governance Index; RM, Raw Material; RMI, Raw Materials Initiative; ROW, Rest of the World; SR, Supply Risk; WGI, World Governance Index; WTO, World Trade Organization

\* Corresponding author at: European Commission, DG Joint Research Centre, Ispra, Italy.

E-mail address: [gianandrea.blengini@ec.europa.eu](mailto:gianandrea.blengini@ec.europa.eu) (G.A. Blengini).

<http://dx.doi.org/10.1016/j.resourpol.2017.05.008>

Received 23 January 2017; Received in revised form 9 March 2017; Accepted 17 May 2017

0301-4207/ © 2017 The Authors. Published by Elsevier Ltd. This is an open access article under the CC BY license (<http://creativecommons.org/licenses/by/4.0/>).

ways (BGS, 2012; DOD, 2013; EC, 2014; Graedel et al., 2015; IW Consult, 2011; Morley and Eatherley, 2008; NSTC, 2016; Skirrow et al., 2013).

Even though all raw materials are important (EC, 2010, 2012, 2015), some resources are obviously of more concern than others. The list of CRMs for the EU (EC, 2014, 2011) and the underlying criticality methodology (Chapman et al., 2013; EC, 2010) are therefore key instruments in the context of the EU raw materials policy. Such a list is a precise commitment of the Raw Material Initiative (RMI) (COM, 2008; EC, 2008) and subsequent updates.

The EU criticality methodology was developed between April 2009 and June 2010 with the support of the European Commission's (EC) Ad-Hoc Working Group on Defining Critical Raw Materials (AHWG-CRM) within the RMI in close cooperation with EU Member States (MS) and stakeholders (EC, 2010). The EC criticality methodology has already been used twice; to create a list of 14 CRMs for the EU in 2011 (EC, 2011) and an updated list of 20 CRMs in 2014 (EC, 2014).

Given the intense and active dialogue with multiple stakeholders, the use of best available data reflecting the current situation and recent past (non-speculative and non-forward looking approach), and considering that fully transparent datasets and calculations were made available to a large group of experts, the EC criticality methodology is generally well accepted in the EU, as well as considered reliable and robust. After the two releases of the list and considering several policy documents that make explicit reference to CRMs (EC, 2015, 2012, 2008), it can certainly be stated that the EC criticality methodology is a well consolidated and reliable tool, which represents a cornerstone of the raw materials policy in the EU.

In view of the next update of the CRMs list (every three years according to the RMI), the EC is considering to apply again the same methodology. This choice of continuity is synonymous with giving priority to comparability with the previous two exercises, which is in turn correlated to the need of effectively monitoring trends and maintaining the highest possible policy relevance.

Nevertheless, some targeted and incremental improvements of the existing EU criticality methodology are required, taking into account the most recent methodological developments in the international arena (BGS, 2015; Graedel et al., 2015; NSTC, 2016; Roelich et al., 2014), evolving raw materials markets at international scale, and considering explicit requests from the European industry and changing policy priorities and needs, e.g., on trade (OECD, 2014). A valuable support also came from recent projects funded by the EU under different schemes, which tackled specific aspects of criticality (e.g., CRM\_InnoNet, 2015; ERECON, 2014; EURARE, 2017) and/or contributed to generate European data on flows and stocks of CRMs (BIO by Deloitte, 2015).

As the EC in-house science service, the Directorate General (DG) Joint Research Centre (JRC) provided scientific advice to DG GROWTH in order to assess the current methodology and identify parameters that could be adjusted to better address the needs and expectations toward the methodology of capturing issues of raw materials criticality in the EU. This work was conducted in close consultation with the ad hoc working group on CRMs, who participated in regular discussions with DG GROWTH and other EC services and provided informed expert feedback. The analysis and subsequent revisions started from the assumption that the methodology used for the 2011 and 2014 CRMs lists proved to be reliable and robust and, therefore, the JRC mandate was focused on fine-tuning and/or targeted incremental methodological improvements.

The goal of this paper is to present key new or modified elements of the EU criticality methodology, to highlight their novelties and/or potential outcomes, and to discuss them in the context of criticality assessment methodologies available internationally. A comprehensive presentation of the revised EC methodology is not a goal of the present paper, but will be presented in a future EC publication or communication in view of the third revised list expected in 2017.

## 2. Materials and methods

### 2.1. Current EC criticality methodology

CRMs are both of high economic importance to the EU and vulnerable to supply disruption. Vulnerable to supply disruption means that their supply is associated with a high risk of not being adequate to meet EU industry demand. High economic importance means that the raw material is of fundamental importance to industry sectors that create added value and jobs, which could be lost in case of inadequate supply and if adequate substitutes cannot be found.

Bearing the above concepts in mind, criticality has two dimensions in the EC methodology: (1) Supply Risk (SR) and (2) Economic Importance (EI). A raw material is defined as being critical if both dimensions overcome a given threshold (EC, 2014).

The SR indicator in the EU criticality assessment (EC, 2014, 2011) is based on the concentration of primary supply from countries and their level of governance. Production of secondary raw materials (recycling) and substitution are considered as risk-reducing filters.

The supply risk is calculated with the following equation:

$$SR = HHI_{WGI} \cdot (1 - EoL_{RIR}) \cdot SI \quad (1)$$

In this formula, *SR* stands for supply risk; *HHI* is the Herfindahl Hirschman Index (used as a proxy for country concentration); *WGI* is the scaled World Governance Index (used as a proxy for country governance); *EoL<sub>RIR</sub>* is the End-of-Life Recycling Input Rate; and *SI* is the Substitution Index (EC, 2014).

The importance of a raw material to the economy of the Union is assessed by the indicator “Economic Importance (EI)”. This indicator relates to the potential consequences in the event of an inadequate supply of the raw material. In previous criticality assessments (EC, 2014, 2011), EI was evaluated by accounting for the fraction of each material associated with industrial megasectors at EU level and their gross value added (GVA).

The economic importance is calculated with the following equation:

$$EI = \sum_s (A_s \cdot Q_s) \quad (2)$$

In the above formula *A<sub>s</sub>* is the share of demand of a raw material in a megasector and *Q<sub>s</sub>* is the megasector's Gross Value Added (EC, 2014).

The EC criticality methodology considers both abiotic and biotic raw materials. The 2011 assessment considered 41 non-energy, non-agricultural raw materials (EC, 2011), while the 2014 assessment considered 54 candidate materials (EC, 2014).

As a precise policy mandate, in order to maximise comparability with the 2011 and 2014 CRMs lists, the current methodology is to be retained, except for specific aspects for which there were policy and/or stakeholder needs on the one hand to introduce alterations, or strong scientific reasons for refinement of the methodology on the other. These will be discussed in the next sections.

### 2.2. Policy needs for improvements

The EC criticality methodology, since the publication of the first list of CRMs in 2011, has responded to the needs of governments and industry to better monitor the raw materials situation and inform decision makers about how the security of supply of raw materials can be achieved through diversification of supply, i.e., from different geographical sources but also from primary sources, recycling and substitution and to prioritise needs and actions. For example, at the EU level the list serves as a supporting element in negotiating trade agreements and challenging trade distortion measures, and in programming the research and innovation funding for technological solutions for sustainable production of CRMs or their substitution under the Horizon 2020.

We note that criticality is a screening tool to highlight issues of concern which can subsequently be followed up with more detailed studies and assessments (NSTC, 2016). Again, the results of criticality assessments should be considered a call for attention, not a source of “panic”, or even trigger exaggerated or unbalanced countermeasures (e.g., systematic elimination of CRMs in given categories of products).

The above clarifications hold true even more in the EU policy context, where the EC criticality methodology has a very wide scope in regard to the large number of candidate critical raw materials included (presently around 80) and with its ambitious objective of capturing the economic importance of raw materials using an EU economy-wide approach.

In such a context, it is very unlikely that all aspects that could influence criticality can be included in a screening methodology, while keeping the calculation equations short, simple, and objective.

Also based on an intense discussion with stakeholders, priority was given to the following policy needs, where an improvement or update of the current methodology appeared to be highly desired.

Under the **supply risk** dimension, four policy needs were prioritized: (1) incorporate trade barriers and agreements, (2) adopt a more systematic supply chain approach, (3) take into account import dependency and a more accurate picture of the actual supply to the EU and (4) maintain a prominent role for recycling and improve the quality and representativeness of data for the EU.

*Trade barriers* are increasingly distorting international raw material markets (OECD, 2014). Several cases such as China's export ban on Rare Earth Elements (REEs) showed that impact of trade barriers on the security of supply can be substantial at times. However, current criticality methodologies do not explicitly capture trade distortion risk and this is addressed in the revised EC methodology as described in later sections of this paper.

A systematic *supply chain* approach was considered important, because of possible shifting of criticality along the supply chain (e.g., a supply chain bottleneck present at the smelter stage instead of the mining stage). This issue was already identified in the previous EC study (EC, 2014) and highlighted as a priority by stakeholders, and it is also incorporated into other criticality assessments (Graedel et al., 2015).

Moreover, the current EC methodology (Chapman et al., 2013) bases the supply risk calculation on the global suppliers mix only and a need was expressed during stakeholder discussions to use a more accurate picture of the actual suppliers to the EU, and introduce *import dependency* in the calculations.

Finally, in line with the EU Circular Economy action plan (EC, 2015), a clear mandate was given to the JRC to assess the prominent role of recycling as a risk reducing factor in the supply risk calculation and, moreover, identify data more representative of the EU recycling situation taking into account recently published material stocks and flows data (BIO by Deloitte, 2015).

For the **Economic Importance (EI)** dimension, two policy needs were prioritized: (1) a more detailed and transparent allocation of raw materials uses to their corresponding NACE (Statistical Classification of Economic Activities in the European Community) sectors, and (2) use of a raw materials-specific substitution index in the calculation of EI to allow for a reduction in the potential consequences to the European economy due to inadequate raw materials supply.

The fact that the EC methodology is based on an economy-wide approach creates even higher methodological difficulties, as opposed to assessments where some selected technologies and the related raw materials are targeted. In fact, it is virtually impossible to measure the importance of all applications in which the vast majority of all possible raw materials are used. Moreover, the choice of measuring the EI downstream practically obliges to adopt substantial simplifications. Finally, some stakeholders specifically suggested to introduce substitution in the calculation of EI.

### 2.2.1. Proposed solutions to revise the EU methodology

The following elements summarise the framework and scope of the revision of the EC methodology for criticality assessment:

- Ensure the highest possible level of comparability with the 2011 and 2014 CRM lists;
- Intense and active dialogue with stakeholders from an early-stage in the revision;
- Non-forward looking approach in the assessment based on available data, i.e., criticality is seen as a “snapshot in time” of the current (or past) raw materials situation;
- Use of best quality data reflecting the average of data available for the last 5 years.

A particularly important aspect in the revision of the EC criticality methodology is a clear separation between backward-looking and forward-looking approaches. The revised EC criticality assessment methodology can be considered a snapshot of the current situation, based on the recent past. Potential further analyses of future-orientated options, or forecasts, are not integrated. The sharp distinction between backward-looking and forward-looking approaches can also be presented in terms of the separation between criticality and resilience (Dewulf et al., 2016), where resilience is focused on the future response of the systems in the context of inadequate supply of a given material, the consequences, and options to reduce these.

## 3. Results and discussion

### 3.1. Supply risk

#### 3.1.1. Trade

Export restrictions on raw materials have become more frequent in recent years. They cause higher prices and volatile market conditions and can affect the security of supply.

Although there are many ways to restrict raw material exports, the main restrictive measures are export quotas, export taxes, and licensing requirements. The impact of export restrictions on raw materials is stronger if combined with high supplier country concentration.

Fig. 1 presents the number of export restriction measures for raw materials introduced between 1961 and 2012 and that were still in place in 2012. Export restrictions reported in the OECD Inventory of Restrictions on Trade in Raw Materials for minerals at HS 6 level<sup>1</sup> are presented (OECD, 2014). This consists of the different types of restrictions such as, e.g., export taxes, export quotas, export prohibitions, and license requirements.

While some of these export restrictions have been in place for decades, Fig. 1 highlights that more than 50% of the restrictions that were active in 2012 were introduced only after 2009, and almost 25% were introduced in 2012. Only 12 out of the 72 countries for which the OECD reported export restriction measures did not introduce any measures between 2009 and 2012, while the other 60 countries introduced at least one restriction during this time.

Fig. 2 presents the proportion of global supply subject to export restrictions for a selection of raw materials. This selection includes the 20 critical raw materials for the EU (OECD, 2014), and other materials essential to the EU economy. In this figure, production is considered to be subject to export restrictions if any of the main restrictive measures, i.e., export quotas, export taxes, or licensing requirements, were applied in the producing countries between 2009 and 2012.

One case that received a lot of media attention was the Chinese export restriction on rare earths, tungsten, and molybdenum, for which the EU, USA, and Japan brought a case to the World Trade

<sup>1</sup> HS 6-digit level is the most detailed level used to define products as standard based on the World Customs Organization's harmonised system.

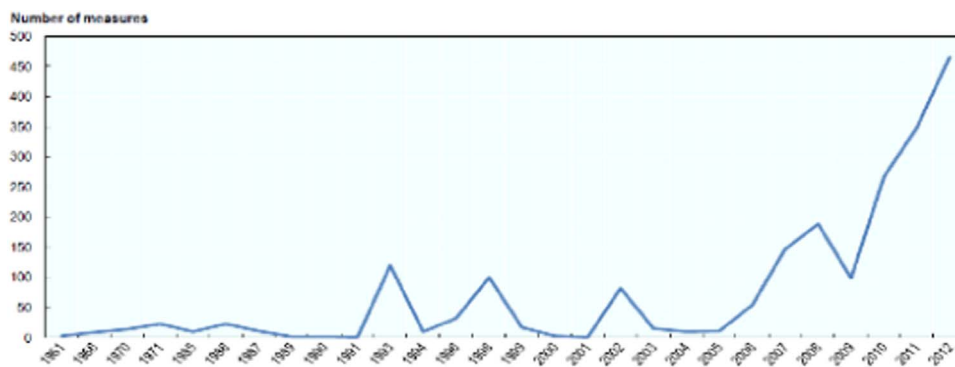

Fig. 1. Introduction year of export restrictions in force in 2012 (OECD, 2014).

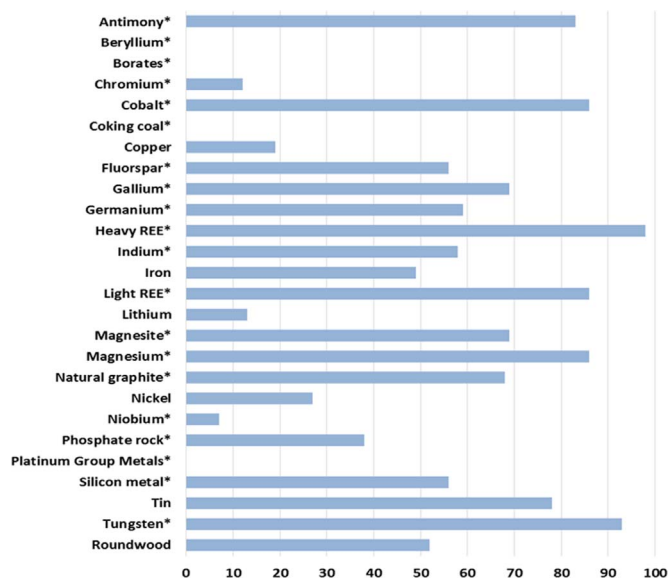

Fig. 2. Proportion of primary global supply potentially subject to export restrictions (2009–2012).

Source: JRC elaboration on OECD data (OECD, 2014)

Organization's (WTO) Dispute Settlement Body in 2012. Following the WTO's ruling, China dropped its export restrictions in January 2015.

Alongside the governance quality in the supplying countries, measured by the World Governance Index (WGI), the restrictions imposed worldwide on exports of certain raw materials (RMs) can increase the supply risk. On the other hand, concluding trade agreements with the supplying countries can result in more secure supply. However, previous criticality assessments (EC, 2014, 2011) did not consider aspects of export restrictions and trade agreements in the evaluation of supply risk. To our knowledge, export restrictions have not yet been integrated into criticality studies published elsewhere (BGS, 2012; DOD, 2013; EC, 2014, 2011; Graedel et al., 2015; IW Consult, 2011; Morley and Eatherley, 2008; NSTC, 2016; Skirrow et al., 2013).

An assessment of the WGI and other country-level indicators suggested that, although WGI is the most robust indicator to capture the level of governance in a country in the context of the criticality assessment, such an index does not capture risks due to export restrictions or the mitigating effects on risk as a result of international trade agreements. Therefore, a specific adjustment for WGI was proposed as an additional trade-related variable. Modifications were tested for some selected raw materials and subsequently discussed with a representative group of experts and stakeholders (AHWG-CRMs) and then adopted.

In the revised methodology, three types of restrictions imposed, i.e., export taxes, physical quotas, and export prohibitions are considered if

these are applied at least once in the reference period 2010–2015.

In respect to export taxes, there are three possible cases:

1) In case a country does not apply export taxes, there is no impact and, hence, no adjustment is needed as the risk is comparable to the EU internal market, for which a 20% reduction of the  $HHI_{WGI}$  is applied.

In case a country applies an export tax, there is an increased supply risk which is either:

2) Mitigated by a bilateral agreement with the EU (if the raw material concerned is covered by the provision on export duty in the agreement) and the supply risk returns to the level as if no export duty was applied;

3) Not mitigated in absence of a trade agreement and the supply risk increases.

The case of export quotas remains a separate element of supply risk, with a specific approach for the calculation of the trade adjustment, as a Free Trade Agreement cannot guarantee their removal. Export prohibitions are considered an extreme case for quotas, i.e., quota is zero.

A worked example with preliminary calculations for tungsten is presented in Table 1.

### 3.1.2. Supply chain approach

The 2014 criticality report (EC, 2014) addressed the comments of the ad-hoc working group of CRMs, which suggested 'examining not only the mining stage but also the smelting and/or refining stages of the supply of raw materials'. In the report, data are provided on the spatial distribution of bauxite mines and aluminium refineries, manganese (mine vs. refinery), nickel (mine vs. refinery), and zinc (mine vs. smelter). The report concluded that assessing the supply risk at different stages of the value chain, i.e., mining and refining, can lead to different results based on changes in the concentration of production.

Based on the above remarks, as a proposed solution, the JRC recommended to systematically adopt a supply chain approach by means of a bottleneck screening in order to assess the likelihood of more than one stage being critical (i.e., mining or refining). In other words, for the calculation of supply risk, the weakest point in the supply chain is considered, i.e., the stage with the highest supply concentration. A similar approach is also applied in other criticality studies (Graedel et al., 2015).

Moreover, this approach also reinforced the conclusions on WGI in respect to alternative indexes, as WGI is applicable to different life-cycle stages (e.g., mining and refining), whereas other indicators (e.g., the Resource Governance Index (RGI) or Policy Potential Index (PPI) may focus only on a single life-cycle stage (e.g., mining) or a specific type of material (e.g., metals and metalloids).

### 3.1.3. Import dependency

In the previous criticality assessments (EC, 2014, 2011), the supply

**Table 1**

Trade barriers / Trade agreements: worked example for Tungsten (2010 data).

Source: JRC elaboration based on EC data (EC, 2014).

HHI <sub>WGI</sub> (scaled) in 2014 EU criticality assessment = 4.5 (EC, 2014)											
Country	% global supply	Share × 100 <sup>2</sup>	WGI	HHI <sub>WGI</sub>	ER	Details	TA/EU	Details	t	HHI <sub>WGI-t</sub>	
Bolivia	2	4.0	6.07	24.3	–	–	–	–	1	24.3	
Vietnam	1	1.0	6.10	6.1	1.1	Tax 20% in 2010	–	–	1.1	6.7	
Austria	1	1.0	2.03	2.0	–	–	0.8	EU28	0.8	1.6	
China	85	7225.0	6.18	44,650.5	1.1	Tax 20% in 2010	–	–	1.1	49,115.5	
Rwanda	1	1.0	5.42	5.4	–	–	–	–	1	5.4	
Portugal	1	1.0	3.15	3.2	–	–	0.8	EU28	0.8	2.5	
Peru	1	1.0	5.37	5.4	–	–	–	–	1	5.4	
Thailand	1	1.0	5.58	5.6	–	–	–	–	1	5.6	
Canada	1	1.0	1.76	1.8	–	–	–	–	1	1.8	
Russian Fed	4	16.0	6.48	103.7	1.1	Tax 10% in 2010	–	–	1.1	114.1	
<b>Total</b>										<b>49,282.9</b>	

**Trade-adjusted HHI<sub>WGI</sub> (scaled) = HHI<sub>WGI-t</sub> / 10,000 = 4.9**

WGI: World Governance Index; HHI<sub>WGI</sub>: Herfindahl-Hirschman Index (scaled by WGI); ER: export restrictions; TA/EU: trade agreement or EU Member State; t: trade adjustment.

risk was calculated based solely on the mix of global supplier countries. However, this does not capture the fact that Europe may depend on a combination of supplier countries different from the global supply mix. In addition, the share of imports to the EU is not fully captured, whereas it is fundamental to make a distinction among RMs that are essentially imported and RMs that are essentially sourced domestically.

In the revised methodology, in order to calculate a more representative measure of the risk for the EU, the global suppliers mix is used in combination with the actual supply to the EU, i.e., the mix of domestic production plus import, which reflects the actual sourcing of the supply to the EU (EU-sourcing). An example for tungsten is presented in Fig. 3.

However, considering data availability and quality for a wide range of materials covered in the EU criticality assessment, a final decision was taken to use both the global supply and actual EU sourcing in combination. In fact, although it is not a true measure of the risk specific to the EU, the risk calculated using global supply is more reliable in terms of data availability and quality (data are reported by various sources, e.g., BGS, 2014; USGS, 2015). Moreover, the mix of global suppliers is sometimes more stable in time, whereas the exporters to the EU might change more rapidly and trade data are known to have significant data quality issues, as well as need to be derived using a combination of different data sources, not always fully compatible. For instance, the EU supply mix can be calculated from trade statistics (EUROSTAT, 2016a, 2016b; United Nations, 2014) and is available partly from other sources (BIO by Deloitte, 2015). Yet, sometimes an exporter country is not the original source for the material shipped to EU28, but just an importer and re-exporter. Therefore, in the revised methodology a balanced approach between

a more representative measure of the risk, but of lower quality (based on EU sourcing), and a more reliable measure, but less representative (based on global supply), is used in the evaluation of supply risk.

The driver to balance the two measures of the supply risk, i.e., the one based on global supply and the one based on the actual sourcing, is the Import Reliance (IR), which is the ratio of net import to apparent consumption.

In the revised methodology, when IR is 100%, i.e. import equals apparent consumption, the risk is the average of the two measures, i.e., 50% based on global supply and 50% based on actual EU sourcing. In the few cases where EU is independent from import, i.e. IR is 0%, the global supply mix is disregarded and the risk is entirely calculated based on the actual sourcing.

### 3.1.4. Recycling

Several reviews about methods to evaluate raw material supply risk are available (Achzet and Helbig, 2013; Ciacci et al., 2015; Dewulf et al., 2016; Erdmann and Graedel, 2011). Beyond the EC criticality methodology, in three out of 15 studies available on criticality, recycling is used in the calculation of supply risk (Erdmann and Graedel, 2011; Graedel et al., 2015; NRC, 2008), but with a less prominent role in comparison to the EC methodology (EC, 2014, 2011) both in terms of visibility and impact on the results.

In the previous criticality assessments (EC, 2014, 2011), recycling is accounted for as ‘the ratio of recycling from old scrap to European supply of raw material’ and referred to as ‘end of life recycling input rate (EOL-RIR)’.

EOL-RIR is used as a mitigation factor that can lower the risk of supply, which depends solely on primary supply (HHI and WGI). The

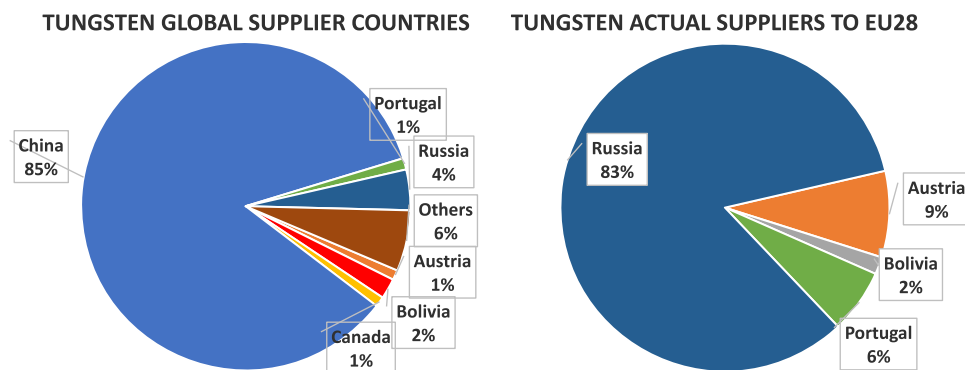

**Fig. 3.** Global Supply of tungsten (left) and actual EU sourcing (right). Source: JRC elaboration based on EC data (EC, 2014)

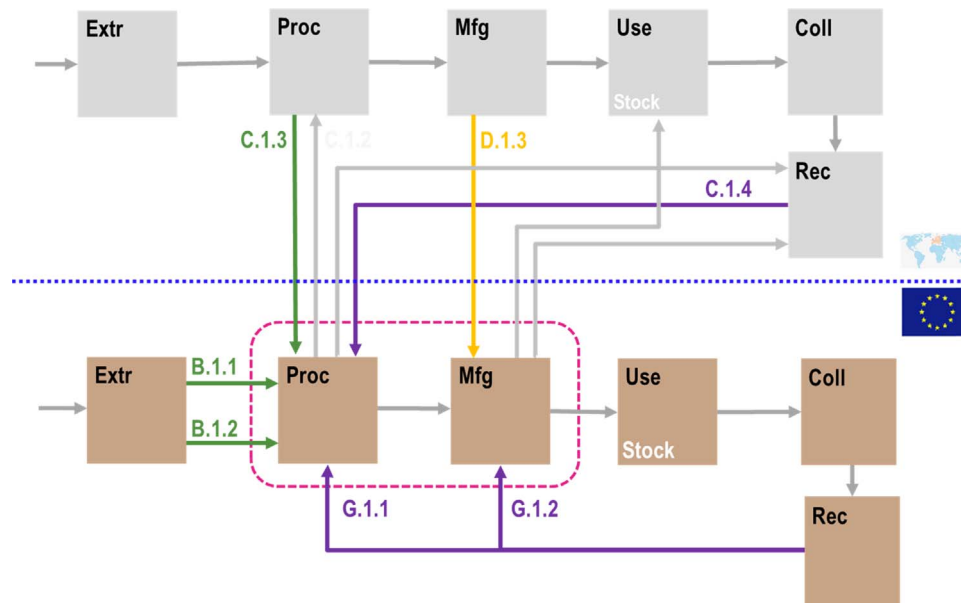

**Fig. 4.** Flows included in the 'EOL-RIR' calculation. Data for the material flows considered are based on the MSA Study (Bio by Deloitte, 2015). (For interpretation of the references to color in this figure, the reader is referred to the web version of this article.)

underlying rationale, already adopted in the previous EC criticality studies, is that the portion of the EU supply of raw materials that is generated via recycling of end-of-life products is assumed to be more secure than other sources of supply (e.g., primary supply from mining/harvesting). Against this background, even though recycling is not riskless in terms of supply, for the purpose of the assessment it is considered that the recycling parameter EOL-RIR identifies a flow of supply with significantly lower risk, which can in turn be subtracted from the overall supply to the EU when calculating the risk.

In the revised methodology, the prominent role of recycling as a risk-reducing filter of supply risk remains unchanged. Efforts are focused on using European data readily available for 28 raw materials assessed in the Raw Material System Analysis (MSA) study commissioned by DG GROW (Bio by Deloitte, 2015) as well as data from the UNEP report 'Recycling Rates of Metals' (Graedel et al., 2011; UNEP, 2011). Guidance on how to update and improve the quality of EOL-RIR is provided via the following options (to be considered in a cascading fashion):

- I. Use the Raw Material System Analysis (MSA) data (Bio by Deloitte, 2015) when available.
- II. Use of data from UNEP's report 'recycling rate of metals' (Graedel et al., 2011; UNEP, 2011), when data from the Raw Material System Analysis (MSA) are not available.
- III. Use of recycling rates from the previous EC criticality assessments (EC, 2014, 2011), or data available from other sources as sectorial reports and expert judgement when MSA and UNEP data are not available.

Fig. 4 illustrates the system boundaries and flows for the calculation of the EOL-RIR when using MSA data. The first part of the figure represents the life cycle stages of a raw material in the rest of the world (ROW), while the life cycle stages of a raw material in Europe are represented by the brown boxes. The system boundary is represented in pink dashes. Flows used for the calculation of the EOL-RIR are represented in green (primary material), yellow (processed material), and purple (secondary material).

EOL-RIR is to be calculated by applying the following formula:

$$EOL - RIR = \frac{G.1.1 + G.1.2}{B.1.1 + B.1.2 + C.1.3 + D.1.3 + C.1.4 + G.1.1 + G.1.2} \quad (3)$$

In summary, the **revised approach for the calculation of supply risk** incorporates new elements for trade, selecting the supply chain bottleneck (i.e., mine or refine production), import dependency and the actual supply mix to the EU (i.e., the actual supply to the EU which equals the mix of domestic production plus imports). In addition, substantial improvements for substitution and recycling as risk-reducing measures were undertaken resulting in the following equation for the calculation of supply risk (SR):

$$SR = \left[ (HHI_{WGI-t})_{GS} \cdot \frac{IR}{2} + (HHI_{WGI-t})_{EUsourcing} \left( 1 - \frac{IR}{2} \right) \right] \cdot (1 - EOL_{RIR}) \cdot SI_{SR} \quad (4)$$

In this formula, SR stands for supply risk; HHI is the Herfindahl Hirschman Index (used as a proxy for country concentration); WGI is the scaled World Governance Index (used as a proxy for country governance); t equals the trade adjustment (of WGI); IR is the Import Reliance;  $EOL_{RIR}$  is the End-of-Life Recycling Input Rate; and  $SI_{SR}$  = Substitution Index related to supply risk.

### 3.2. Economic importance

The importance of a raw material to the economy of the Union is assessed by the indicator Economic Importance (EI). This indicator relates to the potential consequences in the event of an inadequate supply of the raw material.

In previous criticality assessments (EC, 2014, 2011), EI was evaluated by accounting for the fraction of each material associated with industrial megasectors at EU level and their gross value added (GVA). However, megasectors combine several 3- and 4-digit NACE sectors with each other and therefore represent GVA at a high level of aggregation. In order to link raw materials to the corresponding manufacturing sectors at higher levels of sectorial resolution, the JRC examined the classification of product groups, economic activities, and NACE sectors in which raw materials are generally used. The resulting revised approach allows for a more detailed allocation of raw material uses to the corresponding NACE sectors.

The allocation of uses could, e.g., be done using the PRODCOM product groups (EUROSTAT, 2016b) and the 5-/6-digit CPA classes corresponding to each type of use. In the cases in which the identification of a CPA category is not possible, the shares could be allocated directly to the corresponding 4-, 3- or 2-digit NACE sectors.

At NACE 2-digit level, statistical identification of uses turned out to be easier. Allocation of the identified end uses to the NACE 2-digit level sectors is facilitated by the Eurostat's statistical correspondence between CPA, NACE 3-/4-digit and NACE 2-digit.

In the previous criticality assessments (EC, 2014, 2011), substitution was only addressed as a filter to decrease the supply risk (SR). Expert judgment was used to determine the substitution/substitutability indexes. However, substitution can also alter the potential consequences of a supply shortage to the European economy and should therefore also be considered in the economic importance (EI) component.

Substitution of raw materials is addressed in the majority of criticality studies (e.g., Achzet et al., 2011; AEA Technology, 2010; BGS, 2015; Duclos et al., 2010; Graedel et al., 2015; Morley and Eatherley, 2008; Rosenau-Tornow et al., 2009; USDOE, 2011, 2010), in a qualitative or semi-quantitative manner. Expert elicitation is indispensable for such qualitative estimations. A slightly more detailed approach is adopted in the Yale methodology (Graedel et al., 2015; Harper et al., 2015).

In the revised EC methodology, substitution is considered to reduce the potential consequences in the case of a supply disturbance. Substitution is to be incorporated, therefore, into the economic importance (EI) dimension. Nevertheless, given that the availability of substitutes could also mitigate the risk of supply disruptions (SR), as it might decrease demand for a given raw material, it was recommended to also consider substitution in the estimation of SR. In summary, two different substitution factors are used, one in the EI and one in the SR.

Since the scope of the EC assessment focuses on the current situation, only proven substitutes that are readily-available today (snapshot in time) and that could subsequently alter the consequences of a disruption are considered. As a result, only substitution, and not substitutability or potential future substitution, is considered in the revised methodology.

A comprehensive presentation of the revised EC methodology in respect to the underlying calculation of the substitution indexes is not a goal of the present paper, but will be presented in a future EC publication or communication.

In summary, the two main alterations of the refined EI component include: (1) A more detailed and transparent allocation of RM uses to their corresponding NACE sectors, and (2) introduction of a dedicated substitution index  $SI_{EI}$  deemed to be a reduction factor for the EI.

The revised approach to calculate EI and material substitution results in the following calculation procedure:

$$EI = \sum_s (A_s * Q_s) * SI_{EI} \quad (5)$$

where: EI is economic importance;  $A_s$  is the share of end use of a raw material in a NACE Rev. 2 2-digit level sector;  $Q_s$  is the NACE Rev. 2 2-digit level sector's VA;  $SI_{EI}$  is the substitution index (SI) of a RM (to be used in economic importance); and s denotes sector.

#### 4. Conclusion

The EC criticality methodology is a well consolidated and reliable tool, which represents a cornerstone of the raw materials policy in the EU. However, due to changing policy priorities and needs, some targeted and incremental improvements were seen as necessary.

As the European Commission's in-house science service, its Directorate General Joint Research Centre provided scientific advice to DG GROWTH in order to assess the current methodology and identify aspects that could be modified to better address the needs and expectations of the list of CRMs. In view of the next update of the CRMs list foreseen in 2017, the JRC mandate was focused on a fitness check of the current methodology and the introduction of some methodological improvements. This choice of continuity is synonymous with

giving priority to comparability with the previous two exercises, which is in turn correlated to the need of effectively monitor trends and maintain the highest possible policy relevance.

Original contributions in respect to specific elements of criticality assessment were proposed and tested by the JRC, which also highlighted the novelty and potential outcomes.

A comprehensive and detailed presentation of the revised EC methodology is not given in the present paper, as possible fine-tuning might still take place during implementation.

Under the **supply risk** dimension, the main novelties of the revised methodology, in response to the corresponding policy needs include: (1) incorporation of trade barriers and agreements, (2) adoption of a more systematic supply chain bottleneck approach, (3) inclusion of import dependency and a more accurate picture of the actual supply to the EU and (4) confirmation of the prominent role for recycling and a substantial improvement the quality and representativeness of data for the EU.

The two main novelties of the refined **economic importance** component include: (1) A more detailed and transparent allocation of RM uses to their corresponding NACE sectors, and (2) introduction of a dedicated substitution index.

#### Notes

The authors declare no competing financial interests.

#### Acknowledgements

We would like to thank several JRC staff for their help in related analysis and discussions. In particular we thank Cristina Torres de Matos, Claudia Baranzelli, Simone Manfredi, Yildirim Kayam, Claudiu Pavel, Alain Marmier, Patrícia Dias, Evangelos Tzimas, and Fabrice Mathieux.

#### References

- Achzet, B., Helbig, C., 2013. How to evaluate raw material supply risks—an overview. *Resour. Policy* 38, 435–447. <http://dx.doi.org/10.1016/j.resourpol.2013.06.003>.
- Achzet, B., Reller, A., Zepf, V., Rennie, C., Ashfield, M., Simmons, J., 2011. *Materials Critical to the Energy Industry: An Introduction*. University of Augsburg, Augsburg, Germany.
- AEA Technology, 2010. *Review of the Future Resource Risks Faced by Business and an Assessment of Future Viability (Final Report to the Department for Environment, Food and Rural Affairs)*. London.
- BGS, 2015. *Risk List 2015: An Updated Supply Risk Index for Chemical Elements or Element Groups Which are of Economic Value*. British Geological Survey, Nottingham, United Kingdom.
- BGS, 2014. *European Mineral Statistics 2008–2012*. British Geological Service, Keyworth, Nottingham.
- BGS, 2012. *Risk List 2012: An Updated Supply Risk Index for Chemical Elements or Element Groups Which are of Economic Value*. British Geological Survey, Nottingham, United Kingdom.
- BIO by Deloitte, 2015. *Study on data for a raw material system analysis: roadmap and test of the fully operational MSA for raw materials*. Prep. Eur. Comm. DG GROW.
- Blagoeva, D., Aves Dias, P., Marmier, A., Pavel C., 2016. Assessment of potential bottlenecks along the materials supply chain for the future deployment of low-carbon energy and transport technologies in the EU. Wind power, photovoltaic and electric vehicles technologies, time frame: 2015–2030. European Commission, DG Joint Research Centre. (No. EUR 28192 EN, doi: <http://dx.doi.org/10.2790/08169>).
- Buijs, B., Sievers, H., Tercero Espinoza, L., 2012. Limits to the critical raw materials approach. *Proc. Inst. Civ. Eng.* 165, 201–208.
- Chapman, A., Arendorf, J., Castella, T., Tercero Espinoza, L., Klug, S., Wichmann, E., 2013. *Study on Critical Raw Materials at EU Level: Final Report*. Oakdene Hollins, Fraunhofer ISI, Brussels, Belgium.
- Ciacci, L., Reck, B.K., Nassar, N.T., Graedel, T.E., 2015. Lost by design. *Environ. Sci. Technol.* 49, 9443–9451. <http://dx.doi.org/10.1021/es505515z>.
- Coulomb, R., Dietz, S., Godunova, M., Bligaard Nielsen, T., 2015. *Critical Minerals Today and in 2030 (OECD Environment Working Papers)*. Organisation for Economic Co-operation and Development, Paris.
- CRM\_InnoNet, 2015. *Critical Raw Materials Innovation Network [WWW Document]*. URL (<http://www.criticalrawmaterials.eu/>). (Accessed 1 September 2017).
- Dewulf, J., Blengini, G.A., Pennington, D., Nuss, P., Nassar, N.T., 2016. Criticality on the international scene: quo vadis? *Resour. Policy* 50, 169–176. <http://dx.doi.org/10.1016/j.resourpol.2016.09.008>.
- DOD, 2013. *Strategic and Critical Materials: 2013 Report on Stockpile Requirements*.

- United States Department of Defense (DOD), Office of the Under Secretary of Defense for Acquisition, Technology, and Logistics.
- Duclos, S.J.O., Jeffrey, P., Konitzer, Douglas G., 2010. Design in an era of constrained resources. *Mech. Eng.* 132, 36–40.
- EC, 2015. Closing the Loop – An EU Action Plan for the Circular Economy, COM(2015) 614 final. European Commission (EC), Brussels, Belgium.
- EC, 2014. Report on Critical Raw Materials for the EU, Report of the Ad-hoc Working Group on Defining Critical Raw Materials. European Commission (EC), Brussels, Belgium.
- EC, 2012. Making Raw Materials Available for Europe's Future Wellbeing: Proposal for a European Innovation Partnership on Raw Materials. European Commission (EC), Brussels, Belgium.
- EC, 2011. Tackling the Challenges in Commodity Markets and on Raw Materials, COM (2011) 25 final. European Commission, Brussels, Belgium.
- EC, 2010. Critical Raw Materials for the EU, Report of the Ad-hoc Working Group on Defining Critical Raw Materials. European Commission (EC), Brussels, Belgium.
- EC, 2008. The Raw Materials Initiative—Meeting our Critical Needs for Growth and Jobs in Europe, COM(2008)699 final. European Commission (EC), Brussels, Belgium.
- Erdmann, L., Graedel, T.E., 2011. Criticality of non-fuel minerals: a review of major approaches and analyses. *Environ. Sci. Technol.* 45, 7620–7630. <http://dx.doi.org/10.1021/es200563g>.
- ERECON, 2014. European Rare Earths Competency Network [WWW Document]. URL ([https://ec.europa.eu/growth/sectors/raw-materials/specific-interest/erecon\\_en](https://ec.europa.eu/growth/sectors/raw-materials/specific-interest/erecon_en)). (Accessed 1 September 2017).
- EURARE, 2017. Development of a European Rare Earth Element Project [WWW Document]. URL (<http://www.eurare.eu/>). (Accessed 1 September 2017).
- EUROSTAT, 2016a. Comext [WWW Document]. URL (<http://epp.eurostat.ec.europa.eu/newxtweb/>). (Accessed 6 September 2016).
- EUROSTAT, 2016b. Prodcum – Statistics by Product [WWW Document]. URL (<http://ec.europa.eu/eurostat/web/prodcum>) (Accessed 6 September 2016).
- Graedel, T.E., Allwood, J., Birat, J.-P., Buchert, M., Hagelüken, C., Reck, B.K., Sibley, S.F., Sonnemann, G., 2011. What do we know about metal recycling rates? *J. Ind. Ecol.* 15, 355–366. <http://dx.doi.org/10.1111/j.1530-9290.2011.00342.x>.
- Graedel, T.E., Harper, E.M., Nassar, N.T., Nuss, P., Reck, B.K., 2015. Criticality of metals and metalloids. *Proc. Natl. Acad. Sci.* 112, 4257–4262. <http://dx.doi.org/10.1073/pnas.1500415112>.
- Greenfield, A., Graedel, T.E., 2013. The omnivorous diet of modern technology. *Resour. Conserv. Recycl.* 74, 1–7. <http://dx.doi.org/10.1016/j.resconrec.2013.02.010>.
- Harper, E.M., Kavlak, G., Burmeister, L., Eckelman, M.J., Erbis, S., Sebastian Espinoza, V., Nuss, P., Graedel, T.E., 2015. Criticality of the geological zinc, tin, and lead family. *J. Ind. Ecol.* 19, 628–644. <http://dx.doi.org/10.1111/jiec.12213>.
- IW Consult, 2011. Rohstoffsituation Bayern – keine Zukunft ohne Rohstoffe: strategien und Handlungsoptionen (Raw Materials Situation in Bavaria – No Future Without Raw Materials: Strategies and Opportunities of Action). IW Consult GmbH Köln, Cologne, Germany.
- Krausmann, F., Gingrich, S., Eisenmenger, N., Erb, K.-H., Haberl, H., Fischer-Kowalski, M., 2009. Growth in global materials use, GDP and population during the 20th century. *Ecol. Econ.* 68, 2696–2705. <http://dx.doi.org/10.1016/j.ecolecon.2009.05.007>.
- Morley, N., Eatherley, D., 2008. Material Security: Ensuring Resource Availability for the UK Economy. Oakdene Hollins, Ltd., Chester, UK.
- NRC, 2008. Minerals, Critical Minerals, and the U.S. Economy. Committee on Critical Mineral Impacts of the U.S. Economy, Committee on Earth Resources, National Research Council. The National Academies Press, Washington, D.C.
- NSTC, 2016. Assessment of critical minerals: screening methodology and initial application (subcommittee on critical and strategic mineral supply chains of the committee on environment, natural resources, and sustainability of the National Science and Technology Council). Exec. Off. Pres. Natl. Sci. Technol. Council. (NSTC).
- OECD, 2014. Export Restrictions in Raw Materials Trade: Facts, Fallacies and Better Practices. Organisation for Economic Co-operation and Development (OECD).
- Pavel, C., Tzimas, E., 2016. Raw Materials in the European Defence Industry, EUR 27542 EN. European Commission, DG Joint Research Centre, Petten, Netherlands. <http://dx.doi.org/10.2790/0444>.
- Roelich, K., Dawson, D.A., Purnell, P., Knoeri, C., Revell, R., Busch, J., Steinberger, J.K., 2014. Assessing the dynamic material criticality of infrastructure transitions: a case of low carbon electricity. *Appl. Energy* 123, 378–386. <http://dx.doi.org/10.1016/j.apenergy.2014.01.052>.
- Rosenau-Tornow, D., Buchholz, P., Riemann, A., Wagner, M., 2009. Assessing the long-term supply risks for mineral raw materials—a combined evaluation of past and future trends. *Resour. Policy* 34, 161–175. <http://dx.doi.org/10.1016/j.resourpol.2009.07.001>.
- Skirrow, R., Huston, D., Mernagh, T., Thorne, J., Dulfer, H., Senior, A., 2013. Critical Commodities for a High-tech World: Australia's Potential to Supply Global Demand. Geoscience Australia, Canberra.
- UNEP, 2011. Recycling Rates of Metals – A Status Report, A Report of the Working Group on the Global Metal Flows to the International Resource Panel. United Nations Environment Programme (UNEP), Paris.
- United Nations, 2014. UN Comtrade Database [WWW Document]. U. N. Commod. Trade Stat. Database. URL (<http://comtrade.un.org/>). (Accessed 14 May 2014).
- USDOE, 2011. Critical Materials Strategy. U.S. Department of Energy (USDOE).
- USDOE, 2010. Critical Materials Strategy. U.S. Department of Energy.
- USGS, 2015. 2015 Minerals yearbook. Vol 1: Metals and Minerals. U.S. Department of the Interior, U.S. Geological Survey, Reston, Virginia.
- Vidal-Legaz, B., Mancini, L., Blengini, G., Pavel, C., Marmier, A., Blagoeva, D., Latunussa, C., Nuss, P., Dewulf, J., Nita, V., Kayam, Y., Manfredi, S., Magyar, A., Dias, P., Baranzelli, C., Tzimas, E., Pennington, D., 2016. EU Raw Materials Scoreboard 1st ed.. Publications Office of the European Union, Luxembourg.