

## Renewable energy sources offering flexibility through electricity markets

Soares, Tiago; Pinson, Pierre

*Publication date:*  
2017

*Document Version*  
Publisher's PDF, also known as Version of record

[Link back to DTU Orbit](#)

*Citation (APA):*  
Soares, T., & Pinson, P. (2017). Renewable energy sources offering flexibility through electricity markets. Technical University of Denmark, Department of Electrical Engineering.

## DTU Library

Technical Information Center of Denmark

---

### General rights

Copyright and moral rights for the publications made accessible in the public portal are retained by the authors and/or other copyright owners and it is a condition of accessing publications that users recognise and abide by the legal requirements associated with these rights.

- Users may download and print one copy of any publication from the public portal for the purpose of private study or research.
- You may not further distribute the material or use it for any profit-making activity or commercial gain
- You may freely distribute the URL identifying the publication in the public portal

If you believe that this document breaches copyright please contact us providing details, and we will remove access to the work immediately and investigate your claim.

Ph.D. Thesis  
Doctor of Philosophy

**DTU Center for Electric Power and Energy**  
Department of Electrical Engineering

# Renewable energy sources offering flexibility through electricity markets

Tiago Soares

Denmark 2017



# Renewable energy sources offering flexibility through electricity markets

## Author(s):

Tiago Soares

## Supervisor(s):

Prof. Pierre Pinson, Technical University of Denmark

Dr. Hugo Morais, EDF Lab Clamart

## DTU CEE

Center for Electric Power and Energy

Technical University of Denmark

DTU Electrical Engineering

Center for Electric Power and Energy

Elektrovej B325

DK-2800 Kgs. Lyngby

Denmark

[www.cee.elektro.dtu.dk](http://www.cee.elektro.dtu.dk)

Tel: (+45) 45 25 35 00

Fax: (+45) 45 88 61 11

E-mail: [tiasoar@elektro.dtu.dk](mailto:tiasoar@elektro.dtu.dk)

# Summary

---

All over the world, penetration of renewable energy sources in power systems has been increasing, creating new challenges in electricity markets and for operation and management of power systems, since power production from these resources is by nature uncertain and variable. New methods and tools to support optimal decision-making under uncertainty in the electricity markets and power system operation, for both producers and system operators, are developed in this thesis.

The existing market architecture integrates, to some extent, the participation of renewables by allowing these producers to offer in the day-ahead market and to correct for potential energy imbalances in the intraday market and ultimately in the balancing market. However, the design and rules of electricity markets do not support the transition from conventional generation to renewable energy sources as recently sought by many governments. Renewable energy sources are characterized by their uncertain and variable production that limits the current operation and management tools of the power system. Nevertheless, recent developments of renewable energy technologies enable these resources to provide, to some extent, ancillary services. Hence, the opening of the reserve market for renewables participation is crucial for the integration of 100% renewables into the system.

New business models will emerge from these challenges, while renewable energy producers will require appropriate decision-making support tools to jointly offer in both energy and reserve markets. In this context, the main contribution of this thesis is the design and development of optimal offering strategies for the joint participation of renewables in the energy and reserve markets. Two distinct control policies for the splitting of available wind power in energy and reserve are considered. Different methods and optimization tools are developed based on these control policies, considering distinct goals of producers' participation in energy and reserve markets. Nonetheless, these tools allow renewable producers to move forward in the decision-making process of future energy and reserve markets.

Towards a power system based on distributed energy resources, mainly comprising renewable sources, new operation and management of distribution systems needs to be thought of. In fact, the existing passive distribution grid management does not provide the flexibility to deal with uncertainty and intermittency of distributed energy resources.



---

In this context, a major contribution of this work is the design and development of a preventive distribution grid management that allows distribution system operators to contract flexibility (ahead in time) from distributed energy resources to assist in the management and operation of the grid in case of congestion and voltage problems. Such a proposed methodology opens the door to other methods in this timely research problem.

Finally, new costs for this operation and management of the network will arise, requiring new cost allocation methods to split these costs between the energy resources that induce such congestion and voltage problems. To deal with this concern, one can propose new cost allocation methods that divide the costs of operation and management of the distribution network among all network users (generators and consumers) promoting equity, fairness, impartiality and equality. The hybrid methodology combines different costs (fixed, network usage/congestion and losses) covering all the gaps of each conventional cost allocation method.

# Preface

---

This thesis was prepared at the department of Electrical Engineering at the Technical University of Denmark (DTU) in partial fulfillment of the requirements for acquiring a Pd.D. degree.

This thesis aims to develop new methods and tools to support decision-making in the framework of electricity markets and power system operation with large-scale introduction of renewable energy sources. The proposed models focus on various methods for optimal offering of renewable producers in the energy and reserve markets. In addition, the procurement and deployment of flexibility from distributed energy resources to assist the operation and management of distribution systems is addressed. Both directions of research perceive the different perspectives of renewable producers and market/system operator.

The Ph.D. studies were partly supported by the Technical University of Denmark and by the Danish Strategic Research Council through project “5s – Future Electricity Markets” (No. 12-132636/DSF).

The thesis consists of a summary report and six papers, documenting the research conducted during the period between February 2014 and January 2017. Two of these papers appear in conference proceedings and two others are published in international peer-reviewed journals. Finally, the last two papers have been submitted to international peer-reviewed journals and are under review.

Kgs. Lyngby, 31-January-2017

Tiago Soares



# Acknowledgements

---

Coming to the end of an intensive three-year period, I would like to express my deepest gratitude to all those who have contributed along this route in some way to my PhD studies.

First of all, I would like to thank my supervisors Professor Pierre Pinson and Dr. Hugo Morais for their invaluable support, guidance, availability and critical opinions that they have given me to overcome the difficulties that have arisen throughout this work. Their overall perspective on academic research (and beyond it) was really motivational and inspiring.

I would also like to thank Dr. Ricardo Bessa and all members of the Center for Power and Energy Systems (CPES) at the Institute for Systems and Computer Engineering, Technology and Science (INESC TEC) of University of Porto for their hospitality and the excellent research environment they provided during my external stay.

Additionally, I would like to thank all members of the Energy Analytics and Markets (ELMA) group, my fellow PhD students and the administrative staff, for creating an excellent environment during these last three years.

Furthermore, I would like to express my deep gratitude to Ana Andrade, Hugo, Jakob, Jalal, Stefanos, Thanasis, Tiago Pinto and Tiago Sousa who contributed to this work with the hard task of revising this document, always providing valuable comments for the improvement of this manuscript with their different perspectives.

Now to a special group of friends who help me relax from time to time from this PhD work. Thanks to Filipe Fernandes, Gabriel Santos, Hugo Morais, Marco Silva, Tiago Pinto and Tiago Sousa for their support and friendship. A special thanks to Hugo Morais and Tiago Sousa for the innumerable deep discussions and sharing of knowledge in this field of academic research.

Last but not least, a sincerely and deserved thank you goes to my parents, sister, Cristiana and closest friends. Thank you for backing my risk neutral choices and decisions to be away from home in the last three years. Thank you to Cristiana for all your love and support.



# List of publications

---

## Papers included in the thesis

- A. Tiago Soares, Fábio Pereira, Hugo Morais and Zita Vale (2015). “Cost allocation model for distribution networks considering high penetration of distributed energy resources”, *Electric Power Systems Research* (available online), DOI: [dx.doi.org/10.1016/j.epsr.2015.03.008](https://doi.org/10.1016/j.epsr.2015.03.008).
- B. Tiago Soares, Gabriel Santos, Tiago Pinto, Hugo Morais, Pierre Pinson and Zita Vale (2015). “Analysis of strategic wind power participation in energy market using MASCEM simulator” in proceeding of *18<sup>th</sup> International Conference on Intelligent System Application to Power Systems*, Porto, Portugal.
- C. Tiago Soares, Pierre Pinson, Tue V. Jensen and Hugo Morais (2016). “Optimal offering strategies for wind power in energy and primary reserve markets”, *IEEE Transactions on Sustainable Energy* (available online), DOI: [dx.doi.org/10.1109/TSTE.2016.2516767](https://doi.org/10.1109/TSTE.2016.2516767).
- D. Tiago Soares, Pierre Pinson and Hugo Morais (2016). “Wind offering in energy and reserve markets” in *Journal of Physics: Conference Series* (available online), presented in *proceedings of WindEurope Summit*, Hamburg, Germany, DOI: [dx.doi.org/10.1088/1742-6596/749/1/012021](https://doi.org/10.1088/1742-6596/749/1/012021).
- E. Tiago Soares, Ricardo Bessa, Pierre Pinson and Hugo Morais. “Active distribution grid management based on robust AC optimal power flow”, *IEEE Transactions on Smart Grid* (under review).
- F. Tiago Soares, Tue V. Jensen, Nicolò Mazzi, Pierre Pinson and Hugo Morais. “Optimal offering and control policies for wind power in energy and reserve markets”, *Wind Energy* (under review).

## Other works not included in the thesis

- G. Tiago Soares, Reid Simon, Qi Wang and Caroline Persson (2014), “Integration of wind generation in electricity markets under uncertainties”, in proceedings of *Grøn Dyst – Student conference on sustainability, the environment and climate technology*, Technical University of Denmark, Kgs. Lyngby, Denmark.

- 
- H. Tiago Soares, Hugo Morais and Pierre Pinson (2014). “Analysis of the impact of wind power participating in both energy and ancillary services markets – the Danish case”, in proceedings of *13<sup>th</sup> International Workshop on Large-Scale Integration of Wind Power into Power Systems*, Berlin, Germany.
  - I. Tiago Sousa, Tiago Soares, Hugo Morais, Rui Castro and Zita Vale (2016). “Simulated annealing to handle energy and ancillary services joint management considering electric vehicles”, *Electric Power Systems Research* (available online), DOI: <http://dx.doi.org/10.1016/j.epsr.2016.03.031>.

# List of acronyms

---

<b>Notation</b>	<b>Description</b>
AC	– Alternating Current
ATC	– Available Transfer Capacity
DER	– Distributed Energy Resources
DSO	– Distribution System Operator
ESS	– Energy Storage Systems
EV	– Electric Vehicles
LDR	– Linear decision rules
LMP	– Locational Marginal Price
OPF	– Optimal Power Flow
PLDR	– Piecewise linear decision rules
PV	– Photovoltaic units
RES	– Renewable Energy Sources
RTD	– Real-Time Dispatch
RTUC	– Real-Time Unit Commitment
SCED	– Security Constrained Economic Dispatch
SCUC	– Security Constrained Unit Commitment
STUC	– Short-Term Unit Commitment
TSO	– Transmission System Operator
WPP	– Wind Power Producers





# Nomenclature

---

The main notation (symbols, variables and parameters) used throughout the thesis is stated here for quick reference. Other symbols are defined as required in the text.

## A. Indices and sets

$\Omega$	Set of scenarios
$\omega$	Scenarios index
$dg$	Distributed generation index
$i,j$	Number of lines for PLDR approach
$l$	Loads index
$st$	Energy storage system index
$v2g$	Vehicle-to-grid index
$W$	Uncertainty set

## B. Parameters

$\varepsilon$	Coefficient to control the share deviation between day-ahead and balancing stages
$\lambda$	Expected market price
$\pi$	Probability
$DF$	Distribution factor for fixed costs
$DN$	Distribution factor for costs of network usage
$Flow$	Power flow in branch $i,j$
$P^{Max}$	Maximum total power offer
$P^{Min}$	Minimum total power offer

---

$Q_w^*$	Eventually observed wind power in scenario $w$
$X$	Payment factor for energy resources

### C. Superscripts

+	Positive imbalance (for unit being long – surplus)
–	Negative imbalance (for unit being short – deficit)
*	Balancing stage
$bpt$	Unit reserve penalty cost for the wind power producer
$c$	Contracted/offered in day-ahead stage
$Ch$	Charge ability of storage $st$
$Dch$	Discharge ability of storage $st$
$Fixed$	Fixed cost allocation
$NetUse$	Cost allocation of network usage
$pt$	Penalty for reserve imbalance

### D. Variables

$\alpha$	Control share of proportional control strategy
$\Delta E$	Energy imbalance
$\Delta R$	Reserve imbalance
$E$	Expected energy
$Q$	Total amount offer / optimal offer
$R$	Expected power reserve

### E. Commonly used symbols in optimization models

$\alpha, \mu$	Vectors of Lagrange multipliers associated with equality and inequality constraints
---------------	---

---

$\beta$	Worst-case recourse cost
$\delta$	Random variable for linear decision rules
$\lambda$	Vector of prices and penalties
$C$	Vector of cost coefficients
$f, g$	Vectors defining the right-hand-side of equality and inequality constraints
$F, G$	Matrices defining the left-hand-side of equality and inequality constraints
$H, T$	Matrices defining the left-hand-side of recourse constraints
$K$	Vector with the slope of affine function
$\mathcal{L}$	Lagrangian function
$L_{i,j}$	Lifting operator for piecewise linear decision rules in line $i,j$
$m$	Vector defining the right-hand-side of constraints bounding the uncertain parameter for LDR
$M$	Matrix defining the left-hand-side of constraints bounding the uncertain parameter for LDR
$q$	Vector of recourse cost coefficients
$r_i$	Identification number of line $i$ for piecewise linear decision rules
$V$	Square matrix relating breakpoints for piecewise linear decision rules
$x$	Vector of decision variables
$y$	Vector of recourse decision variables
$z_j^i$	Breakpoints for piecewise linear decision rules



# Contents

---

<b>SUMMARY</b> .....	<b>I</b>
<b>PREFACE</b> .....	<b>III</b>
<b>ACKNOWLEDGEMENTS</b> .....	<b>V</b>
<b>LIST OF PUBLICATIONS</b> .....	<b>VII</b>
<b>LIST OF ACRONYMS</b> .....	<b>IX</b>
<b>NOMENCLATURE</b> .....	<b>XI</b>
<b>CONTENTS</b> .....	<b>XV</b>
<b>PART I SUMMARY REPORT</b> .....	<b>1</b>
<b>1 INTRODUCTION</b> .....	<b>3</b>
<b>1.1 Context and motivation</b> .....	<b>3</b>
<b>1.2 Thesis objectives and contributions</b> .....	<b>5</b>
<b>1.3 Thesis structure</b> .....	<b>8</b>
<b>2 RENEWABLE ENERGY INTEGRATION IN ELECTRICITY MARKETS</b> .....	<b>11</b>
<b>2.1 Electricity market designs</b> .....	<b>11</b>
2.1.1 Day-ahead market .....	13
2.1.2 Intraday market .....	13
2.1.3 Real-time and balancing market.....	14
2.1.4 Ancillary services / reserve market.....	14

---

<b>2.2</b>	<b>Renewables in electricity markets.....</b>	<b>15</b>
2.2.1	Current support schemes .....	15
2.2.2	Impact on electricity markets .....	15
2.2.3	Renewables producers trading in the electricity market.....	16
<b>2.3</b>	<b>Challenges for current and future market designs .....</b>	<b>17</b>
2.3.1	Capacity markets.....	17
2.3.2	Electricity market design regarding uncertainty.....	17
2.3.3	Renewables in reserve markets .....	18
2.3.4	Towards a power system based on DER .....	19
<b>3</b>	<b>OPTIMIZATION UNDER UNCERTAINTY .....</b>	<b>23</b>
<b>3.1</b>	<b>Basics of optimization .....</b>	<b>24</b>
3.1.1	Linear programming .....	24
3.1.2	Duality theory .....	25
3.1.3	Nonlinear programming.....	26
<b>3.2</b>	<b>McCormick envelopes .....</b>	<b>27</b>
<b>3.3</b>	<b>Stochastic programming .....</b>	<b>28</b>
3.3.1	Basic concept .....	29
3.3.2	Two-stage stochastic programming.....	29
<b>3.4</b>	<b>Robust optimization.....</b>	<b>30</b>
3.4.1	Uncertainty set definition .....	31
3.4.2	Adaptive robust optimization .....	32
<b>3.5</b>	<b>Optimization using linear decision rules.....</b>	<b>34</b>
3.5.1	Linear decision rules .....	34
3.5.2	Piecewise linear decision rules .....	36
<b>4</b>	<b>RENEWABLE ENERGY TRADING IN ENERGY AND RESERVE MARKETS .....</b>	<b>41</b>
<b>4.1</b>	<b>Energy and reserve offering market model .....</b>	<b>42</b>
4.1.1	Price-taker behavior.....	43
4.1.2	Expected mean prices .....	43
4.1.3	Probabilistic wind power forecast .....	43
4.1.4	Reserve balancing mechanism.....	43

---

4.1.5	Taking advantage of better forecast information.....	44
<b>4.2</b>	<b>Energy-only – analytical optimization.....</b>	<b>45</b>
<b>4.3</b>	<b>Control policies for wind power .....</b>	<b>46</b>
<b>4.4</b>	<b>General formulation of market revenues .....</b>	<b>47</b>
<b>4.5</b>	<b>Analytical approach.....</b>	<b>49</b>
4.5.1	Optimal offering under constant control.....	49
4.5.2	Optimal offering under proportional control .....	50
4.5.3	Optimal energy and reserve bids.....	50
<b>4.6</b>	<b>Optimization techniques .....</b>	<b>51</b>
4.6.1	Flexible stochastic approach.....	51
4.6.2	Fixed stochastic approach.....	52
4.6.3	Stochastic approach under McCormick relaxation .....	53
4.6.4	Piecewise linear decision rules with axial segmentation.....	53
4.6.5	Optimal energy and reserve bids.....	54
<b>4.7</b>	<b>Conclusions .....</b>	<b>57</b>
<b>5</b>	<b>RENEWABLES FLEXIBILITY FROM THE MARKET AND SYSTEM OPERATION PERSPECTIVE.....</b>	<b>59</b>
<b>5.1</b>	<b>Electricity market equilibrium .....</b>	<b>60</b>
5.1.1	Multi-agent system .....	60
5.1.2	Wind offering assessment .....	61
<b>5.2</b>	<b>Preventive distribution grid management .....</b>	<b>62</b>
5.2.1	Framework for preventive distribution grid management.....	63
5.2.2	Assessment of preventive distribution grid management.....	66
<b>5.3</b>	<b>Grid cost allocation.....</b>	<b>69</b>
5.3.1	Framework for cost allocation of distribution grids .....	70
5.3.2	Assessment of cost allocation method .....	74
<b>6</b>	<b>CONCLUSIONS AND FUTURE RESEARCH .....</b>	<b>77</b>
<b>6.1</b>	<b>Overview of contribution .....</b>	<b>77</b>
<b>6.2</b>	<b>Future research .....</b>	<b>81</b>



---

<b>BIBLIOGRAPHY.....</b>	<b>83</b>
<b>PART II PAPERS.....</b>	<b>89</b>
<b>A PAPER A.....</b>	<b>91</b>
<b>B PAPER B.....</b>	<b>105</b>
<b>C PAPER C.....</b>	<b>113</b>
<b>D PAPER D.....</b>	<b>125</b>
<b>E PAPER E.....</b>	<b>135</b>
<b>F PAPER F.....</b>	<b>149</b>

Part I

# Summary Report



# Introduction

---

## 1.1 Context and motivation

Over the last few decades, climate change has been on the agenda of governments in most industrialized countries to reduce greenhouse gas emissions. Within this context, **Renewable Energy Sources (RES) have been playing a key role in the development of power systems** as a prominent clean energy source contributing to the mitigation of greenhouse gas emissions from conventional power plants. In particular, some countries such as Denmark have established as ambitious targets the complete independence from fossil fuels by 2050 [1]. The resulting deployment of RES has been supported by remuneration schemes that dampen financial risk induced by market participation. The rapid and massive deployment of renewable power generation helped lower the per-unit-cost of such technologies (e.g., wind and photovoltaic (PV)). Renewable power producers are now not only able, but also required to participate in the electricity markets under conditions similar to those for conventional power producers [2].

Nonetheless, electricity market designs are still operating under the conventional characteristics of power systems. In fact, rules and grid codes that support electricity market designs have been defined based on the operation and management of power systems under conventional power plants. These types of power plants are fully *dispatchable*, i.e., the power plant operator has full control of the power production, as well as full knowledge of the ramp characteristics of the power plant. Traditional operation and management methods were sufficient to control the power system with proper levels of reliability and security. Furthermore, market designs were modeled based on the technical and economic characteristics of these energy resources. In the meantime, conventional power generation has been replaced by renewable generation, and therefore **current market designs have been adjusted to the technical and economic characteristics of RES**. Still, current market designs are far away from taking full advantage from RES participation.

One of the main impacts of RES on electricity markets is the influence on the electricity prices. **RES reduces the average electricity market price, since its marginal cost is near zero, or even negative if it is under incentive remuneration schemes** [3]. That

is, renewables are dispatched before the conventional power producers, influencing the market price. However, the uncertainty of their production may increase the price volatility in the system, especially in cases of low flexibility. Reserve prices may significantly increase to ensure sufficient reliability, while energy prices can become negative to avoid shutting down conventional power plants, which is very expensive. For instance, during peak periods of PV production, where RES is dispatching all its power due to its production incentive schemes, and conventional producers must maintain their minimum production due to technical constraints, energy prices become negative. On the other hand, periods with low RES power production are characterized by higher prices and lower production/consumption ratio.

From the technical point of view, RES are *non-dispatchable* resources (aside from hydro and biomass power plants). More precisely, the output power of renewable power plants is stochastic, and thus cannot be fully controlled by the operator. These resources **introduce uncertainty and intermittency into the power system**, and therefore proper methods to deal with this uncertainty, as well as proper procurement levels of reserve and flexibility of all energy resources should be considered [4]. Therefore, a market perspective under the 100% RES target in the power system **means higher procurement of reserve to support such levels of uncertainty**, as well as RES supporting part of ancillary services.

**Current developments of RES technologies enable them to support limited reserve/flexibility levels**, which keeps the power system running under proper levels of security and reliability [5]. Such technical capability opens the door to new market designs, where RES can compete in energy and reserve markets. These new market designs must consider the stochastic production of RES, i.e., the possibility of RES failing to provide the energy and reserve. For example, new market designs may include penalties when RES do not provide committed energy and reserve levels. Additionally, **new business models and remuneration mechanisms** for the optimal integration of **RES in the energy and reserve markets** should be taken into account. In particular, RES producers may seek new strategies and control policies to offer their availability in the energy and reserve markets.

In addition to the aforementioned challenges, **technical challenges may arise in the operation and management of the power system**, namely in distribution grids with high penetration of Distributed Energy Resources (DER) (mainly composed of RES). More specifically, it is expected that future distribution systems will face voltage and congestion problems due to the continuous increase of electricity consumption (e.g., electric vehicles) as well as small intermittent production at consumption points (e.g., PV panels). For instance, the high production of PV occurs in periods of low consumption, which can induce overvoltage problems in the distribution network. Thus, adequate support tools for **preventive operation and management of distribution grids must be taken into account**. The most likely approach would be to have

Distribution System Operators (DSO) take advantage of the power flexibility of DER to solve potential line congestion and voltage problems, as well as deal with the uncertain and variable power production in the system [6]. More precisely, the potential flexibility of DER can be used by DSO to manage technical problems. The DSO will contract such flexibility from different DER, depending on various technical conditions (such as location, upward and downward flexibility, operating cost, among others). Thus, a new market design can emerge to allow DSO to contract flexibility ahead of delivery requirements.

These changes in the power system have resulted in a new paradigm characterized by a complex, unpredictable and decentralized operation and management [7], [8]. In this context, **traditional cost allocation methods are no longer valid, since DER can create different directions of power flow** in distribution grids, as some DER may behave as producers or consumers (such as Energy Storage Systems (ESS) and Electric Vehicles (EV) with vehicle-to-grid ability). In fact, the costs for using the network must be fairly distributed among all participants in the system to inspire fairness and equality. Consumers currently bears the costs for network usage, disregarding resources that often create some problems in the operation and management of the distribution grid. Thus, **new cost allocation methods for future distribution systems should take into account resources that behave both as producers and consumers or create potential network operational problems**. In order to fairly cost allocating all future participants in distribution grids, cost allocation methods concerning such characteristics should be taken into consideration.

In short, there are a number of challenges that require new methods, strategies and tools to operate the electricity markets and the power system under suitable levels of security, competitiveness and equity. More precisely, **new strategies and market designs for competing RES in both energy and reserve markets** should be considered. In addition, the ability of RES to provide reserve/flexibility services to the system operator should be accounted for. The development of **preventive management and operation of the power system**, as well as the proper **cost allocation of system usage** are crucial to the integration of all RES required to meet the target of a power system operating on a 100% RES scenario.

## 1.2 Thesis objectives and contributions

The main goal of this thesis is to propose new methods for solving problems within the market participant and system's point of view by considering the large integration of RES. On the market participant's point of view, the objective is to propose optimal RES offering in short-term electricity markets considering the trading floors with time horizon from day-ahead up to real-time for energy and reserve market products. From the system's point of view, three different objectives are taken into account: (i) a market equilibrium analysis on the impact of RES offering strategies in the electricity market

following the market operator's perspective; (ii) an active operation and management of distribution systems with large integration of DER (mainly RES) following the system operator's perspective; and (iii) cost allocation of distribution network under the new characteristics of all active participants in the distribution system.

All methods are modeled in the form of optimization problems ideal for dealing with the technical and economic aspects of electricity markets and power systems under high levels of uncertain and variable production.

From the market participant's point of view, this thesis considers the design of strategy offering for Wind Power Producers (WPP) in both energy and reserve markets. In future power systems, WPP will be often called to provide reserves, since they actually have the ability to provide, to some extent, ancillary services. Thus, new business models may arise for WPP to play with both market products, i.e., energy and reserve. WPP will be willing to participate in energy and reserve markets, accounting for some profits with regard to the provision of such services. However, penalties for energy and reserve balancing deviations must be taken into account, since WPP can fail to provide the energy and reserve offered in the operational planning phase. In this context, penalty schemes for reserve imbalance should be considered, aiming to fairly penalize WPP for their deviation (since it is quite harmful to the system, when such imbalance occurs in reserve provision, compared with energy service), although including incentives for the participation of WPP in this service. Within this scope, several works included in this thesis (Paper C, D and F) provide a number of contributions, as well as the development of innovative and realistic methods to the literature. The main contributions under the market participation perspective are fivefold:

- Conception and design of strategy offering for WPP in both energy and reserve markets;
- Implementation of distinct wind control policies for the splitting of available wind power in energy and reserve offers;
- Market design of prices and penalties for wind participation in reserve markets. An intuitive relationship between prices and penalties of energy and reserve market defines the willingness of WPP to participate in one or both markets;
- A new concept for different splitting of energy and reserve offers between day-ahead and balancing stages is proposed. This concept is based on allowing WPP using better information of their forecast production when closer to real-time, thus improving the decision-making process and consequently their expected revenue;
- The evaluation of distinct methodologies for performing the optimal offering problem in both energy and reserve markets, accounting for balancing costs. At this level, four distinct methodologies were developed to analyze the behavior of the WPP's offering in both markets. To some extent, the developed methods

allow WPP to perform the offers in the market under different levels of conservative and non-conservative behavior.

From the system's point of view, the penetration of RES in energy and reserve markets and in power system operation raises some important considerations, especially with regard to the operation of the electricity market and power system, more specifically the distribution grids. In fact, the main contributions of this thesis from the market and system operator's point of view are threefold:

- From the market operator's perspective, bringing wind to reserve markets forces, to some extent, the market operator to deal with the uncertainty in a market that is designed to ensure reliability, which is unavoidable. Thus, reserve market redesign is required in order to face this issue. The approach proposed in Paper C, D and F (penalty scheme for wind producers failing to provide reserve) is one of the simplest approaches to perform in the market allowing wind producers to provide reserve. However, the reserve penalty should be well defined by the market operator in order to accomplish the participation of wind power in the reserve market and, at the same time, maintain proper reliability levels. On the other hand, the impact of such approach on the energy market equilibrium should be accounted for, once the available wind power is divided toward both energy and reserve market products. Within this scope, Paper B contributes to a realistic analysis of the energy market equilibrium under WPP participation in both energy and reserve markets. The aim is to analyze the energy market price and social welfare under different levels of the WPP participation in current energy market;
- On the system operator's perspective, penetration of RES may increase the complexity of network management due to the intrinsic characteristics of these types of resources. For this reason, sufficient flexibility levels are highly important for the secure operation of the power system. In fact, this issue becomes crucial at the distribution level, since large penetration of DER (mainly composed of RES with feed-in tariffs) have direct influence on the system management. For instance, cases of voltage problems and network congestion due to intensive located PV production may arise in the distribution grid. Thus, a proper operation of distribution systems is essential for the use of flexibility, which can be provided by DER in the management of these problems. Within this view, the current practice of DSO operation must change. The current reactive management of the network by the DSO does not consider such tools in order to face the challenge. Thus, a preventive distribution management has been studied in the literature to manage the network under these new characteristics. Within this scope, Paper E provides a significant contribution by proposing a robust active management of distribution grids by contracting flexibility to DER. The goal of this work is to provide an extra tool for the DSO



in network management. The design of a new market product where DER offer upward and downward flexibility to the DSO is developed. The DSO may schedule the most convenient offers by minimizing the cost of contracting this service, by taking into account the intrinsic characteristics of the network and DER, solving voltage problems and network congestion;

- The cost allocation for using the distribution network has been associated to consumers in the past, since the power flow has always flowed in one direction. However, with the continuous integration of DER, different directions of power flow occur in the distribution grid, and therefore traditional cost allocation methods are no longer valid. In this respect, cost allocation methods must consider network usage by DER, either for their own benefit on delivering energy or for providing services to the system. Additionally, future distribution grids will integrate other DER with special characteristics, i.e., ESS and EV with vehicle-to-grid ability, which can be identified either as consumers or producers, depending if they are in the charging or discharging process. These devices have also the ability to store energy that increases the flexibility of the system. Thus, new methodologies adapted to the new system's characteristics must have a proper cost allocation of network usage. Within this scope, Paper A proposes a new cost allocation methodology for this new operation paradigm, as the main contribution. The cost allocation methodology considers a fair mechanism that shares the costs of network usage through DER and consumers. The method traces the power flow in the system and allocates the costs according to the impact of each DER and consumer on each line of the network. In addition, a new inefficiency penalty scheme to ensure full sustainability of the model is performed. This work allows system entities to fairly distribute the costs of using the distribution network through the impact that each user has on the system.

### 1.3 Thesis structure

The thesis is structured as follows. Part I introduces and describes the main concepts addressed in this thesis, while summarizing the main contributions of the papers developed and published during the PhD project. Within this part, Chapter 2 contains an overview of the basic concepts of electricity markets, as well as the integration of renewable generation in electricity markets and power system problems. Chapter 3 provides an introduction to optimization under uncertainty and relaxation techniques, covering the topics of two-stage stochastic programming, robust optimization, linear and piecewise linear decision rules, as well as the McCormick convex relaxation technique. Chapters 4 and 5 outline the main methodological aspects and summarize the results of the research papers included in this thesis. Chapter 4 focuses on the wind offering problem in energy and reserve markets within the perspective of the WPP. On the other hand, Chapter 5 addresses the impact of the integration of renewable energy

resources on the electricity markets and on the distribution system comprising both market and system operator's perspective. Finally, Chapter 6 gathers the most important conclusions and suggestions for future research.

Part II includes the publications that contribute to this thesis.

Paper A is a journal article published in *Electric Power Systems Research* (2015). This paper covers the topic of cost allocation tariff to different actors in the distribution systems. A fair cost allocation method for assessing the use of the distribution system by all system actors (e.g., DER) was developed. Moreover, the method includes fixed and variables costs for the use of the distribution system.

Paper B is a peer-reviewed article published in the Proceedings of the 18<sup>th</sup> Intelligent Systems Applications to Power Systems Conference (2015). This paper uses a multi-agent system (namely, MASCEM) for the evaluation of the day-ahead market equilibrium of the MIBEL electricity market considering the application of proportional control policy in wind power offers.

Paper C is a journal article published in *IEEE Transactions on sustainable Energy* (2016). This paper provides an analytical approach for the optimal offering of wind power plants in both energy and reserve markets. Furthermore, the proportional and constant control policies for the splitting of wind power in energy and reserve, while maximizing the profit of wind power plants is performed.

Paper D is a peer-reviewed article published in the *Journal of Physics: Conference Series* and presented in the *WindEurope summit* (2016). An optimal offering for wind power in energy and reserve markets considering proportional strategy as control policy and using stochastic programming framework is developed. This paper introduces a new concept where the share of energy and reserve in the balancing market can be different from the share of energy and reserve in the day-ahead stage. This concept allows wind power plants to improve their expected revenue.

Paper E is a journal article submitted in *IEEE Transactions on Smart Grid* (under review). The topic of this paper is the value of DER in providing upward and downward flexibility to the DSO, helping the system management and solving congestion problems. It provides a robust framework to DSO in order to contract proper levels of flexibility for grid management.

Paper F is a journal article submitted in *Wind Energy journal* (under review). This paper proposes the use of different optimization tools (namely, stochastic programming by considering McCormick envelopes for convex relaxation of bilinear constraints and piecewise linear decision rules) to solve the wind power offering problem in the energy and reserve markets. Furthermore, a comparison of the proposed methods led to an analysis able to distinguish conservative and non-conservative behavior.



# Renewable Energy Integration in Electricity Markets

---

The current integration of RES in power systems and therefore in electricity markets has been slowly changing the way as electricity markets deal with uncertain power production. A well-functioning electricity market is essential for achieving a future reliable and cost-efficient operation of the power system. Thus, a turning point must be achieved with RES being part of the solution for energy and reserve procurement, while accounting for their intermittent and uncertain production.

This chapter provides an overview of electricity markets structure and organization, while discussing the challenges from the large-scale integration of RES. Furthermore, the impact of DER in distribution system operation and management is addressed. Section 2.1 describes the main concepts related to the current electricity markets designs, focusing on the main principles of the European and US markets operation. The main properties and impact of existing support schemes and trading of renewable production in electricity markets are presented in Section 2.2. Section 2.3 aims to outline the main challenges of current and future market and system operation designs, considering that RES offer and compete in both energy and reserve markets. The integration and impact of DER in future power systems with preventive management and operation of the distribution grid by the DSO is also undertaken in this section.

The interested reader is referred to [9] for a comprehensive overview of electricity market fundamental principles. Additionally, an in-depth discussion of the recent trend in the scientific community on the preventive management of DSO in the distribution grid, through contracting flexibility from DER is provided in [10], [11].

## 2.1 Electricity market designs

The current electricity markets have been modeled based on the conventional characteristics of power systems. In fact, the design sustains assumptions based on fully dispatchable and controllable power generation considering known operational costs and technical constraints of their flexibility. The market operation is settled based on

sequential clearing of several trading floors in a temporal horizon, i.e., from 36 hours-ahead up to real-time operation. These general market characteristics are suitable to deal with the traditional demand-side and system uncertainty. A general market structure of the electricity markets is illustrated in Figure 2.1. The electricity markets are currently divided in several markets, such as the financial, day-ahead, intraday and real-time market for energy delivery. During this process, ancillary services are also procured in the market, following different characteristics and structures depending of each country/region of the power system, i.e., ancillary services are modeled following intrinsic characteristics of the power system to which they belong.

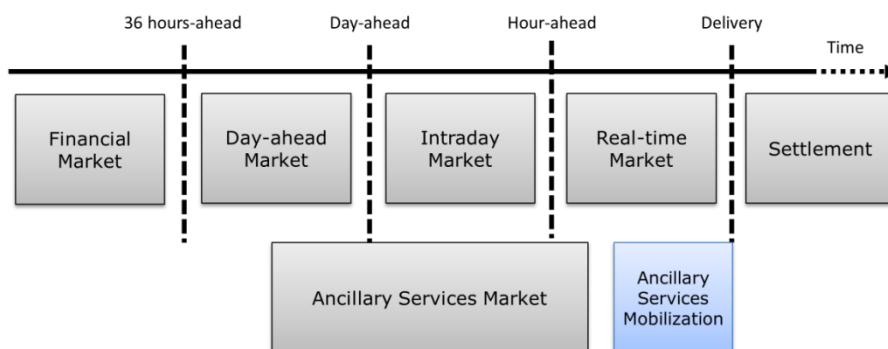

Figure 2.1 – General structure of electricity markets

Nevertheless, different countries and regions may have distinct market operation. For instance, the US and Europe has a different way of operating the electricity markets. Figure 2.2 shows a higher resolution of the different ways of operate traditional electricity markets considering both the US and European perspectives.

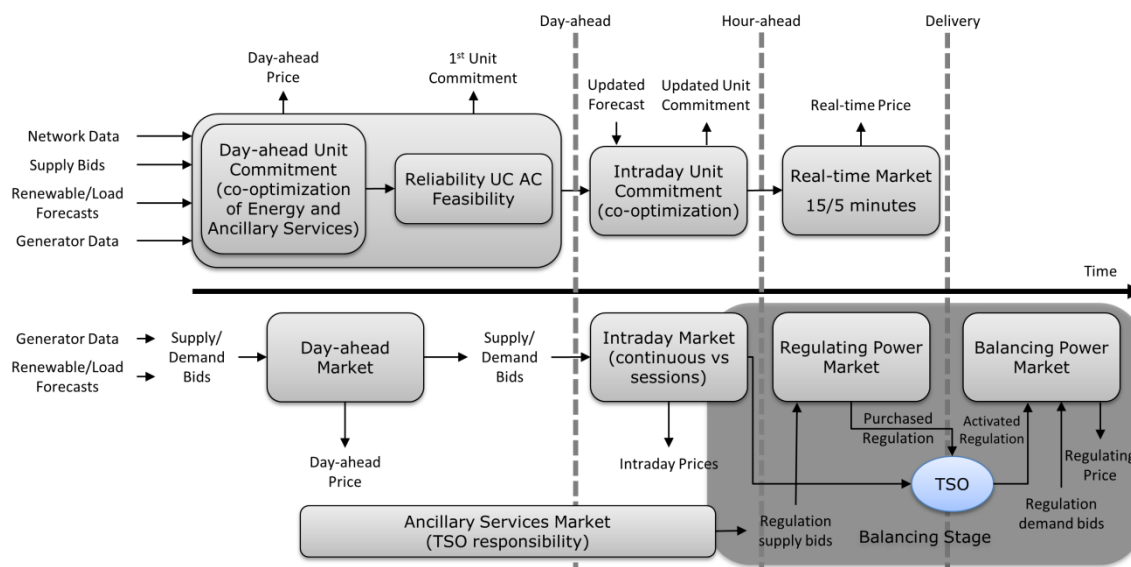

Figure 2.2 – Electricity market designs for US (top) and Europe (bottom). Adapted from [12].

Both market structures comprise three main levels for short-term trading of electricity depending on the proximity to the time of delivery. The US market design considers nodal pricing design, thereby considering a unit commitment with full information of the network in each market stage. On contrary, in Europe a more decentralized scheme is followed, since the trade is performed regionally following a zonal pricing scheme.

### **2.1.1 Day-ahead market**

The day-ahead market is the market floor where the largest volume of electricity is traded considering supply and demand offers. Typically, this market is cleared from 36 hours up to 12 hours before the delivery of electricity. The supply and demand offers for the next 24 hours in the form of price-quantity is submitted in the market. Then, optimization algorithms schedule the resources with the objective of minimizing the total offer costs of resources committed in the market. Depending of the market characteristics, different algorithms requiring additional input information are considered. In US, a unit commitment considering the network constraints and resources characteristics is considered under a nodal pricing design. Thus, the resources scheduling and nodal price is obtained. In contrast, European markets have a different structure. The market coupling process is based on the maximization of the social-welfare within the limits of the established network capacity by Available Transfer Capacity (ATC) between bidding regions. This market ends up with a resources scheduling under a zonal pricing scheme.

### **2.1.2 Intraday market**

The intraday market was designed for market participants that need to adjust their scheduling under new information of their position in the market [13]. For instance, renewable producers under new updated forecasts, or conventional producers under equipment failures use the intraday market to adjust their participation in the market, hence avoiding penalties on the real-time market. In addition, this market can be also used to adjust the strategic behavior of market participants.

In Europe, there are two main distinct intraday market designs, namely the continuous and session markets [13]. For instance, the intraday market of Nord Pool (Elbas) is a continuous market trading and matching supply and demand offers, following the first-come, first-served principle. On the other hand, the Iberian intraday market follows a different approach. The market clears six trading sessions (in different time steps), taking place at each crossing of a marginal nature between supply and demand curves [14]. In this context, the liquidity of the intraday market in Nord Pool and in MIBEL highly depends of the intrinsic characteristics of each market [15]. In fact, Elbas performs a low volume of trading, while the opposite occurs in the MIBEL [13].

### **2.1.3 Real-time and balancing market**

The real-time market is a spot market to procure energy and ancillary services, and manage congestion, as well as outages of generation units and transmission lines disconnection in the real-time after all the other market processes have run. This market procures energy to balance instantaneous demand, reduce supply if demand falls, offer ancillary services as needed and in extreme cases, curtail demand. Furthermore, it is the last market instance for renewable production and demand correct their imbalances due to forecast errors. In short, this market is used to compensate for energy deviations in real-time from the day-ahead and intraday schedules.

The real-time market in US allows market participants to buy additional power to correct their imbalances. In California, the real-time market consists in three distinct processes [16]: the Real-Time Unit Commitment (RTUC); the Short-Term Unit Commitment (STUC); and the Real-Time Dispatch (RTD). The RTUC runs every fifteen minutes and uses an optimization algorithm, referred to as Security Constrained Unit Commitment (SCUC), to commit fast-start units and to procure any necessary ancillary service. The STUC runs once per hour near the top of the hour and uses the SCUC optimization to commit medium-start, short-start and fast-start units to meet the demand forecast. The RTD uses a Security Constrained Economic Dispatch (SCED) algorithm every five minutes throughout the trading hour to determine optimal dispatch instructions to balance supply and demand.

Regarding the European paradigm, real-time markets are usually divided in two-stage markets, namely regulating and balancing power markets (see Figure 2.2 for detail) [17]. It is noteworthy that these markets are run by the local Transmission System Operator (TSO). The regulating power market consists in the TSO purchasing the required upward and downward regulating power to balance the system. In contrast, in the balancing power market, the TSO acts as a seller, by selling the volume purchased in the regulating market to all market participants who actually deviated from their initial schedule. This selling process is made under the balancing prices.

### **2.1.4 Ancillary services / reserve market**

The procurement of ancillary services in the electricity markets is addressed in different ways, depending on the market design and power system rules. In fact there are several different ancillary services with distinct characteristics used to meet the specific needs of the power system, thus maintaining proper levels of security and reliability of the system. The ancillary services are commonly divided in three categories: Services related to frequency control; voltage control; and system blackstart. This thesis refers to the reserve services from frequency control category. For a survey on current ancillary services market in Europe and US, the reader is referred to [18] and [19], respectively.

Broadly speaking, in Europe, reserve services are procured through capacity markets managed by the local TSO. This market can run in parallel with the day-ahead markets

for energy, where energy recourses assume the commitment of being ready to provide the service when the TSO calls them, under the revenue of a capacity payment. In US, an auction for reserve services is considered. The energy and reserve auctions are co-optimized together, hence reducing the general costs for running the system.

## **2.2 Renewables in electricity markets**

The electricity markets characteristics have been changing in the last years with the continuous penetration of renewable sources, namely wind power. Indeed, wind power generation has been increasing year after year in the power system playing now a more active role in the electricity markets [20].

### **2.2.1 Current support schemes**

Currently, wind power generation is one of the main energy resources in the energy mix in several countries, such as Denmark, Germany, Netherlands, Portugal, Spain and USA. This growth of wind power generation has become possible due to the high governmental incentives in most of the countries. However, in most of the European countries, governments are revising the renewable generation support schemes, thereby trying to reduce the incentives on feed-in tariffs forcing wind power generation to compete side-by-side with other players in the electricity market [21]. Under this new challenge, the most common and actual schemes for remunerate wind power generation in Europe are threefold: *(i)* feed-in tariff, *(ii)* feed-in premium tariff and *(iii)* remuneration by market price plus renewable obligation certificate price (also so called as renewable portfolio standards in U.S.) [21]. The traditional feed-in tariff is a scheme that establish a fixed price for the total wind power generation provided to the network [22]. The feed-in premium tariff is a variant of the traditional feed-in tariff, which establishes that the WPP is paid at the electricity market price plus a fixed regulated premium for producing renewable generation [21]. The last support scheme is the most competitive in terms of market perspective. In this scheme, the WPP submits its offer in the energy market and is remunerated according to the market clearing price. Moreover, the WPP get green certificates according to the produced energy, thereby the WPP may trade these certificates in a specific market to increase its own revenue [21].

### **2.2.2 Impact on electricity markets**

Once RES marginal cost is close to zero, or even negative if incentive schemes award is on top of the clearing price, the offers from RES enters directly to the left-hand-side of the supply curve in the market, as can be seen in Figure 2.3. In other words, renewables producers are scheduled before conventional producers, thereby their output directly influences the market clearing price [3]. Thus, the energy market price tends to decrease as long as increases wind power participation in the market. However, this conclusion is not straightforward, since RES have uncertain production, so the price volatility is considerably higher. For instance, in periods with high renewable production, the



amount of scheduled production and consumption will increase, while the market price will be low. On the other hand, in periods with low renewable production, lower production and consumption will be scheduled, resulting in significant higher market prices.

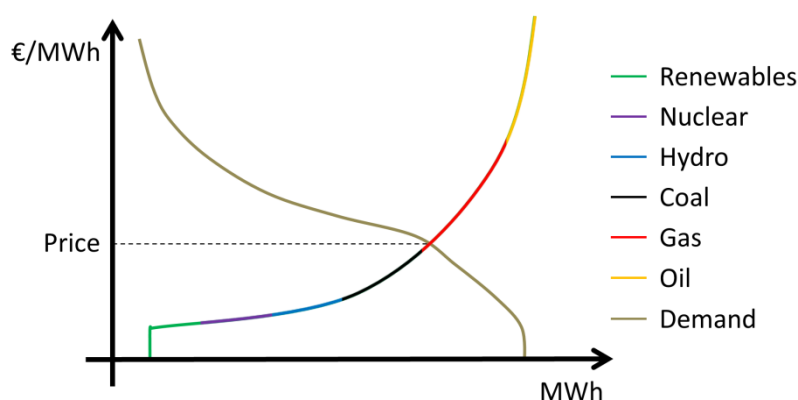

Figure 2.3 – Illustrative example of supply and demand curve by technology.

In electricity markets under high level of RES penetration, the real-time market will be of special importance to RES producers, since it is the last market instance for them to adjust their initial scheduling. Consequently, balancing costs will increase since more reserve will be required to cope with uncertainties during real-time operation.

### 2.2.3 Renewables producers trading in the electricity market

In the scope of RES impact in the electricity market, RES producers (mainly WPP) must consider several aspects when offering in the market:

- Firstly, its technical characteristics, i.e., wind power units are non-dispatchable and characterized by their uncertain production and intermittency. Thus, their decisions in the day-ahead market should consider the risk of failing to supply the volume offered in the market;
- Secondly, the marginal cost for operation is close to zero, since there is no fuel costs for producing energy;
- Finally, renewable producers still count with support schemes from governments for producing clean energy, thereby renewables producers set offers at low price in the market to ensure that they are scheduled.

In this context, the participation in the electricity market is most likely made in two stages. WPP offers an expected available wind power in the day-ahead market, while accounting for balancing costs in the real-time market, covering its energy imbalances. Therefore, placing the optimal offering in the day-ahead market is fundamental for WPP to reduce potential balancing costs from the real-time market. The offering strategy of the WPP aims to maximize the expected revenue from its participation in the day-ahead market, while minimizing the cost of covering its eventual energy deviations in the balancing market.

## **2.3 Challenges for current and future market designs**

Current electricity markets have been facing the challenge of massive integration of renewable power generation into the power system, adapting its design and operation. Additionally, such integration requires changes and a partial restructuring of the market and power system operation, by which the power system is not adapted for.

### **2.3.1 Capacity markets**

Capacity markets have become an important feature of restructured electricity markets. Ultimately, they have been designed to provide revenue sufficiency and assure reliability where the energy market may not cover the long-term cost of conventional generation. This type of market assures the reliability of the system by contracting enough generation and flexibility, preventing the possibility of future blackouts. Indeed, the aim of this market is to ensure sufficient capacity to meet the anticipated needs of the system, especially power systems with high penetration of RES, where flexibility levels are considerably higher and more important. The capacity market is therefore used to produce sufficient revenues for conventional producers to keep them available to provide flexibility when needed.

The massive introduction of RES has significant implications for these capacity markets. Indeed, the increasing share of RES in the system will induce a greater need for capacity payments to conventional generation providing flexibility, which means an increase in the market price. In a more detail way, RES reduces the revenue and energy scheduled of conventional producers in the energy market, since RES has a nearly zero production cost and dispatch all available power in the energy market. On the other hand, increasing RES production requires higher flexibility requirements, which leads to more operation flexibility of conventional producers, thus increasing the operation cost of conventional producers. In general, these characteristics reduce the energy revenue of conventional producers in the energy market, leading to a need for higher capacity payments in the capacity market. These implications are likely to be mitigated in future electricity markets considering new designs of electricity market operation, as well as with the recent technological developments of RES, allowing better control of RES production and the provision of some reserve services.

### **2.3.2 Electricity market design regarding uncertainty**

Current electricity markets designs do not properly cover the uncertain production of renewables. In fact, the market follows a sequential and deterministic market design between day-ahead and real-time stages, since the whole information about the future uncertainty is represented through a single-valued forecast at day-ahead stage. Furthermore, the uncertainty of renewable production is cleared during the real-time market with penalties for renewables producers that cannot supply the expected forecast established in day-ahead. In this context, one of the challenges of the current electricity

markets is to revise their deterministic market design by adapting advanced tools able to support decision-making under uncertainty. The use of stochastic integrated market that co-optimizes day-ahead and balancing stages is a proposed path in the recent literature [23]. However, the performance of such model will heavily depend on the quality of the input information, in this case of the forecast information from renewable production. Nevertheless, renewable power producers have a near-zero marginal cost (or even negative in case of subsidies), so that they enter the base of the supply curve, thus, constraining the conventional generation set-points.

### 2.3.3 Renewables in reserve markets

In view of the new possibilities for future electricity market designs, the provision of reserve through RES (mainly wind power) should be taken into account. Current developments of the wind power technology and wind farm control allows WPP to provide distinct ancillary services such as frequency and voltage control. In fact, wind farms are able to [5], [24]–[26]:

- Provide and control active power injection in a few seconds;
- Respond to reactive power demands in less than one second;
- Support and maintain voltage levels;
- Provide kinetic energy (virtual inertia).

In this context, such technological developments will be essential in a 100% RES power system, helping system operators to maintain adequate levels of system reliability. Furthermore, one of the main challenges in future electricity market designs is the conception of an ancillary services market model that allows renewable production participate in the market, while maintaining suitable reliability system levels. In parallel, the high penetration of RES will change the services design, since the reserve requirements may dynamically vary on an hourly or even minute basis, while the system may have lower inertia [27], [28]. Then, WPP must be called to participate under this new services design. New services design according to the new system characteristics with large-scale integration of RES is essential for proper operation of the future power system. Additional challenges and potential market redesigns for ancillary services can be looked in detail in [5], [6].

One way of bringing the RES to the reserve market is by creating incentives for RES offering in this market. Thus, for an optimal integration of RES in both energy and reserve markets, new business models and remuneration mechanisms should be thought of, since current electricity markets rules and mechanisms are not suitable for a fully renewable power system. The challenge is allowing simultaneous offering of RES in energy and reserve market at day-ahead stage, accounting for potential balancing costs during real-time stage. Since, RES (namely wind and PV have uncertain and variable production) face the challenge of guaranteeing that power scheduled as reserve is available at any time without fail, the reserve market must be designed to account for

the possibility of RES not providing reserve. For instance, by introducing penalties in the real-time stage for failing to provide reserve. The penalty for failing the contracted reserve must be well established by the market operator, i.e., the penalty cannot be too low either too high, in order to ensure that renewable producers do not submit reserve offers with low probability of accomplish it neither submitting reserve offers at all. Under this issue, Papers C, D and F presents a significant contribution for the optimal offering of wind power in energy and reserve markets, accounting for energy and reserve balancing penalties.

The goal of this new market design is the joint offers in both energy and reserve markets, as can be seen in Figure 2.4. Under this new market design, WPP are able to submit both energy and reserve offers, while accounting for potential energy and reserve imbalance situations and respective penalties, i.e., the energy and reserve offers submitted in the day-ahead stage consider the potential expected costs in the balancing stage.

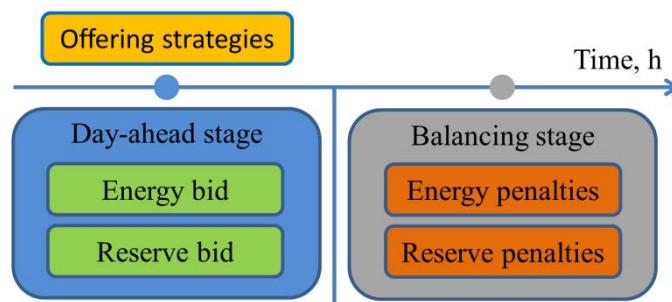

Figure 2.4 – Schematic representation of the market structure for wind offering in both energy and reserve markets.

Additionally, offering strategies can be derived for the joint offering in both markets. In fact, different control policies for WPP split the expected available wind power production in energy and reserve offers are studied, tested and demonstrated in Paper C. Furthermore, Paper D stresses the importance of using the best forecast information (closer to real-time) to reduce expected power deviations in the balancing stage, thereby improving the system reliability and reducing the volatility of the reserve market. Besides this, Paper F proposes distinct approaches to model different degrees of imperfect energy and reserve offering strategies, in some extent discussing the conservative and non-conservative behavior of WPP.

### 2.3.4 Towards a power system based on DER

Moving towards higher shares of renewables in electric power system, aggregators ought to merge the offering of different RES to some extent able to compensate each other for their uncertainty and intermittency, thus providing flexible participation in electricity market, while improving system reliability. Thus, the DER aggregators will be essential to provide flexibility to local electricity markets (probably managed by DSOs), thereby helping to maintain the energy delivery with suitable levels of security

and reliability. Within this scope, new business models for DER aggregators providing local flexibility services will emerge. Section 2.3.4.1 highlights the main characteristics that will result in a power system full of DER. Section 2.3.4.2 provides the latest definition of DER flexibility. In addition, full insights about flexibility of DER in a competitive environment are provided in Section 2.3.4.3.

#### **2.3.4.1 General characteristics of DER**

In last decade, technological innovations on renewables and smart grids together with ambitious environmental targets have increasing the interest of using DER. The main reasons for the recent interest in DER are fivefold:

- The dynamic growth of distributed generation technology industry. The evolution of the technology makes distribution generation more attractive to investors on a small-case business, thereby greater efficiency at lower cost. Furthermore, the flexibility of DER to provide different ancillary services in the system will become crucial to help in the network management. In fact, the DER can improve the quality and reliability of the system by providing voltage support, power factor correction and other ancillary services.
- Limits on building new transmission lines. Transmission network expansion usually faces several issues, i.e., high investment costs, political and environmental concerns. Thus, DER can delay investments in transmission lines, since the distributed generation (such as PV) can reduce congestion of current lines at the transmission and distribution levels.
- Increased customer demand for highly reliable electricity. Consumers are more demanding for proper levels of electricity supply. Even more in the future because consumers can generate part of their own consumption, demanding high levels of quality and system reliability.
- Deregulation of the electricity sector with special focus in electricity markets opportunities. Small producers are willing to be more involved in electricity markets, thereby increasing its expected revenue.
- Concerns about climate change. Recent trends for a power system for 100% renewable power generation have come to open a new window for government incentives to achieve these targets. Thus, such incentives will partially support continuous development of DER technologies and smart grid concept.

Overall, the combined impact of all these factors continuously boosts the transition from the current power system for a future decarbonized power system. For a comprehensive overview of the general characteristics of DER, the interested reader is referred to [29]–[31].

#### **2.3.4.2 The new role of flexibility - definition**

In addition to the general aspects, the introduction of DER (mainly RES) into the power system makes system planners and operators recognize the need for new ways of balancing supply and demand. In fact, the developments in DER technology enable them to contribute to this new era of services to maintain the system security and reliability [32], [33]. Thus, the concept of DER flexibility in the literature gains importance for the future management of power system, especial in the distribution systems. Recently, the concept of flexibility has been defined and intended as:

*“On an individual level, flexibility is the modification of generation injection and/or consumption patterns in reaction to an external signal (price signal or activation) in order to provide a service within the energy system. The parameters used to characterize flexibility in electricity include: the amount of power modulation, the duration, the rate change, the response time, the location, among others.”*[34]

In this context, different DER technologies are capable of providing flexibility from different levels and technical aspects. In the remainder of this thesis, the term flexibility refers as the amount of power provided by DER that can help the system operator managing the system. This concept includes upward flexibility that means DER providing additional power as needed to maintain system balance, and downward flexibility that means reducing the power availability in the system.

#### **2.3.4.3 Flexibility of DER in a competitive environment**

In line with the aforementioned developments and definitions, a future power system with DER partly supporting the system needs is part of smart grid paradigm, which is gaining consistency in the literature in recent years, regarding the operation and management of future power systems [35]–[37]. Under such circumstances, the flexibility of DER to provide ancillary services will be crucial for a proper management of the distribution network, even under different power flow directions and network congestion. However, the variability and intermittency of RES is a challenge for the DSO operation. In addition, the new preventive management methodologies of distribution grids must take into account congestion and voltage problems that may appear on the network. In fact, the presence of DER should help the DSO to solve potential congestion problems, thus deferring network reinforcement. Furthermore, the DSO can also use the flexibility of DER to solve potential voltage problems in the network. It has been deeply studied that the DER can create some voltage problems in the distribution grid from time to time, depending on the consumption in that network location, especially in network locations with high penetration of PV generation and EV. Thus, the flexibility from these distributed generation units can be crucial for the DSO to correct voltage levels and ensure smooth energy delivery to consumers. Within this scope, Paper E contributes with a new approach that allows the DSO managing

network congestion under high levels of uncertain power production by contracting upward and downward flexibility to the DER. In fact, the use of this approach relieves the congestion of the main branches of the distribution network.

Despite the high integration of DER in future power system, this paradigm will bring new challenges. In fact, small producers and consumers will compete partially by the use of the network, since consumers are an active participant in the system by behaving as a producer/consumer by injecting/absorbing power on the network (through PV, ESS, EV with vehicle-to-grid ability, and demand response). In this context, new tariff schemes for the cost allocation of using the network should be rethought. Indeed, the cost of using the network may consider the impact of all distribution system participants in a fair and distributed way. To this end, Paper A contributes with a model that fairly allocates the cost of using the distribution network to all network users. The model considers different costs (namely fixed, losses and congestion costs) allocated to a large set of DER (e.g., distributed generation, demand response, ESS and EV with vehicle-to-grid ability) and consumers. In short, this work proposes that all system participants with impact on the network flow must share part of the management and operating costs.

# Optimization under uncertainty

---

The increasing penetration of RES in power systems requires the change of the traditional optimization approaches to solve power system problems, since RES has intermittent and variable production. In this context, new ways of solving the problems taking into account the uncertain behavior of RES should be investigated. The problems considered in this thesis require the use of different optimization techniques able to cope with the uncertain and variable production of RES, in particular, stochastic programming, Linear Decision Rules (LDR) and robust optimization.

Nonetheless, the use of these techniques requires the basic knowledge of linear and nonlinear optimization. For a deep discussion on linear and nonlinear optimization theory, the interested reader is referred to [38] and [39], respectively. In addition, relaxation techniques are also important for the linearization of nonlinearities. For example, McCormick envelopes can be used to linearize bilinear terms to make problems linear and convex [40]. This chapter depicts the fundamental concepts of the optimization techniques used in this work. Section 3.1 provides the basic concepts and differences of optimization in linear and non-linear programming. Section 3.2 presents the McCormick envelopes technique to handle bilinear constraints, by generating equivalent convex constraints.

Problems under uncertainty can be performed through different optimization techniques (e.g., stochastic programming, robust optimization and LDR), by which the adequacy of each technique depends on the level of available information of the uncertain parameter, as well as the goal of the decision maker. Applications of stochastic, robust and LDR optimization related to clearing and trading in electricity markets are presented in [3] and [41], [42]. In the literature, an exhaustive detailing of stochastic programming is given in [43]. Section 3.3 provides the basic concepts of two-stage stochastic programming used in several papers included in Part II. Robust optimization is designed to ensure decisions based on conservative behavior. A special variant of robust optimization is adaptive robust optimization. This optimization technique stands out for its ability of decision-making based on the worst-case scenario. All the theory behind adaptive robust optimization is discussed in [44]. Section 3.4 describes the main principles of robust optimization with special focus in adaptive robust optimization.



Finally, LDR and Piecewise Linear Decision Rules (LDR) are techniques that have a different way of modelling recourse problems in addition to stochastic and robust optimization. In fact, such a technique is suitable for modeling problems where uncertainty information is limited. For further details on recourse function modeled by linear and piecewise linear functions, the reader is directed to [45] and [46]. Section 3.5 presents an introduction to the LDR and PLDR to deal with uncertain production.

### 3.1 Basics of optimization

In the scope of this thesis, linear and nonlinear optimization has been used to model certain power systems problems. Thus, convex optimization models are introduced in Section 3.1.1, duality theory is discussed in Section 3.1.2, while the motivation for using nonlinear optimization is explained in Section 3.1.3. The aim of this thesis is to provide optimization models for modelling power systems problems under the new challenges, rather than algorithms for solving these models. Instead readers are suggested to consult CPLEX [47] algorithm that has been used for dealing with linear optimization and mixed integer optimization, while for non-linear optimization CONOPT [48] algorithm was employed. All mathematical models developed in this thesis has been modeled under GAMS [49] modelling language with connection to the MATLAB<sup>1</sup>.

#### 3.1.1 Linear programming

A convex optimization problem is a problem considering convex functions and sets. By definition a convex function is a “*continuous function whose value at the midpoint of every interval in its domain does not exceed the arithmetic mean of its values at the ends of the interval*” [50], [51]. Thus, for an optimization problem being convex some conditions should be ensured:

- a differentiable and convex objective function;
- differentiable and convex inequality constraint functions;
- affine equality constraint functions

Linear programming is a special instance of convex optimization problems. A linear program is generally modelled such as:

$$\text{Min}_x C^T x \tag{3.1a}$$

$$\text{s.t.} \quad Fx = f, \tag{3.1b}$$

$$Gx \leq g, \tag{3.1c}$$

where the objective function is given by (3.1a).  $x$  represents the vector of decision variables and  $C$  the vector of cost coefficients. Constraint (3.1b) represents the equality

---

<sup>1</sup> MATrix LABoratory (MATLAB), The MathWorks, Inc., Natick, United States, 2014

constraints of the system with  $F$  being the matrix of the decision variables vector and  $f$  the right-hand side vector of the constraint. The inequality constraints are represented by (3.1.c). Together, (3.1b) and (3.1c) determine the feasible region of the problem.

In the scope of power system operations, optimization problems considering the optimal operation schedule follows the minimization of operation costs, thereby maximizing the social welfare. Linear programming served as the basis for the optimization models developed in all works presented in Part II.

### 3.1.2 Duality theory

Duality theory [38] is of great importance in the field of optimization, since it can give different interpretation of the problem. For instance, in scheduling problems (such as in electricity markets), duality can provide economic signals of the system limitations that can be further interpreted and properly analyzed.

Nevertheless and in terms of duality theory, let's assume that the linear optimization problem (3.1a) is the primal problem and associate the dual variable  $\alpha$  to the equality constraint (3.1b) and the dual variable  $\mu$  to the inequality constraint (3.1c). Following duality theory, the Lagrangian function of the entire problem (3.1) is obtained through:

$$\mathcal{L}(x, \alpha, \mu) = C^T x + \alpha^T (Fx - f) + \mu(Gx - g). \quad (3.2)$$

Thus, the dual problem takes the form of:

$$\text{Max}_{\alpha, \mu} \quad -f^T \alpha - g^T \mu \quad (3.3a)$$

$$\text{s.t.} \quad F^T \alpha + G^T \mu = -C, \quad (3.3b)$$

$$\mu \geq 0, \quad (3.3c)$$

The dual variables of the problem represent the shadow prices of the associated constraints.

For instance, considering the primal problem as simple economic dispatch, the marginal price of electricity is given by the dual variable of the power balance of the primal problem ( $\alpha$ ). In other words, an increase of the decision vector  $x$  by one unit, will increase the system cost by  $\alpha$ .

Another two important properties associated with the primal and dual problems are:

The weak duality property states that: if  $x$  is a feasible solution of the primal problem (3.1) and  $(\alpha, \mu)$  a feasible solution of the dual problem (3.3), then

$$C^T x \geq -f^T \alpha - g^T \mu. \quad (3.4)$$

On the other hand, the strong duality property states that: if  $x^*$  is the optimal solution of the primal problem (3.1) and  $(\alpha^*, \mu^*)$  the optimal solution of the dual problem (3.3), then

$$C^T x^* = -f^T \alpha^* - g^T \mu^*. \quad (3.5)$$

### 3.1.3 Nonlinear programming

The nonlinear programming is the process of solving the optimization problem where some of the constraints or the objective function are nonlinear [39]. For a better understanding of the subject, let's define that nonlinear functions are all the functions that are not linear, i.e., functions that have different properties from linear functions. A special example of a nonlinear function is the quadratic function (Figure 3.1), which is not linear, but is convex. An optimization model with this type of functions can be solved by using quadratic programming, since this function is convex and can be solved in polynomial time. For instance, in power systems, this type of function is used to model the fuel-cost curve of thermal generators. In Paper A, quadratic functions have been used for modeling the fuel-costs of combined heat and power plants.

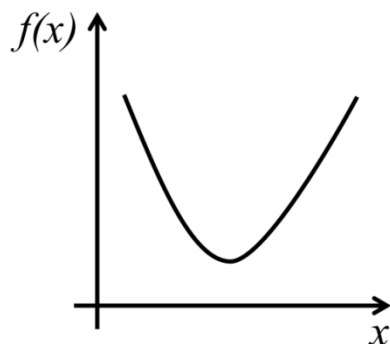

Figure 3.1 – Example of a quadratic convex function.

Nevertheless, other functions such as trigonometric functions are nonlinear and are neither convex nor concave functions (e.g., Figure 3.2). Trigonometric functions (such as sine and cosine) are included in the modulation of a full Alternating Current Optimal Power Flow (AC OPF). Paper A and E comprise the modulation of these functions to ensure a proper and accurate power flow in the electric system.

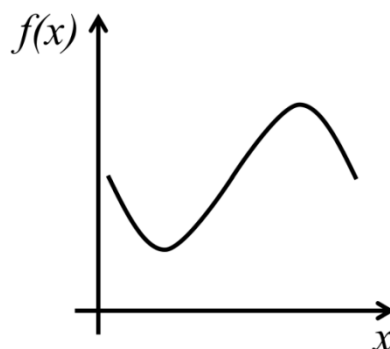

Figure 3.2 – Example of a trigonometric function.

Besides, other nonlinear functions or constraints can appear in power system problems. For instance, constraints with different linear variables multiplied by each other, forms a

bilinear constraint, which becomes nonlinear. The constraint (3.6) represents a bilinear equation where  $x$  and  $y$  are linear decision variables.

$$xy = f \tag{3.6}$$

In this thesis, bilinear constraints were employed to the model for dealing with a control strategy of wind power plants to split available wind power in energy and reserve, as explained in detail in Section 4. Thus, the modelling of bilinear constraints is presented in Papers C, D and F. Additionally, bilinear constraints can be relaxed through relaxation techniques (such as McCormick envelopes presented in Section 3.2), thereby reducing the complexity of the models. However, this relaxation comes with the cost of accuracy for getting the optimal solution of the problem.

One of the main advantages of the nonlinear modulation is the very close approximation to the natural behavior of power systems. However, this precision comes with the cost of higher complexity of the modulation, as well as, some nonlinear functions used in the power system (such as trigonometric functions) do not guarantee a global optimal solution and is not solvable in polynomial time, which leads to an increase of the computational effort in the simulation process.

In what concerns to all the details of the duality theory for nonlinear optimization problems, interested readers are referred to [39], [52].

### 3.2 McCormick envelopes

The McCormick envelopes are a type of convex relaxation used to relax bilinear nonlinear problems. The aim is to transform nonconvex functions into convex, by relaxing the bounds of the nonconvex function through a convex relaxation [40]. Thus, the technique can turn bilinear functions into convex function, thereby reducing the computational effort for solving the problem. Another advantage of this technique is the possibility of mitigating local minima to the solvers. However, the optimal solution in the relaxed problem can be different of the optimal solution of the standard problem, i.e., the accuracy of obtaining the optimal solution can be decreased.

Nevertheless, McCormick envelopes provide a good relaxation of bilinear functions by creating tight bounds of the bilinear function, while ensuring its convexity. Let us refer to (3.6) as a usual bilinear constraint where  $x$  and  $y$  are two distinct decision variables. It is assumed that the upper ( $\bar{x}$ ) and lower ( $\underline{x}$ ) bounds of the decision variables are known in advance, which is the case of the proportional control strategy of wind power plants, modelled as a bilinear constraint in this thesis (Section 4). In cases where the upper and lower bounds need to be estimated, the reader is referred to [53].

Following the theory of McCormick envelopes, four different inequality constraints should be modelled, such that

$$f \geq \underline{x}y + x\underline{y} - \underline{x}\underline{y}, \quad (3.7a)$$

$$f \geq \bar{x}y + x\bar{y} - \bar{x}\bar{y}, \quad (3.7b)$$

$$f \leq \bar{x}y + \underline{x}\bar{y} - \bar{x}\underline{y}, \quad (3.7c)$$

$$f \leq x\bar{y} + \underline{x}y - x\underline{y}. \quad (3.7d)$$

A graphical illustration of the four inequality constraints is shown in Figure 3.3. Constraints (3.7a) and (3.7b) represent the red area of Figure 3.3, also called as convex underestimators. Similarly, constraints (3.7c) and (3.7d) define the convex overestimators, which cover the envelope representing the green area in Figure 3.3.

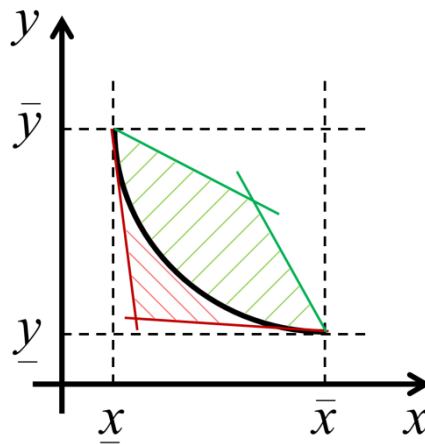

Figure 3.3 – Graphical illustration of McCormick envelopes. The area in red is covered by the convex underestimators constraints, while the green area is delimited by the convex overestimators constraints.

In this thesis, McCormick relaxation is used for relaxing a bilinear constraint modelled for wind power participation in energy and reserve markets (as presented in Paper F). The proportional control has bilinear properties that can be relaxed into convex constraints. Thus, the use of this type of convex relaxation allows transforming the developed nonconvex model into a convex model, thereby decreasing the complexity of the model while ensuring tight bounds for the convex constraints. For bilinear problems requiring higher tightness of the boundaries, the reader is referred to [54].

### 3.3 Stochastic programming

The continuous penetration of RES in power systems requires the system operator to create new models for dealing with the uncertain production of these types of resources. Optimization problems under uncertainty are characterized by the necessity of making decisions without knowing what their full effects will be. In this context, several different methodologies for solving optimization problems under uncertainty are known. One of them is through stochastic optimization.

In this section, the basic concept of a stochastic programming problem is detailed for dealing with uncertainty in power systems. This type of tool is very useful in the

support of decision-making process of different optimization problems. This section focuses on two-stage stochastic optimization problem, since this technique has been used for modelling uncertainty in different papers of this thesis (e.g., Paper D and F).

### 3.3.1 Basic concept

Stochastic programming is one of the most used tools for solving problems under uncertainty. The ability to model problems where uncertainty can realize over different decision horizon, thereby defining a number of stages, makes it a good tool to solve problems and find optimal solution in expectation. Every stage depicts a certain point in time where decisions are made and uncertainty is realized [43]. Commonly in power systems, an optimization problem under uncertainty is modelled as a two-stage stochastic programming, also called recourse problem, where the second-stage is the one that deals with the uncertainty.

Nevertheless, multi-stage stochastic programming problems are often used to model problems where uncertainty takes realization in larger time horizon. The multi-stage stochastic problem (considering more than two-stages) is out of the scope of this thesis. Instead, the reader is suggested to read [43], [55], for a deep knowledge of how to model multi-stage stochastic programming problems.

### 3.3.2 Two-stage stochastic programming

The two-stage stochastic programming problem is a decision-making problem where decisions are made at two stages and there is a stochastic decision variable  $y$  which depends on a set of scenarios  $\Omega$ . The first-stage decision  $x$  is made before knowing the actual value of the stochastic process, while  $y$  is determined after the realization of each scenario  $\omega$  (second-stage). Intuitively,  $y$  will also depend on the decision  $x$  previously made in the first-stage. Thus,  $y$  can be represented as  $y(x, \omega)$ . Thus, the decision-making process consists of making the decision for  $x$ ; then comes the disclosure of the uncertainty by  $\omega$ ; finally decision  $y(x, \omega)$  is made. This process is illustrated by Figure 3.4.

In this context, the two-stage of the decision-making process is characterized as:

- First-stage (*here-and-now*). In this stage, the decision  $x$  is made before the uncertainty disclosure. Thus, this decision variable does not depend on each realization of scenario of set  $\Omega$ ;
- Second-stage (*wait-and-see*). The decision  $y(\omega)$  is performed after knowing the actual realization of the uncertainty. Thus, the variable  $y$  depends on each scenario  $\omega$  of the scenario set  $\Omega$ .

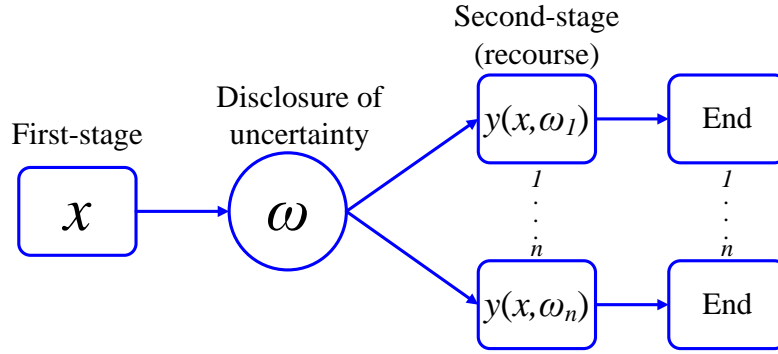

Figure 3.4 – Sequence of the decision-making process for the two-stage stochastic programming (adapted from [12]).

Associated to each scenario  $\omega$ , there is a probability of occurrence  $\pi(\omega)$ . Thus, the generalized mathematical formulation of the deterministic equivalent of a two-stage stochastic problem is expressed as:

$$\text{Min}_{x, y(\omega)} C^T x + \sum_{\omega \in \Omega} \pi(\omega) q(\omega)^T y(\omega) \quad (3.8a)$$

$$\text{s.t.} \quad Fx = f, \quad (3.8b)$$

$$T(\omega)x + H(\omega)y(\omega) = h(\omega), \quad \forall \omega \quad (3.8c)$$

$$x \geq 0, \quad (3.8d)$$

$$y(\omega) \geq 0, \quad \forall \omega \quad (3.8e)$$

where the objective function (3.8a) leads to the minimization of the total cost of both stages, considering the recourse cost of the second stage with weighted probability. Additionally,  $q(\omega)$  stands for the matrix with the costs related to the second-stage decision variable. This problem is subjected to first-stage constraints (3.8b) and to constraints that connect the first-stage decision with the recourse decision (3.8c). Thus, the first-stage decision affects all the matrixes and vectors of the second-stage.

In this thesis, two-stage stochastic optimization has been used as a tool for treat the uncertainty of the WPP offering problem in energy and reserve market. The aim is to find the best offer for energy and reserve that the WPP should submit in both markets, accounting for the uncertainty modelled in the form of a scenario set. This type of tool is appropriate to evaluate the uncertainty under expectation. The behavior and full characteristics of the model are detailed in Section 4, as well as in Papers D and F.

### 3.4 Robust optimization

Robust optimization is a type of optimization that was developed for dealing with the worst-case of the uncertainty in optimization problems. In fact, robust optimization is ideal for the treatment of severe uncertainty in the problems, thereby being based on the worst-case analysis and modelled by the Wald's *max-min* model. Furthermore, robust

optimization is constructed with the aim of obtaining a solution that is feasible for all uncertainty realizations in the uncertainty set and optimal for the worst-case [3].

This section presents the formulation of uncertainty sets (Section 3.4.1) and the general model of adaptive robust optimization (Section 3.4.2) that served as the basis for the work developed during this thesis.

In the electric power system, robust optimization is often used to deal with the uncertainty of RES production, ensuring a solution that is feasible and reliable, thereby guaranteeing the safety of the system in most of the cases.

### 3.4.1 Uncertainty set definition

One of the biggest issues in robust optimization is the need for establishing uncertainty sets, e.g., polyhedral and ellipsoidal uncertainty sets [3]. Uncertainty sets that are not properly modelled considering the intrinsic characteristics of the optimization problem can lead to inappropriate set of vertices that are not truly representative of the worst-case solution, thereby providing solutions that are not robust at all or too conservative. In this context, several forms of constructing the uncertainty set appear in literature, e.g., polyhedral, ellipsoid and scenario set with spatial-temporal correlation are the most common in literature [56].

In the scope of this thesis, the uncertainty set has been modeled through a scenario set with spatial-temporal correlation. Readers interested on the construction of the uncertainty set through polyhedral and ellipsoid are referred to [3], [44] and [57], respectively. The construction of the uncertainty set through a scenario set is threefold:

- Definition of the scenario set  $J$  (previously generated through a scenario generation process considering spatial-temporal trajectories);
- For each period, the deviation between the scenario set  $J$  and the conditional mean value forecast of the set creates a cloud of  $N_j$  points representative of the uncertainty space.
- Finally, the uncertainty set  $W$  is defined as a convex hull of these points constructed through convex hull algorithms.

The cloud's points and the delimitation of the uncertainty set for two random variables are illustrated in Figure 3.5. One of the vertices that delimit the uncertainty set will lead to the worst-case.



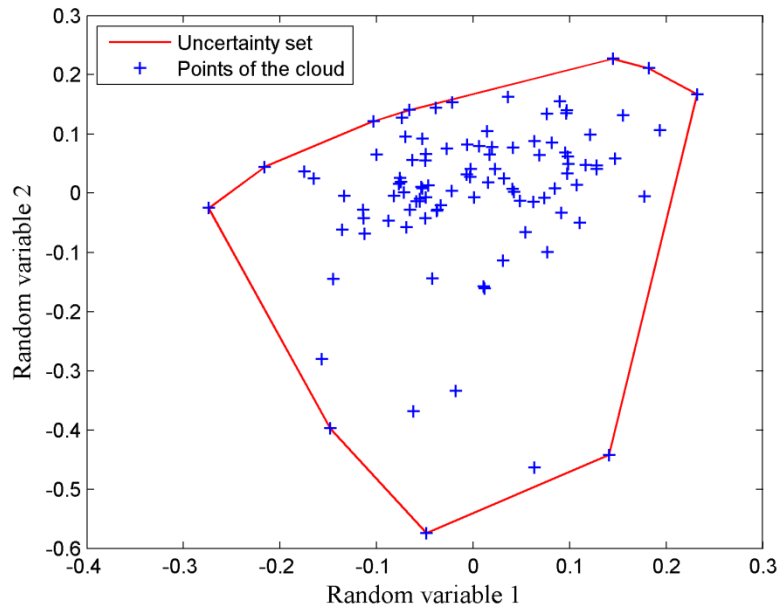

Figure 3.5 – Uncertainty set representation through scenario set with spatial-temporal correlation.

### 3.4.2 Adaptive robust optimization

Adaptive robust optimization is one specific instance of robust optimization that has been used in this thesis. This approach considers a two-stage programming (as the two-stage stochastic programming presented in Section 3.3) with first-stage and second-stage decision variables regarding the decision before and after realization of the uncertainty. The main difference between the adaptive robust optimization and the two-stage stochastic is the modelling of the uncertainty. The adaptive robust optimization aims to select one of the vertices of the uncertainty set that will ensure the worst-case solution [58], [59]. i.e, a unique and reliable solution is obtained from the robust optimization, as illustrated in Figure 3.6.

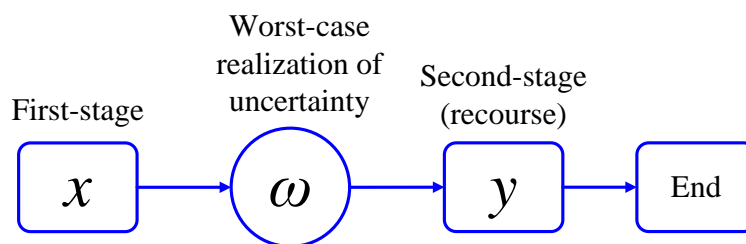

Figure 3.6 – Sequence of the decision-making process for the adaptive robust optimization (adapted from [12]).

Nevertheless, the general representation of the adaptive robust optimization follows a three-level optimization model, which is given by:

$$\text{Min}_x C^T x + \text{Max}_h \text{Min}_y q^T y \quad (3.9a)$$

$$\text{s.t. } Tx + Hy = h, \quad (3.9b)$$

$$y \geq 0, \quad (3.9c)$$

$$\text{s.t. } h \in W, \quad (3.9d)$$

$$\text{s.t. } Fx = f, \quad (3.9e)$$

$$x \geq 0. \quad (3.9f)$$

This problem has a *min-max-min* structure, where the right-hand-side aims at minimizing the cost related to first-stage decisions  $x$  that have to be made before the realization of uncertainty. The decisions under the first-stage are constrained by the constraints (3.9e) and (3.9f). The *max-min* problem represents the second-stage problem, where the aim is to minimize the operation costs of the second-stage decision variable  $y$ , while maximizing the impact of the uncertain parameter  $h$  in the second-stage decision variable  $y$ . The worst-case realization of the uncertainty set  $W$  is enforced by the maximization problem that drives the uncertain parameter  $h$  towards the maximum recourse cost. However, this three-level problem (3.9) cannot be directly solved. Instead, the inner minimization problem can be replaced by its dual problem, using duality theory. This would allow merging the max-min problem in one single problem, thereby called the recourse part of the problem. However, the dual problem of the *max-min* problem adds bilinear terms in the objective function as proven in [3]. Within this scope, [3] proves that for a polyhedral uncertainty set  $W$ , the optimal solution will be at one of the vertices of this set. Thus, an equivalent deterministic problem (3.10) can be modeled by adding an auxiliary variable  $\beta$  that can be used to represent the worst-case of the recourse in the objective function. The auxiliary variable  $\beta$  is constrained by the previous recourse function for each of the finite vertices  $v$  ( $v=1, \dots, v_0$ ) of the uncertainty set. Then, the optimization problem is reformulated in such way that:

$$\text{Min}_x C^T x + \beta \quad (3.10a)$$

$$\text{s.t. } \beta \geq q^T y_v, \quad \forall v = 1, \dots, v_0 \quad (3.10b)$$

$$Tx + Hy_v = h_v, \quad \forall v = 1, \dots, v_0 \quad (3.10c)$$

$$y \geq 0, \quad \forall v = 1, \dots, v_0 \quad (3.10d)$$

$$Fx = f, \quad (3.10e)$$

$$x \geq 0. \quad (3.10f)$$

where all the constraints concerning the second-stage problem are modelled for each of the vertices  $v$  of the uncertainty set  $W$ .

In electric power systems, adaptive robust optimization has been widely used to deal with uncertainty, based on the worst-case scenario. Indeed, this approach is appropriate

for obtaining a solution that is robust for all the cases of the uncertainty, thereby allowing the system to perform high levels of reliability and security. Therefore, robust optimization is of most interest of transmission and distribution operators, ensuring the operation of the system at the lowest possible cost, considering proper levels of reliability. Within this scope, adaptive robust optimization has been used in this thesis to cover the management of a distribution grid with high levels of uncertainty, as fully detailed in Section 5 and Paper E.

### 3.5 Optimization using linear decision rules

The LDR is an approximation of the stochastic programming providing a tractable linear problem at the cost of a potential loss of optimality [45], [60]. The LDR consists in modelling the uncertain decision variable of stochastic model through an affine function. The main advantage of the LDR optimization is that does not require discrete distributions of the uncertain parameters in contrast to stochastic programming. However, the LDR can create an optimality gap, since the uncertain parameter behaves linearly. An improvement of the traditional LDR optimization is the PLDR. The PLDR is able to reduce the gap of the linearization of the uncertain parameter [46].

In electric power systems, LDR has been recently used to solve some problems under uncertainty, in which the uncertainty is modeled by linear functions. In these cases where the goal is obtaining a solution that is neither optimistic (stochastic approach) neither pessimistic (robust approach), LDR are an alternative.

In this section, the LDR and PLDR approximations for the two-stage stochastic programming are discussed on Section 3.5.1 and Section 3.5.2, respectively. This method has been used in this thesis to model the uncertainty and strategic behavior of WPP in the electricity market, as detailed in Section 4.6.4 and Paper F.

#### 3.5.1 Linear decision rules

This section presents the LDR approximation, based on the derivation in [45], [60], yet adjusted to the general formulation of the two-stage stochastic problem presented in Section 3.3.2.

Assuming the two-stage stochastic formulation from (3.8) and that  $\delta$  is the random variable, the following affine dependency of the second stage decision  $y(\delta)$  variable is given by

$$y(\tilde{\delta}) = \hat{y} + K^y \delta, \quad (3.11)$$

where  $\hat{y}$  represents the expected mean realization of the decision variable  $y$ , and  $K^y$  the slope of the affine function. All variables related with the second-stage problem should be modelled with affine dependency, once it is considered that the uncertain parameter behaves linearly. Problem (3.8) has only one second-stage variable.

Additionally, the recourse variable  $y$  needs to be positive.

$$\text{Min}_x C^T x + \mathbb{E}\left(q^T (\hat{y} + K^y \delta)\right) \quad (3.12a)$$

$$\text{s.t.} \quad Fx = f, \quad (3.12b)$$

$$x \geq 0, \quad (3.12c)$$

$$Tx + H(\hat{y} + K^y \delta) = h, \quad (3.12d)$$

$$\hat{y} + K^y \delta \geq 0. \quad (3.12e)$$

It is assumed that  $T$ ,  $H$  and  $h$  are a known matrixes and vector not depending of the uncertainty. Within this scope, the optimization problem in the form of (3.12) need to be reformulated reaching a single-level reformulation of the stochastic problem with LDR. The problem reformulation is divided through equality constraints (Section 3.5.1.1), inequality constraints (Section 3.5.1.2) and objective function reformulation (3.5.1.3).

### 3.5.1.1 Equality constraints reformulation

Let us consider the equality constraint (3.12d) of the second-stage problem for reformulation. Following [45], [61], this equality constraint is reformulated in a way to eliminate the random variable and assure finite cardinality, hence

$$Tx + H\hat{y} = h, \quad (3.13a)$$

$$HK^y = 0, \quad (3.13b)$$

where equation (3.13a) must hold in the nominal case, i.e., for  $\delta=0$ . Additionally, equation (3.13b) ensures that the balance in the equation holds for any realization of  $\delta$  in the uncertainty set  $W$ .

### 3.5.1.2 Inequality constraints reformulation

Let us consider the inequality constraint (3.12e) of the second-stage problem for reformulation. By replacing the LDR for the recourse decision variables, this inequality is formulated as

$$\text{Min}_{\delta} \left\{ K^y \delta, \right. \\ \left. \text{s.t.} \quad M_j \delta \geq m_j : \alpha_j, \quad \forall j \right\} \geq -\hat{y}, \quad (3.14a)$$

where  $\alpha_j$  is the dual variable associated to the  $j$ -th inequality constraint,  $M_j$  and  $m_j$  represents the left-hand-side and right-hand-side of the uncertain parameter constraints, which in this case is modeled by its upper and lower bounds. Following duality theory [38], [45], the minimization problem (primal) on the left-hand-side of the inequality (3.14a) can be replaced by its dual (maximization problem), as

$$\text{Max}_\alpha \left\{ \begin{array}{l} \sum_j m_j \alpha_j, \\ \text{s.t. } \sum_j M_j \alpha_j = K^y, \\ \alpha_j \geq 0, \quad \forall j \end{array} \right\} \geq -\hat{y}, \quad (3.14b)$$

Thus, the equivalent representation of the dual problem in a system of constraints follows

$$\sum_j m_j \alpha_j \geq -\hat{y}, \quad (3.15a)$$

$$\sum_j M_j \alpha_j = K^y, \quad (3.15b)$$

$$\alpha_j \geq 0, \quad \forall j \quad (3.15c)$$

where the set of inequalities (3.15) has finite cardinality. Moreover, all recourse decisions variables (in its piecewise linear form 3.12e) from the second stage problem are positive variables, being required performing similar reformulations to all these inequality constraints affected by the uncertainty.

### 3.5.1.3 Objective function reformulation

The part of the objective function regarding the second-stage decision (3.12a) has been reformulated taking the expectation over the uncertain parameter. By exploiting linearity and assuming that the uncertain parameter  $\delta$  is zero-mean, the objective function can be simplified as

$$\rho = \text{Min}_x C^T x + q^T(\hat{y}). \quad (3.16)$$

## 3.5.2 Piecewise linear decision rules

The approximation of LDR to the stochastic problem is often poor due to the recourse function of several problems has a behavior far from the linearity. In this context, a more accurate design to model the recourse function of a stochastic problem is through PLDR [46]. This method reduces the approximation gap to the stochastic problem by defining uncertainty through a piecewise linear function, however, the main disadvantage of this method is that the size of the problem increases significantly. A schematic representation of the different behavior between LDR and PLDR methods and respective approximation to the recourse function is illustrated in Figure 3.7.

It can be seen that the approximation to the recourse function by simple linear function generates a significant gap, since the value of  $x(\delta_i)$  increases linearly according to the increment of the uncertain parameter  $\delta_i$ . On the other hand, piecewise linear function considers two breakpoints, thereby reducing the gap to the recourse function. By

increasing the number of breakpoints it is expected a better approximation to the recourse function, however, the size of the problem also increases.

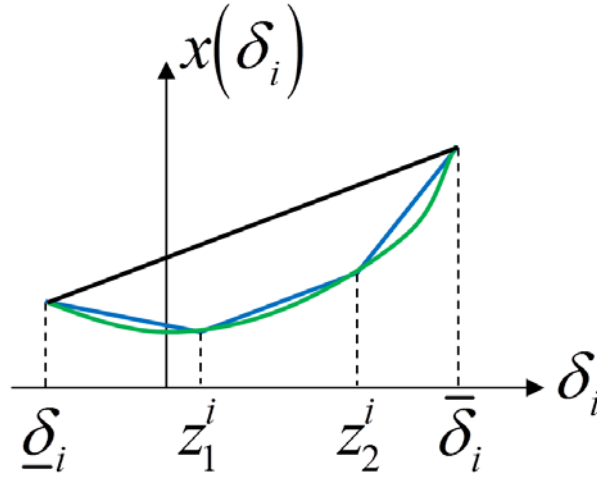

Figure 3.7 – Illustrative example of a natural recourse function (green), linear decision rules approximation (black) and piecewise linear decision rules approximation (blue) under the realization of the uncertain parameter.

In this context and with the aim of improving the approximation of the recourse function modelled in this thesis, this section provides the basic insights of the piecewise linear continuous decision rules with axial segmentation developed by [46]. This method requires the establishment of breakpoints  $z$  to model the piecewise function *a priori*. An improved technique of the PLDR (the PLDR with general segmentation) can optimally estimate these breakpoints, however the complexity of the problem increases even more. This technique is out of the scope of this thesis, thereby the interested readers are referred to [46].

The idea behind the PLDR with axial segmentation is to expand the sample space of the uncertain parameter  $\delta_i$  into  $r_i$  lines with  $r_i - 1$  breakpoints  $z_j^i$  for  $j \in \{1, \dots, r_i - 1\}$  and  $i \in \{1, \dots, k\}$

$$\underline{\delta}_i < z_1^i < \dots < z_{r_i-1}^i < \bar{\delta}_i, \quad \forall i \in \{2, \dots, k\} \quad (3.17)$$

where  $\underline{\delta}_i$  is the lower bound and  $\bar{\delta}_i$  the upper bound of  $\delta_i$ . Following the rational behind [46], one can introduce the lifted space  $\mathbb{R}^{k'}$  of the piecewise linear parameters  $\delta'_i \in \mathbb{R}^{r_i}$  in the lifted support  $G'$ , where  $\delta'_i \in G'$  and  $\delta' = (1, \delta_2'^T, \dots, \delta_k'^T)^T$ . Within this scope, the lifting operator  $L_{i,j}$  is constructed based on the breakpoints, as



### 3.5.2.1 Equality constraints reformulation

The equality constraint reformulation of the general stochastic problem takes its final form as

$$Tx + H\hat{y} = h, \quad (3.22a)$$

$$HK_i^y = 0, \quad \forall i \quad (3.22b)$$

### 3.5.2.2 Inequality constraints reformulation

The reformulation of the inequality constraints is similar to the one of Section 3.5.1.2, however, the matrix regarding the constraints of the minimization problem is based on the square matrix  $V$  that contains the information about the bounds and breakpoints of the piecewise linear function. Thus, inequality constraint (3.12e) of the second-stage problem is formulated as

$$\text{Min}_{\delta'} \left\{ \begin{array}{l} \sum_{i=1}^{r_i} K_i^y \delta_i', \\ \text{s.t. } \sum_{j=1}^r V_{i,(j+1)}' \delta_j' \geq -V_{i,1}' : \alpha_i, \quad \forall i \end{array} \right\} \geq -\hat{y}, \quad (3.23a)$$

where  $\alpha_i$  is the dual variable associated to the  $i$ -th inequality constraint. Following duality theory, the minimization problem is transformed to

$$\text{Max}_{\alpha} \left\{ \begin{array}{l} \sum_{i=1}^{r_i+1} -V_{i,1}' \alpha_i, \\ \text{s.t. } \sum_{i=1}^{r+1} V_{i,(j+1)}' \alpha_i = K_j^y \delta_j', \quad \forall j \\ \alpha_i \geq 0, \quad \forall i \end{array} \right\} \geq -\hat{y}, \quad (3.23b)$$

Then, the equivalent representation in a set of constraints follows

$$\sum_{i=1}^{r_i+1} -V_{i,1}' \alpha_i \geq -\hat{y}, \quad (3.24a)$$

$$\sum_{i=1}^{r+1} V_{i,(j+1)}' \alpha_i = K_j^y \delta_j', \quad \forall j \quad (3.24b)$$

$$\alpha_i \geq 0, \quad \forall i \quad (3.24c)$$

The remaining inequality constraints affected by the uncertainty must follow the same procedure as demonstrated above.

### 3.5.2.3 Objective function reformulation

The reformulation of the objective function based on the decision variables in form of (3.21) is given by



$$\text{Min}_x C^T x + q^T \left( \hat{y} + \sum_{i=1}^r K_i^y \mathbb{E}[\delta_i'] \right), \quad (3.25a)$$

where the expectation is considered for the uncertain parameter. The expectation for the PLDR is modeled based on the lifting operator matrix  $L_{i,j}$ , and the probability for each line segment  $\pi^r$

$$\mathbb{E}[\delta_i'] = \sum_{j=1}^{r+1} \left( \frac{L_{j(\underline{z}_i)} + L_{j(\bar{z}_i)}}{2} \right) \pi_i^r. \quad (3.25b)$$

The final form of the objective function is obtained through the replacement of (3.25b) in (3.25a).

# Renewable energy trading in energy and reserve markets

---

The existing electricity market models integrate RES in such a way that WPP can offer energy offers in the day-ahead market, accounting for their energy imbalances in the balancing market. However, the design and rules of electricity markets are not ready to absorb a large-scale penetration of RES into the system [62], and this is a major challenge. Additionally, the current developments of wind turbines technology allow WPP provide limited reserve services. In this context, another challenge comes from the interest of WPP in participating in the reserve market, taking advantage of improvements in technical controllability to provide different services.

To address these emerging challenges, this chapter presents strategic offering models for WPP that participate in both energy and reserve markets at the day-ahead and balancing stages. The goal is to maximize the expected revenue for WPP, allowing strategic offering in energy and reserve in day-ahead stage, while accounting for expected balancing costs from the balancing stage. The different methods and the results outlined in this chapter are presented in detail in Papers C, D and F. In Section 4.1 a potential market structure for wind offering in energy and reserve market is proposed, considering current market operation and new market mechanisms. The wind energy-only participation in the current electricity market, considering its analytical solution is shown in Section 0, as a special case of the new market structure. Then, in Section 4.3, current wind control policies for the split of available wind power in energy and reserve are discussed. These control strategies are essential in how the WPP behaves in the advanced market setup. The general revenue for this new market structure is stated in Section 4.4. Then, Section 4.5 presents the analytical derivation of the optimal offers of a strategic price-taker WPP, aiming to maximize expected energy and reserve markets revenue. Furthermore, advanced optimization methods based on stochastic programming and PLDR are performed in Section 4.6, giving different strategic options while reducing potential expected costs for WPP to participate in energy and reserve markets.

For the methodologies presented in the following sections, the market assumptions were built upon the current electricity market structure, similar to the market structure of Nord Pool. Furthermore, the balancing stage structure addressed in this work is based on the current Danish balancing market designation [17].

### 4.1 Energy and reserve offering market model

Under the new paradigm of WPP participation in both energy and reserve markets, current market rules need to be adapted. In fact, for WPP’s offers in the reserve market some considerations must be made. Firstly, the market rules should allow generators with uncertain and variable production offering in the reserve market. Secondly, this uncertain production must be taken into account in the market clearing mechanism, since uncertain production can reduce the proper levels of system reliability in a market previously designed with specific rules to guarantee system reliability. One way of constraining excess of uncertainty in reserve markets would be by settling penalties for WPP that do not provide contracted reserve levels. Within this scope, a model that allows WPP to participate in both energy and reserve markets, taking into account the penalties for energy and reserve deviations is proposed in Papers C, D and F and illustrated in Figure 4.1.

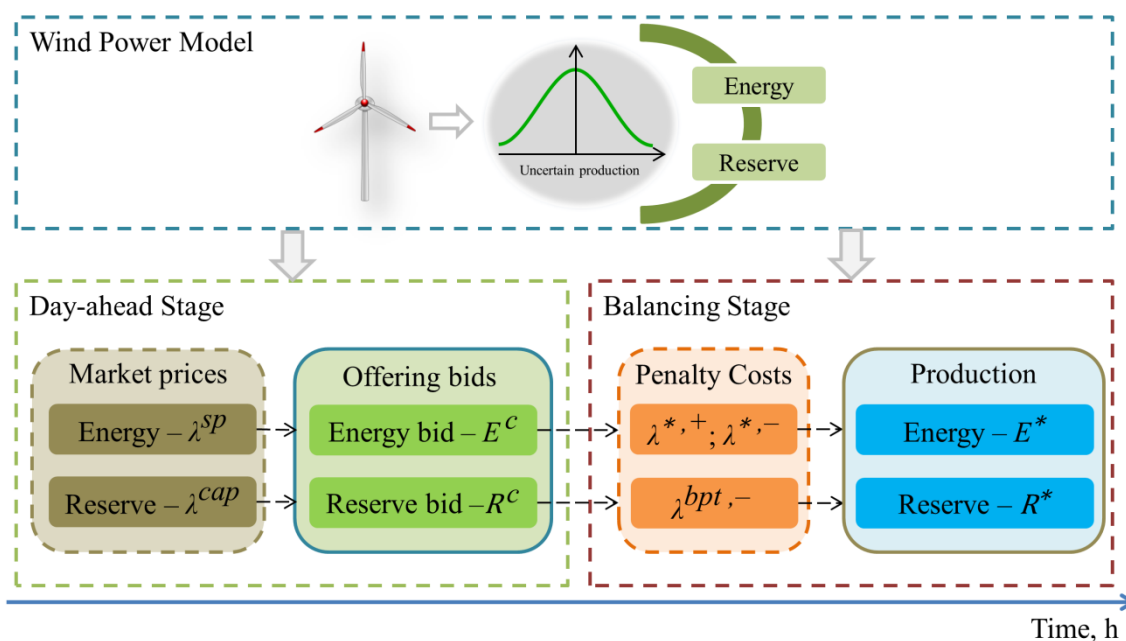

Figure 4.1 – Wind power participation model in the energy and reserve markets.

This model aims to facilitate the full integration of wind power into electricity markets, by considering that WPP participate in the energy and reserve markets. Thus, the WPP can split their expected available wind power both in energy and reserve bids in the day-ahead stage. Still, penalties for energy and reserve deviations at the balancing stage should be accounted for. Within this scope, some basic assumptions and new market

mechanisms allowing the development of optimization techniques to solve the problem must be stated.

#### **4.1.1 Price-taker behavior**

For a market with perfect competition, all market participants must accept prevailing prices in the market. That is, the offer of a market participant should not be able to influence the market equilibrium, assuming that they have a small market share. This conception is valid for WPP that represent an insignificant part of the transactions in the market. Although in future electricity markets, wind power will most likely play an important role in the market, it is expected that WPP of various capacities will participate in the markets. This assumption implies that the production of the WPP is independent of market prices and penalties.

#### **4.1.2 Expected mean prices**

Following the independence between power production and market prices from the price-taker behavior, and assuming that all prices and penalties enter linearly in the offering problem, stochastic prices can be replaced by expected mean prices. In more detail, given that wind power production and power imbalances are independent of energy prices and imbalance penalties, the full stochastic distribution of prices and penalties can be replaced by certainty equivalents (following certainty equivalent theory [63]), i.e., the expected mean prices and penalties.

#### **4.1.3 Probabilistic wind power forecast**

Wind power production is uncertain and time-varying due to wind being a natural and uncontrollable resource. Thus, obtaining a good forecast of the wind power is essential for WPP to offer their potential availability in the market. One way to account for wind uncertainty is through probabilistic wind forecasts. They summarize the potential wind power production by assigning a probability of occurrence. In the offering problem, distribution using wind power production is essential because it is the basis of different optimization techniques employed to determine the optimal offer participating in the market under uncertain production.

#### **4.1.4 Reserve balancing mechanism**

Once the proposed model allows for WPP to submit their offers in energy and reserve markets, contingencies for energy and reserve deviations should be thought of. Current electricity markets comprise of a balancing mechanism for energy deviations of market participants in the balancing stage. This mechanism allows market participants to correct their production/consumption imbalances through upward and downward penalties. In fact, WPP use this mechanism to correct their uncertain production from the day-ahead to the balancing stage. More precisely, energy offers submitted in the

day-ahead stage must account for potential imbalance (positive and negative deviations). Therefore, the penalties are asymmetric.

In the proposed market offering model, WPP can offer in both energy and reserve market products, thereby reserve penalties for reserve imbalances should be also considered. Furthermore, reserve offers submitted in the day-ahead stage only consider negative reserve deviations from the balancing stage, since the positive reserve deviation is not detrimental to the system's reliability. This occurs in cases of available reserve in balancing stage greater than the offered reserve in day-ahead stage.

#### **4.1.5 Taking advantage of better forecast information**

Despite these general characteristics, additional market improvements under this strategic market model for WPP were proposed and performed in Papers D and F. In more detail, the idea is to allow the share between energy and reserve at the balancing stage to be different of the energy and reserve share at the day-ahead stage (through control strategies explained in detail in Section 4.3). This idea is supported by the assumption of WPP to submit their operational schedule closer to the energy delivery.

Many electricity markets have different timeline for WPP submitting their offers and operational schedule, so bringing WPP offers close to delivery should be set up by the market and system operators, taking into account the inherent characteristics of the power system in that country/region. For example, in Denmark, WPP have to submit their operational schedule at the balancing stage (i.e., the special 5-minute production time series for delivery hour) 45 minutes before delivery, if WPP to participate in the regulation power market, otherwise 1 hour before delivery. Thus, if WPP could change their operational schedule of energy and reserve closer to the delivery (e.g., 30 minutes, 15 minutes or even 5 minutes before delivery), their power imbalance would be smaller leading to smaller imbalance costs. Similarly, several researchers have been arguing for gate closure delays of the day-ahead market for WPP to levels closer to the energy delivery [64], [65] (e.g., [64] proposes postponing the day-ahead closure time from 12:00 PM to 07:00 PM). This may reduce forecasting errors and related imbalances costs for WPP and the required reserve level in the regulation power market.

On the basis of this assumption, the objective is to allow WPP to change their operational schedule (share of energy and reserve) at the balancing stage according to their energy and reserve offers submitted at the day-ahead stage. The difference between the offers and the operational schedule will result in the power imbalances that are penalized in the balancing power market. Thus allowing the change of the energy and reserve share closer to the energy delivery will reduce expected balancing costs, thereby increasing the expected profit for the WPP.

Nevertheless, this idea is not available or even allowed in current electricity markets, since WPP may use it to postpone their decisions, i.e., use forecasts closer to the delivery to partially change the impact of their previous decisions. That is, according to

current market rules, decisions taken in the day-ahead stage cannot be changed in the balancing stage. In fact, previous decisions that create imbalances can only be offset by new adjustments in other market trading floors (e.g., intraday market).

## 4.2 Energy-only – analytical optimization

As a starting point, the simple case of offering in the energy-only market is considered. That is, in current electricity markets WPP only offer in the energy market. One way of solving this problem is through analytical optimization, as suggested in [66]. The analytical optimization takes advantage of analytical equations and functions to solve the problem. One typical problem that is solved with analytical optimization is the newsvendor problem [67]. This type of problem appeared initially in [68]. This problem concerns a newspaper vendor who must decide how many copies of the newspaper to stock in the face of uncertain demand and knowing that unsold copies will be worthless at the end of the day.

Let us define the newsvendor problem assuming  $x$  as the random variable with probability distribution function  $f(x)$  representing the demand of newspapers.  $\lambda^-$  is the unit underage cost, i.e., the unit newspaper cost for being short – the cost for having less newspapers than the demand requires.  $\lambda^+$  is the unit overage cost, i.e., the unit newspaper cost for being long – the cost of having more newspapers than the demand requires.  $Q$  is the ordering quantity decision variable, i.e., the number of units stocked. The aim of the newsvendor is to maximize his expected profit, which mathematically can be seen as the minimization of the total expected costs  $Z$ , which is modeled as:

$$Z = \lambda^+ \int_0^Q (Q - x) f(x) dx + \lambda^- \int_Q^\infty (x - Q) f(x) dx. \quad (4.1)$$

The Leibniz rule is then used to analytically solve the problem. The Leibniz rule, for an arbitrary function  $f$ , parameters  $\theta$ , and integration bounds  $a$  and  $b$ , states that

$$\begin{aligned} \frac{\partial}{\partial \theta} \left( \int_{a(\theta)}^{b(\theta)} f(x, \theta) dx \right) &= \int_0^1 \partial_\theta f(x, \theta) dx + f(b(\theta), \theta) b'(\theta) \\ &\quad - f(a(\theta), \theta) a'(\theta) \end{aligned} \quad (4.2)$$

In this way, the derivative of (4.1) with respect to  $Q$  is given by

$$\frac{\partial Z}{\partial Q} = \lambda^+ \int_0^Q f(x) dx + \lambda^- \int_Q^\infty -f(x) dx. \quad (4.3)$$

The optimal level of stock is obtained by equating the derivative in (4.3) to 0, then yielding an optimal quantile of the predictive cumulative distribution function  $F$  for the newspapers demand

$$Q = F^{-1}\left(\frac{\lambda^-}{\lambda^+ + \lambda^-}\right). \quad (4.4)$$

Similarly, in electricity markets the same concept can be applied in order to calculate WPP's optimal bid in the energy-only market [66]. In this context,  $Q$  stands for the optimal bid of wind power to submit in the energy-only market;  $F$  stands for the cumulative distribution function of wind power generation;  $\lambda^+$  represents the energy unit cost for positive deviation, i.e., when the wind power delivered in the balancing is higher than the contracted in the day-ahead market; and  $\lambda^-$  is the energy unit cost for negative deviation, i.e., when the wind power contracted in day-ahead is higher than the energy delivered in the real-time. Thus, analytical optimization can be of most interest for solving problems such as the optimal offering problem for wind power plants in electricity markets.

Further in this chapter, an extension of the previous analytical optimization has been applied on a new offering problem, where the WPP can participate in both energy and reserve markets considering that there is direct correlation of the wind power to provide both market products. This model has been fully investigated in Paper C considering different control strategies for the split of available wind power to offer in the energy and reserve markets.

For an in-deep discussion on optimal allocation of different products with distinct uncertain distributions and considering multi-constraints, the interested reader is referred to [69], [70].

### 4.3 Control policies for wind power

Current wind power plants have the ability to control the provision of energy and reserve in different ways. In fact, such control policies have been required by system operators to ensure stability and reliability of the power system under high penetration of wind power. System operators have been updating grid-codes with new active power control methodologies for WPP. The aim is to allow the controlled curtailment of wind power to reduce congestion or balancing the power system when there is a considerable excess of power production in the system. Additionally, such control policies may also be used for reserve provision, i.e., wind farms may retain part of the available wind power to provide as upward reserve. Within this scope, different methods for active power control of wind power for providing energy and reserve can be found in literature [71]–[74].

In this thesis, the controllability of proportional and constant control strategies (proposed in [71] and illustrated in Figure 4.2) has been studied for optimal offering of wind power in the energy and reserve markets. The total available wind power production is given by  $Q$  (blue line), while the energy share is represented by  $E^c$  (red line). The reserve share  $R^c$  is defined by the area between the blue and red curve.

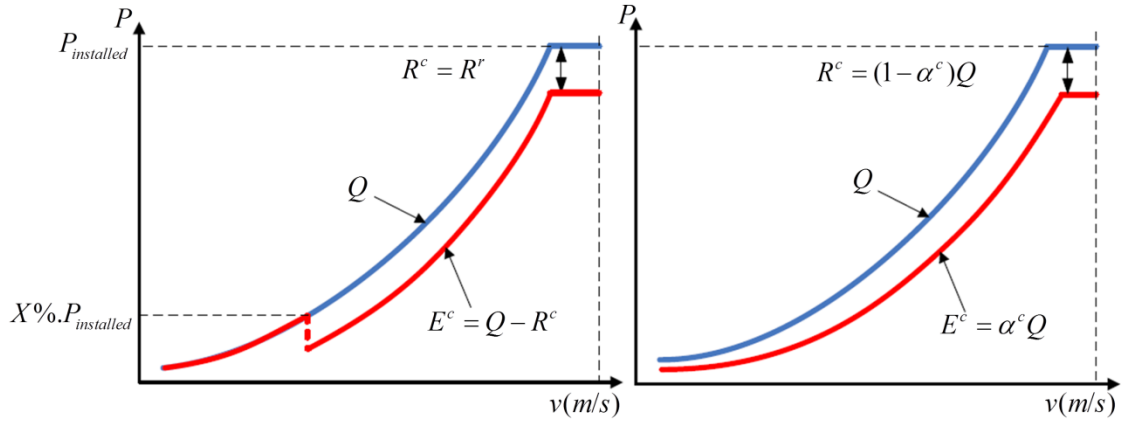

Figure 4.2 – Constant (left) and proportional (right) wind control strategies for split available wind power production in energy and reserve. Adapted from [71].

Constant wind control consists of a constant curtailment of power from the expected available wind power production. This constant curtailment is only performed in cases of available wind power exceeding a certain level of wind power. This curtailment is allocated as reserve to submit in the reserve market. The remaining available wind power is considered for offering in the energy market.

Proportional wind control is based on the proportional split of available wind power in energy and reserve through  $\alpha^c$ .  $\alpha^c$  is the proportional share parameter that splits the available wind power into energy and reserve assuming a value between 0 and 1.

#### 4.4 General formulation of market revenues

An important aspect of the new market model, including assumptions and properties discussed in Section 4.1 to 4.3 is the calculation of market revenue for WPP. In general, market revenues for a WPP offering in energy and reserve markets in the day-ahead, while accounting for potential penalties in the balancing stage is expressed as

$$Rev = \lambda^{sp} E^* + \lambda^{cap} R^c - T^* - O^* \quad (4.5)$$

where  $\lambda^{sp}$  is the expected spot price,  $E^*$  is the amount of expected delivered energy,  $\lambda^{cap}$  is the expected capacity price for contracting reserve,  $R^c$  is the expected contracted level of power reserve in day-ahead stage,  $T^*$  are the expected costs for energy deviations in the balancing stage and  $O^*$  is the expected penalty cost from failing to provide the scheduled reserve.

The aforementioned assumptions concern that the WPP behaves as a price-taker. This means that WPP production is independent of market prices and penalties. From this, it can be assumed that the formulation depends only on the expected mean prices and penalties, rather than the full distribution of prices and penalties, as explained in [63], [75]. Thus, the expected costs for energy deviations in the balancing stage are defined as



$$T^* = \begin{cases} \lambda^{*,+} (E^* - E^c), & E^* - E^c \geq 0 \\ -\lambda^{*,-} (E^* - E^c), & E^* - E^c < 0 \end{cases} \quad (4.6)$$

where  $(E^* - E^c)$  is the energy deviation between the energy delivered  $E^*$  in the balancing stage and the energy contracted (offered)  $E^c$  in the day-ahead stage. The parameters  $\lambda^{*,+}$  and  $\lambda^{*,-}$  are the balancing unit costs for positive and negative energy deviations, respectively. Likewise, balancing unit costs are defined as

$$\begin{aligned} \lambda^{*,+} &= \lambda^{sp} - \lambda^{c,+} \\ \lambda^{*,-} &= \lambda^{c,-} - \lambda^{sp} \end{aligned} \quad (4.7)$$

where  $\lambda^{c,+}$  is the unit down-regulation price for being long, while  $\lambda^{c,-}$  is the up-regulation price for being short. Furthermore, following the market settlement characteristics of the Danish TSO, the two-price settlement rule for mapping the balancing costs for energy deviations is assumed [66]. For an extensive explanation and comparison on the influence of the one-price and two-price settlement rule in electricity markets with high penetration of renewables, the interested reader is referred to [3]. Thus, the two-price settlement rules establish that in cases of negative system imbalance (energy surplus – need for downward regulation), the prices behaves as

$$\begin{aligned} \lambda^{c,+} &\leq \lambda^{sp} \\ \lambda^{c,-} &= \lambda^{sp} \end{aligned} \quad (4.8)$$

On the other hand, in cases of positive system imbalance (energy deficit – need of upward regulation), sustains that

$$\begin{aligned} \lambda^{c,+} &= \lambda^{sp} \\ \lambda^{c,-} &\geq \lambda^{sp} \end{aligned} \quad (4.9)$$

Otherwise in cases of no imbalance, both  $\lambda^{c,+}$  and  $\lambda^{c,-}$  are equal to the spot price  $\lambda^{sp}$ . Similar assumptions to account with the reserve imbalance in the balancing stage are performed. Thus, the expected penalty for not providing the reserve is modeled as

$$O^* = \begin{cases} \lambda^{bpt,+} (R^* - R^c), & R^* - R^c \geq 0 \\ -\lambda^{bpt,-} (R^* - R^c), & R^* - R^c < 0 \end{cases} \quad (4.10)$$

where  $(R^* - R^c)$  is the reserve power imbalance between the realized level of reserve  $R^*$  in the balancing stage and the reserve contracted (offered)  $R^c$  in day-ahead stage.  $\lambda^{bpt,+}$  is the unit penalty for generating more power than the contracted (surplus). In contrast,  $\lambda^{bpt,-}$  is the unit penalty cost when WPP has less available power in the balancing stage than contracted in the day-ahead stage. These hold that

$$\begin{aligned}\lambda^{bpt,+} &= \lambda^{cap} - \lambda^{pt,+} \\ \lambda^{bpt,-} &= \lambda^{pt,-} - \lambda^{cap}\end{aligned}\tag{4.11}$$

hence  $\lambda^{bpt,+}=0$  since (extra) positive reserve is not detrimental to the system's reliability. However, when this positive reserve deviation occurs, it can be comprehended as a loss opportunity cost from the WPP's standpoint. On the other hand,  $\lambda^{pt,-}$  is the penalty for negative reserve imbalance, weighted by the probability that reserve is needed.

## 4.5 Analytical approach

This section focuses on the characterization and analytical derivation of optimal offers for WPP participation in energy and reserve markets, detailed in Paper C. Naturally, the optimal bids heavily depend on the prices and penalties of the energy and reserve markets. Under the current electricity market regulatory framework, the energy price is normally higher than the reserve price, so there is no incentive for WPP to participate in the reserve market [76]. In a market a structure like the one presented in this thesis, for WPP to participate in reserve markets, proper incentives should be ensured by market operators, i.e., they should provide appropriate price signals to encourage WPP to offer their flexibility [5].

Occasionally, three distinct levels of operation may occur and influence the decision-making process of WPP. In normal operation, it is assumed that the reserve market price is higher than the energy price ( $\lambda^{cap} \geq \lambda^{sp}$ ), and that the reserve penalty for reserve deviations is greater than the energy penalty for energy deviations ( $\lambda^{bpt,-} \geq \lambda^{*, -}$ ). The energy and reserve penalty ratio follows the normal hierarchy of power system, so it makes sense that failing to provide reserve is worse than not providing the energy promised in the energy market. The other two levels of operation, occurs when there is an economic incentive (price and penalties relationship) to participate in a single market, either energy or reserve. This section will focuses on the normal operation, i.e., the most logical relationship between energy and reserve prices and penalties that encourage WPP offering in both energy and reserve markets. Detailed offering under different levels of operation can be found in Paper C.

### 4.5.1 Optimal offering under constant control

The optimal offer considering the constant control under normal relation between prices and penalties for energy and reserve is derived analytically based on a process thoroughly presented in Paper C and outlined in Section 4.2.

$$Q = F^{-1}\left(\frac{\lambda^{*, -}}{\lambda^{*, +} + \lambda^{*, -}}\right),\tag{4.12}$$

$$R^c = F^{-1} \left( \frac{\lambda^{cap} - \lambda^{sp}}{\lambda^{bpt,-} - \lambda^{*,-} + \lambda^{cap} - \lambda^{sp}} \right). \quad (4.13)$$

The optimal bid (4.12) represents the total power bid (energy and reserve) while (4.13) represents the optimal bid for submitting in the reserve market. The optimal bid for the energy market  $E^c$  is given by the subtraction of the total power bid  $Q$  and reserve bid  $R^c$ .

#### 4.5.2 Optimal offering under proportional control

Under the proportional control of WPP, the optimal bid for the energy and reserve markets is given by

$$Q = F^{-1} \left( \frac{\lambda^{*,+} \alpha^c + \lambda^{cap} (1 - \alpha^c)}{(\lambda^{*,+} + \lambda^{*,-}) \alpha^c + (\lambda^{bpt,+} + \lambda^{cap}) (1 - \alpha^c)} \right). \quad (4.14)$$

The above expression is valid only for the fixed assumption, whereby the share between energy and reserve in day-ahead stage have the same share in the balancing stage ( $\alpha^c = \alpha^*$ ). Naturally, the analytical bid will depend on the share parameter  $\alpha^c$ . Following, Paper C, non-linearity of affine functions of the proportional control strategy infers that bids will take place in energy or reserve market, but not in both markets, simultaneously. In this context, the relationship between energy and reserve penalties is crucial to allocate the expected available wind power in energy (in case of  $\lambda^{bpt,-} \geq \lambda^{*,-}$ ) or reserve (in case of  $\lambda^{*,+} \geq \lambda^{bpt,+}$ ).

#### 4.5.3 Optimal energy and reserve bids

The analytical expressions outlined in the previous sections for the WPP's optimal bid in energy and reserve are applied in a case study, comparing the behavior and economic performance of proportional and constant control strategies. The case study is based on real-data and considers a 15 MW wind power plant participating in the Nord Pool market. Further details on the data can be found in Paper C.

Figure 4.3 illustrates the different behavior of constant and proportional control strategies. It can be seen that in most of the periods, constant control strategy splits the available wind power for participation in both markets. Furthermore, proportional strategy offers all the available power to a single market. From an economic point of view, both control strategies present similar trends, however, proportional control provides higher expected revenues over time. On average, proportional control improves the expected revenue of the WPP relative to the constant control by about 8%. This results from the different intrinsic characteristics of each control strategy, yielding different behavior in the market. Such conclusions can only be made in the context of the specific case study presented in Paper C.

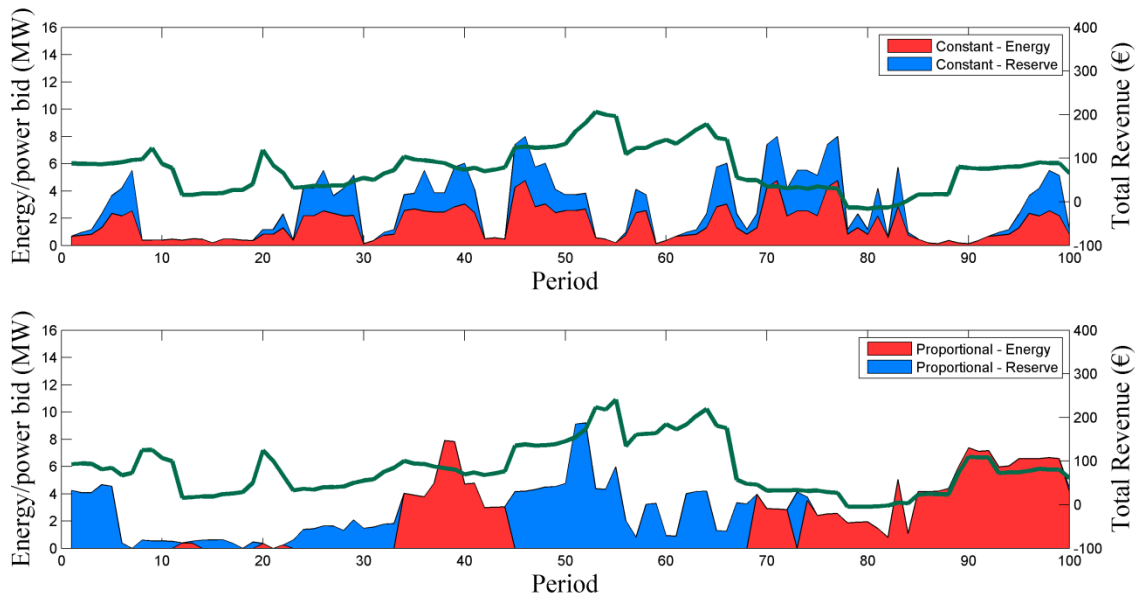

Figure 4.3 – Constant (top) and proportional (bottom) control strategies over the time, under analytical optimal offering.

## 4.6 Optimization techniques

Papers D and F address the optimal offering of WPP in energy and reserve markets considering different assumptions and techniques to improve the expected market revenues, as well as the strategic bidding of WPPs. This section summarizes optimization techniques that can derive the optimal offer of wind in energy and reserve markets, considering the proportional control strategy. Section 4.6.1, describes the fully flexible stochastic approach that allows different share of energy and reserve between day-ahead and balancing stages. Then, the fixed share of energy and reserve in both stages is exemplified, in Section 4.6.2. The fixed approach considers the same assumptions used in Section 4.5. Section 4.6.3 addresses a hybrid approach between the fixed and flexible approach. McCormick's relaxation is used to model the convex part of bilinear constraints used in the fixed approach. Additionally, a coefficient to control the influence of the balancing stage information in day-ahead decisions is described. Section 4.6.4 presents the offering problem modelled by PLDR. This method relaxes the assumptions of a discrete distribution for the uncertain parameter in contrast to stochastic programming. A brief evaluation and comparison of the aforementioned approaches, considering their intrinsic behavior and market revenues, is exemplified in Section 4.6.5.

### 4.6.1 Flexible stochastic approach

The full flexible stochastic approach relies on the assumption of different share parameter to split the available wind power into energy and reserve, between day-ahead and balancing stages (addressed in Paper D and F). In fact, this mechanism allows WPP to use forecasts of their production closer to the real-time, in the day-ahead decision-

making process. The optimization problem is formulated as a two-stage stochastic programming (as explained in Section 3.3), and is presented as follows

$$\text{Max } \lambda^{cap} R^c + \sum_{w \in \Omega} \pi_w \left[ \lambda^{sp} E_w^* - \lambda^{*,+} \Delta E_w^+ - \lambda^{*,-} \Delta E_w^- - \lambda^{bpt,-} \Delta R_w^- \right] \quad (4.15a)$$

$$\text{s.t. } P^{Min} \leq Q^c \leq P^{Max}, \quad (4.15b)$$

$$E^c + R^c = Q^c, \quad (4.15c)$$

$$E_w^* + R_w^* = Q_w^*, \quad \forall w \in \Omega \quad (4.15d)$$

$$E^c - E_w^* = \Delta E_w^- - \Delta E_w^+, \quad \forall w \in \Omega \quad (4.15e)$$

$$R^c - R_w^* \leq \Delta R_w^-, \quad \forall w \in \Omega \quad (4.15f)$$

where  $\Delta E^+$  is the surplus of energy incurred by the WPP,  $\Delta E^-$  is the deficit of energy incurred by the WPP,  $\Delta R^-$  is the deficit of reserve incurred by the producer,  $\pi_w$  is the probability in each scenario  $w$ ,  $P^{Min}$  and  $P^{Max}$  are the lower and upper bounds of the total power bid in the day-ahead stage, respectively. With this market mechanism, the WPP can adjust the share of energy and reserve in the balancing stage considering the expected power production in each scenario  $w$ .

#### 4.6.2 Fixed stochastic approach

In contrast, the fixed stochastic approach considers the same share of energy and reserve in both trading floors. Thus, the mathematical formulation of the fixed stochastic formulation considers

$$E^c = \alpha^c Q^c, \quad (4.16a)$$

$$R^c = (1 - \alpha^c) Q^c, \quad (4.16b)$$

$$E_w^* = \alpha_w^* Q_w^*, \quad \forall w \in \Omega \quad (4.16c)$$

$$R_w^* = (1 - \alpha_w^*) Q_w^*, \quad \forall w \in \Omega \quad (4.16d)$$

$$\alpha_w^* = \alpha^c, \quad \forall w \in \Omega \quad (4.16e)$$

where the energy and reserve offered in the day-ahead market is determined in (4.16a) and (4.16b), respectively. Both constraints represent the proportional control strategy and form a system of bilinear equations which is non-convex. The non-convexity of both equations makes the problem more complex, however, feasible with suitable solvers. The formulation is completed with equations (4.15a), (4.15b), (4.15e) and (4.15f) of the previous model.

### 4.6.3 Stochastic approach under McCormick relaxation

In the view of turning convex the previous problem, convex relaxation methods can be performed. McCormick's relaxation is a relaxation method that has the ability to perform a tight approximation gap of the bilinear system of constraints, as explained in Section 3.2 and implemented in Paper F. Besides that, a coefficient to limit the influence of the balancing stage information in the day-ahead decision-making process is included. Within this scope, the WPP gains controllability of the influence of information near the real-time in the day-ahead decisions. Thus, the WPP wind offering problem is reformulated as

$$E^c \geq P^{Min} \alpha_w^*, \quad \forall w \in \Omega \quad (4.17a)$$

$$E^c \leq P^{Min} \alpha_w^* + Q^c - P^{Min}, \quad \forall w \in \Omega \quad (4.17b)$$

$$E^c \leq \alpha_w^* P^{Max}, \quad \forall w \in \Omega \quad (4.17c)$$

$$E^c \geq \alpha_w^* P^{Max} + Q^c - P^{Max}, \quad \forall w \in \Omega \quad (4.17d)$$

$$-\varepsilon \leq \alpha^c - \alpha_w^* \leq \varepsilon, \quad \forall w \in \Omega \quad (4.17e)$$

where  $\varepsilon$  is a coefficient that defines the difference between the share parameter in both day-ahead and balancing stages. The coefficient varies between 0 and 1, thus influencing the behavior of the split between energy and reserve. If  $\varepsilon$  is closer to 0, the behavior of this approach will be closer to the fixed stochastic approach. On the opposite, when  $\varepsilon$  is closer to 1 this approach behaves similarly to the flexible stochastic approach. The formulation is completed by including equations (4.15a), (4.15c) to (4.15f) and (4.16c), representing the objective function and the general constraints of the problem.

### 4.6.4 Piecewise linear decision rules with axial segmentation

Linear Decision Rules (LDR) is a different way of modeling the recourse function of a two-stage stochastic problem. In fact, it linearizes the uncertainty of the stochastic problem, through upper and lower tractable limits of the uncertainty interval. Thus, this model does not require discrete distribution of the uncertain parameter in contrast to stochastic programming. However, the linear approximation of the uncertain parameter can lead to a rough approximation of the natural distribution of the uncertain parameter. Hence, the PLDR can be modeled, reducing the approximation gap for the natural uncertain distribution, but at the cost of increasing the complexity of the formulation. Based on Section 3.5.2 and Paper F, the equivalent PLDR formulation of the WPP offering problem in the energy and reserve markets under the flexible stochastic approach is given by

$$\begin{aligned}
\text{Max } & \lambda^{cap} R^c + \lambda^{sp} \left( \hat{E}^* + \sum_{i=1}^{r_i} \sum_{j=1}^{r+1} K_i^E \left( \frac{L_{j(\underline{z}_i)} + L_{j(\bar{z}_i)}}{2} \right) \pi_i^r \right) \\
& - \lambda^{*,+} \left( \Delta \hat{E}^+ + \sum_{i=1}^{r_i} \sum_{j=1}^{r+1} K_i^{\Delta E^+} \left( \frac{L_{j(\underline{z}_i)} + L_{j(\bar{z}_i)}}{2} \right) \pi_i^r \right) \\
& - \lambda^{*,-} \left( \Delta \hat{E}^- + \sum_{i=1}^{r_i} \sum_{j=1}^{r+1} K_i^{\Delta E^-} \left( \frac{L_{j(\underline{z}_i)} + L_{j(\bar{z}_i)}}{2} \right) \pi_i^r \right) \\
& - \lambda^{bpt,-} \left( \Delta \hat{R}^- + \sum_{i=1}^{r_i} \sum_{j=1}^{r+1} K_i^{\Delta R^-} \left( \frac{L_{j(\underline{z}_i)} + L_{j(\bar{z}_i)}}{2} \right) \pi_i^r \right)
\end{aligned} \tag{4.18a}$$

$$\text{s.t. } \hat{E}^* + \hat{R}^* = \hat{Q}^*, \tag{4.18b}$$

$$K_i^E + K_i^R = K_i^Q, \quad \forall i \tag{4.18c}$$

$$E^c - \hat{E}^* = \Delta \hat{E}^- - \Delta \hat{E}^+, \tag{4.18d}$$

$$-K_i^E = K_i^{\Delta E^-} - K_i^{\Delta E^+}, \quad \forall i \tag{4.18e}$$

$$\sum_{i=1}^{r+1} -V_{i,1}' \mu_i \geq R^c - \hat{R}^* - \Delta \hat{R}^-, \tag{4.18f}$$

$$\sum_{i=1}^{r+1} V_{i,(j+1)}' \mu_i = K_j^R + K_j^{\Delta R^-}, \quad \forall j \tag{4.18g}$$

$$\mu_i \geq 0, \quad \forall i \tag{4.18h}$$

where the recasting of the objective function under PLDR is presented in (4.18a). The constraints (4.18b) and (4.18c) represent the equality constraint reformulation of constraint (4.15d) of the flexible approach. Similar reformulation of constraints (4.15e) is given by (4.18d) and (4.18e). Additionally, the reformulation of the inequality constraints of the recourse problem in the flexible approach (4.15f) is given by the system of constraints from (4.18f) to (4.18g). Under this system of constraints,  $\mu$  is the dual variable of the inequality constraint, and  $V$  a square matrix with information about the characteristics of the piecewise linear function. A similar recast for all positive decision variables of the recourse problem are performed as explained in the Section 3.5.2. The model is completed by including the first stage constraints (4.15b) and (4.15c) of the flexible approach.

#### 4.6.5 Optimal energy and reserve bids

All the optimization methods outlined above were tested and performed under different cases studies in Papers D and F, allowing a proper analysis of the impact of each method on the energy and reserve split. Below, the results of an illustrative example to test all the optimization methods are shown. Let a 12 MW installed wind power plant

with a set of 100 wind power scenarios, with a lower bound of 3 MW for offering in the market. Additionally, a set of expected prices and penalties are illustrated in Table 1, encouraging WPP to distribute expected wind power to the energy and reserve markets. Besides, the set of breakpoints defined for the PLDR method corresponds to the 25%, 50% and 75% quantile of the wind power distribution.

Table 1 – Prices and unit penalty costs for energy and reserve.

Energy	Price (€MWh)	Reserve	Price(€MW)
$\lambda^{sp}$	40	$\lambda^{cap}$	41
$\lambda^{c,+}$	30	$\lambda^{bpt,+}$	0
$\lambda^{c,-}$	50	$\lambda^{pt,-}$	96

Each optimization method was tested under the above conditions, revealing its behavior of splitting the available wind power in energy and reserve, as well as its economic performance. In fact, Figure 4.4 illustrates the participation of each technique in the energy market, i.e., the amount of energy offered in the day-ahead stage  $E^c$ , and its expected share of delivered energy in the balancing stage  $E^*$ .

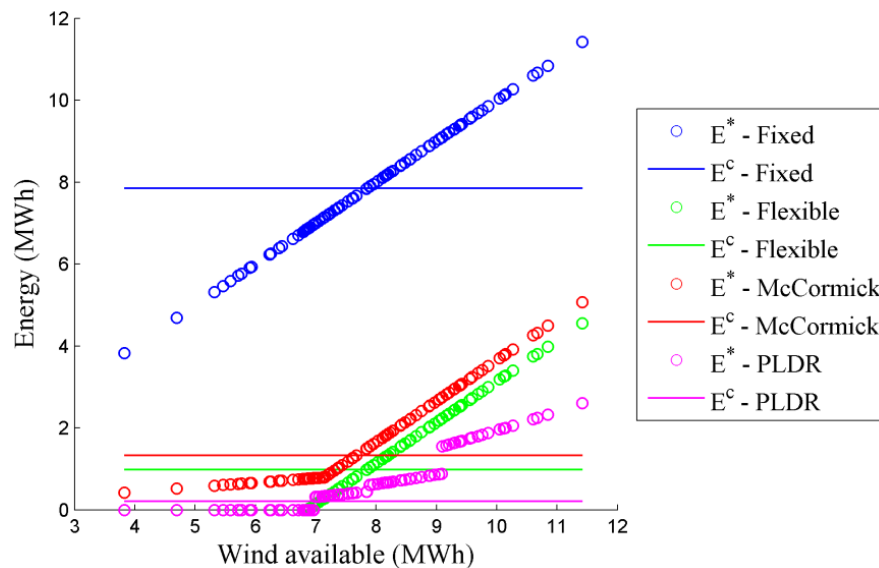

Figure 4.4 – Behavior of energy offered ( $E^c$ ) and delivered ( $E^*$ ) in the market for fixed, flexible, McCormick with  $\varepsilon=1$  and piecewise linear decision rules methods.

The performance of the fixed approach incites all expected available wind power to be submitted to the energy market, thereby reducing the risk of high penalties in the reserve market. In contrast, flexible, McCormick and PLDR approaches offer similar bids in the energy market, providing small amounts of expected available power and taking advantage of the expected higher revenue from the reserve market. It is noteworthy that the expected energy delivered depends on the x-axis, i.e., the expected



available wind power in the balancing stage. Predictably, the expected delivered energy from PLDR, follows piecewise linear function considering the three breakpoints based on the wind power distribution.

In contrast, the bids in the reserve market (illustrated in Figure 4.5) follow a different trend from the energy market. In fact, there is no fixed approach participation, since this method does not take advantage of better forecast information closer to real-time to influence its day-ahead decisions, thus avoiding offering in the reserve market, unless the margin between offering in energy and reserve is significantly higher. On the contrary, the remaining approaches try to increase the expected revenues from the reserve market even knowing that reserve penalties for not providing the offered reserve are significantly higher comparing to energy penalties in the energy market.

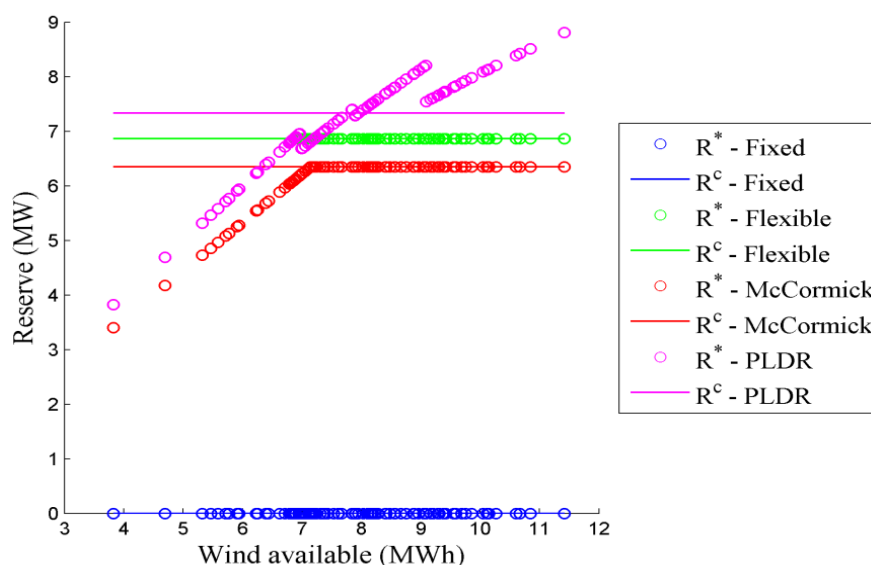

Figure 4.5 – Behavior of reserve offered ( $R^c$ ) and deployed ( $R^*$ ) in the market for fixed, flexible, McCormick with  $\varepsilon=1$  and piecewise linear decision rules methods.

Taking Figure 4.4 and Figure 4.5 for analysis, flexible, McCormick and PLDR approaches fully allocate the available wind power (only to lower levels of available wind power, i.e., up to 7 MWh) to the reserve market. This occurs until the reserve offered in the day-ahead stage is covered by the actual available wind power, thus minimizing the impact of the reserve penalty ( $\lambda^{bpt,-}$ ) in the balancing stage, which is significantly higher than the energy penalty  $\lambda^{*,-}$ . On the other hand, for available wind power levels (in the balancing stage) greater than the reserve offered in the day-ahead stage, both flexible and McCormick approaches deploy the reserve level offered in the day-ahead stage. Thus, the remaining available wind power is allocated to produce energy. Even knowing that there is a penalty for energy surplus, flexible and McCormick approaches produces it, since the spot price for energy production is greater than the penalty on energy surplus ( $\lambda^{sp} \geq \lambda^{*,+}$ ), thereby creating an incentive for WPP delivering the remaining available power as energy. Similar behavior is shown for

PLDR, however, PLDR allocates more wind available power at the balancing stage than required to cover the offered reserve, thus inflecting a loss of opportunity cost in order to ensure such robustness.

Economically speaking, the flexible approach is the one that ensures higher expected revenues, followed by the McCormick, PLDR and fixed approaches. Although, McCormick with  $\varepsilon=1$  approach presents behavior close to the flexible approach, different values of  $\varepsilon$  (e.g., 0) leads to behavior and results closer to the fixed approach. The controllability of using better forecast information close to real-time is deeply discussed in Paper F.

## 4.7 Conclusions

Throughout the continuous penetration of renewables in power systems, renewables production has been gaining importance and will play a key role in the electricity markets in the not-so-distant future. Thus, renewables producers (namely WPP) are willing to offer their available production to the energy market and, more recently, to the reserve market as well.

The models presented in this thesis address the optimal offering of WPP in energy and reserve markets under expected characteristics of future electricity markets. The developed methods result from the consequent transformation of power systems, where WPP are able to provide energy and reserve services to the market, accounting for their intrinsic characteristics regarding their uncertain and variable production.

This section presents an overview of the characteristics of all proposed methods for solving the wind offering problem in the energy and reserve markets. Table 2 presents a summary of the characteristics and an evaluation of the performance of each method.

Table 2 – Summary of the proposed methods characteristics for solving the wind offering problem in the energy and reserve markets.

Method	Analytical	Fixed	Flexible	McCormick	PLDR
Constant wind control	Yes	No	No	No	No
Proportional wind control	Yes	Yes	Yes	Yes	Yes
Ability of using better forecast information	No	No	Yes	Yes	Yes
Controllability of better forecast information	n/a	n/a	+	+++	++
Simultaneous energy and reserve offering	+	+	++	++	+++
Formulation complexity	++	+	+	++	+++
Economic performance	+	+	+++	++	+

\* n/a – not applicable

One of the characteristic that all methods support is the use of proportional wind control. This control has been thoroughly studied in all methods, since it has been mathematically proven from the analytical approach that proportional wind control obtains higher expected market revenues for the WPP than the constant wind control (for more details, see Paper C). Then, to the proportional wind control, a market mechanism that allows different shares of energy and reserve between day-ahead and balancing market can be implemented, thus improving the performance of optimization techniques. This is true because of the ability to use better forecast information of the wind power production when it is close to real-time. Under this market and wind controller characteristics, the flexible approach is the one that gets higher market revenues, followed by McCormick and PLDR approaches, respectively. Besides, the flexible approach also offers in both energy and reserve markets simultaneously, as well as is the best method in terms of formulation complexity (the “+” symbol in characteristic of formulation complexity stands for higher complexity, e.g., methods with “++” are more complex than methods with a single “+”). However, a drawback of the flexible approach to the PLDR and especially to McCormick is the lack of flexibility to control the influence of forecast information closer to real-time. The ability of the McCormick approach to control the influence of the information (through a coefficient) can be used to control the risk in some extent. Similarly, PLDR can be improved depending on the number and value of the breakpoints to approximate the piecewise function to the natural recourse function.

Nonetheless, to ensure the participation of the WPP in the energy and reserve markets, a set of prices and penalties are assumed following a specific rationale. That is, the behavior of WPP depends heavily on expected prices and penalties for energy and reserve. Under normal operating conditions (where WWPs split available power for energy and reserve), the expected reserve market price must be higher than the energy price ( $\lambda^{cap} \geq \lambda^{sp}$ ), and the reserve penalty for negative deviations greater than the energy penalty ( $\lambda^{bpt,-} \geq \lambda^{*,-}$ ). Otherwise, in some operational situations, prices and penalties may have different ratio, which leads to different offering strategies in the market. For instance, in cases where the reserve market price is lower than the energy price ( $\lambda^{cap} \leq \lambda^{sp}$ ) and reserve penalty for negative deviations is greater than the energy penalty ( $\lambda^{bpt,-} \geq \lambda^{*,-}$ ) the WPP will offer all available power to the energy market. In contrast, in cases where the reserve market price is greater than the energy price ( $\lambda^{cap} \geq \lambda^{sp}$ ) and reserve penalty for negative deviations is lower than the energy penalty ( $\lambda^{bpt,-} \leq \lambda^{*,-}$ ) the WPP will offer only in the reserve market. In this context, it is imperative that the market operator provides adequate economic signals to guarantee that WPP offer in both energy and reserve markets.

# Renewables flexibility from the market and system operation perspective

---

The continuous integration of renewables in power systems (incentivized by many governments with recent targets of 100% renewables by 2050) is awakening market and system operators to assess and change their actual way of operating electricity markets and power systems at different levels. Indeed, future participation of renewables in energy and reserves markets create some concerns for the market operator in order to maintain low levels of energy deviations and to provide adequate economic signals to market participants. Furthermore, DER such as RES are challenging the current operation rules of the distribution system. DER will bring more uncertainty to the distribution grid, but also more flexibility to assist the DSO in the management of the distribution network. Thus, a local flexibility market has been discussed allowing DSOs to contract sufficient flexibility to carry out an adequate network management. In addition, the costs for network management under such circumstances must be covered by both, consumers and DER. In this context, new methods and studies for assessing such enumerated challenges should be developed.

This chapter assesses renewable participation in electricity markets and distribution grids, taking into account the market and system operator perspective. The assessment of renewable offering in electricity markets from the market operator perspective is addressed and detailed in Paper B. In more detail, Section 5.1 assesses the energy market equilibrium by considering new offering strategies for WPP in the energy and reserve markets. Furthermore, a novel operating model for procurement of flexibility from DER at distribution level is presented in Section 5.2 and detailed in Paper E. Therefore, a preventive distribution grid management for DSOs, operating future distribution grids with high levels renewable sources is performed under a robust optimization model ensuring a proper level of system reliability. The cost allocation for managing such a distribution grid with high penetration of renewables is introduced in

Section 5.3. This cost allocation model reflects the impact of each producer and consumer entity on the distribution grid.

The methodologies presented in this chapter are based on the market and system operator perspective. In addition, the assumption that the DER provide flexibility to the distribution system has been made on top of the recent trends supported by several FP7 European projects [10], [11].

## **5.1 Electricity market equilibrium**

Currently, in many countries, wind power remuneration schemes have been updated, encouraging WPP to compete actively in electricity markets. Consequently, the energy spot price tends to decline as WPP participate with low-price bids in the market due to its near-zero marginal operating cost. In fact, some studies in several markets such as MIBEL [77], Nord Pool [78] and EPEX [79], reveal that WPP will most likely submit their bids with extremely low prices (close to zero) to ensure their scheduling in the market.

In this context, the impact of WPP strategic behavior in electricity markets equilibrium has been widely addressed and indeed, the participation of WPP in electricity markets may lead to a change in the market price. Offering wind power bids at a price close to zero decreases the market price, while at same time it may increase the power imbalances in the balancing market due to the uncertain production of renewables sources.

An emerging challenge is the ability of WPP to participate in reserve markets, so that WPP strategic bidding will affect both energy and reserve markets. This is especially important for the reserve market since this market is designed to maintain the proper levels of security and reliability of the power system. Besides, the reserve market is naturally a small volume market compared to the energy market, so it is expected that not all WPP will be scheduled to provide this service when the system needs it.

Under these challenges, Paper B focuses on analyzing the impact of WPP strategic offering in electricity markets. The analysis undertakes the proportional strategic offering of WPP in energy and reserve markets, which is thoroughly discussed throughout Chapter 4. Additionally, the analysis is carried out taking into account the market equilibrium perspective, based on a multi-agent system for simulating competitive electricity markets.

### **5.1.1 Multi-agent system**

Multi-agent system simulators are often used to simulate the complexity of current electricity markets. In this thesis, the MASCEM simulator has been used for evaluating the energy market equilibrium considering the proportional control strategy behavior of the WPP.

In short, MASCEM is a multi-agent based electricity market simulator which is a modeling and simulation tool to study complex restructured electricity markets operation. It provides market players with simulation and decision-support resources, being able to give them competitive advantage in the market [80]. Furthermore, the simulator can simulate the intrinsic characteristics of some of the most relevant markets, such as the Iberian market – MIBEL, the central European market – EPEX and the northern European market – Nord Pool. Furthermore, the decision support system includes the RealScen tool to automatically define realistic scenarios. This tool uses real data that are usually available on the market operator’s website, to generate realistic scenarios. Besides, this scenario generation tool combines real data with simulation data and, can generate scenarios for different types of electricity markets by, taking advantage of MASCEM’s ability to simulate a broad range of different market mechanisms.

Additionally, the decision support system integrates another multi-agent system (namely, Adaptive Learning Strategic Bidding System – ALBidS [81]) to automatically adapt the players’ strategic behavior according to the operation context and the players’ own goals. In fact, the system provides agents with the capability of analyzing contexts of negotiation, allowing players to automatically adapt their strategic behavior according to their current situation. Figure 5.1 presents the integration of MASCEM with ALBidS, as well as their basic structure.

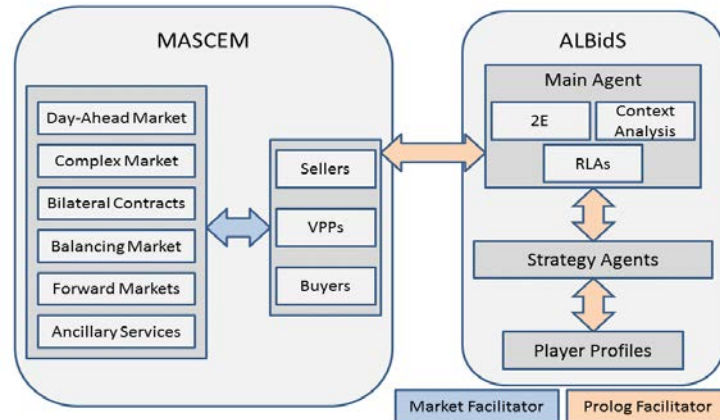

Figure 5.1 – Platform structure and connection of MASCEM and ALBidS [82].

For an in-deep disclosure of the multi-agent system platforms that are used to perform the energy market equilibrium analysis under proportional strategic offering of WPP, the interested reader is referred to [80]–[83].

### 5.1.2 Wind offering assessment

The assessment of the wind offering has been focused on the Iberian electricity market, considering real data from the first week of January 2012. Sellers and buyers have been identified and proportional control strategy have been applied to sellers who consider

wind power in their portfolio mix. Then one part of the available wind power is submitted to energy market and the remaining part is submitted to the reserve market.

To some extent, the energy price in the energy market increases as less available power is allocated to the energy market. This makes the supply curve moving to the left in the market clearing, which means that the amount of demand supplied in the market is reduced and hence the market price is increased. Consequently, the social welfare in the market may slightly reduce because of this ability of WPP to participate in the reserve market. From the simulation presented in Paper B, it is considered that 5% of the total available wind power is submitted to the reserve, while the remaining 95% is submitted to the energy market. This means that all WPP will perform this strategy of allocating 5% of their expected available wind power to participate in the reserve market. This results in a small decrease of the demand supply in the energy market by about 0.28% on average. In contrast, the energy market price can increase by about 4%, in average. Furthermore, the social welfare in the energy market can reduce by about 0.15%, on average. This impact on the energy market may vary, since in some periods the wind impact is very high, while in periods with little available wind power, the impact is even smaller. Thus, the results present only an overview for the entire considered period of the wind control strategy impact in the energy market.

Nevertheless, the impact of the WPP strategy in the day-ahead market will not create very significant changes in the market equilibrium in the long run. In fact, the volume of trading on the reserve market is very small in comparison to the global energy market. Thus, potential available wind power that is allocated to the reserve market rather than being fully allocated to the energy market does not reveal major changes in the energy market equilibrium. However, in scenarios with higher volume of renewable power in the market, the impact of such WPP strategy may be more significant.

## 5.2 Preventive distribution grid management

Considering the increasing participation of DER (namely, composed by RES) in distribution grids, DSOs have to cope with new challenges arising from the stochastic nature of these resources. On the one hand, renewable production is variable, which leads to changes in network power flow within short time periods. In addition, RES have uncertain production, which generates a greater energy imbalance between the expected and the real-time production. In this context, DSOs can no longer fully support their operation and management of the distribution network based on conventional methodologies, which were created based on a system with very limited levels of uncertainty and intermittency. In fact, such conventional methodologies for the operation of distribution networks were based on a passive management of the network to solve local problems.

Today's DSOs have been concerned with such intermittent and uncertain DER production and have been discussing new designs of operation and management

distribution systems with high penetration of DER. In fact, DSOs have started to look at the DER as additional flexibility in the network that can allow them to solve local technical problems in the operational domain, rather than solve those problems only in the planning phase. For this purpose, the DSO needs to operate in an operational planning domain to anticipate potential network problems and contract DER day-ahead flexibility to be ready to solve these potential problems in real-time. Additionally, the use of DER flexibility for managing technical problems can be of greater interest to the DSO, for a deferral of very expensive network investments and expansion.

Nevertheless, the flexibility potential of DER (including flexible operation of the RES) requires a significant change in the present paradigm. The trend in scientific literature and industry is to implement proactive and preventive grid management functions based on forecast information with the possibility to reserve or control DER allocated in the distribution grid [10], [11], [84]. That is, take advantage of some flexibility that DER can provide to the system to assist in the grid management.

In this regard, this section investigates the potential use of DER flexibility to support partially the future operation and management of the distribution network. This research has been built under the assumptions of a proactive and preventive distribution grid management that allows DSOs to improve their capability to solve congestion and voltage problems in distribution systems with high penetration of RES. In fact, such innovative methodology has been proposed and deeply discussed in Paper E. Section 5.2.1 outlines the general framework of the methodology for preventive grid management. Complementarily, Section 5.2.2 provides the main results of the case study of Paper E.

### **5.2.1 Framework for preventive distribution grid management**

A new framework to help the DSO to solve technical problems through contracting flexibility from DER has been designed. The conception and design of this methodology (illustrated in Figure 5.2) is based on two distinct stages. The first stage consists of DSOs that contracts upward and downward flexibility from DER at day-ahead stage to manage the grid in real-time during the second stage problem. In fact, the DSO needs to contract flexibility in advance to use it when needed in real-time operation. Thus, the amount of contracted flexibility will depend on the expected needs for solving potential congestion and voltage problems in the distribution grid which are correlated with the uncertain production of RES.



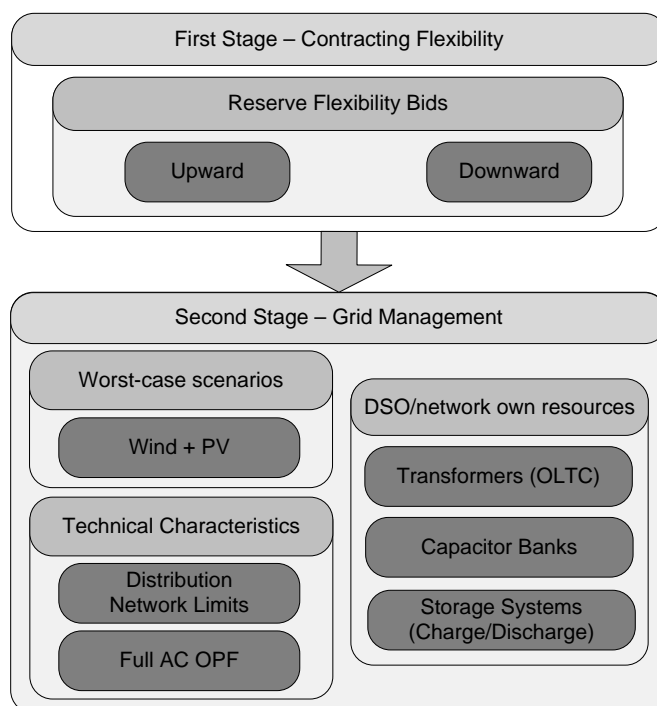

Figure 5.2 – Diagram of framework for a preventive management of distribution grid.

It is noteworthy that within this framework, DER (such as, wind, PV, other distributed generators and demand response programs) are able to provide upward and downward flexibility bids in the day-ahead stage. In fact, DER aggregators or individual players must, to some extent, ensure the provision of such flexibility bids. This means that they need to know their expected operating point in advance to submit such offers to the DSO. For example, suppose a wind power plant participates in the market and simultaneously offers flexibility to the DSO, as shown in Figure 5.3. The wind power plant uses only a part of the expected wind power forecast to participate in the energy market – establishing an operating point. That is, the energy bid is now the expected operating point of the wind power plant. The difference between the expected forecast and the operating point is provided as upward flexibility for the DSO. Therefore, the downward flexibility can be offered by taking the operating point as the upper limit.

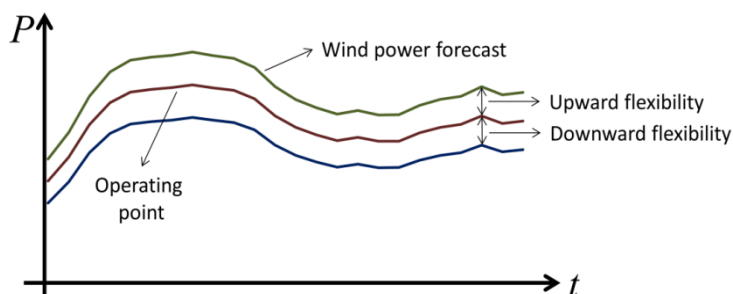

Figure 5.3 – Illustrative example of wind power split in energy and upward and downward flexibility.

Strategic bidding for renewables (wind and PV) can follow similar approaches as discussed in Chapter 4, i.e., it can provide flexibility bids based on the expected profit from supplying this upward and downward flexibility to the DSO, accounting for the costs of changing their operating point, as well as their uncertain production.

Following these assumptions, the DSO contracts the flexibility of the DER based on capacity payments.

The second stage of the model consists of the real-time management of the distribution grid considering the contracted flexibility in the day-ahead stage and the energy operating point of each DER. In addition, grid management is completed by the internal flexibility of the DSO (this includes transformers with on-load tap-changing, capacitor banks and ESS), accounting for the technical limitations of the network. Under this design, ESS are fully managed by the DSO to assist in system management and to mitigate the effects of uncertain RES production. In addition, storage systems allow for a multi-period flexibility helping to avoid grid congestion. Furthermore, the model incorporates an AC OPF to validated and respect the technical network limits.

Overall, the two-stage model for operating the distribution grid aims in minimizing the operating costs of the DSO by contracting flexibility of the DER in day-ahead stage (first stage) to solve and operate potential congestion and voltage problems in the real-time operation (second stage). To this aim, a two-stage robust optimization approach able to deal with uncertain production of DER, while providing robust solutions that include high reliability levels is performed. More specifically, the problem is modeled as a multi-period and multi-stage robust optimization problem where the uncertainty of the RES production is modelled based on the worst-case scenario. A general mathematical form of the above problem follows

$$\text{Min}_x \sum_t^T C_t^{DA} x + \text{Max}_h \text{Min}_y \sum_t^T q_t^{RT} y \quad (5.1a)$$

$$\text{s.t. } T_t x + H_t y = h, \quad (5.1b)$$

$$A_t x + B_t y \geq h, \quad (5.1c)$$

$$y \geq 0, \quad (5.1d)$$

$$\text{s.t. } h \in W, \quad (5.1e)$$

$$\text{s.t. } G_t x \geq g_t, \quad (5.1f)$$

$$x \geq 0, \quad (5.1g)$$

where model (5.1) has a min-max-min structure that allows the determination of the minimum cost for contracting flexibility under a minimum recourse operating cost in real-time considering the worst-case realization of the uncertainty. Indeed, the

maximization problem chooses the worst-case realization of the uncertainty set  $W$  (5.1e). The corresponding full adaptive robust formulation can be found in Paper E, following the theoretical principles presented in Section 3.4.2. In more detail, the day-ahead function of (5.1a) for contracting flexibility  $C_t^{DA}$ , considers the upward and downward offers in power and price from DER, namely wind, PV, other small generators and demand response. All the flexibility offers are constrained by the internal limits of each producer, given by inequalities constraints (5.1g). The vector  $x$  parameterizes all the first-stage decision variables related to the upward and downward flexibility of distributed generation, wind, PV and demand response. In contrast, the vector  $y$  of recourse optimization variables consists of actions taken during real-time operation for solving congestion and voltage problems. The set of equality equations (5.1.b) includes active and reactive power balance, reactive power consumption, capacitor banks tap-changing, transformers with on-load tap-changing, and energy storage balance. In parallel, the set of inequality constraints (5.1c) includes operating costs for balancing the system, upper and lower bounds of active and reactive power to the upward and downward flexibility of all energy resources (distributed generation, wind, PV, demand response and ESS). Additionally, non-simultaneity of storage systems, transformers capacity, lines capacity, and upper and lower bounds of voltage angles and magnitude are considered. It is noteworthy that the costs for activating the flexibility of DER in real-time operation, as well as for the use of tap-changing in capacitor banks and transformers are considered. Charge and discharge costs for internal management of the ESS are also included. All problem constraints mentioned above are not presented in this thesis, but interested readers are referred to Paper E for in-depth detail and explanation.

### 5.2.2 Assessment of preventive distribution grid management

The proposed preventive distribution grid management was applied in a distribution network with high penetration of RES to evaluate its effect in solving potential congestion and voltage problems. Detailed system data and uncertainty modeling assumptions are provided in Paper E. It is assumed that the DSO fully controls the transformers with on-load tap-changing, capacitor banks and ESS.

To assess the value of the proposed methodology, it is studied the difference between the robust solution proposed in this method and a deterministic solution (somehow closer to the reactive management of today's DSO operation mode). The deterministic solution is based on the deterministic version of the proposed robust model, where the conditional mean forecast for renewable production is settled as the expected power generation for those resources, i.e., the deterministic version does not account for uncertain production from RES. In contrast, the robust model considers the uncertain production through the uncertainty set. Modelling the uncertainty set for robust optimization through vertices can lead to numerous vertices that increase the computational effort. Thus, the uncertainty set was delimited by only selecting a

limited number of vertices based on the efficiency ratio of the methodology in terms of computational effort and solution quality.

In addition to the model simulation, a validation of the proposed solution was accomplished under real-time operation. The validation stage entails performing an hourly optimal power flow that considers out-of-sample data of potential realization of wind and PV resources. During the real-time operation process, it is assumed that only the flexibility, contracted by the DSO, can be used to solve potential congestion and voltage problems. In cases where contracted flexibility is not sufficient to solve the congestion problem, wind and PV curtailment and load shedding are used as last resort measures to balance the system. Thus, the performance of the proposed methodology can be assessed together with the conventional deterministic approach. In fact, Paper E shows that the proposed approach is 1.07% more economical than the deterministic approach for the considered case study. This is due to the broad flexibility that is scheduled under the worst-case scenario in every operating hour. This only occurs in cases and hours of congestion and voltage problems, where the amount of flexibility required to solve the problems is considerably greater than in cases without significant congestion problems.

The usefulness/performance of both methodologies for solving congestion problems in an entire day is illustrated in Figure 5.4. The blue area represents the flexibility contracted by the DSO in the day-ahead stage, while the red area represents the load shedding needed by the approach to solve the congestion problem in real-time operation. In parallel, the green line illustrates the total power used by the DSO to manage the grid during the validation process, while the blue line accounts for the flexibility activated during the real-time process.

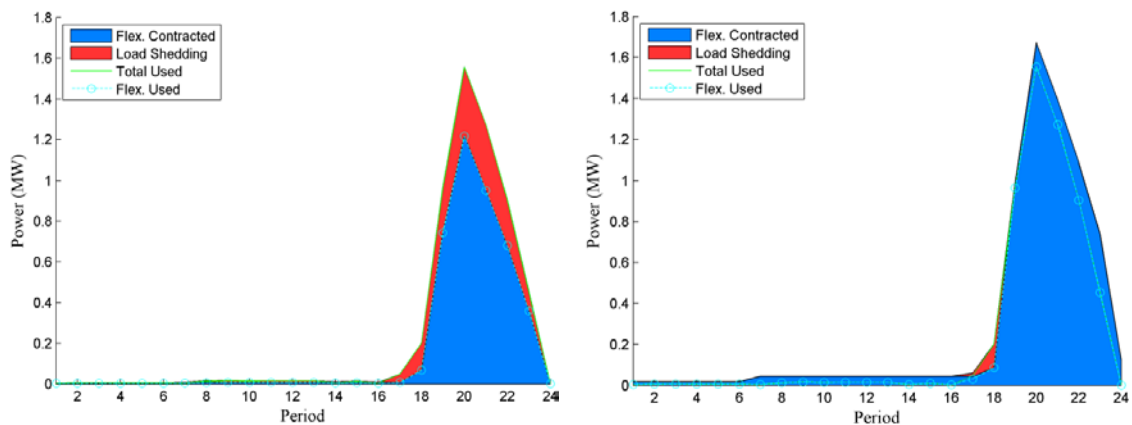

Figure 5.4 – Contracted, used flexibility and load shedding (in expectation) over 24-hour for deterministic (left) and robust (right) approaches under real-time operation.

From Figure 5.4 it can be seen that the amount of flexibility that the DSO contracts in day-ahead stage from the DER is different for the deterministic (left) and the robust approach (right). In fact, the flexibility that is contracted in the deterministic approach is not sufficient to meet the needs during the real-time operation in periods 17 to 23. This

means that the DSO has to shed demand during these periods to solve the congestion and voltage problems that have arisen. In contrast, the robust approach had mostly enough contracted flexibility to solve the problems during real-time operation, only in period 17 there was a need for shedding. The shedding in this period occurred because the expected worst-case in that period differed from the true worst-case. These kinds of events can occur, because of limitations in the modulation of the uncertainty set. By ensuring an uncertainty set with a low number of vertices (to decrease the computational effort), some of the robustness is lost in the process. Indeed, the uncertainty set of the robust approach in this figure contains 6 vertices. This large complexity of the model leads to high computational time which is the main drawback of the proposed methodology. Thus, reduced numbers of vertices for modeling the uncertainty set are required to achieve lower computational effort. In more detail, the deterministic approach takes about 8 minutes to converge to an optimal solution, while robust approach (considering 6 vertices) can take up to 16 hours.

Nevertheless, the robust approach is more economical by ensuring a higher reliability than the deterministic approach for periods where congestion problems are expected. In contrast, in periods where the expectation of congestion problems is not of concern (i.e., in periods where a deterministic approach is enough to solve the expected problems), the robust approach is more expensive for the DSO. An ideal approach would combine the best performance of the deterministic and robust approach.

Additionally, Figure 5.5 shows the empirical cumulative distribution function of the expected operating costs of the entire day for deterministic and robust approaches (considering different number of vertices that model the uncertainty set).

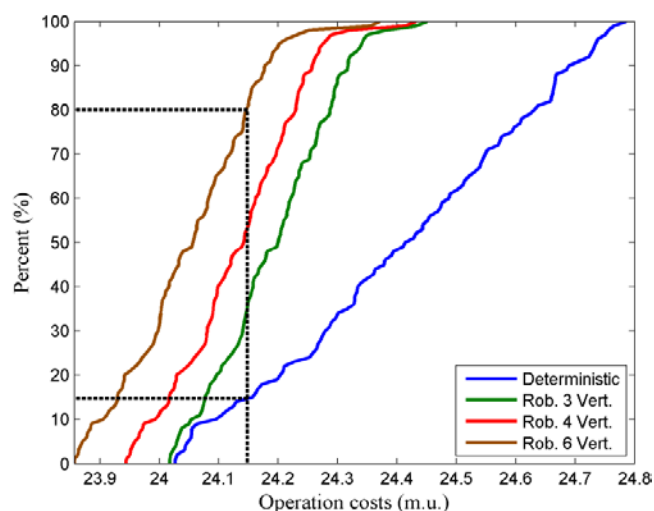

Figure 5.5 – Empirical cumulative distribution function of expected operating costs for deterministic (blue line), robust 3 vertices (green line), robust 4 vertices (red line) and robust 6 vertices (brown line) approaches.

From Figure 5.5 one can evaluate the probability of the expected realization of renewables power production and consequently the congestion problems that might occur in a range of estimated operating costs. For an illustrative example, an expected operating cost of up to 24.148 m.u. is expected to happen in 80% of the scenarios of the robust approach with 6 vertices. In contrast, the same operating costs should occur in 14.69% of the realization scenarios for the deterministic approach. As a general conclusion, the enhanced flexibility helps the DSO to deal with severe congestion problems in the network.

As general remarks, one can state that the proposed method can be useful to the DSO to contract sufficient flexibility of the DER to assist the management of the distribution grid. Compared to the proposed robust approach, the deterministic approach is cheaper in the day-ahead stage, but more expensive in real-time operation, i.e. the robust approach provides some savings to the DSO by reserving some extra flexibility at day-ahead stage to be used during real-time operation, thereby avoiding load shedding. Furthermore, the level of robustness of the proposed methodology depends on the number of vertices that model the uncertainty set, however such additional robustness is paid in the computational effort, since the problem becomes more complex to solve.

### 5.3 Grid cost allocation

Along with this new paradigm of power system operation, considering high penetration of distributed generation (including wind and PV), the existence of ESS, the growing introduction of EV and the active participation of consumers through demand response programs, make conventional methods no longer suitable to determine the costs allocation of the distribution grid. In fact, current cost allocation methods for distribution grids equally allocate all costs to consumers, without considering the individual impact of each participant (supplier and consumers) in the network usage. Under the expected characteristics of future distribution grids, some grid participants will play different roles from time-to-time. For instance, ESS and EV with vehicle-to-grid ability can behave as consumers or producers in different periods. Furthermore, consumers with demand response programs can have a distinct impact on network usage compared to conventional consumers. Furthermore, other DER, including wind and PV, can use the network to supply consumers or help in network congestion management.

Within this scope, this section investigates new methods and mechanisms for distributing distribution network usage costs among all users of the network (producers and consumers), promoting equity, fairness, impartiality and equality. A methodology combining fixed, network usage and losses costs for all network users is investigated in Paper A. The method combines different approaches of cost allocation by developing a hybrid approach that fills the gaps of each individual conventional cost allocation method. Besides, costs for any type of producers and consumers are allocated according to their intrinsic characteristics and impact on the distribution network. In more detail,

the general framework of cost allocation to all network users in the distribution grid is discussed in Section 5.3.1. Finally, the main results of the impact of this methodology on a common distribution grid with high penetration of DER is evaluated in Section 5.3.2 and deeply discussed in Paper A.

### 5.3.1 Framework for cost allocation of distribution grids

A cost allocation model for DER in the distribution grid, considering the combination of three distinct allocation methods (fixed, network use and losses costs) with the aim of take advantage of the main qualities of each one, is proposed in Paper A. An illustration of this model is shown in Figure 5.6. In fact, the cost allocation model is divided into three different sequential phases to properly determine the costs for each participant in the network. The first phase considers an economic dispatch algorithm for the distribution grid that is used to schedule all DER. This algorithm aims to minimize the operation costs of the DSO considering all types of DER (distributed generation including wind and PV, ESS, EV with capacity to charge and discharge energy, as well as consumers with demand response programs), as well as external suppliers (i.e., suppliers that provide energy through upstream connections of the distribution grid). This algorithm considers the feed-in contracts that impose the energy delivery by some DER, especially the RES. In addition, the algorithm contains an AC optimal power flow to validate the dispatch of DER in the distribution grid. From this algorithm, the Locational Marginal Price (LMP) will be determined in each node of the network. The full length of the optimization process to dispatch all the energy resources in the distribution grid can be found in Paper A.

Note that the optimization algorithm of the first stage can be replaced by any other algorithm that the DSO can use to obtain the DER scheduling and, consequently, the LMP in each node. For instance, the results of the preventive distribution grid management methodology proposed in Paper E and discussed in the previous Section 5.2 can partly be used in the first stage of the cost allocation methodology.

The second stage of the cost allocation model uses the energy resources scheduling from the first stage to determine the contribution of each single energy resource (both suppliers and consumers) to the use of each network branch. To this end, two distinct tracing algorithms, namely Kirschen's [85] and Bialek's [86], were implemented and tested. Both algorithms estimate the network use of each resource type via proportional sharing principle, i.e., quantifying the percentage of power that each resource imposes in the power flow of each network branch.

Both tracing methods uses upstream and downstream-looking algorithms to determine the impact of each generation and consumption resource on the network power flow, respectively. The main differences and characteristics of both tracing algorithms can be found in more detail in Paper A.

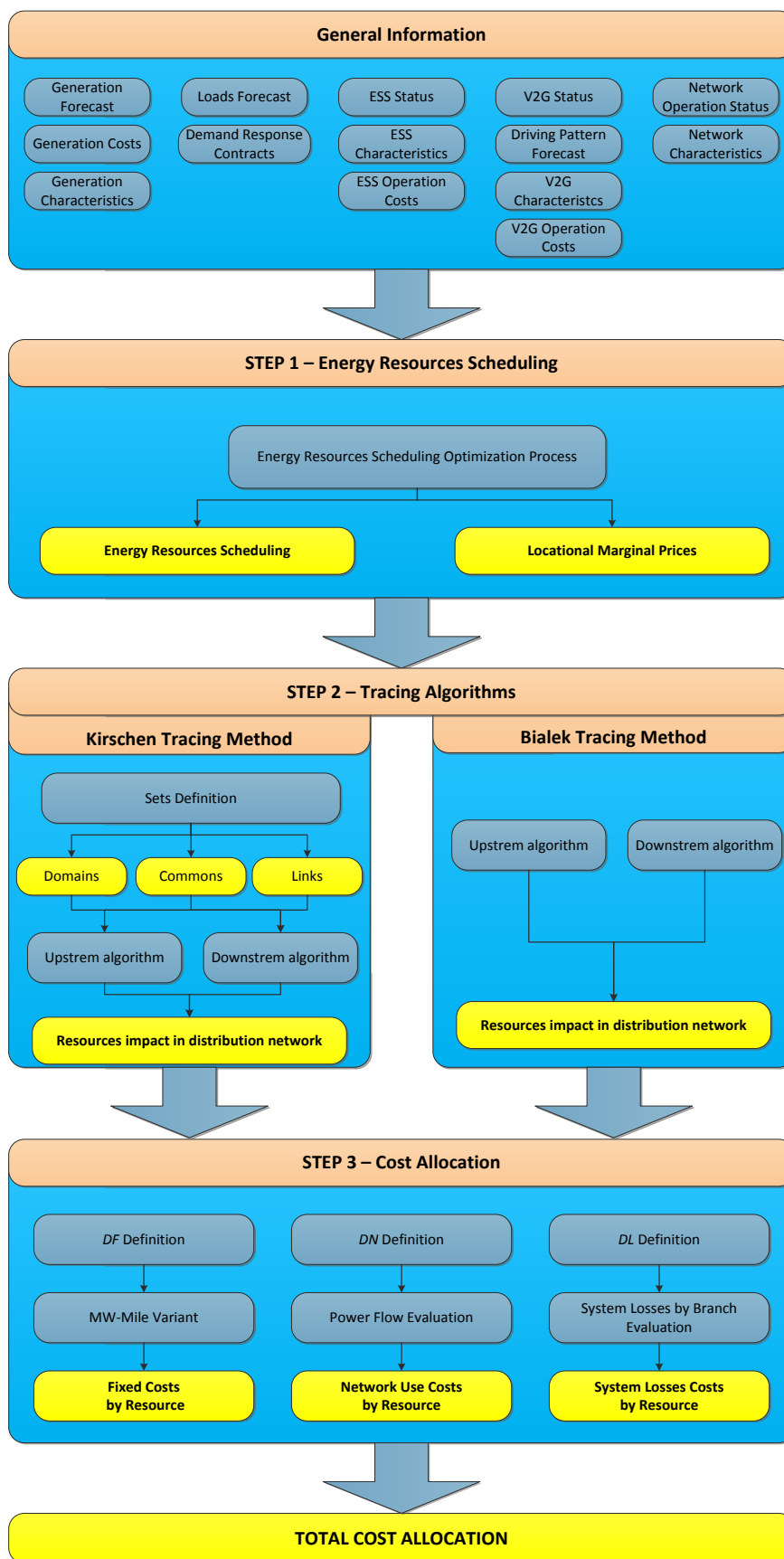

Figure 5.6 – Diagram of costs allocation model for distribution grids with high introduction of DER.



Nevertheless, some considerations must be taken into account when using such algorithms for tracing the power flow of DER. More precisely, in such algorithms, demand response programs are not directly seen as network participants. Unlike energy scheduling, demand response is not seen as a generator but rather as part of the load entity that reduces the load consumption. In practice, the demand response is not divided from the consumption entity. This means that the demand response curtailment is deducted from the initial energy consumption of that load. Thus, it can be represented as a negative cost for the load entity due to less load impact on the system. In contrast, resources like ESS and EV are divided into two distinct functions (i.e., the discharge and charge processes) and are considered in the tracing algorithms as both generators and loads. The allocated cost for the ESS and EV considers the impact of charge and discharge processes in the distribution grid.

This is done in the third stage of the model where three distinct costs (fixed, network usage, and losses) are allocated to each resource. A variant of the MW-mile [87] is used to cost allocate the resource according to its impact in each branch of the network. The fixed cost considers the network operation and maintenance costs that the distributed system operator can have to ensure the proper functioning of the different equipment's. Additionally, the fixed costs may cover also the investment costs of network expansion and new equipment. The formula for fixed costs by distributed generation unit is given by

$$C_{i,j,dg}^{Fixed} = \frac{DF_{i,j,dg} C_{Branch\ i,j}^{Fixed} X_{DG}}{Flow_{i,j}}, \quad (5.2)$$

where  $Flow_{i,j}$  is the power flow in the branch  $i,j$ ,  $DF_{i,j,dg}$  is the distributed generation contribution in the power flow of the branch  $i,j$ ,  $C_{Branch\ i,j}^{Fixed}$  is the fixed cost associated with the branch  $i,j$ , and  $X_{DG}$  is the payment factor for distributed generation units. The pay factor is used to establish the contribution that each type of resource has in the fixed costs. This factor ranges from 0 to 1, and is imposed by the DSO based on strategic, political and environmental reasons. Each type of resource has a specific payment factor and the sum of all factors is equal to 1. Note that the factor is assigned to the entity type, i.e., load entities with DR programs share the same pay factor.

In the case of ESS and EV with vehicle-to-grid ability, t fixed costs are determined similarly to distributed generation resources. However, different to distributed generation the charge and discharge capability are considered. The fixed costs of ESS considering the charge and discharge process is as

$$C_{i,j,st}^{Fixed} = \left( \frac{DF_{i,j,st}^{Ch} C_{Branch\ i,j}^{Fixed}}{Flow_{i,j}} + \frac{DF_{i,j,st}^{Dch} C_{Branch\ i,j}^{Fixed}}{Flow_{i,j}} \right) X_{ST}, \quad (5.3)$$

where  $DF_{i,j,st}^{Ch}$  is the contribution of the ESS to the power flow of branch  $i,j$  during the charging process, while  $DF_{i,j,st}^{Dch}$  is the contribution of the energy storage unit to the power flow of branch  $i,j$  during the discharging process. The pay factor is assigned to the entity, regardless if the resource is charging or discharging. The same formula (5.3) is applied to EV with vehicle-to-grid capability.

Nevertheless, the use of such ability of sharing costs among several types of energy resources can create some economic inefficiency, due to the use of distribution factors that quantify the impact on the network. Thus, the costs related to this inefficiency are allocated to load entities by

$$C_{LTC,i,j,l}^{Fixed} = \frac{DF_{i,j,l} C_{\psi,i,j}^{Fixed}}{\sum_{l=1}^L DF_{i,j,l}} + C_{i,j,l}^{Fixed}, \quad (5.4)$$

where  $C_{LTC,i,j,l}^{Fixed}$  are the total fixed costs associated to each load unit in branch  $i,j$ , and  $C_{\psi,i,j}^{Fixed}$  are the inefficiency costs in the branch  $i,j$ . The inefficiency costs of branch  $i,j$  are determined by the difference between the fixed costs of branch  $i,j$  and the sum of all fixed costs determined for each type of resource in branch  $i,j$ , hence

$$C_{\psi,i,j}^{Fixed} = C_{Branch,i,j}^{Fixed} - \left[ \sum_{dg=1}^{N_{DG}} C_{i,j,dg}^{Fixed} + \sum_{l=1}^{N_L} C_{i,j,l}^{Fixed} + \sum_{st=1}^{N_{ST}} C_{i,j,st}^{Fixed} + \sum_{v2g=1}^{N_{V2G}} C_{i,j,v2g}^{Fixed} \right]. \quad (5.5)$$

For more detail on determining inefficiency costs, see Paper A.

In what concerns to the costs of network usage, a similar approach to fixed costs is used. Indeed, the costs concerning the network usage are related to the power flow in each branch of the network,

$$C_{i,j,dg}^{NetUse} = \frac{DN_{i,j,dg} C_{Branch,i,j}^{NetUse} X_{DG}}{Flow_{i,j}}, \quad (5.6)$$

where  $C_{Branch,i,j}^{NetUse}$  is the difference between the LMP of each bus that belongs to branch  $i,j$ . In usual operation, the difference between LMPs of each bus can reflect the losses, however, under critical operation conditions, this difference of LMPs may reflect the congestion LMP.

Regarding the losses cost in the network, the model uses a formula similar to the other fixed and network usage costs. However, the cost of losses in each branch is determined based on the highest LMP of the buses that connect branch  $i,j$ . The total costs for each type of energy resource are determined as the sum of all fixed, network usage and losses costs in all branches of the network. The detailed formulation of the entire cost allocation model can be found in Paper A.

### 5.3.2 Assessment of cost allocation method

The method outlined in the previous section is applied in a case study based on a distribution grid with high DER penetration, where it is compared the performance and impact of the Kirschen's and Bialek's tracing algorithms in the cost allocation model. This section focuses on the total costs for type of energy resource and for each branch of the distribution network. Detailed system data and results of each stage of the model can be found in Paper A.

The total costs allocation of the Kirschen's and Bialek's approaches for each energy resource type in each network branch at hour 21 is illustrated in Figure 5.7 and Figure 5.8, respectively. The period 21 has been chosen because of the large dispatch of DER in this period, evidencing the distribution costs for different types of resources in the network. From both figures, it can be seen that external suppliers and loads are the energy resources with the highest share of total network costs. External suppliers are the main provider of the system as it contains the energy that flows through the upstream connection and supplies most of the internal energy consumption of the distribution grid.

Comparing both approaches, Kirschen's approach assigns higher costs to DER than the Bialek's approach. Thus, the consumer entities have higher costs in the Bialek's than in the Kirschen's approach. On average, Bialek's approach allocates 70% of the total system costs for consumer units, while the Kirschen's approach reaches 54%. This significant difference in cost allocation stems from the different intrinsic characteristics and considerations on tracing the flow contribution of each resource in the grid. In fact, Kirschen's approach behaves well in small networks with a single direction of flow, while Bialek's distribution factors fit easily into large networks with distinct directions of the power flow in branches. Within this scope, one can draw the conclusion that Bialek's approach is probably more suitable for future distribution grids than Kirschen's approach. This general remark is also corroborated by the significant costs for ESS and EV under Kirschen's approach, especially when the power production of these resources is not as prevalent as the remaining DER. Similarities between both approaches occur in the branches close to the upstream connection, where external suppliers collect a significant amount of the costs of those branches.

In summary, the different results of the proposed model cover several cost allocation methodologies under the future paradigm of distribution grid operation with large-scale DER integration. Moreover, this complete cost allocation model is of greater interest for distribution operators allocate network usage costs in a fair way and enables energy resources and retailers to simulate and evaluate their potential expected network usage costs.

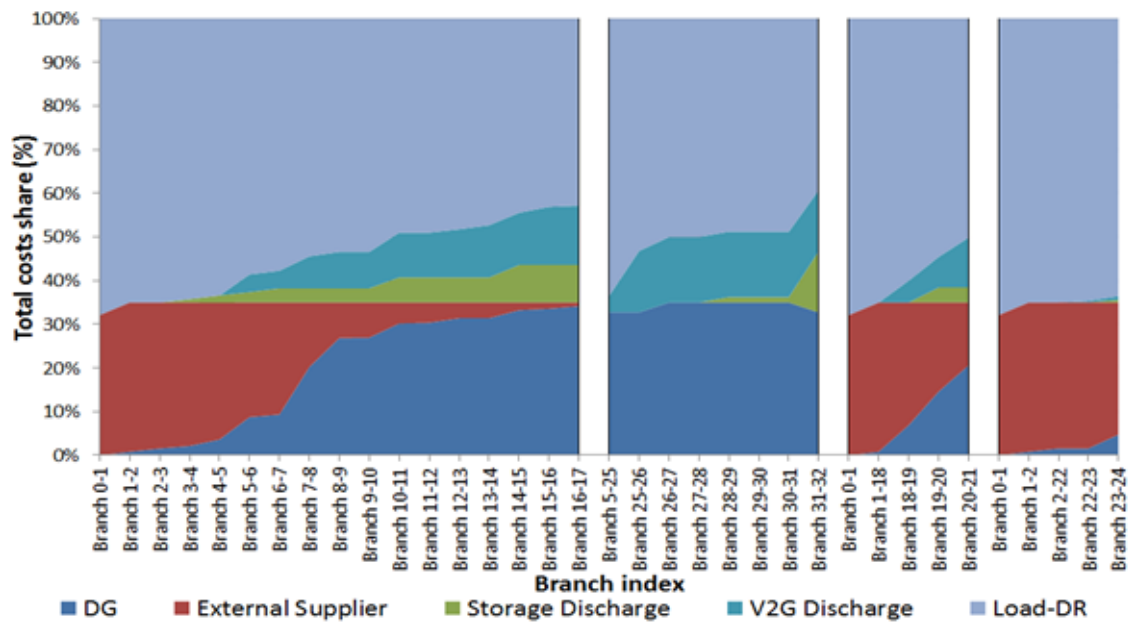

Figure 5.7 – Total costs in each branch of the network by resource considering Kirschen's approach in period 21 of the energy scheduling. The figure is divided by sections representing the radial sections derived from the main branch of the distribution grid.

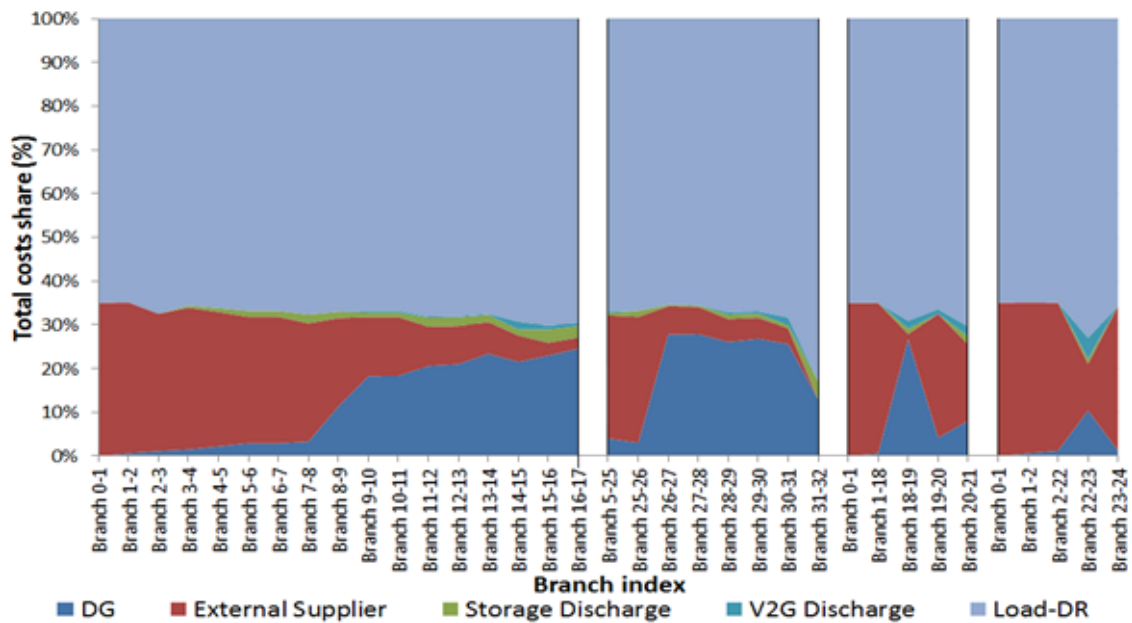

Figure 5.8 – Total costs in each branch of the network by resource considering Bialek's approach in period 21 of the energy scheduling. The figure is divided by sections representing the radial sections derived from the main branch of the distribution grid.



# Conclusions and future research

---

The increasing integration of renewable resources into power systems as result of ambitious government targets, has been introducing new challenges that call into question the efficiency of the existing operational market and power system models. More precisely, the high-share of renewable production forces decision-makers to adapt their models for power systems and electricity markets considering the uncertain and variable production of renewable resources. Market and system operators should find solutions for the challenges arising from large-scale integration of stochastic renewable generation, as well as investigate new possibilities to enhance the flexibility provided by these resources to the power system.

This thesis addresses two main issues related to the large-scale integration of RES in electricity markets and system operation both from the perspective of renewables producers and system/market operator. The first issue considers the strategy of renewable resources offering in energy and reserve markets. The second challenge concerns the preventive management of distribution networks with high penetration of DER, including renewables, and considering the flexibility of such resources to solve congestion problems. In the same topic, the allocation of network usage costs is also considered.

## 6.1 Overview of contribution

New business opportunities are arising for the wind power producers. These result from the recent technological advances associated with the increasing penetration of renewables, in particular, the wind power control technology that allows wind power producers to provide reserves. In fact, the development of new market designs for the participation of RES in reserve markets is a topic recently discussed in the literature with the aim of fully integrating renewable energy in various market products. To cope with this complex participation of uncertain resources in different markets, new market mechanisms must be developed to encourage and enable renewables producers to provide both energy and reserve services. A new market model for the optimal offering of renewable producers in energy and reserve markets such as those proposed in this thesis and presented in Papers C, D and F, is crucial to bring renewable production to

the reserve markets. These models clearly open the door for RES to participate in the energy and reserve markets. The models enable improved revenue for renewable power producers and greater integration of renewables into the power system.

In more detail, Paper C, shows that the participation of WPP in a new market where wind can offer both energy and reserve can increase the expected revenue of WPP in comparison with energy-only participation. This approach considers energy and reserve costs for energy and reserve power imbalances. Indeed, through the analytical derivation of two distinct control strategies for wind supplying energy and reserve to the system (namely, proportional and constant wind power control) and assuming that the wind producer behaves as a price-taker, it was found that such optimal participation in both markets is of greater interest to wind power producers. Furthermore, the outcomes of the case study revealed that proportional wind control strategy provides higher expected revenue than constant wind control strategy. However, the optimal offering in the energy and reserve markets depends heavily on the expectation of prices and penalties for energy and reserve services. This means that even though it is technically possible, it is not always optimal for wind power to provide reserve in a market environment.

Moving beyond the proportional wind power control to offer in energy and reserve markets, a stochastic model was developed in Paper D to determine the optimal bid of energy and reserve, considering different share of energy and reserve between the day-ahead and balancing markets. The main focus of this work was to assess the effect of strategic bidding of a wind power producer, bringing decisions close to real-time. The aim of this approach is to enable wind power producers to use better forecasts of their wind power production to adjust their potential energy and reserve penalties for energy and reserve imbalances at the balancing stage. The offering strategy for energy and reserve is formulated as a two-stage stochastic model considering two options: (i) a fixed share, and (ii) a flexible share of energy and reserve between the day-ahead and balancing stages. From the case study, it was concluded that allowing a different share of energy and reserve between the day-ahead and balancing stages can increase the expected revenue of a wind power producer. Thus, bringing decisions close to real-time can improve the quality of wind power producers' decisions and reduce the lead time effect between day-ahead and balancing stages.

Under such a flexible sharing mechanism between the day-ahead and balancing stages, decisions should be evaluated under the different strategic behaviors of wind power producers. In fact, decisions made under a full flexible mechanism require a certain level of perfect information on the possible realization of uncertain wind power production at the balancing stage, which is difficult to obtain. Within this scope, Paper F proposes and develops models that allow a certain degree of freedom to make decisions between the fixed and flexible share mechanisms, while reducing the risk of insufficient knowledge of the balancing stage, which generates poor decisions. Indeed, two

additional methods based on PLDR and McCormick relaxation were proposed to give different decisions between the fixed and flexible stochastic mechanisms. The piecewise linear decision rules support their decisions based on linear approximation characteristics that allow them to perform decisions close to the fixed stochastic model. On the other hand, the McCormick relaxation associated with a coefficient to adjust the share of energy and reserve between the day-ahead and balancing stages gives a full degree of freedom for wind power producers to impose their decisions depending on their own risk assessment. Such methodologies provide a range of solutions and decisions that may fulfill different goals and behaviors of wind power producers.

In the context of these techniques to support wind power offering in both energy and reserve markets, market operators will play a key role in encouraging or discouraging wind power producers from participating in the reserve market. In fact, the market operator has to assess the impact of such simultaneous renewable participation in both energy and reserve markets, and ensure that appropriate price signals will encourage the participation of wind power producers in both markets. In this context, Paper B presents an assessment of the energy market equilibrium considering different levels of RES participation in the reserve market. The case study, carried out in the MASCEM simulator, allowed to evaluate the impact of this RES participation in today's energy market. This work showed that the renewable participation in the reserve market may slightly reduce the social welfare in the energy market, resulting in an increase of the spot price. Still, this impact is not of great concern to the market operator, since the volume of trading in the reserve market corresponds to a very small part of the energy market hence, the energy market equilibrium over time does not reveal major changes. However, it is possible to see a different impact on markets with high share of renewable energy, since the difference between the marginal price of renewable energy and others generators is significant. This work can be further used to evaluate the equilibrium of the energy and reserve markets in markets with high RES penetration.

Towards a power system based on DER, the conventional operation and management of distribution systems are no longer suitable to the new characteristics of the system. Distributed energy resources, which mainly comprise renewable sources, will bring uncertain and intermittent production to distribution systems. As a result, they will induce a different flow in the network branches, whereby the level of intermittent production in the network's power flow can either solve or create congestion and voltage problems. In addition, tariffs for the use of the distribution grid need to be updated because there are new energy resources that can behave as producers or consumers, thus imposing different impact on the network usage. To this end, Papers E and A focus on the preventive grid management and cost allocation methods for future distribution grids with high penetration of renewable sources, respectively.

The issue described above about the need of new operation and management methods for distribution grids was investigated in Paper E. In fact, this work proposes a new



preventive operation and management method to cope with the challenge of DER (mainly comprising RES) in distribution grids. This approach considers a preventive distribution network management able to solve potential congestion and voltage problems in future distribution grids with a high level of uncertain production. More precisely, a robust optimization framework was proposed to solve congestion and voltage problems in the distribution network based on the flexibility provided by all types of DER. The flexibility of DER can be contracted on a day-ahead basis to be used by the DSO during real-time operation. It was shown that the uncertain and variable production can actually provide flexibility to the system for solving congestion and voltage problems. The test-case results have shown that the proposed method is more efficient than deterministic methods for dealing with uncertain and variable production of renewable sources in the distribution grid. In fact, using the flexibility of DER to solve operational and management problems can defer investment costs and expansion of the distribution system.

Under this new operational planning paradigm of high integration of DER in distribution grids, network tariffs must be updated considering the new characteristics of these resources in order to share fairly the costs among all users of the network. To this end, this thesis proposed through, Paper A, a new method for the cost allocation of network usage in a fair way, taking into account fixed, network usage and losses costs. The method follows the principle of *proportional sharing* to estimate costs among all network users. One of the main advantages of this approach is the ability to differentiate the impact of suppliers and active consumers in network usage, allowing the distinction of resources able to behave as suppliers and consumers (e.g., energy storage systems and electric vehicles with vehicle-to-grid ability) over time. The test-case exploited the features of this model, revealing the importance of this method for energy resources and retailers to simulate and evaluate their potential network costs in network usage of future distribution grids. Additionally, and based on local electricity markets, this PhD work opens the door to further studies on the competition for network usage between small producers and active consumers. From the perspective of local electricity markets (where local producers and consumers exchange energy) at a district, municipal or community level, who uses the network should share fair cost allocation. Moreover, the network usage will be even more crucial in local electricity markets that follow the recent trend of a peer-to-peer market as it will reflect the network usage cost of every small producer and active consumer.

Lastly, all the methodologies for participation in electricity markets and operation of future systems with high penetration of renewable sources, proposed and implemented in this thesis and in the six enclosed papers (four published and two under review), clearly show the relevance of the achieved findings to the literature. Moreover, the success of this PhD work is also sustained by the accomplishment of the defined objectives.

## 6.2 Future research

Throughout the development of this thesis, a number of potential future research directions to improve the integration of renewable sources in power systems have emerged. The first one entails the bids of RES in the energy and reserve markets. Secondly, the recent trend towards preventive management of distribution grids has to be improved.

Regarding the offering in energy and reserve markets, four relevant extensions can be carried out. *i)* Improving the performance of the piecewise linear decision rules by optimizing the number and value of the breakpoints in the piecewise function. This can be done by studying the advanced version of piecewise linear decision rules with general segmentation. This approach can approximate the piecewise function to the natural recourse function of the problem. *ii)* The mathematical modulation, implementation and validation of different control policies for the split of wind power available in energy and reserve markets can be extended. The study of different wind power control strategies, such as the  $\Delta P$  control and output cap, can provide different market and operation strategies for wind power producers. *iii)* Extending the optimal bid definition considering the intra-hour variability can reduce the potential balancing costs for energy and reserve deviations. This direction points up to intermittent wind production in smaller periods than one hour, giving a better understanding of the potential bid of the wind power available over the hour. *iv)* From the market point of view, a certain relationship must be ensured between energy and reserve prices and penalties to allow joint participation in both market products. These proper price signals or penalties should be studied from the market operator's perspective to ensure that wind power producers (and others) do not present binary bidding behavior in only one market. In particular, the assumption proposed in this thesis in generating a penalty for the negative reserve imbalance should be very well planned to encourage wind power producers to offer on the reserve market, but at the same time ensuring that producers will not exercise market power. This means that the reserve penalty should be neither too low nor too high in comparison to the price and penalties for the energy market.

In what concerns the second direction of future research, regarding the preventive grid management with a high level of renewable penetration, the extensions are twofold. Firstly, the complexity of the proposed robust model makes the methodology impractical in real networks for the DSO, since the computational effort is excessive, taking several hours. Thus, several ways of reducing problem complexity or computational effort can be studied. On the one hand, reducing the complexity of the methodology can be done through the linearization of the nonlinearities of the model, such as the AC OPF. For instance, the AC OPF can be formulated in the form of a second-order cone programming or semidefinite programming that makes the model convex at the price of giving approximate solutions. On the other hand, computational performance can be improved by considering different optimization algorithms, such as

---

meta-heuristics, that can significantly reduce the computational effort of the model, also at the price of only guaranteeing approximate solutions. In addition to these two suggestions, the construction of the uncertainty set for the robust approach by other means (such as ellipsoidal uncertainty set) may most likely yield good representation of the worst-case solution. The second extension follows the idea of improving the developed model by adding conventional tools used by the distribution operators to manage the network. For instance, network reconfiguration and acceptance of voltage deviations. However, these tools can increase the complexity of the model and therefore may be more difficult to solve. Nonetheless, these novel extensions are necessary to improve the integration of renewable sources in the power system, as well as to reduce the computational burden of the proposed complex model, thus allowing its application in real-world cases.

# Bibliography

---

- [1] J. Notenboom, P. Boot, R. Koelemeijer, and J. Ros, “Climate and energy roadmaps towards 2050 in north-western Europe,” Netherlands Environmental Assessment Agency, 2012.
- [2] E. Y. Bitar, R. Rajagopal, P. P. Khargonekar, K. Poolla, and P. Varaiya, “Bringing wind energy to market,” *IEEE, Trans. Power Syst.*, vol. 27, no. 3, pp. 1225–1235, 2012.
- [3] J. M. Morales, A. J. Conejo, H. Madsen, P. Pinson, and M. Zugno, “Integrating renewables in electricity markets - operational problems,” *Springer*, vol. 205, p. 429, 2014.
- [4] Lawrence E Jones, *Renewable energy integration: practical management of variability, uncertainty and flexibility in power grids*, 1st ed. Boston: Academic Press, Elsevier, 2014.
- [5] E. Ela, B. Kirby, N. Navid, and J. C. Smith, “Effective ancillary services market designs on high wind power penetration systems,” in *IEEE Power and Energy Society General Meeting*, 2012, pp. 1–8.
- [6] J. Cochran, M. Miller, M. Milligan, E. Ela, D. Arent, A. Bloom, M. Futch, J. Kiviluoma, H. Holtinnen, A. Orths, E. Gómez-Lázaro, S. Martín-Martínez, S. Kukoda, G. Garcia, K. M. Mikkelsen, Z. Yongqiang, and K. Sandholt, “Market evolution: wholesale electricity market design for 21 st century power systems,” 2013.
- [7] H. Lund, *Renewable Energy Systems: A Smart Energy Systems Approach to the Choice and Modeling of 100% Renewable Solutions*, 2nd ed. Boston: Academic Press, Elsevier, 2014.
- [8] M. A. Islam, M. Hasanuzzaman, N. A. Rahim, A. Nahar, and M. Hosenuzzaman, “Global renewable energy-based electricity generation and smart grid system for energy security.,” *Sci. World J.*, vol. 2014, p. 13, 2014.
- [9] C. Harris, *Electricity Markets: Pricing, Structures and Economics*, vol. 565. John Wiley & Sons, 2011.
- [10] A. Ulian, M. Sebastian, G. Bartolucci, and C. Gutshi, “Business use cases definition and requirements,” *Deliverable D2.1, EU Project evolvDSO*, 2014. [Online]. Available: <http://www.evolvdsso.eu/Home/Results>.
- [11] A. I. Chrysochos, G. C. Kryonidis, E. O. Kontis, C. S. Demoulias, and G. K. Papagiannis, “Dynamic equivalent models for the simulation of controlled DRES,” *Deliverable D*, 2014. [Online]. Available: <http://www.project-increase.eu/index.php?cmd=s&id=74>.

- 
- [12] S. Delikaraoglou, "Harnessing and coordinating flexibility through market-based mechanisms," Technical University of Denmark, 2016.
- [13] F. Borggrefe and K. Neuhoff, "Balancing and intraday market design : Options for wind integration," *DIW Berlin Discuss. Pap. No. 1162*, pp. 1–30, 2011.
- [14] MIBEL, "Description of the operation of the MIBEL," 2009.
- [15] C. Weber, "Adequate intraday market design to enable the integration of wind energy into the European power systems," *Energy Policy*, vol. 38, no. 7, pp. 3155–3163, 2010.
- [16] CAISO, "Fifth replacement FERC electric tariff," 2011.
- [17] Energinet.dk, "Regulation C2 : The balancing market and balance settlement," 2008.
- [18] ENTSO-E, "Survey on ancillary services procurement , balancing market design 2015," 2016.
- [19] Z. Zhou, T. Levin, and G. Conzelmann, "Survey of U. S. ancillary services markets," 2016.
- [20] GWEC, "Global wind report - annual market update 2015," 2016.
- [21] C. Hiroux and M. Saguan, "Large-scale wind power in European electricity markets: time for revisiting support schemes and market designs?," *Energy Policy*, vol. 38, no. 7, pp. 3135–3145, Jul. 2010.
- [22] EC, "Communication from the commission - the support of electricity from renewable energy sources," European Commission, COM(2005) 627 final, 2005.
- [23] J. M. Morales, A. J. Conejo, K. Liu, and S. Member, "Pricing electricity in pools with wind producers," *IEEE Trans. Power Syst.*, vol. 27, no. 3, pp. 1366–1376, 2012.
- [24] D. Nock, V. Krishnan, and J. D. McCalley, "Dispatching intermittent wind resources for ancillary services via wind control and its impact on power system economics," *Renew. Energy*, vol. 71, pp. 396–400, 2014.
- [25] G. Michalke and A. D. Hansen, "Grid support capabilities of wind turbines," in *Handbook of Wind Power Systems*, Springer, 2014, pp. 569–590.
- [26] L. Zeni, A. J. Rudolph, J. Münster-Swendsen, I. Margaritis, A. D. Hansen, and P. Sørensen, "Virtual inertia for variable speed wind turbines," *Wind Energy*, vol. 16, pp. 1225–1239, 2013.
- [27] B. Kirby, M. Milligan, and E. Ela, "Providing minute-to-minute regulation from wind plants," *Annu. Large-Scale Integr. Wind Power into Power Syst. Transm. Networks Offshore Wind Power Plant*, no. October, 2010.
- [28] R. Doherty and M. O'Malley, "A new approach to quantify reserve demand in systems with significant installed wind capacity," *IEEE Trans. Power Syst.*, vol. 20, no. 2, pp. 587–595, 2005.
- [29] G. Pepermans, J. Driesen, D. Haeseldonckx, R. Belmans, and W. D'haeseleer, "Distributed generation: definition, benefits and issues," *Energy Policy*, vol. 33, no. 6, pp. 787–798, 2005.

- [30] R. Schleicher-Tappeser, "How renewables will change electricity markets in the next five years," *Energy Policy*, vol. 48, pp. 64–75, 2012.
- [31] P. Siano, "Demand response and smart grids - A survey," *Renew. Sustain. Energy Rev.*, vol. 30, pp. 461–478, 2014.
- [32] M. Braun, "Technological control capabilities of DER to provide future ancillary services," *Int. J. Distrib. Energy Resour.*, vol. 3, no. 3, pp. 191–206, 2007.
- [33] SWECO, "Study on the effective integration of demand energy recourses for providing flexibility to the electricity system," 2015. [Online]. Available: [https://ec.europa.eu/energy/sites/ener/files/documents/5469759000\\_Effective\\_integration\\_of\\_DER\\_Final\\_ver\\_2\\_6\\_April\\_2015.pdf](https://ec.europa.eu/energy/sites/ener/files/documents/5469759000_Effective_integration_of_DER_Final_ver_2_6_April_2015.pdf).
- [34] Eurelectric, "Flexibility and aggregation - requirements for their interaction in the market," 2014. [Online]. Available: [http://www.eurelectric.org/media/115877/tf\\_bal-agr\\_report\\_final\\_je\\_as-2014-030-0026-01-e.pdf](http://www.eurelectric.org/media/115877/tf_bal-agr_report_final_je_as-2014-030-0026-01-e.pdf).
- [35] L. M. Camarinha-Matos, "Collaborative smart grids ??? A survey on trends," *Renew. Sustain. Energy Rev.*, vol. 65, pp. 283–294, 2016.
- [36] R. Bayindir, I. Colak, G. Fulli, and K. Demirtas, "Smart grid technologies and applications," *Renew. Sustain. Energy Rev.*, vol. 66, pp. 499–516, 2016.
- [37] I. Colak, S. Sagiroglu, G. Fulli, M. Yesilbudak, and C. F. Covrig, "A survey on the critical issues in smart grid technologies," *Renew. Sustain. Energy Rev.*, vol. 54, pp. 396–405, 2016.
- [38] D. Bertsimas and J. N. Tsitsiklis, *Introduction to linear optimization*, 3rd ed. Belmont, Massachusetts: Athena Scientific, 1997.
- [39] D. G. Luenberger and Y. Ye, *Linear and nonlinear programming*, 3rd ed., vol. 116. Int. Ser. Oper. Res. Manag. Sci., New York: Springer US, 2008.
- [40] G. P. McCormick, "Computability of global solutions to factorable nonconvex programs: Part I - Convex underestimating problems," *Math. Program.*, vol. 10, no. 1, pp. 147–175, 1976.
- [41] M. Zugno, J. M. Morales, and H. Madsen, "Decision support tools for electricity retailers, wind power and CHP plants using probabilistic forecasts," *Int. J. Sustain. Energy Plan. Manag.*, vol. 7, pp. 17–33, 2015.
- [42] P. Rocha and D. Kuhn, "Multistage stochastic portfolio optimisation in deregulated electricity markets using linear decision rules," *Eur. J. Oper. Res.*, vol. 216, no. 2, pp. 397–408, 2012.
- [43] P. Kall and J. Mayer, *Stochastic linear programming: Models, theory, and computation*, vol. 80. Springer US, 2005.
- [44] D. Bertsimas, D. B. Brown, and C. Caramanis, "Theory and applications of robust optimization," *SIAM Rev.*, vol. 53, no. 3, pp. 464–501, 2011.
- [45] D. Kuhn, W. Wiesemann, and A. Georghiou, "Primal and dual linear decision rules in stochastic and robust optimization," *Math. Program.*, vol. 130, no. 1, pp. 177–209, 2011.
- [46] A. Georghiou, W. Wiesemann, and D. Kuhn, "Generalized decision rule

- approximations for stochastic programming via liftings,” *Math. Program.*, vol. 152, no. 1, pp. 301–338, 2015.
- [47] ILOG, “ILOG CPLEX 11.0 - user’s manual,” 2007.
- [48] A. Drud, *CONOPT: a system for large scale nonlinear optimization*. ARKI Consulting and Development A/S, 1996.
- [49] R. Rosenthal, *GAMS – a user’s guide*. Washington, DC: GAMS Development Corporation, 2008.
- [50] Roger Webster, *Convexity*. Oxford, England: Oxford Univeristy Press, 1995.
- [51] R. Tyrrell Rockafellar, *Convex analysis*. New Jersey, USA: Princeton University Press, 1997.
- [52] M. S. Bazaraa, H. D. Sherali, and C. M. Shetty, *Nonlinear programming: theory and algorithms*, 3rd ed. John Wiley & Sons, 2006.
- [53] A. Mitsos, B. Chachuat, and P. I. Barton, “McCormick-based relaxations of algorithms,” *Soc. Ind. Appl. Math.*, vol. 20, no. 2, pp. 573–601, 2009.
- [54] P. M. Castro, “Tightening piecewise McCormick relaxations for bilinear problems,” *Comput. Chem. Eng.*, vol. 72, pp. 300–311, 2015.
- [55] A. J. Conejo, M. Carrión, and J. M. Morales, *Decision making under uncertainty in electricity markets*, Internatio. Springer US, 2010.
- [56] Y. Guan and J. Wang, “Uncertainty sets for robust unit commitment,” *IEEE Trans. Power Syst.*, vol. 29, no. 3, pp. 1439–1440, 2014.
- [57] D. Bertsimas and M. Sim, “Robust discrete optimization under ellipsoidal uncertainty sets,” *Discret. Optim.*, pp. 1–23, 2004.
- [58] A. Ben-Tal and A. Nemirovski, “Robust convex optimization,” *Math. Oper. Res.*, vol. 23, no. 4, pp. 769–805, 1998.
- [59] D. Bertsimas and M. Sim, “Robust discrete optimization and network flows,” in *Mathematical Programming*, 2003, vol. 98, no. 1–3, pp. 49–71.
- [60] X. Chen, M. Sim, P. Sun, and J. W. Zhang, “A linear decision-based approximation approach to stochastic programming,” *Oper. Res.*, vol. 56, no. 2, pp. 344–357, 2008.
- [61] M. Zugno, J. M. Morales, and H. Madsen, “Robust management of combined heat and power systems via linear decision rules,” in *IEEE International Energy Conference (ENERGYCON)*, 2014, pp. 479–486.
- [62] F. Sioshansi, *Evolution of global electricity markets: New paradigms, new challenges, new approaches*, 1st ed. Boston: Academic Press, 2013.
- [63] H. Raiffa and R. Schlaifer, *Applied statistical decision theory*. Division of Research, Harvard Business School: Boston, 1961.
- [64] F. Beaudé, A. Atayi, J. Y. Bourmaud, D. Graeber, S. T. Schroder, P. E. Morthorst, L. Kitzing, M. Saguan, V. Rious, J. M. Glachant, E. Rivero Puente, T. Pagano, and A. Vafeas, “A modelling breakthrough for market design analysis to test massive intermittent generation integration in markets results of selected OPTIMATE studies,” in *10th International Conference on the European Energy*

- Market (EEM)*, 2013, pp. 1–8.
- [65] H. Holttinen, J. J. Miettinen, A. Couto, H. Algarvio, L. Rodrigues, and A. Estanqueiro, “Wind power producers in shorter gate closure markets and balancing markets,” in *13th International Conference on the European Energy Market (EEM)*, 2016, vol. 2016–July, pp. 1–5.
- [66] P. Pinson, C. Chevallier, and G. N. Kariniotakis, “Trading wind generation from short-term probabilistic forecasts of wind power,” *IEEE Trans. Power Syst.*, vol. 22, no. 3, pp. 1148–1156, Aug. 2007.
- [67] P. M. Morse and G. E. Kimball, *Methods of operations research*, 1st ed. Chapman and Hall, LTD, 1951.
- [68] F. Y. Edgeworth, “The mathematical theory of banking,” *J. R. Stat. Soc.*, vol. 51, pp. 113–127, 1888.
- [69] H. S. Lau and A. H. L. Lau, “The multi-product multi-constraint newsboy problem: applications, formulation and solution,” *Journal of Operations Management*, vol. 13, no. 2, pp. 153–162, 1995.
- [70] H. S. Lau and A. H. L. Lau, “The newsstand problem: a capacitated multiple-product single-period inventory problem,” *Eur. J. Oper. Res.*, vol. 94, no. 1, pp. 29–42, 1996.
- [71] Y. Wang, H. Bayem, M. Giralt-Devant, V. Silva, X. Guillaud, and B. Francois, “Methods for assessing available wind primary power reserve,” *IEEE Trans. Sustain. Energy*, vol. 6, no. 1, pp. 272–280, 2015.
- [72] L. Roald, S. Misra, S. Backhaus, M. Chertkov, and G. Andersson, “Optimal power flow with wind power control and limited expected risk of overloads,” in *19th Power systems computation Conf.*, 2016, pp. 1–7.
- [73] Energinet.dk, “Technical regulation 3.2.5 for wind power plants with a power output above 11 kW,” 2015.
- [74] EirGrid, “EirGrid Grid Code, version 6,” 2015.
- [75] M. Zugno, T. Jónsson, and P. Pinson, “Trading wind energy on the basis of probabilistic forecasts both of wind generation and of market quantities,” *Wind Energy*, vol. 16, no. 6, pp. 909–926, 2013.
- [76] B. Kirby and A. Tuohy, “Profitability of wind plants providing ancillary services - regulation and spinning reserve,” 2013. [Online]. Available: [http://www.nrel.gov/electricity/transmission/pdfs/wind\\_workshop2\\_24kirby.pdf](http://www.nrel.gov/electricity/transmission/pdfs/wind_workshop2_24kirby.pdf).
- [77] A. V. Santiago, “Strategic short-term model for the MIBEL electricity spot market,” Comillas Pontifical University, 2012.
- [78] Energinet.dk, “Wind power to combat climate change - how to integrate wind energy into the power system,” 2009.
- [79] E. Fanone, A. Gamba, and M. Prokopczuk, “The case of negative day-ahead electricity prices,” *Energy Econ.*, vol. 35, no. May 2008, pp. 22–34, Jan. 2013.
- [80] I. Praça, C. Ramos, Z. Vale, and M. Cordeiro, “MASCEM : A multiagent system that simulates competitive electricity markets,” *Intell. Syst. IEEE*, vol. 18, no. 6, pp. 54–60, 2003.



- 
- [81] T. Pinto, Z. Vale, T. M. Sousa, I. Praça, and H. Morais, “Adaptive learning in agents behaviour: a framework for electricity markets simulation,” *Integr. Comput. Aided. Eng.*, vol. 21, no. 4, pp. 399–415, 2014.
- [82] T. Pinto, H. Morais, P. Oliveira, Z. Vale, I. Praça, and C. Ramos, “A new approach for multi-agent coalition formation and management in the scope of electricity markets,” *Energy*, vol. 36, no. 8, pp. 5004–5015, 2011.
- [83] B. Teixeira, F. Silva, T. Pinto, I. Praça, G. Santos, and Z. Vale, “Data Mining Approach to support the Generation of Realistic Scenarios for Multi-Agent simulation of Electricity Markets,” in *Intelligent Agents (IA), 2014 IEEE Symposium on*, 2014, pp. 8–15.
- [84] A. Madureira, R. Bessa, J. Meirinhos, D. Fayzur, J. Filipe, A. A. Messias, D. A. Lopes, and P. G. Matos, “The impact of solar power forecast errors on voltage control in smart distribution grids,” in *23rd International Conference on Electricity Distribution (CIRED 2015), Lyon, France, 2015*.
- [85] D. Kirschen, R. Allan, and G. Strbac, “Contributions of individual generators to loads and flows,” *IEEE Trans. Power Syst.*, vol. 12, no. 1, pp. 52–60, 1997.
- [86] J. Bialek, “Topological generation and load distribution factors for supplement charge allocation in transmission open access,” *IEEE Trans. Power Syst.*, vol. 12, no. 3, pp. 1185–1193, 1997.
- [87] M. Shahidehpour, H. Yamin, and Z. Li, *Market Operations in Electric Power Systems : Forecasting, Scheduling, and Risk Management*, vol. 9. 2002.

Part II  
Papers



APPENDIX **A**

# Paper A

---

**Title:**

Cost allocation model for distribution networks considering high penetration of distributed energy resources

**Authors:**

Tiago Soares, Fábio Pereira, Hugo Morais and Zita Vale

**Published in:**

Electric Power Systems Research (2015), DOI: [dx.doi.org/10.1016/j.epsr.2015.03.008](https://doi.org/10.1016/j.epsr.2015.03.008).

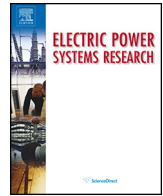

# Cost allocation model for distribution networks considering high penetration of distributed energy resources



Tiago Soares<sup>a,b</sup>, Fábio Pereira<sup>b</sup>, Hugo Morais<sup>b,c,\*</sup>, Zita Vale<sup>b</sup>

<sup>a</sup> Center for Electric Power and Energy, Department of Electrical Engineering, Technical University of Denmark (DTU), Elektrovej, Building 325, DK-2800 Kgs. Lyngby, Denmark

<sup>b</sup> GECAD – Knowledge Engineering and Decision Support Research Center of the Polytechnic of Porto (ISEP/IPP), R. Dr. António Bernardino de Almeida, 431, 4200-072 Porto, Portugal

<sup>c</sup> AUTomation and Control Group, Department of Electrical Engineering, Technical University of Denmark (DTU), Elektrovej, Building 326, DK-2800 Kgs. Lyngby, Denmark

## ARTICLE INFO

### Article history:

Received 6 October 2014

Received in revised form 11 February 2015

Accepted 8 March 2015

Available online 30 March 2015

### Keywords:

Bialek's tracing method

Distributed energy resources

Kirschen's tracing method

MW-mile

Network tariffs allocation

Topological distribution factors

## ABSTRACT

The high penetration of distributed energy resources (DER) in distribution networks and the competitive environment of electricity markets impose the use of new approaches in several domains. The network cost allocation, traditionally used in transmission networks, should be adapted and used in the distribution networks considering the specifications of the connected resources. The main goal is to develop a fairer methodology trying to distribute the distribution network use costs to all players which are using the network in each period. In this paper, a model considering different type of costs (fixed, losses, and congestion costs) is proposed comprising the use of a large set of DER, namely distributed generation (DG), demand response (DR) of direct load control type, energy storage systems (ESS), and electric vehicles with capability of discharging energy to the network, which is known as vehicle-to-grid (V2G). The proposed model includes three distinct phases of operation. The first phase of the model consists in an economic dispatch based on an AC optimal power flow (AC-OPF); in the second phase Kirschen's and Bialek's tracing algorithms are used and compared to evaluate the impact of each resource in the network. Finally, the MW-mile method is used in the third phase of the proposed model. A distribution network of 33 buses with large penetration of DER is used to illustrate the application of the proposed model.

© 2015 Elsevier B.V. All rights reserved.

## 1. Introduction

### 1.1. Background, methodology and aim

The design and development of cost allocation methods applied to users of transmission systems is a topic widely studied, resulting in several different methods for cost allocation. However, at the distribution system level, the cost allocation topic has been the target of deep study because its technical and operation characteristics are different from transmission systems requiring the development of new methodologies.

Traditionally, the operation costs in distribution systems are allocated to consumers connected in the network based on average

operation costs [1]. With the increasing penetration of distributed energy resources (DER) in distribution systems, the traditional cost allocation methods are no longer valid, due to different directions of power flow in distribution systems caused by DER [2]. Thus it is necessary to develop new methodologies more adequate for the new operation paradigm.

In fact, the actual power systems are no more characterized by a central generation units connected to transmission systems and a passive consumers most of them connected to medium and low voltage distribution networks. This operation paradigm has gradually changed to a more decentralized one. Nowadays, most of the power systems are characterized by the high penetration of distributed generation connected in all voltage levels, the existence of storage systems (pumped hydro power plants and few batteries based systems), the growing introduction of electric vehicles and the active participation of consumers through the demand response programs and a more conscience concerning the efficiency use of the energy. Taking this reality into account, the methods traditionally used to determine the costs allocation of the distribution

\* Corresponding author at: AUTomation and Control Group, Department of Electrical Engineering, Technical University of Denmark (DTU), Elektrovej, Building 326, DK-2800 Kgs. Lyngby, Denmark. Tel.: +351 228340500; fax: +351 228321159.  
E-mail address: [hmm.hugo@gmail.com](mailto:hmm.hugo@gmail.com) (H. Morais).

## Nomenclature

### Parameters

$\eta_c$	grid-to-storage/vehicle efficiency
$\eta_d$	storage/vehicle-to-grid efficiency
$B$	imaginary part in admittance matrix (S)
$c$	resource cost in period $t$ [m.u./kWh]
$DF$	pay factor used to determine the fixed costs allocation for each type of resource
$DN$	pay factor used to determine the network use costs allocation for each type of resource
$DL$	pay factor used to determine the system losses costs allocation for each type of resource
$E$	stored energy in the battery of storage system or vehicle at the end of period $t$ (kWh)
$E_{initial}$	energy stored in the battery of storage system or vehicle at the beginning of period 1 (kWh)
$E_{Trip}$	energy consumption in the battery during a trip that occurs in period $t$ (kWh)
$F$	branch power flow (kW)
$G$	real part in admittance matrix (S)
$L$	branch Losses (kW)
$LMP$	locational marginal price (m.u./kWh)
$N$	number of resources
$S$	apparent power flow in branch (kVA)
$T$	total number of periods
$X$	payment factor
$\bar{U}$	voltage in polar form (V)
$\bar{y}$	series admittance of line that connects two buses (S)
$\bar{y}_{sh}$	shunt admittance of line that connects two buses (S)

### Superscript

<i>Fixed</i>	fixed costs (m.u.)
<i>Loss</i>	losses costs (m.u.)
<i>NetUse</i>	network use costs (m.u.)

### Indices

$i, j$	node index
$dg$	distribution generation index
$sp$	external suppliers index
$st$	energy storage system index
$t$	time index in hours (h)
$v2g$	vehicle-to-grid index

### Variables

$\theta$	voltage angle
$C$	cost (m.u.)
$P$	active power (kW)
$Q$	reactive power (kVAr)
$TC$	total allocation cost (m.u.)
$V$	voltage magnitude (V)
$Y$	binary variable

### Subscript

$\psi$	inefficiency costs
$A$	fixed component of cost function (m.u./h)
$B$	linear component of cost function (m.u./kWh)
<i>Branch</i>	branch
$C$	quadratic component of cost function (m.u./kWh <sup>2</sup> )
$Ch$	storage or V2G charge process
$Dch$	storage or V2G discharge process
$DG$	distribution generation
$DR.A$	active power reduction of load
$DR.B$	active power curtailment of load

$GCP$	generation curtailment power
$Load$	loads
$LTC$	loads total cost
$Max$	upper bound limit
$Min$	lower bound limit
$NSD$	non-supplied demand
$SP$	external supplier
$V2G$	vehicle-to-grid

network, in which the consumers pay all the costs, are no more adequate. A new methodology is proposed in this paper for the costs allocation in distribution network, taking into account the new operation paradigm with large penetration of several types of DER. The main goal of the proposed method is to distribute the costs fairer to all players connected to the distribution networks taking into account the effective use of the network in each period (15, 30 or 60 min). As mentioned, the proposed methodology considers several types of DER, namely distributed generation (DG); direct load control demand response (DR); energy storage systems (ESS); and electric vehicles with the capability to charge and discharge energy, usually referred as vehicle-to-grid (V2G) resources.

The methodology considers the combination of three different cost allocation methods with the aim of take advantage of the main qualities of each one, to develop a more fairly cost allocation model. The methodology comprises three levels. The first level consists in the energy resources schedule optimization considering the merit order, in this case the operation cost. By considering an AC OPF it is also possible to obtain the locational marginal prices (LMP) in each bus, including the energy LMP, the losses LMP, and the congestion LMP (marginal method). The second level intends to determine the share/impact that each energy resource has on the network power flow (tracing method). Two different approaches based on the proportional sharing principle are tested and compared to determine the impact of each resource in the network. The third level consists in the application of allocation costs method to each type of resource (variant of MW-mile method).

### 1.2. Literature review and specific contributions

The cost allocation is a topic widely studied in transmission networks [3–24]. However, the increasing penetration of DER at distribution level forces the need to adapt traditional cost allocation methods used in transmission system to the distribution level. In general, the cost allocation methods for transmission systems may be classified into three distinct categories: nodal marginal methods [3–7]; rolled-in methods [8–11]; embedded-methods [12–24]. The cost allocation based on nodal marginal pricing for transmission systems is presented in [3–5], in which are considered the long-term and short-term marginal costs related to energy, reliability, investments and demand side. Similar approaches for distribution networks considering distributed generation are proposed in [6,7]. These approaches have some limitations. In [6] the tariff scheme only considers the consumers disregarding the generation units. In [7] the fixed costs scheme for demand and DG resources are considered but only for extreme scenarios.

The rolled-in methods are characterized by their easy implementation ensuring return on the total system operation costs. These methods allow getting a tariff based on the average cost of the system. The postage stamp [8,9], contract path [10], and

mean participation factors [11] are the most important rolled-in methods.

The embedded methods based on power flow analysis are characterized by the inclusion of network technical characteristics, resulting in a proper cost allocation method to each entity involved in the system. In this class, there are several cost allocation methods. The MW-mile [12] method is widely used in transmission networks, in which considers the changes in MW transmission flow and transmission line length in miles. Several other methods were developed based on MW-mile method, such as the unused capacity [13], the zero counter-flow [14], the dominant flow [15], and the MVA-mile [16]. Based on the power flow, the equivalent bilateral exchange method for cost allocation is proposed in [17]. In this method, it is considered that a portion of each generator, being the portion divided uniformly by all generators, supplies each load. Thus, each generator provides a portion of each load uniformly divided by all the loads of the system. The general agreement on parallel paths method [18] consists in a set of rules to reward the system operator considering the impact of each resource in the network. This method is based on getting parallel paths of the power flow when a single contract path between two parts is not good enough. Thus, the method considers an initial set of criteria and rules based on system reliability to perform parallel paths that are used to remunerate the system. The rated system path [19] is a method based on the study of the transmission capacity in the system. The transmission capacity is obtained by conducting several studies of the power flows, considering different situations of system operation which results in the cost allocation of the system. The *Zbus* method is based on circuit theory and it can determine how an injection of power of a given resource uses the network. Thus, it is possible to allocate the costs of network usage to the energy resources [20]. Others embedded cost allocation methods such as the generalized distribution factors [15], Bialek's [21], and Kirschen's [22] tracing algorithms are based on the definition of distribution factors in order to know the share that each user has in the network. An hybrid method called "Amp-mile" [23] combines the use of power flow distribution factors in order to know the impact that each user has on each network branch, with some characteristics of the MW-mile. A complete distinct approach based on game theory is proposed in [24], which allocates the cost of DG embedded distribution network based on Nucleolus and Shapley value approaches. For distribution systems a methodology considering Bialek's tracing algorithm to trace the power flow and a variant of MW-mile to tariff each resource use on the network is proposed by [25].

As it is possible to see by the large number of different techniques proposed in literature, the network costs allocation is a very important topic for power systems. However, most of the techniques were developed to be used at the transmission level considering a centralized generation approach and passive consumer's behavior. These traditional characteristics will change in future power systems. Furthermore, most of the techniques use different variants of MW-mile to tariff each resource without considering improvements on the efficiency of the method. The original MW-mile model presents some inefficient results as identified in [15]. The MW-mile inefficiency means that some costs are not allocated to any player. To avoid this inefficiency it is necessary develop some inefficiency compensation scheme improving the sustainability of the model as well as properly and fairly allocate the costs to all resources of the system. Moreover, future distribution systems will include several types of different generation and consumers resources, such as V2G resources. V2G resources increase the complexity of the distribution system management. The ability to be a consumer or a generation resource should be taken into account in order to properly allocate impact costs of this resource in the system. The main objective of the present work is to propose a

model able to properly and fairly allocate the distribution network operation costs to all players connected in this network. The main contributions of this paper are:

- (a) To propose a model to tariff distribution network use, considering large penetration of distributed energy resources, namely distributed generation, demand response, energy storage systems, and vehicle-to-grid.
- (b) To propose a model to cost allocation of storage base distributed resources, such as ESS and V2G, considering the ability act as a generator or as a consumer among time horizon.
- (c) To design a complete model able to take advantage of three different known cost allocation methods. Marginal method to obtain economic signals for network use and losses costs, tracing method to proportional determine the share for each type of resource, and a variant of MW-mile method to allocate costs to resources considering the marginal and tracing methods.
- (d) To implement, evaluate and compare two different methods of tracing power flow (Kirschen's and Bialek's tracing algorithms) considering future distribution network characteristics.
- (e) To integrate a new inefficiency penalty scheme to improve MW-mile method and the full sustainability of the model avoiding the existence of costs not allocated to any player.

### 1.3. Paper organization

The paper is structured as follows: Section 2 presents the detailed tariff model definition considering all the assumptions and features of the model; Section 3 illustrates the model operation in a distribution network considering the large penetration of DER; Section 4 exposes the most important conclusions.

## 2. Distribution network tariffs definition

The proposed methodology consists in three main steps represented in Fig. 1. The method starts by obtaining the locational marginal prices (LMP) [26–28] through an economic dispatch algorithm. Then is determined the network use by each energy resource based on distribution coefficients models. The last stage deals with the network allocation costs for each resource based on a variant of the MW-mile method. The combination of the advantages of three different methods leads to a more efficient, properly and fairly model to allocate distinct distribution network costs to all type of distributed energy resources.

### 2.1. First step – energy resources scheduling and locational marginal prices definition

To obtain locational marginal prices in each bus an economic dispatch algorithm is used to schedule the DER units connected to the distribution network, based on their operation cost and on the contracts established with these DER. The objective function has the main goal of minimizing operation costs of distribution system operator taking into account several types of DER. The DER considered in the present methodology are the distributed generation (DG), the active participation of consumers in direct load control demand response events (DR), electric vehicles with capacity to charge and discharge energy (V2G), and energy storage systems (ESS). Additionally, part of the power demand is supplied by external entities through the transmission network. These external entities are called external suppliers in this method. The external suppliers, represents the suppliers connected to upstream network levels of the distribution network that supply energy to satisfy the demand required in the distribution network. This energy can be bought in different markets sessions or in bilateral contracts. In

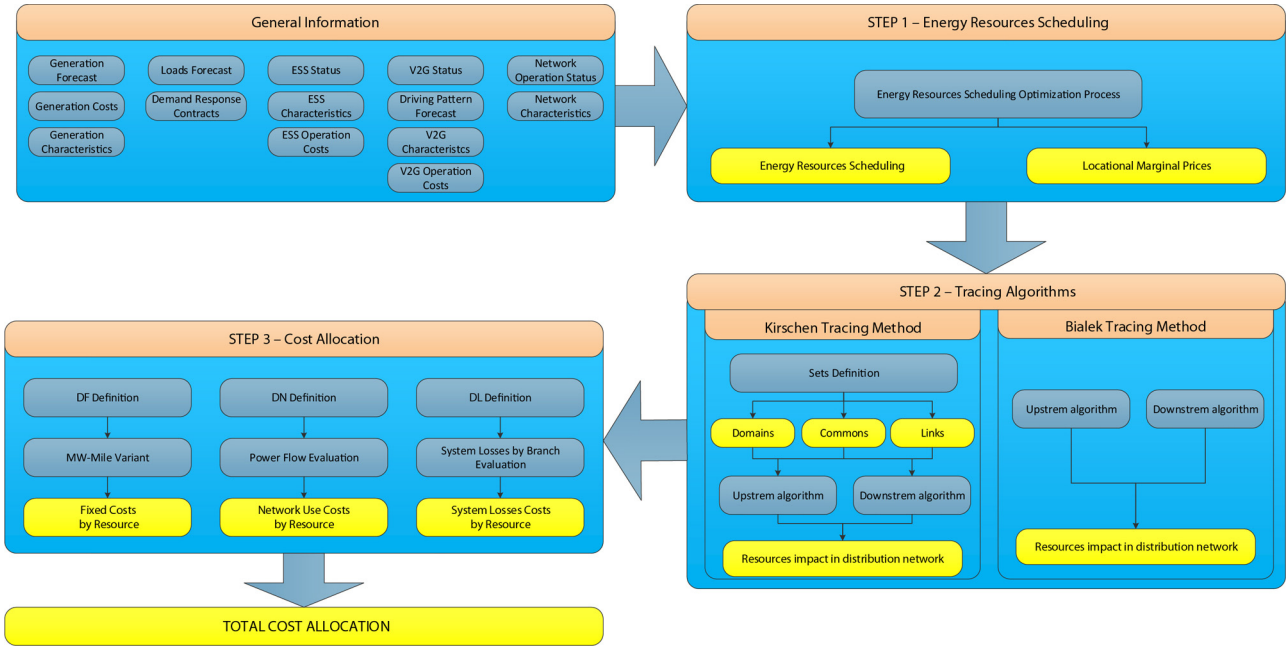

Fig. 1. Diagram of the proposed model.

a normal operation (without congestion situations and when the consumption is higher than the generation), the price of energy supplied by the external suppliers will impose the energy locational marginal price. However, some DER units have “feed-in” contracts imposing the delivery of all generated energy. In specific situations, such as when internal resources with “feed-in” contracts produce more energy than required, the energy LMP will be imposed by the price of these resources and not by the external suppliers. The energy resources scheduling can be solved as an optimization problem considering the minimization of the operation costs (1).

Minimize  $f = \min$

$$\sum_{t=1}^T \left[ \sum_{dg=1}^{N_{DG}} \left( B_{DG}(dg,t) \times c_{A}(dg,t) + P_{DG}(dg,t) \times c_{B}(dg,t) + P_{DG}^2(dg,t) \times c_{C}(dg,t) + P_{GCP}(dg,t) \times c_{GCP}(dg,t) \right) + \sum_{v2g=1}^{N_{V2G}} \left( P_{Dch}(v2g,t) \times c_{Dch}(v2g,t) - P_{Ch}(v2g,t) \times c_{Ch}(v2g,t) \right) + \sum_{l=1}^{N_L} \left( P_{DR\_A}(l,t) \times c_{DR\_A}(l,t) + P_{DR\_B}(l,t) \times c_{DR\_B}(l,t) + P_{NSD}(l,t) \times c_{NSD}(l,t) \right) + \sum_{st=1}^{N_{ST}} \left( P_{Dch}(st,t) \times c_{Dch}(st,t) - P_{Ch}(st,t) \times c_{Ch}(st,t) \right) + \sum_{sp=1}^{N_{SP}} P_{SP}(sp,t) \times c_{SP}(sp,t) \right] \quad (1)$$

The optimal energy resources scheduling includes several constraints related with the DER units and the distribution network [29]. An AC-OPF [30] is included to determine the active and reactive power that flows in each branch of the distribution system. Active balance (2) is determined based on all resources available in the system. Reactive balance (3) is determined considering only the resources able to provide reactive power as distributed generation and external suppliers. The AC-OPF determines the bus voltage magnitude (4) and voltage angles (5) taking into account the branch thermal limits (6) and (7). Besides AC-OPF constraints it is also considered technical constraints regarding the intrinsic characteristics of each type of resource (8)–(26). For external suppliers active (8) and reactive (9) limits of power delivery is considered. Distribution generators comprise active generation limits (10) and generation curtailment in active power (11), as well as reactive power (12). Demand reduction (13) and curtailment (14) through direct load control of demand response. Vehicle-to-grid resources will be an important resource in future distribution systems, but it increases the complexity of the problem (15)–(20). In this way, is essential to optimize the amount of energy stored (15) at the end

of each period in each V2G. To determine the amount of energy, it is usual to consider typical daily travel profile of each V2G as well as efficiency of charge and discharge energy in the grid. The energy stored on the battery of each V2G requires minimum (16) and maximum (17) limits. Charge (18) and discharge (19) rates present itself maximum limit. Charge and discharge energy for each V2G cannot occur at same time, so non-simultaneity of charge and discharge (20) is ensured. Technical constraints for energy storage systems (20)–(26) follow the same principle of constraints regarding V2G resources. The main difference between both resources is

that energy stored systems does not need reserve energy for travel, since they are not vehicles.

## 2.2. Second step – tracing algorithms

Based on the resources scheduling results and on the obtained LMPs, the second step of the proposed methodology aims to determine the contribution of each resource in the use of each network branch. In order to determine the resource contribution, two different techniques were implemented and tested. The first one is the Kirschen’s tracing method proposed in [22]. This technique defines the assumptions of domains, commons and links in order to determine the contribution of each resource in the network power flow. The second technique, called Bialek’s tracing method uses the topological distribution factors, which consider the proportional sharing of a network node assumption to determine the contribution of each resource in the network power flow [21]. Both techniques consider the proportional sharing principle.



Furthermore, the Bialek's tracing method uses two distinct algorithms (upstream and downstream-looking algorithms) in order to determine the impact of each generation and consumption resource in the network power flow.

Using these techniques to determine the impact that each resource has in each network branch is essential for the proper functioning of the proposed model. The model includes the use of these techniques in all types of DER in order to account the impact of such resources in a distribution system. DG, DR, ESS and V2G resources are considered in this model. Additionally, the loads are also considered as an active player in the cost allocation model. This means that in the proposed method the loads can be seen as an energy resource. Regarding the demand response programs, this resource is seen as a generation resource in the scheduling process, being considering the contracts costs. However, regarding the network use, the DR represents a load reduction. By taking this aspect into account, the DR is not included directly in the cost allocation problem, yet it is deducted from the load consumption. In practice, this means a negative cost due to the less load contribution in the cost distribution. In fact, the use of DR will improve the global system efficiency, at least during the DR use periods. The power flow caused by the load entity considers the difference between the initial energy required by the consumer, minus the power curtailed due to the participation on DR programs.

### 2.3. Kirschen's tracing method

The Kirschen's tracing method is a technique which aims to determine the impact that the generation and consumption resources have on the use of the distribution network. This technique is based on a set of definitions [22]:

- *Domains* – set of buses that are reached by power produced by particular generator.
- *Commons* – set of contiguous buses supplied by the same set of generators.
- *Links* – branches that connect with the commons.

This set of assumptions results in a simplification of the graphical structure of the network. Thus, it is used the proportional sharing principle to determine the share of each resource in each common, link, loads, and in the power flow of each common. This simplification may lead to imperfect results, especially when the network has a meshed structure and/or there is opposite power flow in the direction of the main flow of the system. Distribution networks are typically operated in radial mode and with unidirectional power flow. However, with high penetration of DER, the opposite power flows can occur in several periods throughout the day.

The method can be applied to all kinds of resources. However, there are two different algorithms (upstream and downstream-looking algorithms) that are used to trace the power for generation and consumption resources. The upstream-looking algorithm determines the share of generation resources, while the downstream-looking algorithm determines the impact of the consumption resources in the system.

### 2.4. Bialek's tracing algorithm

The Bialek's approach consists in the use of topological distribution factors in order to determine the share of the energy resources in the power system [21]. This method is based on the proportional share principle of power that considers the incoming flows and outflows in a node. This approach assumes that all topological distribution factors are positive, so the model is immune to counterflow problems in the branches that may occur

in networks with high DER penetration. Similar to the Kirschen's method, this technique also uses two tracing flow algorithms, upstream-looking algorithm to determine the share of generation resources, and downstream-looking algorithm to determine the share of consumption resources.

### 2.5. Third step – cost allocation

The cost allocation model corresponds to the last stage of the proposed methodology that is based on the MW-mile approach [12,15]. Indeed, this stage uses a variant of the MW-mile method proposed in [15] in order to allocate the system costs. The proposed MW-mile variant tends to be fairer to the resources than the traditional MW-mile approach. The proposed variant of MW-mile allocates the costs to the resource according to its impact in each network branch, while the traditional method uses the branch length or the total capacity of the branch. In addition, the proposed variant of MW-mile takes into account the previous stages of the model, where marginal and tracing methodologies are applied. Thus, the proposed cost allocation model for each resource comprises a combination of three different methods studied in literature.

This stage considers the allocation of three distinct kinds of costs for each resource based on the share of each resource in the system. The costs are divided into fixed, network use and losses costs. The total cost comprises the sum of the fixed, network use, and losses costs for each resource. The sum of each total cost results in the global allocation costs associated with the system.

$$\begin{aligned}
 TC_{(dg)} &= \sum_{i=1}^{N_B} \sum_{i=j}^{N_B} (C_{(i,j,dg)}^{Fixed} + C_{(i,j,dg)}^{NetUse} + C_{(i,j,dg)}^{Loss}) \\
 TC_{(l)} &= \sum_{i=1}^{N_B} \sum_{i=j}^{N_B} (C_{LTC(i,j,l)}^{Fixed} + C_{LTC(i,j,l)}^{NetUse} + C_{LTC(i,j,l)}^{Loss}) \\
 TC_{(v2g)} &= \sum_{i=1}^{N_B} \sum_{i=j}^{N_B} (C_{(i,j,v2g)}^{Fixed} + C_{(i,j,v2g)}^{NetUse} + C_{(i,j,v2g)}^{Loss}) \\
 TC_{(st)} &= \sum_{i=1}^{N_B} \sum_{i=j}^{N_B} (C_{(i,j,st)}^{Fixed} + C_{(i,j,st)}^{NetUse} + C_{(i,j,st)}^{Loss})
 \end{aligned} \tag{27}$$

### 2.6. Fixed costs

The fixed costs are related to the network operation and maintenance costs, as well as to the network initial investment costs. Contribution of DG in fixed costs of each branch is determined by knowing the power flow in branch, the contribution for DG in power flow of the branch, fixed cost of the branch and payment factor for DG units. The pay factor  $DF_{(i,j,dg)}$  is used to establish the contribution that each kind of resource has in fixed costs. The factor ranges from 0 to 1 and it is imposed by the distributed network operator based on strategic, political and environmental reasons. Similarly, the fixed costs for loads are allocated based on the same principle. The demand response programs will decrease the load consumption. Consequently, the payment fees applied to the loads will be reduced. This means an indirect incentive to increase consumers participation on these programs.

$$C_{(i,j,dg)}^{Fixed} = \frac{DF_{(i,j,dg)} \times C_{Branch(i,j)}^{Fixed}}{F_{(i,j)}} \times X_{DG} \tag{28}$$

Regarding the ESS and V2G resources, the principle to determine the fixed costs is similar to the DG resources. However, it is necessary to consider the charge and discharge capability of these resources. Therefore, the costs for charge and discharge must be

considered, based on the participation that charge and discharge ability has on network power flow.

$$C_{(i,j,v2g)}^{Fixed} = \left( \frac{DF_{Ch(i,j,v2g)} \times C_{Branch(i,j)}^{Fixed}}{F_{(i,j)}} + \frac{DF_{Dch(i,j,v2g)} \times C_{Branch(i,j)}^{Fixed}}{F_{(i,j)}} \right) \times X_{V2G} \quad (29)$$

The distribution of the payment factor for different kind of resources can lead to inefficiency in the total cost allocation of the system. The difference between the fixed costs of the branch and the sum of all costs determined for each resource will give the economic inefficiency of the model for that branch.

$$C_{\psi(i,j)}^{Fixed} = C_{Branch(i,j)}^{Fixed} - \left[ \sum_{dg=1}^{N_{DG}} C_{(i,j,dg)}^{Fixed} + \sum_{l=1}^{N_L} C_{(i,j,l)}^{Fixed} + \sum_{st=1}^{N_{ST}} C_{(i,j,st)}^{Fixed} + \sum_{v2g=1}^{N_{V2G}} C_{(i,j,v2g)}^{Fixed} \right] \quad (30)$$

This implies that the system operator cannot be fully refunded for the use of the system by the energy resources. In order to address the inefficiency in the distribution of the payment factors, it is assumed that the costs associated with the inefficiency will be supported by the loads entities. This means, an extra incentive to increase the consumption efficiency.

$$C_{LTC(i,j,l)}^{Fixed} = \frac{DF_{(i,j,l)}}{\sum_{l=1}^{N_L} DF_{(i,j,l)}} \times C_{\psi(i,j)}^{Fixed} + C_{(i,j,l)}^{Fixed} \quad (31)$$

## 2.7. Network use costs

The network use costs are associated, as the name suggests, with the use of network related to the power flow in each branch of the network, i.e., the costs are determined taking into account the impact of the power flow in each network branch. This cost is distributed among all resources (DG, ESS, V2G and loads) considering the impact of each one in the network. The network use cost by branch for distribution generation is determined based on DG payment factor with power flow on branch and total the cost of network use of the branch, while it is considered the distribution factor for DG  $DN_{(i,j,dg)}$ .  $DN$  factor is similar to the  $DF$  factor used to determine the fixed cost. The same value can be used for both.

$$C_{(i,j,dg)}^{NetUse} = \frac{DN_{(i,j,dg)} \times C_{Branch(i,j)}^{NetUse}}{F_{(i,j)}} \times X_{DG} \quad (32)$$

As for the fixed costs, for electric vehicles and storage systems, it is important to consider both the charge and discharge processes. Thus, it is considered charge and discharge distribution factors to determine the contribution of the electric vehicles in the network use costs. The same principle is applied for storage systems.

$$C_{(i,j,v2g)}^{NetUse} = \left[ \frac{DN_{Ch(i,j,v2g)} \times C_{Branch(i,j)}^{NetUse}}{F_{(i,j)}} \times \frac{DN_{Dch(i,j,v2g)} \times C_{Branch(i,j)}^{NetUse}}{F_{(i,j)}} \right] \times X_{V2G} \quad (33)$$

The cost  $C_{Branch(i,j)}^{NetUse}$  can be obtained considering the difference between the LMPs in the bus connected by the branch. In usual operation, the difference between LMP of each bus will reflect the LMP regarding the losses. However, in critical operation conditions with situations of congestion, the LMP's difference will also reflect the congestion LMP. In order to penalize the use of network near

by the boundaries,  $C_{Branch(i,j)}^{NetUse}$  can be determined as

$$\begin{cases} C_{Branch(i,j)}^{NetUse} = |LMP_{(j)} - LMP_{(i)}|; & \text{if } \frac{F_{(i,j)}}{F_{Max(i,j)}}(\%) \leq 85\% \\ C_{Branch(i,j)}^{NetUse} = 5 \times |LMP_{(j)} - LMP_{(i)}|; & \text{if } 85\% < \frac{F_{(i,j)}}{F_{Max(i,j)}}(\%) \leq 98\% \\ C_{Branch(i,j)}^{NetUse} = 10 \times |LMP_{(j)} - LMP_{(i)}|; & \text{if } \frac{F_{(i,j)}}{F_{Max(i,j)}}(\%) > 98\% \end{cases} \quad (34)$$

The main idea it is to penalize the use of the network near the boundaries. If the use of the network was higher than 85% of its capacity  $aS_{Max(i,j)}$ , the cost will be five times higher, if the use of the network was higher than 98%, the network use cost increases ten times. Thus, the resources are actively encouraged to contribute to system's efficiency.

As fixed costs, the method can lead to inefficiencies due to the mathematical rationality between distribution factor and payment factor. Thus, the costs of system inefficiency related to power flow costs can be determined as

$$C_{\psi(i,j)}^{NetUse} = C_{Branch(i,j)}^{NetUse} - \left[ \sum_{dg=1}^{N_{DG}} C_{(i,j,dg)}^{NetUse} + \sum_{l=1}^{N_L} C_{(i,j,l)}^{NetUse} + \sum_{st=1}^{N_{ST}} C_{(i,j,st)}^{NetUse} + \sum_{v2g=1}^{N_{V2G}} C_{(i,j,v2g)}^{NetUse} \right] \quad (35)$$

where the difference of the branch cost for network use and all the costs for network use by each type of resource results in inefficiency cost to be charged in order to maintain economic balance of system operator.

Moreover, the costs of system inefficiency related to the network use costs are allocated to the loads. Thus, total power flow costs for loads are determined taking into account the addition of inefficiency costs to the already cost for the use of the network.

$$C_{LTC(i,j,l)}^{PF} = \frac{DF_{(i,j,l)}}{\sum_{l=1}^{N_L} DF_{(i,j,l)}} \times (C_{\psi(i,j)}^{NetUse}) + (C_{(i,j,l)}^{NetUse}) \quad (36)$$

## 2.8. Losses costs

The system losses cost is allocated to each resource according to the impact that each one has on losses. The proposed methodology determines the share that each resource has in the branch losses by rating it according to the losses cost  $C_{Branch(i,j)}^{Loss}$  of each branch. The system losses cost in a branch is determined by multiplying the power losses in that line, obtained at step 1, by the higher LMP value in the buses connected to the branch. The contribution of distribution generators to the system losses is determined as

$$C_{(i,j,dg)}^{Loss} = \frac{DL_{(i,j,dg)} \times C_{Branch(i,j)}^{Loss}}{L_{(i,j)}} \times X_{DG} \quad (37)$$

where  $DL_{(i,j,dg)}$  is the distribution factor of distribution generation considering losses flow in branch  $ij$ , i.e., the contribution of DG unit to the losses in branch  $ij$ . For loads impact determination, similar assumptions are made. For electric vehicles and storage systems determination of losses costs are determined as

$$C_{(i,j,v2g)}^{Loss} = \left[ \frac{DL_{Ch(i,j,v2g)} \times C_{Branch(i,j)}^{Loss}}{L_{(i,j)}} \times \frac{DL_{Dch(i,j,v2g)} \times C_{Branch(i,j)}^{Loss}}{L_{(i,j)}} \right] \times X_{V2G} \quad (38)$$

where charge and discharge distribution factor for losses in each branch it is considered.

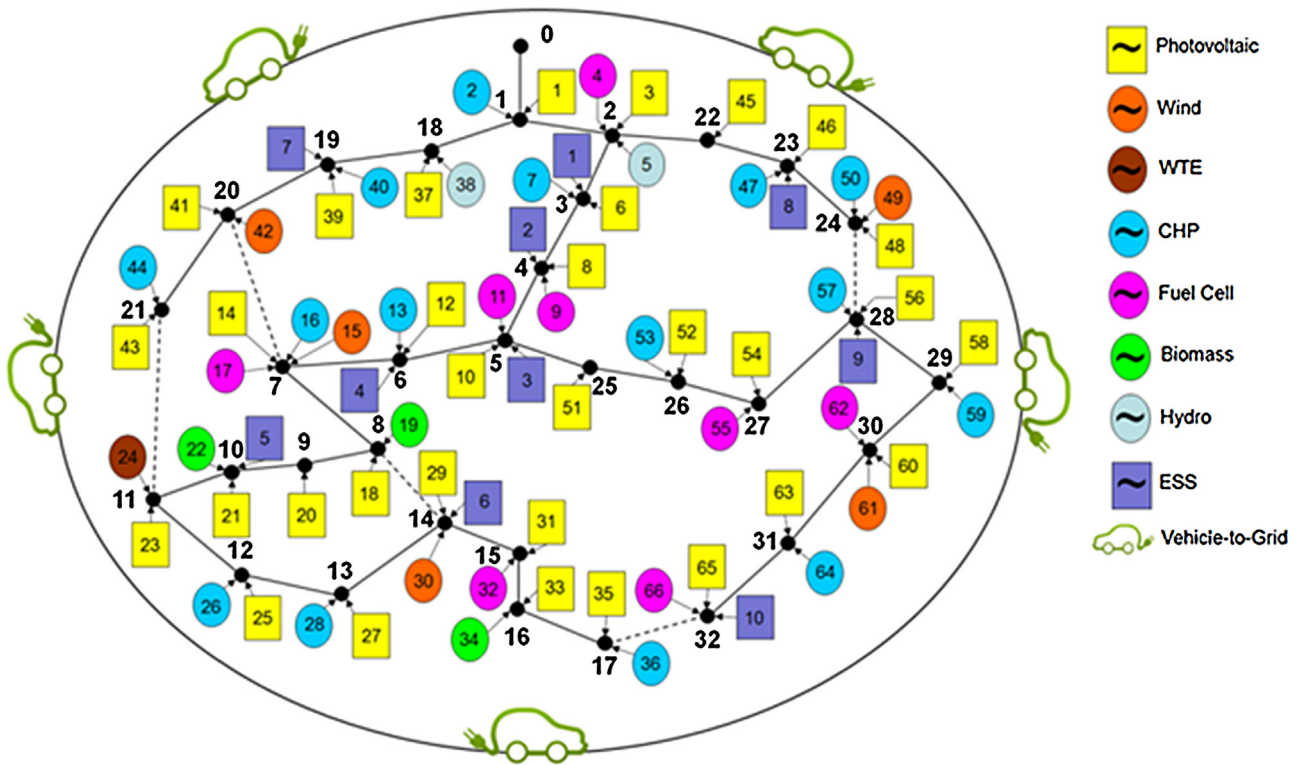

Fig. 2. Network configuration adapted from [31].

The losses costs related to the system inefficiency are given

$$C_{\psi(i,j)}^{Loss} = C_{Branch(i,j)}^{Loss} - \left[ \sum_{dg=1}^{N_{DG}} C_{(i,j,dg)}^{Loss} + \sum_{l=1}^{N_L} C_{(i,j,l)}^{Loss} + \sum_{st=1}^{N_{ST}} C_{(i,j,st)}^{Loss} + \sum_{v2g=1}^{N_{V2G}} C_{(i,j,v2g)}^{Loss} \right] \quad (39)$$

The inefficiency costs of the system are allocated to the load entity. In this way, the determination of the total losses cost for each load entity in the system is determined as

$$C_{LTC(i,j,l)}^{Loss} = \frac{DF_{(i,j,l)}}{\sum_{l=1}^{N_L} DF_{(i,j,l)}} \times C_{\psi(i,j)}^{Loss} + C_{(i,j,l)}^{Loss} \quad (40)$$

where total costs for load entities consider not only the impact of loads in system losses, but also inefficiency costs related to the system losses.

### 3. Case study

A case study considering the simulation of the proposed model based on a distribution system with large penetration of DER is described. The case study is divided into two sections – the case study characterization and the results analysis.

#### 3.1. Case characterization

The case study is conducted based on a distribution network with 33 buses [31], taking into account a scenario of high penetration of distributed energy resources [32], as shown in Fig. 2. The tested network includes 66 DG units with different generation technologies, namely 32 photovoltaic systems, 15 combined heat and power (CHP), 8 fuel cell systems, 5 wind turbines, 3 biomass plants, 2 small hydro, and 1 waste-to-energy (WTE) units. The network is connected to the transmission system through the bus 0. There are

32 consumption points throughout the network representing the medium/low voltage (MV/LV) power transformers. The consumers are aggregated at these consumption points. Similarly, demand response programs can be scheduled by consumption point and not directly by each consumer. Two types of loads are considered for DR participation, namely the continuous regulation loads, with capability of reducing the consumption, and the discrete loads (ON/OFF) that are used for load curtailment. The network contains 10 ESS and 50 V2G resources able to charge and discharge energy. The number of electric vehicles is relatively small, yet enough to evaluate the impact of this type of resource in the cost allocation methodology. The total generation capacity and the resources operation costs are presented in Table 1. In this table the ESS and V2G total storage capacity are also represented. The costs are applied in the discharge process and only consider the degradation costs of the batteries. The values are obtained considering the studies presented in [33,34].

The system operation costs should be allocated to each kind of resource. Currently, most of the system operators allocate all the costs related to the network tariffs to consumers. However, some system operators (such as the *Statnett SF* in Norway or the *NationalGrid* in the UK) allocate more than thirty percent of the costs to generators and less than seventy percent to consumers [35]. In the proposed approach, the costs are allocated by generation and consumption equally. However, inefficiency penalties are allocated only to the consumers (40). Additionally, in some periods, besides the generation and the consumption resources, the scheduling of storage and electric vehicles charge and/or discharge can occur. To take care of these different operation scenarios, a variable costs share is used. Table 2 shows the share in four possible operation scenarios.

Regarding fixed costs  $C_{Branch(i,j)}^{Fixed}$ , there is no information on investment, operation, and maintenance costs for the considered network. In this way, and based on the Portuguese energy authority (ERSE) [36] a percentage value of the system operation cost is considered. In the present case study, the average daily operation

**Table 1**  
Resources characteristics.

Resources	Installed/contracted capacity (kW)			Resources operation cost (m.u./kWh)		
	Minimum	Maximum	Total capacity	Minimum	Mean	Maximum
Photovoltaic	3	30	558	0.08000	0.13940	0.25400
Wind	20	150	525	0.05000	0.06520	0.08000
CHP	1	600	1200	0.00106	0.01790	0.06500
Biomass	100	150	350	0.06000	0.26530	0.65000
WTE	10	10	10	0.03000	0.04840	0.05600
Small hydro	30	40	70	0.03200	0.04320	0.04900
Fuel cell	10	50	235	0.09500	0.10210	0.11000
External supplier	–	–	15,000	0.01500	0.06050	0.21000
Reduce	7.15	250.19	834.83	0.10000	0.27270	0.80000
Cut	7.15	147.50	633.89	0.09000	0.49920	1.20000
ESS capacity (MWh)	–	–	1200	0.04500	0.05250	0.07000
V2G capacity (MWh)	–	–	7828	0.04500	0.05250	0.07000
Load	86.63	833.95	7245.20	–	–	–

**Table 2**  
Payment factor distribution.

Payment factor (%)	DG and external suppliers	Load	Storage	V2G
1	50.0	50.0	0.0	0.0
2	35.0	35.0	30.0	0.0
3	35.0	35.0	0.0	30.0
4	35.0	35.0	15.0	15.0

cost is of 16,000 monetary units (m.u.), and fifteen percent is considered corresponding a daily fixed costs of 2400 m.u., and 100 m.u. in each hour. These values can vary for different networks, and they can be higher in future smart grids due to the high investment in new control and protection equipment. However, the definition of these values is out of the scope of the present paper.

### 3.2. Results

The case study performs several results for each step of the model application. For first step it is performed an energy resource management of the distribution network with all resources included. The impact and contribution that each type of resource has on network power flow is shown in second step. Third step depicts all the costs allocated to each resource of the network, as well as the system remuneration for network use.

#### 3.2.1. Energy resources schedule results (first step)

The first step of the application model consists on energy resource management of the distribution network to perform scheduling for each resource and determine nodal prices in each node of the network. The energy schedule and nodal prices are the basis for the application tool. Thus, Fig. 3 presents the day-ahead scheduling, regarding the first step of the proposed methodology for 24 periods during the day. One can see in this figure the high impact of the DG throughout the day, ensuring around 35% of the energy requirements. The external suppliers are responsible for supplying around 61%, and the other resources ensure the remaining 4%. In fact, the ESS and V2G discharge, and mainly the DR programs only are used in very specific situations due to the higher use costs. In the present simulation scenario, a specific constraint in the external supplier's energy availability is imposed in periods 20–22 to force the use of these resources. This constraint allows the simulation of the proposed methodology considering different schedule scenarios, namely with high storage and V2G charge, with high storage and V2G discharge, with DR and considering only the loads and generators. Period 21 is the one with higher DER contribution.

The second output of the first step of the proposed methodology comprises the LMPs values in each bus. In fact, the LMPs are also different in each scheduling period resulting from different consumption/generation conditions. Due to the big diversity of the resources used, period 21 was selected for a more detailed evaluation. In Fig. 4 it is possible to see the LMP in each bus, as well as the obtained resources scheduled in each bus. Bus 0 is not considered in Fig. 4 as it is the upstream connection bus, in which the external suppliers are allocated. The external suppliers are the main suppliers of the network, and contribute with about 2229 kW, and a LMP of 0.21 m.u./kWh. By analysing the LMPs values it is possible to verify some steps in the LMPs curve resulting from the network topology. The difference in the LMPs results from losses in a more detailed evaluation it is also possible to see that the high generation in bus 26 provided by a CHP unit results in counterflow in the branch between buses 26 and 25. This phenomenon is reflected in the slope inversion of the LMP curve in bus 26.

#### 3.2.2. Tracing algorithms results (second step)

The second step of application model relates to the evaluation of the impact of each type of resource in the distribution network based on two different techniques for determination of network usage. The impact that each type of resource has on a given network branch for Kirschen's and Bialek's approaches are presented in Fig. 5, which corresponds to the second stage of the methodology. Fig. 5 depicts the impact of each type of resource in each network branch. The range of the gradient color is given between the white (without impact in the branch) and black (high impact in the branch). The maximum value is of 50% due to the adopted share values presented in Table 2. Additionally, Fig. 5 is split in four areas according the network topology, so it is easier to understand and evaluate. Through Fig. 5 one can identify that the load has a high network usage, which is expected due to the fact that in each node of the distribution system there are consumption resources. The Bialek's approach results in a larger impact of the load use in the network instead of the generation. On the other hand, the Kirschen's approach shows a larger distribution of the network usage by all the energy resources. It is also noteworthy that storage units and V2G resources have a greater impact on several branches of the network. This results are due to the Kirschen's approach be more simplified and less precise comparing to Bialek's approach. Thus, Kirschen's approach results in a wider distribution of the network usage, when the network tends to be meshed or if there are counterflows in the network. This aspect is more relevant in the branches between the buses 25–32.

In order to obtain a more detailed view of the proposed methodology, the resources impact in branch 11–12 are presented. This branch was selected based on the good participation of the

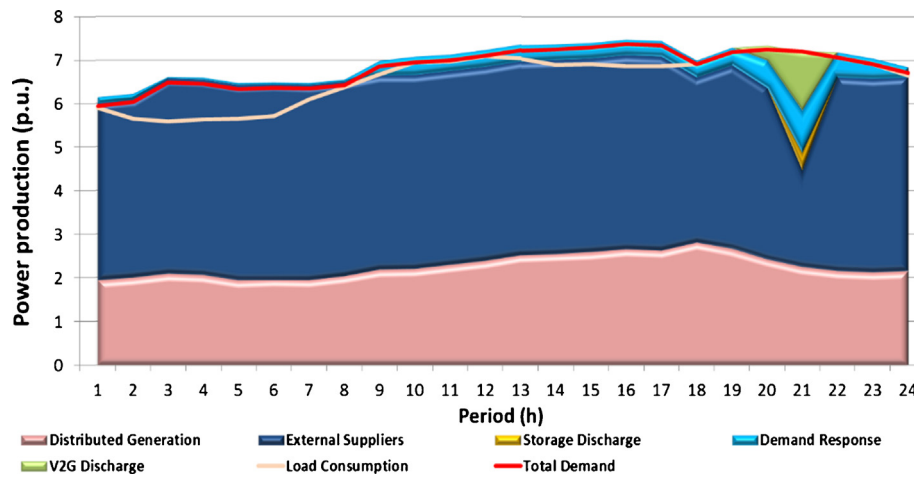

Fig. 3. Energy resources schedule in the distribution system.

different types of DER and because this branch has lower transmission capacity when compared to the remaining branches of the distribution system. Fig. 6 illustrates the share of different DER units in the power flow of branch 11-12. Moreover, it is possible to see the total costs (fixed, network use and system losses costs) that each resource has on the branch.

For the Bialek’s approach, the contribution of the DG and of the external supplier in the power flow of branch 11-12 is of about 55.4%, while the storage units and V2G have an impact of about 11.3% and 21.4%, respectively. The remaining part (11.9%) corresponds to the impact of loads in the branch. On the other hand, the DER participation by the Kirschen’s approach is significantly different. Thus, the DG contribution in the branch 11-12 is of about 38%, while the storage and V2G resources reaches 14.5% and 26%, respectively. The demand influence in the branch reaches to 21.5%. The DG with greater contribution in this branch corresponds to two biomass generation units that are connected closer to branch 11-12. The resource labeled as “Other DGs” corresponds to the impact of other DG units in this same branch. This portion is obtained based on the sum of all DG units with less impact in the branch. It is also possible to verify that the allocation costs follow the trend of the impact that each resource has in the network.

In general, the Bialek’s approach indicates a greater share of the DER in the branch power flow than the Kirschen’s approach. Regarding the V2G resources, the Kirschen’s approach tends to

spread the impact on the power flow through several units of V2G resources. This results in a uniform distribution of V2G by this approach.

3.2.3. Cost allocation results (third step)

The third step of application model is related to costs to be allocated to each resource ensuring the system economic sustainability. Each resource is charged for fixed, network use and losses costs. The results regarding the fixed, network use and systems losses costs are presented in Table 3. The results combine all the three different philosophies of allocation costs: (i) the marginal philosophy applied to define the network use and loss cost in each branch, (ii) tracing algorithms used to determine the share of each resource in the network use, and (iii) the MW-mile used to allocate the costs for each resource taking into account the previous methods. Thus, the results comprising the combination of the three different philosophies are presented. Furthermore, a comparison of the costs considering the Bialek’s and Kirschen’s tracing approaches is provided for a better understanding of the proposed model. The results are divided by each type of distributed energy resource, considering the loads and external suppliers. In a generalized way, the Kirschen’s approach assigns greater costs to generation resources, when compared with the Bialek’s approach. On the other hand, the opposite is verified for the consumption resources. Thus, the consumption resources have a major impact on the Bialek’s

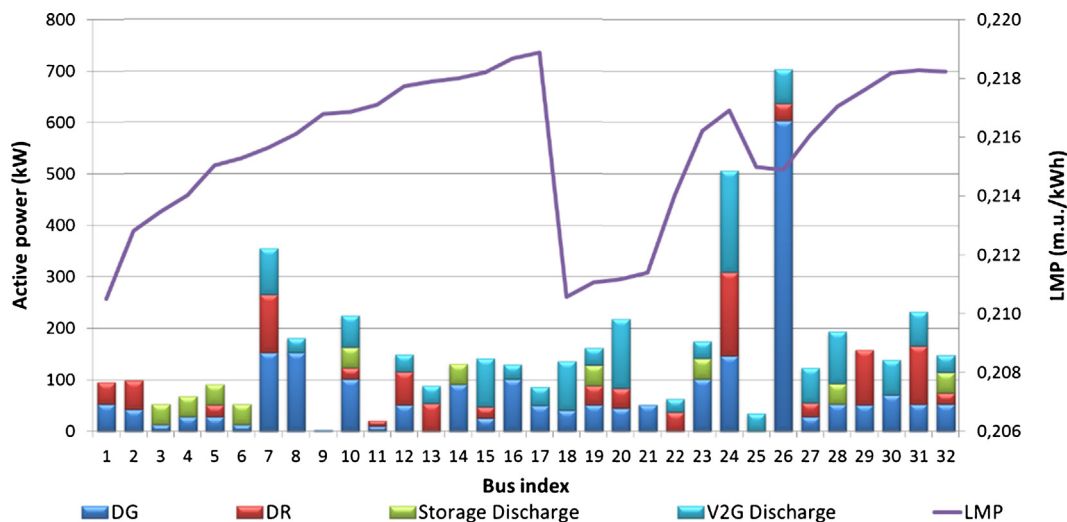
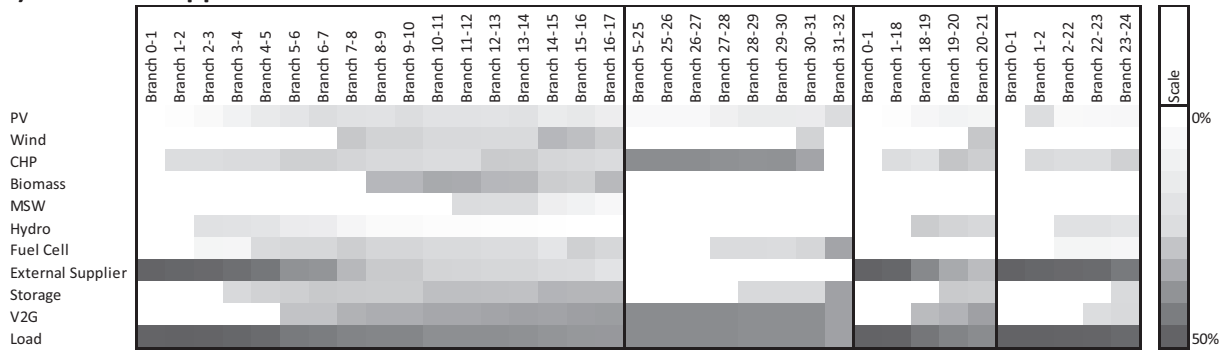

Fig. 4. Distributed energy resources dispatch and LMP by bus in period 21.



a) Kirschen’s Approach



b) Bialek’s Approach

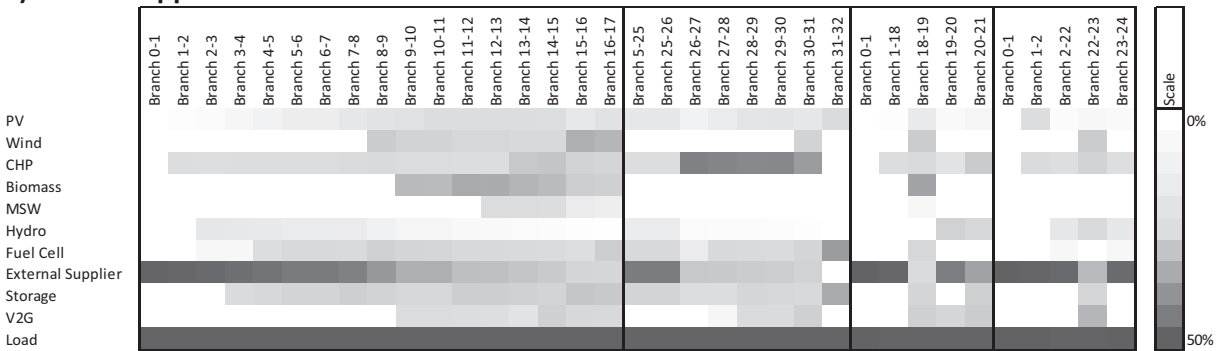

Fig. 5. Total DER impact in each branch in hour 21 considering Kirschen's and Bialek's approaches.

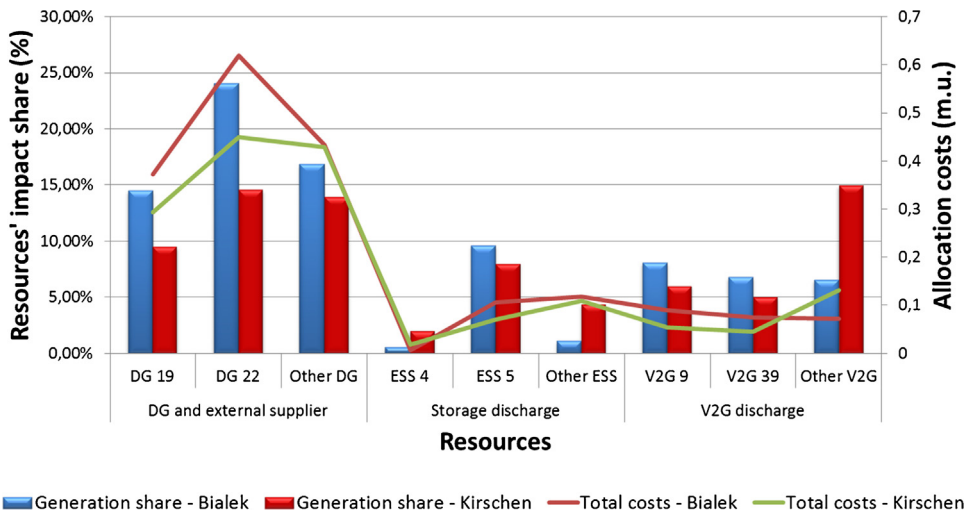

Fig. 6. Contribution of generation resources for branch 11-12 use in period 21.

methodology than in Kirschen's. On average, the Bialek's approach allocates 70.1% of the system costs to the consumption resources, while the Kirschen's approach reaches 54.3%. These differences result from the intrinsic characteristics and considerations of each approach, which are compounded with the penalty cost of the system's inefficiency for the consumption resources. This means that the Bialek's approach is more accurate to determine the impact of each resource in the network, yet it leads to an efficiency penalization factor in the cost allocation.

In both approaches, consumers and external supplier are the main users of the network, so they have the largest share of the total costs – 70.1% and 12.2% for Bialek's, and 54.3% and 14.5% for Kirschen's, respectively. The V2G resources take 2.78% and 7.76% of the total costs for Bialek's and Kirschen's approaches. This

indicates a considerable share of these resources in the network costs, especially in Kirschen's approach.

Fig. 7 illustrates the total allocation costs for each kind of resource in each network branch considering the Bialek's and Kirschen's approaches for hour 21. The external supplier is one of the bigger providers of the network. This influence is more important in branches closer to the upstream interconnection bus. On the other hand, the DER has major influence in the more distant branches.

Fig. 7(a) depicts the costs allocated to the energy resources for each branch of the distribution system, considering the Kirschen's tracing method. On average, the contribution of V2G resources in the branches of the distribution system is of about 17%. The highest concentration of costs for V2G occurs in branch 26-27, while

**Table 3**  
Distribution costs allocated to DER and load.

Resources	Bialek's approach				Kirschen's approach			
	Fixed cost (m.u./h)	Power flow cost (m.u./h)	Loss cost (m.u./h)	Total costs (m.u./h)	Fixed cost (m.u./h)	Power flow cost (m.u./h)	Loss cost (m.u./h)	Total costs (m.u./h)
Photovoltaic	0.3236	0.0002	0.0197	0.3435	0.4844	0.0003	0.0281	0.5128
Wind	1.6908	0.0008	0.1176	1.8092	2.6839	0.0014	0.1866	2.8719
CHP	6.8843	0.0055	0.3546	7.2445	9.5124	0.0072	0.5095	10.0291
Biomass	3.0130	0.0016	0.2099	3.2246	4.5083	0.0023	0.3143	4.8249
WTE	0.1020	0.0001	0.0071	0.1091	0.1364	0.0001	0.0095	0.1460
Small hydro	0.3584	0.0003	0.0244	0.3831	0.5761	0.0004	0.0391	0.6156
Fuel cell	1.4779	0.0008	0.0727	1.5514	2.5776	0.0011	0.1075	2.6862
External supplier	12.2229	0.0168	0.8363	13.0760	14.5209	0.0182	0.9941	15.5332
Storage discharge	1.0258	0.0005	0.0608	1.0871	2.8940	0.0013	0.1685	3.0639
Storage charge	0.0000	0.0000	0.0000	0.0000	0.0000	0.0000	0.0000	0.0000
V2G discharge	2.7801	0.0015	0.1720	2.9536	7.7563	0.0049	0.4646	8.2258
V2G charge	0.0000	0.0000	0.0000	0.0000	0.0000	0.0000	0.0000	0.0000
Load	70.1213	0.3826	5.0270	75.5308	54.3497	0.3736	4.0801	58.8034
Total	100.0000	0.4107	6.9021	107.3129	100.0000	0.4108	6.9019	107.3128

**a) Kirschen's Approach**

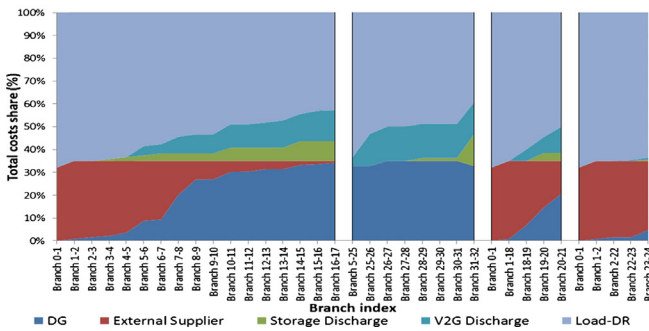

**b) Bialek's Approach**

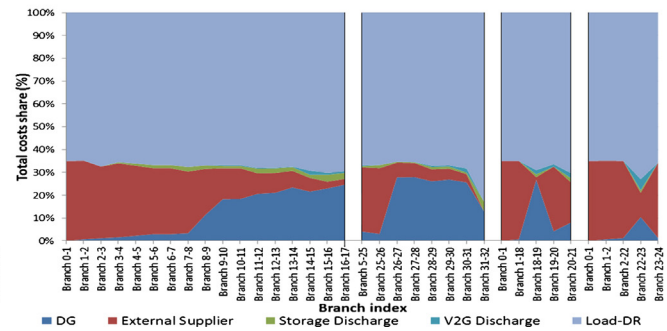

**Fig. 7.** Total costs in each branch by resource considering Kirschen's and Bialek's approaches in period 21.

for storage units it occurs in branch 31–32, and branch 27–28 for DG resources. Regarding the Bialek's approach, Fig. 7(b), on average, DG, storage and V2G have 46.1%, 3.4% and 9.3% of the total costs in the network related to generation resources, and the peak contribution is in branch 26–27, 31–32 and 20–21, respectively.

The results presented by Kirschen's and Bialek's approaches have some similarities. By comparing Fig. 7(a) and (b), it is possible to verify that the costs allocated to external suppliers in the branches closer to the upstream connection are similar. Furthermore, it seems that the DER allocation costs are higher in Fig. 7(a), which results from a lower cost allocation to the loads.

#### 4. Conclusions and discussion

The main motivation behind this work is to argue for the proposal of adaption and or develop new methodologies to cost allocate and critically analyze DER in future distribution systems. In this work is proposed a methodology able to consider all types of DER in the scope of the distribution networks. The model is a hybrid methodology that uses an economic dispatch problem, Kirschen's and Bialek's tracing approaches and a variant of the MW-mile method to allocate costs to all energy resources connected to the distribution network. The model is able to determine the contribution that each resource has in each branch of the network through Kirschen's and Bialek's tracing methods, as well as to allocate different types of costs according to the LMP of each bus and based on a variant of the MW-mile method. In this way, the model provides a comparison between Kirschen's and Bialek's approaches in order to highlight the importance and impact of different approaches to

the problem of tariffs allocation definition in distribution systems. In addition, it is noteworthy that Bialek's technique is more accurate in determining distribution factors than Kirschen's technique. Although both approaches are based on proportional sharing concept, Kirschen's technique use a simplified way to determine distribution factors, which is not so efficient as Bialek's technique for meshed networks and or with network counterflows.

Afterwards, the model proposes the use of three different types of costs, namely the fixed, network use and losses costs, to tariff resources and ensure network sustainability. Moreover, the model considers different tariffs approaches for each type of resource (namely, DG, DR, ESS, V2G and loads resources) taking into account their intrinsic characteristics. The two applied tracing techniques (Kirschen's and Bialek's) have different considerations for allocation costs. The contribution of each energy resource is different, resulting in different allocation costs. However, the introduction, conception and design of inefficiency penalty strategy cover the limitations of both methodologies. In this way, the overall results cover the total cost of the system operator for the network usage. Inefficiency strategy schemes for improvement of DER participation and incentive in the energy scheduled may lead to a new challenge in the way that allocation costs are spread through all types of resources. In addition, the model has the ability to adapt to different network conditions. Different network configuration and resources management leads to different results, since the model considers the integration of power flow and locational marginal costs allowing the evaluation of the network's use and to determine the allocation costs. Indeed, the proposed methodology only considers the resources that are scheduled in the first step and then fairly allocate the costs according to the network use by each

resource. Thus, the methodology adapts itself to the network conditions in each period to fairly allocate the costs.

The use of the proposed methodology allows reaching a number of practical conclusions. The most important ones relate to (i) the adaption of tracing algorithms (usually used on transmission systems) to distribution systems with future characteristics, (ii) the noteworthy improvement of use a variant of MW-mile to cost allocate different types of resources, (iii) the impact of different types of costs in distribution system operator revenue, (iv) increasing the efficiency of the model based on a penalty scheme ensuring system operator sustainability, (v) fairer distribution of allocation costs for all types of resources, including emerging resources, and (vi) easy adaption of the model to different network conditions.

The results support our expectations such that the model is quite diverse and able to cover several allocation costs methodologies to different types of resources. Moreover, the model effectively solves the cost allocation problem and it is illustrated by the case study considering different DER scheduling contexts.

These several conclusions are of particular relevance for several entities in electrical power systems, such as distribution operators to fair allocate all costs related to network usage, and to resources and retailers entities to simulate and evaluate its costs in network usage.

Future developments will focus on the possibility of use optimal power flow methods to deal with the unbalance on distribution networks. Finally, it will be of particular interest to analyze real-large networks with high penetration of distributed energy resources.

### Acknowledgments

This work is supported by FEDER Funds through COMPETE program and by National Funds through FCT under the projects FCOMP-01-0124-FEDER: PEst-OE/EEI/UI0760/2014, and by the GID-MicroRede, project no. 34086, co-funded by COMPETE under FEDER via QREN Programme. The present work is also developed under the EUREKA – ITEA2 Project SEAS with project number 12004. Tiago Soares is partly supported by the Technical University of Denmark through a Ph.D. grant, as well as by Danish Council for strategic Research through the “5s – Future Electricity Markets” project (no. 12-132636/DSF).

### Appendix A.

$$\begin{aligned} & \sum_{dg=1}^{N_{DG}^i} (P_{DG}^i(dg,t) - P_{GCP}^i(dg,t)) + \sum_{sp=1}^{N_{SP}^i} P_{SP}^i(sp,t) \\ & + \sum_{v2g=1}^{N_{V2G}^i} (P_{Dch}^i(v2g,t) - P_{Ch}^i(v2g,t)) + \sum_{st=1}^{N_{ST}^i} (P_{Dch}^i(st,t) - P_{Ch}^i(st,t)) \\ & - \sum_{l=1}^{N_L^i} (P_{Load}^i(l,t) - P_{NSD}^i(l,t) - P_{DR\_A}^i(l,t) - P_{DR\_B}^i(l,t)) \\ & = G_{ii} \times V_{i(t)}^2 + V_{i(t)} \times \sum_{j \in L^i} V_{j(t)} \times (G_{ij} \cos \theta_{ij(t)} + B_{ij} \sin \theta_{ij(t)}) \end{aligned} \quad (2)$$

$$\begin{aligned} & \sum_{dg=1}^{N_{DG}^i} Q_{DG}^i(dg,t) + \sum_{sp=1}^{N_{SP}^i} Q_{SP}^i(sp,t) - \sum_{l=1}^{N_L^i} (Q_{Load}^i(l,t) - Q_{NSD}^i(l,t)) \\ & = V_{i(t)} \times \sum_{j \in L^i} V_{j(t)} \times (G_{ij} \sin \theta_{ij(t)} - B_{ij} \cos \theta_{ij(t)}) - B_{ii} \times V_{i(t)}^2 \\ & \forall t \in \{1, \dots, T\}; \forall i \in \{1, \dots, N_B\}; \theta_{ij(t)} = \theta_{i(t)} - \theta_{j(t)} \end{aligned} \quad (3)$$

$$V_{Min}^i \leq V_{i(t)} \leq V_{Max}^i \quad (4)$$

$$\theta_{Min}^i \leq \theta_{i(t)} \leq \theta_{Max}^i \quad (5)$$

$$\left| U_{i(t)}^- \times [\bar{y}_{ij} \times (U_{i(t)}^- - U_{j(t)}^-) + y_{sh\_i} \times U_{i(t)}^-]^* \right| \leq S_{Branch(i,j)}^{Max} \quad (6)$$

$$\begin{aligned} & \left| U_{j(t)}^- \times [\bar{y}_{ij} \times (U_{j(t)}^- - U_{i(t)}^-) + y_{sh\_j} \times U_{j(t)}^-]^* \right| \leq S_{Branch(i,j)}^{Max} \\ & \forall t \in \{1, \dots, T\}; \forall i, j \in \{1, \dots, N_B\}; i \neq j; \forall k \in \{1, \dots, N_K\} \end{aligned} \quad (7)$$

$$0 \leq P_{SP}(sp,t) \leq P_{Max}(sp,t) \quad (8)$$

$$0 \leq Q_{SP}(sp,t) \leq Q_{Max}(sp,t) \quad (9)$$

$$P_{Min}(dg,t) \times Y_{DG}(dg,t) \leq P_{DG}(dg,t) \leq P_{Max}(dg,t) \times Y_{DG}(dg,t) \quad (10)$$

$$P_{DG}(dg,t) + P_{GCP}(dg,t) \leq P_{Max}(dg,t) \times Y_{DG}(dg,t) \quad (11)$$

$$\begin{aligned} & Q_{Min}(dg,t) \times Y_{DG}(dg,t) \leq Q_{DG}(dg,t) \leq Q_{Max}(dg,t) \times Y_{DG}(dg,t) \\ & \forall t \in \{1, \dots, T\}; \forall dg \in \{1, \dots, N_{dg}\} \end{aligned} \quad (12)$$

$$P_{DR\_A}(l,t) \leq P_{DR\_A;Max}(l,t) \quad (13)$$

$$P_{DR\_B}(l,t) = P_{DR\_B;Max}(l,t) \times Y_{DR\_B}(l,t) \quad (14)$$

$$\begin{aligned} & E_{Stored}(v2g,t) = E_{Stored}(v2g,t-1) - E_{Trip}(v2g,t) + \eta_c(v2g) \times P_{Ch}(v2g,t) \\ & - \frac{1}{\eta_d(v2g)} \times P_{Dch}(v2g,t) \quad \forall t \in \{1, \dots, T\}; \forall v2g \in \{1, \dots, N_{V2G}\}; \\ & \Delta t = 1; t = 1 \rightarrow E_{Stored}(v2g,t-1) = E_{Initial}(v2g) \end{aligned} \quad (15)$$

$$E_{Stored}(v2g,t) \geq E_{BatMin}(v2g,t) \quad (16)$$

$$E_{Stored}(v2g,t) \leq E_{BatMax}(v2g,t) \quad (17)$$

$$P_{Ch}(v2g,t) \leq P_{Max}(v2g,t) \times Y_{Ch}(v2g,t) \quad (18)$$

$$P_{Dch}(v2g,t) \leq P_{Max}(v2g,t) \times Y_{Dch}(v2g,t) \quad (19)$$

$$Y_{Ch}(v2g,t) + Y_{Dch}(v2g,t) \leq 1; \quad Y_{Ch}(v2g,t) \quad \text{and} \quad Y_{Dch}(v2g,t) \in \{0, 1\} \quad (20)$$

$$\begin{aligned} & E_{Stored}(st,t) = E_{Stored}(st,t-1) + \eta_c(st) \times P_{Ch}(st,t) - \frac{1}{\eta_d(st)} \times P_{Dch}(st,t) \\ & \forall t \in \{1, \dots, T\}; \forall st \in \{1, \dots, N_{ST}\}; \Delta \\ & t = 1; \quad t = 1 \rightarrow E_{Stored}(st,t-1) = E_{Initial}(st) \end{aligned} \quad (21)$$

$$E_{Stored}(st,t) \geq E_{BatMin}(st,t) \quad (22)$$

$$E_{Stored}(st,t) \leq E_{BatMax}(st,t) \quad (23)$$

$$P_{Ch}(st,t) \leq P_{Max}(st,t) \times Y_{Ch}(st,t) \quad (24)$$

$$P_{Dch}(st,t) \leq P_{Max}(st,t) \times Y_{Dch}(st,t) \quad (25)$$

$$Y_{Ch}(st,t) + Y_{Dch}(st,t) \leq 1; \quad Y_{Ch}(st,t) \quad \text{and} \quad Y_{Dch}(st,t) \in \{0, 1\} \quad (26)$$

### References

- [1] P.M. De Oliveira-De Jesus, M.T. Ponce de Leão, J.M. Yusta-Loyo, H.M. Khodr, Cost allocation in distribution networks with high penetration of distributed renewable generation – a comparative study, in: International Conference on Renewable Energies and Power Quality, March, Zaragoza, Spain, 2005.
- [2] A.A. Abou El Ela, R.A. El-Sehiemy, Transmission usage cost allocation schemes, *Electr. Power Syst. Res.* 79 (6) (2009) 926–936.
- [3] A. Bakirtzis, P. Biskas, A. Maïssis, A. Coronides, J. Kabouris, M. Efstathiou, Comparison of two methods for long-run marginal cost-based transmission use-of-system pricing, *IEEE Proc. Gener. Transm. Distrib.* 148 (2001) 477–481.



- [4] R.E. Rotoras, T. Lefevre, R.B. Pacudan, Marginal transmission pricing and supplemental cost allocation method: a case of Philippines, *Electr. Power Syst. Res.* 63 (2002).
- [5] M. Murali, M.S. Kumari, M. Sydulu, A comparison of fixed cost based transmission pricing methods, *Electr. Electron. Eng.* 1 (2011) 33–41.
- [6] P.M.D.O.D. Jesus, M.T.P. de Leao, J.M. Yusta, H.M. Khodr, A.J. Urdaneta, Uniform marginal pricing for the remuneration of distribution networks, *IEEE Trans. Power Syst.* 20 (2005) 1302–1310.
- [7] J. Mutale, G. Strbac, D. Pudjianto, Methodology for cost reflective pricing of distribution networks with distributed generation, in: *IEEE Power Engineering Society General Meeting*, 2007, 2007, pp. 1–5.
- [8] D. Shirmohammadi, X.V. Filho, B. Gorenstin, M.V.P. Pereira, Some fundamental, technical concepts about cost based transmission pricing, *IEEE Trans. Power Syst.* 11 (1996) 1002–1008.
- [9] P. Van Roy, T. Van Craenenbroeck, R. Belmans, D. Van Dommelen, G. Pepermans, S. Proost, Comparison of transmission tariff methods in a free market for electricity, in: *International Conference on Electric Power Engineering*, 1999, PowerTech Budapest 99, 1999, p. 159.
- [10] H.H. Happ, Cost of wheeling methodologies, *IEEE Trans. Power Syst.* 9 (1994) 147–156.
- [11] F.J. Rubio-Oderiz, I.J. Perez-Arriaga, Marginal pricing of transmission services: a comparative analysis of network cost allocation methods, *IEEE Trans. Power Syst.* 15 (2000) 448–454.
- [12] D. Shirmohammadi, P.R. Gribik, E.T.K. Law, J.H. Malinowski, R.E. O'Donnell, Evaluation of transmission network capacity use for wheeling transactions, *IEEE Trans. Power Syst.* 4 (1989) 1405–1413.
- [13] R.R. Kovacs, A.L. Leverett, A load flow based method for calculating embedded, incremental and marginal cost of transmission capacity, *IEEE Trans. Power Syst.* 9 (1994) 272–278.
- [14] J.W.M. Lima, Allocation of transmission fixed charges: an overview, *IEEE Trans. Power Syst.* 11 (1996) 1409–1418.
- [15] M. Shahidehpour, H. Yamin, Z. Li, Market overview in electric power systems, in: *Market Operations in Electric Power Systems*, Wiley-IEEE Press, 2002, pp. 1–20.
- [16] P. Jiuping, Y. Teklu, S. Rahman, J. Koda, Review of usage-based transmission cost allocation methods under open access, *IEEE Trans. Power Syst.* 15 (2000) 1218–1224.
- [17] F.D. Galiana, A.J. Conejo, H.A. Gil, Transmission network cost allocation based on equivalent bilateral exchanges, *IEEE Trans. Power Syst.* 18 (2003) 1425–1431.
- [18] S.M. Harvey, W.W. Hogan, S.L. Pope, Transmission Capacity Reservations and Transmission Congestion Contracts, FERC – Federal Energy Regulatory Commission, 1997.
- [19] FERC – Federal Energy Regulatory Commission, Rated System Path Methodology, 2007.
- [20] A.J. Conejo, J. Contreras, D.A. Lima, A. Padilha-Feltrin, Z.bus – transmission network cost allocation, *IEEE Trans. Power Syst.* 22 (2007) 342–349.
- [21] J. Bialek, Topological generation and load distribution factors for supplement charge allocation in transmission open access, *IEEE Trans. Power Syst.* 12 (1997) 1185–1193.
- [22] D. Kirschen, R. Allan, G. Strbac, Contributions of individual generators to loads and flows, *IEEE Trans. Power Syst.* 12 (1997) 52–60.
- [23] P.M. Sotkiewicz, J.M. Vignolo, Allocation of fixed costs in distribution networks with distributed generation, *IEEE Trans. Power Syst.* 21 (2006) 639–652.
- [24] R. Bhakar, V.S. Sriram, N.P. Padhy, H.O. Gupta, Cost allocation of DG embedded distribution system by game theoretic models, in: *Power & Energy Society General Meeting*, 2009. PES'09, IEEE, 2009, pp. 1–7.
- [25] T. Soares, P. Faria, Z. Vale, H. Morais, Definition of distribution network tariffs considering distribution generation and demand response, in: *Presented at the 2014 IEEE Transmission & Distribution Conference & Exposition (T&D2014)*, Chicago, USA, 2014.
- [26] A.J. Conejo, E. Castillo, R. Minguez, F. Milano, Locational marginal price sensitivities, *IEEE Trans. Power Syst.* 20 (2005) 2026–2033.
- [27] M.E. Hajiabadi, H.R. Mashhadi, LMP decomposition: a novel approach for structural market power monitoring, *Electr. Power Syst. Res.* 99 (6) (2013) 30–37.
- [28] Á. Lorca, J. Prina, Power portfolio optimization considering locational electricity prices and risk management, *Electr. Power Syst. Res.* 109 (4) (2014) 80–89.
- [29] M. Silva, H. Morais, T. Sousa, Z. Vale, Energy resources management in three distinct time horizons considering a large variation in wind power, in: *Proceedings of EWEA Annual Event 2013*, Vienna, Austria, 2013.
- [30] J. Grainger, W. Stevenson, *Power Systems Analysis*, McGraw Hill, 1994.
- [31] M.E. Baran, F.F. Wu, Network reconfiguration in distribution systems for loss reduction and load balancing, *IEEE Trans. Power Deliv.* 4 (1989) 1401–1407.
- [32] M. Silva, H. Morais, Z. Vale, An integrated approach for distributed energy resource short-term scheduling in smart grids considering realistic power system simulation, *Energy Convers. Manage.* 64 (12) (2012) 273–288.
- [33] S.B. Peterson, J. Apt, J.F. Whitacre, Lithium-ion battery cell degradation resulting from realistic vehicle and vehicle-to-grid utilization, *J. Power Sources* 195 (2010) 2385–2392.
- [34] S.B. Peterson, J.F. Whitacre, J. Apt, The economics of using plug-in hybrid electric vehicle battery packs for grid storage, *J. Power Sources* 195 (2010) 2377–2384.
- [35] ENTSO-E, ENTSO-E overview of transmission tariffs in Europe: synthesis, in: *European Network of Transmission System Operators for Electricity*, 2013.
- [36] ERSE, Regulamento de Acesso às Redes e às interligações, in: *Entidade Reguladora Dos Serviços Energéticos*, 2013 (in Portuguese).

APPENDIX **B**

## Paper B

---

**Title:**

Analysis of strategic wind power participation in energy market using MASCEM simulator

**Authors:**

Tiago Soares, Gabriel Santos, Tiago Pinto, Hugo Morais, Pierre Pinson and Zita Vale

**Published in:**

Proceedings of 18<sup>th</sup> International Conference on Intelligent System Application to Power Systems (2015).

# Analysis of Strategic Wind Power Participation in Energy Market using MASCEM simulator

Tiago Soares\*, Gabriel Santos\*\*, Tiago Pinto\*\*, Hugo Morais\*, Pierre Pinson\*, Zita Vale\*\*

\*Department of Electrical Engineering / Technical University of Denmark (DTU)

Akademivej, Building 358, DK-2800 Kgs. Lyngby, Denmark; {tiasoar, morais, ppin}@elektro.dtu.dk

\*\*GECAD – Knowledge Engineering and Decision Support Research Center

IPP – Polytechnic Institute of Porto, Porto, Portugal; {gajls, tmcfp, zav}@isep.ipp.pt

**Abstract**—In recent years the reassessment of remuneration schemes for renewable sources in several European countries has motivated the increase of wind power generation participation in electricity markets. Moreover, the continuous growth of wind power generation, as well as the evolution of wind turbines technology, suggests that wind power plants may participate in both energy and ancillary services markets with strategic behavior to improve their benefits. Thus, wind power generation with strategic behavior may have impact on market equilibrium and pricing. This paper evaluates the impact of a proportional offering strategy for wind power plants to participate in both energy and ancillary services markets. MASCEM (Multi-Agent System for Competitive Electricity Markets) is used to simulate and validate the impact of wind power plants in market equilibrium. A case study based on real and recent data for the Iberian market and its specific rules is simulated in MASCEM.

**Index Terms**—Bidding strategy, energy and ancillary services market, market simulation, multi-agent systems, wind power.

## I. INTRODUCTION

All around the world, wind power generation is growing fast and has become one of the most important energy resources in power systems [1]. This growth became possible due to high governmental incentives to increase renewable energy in power systems. Moreover, in recent years, especially in Europe, governments are trying to reduce the incentives on feed-in tariffs and enabling wind power generation to participate in the electricity market [2].

Currently in Europe, the most common schemes for wind power remuneration are: (i) feed-in tariff, (ii) feed-in premium tariff and (iii) market price plus renewable obligation certificate price [2]. Feed-in tariff is a traditional scheme that ensures a fixed price for the total wind power generation provided to the grid [3]. Feed-in premium tariff is a variant of feed-in tariff and establishes that the remuneration of a wind power plant is given by the electricity market price plus a fixed regulated premium for producing renewable energy [2], [4]. In the third scheme wind power plants sell the energy in the electricity market and can get extra remuneration by selling green certificates. Green certificates are issued to

renewable energy generators for their renewable generation. Wind power plants sell these green certificates in a specific certificates market. Traditionally, suppliers must procure “green electricity” or buy green certificates to fulfill certain levels of renewable generation obligations. These levels are established by governments and are usually imposed on suppliers. This way, wind power plants get remuneration in the electricity market and from the certificates market [2].

These schemes have enabled the high penetration of renewables sources in power systems and also in electricity markets. Consequently, the energy price tends to decrease since wind power plants participate with low price bids in the market [5] due to their low generation costs. In certain markets such as the Iberian market – MIBEL [6], Nord Pool [7] or EPEX [8], wind power plants usually submit their bids with extremely low prices, even with the value of zero.

On the other hand several studies can be found in literature analyzing the effect that strategic behavior of wind power plants may have on the market equilibrium and on wind power plant remuneration. To increase wind power owners profit, [8] and [9] propose strategic participation on both energy and regulation reserve markets. Following the market equilibrium perspective, the impacts of intermittent resources on electricity markets considering a supply function is studied in [11]. It is concluded that the behavior of wind power plants as a price taker compared to a traditional power plant can change the market price due to several reasons. On one hand, market competition can be reduced by increasing the offered price. On the other hand, the establishment of wind power bids at a price of zero decreases the market price, while at same time the uncertainty in wind power generation can increase the balancing price. In short, wind power plants decrease the market price since submitting bids with the price of zero, which can be interpreted as the reduction in the residual demand of the system, resulting in the decrease of the market price. The decrease of market price due to large penetration of wind power plants is also shown in [12] and [13]. In [14] wind power plants have strategic behavior on power generation considering the uniform price mechanism of electricity markets for mid and short-terms. A wind power accommodation mechanism based on bidding integration is

---

The authors are partly supported by the Danish Council for Strategic Research (DSF) through the project “5s – Future Electricity Markets”, (no.12-132636/DSF). This work is supported by FEDER Funds through COMPETE program and by National Funds through FCT under the projects FCOMP-01-0124-FEDER: PEst-OE/EEI/UI0760/2015; PTDC/SEN-ENR/122174/2010; and PTDC/EEA-EEL/122988/2010

shown in [15]. In addition, [5] presents several market strategies in competitive market with wind power generation. From these it is observed that wind power generation can play an important role in mitigating the power market, but should be fairly remunerated to recover its costs.

In this scope, this work presents a study focusing on the analysis of the impact of wind power plants participation in electricity markets considering strategic behavior on wind power level to be offered in the market. A proportional offering strategy for wind participation in the energy and reserve market is implemented. However, this study does not perform an evaluation of the balancing market which may affect the strategic behavior of wind power plants. In the balancing market, benefits or penalties can be allocated to wind power plants due to its uncertainty to provide the expected power. Besides that, the analysis is conducted taking into account the perspective of the market equilibrium. The proposed strategy is implemented, tested and validated in MASCEM (Multi-Agent System for Competitive Electricity Markets) [16]. This simulator is able to simulate different real electricity markets with distinct characteristics. The study is performed from a market perspective and it is based on the supply and demand bids of the Iberian market. Moreover, Iberian market rules are used during the study simulation.

The paper is structured as follows: Section II presents the detailed structure of the MASCEM simulator. Section III introduces the wind power strategy applied on the simulator. Section IV describes our empirical investigation based on the MIBEL case-study, from an economical perspective. Section V assembles the most important conclusions and discussion.

## II. ELECTRICITY MARKETS SIMULATION IN MASCEM

MASCEM [16], [17] aims to facilitate the study of complex electricity markets. It considers the most important entities and their decision support features, allowing the definition of bids and strategies, granting them a competitive advantage in the market. Players are provided with bidding strategic behavior so they are able to achieve the best possible results depending on the market context. MASCEM players include: market operator agents, independent system operator agents (ISO), market facilitator agents, buyer agents, seller agents, Virtual Power Player (VPP) [17] agents, and VPP facilitators.

MASCEM allows the simulation of the main market models: day-ahead pool (asymmetric or symmetric, with or without complex conditions), bilateral contracts, balancing market, forward markets and ancillary services. Hybrid simulations are also possible by combining the market models mentioned above. Also, the possibility of defining different specifications for the market mechanisms, such as multiple offers per period per agent, block offers, flexible offers, or complex conditions, as part of some countries' market models, is also available. Some of the most relevant market models that are fully supported by MASCEM are those of the Iberian electricity market – MIBEL, central European market – EPEX, and northern European market – Nord Pool. Some other market types can be provided by different external systems, by using an upper-ontology, which defines the main concepts that must be understood by agents that participate in power systems and electricity markets' related simulations.

Simulation scenarios in MASCEM are automatically defined, using the Realistic Scenario Generator (RealScen) [18]. RealScen uses real data that is available online, usually in market operators' websites. The gathered data concerns market proposals, including quantities and prices; accepted proposals and established market prices; proposals details; execution of physical bilateral contracts; statement outages, accumulated by unit type and technology; among others. By combining real extracted data with the data resulting from simulations, RealScen offers the possibility of generating scenarios for different types of electricity markets. Taking advantage on MASCEM's ability to simulate a broad range of different market mechanisms, this framework enables users to consider scenarios that are the representation of real markets of a specific region; or even consider different configurations, to test the operation of the same players under changed, thoroughly defined scenarios [18]. When summarized, yet still realistic scenarios are desired (in order to decrease simulations' execution time or facilitate the interpretation of results), data mining techniques are applied to define the players that act in each market. Real players are grouped according to their characteristics' similarity, resulting in a diversity of agent types that represent real market participants.

In order to allow players to automatically adapt their strategic behavior according to the operation context and with their own goals, a decision support system has been integrated with MASCEM. This platform is ALBidS (Adaptive Learning Strategic Bidding System) [19], and provides agents with the capability of analyzing contexts of negotiation, allowing players to automatically adapt their strategic behavior according to their current situation. In order to choose the most adequate strategy for each context, ALBidS uses reinforcement learning algorithms (RLA), and the Bayesian theorem of probability. The contextualization is provided by means of a context definition methodology, which analyzes similar contexts of negotiation (e.g. similar situations in the past concerning wind speed values, solar intensity, consumption profiles, energy market prices, and types of days and periods, *i.e.* business days vs. weekends, peak or off-peak hours of consumption, etc.). This contextualization allows RLAs to provide the most adequate strategic support to market players depending on each current context. ALBidS strategies include: artificial neural networks, data mining approaches, statistical approaches, machine learning algorithms, game theory, and competitor players' actions prediction, among others. Fig. 1 presents the integration of MASCEM with ALBidS.

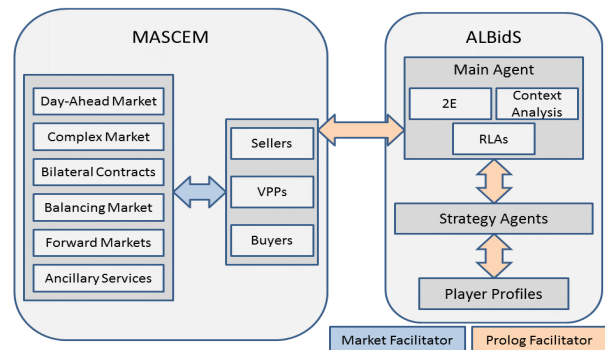

Figure 1. MASCEM's connection to ALBidS, adapted from [17].

ALBidS is implemented as a multi-agent system itself, in which each agent is responsible for an algorithm, allowing the execution of various algorithms simultaneously, increasing the performance of the platform. It was also necessary to build a suitable mechanism to manage the algorithms efficiency in order to guarantee the minimum degradation of MASCEM execution time. For this purpose, a methodology to manage the efficiency/effectiveness (2E) balance of ALBidS has been developed [19].

### III. WIND POWER PARTICIPATION IN ELECTRICITY MARKETS

#### A. Energy market

Presently and with an increasing tendency, the continuous penetration of wind power generation in power systems affects the market structure and players behavior [20]. In 2012, Portuguese wind power generation presents, on average, 20% of the total generation to supply Portuguese system demand [21]. Part of the wind power generation is traded in MIBEL, the Iberian wholesale electricity market. In Portugal the remuneration of wind power generation owners is based on two different schemes: (i) feed-in tariffs and (ii) market price plus green certificates [22]. Green certificates are issued to renewable energy generators for their renewable generation. These tradable certificates are implemented only after expiry the period of feed-in tariffs, or to renewable generators that prefer to change for the scheme of market price plus green certificates. Wind power generation owners can trade these certificates in a specific certificates market, in order to ensure higher return. Thus, most of wind power offers are usually submitted to the market at prices with the value of zero [5].

#### B. Strategical Wind Offer

In recent years, several works have already discussed and studied a significant number of strategies for trading wind power in electricity markets, with regards to the economic benefit of wind power plants. However, this issue is not the main topic studied in this work. For further interest some works on wind power strategies considering the uncertainty in production [23], [24] and in market prices [25]–[27] are recommended.

In the future, wind power plants shall be able to participate not only in the energy market but also in other markets such as the reserve market [28]. Wind generators technology have been improved in recent years and now are able to provide some ancillary services [29], [30]. This way, participation of wind power plants in such markets can represent a new business opportunity for wind generators owners, as well as can represent an alternative to traditional generators to support such services contributing to the power system security and reliability. However, for wind power plants participate in these markets, is necessary to develop new market mechanisms. In addition, it is also necessary to modify some rules imposed by system operators on wind power plants generation [31].

In addition, wind power plant owners will develop future strategies and behaviors for simultaneous participation in different markets to improve their benefits. Thus, participation of wind power plants in both markets can be done by splitting the available wind power by energy and reserve. A

proportional wind strategy (PWS) for bidding in energy and reserve market is considered [32].

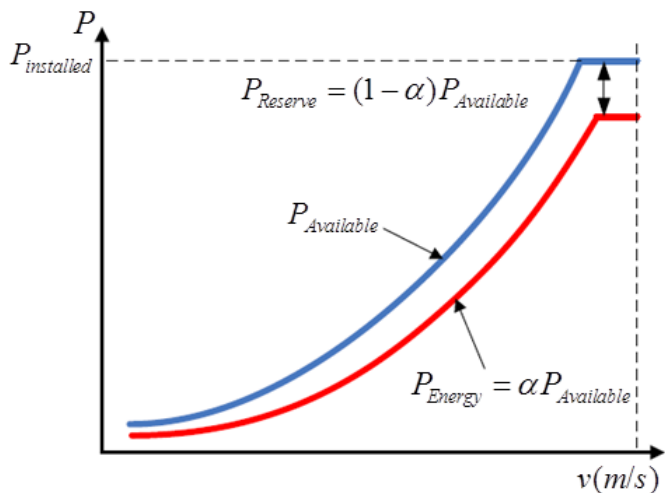

Figure 2. PWS operation (reproduced from [32] with permission).

The PWS strategy consists on a proportional splitting of the available wind generation for energy and reserve, where

$$P_{Reserve} = (1 - \alpha)P_{Available} \quad (1)$$

$$P_{Energy} = \alpha P_{Available} \quad (2)$$

such that  $\alpha$  is a parameter that establishes the amount of available power divided for both markets and can be set between 0 (total curtailment) and 1 (no reserve).

The development of new wind participation strategies will affect the energy market and the energy price, since wind participation on energy market will be different. The effect can be significant considering that wind penetration in power systems has been increasing continuously.

### IV. CASE STUDY

An empirical investigation for the evaluation of the impact of strategic bidding of wind power generation in energy market is carried out in this section. The case study is divided into two subsections – case study characterization and analysis of results.

#### A. Case-study Characterization

The presented case study is focused on the Iberian electricity market, which is composed by Portugal and Spain areas. In order to perform the analysis of the impact of wind power strategy on electricity market, offers from all players of the day-ahead market are used. The used data concerns the period between January 1<sup>st</sup>, 2012 and January 7<sup>th</sup>, 2012. The purchase and sale offers of each player are provided by the market operator OMIE (*Operador del Mercado Ibérico de Energía*) [33]. This data regards 826 distinct players, from which 714 are sellers and the remaining 112 players are buyers. From the sellers, about 397 players consider wind power generation in their portfolio mix. For each of the wind offers, PWS strategy is applied. Thus, only part of the power is submitted into the market auction. It is assumed that the remaining part of the available wind power is used by the



wind power plant player to submit in other market frame, which is independent of this work.

**B. Results**

*1) Base case scenario*

The market is cleared by MASCEM for each hour of each day of the simulation period. Fig.3 shows the purchase and sale market curves of the sixth hour of January 1<sup>st</sup>.

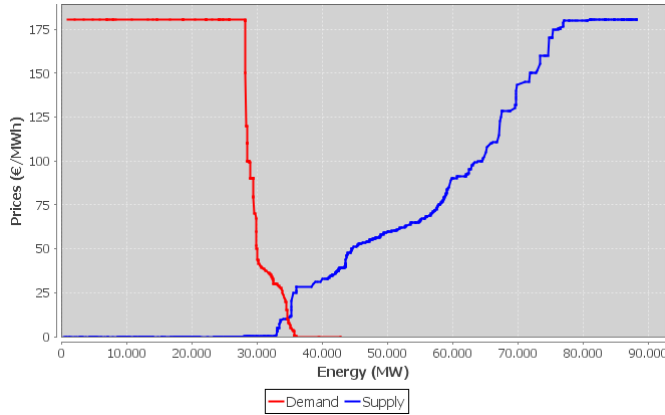

Figure 3. Purchase and sale market curves in January 1<sup>st</sup> at period 6.

The aggregation of the supply and demand curves presented in Fig. 3 considers that all the available wind power is participating on the energy market. It is noteworthy that most of wind offers in the market are settled at price of zero to ensure that wind is scheduled in the market.

The market results for the 24 hourly periods of January 1<sup>st</sup>, 2012 are illustrated by Fig. 4. One can verify the significant wind share on the market. On average, wind energy provides about 31% of the total generation scheduled in the market. This value can be higher in cases where weather conditions are favorable to wind power generation.

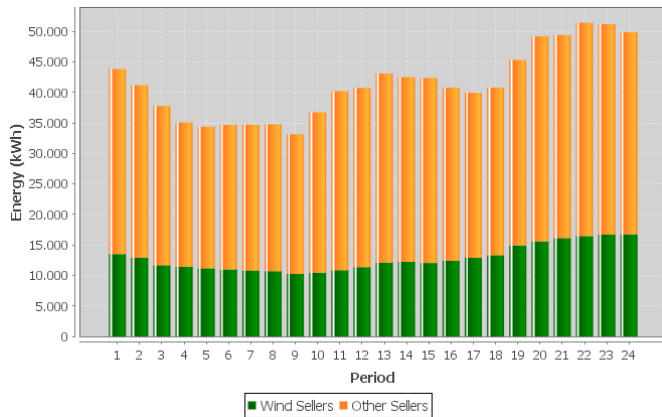

Figure 4. Day-ahead market scheduling for base case scenario.

*2) Strategy evaluation*

A sensitivity analysis for the evaluation of the impact of wind strategic offers in the energy market is presented. This analysis is performed throughout the entire period of market simulation (January 1<sup>st</sup>, 2012 to January 7<sup>th</sup>, 2012). Fig. 5 depicts an overview of the evolution of the market clearing price according to the strategic behavior of wind power

players. The horizontal axis represents the amount of available wind power (in percentage) submitted to the energy market. The vertical axis represents the evolution of the market price taking into account the amount of wind submitted in the market.

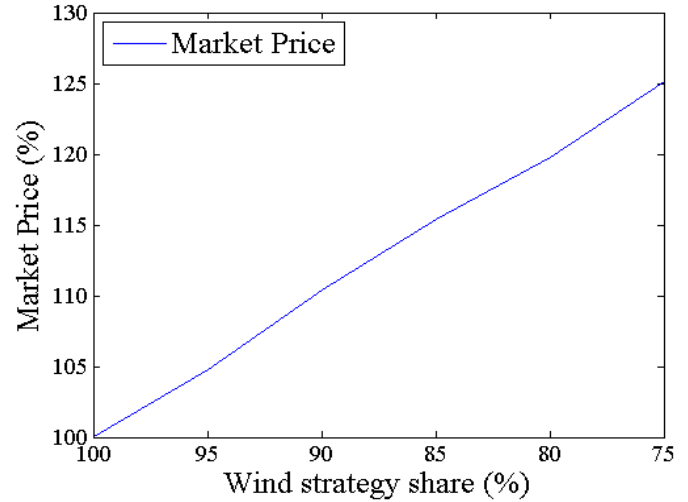

Figure 5. Impact of wind strategic behavior on market price.

From Fig. 5 it can be seen that, as expected, the energy market price increases according to the wind strategy evolution. In fact, the lowest participation of wind power generation in the energy market (wind strategy share at 75%) leads to an increase of about 25% in the market price when comparing to the base case scenario (full participation of wind power generation in the energy market).

With the increase of the market price it is understandable that the demand supplied in the market tends to decrease, since there is a larger amount of demand offers that are not scheduled in the market (Fig. 6). The vertical axis represents the evolution of the demand supplied in the market considering the amount of wind submitted in the market.

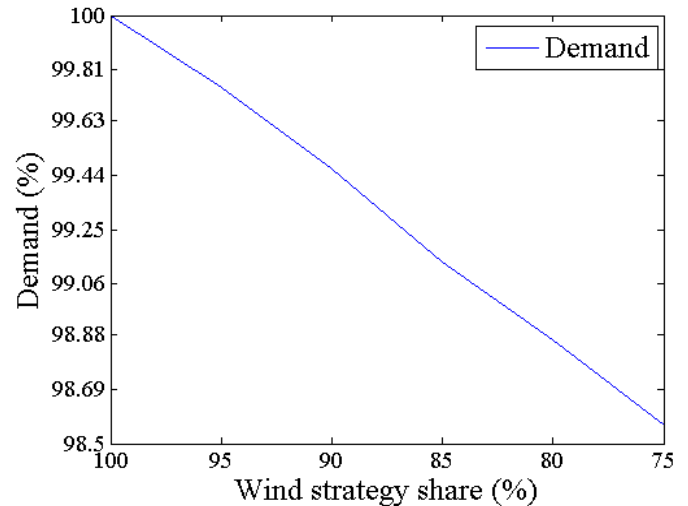

Figure 6. Impact of wind strategic behavior on supplied demand.

From Fig. 6 it is visible that, in fact, the lowest level of wind power participation in the energy market (of 75%) leads

to a decrease on demand of nearly 1.4%. The impact of the increase of the energy market price and consequent decrease of demand in the social welfare of the market is presented in Fig. 7, which shows the evolution of the social welfare throughout the application of the several values of wind power participation. The social welfare is determined based on the principle presented in [34].

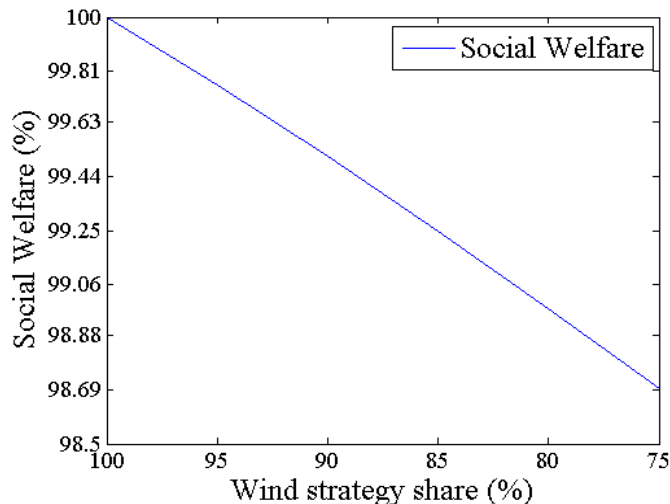

Figure 7. Impact of wind strategic behavior on social welfare.

Fig. 7 shows that the social welfare of the energy market decreases according to the decrease of power of the wind offers. The impact of wind power generation with strategic behavior on the social welfare is about 1.3% when comparing the case with the smaller strategic wind share of 75% with the base case scenario of 100% participation in the energy market.

A visual illustration of the effects of wind power strategy in the energy market mechanism for the January 1<sup>st</sup> in hour 6 is presented in Fig. 8.

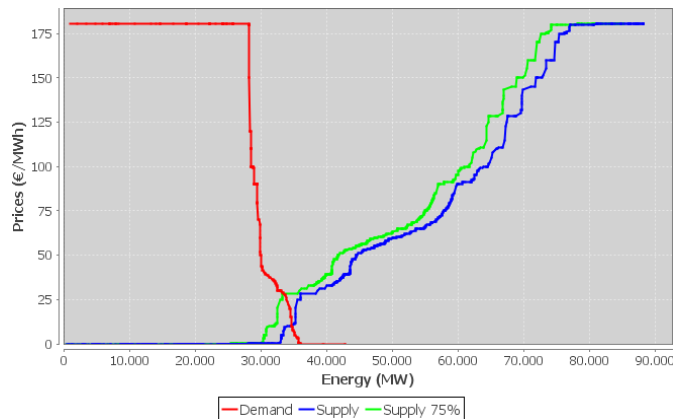

Figure 8. Impact on market uniform price mechanism.

From Fig. 8 it is visible that with the decrease of wind power participation in the market, the supply curve tends to move, resulting in higher market prices, with less supplied demand and with a consequent decrease on social welfare. With the wind strategy share at 75% of the available power forecast, the market is cleared at 28 €/MWh, while without the strategy is cleared at 10 €/MWh. It is noteworthy that the wind

power strategy causes that effect on energy market because the wind power generation is on the basis of the supply curve. Usually, the price of the wind offers is close to zero, hence, a smaller share of wind power participation in the energy market leads to a smaller amount of power placed in the market at low prices, which leads to the verified increase of the market price.

## V. CONCLUSIONS AND DISCUSSION

The increasing penetration of wind power generation in power systems and consequent integration in electricity markets is leading to the need for the development of new strategies and market mechanisms to adapt current market designs for a proper and reliable operation. This issue has been the focus of the present work, where a proportional offering strategy has been implemented and its impact on the energy market has been evaluated. The main motivation behind this work is to argue for the need to verify whether wind power participation in energy markets with strategic behavior may actually cause a greater impact on the market price and social welfare. Currently, wind power producers are assessing other opportunities in electricity markets (e.g. ancillary services market) to improve their economic benefit. Wind turbines technology has been evolving and it now allows wind power plants to provide certain ancillary services (e.g. frequency and voltage control with fast response). Thus, wind power plants are willing to participate in other markets; which leads to some difficulties in order to accommodate their integration and at the same time ensure system reliability. Wind power generation is an intermittent resource, increasing the management complexity in order to guarantee the required reliability levels, as it is required in traditional ancillary services. However, some flexible market mechanisms should be developed to allocate wind power participation in some ancillary services. This type of market integration will affect the energy market since wind power producers will be able to participate strategically in different markets. Thus, the impact on energy market price and on equilibrium should be analyzed from the market operator standpoint (in order to mitigate possible scenarios of market power participation).

In this context, one straightforward strategy that has already been proposed in the literature has been considered. The proportional wind strategy splits a percentage of the power expected from the wind power forecasts for energy and reserve. The energy share of the strategy is used in MASCEM to simulate the possible behavior of wind power plants in the day-ahead energy market. On the most extreme case presented in this work, wind power strategy reserves 25% of the available power to participate in other market frame. Thus, 75% of the available wind power is submitted to the energy market. This strategy results in an increase of the market price of about 25%, while leading to a decrease of 1.4% and 1.3% on the supplied demand and social welfare, respectively. The behavior on market price during the periods can be very different, since in some periods the effect of the strategy is low, while in other periods the effect is very high. Thus, the results achieved in this work present an overview of the strategy impact on energy market for the entire considered time horizon.

Besides the main message, this work has allowed to reach a number of practical conclusions from the evaluation of strategic behavior of wind power plants in energy market. The most important conclusions are that: (i) need for balancing market simulation in order to evaluate the strategy under penalties resulting from the wind power generation uncertainty. Penalties/benefits from the balancing market applied to wind power players can modify its remuneration and consequently its strategy behavior on future participation in the energy market; and (ii) future wind offering strategies should be further developed considering possible future scenarios where wind power plants have no more government incentives to produce energy.

The achieved results support the initial expectations that the participation of wind power generation with strategic behavior may increase the energy market price and consequently reducing the demand supplied in the market and the social welfare. Future work will focus on the integration of wind power participation in the balancing and reserve market in order to further evaluate the impact on the entire market and in wind power remuneration. Moreover, the design of flexible market mechanisms for energy and ancillary services will be implemented, evaluated and validated under realistic simulation scenarios in the MASCEM simulator.

#### ACKNOWLEDGMENT

The authors gratefully acknowledge the contribution of OMIE for providing data for the analysis.

#### REFERENCES

- [1] GWEC, "Global Wind Report - Annual Market Update 2013," 2014.
- [2] C. Hiroux and M. Saguan, "Large-scale wind power in European electricity markets: Time for revisiting support schemes and market designs?," *Energy Policy*, vol. 38, no. 7, pp. 3135–3145, Jul. 2010.
- [3] EC, "Communication From The Commission - The support of electricity from renewable energy sources," European Commission, COM(2005) 627 final, 2005.
- [4] J. Schallenberg-Rodriguez and R. Haas, "Fixed feed-in tariff versus premium: A review of the current Spanish system," *Renew. Sustain. Energy Rev.*, vol. 16, no. 1, pp. 293–305, Jan. 2012.
- [5] S. N. Singh and I. Erlich, "Strategies for Wind Power Trading in Competitive Electricity Markets," *IEEE Trans. Energy Convers.*, vol. 23, no. 1, pp. 249–256, Mar. 2008.
- [6] A. V. Santiago, "Strategic short-term model for the MIBEL electricity spot market," Comillas Pontifical University, 2012.
- [7] Energinet.dk, "Wind power to combat climate change - How to integrate wind energy into the power system," 2009.
- [8] E. Fanone, A. Gamba, and M. Prokopczuk, "The case of negative day-ahead electricity prices," *Energy Econ.*, vol. 35, no. May 2008, pp. 22–34, Jan. 2013.
- [9] J. Liang, S. Grijalva, and R. G. Harley, "Increased Wind Revenue and System Security by Trading Wind Power in Energy and Regulation Reserve Markets," *IEEE Trans. Sustain. Energy*, vol. 2, no. 3, pp. 340–347, Jul. 2011.
- [10] T. Soares, H. Morais, and P. Pinson, "Analysis of the Impact of Wind Power Participating in Both Energy and Ancillary Services Markets – The Danish Case," in *13th International Workshop on Large-Scale Integration of Wind Power and Transmission Networks*, 2014, pp. 1–6.
- [11] M. O. Buygi, H. Zareipour, S. Member, and W. D. Rosehart, "Impacts of Large-Scale Integration of Intermittent Resources on Electricity Markets: A Supply Function Equilibrium Approach," *Syst. Journal, IEEE*, vol. 6, no. 2, pp. 220–232, 2012.
- [12] F. Olsina, M. Röscher, C. Larsson, and F. Garcés, "Short-term optimal wind power generation capacity in liberalized electricity markets," *Energy Policy*, vol. 35, no. 2, pp. 1257–1273, Feb. 2007.
- [13] J. MacCormack, A. Hollis, H. Zareipour, and W. Rosehart, "The large-scale integration of wind generation: Impacts on price, reliability and dispatchable conventional suppliers," *Energy Policy*, vol. 38, no. 7, pp. 3837–3846, Jul. 2010.
- [14] M. Banaei and M. O. Buygi, "How wind power plants can affect electricity markets by gaming on their generation power?," in *2013 21st Iranian Conference on Electrical Engineering (ICEE)*, 2013, pp. 1–6.
- [15] W. Linjun, L. Yan, C. Yongning, W. Zhen, and B. Hong, "Research on market mechanism of wind power accommodation based on power bidding," in *2014 International Conference on Power System Technology*, 2014, no. Powercon, pp. 2623–2628.
- [16] I. Praça, C. Ramos, Z. Vale, and M. Cordeiro, "MASCEM: A Multiagent System That Simulates Competitive Electricity Markets," *Intell. Syst. IEEE*, vol. 18, no. 6, pp. 54–60, 2003.
- [17] T. Pinto, H. Morais, P. Oliveira, Z. Vale, I. Praça, and C. Ramos, "A new approach for multi-agent coalition formation and management in the scope of electricity markets," *Energy*, vol. 36, no. 8, pp. 5004–5015, 2011.
- [18] B. Teixeira, F. Silva, T. Pinto, I. Praça, G. Santos, and Z. Vale, "Data Mining Approach to support the Generation of Realistic Scenarios for Multi-Agent simulation of Electricity Markets," in *Intelligent Agents (IA), 2014 IEEE Symposium on*, 2014, pp. 8–15.
- [19] T. Pinto, Z. Vale, T. M. Sousa, I. Praça, and H. Morais, "Adaptive Learning in Agents Behaviour: A Framework for Electricity Markets Simulation," *Integr. Comput. Aided. Eng.*, vol. 21, no. 4, pp. 399–415, 2014.
- [20] M. Silva, H. Morais, T. Sousa, and Z. Vale, "Energy resources management in three distinct time horizons considering a large variation in wind power," *Proc. EWEA Annu. Event 2013*, 2013.
- [21] REN, "A Energia Eólica em Portugal - 2012," REN - Redes Energéticas Nacionais, [in portuguese], 2012.
- [22] PLMJ, "Renewable Energies - 2013 Legislative changes in the sector," *Energy Nat. Resour. - PLMJ*, pp. 1–4, 2014.
- [23] J. L. Angarita-Márquez, C. a. Hernandez-Aramburo, and J. Usaola-Garcia, "Analysis of a wind farm's revenue in the British and Spanish markets," *Energy Policy*, vol. 35, no. 10, pp. 5051–5059, Oct. 2007.
- [24] R. J. Barthelme, F. Murray, and S. C. Pryor, "The economic benefit of short-term forecasting for wind energy in the UK electricity market," *Energy Policy*, vol. 36, no. 5, pp. 1687–1696, May 2008.
- [25] P. Pinson, C. Chevallier, and G. N. Kariniotakis, "Trading Wind Generation From Short-Term Probabilistic Forecasts of Wind Power," *IEEE Trans. Power Syst.*, vol. 22, no. 3, pp. 1148–1156, Aug. 2007.
- [26] J. M. Morales, S. Member, A. J. Conejo, and J. Pérez-ruiz, "Short-Term Trading for a Wind Power Producer," *IEEE Trans. Power Syst.*, vol. 25, no. 1, pp. 554–564, 2010.
- [27] M. Zugno, T. Jónsson, and P. Pinson, "Trading wind energy on the basis of probabilistic forecasts both of wind generation and of," *Wind Energy*, vol. 16, no. 6, pp. 909–926, 2013.
- [28] H. Lund, F. Hvelplund, P. A. Østergaard, B. Möller, B. V. Mathiesen, P. Karnøe, A. N. Andersen, P. E. Morthorst, K. Karlsson, M. Münster, J. Munksgaard, and H. Wenzel, "System and market integration of wind power in Denmark," *Energy Strateg. Rev.*, vol. 1, pp. 143–156, 2013.
- [29] E. Ela, B. Kirby, N. Navid, and J. C. Smith, "Effective ancillary services market designs on high wind power penetration systems," in *IEEE Power and Energy Society General Meeting*, 2012.
- [30] G. Michalke and A. D. Hansen, "Grid Support Capabilities of Wind," *Handb. Wind Power Syst. Springer*, pp. 569–590, 2014.
- [31] P. Sorknæs, A. N. Andersen, J. Tang, and S. Strøm, "Market integration of wind power in electricity system balancing," *Energy Strateg. Rev.*, vol. 1, no. 3, pp. 174–180, 2013.
- [32] Y. Wang, "Evaluation de la Performance des Réglages de Fréquence des Eoliennes à l'Echelle du Système Electrique: Application à un Cas Insulaire," Ecole Centrale de Lille, L2EP, [in french], 2012.
- [33] OMIE, "Resultados de Mercado," [in spanish], 2014. [Online]. Available: <http://www.omie.es/aplicaciones/datosftp/datosftp.jsp?path=>
- [34] J. De Sousa and V. Mendes, "Integration of electricity markets: Impacts on power producer profits , consumer surplus and social welfare," in *6th Electrical Engineering College Meeting, Portuguese Engineering Association*, 2003.





APPENDIX **C**

# Paper C

---

**Title:**

Optimal offering strategies for wind power in primary reserve markets

**Authors:**

Tiago Soares, Pierre Pinson, Tue V. Jensen and Hugo Morais

**Published in:**

IEEE Transactions on Sustainable Energy (2016),  
DOI: [dx.doi.org/10.1109/TSTE.2016.2516767](https://doi.org/10.1109/TSTE.2016.2516767).

# Optimal Offering Strategies for Wind Power in Energy and Primary Reserve Markets

Tiago Soares, Pierre Pinson, *Senior Member, IEEE*, Tue V. Jensen, and Hugo Morais, *Member, IEEE*

**Abstract**—Wind power generation is to play an important role in supplying electric power demand, and will certainly impact the design of future energy and reserve markets. Operators of wind power plants will consequently develop adequate offering strategies, accounting for the market rules and the operational capabilities of the turbines, e.g., to participate in primary reserve markets. We consider two different offering strategies for joint participation of wind power in energy and primary reserve markets, based on the idea of proportional and constant splitting of potentially available power generation from the turbines. These offering strategies aim at maximizing expected revenues from both market floors using probabilistic forecasts for wind power generation, complemented with estimated regulation costs and penalties for failing to provide primary reserve. A set of numerical examples, as well as a case-study based on real-world data, allows illustrating and discussing the properties of these offering strategies. An important conclusion is that, even though technically possible, it may not always make sense for wind power to aim at providing system services in a market environment.

**Index Terms**—Ancillary services, decision-making under uncertainty, electricity markets, offering strategies, wind power.

## NOMENCLATURE

The main notation used throughout the paper is stated next for quick reference. Other symbols are defined as required.

### A. Variables

$\alpha$	Proportional strategy split for energy and reserve
$\lambda$	Prices and costs in the electricity market
$E$	Energy
$P$	Power (reserve)
$Q$	Total amount bid into day-ahead stage [MW]
$R$	Total revenue
$T$	Regulation energy market revenue
$W$	Potential penalty for primary reserve market

### B. Indices

+	Positive imbalance (downward regulation)
−	Negative imbalance (upward regulation)
*	Available energy/power at real-time stage
$bpt$	Penalty cost for reserve imbalance [€/MW]

Manuscript received July 28, 2015; revised November 07, 2015 and December 17, 2015; accepted January 01, 2016. Date of publication February 05, 2016; date of current version June 16, 2016. This work was supported by the Danish Council for Strategic Research (DSF) through the project “5 s – Future Electricity Markets.” Paper no. TSTE-00621-2015.

T. Soares, P. Pinson, and T. V. Jensen are with the Department of Electrical Engineering, Technical University of Denmark, Kgs. Lyngby 2800, Denmark (e-mail: tiasoar@elektro.dtu.dk).

H. Morais is with Département MIRE, EDF Lab Clamart, Clamart, France.

Color versions of one or more of the figures in this paper are available online at <http://ieeexplore.ieee.org>.

Digital Object Identifier 10.1109/TSTE.2016.2516767

$c$	Contracted energy/power at day-ahead stage
$cap$	Reserve price at day-ahead stage [€/MW]
$obs$	Total eventually observed power [MWh]
$pt$	Penalty for reserve imbalance [€/MW]
$r$	Fixed reserve [MW]
$sp$	Spot market

## I. INTRODUCTION

THE continuous deployment of wind power generation capacities in several countries, and especially in countries like Denmark, has an increasing impact on power system operation and electricity markets. For instance according to Energinet.dk (the Danish Transmission System Operator – TSO), December 2013 was an exceptional month where, on average, 54.8% of the electrical energy consumption was supplied by wind power [1]. According the same report, on December 1<sup>st</sup>, an extreme scenario with wind generation equal to 136% of the Danish power consumption was observed.

In the future, situations with very high wind (and most certainly also solar) generation will be more and more common, resulting in new challenges in power system operation [2]. The variability and limited predictability of wind power generation force the system operator to procure additional reserves to ensure adequate reliability of the electric power system [3]. However, according to [4] among others, wind power plants are able to provide reserves themselves, thereby reducing the additional procurement of reserves from other traditional resources. Thus, new mechanisms for reserve procurement, as well as for the participation of wind generation in providing reserves should be developed and implemented [5], [6]. Currently, wind turbine technology and wind farm control allow providing distinct ancillary services such as frequency and voltage control. Thus wind farms are able (*i*) to provide and control active power injection in a few seconds, (*ii*) to respond to reactive power demands in less than 1 second, (*iii*) to support and maintain voltage levels, and (*iv*) to provide kinetic energy (virtual inertia) [4], [7]–[9].

Traditionally, primary reserve markets are designed to assist in dampening deviations from nominal frequency. Generators supply the service based on their inertia characteristics. Depending on the country rules, this service can either be supplied and priced through market mechanisms [4] or made mandatory without payment. With high penetration of variable generation, the service design tends to change, since reserve requirements may dynamically vary on an hourly or even minute basis [10], while the system may have lower inertia. Wind power plants and other emerging generating technologies

may then be asked to contribute to this new service design [11], [12].

For optimal integration of wind power in energy and primary reserve markets, new business models and remuneration mechanisms should be thought of. The literature on optimal offering strategies for wind power producers in the day-ahead market while accounting for potential balancing costs has been flourishing over the last few years. This includes a number of studies (assuming that wind power producer act as a price-taker) on expected utility maximization strategies [13], [14], additional consideration on risk-aversion and temporal dependencies [15], extension to LMP markets [16] and multi-period setting to adjust contracted offerings [17], appraisal of uncertainties on both wind and market quantities [18], bidding under one-price and two-price system [19], generalized opportunity cost bidding [20], as well as minimizing imbalance costs accounting for wind power predictions and imbalance prices [21], among others. Although it is not the goal of the present paper to work on optimal strategies assuming that the wind power producer acts as a price-maker, readers are encouraged to consult these recent works [22]–[27] for detailed information.

In contrast, little attention has been paid to the joint offering under uncertainty of wind power generation in both energy and reserve markets [12], [28]. Liang *et al.* [12] proposes an analytical approach (based on the so called multi-news vendor problem with budget constraint) for wind power participating in energy and reserve, assuming that offers for energy and reserve can be freely determined (i.e., independently of any control paradigm), since only subject to this budget constraint. Such joint offering strategies are expected to bring additional revenue streams to wind power plant operators. However, wind power plants face the challenge to guarantee that power scheduled as primary reserve is available at any time without failure. The reserve market is designed to ensure the operation of electric power systems with appropriate levels of stability, safety, quality, reliability and competitiveness. In this way, intermittent energy resources, such as wind power, have difficulties to ensure and fulfil power scheduled as primary reserve. Thus, a future reserve market must be designed to account for the possibility of wind failing to provide reserve, e.g. through penalties, if wind (or demand-response) is to participate in these markets.

This paper proposes an analytical approach for wind power participating in both energy and primary reserve markets taking into account the market penalties. The aim is to maximize the expected revenue from optimal offering on both energy and primary reserve markets. Our approach takes a different starting point is compared to previous work in the literature, e.g. [12], as instead of considering a budget constraint for the joint offering of energy and reserves, we first start from the various control paradigms described in the literature for wind to offer system services in practice. A major contribution of this work is the implementation, evaluation and comparison of two different offering strategies, namely the proportional and the constant wind strategies proposed in [29], [30], for the splitting of potentially available wind power considering the same wind distribution probability for the two services. In practice, they are easy to implement since uses simple controllers due to the locking of energy and reserve quantities [30], while strategies that utilize all operational degrees of

freedom would require advanced controllers that are unlikely to admit analytical treatment, and may be highly susceptible of misestimate due to forecast errors. An advantage of our approach is then to show how offering behavior and market revenues can be highly affected by the control paradigm originally adopted. Both strategies are introduced with the motivation of allowing the split of the available wind power for energy and reserve. Furthermore, an economical evaluation of both strategies illustrating their advantages and inconveniences is undertaken. Optimal offers are determined under uncertainty based on probabilistic forecasts of potential power generation for the market time unit considered. Additional input variables include expected market prices (for energy and reserve) as well as expected penalties on balancing and reserve mechanisms. The methodology is applied and demonstrated on numerical examples. Wind power plants increase their profit by using these strategies for optimally offering in energy and reserve markets, thereby reducing the deviation penalties from the balancing market. Additionally, these strategies seek to motivate wind power penetration on power system, thereby, increasing the competition in both markets, as well as ensuring a cheap resource in the system operator standpoint. Besides that, future wind power plants will be able to provide fast reserve services that will be crucial in the operation of future power systems with high penetration of renewable resources [12]. Thus, system operators have interest in wind power participating in both energy and reserve markets.

The paper is structured as follows. Section II describes electricity markets characteristics with a perspective on future energy and reserve market trends. Section III presents the detailed formulation of joint offering strategies (for proportional and constant strategies) in energy and primary reserve markets. Section IV describes our empirical investigation based on a set of numerical examples. Section V assembles the most important conclusions.

## II. WIND POWER IN ELECTRICITY MARKETS

### A. Current Day-Ahead and Balancing Market

The increasing penetration of wind power generation in electric power systems has been changing wholesale market characteristics. In Denmark, wind power producers trade in the wholesale market and are remunerated through a combination of market price and premium [28]. This remuneration mechanism allows wind power owners to submit bids into the day-ahead market with zero or negative prices [29].

The balancing market is used to compensate for energy deviations in real time from the day-ahead and intra-day schedules. In a European context these are run by the local TSO [30]. For the example of Denmark, this market is cleared just before the operating hour and is divided into a regulating power market (where the system operator purchases the required regulating power to balance the system) and a balancing power market (where correction of the system and market participant imbalances is performed) [31]. For the case of wind power, the balancing market is the final mechanism permitting to mitigate forecast errors, and it can be highly penalizing.

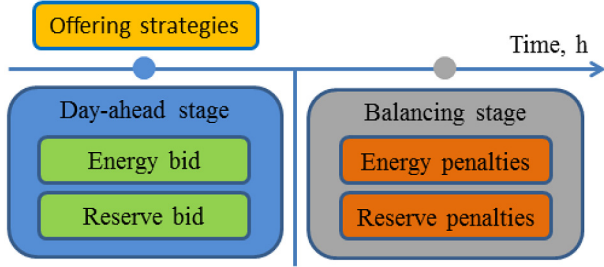

Fig. 1. Schematic representation of the market structure for the wind offering strategies.

### B. Joint Offering in Energy and Primary Reserve Markets

Currently and even more in the future, wind power plants will be able to provide some type of ancillary services, such as frequency and voltage control [4]. Wind power plants are willing to participate in energy and primary reserve market only in the case where wind power producers may receive increased benefits from joint market participation, instead of participating in the energy market only. With that objective in mind, we will examine an analytical model for obtaining the optimal quantile bid of wind power participating in multiple markets with different expected prices and penalties for deviation from schedule.

The energy and reserve markets have different characteristics. On the one hand, wind energy bids submitted in the day-ahead market should account for potential imbalance situations and their asymmetric penalties. On the other hand, bids submitted in the primary reserve market are to accommodate the possibility to fail in providing the service, certainly associated with a much higher penalty. Fig. 1 presents the structure of the market for the offering strategies determination.

The bids submitted at the day-ahead market consider the expected costs in the balancing stage. In the formulation outlined here, the effect which the day-ahead bid has on the penalties of the balancing market, known as the time coupling effect, is not captured. We assume that any differences arising from this effect cancel out over time.

The formulation considers the important assumption of the split between energy and primary reserve remain the same in both day-ahead ( $\alpha^c$ ) and balancing stages ( $\alpha^*$ ). This allows us to develop an analytical formulation to solve the problem. Future work may involve stochastic programming [32] allowing different energy and reserve share between day-ahead and balancing stages, thereby, reducing the time coupling effect.

## III. METHODOLOGY

### A. General Formulation of Market Revenues

The objective function to be optimized directly relates to the maximization of the combined revenue from day-ahead and reserve markets considering the penalties from the balancing market. Time indices are not used, since all variables and parameters are for the same market time unit. This combined revenue  $R$  in real-time for a given wind power producer

is expressed as

$$R = \lambda^{sp} E^* + \lambda^{cap} P^* - T^* - W^* \quad (1)$$

where  $\lambda^{sp}$  is the spot price,  $E^*$  is the amount of delivered energy,  $\lambda^{cap}$  is the capacity price for primary reserve allocation,  $P^*$  is the deployed level of primary reserve in real-time,  $T^*$  is the regulation costs from the regulation market and  $W^*$  is the penalty cost for wind power plant failing to provide the scheduled primary reserve.

In addition, we assume that the wind power producer acts as a price-taker. This means that the production of the wind power producer is independent of market prices and penalties. Because of this independence, and the fact that all prices enter linearly in the expressions below, all calculations depend only on the expected mean prices, rather than their full distribution. This reduction follows from certainty equivalent theory [36], and removes the need for a full stochastic description of prices using, e.g., scenarios [18]. In the following, we will refer to the sum of  $\lambda^{sp} E^*$  and  $\lambda^{cap} P^*$  as the expected inflow. In parallel, the sum of  $T^*$  and  $W^*$  is referred to as expected costs. Subtracting the expected costs from the expected inflow yields the expected revenue of the wind power producer. In (1), the regulation costs are defined as

$$T^* = \begin{cases} \lambda^{*,+} (E^* - E^c), & E^* - E^c \geq 0 \\ -\lambda^{*,-} (E^* - E^c), & E^* - E^c < 0 \end{cases} \quad (2)$$

where  $(E^* - E^c)$  is the energy imbalance between the energy delivered  $E^*$  and the energy contracted (offered)  $E^c$ . The variables  $\lambda^{*,+}$  and  $\lambda^{*,-}$  are the regulation unit costs for positive and negative deviations, i.e.,

$$\begin{aligned} \lambda^{*,+} &= \lambda^{sp} - \lambda^{c,+} \\ \lambda^{*,-} &= \lambda^{c,-} - \lambda^{sp} \end{aligned} \quad (3)$$

where  $\lambda^{c,+}$  is the unit down-regulation price for being long, while  $\lambda^{c,-}$  is the up-regulation price for being short.

We place ourselves here in under two-price settlement rule, as in the NordPool [13]. In cases where the system imbalance is negative (energy surplus – need for downward regulation), it holds that

$$\begin{aligned} \lambda^{c,+} &\leq \lambda^{sp} \\ \lambda^{c,-} &= \lambda^{sp} \end{aligned} \quad (4)$$

In contrast, when system imbalance is positive (energy deficit – need of upward regulation), one has

$$\begin{aligned} \lambda^{c,+} &= \lambda^{sp} \\ \lambda^{c,-} &\geq \lambda^{sp} \end{aligned} \quad (5)$$

While finally during hours of perfect balance both  $\lambda^{c,+}$  and  $\lambda^{c,-}$  are equal to the spot price  $\lambda^{sp}$ . In parallel, the penalty costs for reserve imbalance can be written as

$$W^* = \begin{cases} \lambda^{bpt,+} (P^* - P^c), & P^* - P^c \geq 0 \\ -\lambda^{bpt,-} (P^* - P^c), & P^* - P^c < 0 \end{cases} \quad (6)$$

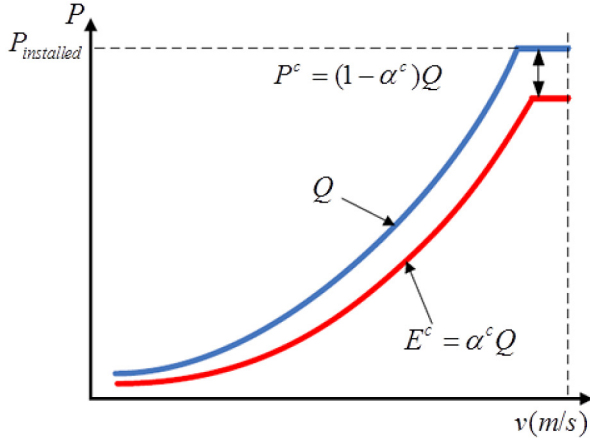

Fig. 2. Proportional wind offering strategy (reproduced with authorization from [29], [30]).

where  $(P^* - P^c)$  is the primary reserve power imbalance between the realized level of reserve  $P^*$  and the reserve contracted (offered)  $P^c$ .  $\lambda^{bpt,+}$  is a unit penalty when wind producer generate more power than the contracted (surplus), and  $\lambda^{bpt,-}$  is the unit penalty cost when wind power producer generate less than contracted. These are given by

$$\begin{aligned} \lambda^{bpt,+} &= \lambda^{cap} - \lambda^{pt,+} \\ \lambda^{bpt,-} &= \lambda^{pt,-} - \lambda^{cap} \end{aligned} \quad (7)$$

hence  $\lambda^{pt,+} = 0$  since (extra) positive reserve is not detrimental to the system's reliability.  $\lambda^{pt,-}$  is the penalty for negative reserve imbalance, weighted by the probability that reserve is needed.

In principle, a wind power producer can bid any  $E^c, P^c \geq 0$  into the day-ahead market, and choose to deliver any amount  $E^*, P^* \geq 0$  in real time, bounded by  $E^* + P^* \leq E^{obs}$ , the observed energy. To make the problem analytically tractable, we proceed by constraining the choice of  $E^*$  and  $P^*$  based on  $E^c$  and  $P^c$ . This restriction is performed through the use of two known strategies, which have been previously shown to be operationally feasible [26], [27]. The following subsections define these strategies, while the analytical optimal bids are finally given.

### B. Proportional Wind Offering Strategy

The proportional wind offering strategy (illustrated in Fig. 2) consists in a proportional curtailment of available power generation to yield an energy offer  $E^c$  and a primary reserve offer  $P^c$  [29], where

$$\begin{aligned} E^c &= \alpha^c Q \\ P^c &= (1 - \alpha^c) Q \end{aligned} \quad (8)$$

In the above,  $Q$  denotes the total power bid in MW for that market time unit and  $\alpha^c$  is the strategy parameter controlling the proportional split between energy and primary reserve bids. This last parameter naturally varies between 0 (for full reserve allocation) and 1 (for full energy allocation).

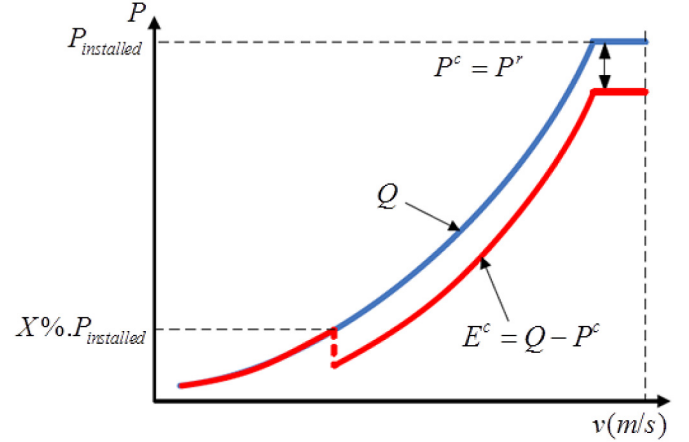

Fig. 3. Constant wind offering strategy (reproduced with authorization from [29], [30]).

On the other hand, the eventually observed wind power production  $E^{obs}$  is similarly composed of an energy portion  $E^*$  and  $P^*$  the amount of primary reserve actually available,

$$\begin{aligned} E^* &= \alpha^* E^{obs} \\ P^* &= (1 - \alpha^*) E^{obs} \end{aligned} \quad (9)$$

where  $\alpha^*$  is the strategy parameter used when reaching real-time operation. It is assumed that strategy parameter in day-ahead and real-time are the same  $\alpha^* = \alpha^c$ .

### C. Constant Wind Offering Strategy

The constant wind offering strategy (Fig. 3) is based on a constant curtailment of energy when the expected energy produced is over a certain expected level of wind power [26], where

$$\begin{aligned} E^c &= Q - P^c \\ P^c &= P^R \end{aligned} \quad (10)$$

$P^R$  is the amount of fixed reserve to be submitted in the primary reserve market, and  $X\%$  is the percentage of installed wind power.

Similar to the proportional strategy, the observed wind production  $E^{obs}$  is related to  $E^*$ . The reserve amount is assumed to be constant and fixed in day-ahead decision. That is, priority delivery of the reserve is assumed. The delivered amount of energy and primary reserve may be written as

$$\begin{aligned} E^* &= E^{obs} - P^* \\ P^* &= P^r \end{aligned} \quad (11)$$

## IV. ANALYTICAL DERIVATION OF OPTIMAL BIDS

### A. Proportional Strategy Optimization Problem

Assuming that the wind power plant acts as a price-taker, the maximization of its expected revenues is equivalent to the minimization of the expectation of regulation and penalty costs.



Optimal offers are then the solution of

$$(\tilde{Q}, \tilde{\alpha}^c) = \arg \min_{Q, \alpha^c} \mathbb{E} \{ T^* + W^* - \lambda^{sp} E^* - \lambda^{cap} P^* \} \quad (12)$$

The loss function in the above comprises an extended version of that used in [13], where here, the available wind power is split into two different market products. The share of the available expected power  $\alpha^c$  and observed power  $\alpha^*$  for energy and reserve participation is the same ( $\alpha^* = \alpha^c$ ). Consequently, the total expected costs  $O$  are given by

$$\begin{aligned} O(Q, \alpha^c) = & \int_0^Q \left[ \begin{aligned} & \lambda^{*, -} \alpha^c (Q - x) + \\ & \lambda^{bpt, -} (1 - \alpha^c) (Q - x) - \end{aligned} \right] f(x) dx \\ & + \int_Q^1 \left[ \begin{aligned} & \lambda^{*, +} \alpha^c (x - Q) - \\ & \lambda^{sp} \alpha^c x - \lambda^{cap} (1 - \alpha^c) \end{aligned} \right] f(x) dx \end{aligned} \quad (13)$$

where  $f(x)$  is the forecast probability density function of the wind power plant production. To analytically solve the problem the Leibniz rule is used. The Leibniz rule, for an arbitrary function  $f$ , parameters  $\theta$ , and integration bounds  $a$  and  $b$ , tells that

$$\begin{aligned} \frac{\partial}{\partial \theta} \left( \int_{a(\theta)}^{b(\theta)} f(x, \theta) \right) = & \int_0^1 \partial_\theta f(x, \theta) dx + f(b(\theta), \theta) \cdot b'(\theta) \\ & - f(a(\theta), \theta) \cdot a'(\theta) \end{aligned} \quad (14)$$

Thus, the derivative of (13) with respect to  $Q$  is given by

$$\begin{aligned} \frac{\partial O}{\partial Q}(Q, \alpha^c) = & \int_0^Q [\lambda^{*, -} \alpha^c + \lambda^{bpt, -} (1 - \alpha^c)] f(x) dx \\ & - [\lambda^{sp} \alpha^c Q + \lambda^{cap} (1 - \alpha^c) Q] f(Q) \\ & + \int_Q^1 [-\lambda^{*, +} \alpha^c - \lambda^{cap} (1 - \alpha^c)] f(x) dx \\ & + [\lambda^{sp} \alpha^c Q + \lambda^{cap} (1 - \alpha^c) Q] f(Q) \end{aligned} \quad (15)$$

The optimal bid is obtained by equating the derivative in (15) to 0, then yielding an optimal quantile of the predictive cumulative distribution function  $F$  for wind power generation at that lead time

$$Q = F^{-1} \left[ \frac{\lambda^{*, +} \alpha^c + \lambda^{cap} (1 - \alpha^c)}{(\lambda^{*, -} + \lambda^{*, +}) \alpha^c + (\lambda^{bpt, -} + \lambda^{cap}) (1 - \alpha^c)} \right] \quad (16)$$

Similarly, the derivative of (13) with respect to  $\alpha^c$  writes

$$\begin{aligned} \frac{\partial O}{\partial \alpha^c}(Q, \alpha^c) = & \int_0^Q \left[ \begin{aligned} & \lambda^{*, -} (Q - x) - \\ & \lambda^{bpt, -} (Q - x) - \lambda^{sp} x + \lambda^{cap} x \end{aligned} \right] f(x) dx \\ & + \int_Q^1 [\lambda^{*, +} (x - Q) - \lambda^{bpt, +} (x - Q) - \lambda^{sp} x + \lambda^{cap} x] f(x) dx \end{aligned} \quad (17)$$

Equation (17) is a nonlinear equation in  $Q$ . Its solutions determine the possible  $Q$  values that may be used. Note that Eq. (13) is affine in  $\alpha^c$ , with the sign of the coefficient of  $\alpha^c$

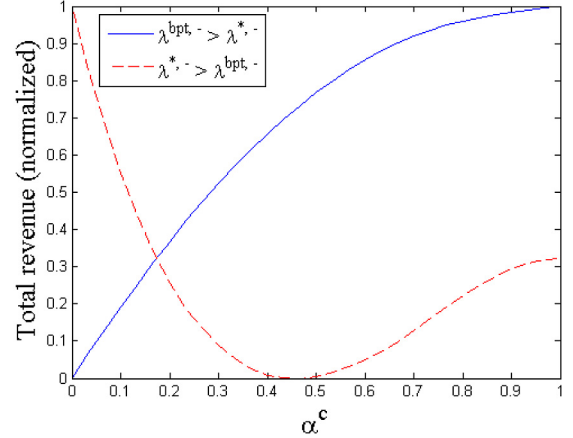

Fig. 4. Illustrative behaviour of Eq. (13) under different relations for energy and reserve penalties. Note, that revenues are maximized for  $\alpha^c = 0$  or  $1$ , i.e. the wind power producer participates fully in one market or the other.

depending on  $\tilde{Q}$ . This means that Eq. (13) will be maximized for one of  $\alpha^c = 0$  or  $\alpha^c = 1$ . Bids from this proportional strategy will take place in either the energy or the reserve market, but never in both (see Fig. 4). In this way, the energy bid is equal to the total expected energy when the reserve penalty is higher than the energy penalty ( $\lambda^{bpt, -} > \lambda^{*, -}$ ), so total availability is submitted to the energy market. On the contrary, when the energy penalty is higher than the reserve penalty ( $\lambda^{*, -} > \lambda^{bpt, -}$ ), the total expected power is submitted to the primary reserve market.

## B. Constant Strategy Optimization Problem

The constant strategy assumes that a certain amount of the available power is fixed to participate in the primary reserve market, while the remaining available power is submitted in the energy market [26]. The strategy splits into three distinct domains according to the relationship between the prices on day-ahead markets, and the penalties for energy and reserve deviations.

1) *Normal Operation*: Under current electricity markets regulatory framework it is more advantageous for wind power plants to provide energy than to provide reserve, since the energy price is usually higher than the reserve price [37]. If renewable energy producers are able to provide in reserve markets, market operators should ensure appropriate price signals to provide incentive for wind power plants to offer their flexibility [4]. I.e. the reserve price must be higher than the energy price ( $\lambda^{cap} \geq \lambda^{sp}$ ). The normal operational hierarchy of electric power systems implies that not meeting a call for reserve is worse than not producing the energy promised, such that the reserve penalty should be higher than the energy regulation penalty ( $\lambda^{bpt, -} \geq \lambda^{*, -}$ ). The derivation below assumes that these relations hold. The derivation is also valid for the inverse case  $\lambda^{*, -} \geq \lambda^{bpt, -}$  and  $\lambda^{sp} \geq \lambda^{cap}$ , but for the above reasons, we expect that the inverse case is unlikely to occur in practice.

Again assuming the wind power plant is a price-taker, the expected available power  $Q$ , and the primary reserve offer

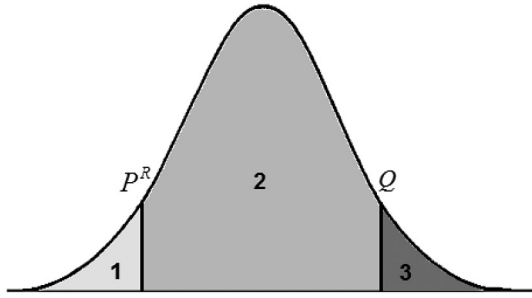

Fig. 5. Regions of operation of constant strategy.

$P^R$ , are determined from a minimization of the expectation of regulation and penalties costs. This writes

$$(\tilde{Q}, \tilde{P}^R) = \arg \min_{Q, P^R}^{\mathbb{E}} \{T^* + W^* - \lambda^{sp} E^* - \lambda^{cap} P^*\} \quad (18)$$

This problem contains three different regions of operation (Fig. 5): (i) observed wind energy lower than fixed reserve offer  $P^R \geq E^{obs}$ , (ii) observed wind power between fixed reserve offer and expected wind power  $Q \geq E^{obs} \geq P^R$ , and (iii) observed power higher than expected wind power  $E^{obs} \geq E^{exp}$ .

The mathematical formulation which minimizes the total expected costs ( $O$ ) is as follows

$$\begin{aligned} O(Q, P^R) &= \int_0^{P^R} \left[ \lambda^{*, -} (Q - P^r) + \lambda^{bpt, -} (P^r - x) - \lambda^{cap} P^r \right] f(x) dx \\ &+ \int_{P^R}^Q [\lambda^{*, -} (Q - x) - \lambda^{sp} (x - P^r) - \lambda^{cap} P^r] f(x) dx \\ &+ \int_Q^1 [\lambda^{*, +} (x - Q) - \lambda^{sp} (x - P^r) - \lambda^{cap} P^r] f(x) dx \end{aligned} \quad (19)$$

The integrals correspond respectively to the operation regions 1, 2, and 3 in Fig. 5. We proceed to minimize this function by differentiation. The derivative of (19) with respect to  $Q$  is given by

$$\begin{aligned} \frac{\partial O}{\partial Q}(Q, P^R) &= \int_0^{P^R} \lambda^{*, -} f(x) dx + \int_{P^R}^Q \lambda^{*, -} f(x) dx \\ &- [\lambda^{sp} (Q - P^r) + \lambda^{cap} P^r] f(Q) + \int_Q^1 -\lambda^{*, +} f(x) dx \\ &+ [\lambda^{sp} (Q - P^r) + \lambda^{cap} P^r] f(Q) \end{aligned} \quad (20)$$

which leads to

$$Q = F^{-1} \left[ \frac{\lambda^{*, +}}{\lambda^{*, -} + \lambda^{*, +}} \right] \quad (21)$$

The derivative of (18) with respect to  $P^r$  is

$$\begin{aligned} \frac{\partial O}{\partial P^r}(Q, P^R) &= \int_0^{P^R} [\lambda^{bpt, -} - \lambda^{*, -}] f(x) dx \\ &+ [\lambda^{*, -} (Q - P^r) - \lambda^{cap} P^r] f(P^r) + \int_{P^R}^Q [\lambda^{sp} - \lambda^{cap}] f(x) dx \\ &- [\lambda^{*, -} (Q - P^r) - \lambda^{cap} P^r] f(P^r) + \int_Q^1 [\lambda^{sp} - \lambda^{cap}] f(x) dx \end{aligned} \quad (22)$$

This finally yields the optimal bid for reserve participation

$$P^r = F^{-1} \left[ \frac{\lambda^{cap} - \lambda^{sp}}{\lambda^{bpt, -} - \lambda^{*, -} + \lambda^{cap} - \lambda^{sp}} \right] \quad (23)$$

2) *Special Operation—Reserve Only Market*: There are a few cases where the strategy should be decoupled to participate in a single reserve market: when the energy bid is negative—only reserve market participation; and when  $\lambda^{bpt, -} < \lambda^{*, -}$  and  $\lambda^{cap} \geq \lambda^{sp}$ , the full availability of the wind producer should be submitted to the reserve market.

In that case, the objective function is a special case of that in Eq. (19), i.e.,

$$\begin{aligned} O(P^r) &= \int_0^{P^r} [\lambda^{bpt, -} (P^r - x) - \lambda^{cap} x] f(x) dx \\ &+ \int_{P^r}^1 \left[ \lambda^{*, +} (x - P^r) - \lambda^{sp} (x - P^r) - \lambda^{cap} P^r \right] f(x) dx \end{aligned} \quad (24)$$

The derivative with respect to  $P^R$  is obtained as

$$\begin{aligned} \frac{\partial O}{\partial P^r}(P^r) &= \int_0^{P^r} \lambda^{bpt, -} f(x) dx - [\lambda^{cap} P^r] f(P^r) \\ &+ \int_{P^r}^1 [\lambda^{sp} - \lambda^{*, +} - \lambda^{cap}] f(x) dx + [\lambda^{cap} P^r] f(P^r) \end{aligned} \quad (25)$$

resulting in the optimal quantile bid for reserve participation,

$$P^r = F^{-1} \left( \frac{\lambda^{*, +} + \lambda^{cap} - \lambda^{sp}}{\lambda^{bpt, -} + \lambda^{*, +} + \lambda^{cap} - \lambda^{sp}} \right) \quad (26)$$

3) *Special Operation—Energy Only Market*: In cases where  $\lambda^{bpt, -} \geq \lambda^{*, -}$  and  $\lambda^{cap} < \lambda^{sp}$ , it is intuitive that the wind power producer will opt to participate in the energy market only. The objective function for this case is a particular case of Eq. (19), given by

$$\begin{aligned} O(Q) &= \int_0^Q [\lambda^{*, -} (Q - x) - \lambda^{sp} x] f(x) dx \\ &+ \int_Q^1 [\lambda^{*, +} (x - Q) - \lambda^{sp} x] f(x) dx \end{aligned} \quad (27)$$

The derivative of (27) with respect to  $E^{exp}$  becomes

$$\frac{\partial O}{\partial Q}(Q) = \int_0^Q \lambda^{*, -} f(x) dx + \int_Q^1 \lambda^{*, +} f(x) dx \quad (28)$$

which results in the well-known quantile for energy-only participation

$$Q = F^{-1} \left( \frac{\lambda^{*, +}}{\lambda^{*, -} + \lambda^{*, +}} \right) \quad (29)$$

### C. Strategies Summary

A general overview of the analytical formulas to obtain optimal offers in both markets and for both strategies is given in Table I.



TABLE I  
SUMMARY OF OPTIMAL BIDS

Strategy	Normal operation		Special operation	
	$Q$	$P^r$	$Q$	$P^r$
Constant	(21)	(23)	(29)	(26)
Proportional	(16)	(17)	-	-

TABLE II  
PRICES AND PENALTIES IN ENERGY AND RESERVE MARKET

Energy	Price (€/MWh)	Reserve	Price (€/MW)
$\lambda^{sp}$	22	$\lambda^{cap}$	25
$\lambda^{c,+}$	17	$\lambda^{bpt,+}$	0
$\lambda^{c,-}$	32	$\lambda^{pt,-}$	60

TABLE III  
SIMULATION RESULTS FOR STRATEGIES BASED ON PROPORTIONAL, CONSTANT, AND ENERGY-ONLY MARKET STRATEGY

Strategy	Proportional	Constant	Energy-only
Energy bid (MWh)	7.018	3.516	7.018
Reserve bid (MW)	0	3.502	-
Total expected power (MW)	7.018	7.018	7.018
Expected inflow (€)	225.48	235.61	225.48
Expected costs (€)	29.92	33.03	29.92
Expected revenue (€)	195.56	202.58	195.56

TABLE IV  
SIMULATION RESULTS FOR  $\lambda^{cap}$  LARGER THAN  $\lambda^{sp}$  FOR PROPORTIONAL, CONSTANT, AND ENERGY-ONLY MARKET STRATEGIES

Strategy	Proportional	Constant	Energy-only
Energy bid (MWh)	0	0	7.018
Reserve bid (MW)	12.063	9.936	-
Total expected power (MW)	12.063	9.936	7.018
Expected inflow (€)	381.57	365.24	225.48
Expected costs (€)	75.72	55.86	29.92
Expected revenue (€)	305.85	309.40	195.56

## V. EVALUATION OF OFFERING STRATEGY

### A. Test Cases

1) *Base Case:* The base case is based on the following parameters and assumptions. The wind power plant has a 30 MW installed capacity. An example probabilistic wind power forecasts takes the form of a beta distribution with shape parameters  $\alpha = 2$  and  $\beta = 4$ . The expected revenue is evaluated using 1000 samples for wind production drawn from this distribution. Besides, Table II gathers the prices for energy and reserve in our numerical example, as well as the unit penalty for up and down deviations from contract.

The evaluation of the proportional strategy is performed by an iterative process.  $\alpha^c$  is assumed to vary between 0 and 1 with steps of 0.03.  $Q$  is determined based on Eq. (16) for each  $\alpha^c$ . The total revenue for each given  $\alpha^c$  is determined.

The constant strategy is first analyzed based on the most realistic assumption on the relation between penalties and market prices, i.e., such that  $\lambda^{bpt,-} \geq \lambda^{*,-}$  and  $\lambda^{cap} \geq \lambda^{sp}$ . In this case, Eqs. (21) and (23) are used to determine the energy and the reserve bid, respectively.

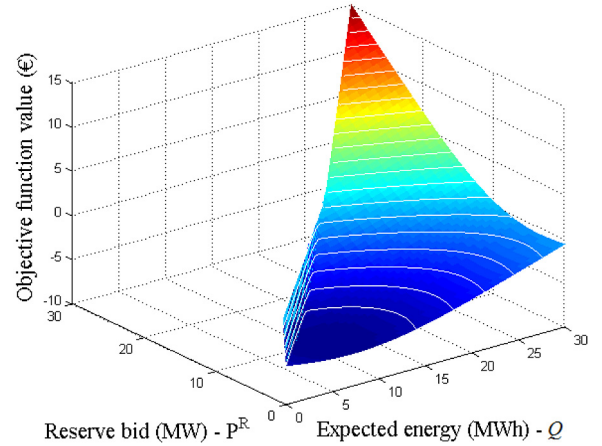

Fig. 6. Objective function behavior for constant strategy, based on base case data.

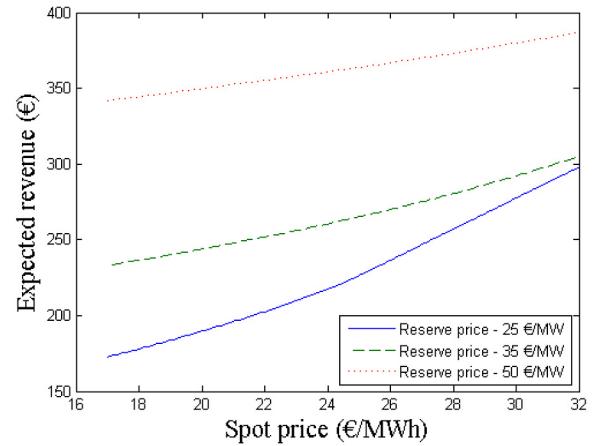

Fig. 7. Expected revenue for constant strategy under variation of day-ahead energy and primary reserve market prices.

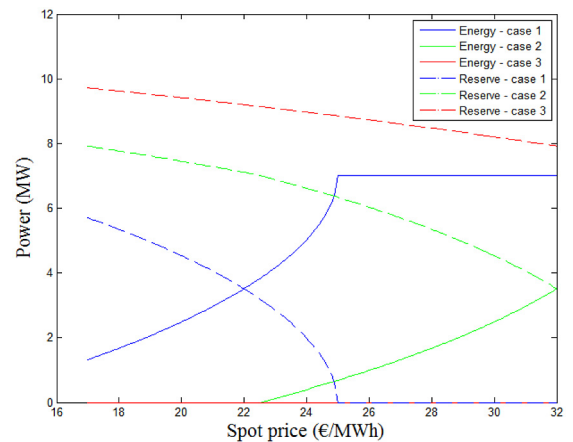

Fig. 8. Expected share of energy and reserve for constant strategy under variation of day-ahead energy and primary reserve market prices. Dashed lines represents the primary reserve share for each case of primary reserve price (case 1 – reserve price of 25 €/MW; case 2 – reserve price of 35 €/MW; and case 3 – reserve price of 50 €/MW).

Table III shows a comparison between three different strategies for participation in electricity markets (proportional, constant and energy-only). The expected revenue is the difference

TABLE V  
CUMULATIVE SIMULATION RESULTS OF TWO YEARS DATA FOR PROPORTIONAL, CONSTANT, AND ENERGY-ONLY MARKET STRATEGIES

Strategy Data	Proportional		Constant		Energy-only	
	Forecast	Deployed	Forecast	Deployed	Forecast	Deployed
Energy bid (MWh)	0	0	11930.297	18334.760	20490.612	23519.591
Reserve bid (MW)	26195.071	23519.591	8686.597	5184.831	0	0
Total expected power (MW)	26195.071	23519.591	20616.894	23519.591	20490.612	23519.591
Expected inflow (€)	684350.67	607650.89	604799.61	567634.54	576688.69	552409.90
Expected costs (€)	0	87673.49	0	90109.12	0	89339.00
Expected revenue (€)	684350.67	519977.40	604799.61	477525.42	576688.69	463070.90

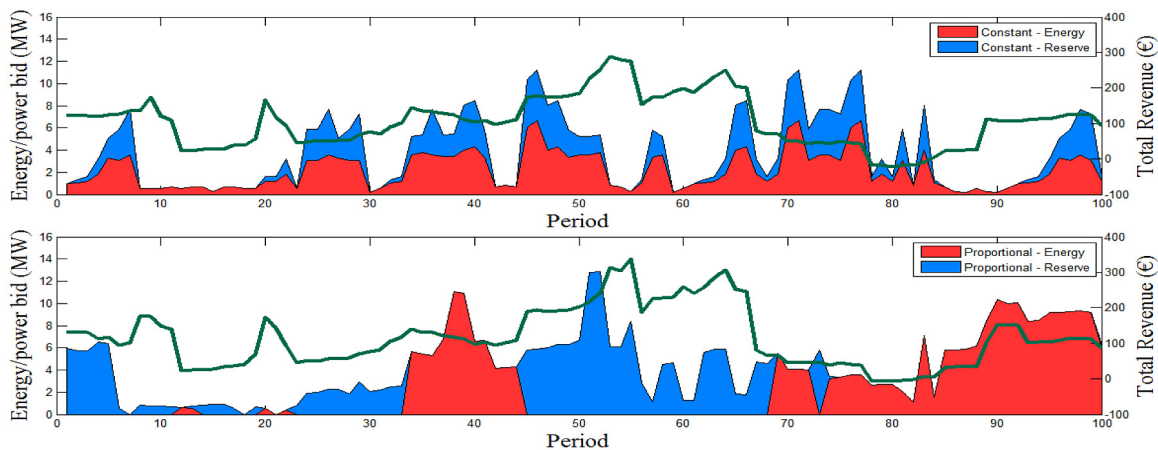

Fig. 9. Constant and proportional strategies behavior over the time, under real data adapted from [13].

between the expected inflow and expected costs (defined in Sect. IV). The energy-only strategy is based on the common newsvendor problem [13]. Thus, the quantile for this strategy is given by Eq. (29). Observing the behavior of the strategies in Table III, one can verify that constant strategy has higher expected return than the other strategies.

2) *Full Reserve Case*: Assuming that  $\lambda^{cap}$  is much larger than  $\lambda^{sp}$ , for instance  $\lambda^{cap} = 40$  €/MW, the strategies may split the energy and reserve bids differently. Table IV compare the strategies participation in both energy and primary reserve market for this capacity price.

One can verify that there is a change in the behavior of both proposed strategies. Both strategies allocate all the available energy to the primary reserve market. This is since the revenue from the primary reserve market is much higher than the revenue from the energy market. Both proposed strategies get better results than the energy-only strategy.

### B. Constant Strategy Behavior

1) *Objective Function Behavior*: The objective function for the base case is depicted in Fig. 6. One can verify that this function is convex, allowing to obtain a unique optimal solution. The expected reserve bid can never be higher than the total expected energy, hence the triangular cutoff for higher expected reserve.

2) *Constant Strategy Performance Under Different Spot and Primary Reserve Market Prices*: The behavior of the constant strategy strongly depends on the difference between day-ahead energy and primary reserve market prices. Fig. 7 depicts the behavior of the strategy under different spot and reserve market

prices. The simulation is performed under the base case data with variation in spot and primary reserve prices.

The spot prices varies between 17 and 32 €/MWh, while the primary reserve market price is represented by three cases, 25, 35 and 50 €/MW, respectively.

The simulation shows that increasing primary reserve price leads to higher revenue, as expected. As long as the spot price increases, the expected revenue increases too, since the strategy splits its available power for energy and reserve. Thus, as long as one of the day-ahead energy spot or capacity price improves, the revenue tends to increase.

Fig. 8 illustrates the dependency of the share of the offers into the energy and reserve markets as a function of day-ahead energy and reserve capacity prices. The reserve share tends to reduce with the increase of the spot price, as expected. However, at a certain point, the reserve market no longer generates higher profit than the energy market, making that full availability is submitted to the energy market. This occurs when the spot price is higher than 25 €/MWh. In case 1 (reserve price of 25 €/MW) this occurs because the primary reserve penalty is higher than the energy penalty, so there is no incentive to participate in the primary reserve market. The intersection between energy and reserve curve for case 1, gives precisely the result of the base case for the constant strategy.

### C. Strategies Behavior Over Time—Real Data

The data and assumptions used for simulation of both strategies over time are the same used in [13]. We consider a wind farm of 15 MW participating in the Nord Pool, where the wind

farm data is based on power measurements and a series of 48 h-ahead point predictions between March 2001 and April 2003 [13]. Nord Pool prices and penalties between 2001 and 2003 are used. Reserve penalty is assumed to be 50% higher than the capacity price in the primary reserve market.

The cumulative data results for energy and revenue over the two years for each strategy are shown in Table V. In overall, one can see that the proportional strategy submits more power to the energy and reserve markets than the constant strategy. In the same perspective, the proportional strategy gets more expected revenue than constant strategy. Furthermore, proportional and constant strategies improve the revenue of wind power producers relative to the energy-only strategy by about 12% and 3%, respectively. In addition, Table V provides a comparison for each strategy between the expected results under forecast scenarios and under deployed wind power.

Fig. 9 illustrates the different behavior of both proportional and constant strategies over time. It can be seen that in most of the periods, the constant strategy splits the available power for participation in both markets. On contrary, the proportional strategy tends to submit all the available power to one market only. From the economic point of view, both strategies are balanced. I.e., in some periods, the constant strategy may get more revenue than the proportional one, however, the opposite also occur. This is because of the different assumptions on the formulation of each strategy, yielding different behavior in the market.

## VI. CONCLUSION

The increasing flexibility of wind power plants will allow them to provide more market services, such as primary reserve, in the future.

This work formulates and derives optimal offering strategies for wind power plants participation in energy and primary reserve markets. Two strategies (proportional and constant reserve offering strategies) were considered. Both strategies have different behavior and flexibility, however, they increase wind power owners expected profits as compared to an energy-only bid. The results show that such strategies provide additional profits in expectation. The proportional strategy leads to a binary behavior where all the available energy is submitted in either the energy or the reserve market. In contrast, the constant strategy enables a joint participation of wind power plants in both energy and primary reserve markets. In addition, results show that these offering strategies strongly depend on the market prices and penalties for energy and primary reserve. An important conclusion from this work is that, even though turbines may have the technical ability to provide reserves, they may not always do so in the current market framework, since the relative profitability and penalties in both energy and reserve markets will drive the behavior of wind power producers.

Future work will focus on improvements of the strategies considering that the share for energy and reserve submitted in the day-ahead market can change in the balancing market.

## ACKNOWLEDGMENT

The authors would like to thank three reviewers whose comments allowed to improve the contents and presentation of this work.

## REFERENCES

- [1] Energinet.dk. (2014). "Annual report 2013," pp. 1–139, 2014, [Online]. Available: <https://www.energinet.dk/SiteCollectionDocuments/Engelske%20dokumenter/Om%20os/Annual%20Report%202013.pdf>
- [2] Danish Government, "Energy strategy 2050–From coal, oil and gas to green energy," Danish Energy Agency, pp. 1–66, 2011 [Online]. [http://www.ens.dk/sites/ens.dk/files/dokumenter/publikationer/downloads/energy\\_strategy\\_2050.pdf](http://www.ens.dk/sites/ens.dk/files/dokumenter/publikationer/downloads/energy_strategy_2050.pdf)
- [3] M. A. Ortega-Vazquez and D. S. Kirschen, "Estimating the spinning reserve requirements in systems with significant wind power generation penetration," *IEEE Trans. Power Syst.*, vol. 24, no. 1, pp. 114–124, Feb. 2009.
- [4] E. Ela, B. Kirby, N. Navid, and J. C. Smith, "Effective ancillary services market designs on high wind power penetration systems," in *Proc. IEEE Power Energy Soc. Gen. Meeting*, 2012, pp. 1–8.
- [5] H. Lund *et al.*, "System and market integration of wind power in Denmark," *Energy Strategy Rev.*, vol. 1, pp. 143–156, 2013.
- [6] Y. Dvorkin, M. A. Ortega-Vazquez, and D. S. Kirschen, "Wind generation as a reserve provider," *IET Gener. Transm. Distrib.*, vol. 9, no. 8, pp. 779–787, 2015.
- [7] D. Nock, V. Krishnan, and J. D. McCalley, "Dispatching intermittent wind resources for ancillary services via wind control and its impact on power system economics," *Renew. Energy*, vol. 71, pp. 396–400, 2014.
- [8] G. Michalke and A. D. Hansen, "Grid support capabilities of wind," in *Handbook of Wind Power Systems*. New York, NY, USA: Springer, pp. 569–590, 2014.
- [9] L. Zeni, A. J. Rudolph, J. Münster-Swendsen, I. Margaritis, A. D. Hansen, and P. Sørensen, "Virtual inertia for variable speed wind turbines," *Wind Energy*, vol. 16, pp. 1225–1239, 2013.
- [10] R. Doherty and M. O'Malley, "A new approach to quantify reserve demand in systems with significant installed wind capacity," *IEEE Trans. Power Syst.*, vol. 20, no. 2, pp. 587–595, May 2005.
- [11] B. Kirby, M. Milligan, and E. Ela, "Providing minute-to-minute regulation from wind plants," in *Proc. 9th Annu. Int. Workshop Large-Scale Integr. Wind Power Power Syst. Transm. Netw. Offshore Wind Power Plant*, Quebec, Canada, pp. 1–11, Oct., 2010.
- [12] J. Liang, S. Grijalva, and R. G. Harley, "Increased wind revenue and system security by trading wind power in energy and regulation reserve markets," *IEEE Trans. Sustain. Energy*, vol. 2, no. 3, pp. 340–347, Jul. 2011.
- [13] P. Pinson, C. Chevallier, and G. N. Kariniotakis, "Trading wind generation from short-term probabilistic forecasts of wind power," *IEEE Trans. Power Syst.*, vol. 22, no. 3, pp. 1148–1156, Aug. 2007.
- [14] J. Usaola and M. Á. Moreno, "Optimal bidding of wind energy in intraday markets," in *Proc. 6th Int. Conf. Eur. Energy Market (EEM'09)*, 2009, pp. 1–7.
- [15] J. M. Morales, S. Member, A. J. Conejo, and J. Pérez-ruiz, "Short-term trading for a wind power producer," *IEEE Trans. Power Syst.*, vol. 25, no. 1, pp. 554–564, Feb. 2010.
- [16] A. Botterud *et al.*, "Wind power trading under uncertainty in LMP markets," *IEEE Trans. Power Syst.*, vol. 27, no. 2, pp. 894–903, May 2012.
- [17] E. Y. Bitar, R. Rajagopal, P. P. Khargonekar, K. Poolla, and P. Varaiya, "Bringing wind energy to market," *IEEE Trans. Power Syst.*, vol. 27, no. 3, pp. 1225–1235, Aug. 2012.
- [18] M. Zugno, T. Jónsson, and P. Pinson, "Trading wind energy on the basis of probabilistic forecasts both of wind generation and of market quantities," *Wind Energy*, vol. 16, no. 6, pp. 909–926, 2013.
- [19] M. Vilim and A. Botterud, "Wind power bidding in electricity markets with high wind penetration," *Appl. Energy*, vol. 118, pp. 141–155, 2014.
- [20] C. J. Dent, J. W. Bialek, and B. F. Hobbs, "Opportunity cost bidding by wind generators in forward markets: Analytical results," *IEEE Trans. Power Syst.*, vol. 26, no. 3, pp. 1600–1608, Aug. 2011.
- [21] J. Matevosyan and L. Söder, "Minimization of imbalance cost trading wind power on the short-term power market," *IEEE Trans. Power Syst.*, vol. 21, no. 3, pp. 1396–1404, Aug. 2006.



- [22] M. Zugno, J. M. Morales, P. Pinson, H. Madsen, and A. Sets, "Pool strategy of a price-maker wind power producer," *IEEE Trans. Power Syst.*, vol. 28, no. 3, pp. 3440–3450, Aug. 2013.
- [23] L. Baringo and A. J. Conejo, "Strategic offering for a wind power producer," *IEEE Trans. Power Syst.*, vol. 28, no. 4, pp. 4645–4654, Nov. 2013.
- [24] S. J. Kazempour and H. Zareipour, "Equilibria in an oligopolistic market with wind power production," *IEEE Trans. Power Syst.*, vol. 29, no. 2, pp. 686–697, Mar. 2014.
- [25] K. C. Sharma, R. Bhakar, and H. P. Tiwari, "Strategic bidding for wind power producers in electricity markets," *Energy Convers. Manage.*, vol. 86, pp. 259–267, 2014.
- [26] L. Baringo and A. J. Conejo, "Offering strategy of wind-power producer: A multi-stage risk-constrained approach," *IEEE Trans. Power Syst.*, 2015, pp. 1–10, doi: 10.1109/TPWRS.2015.2411332.
- [27] T. Dai, S. Member, W. Qiao, and S. Member, "Optimal bidding strategy of a strategic wind power producer in the short-term market," *IEEE Trans. Sustain. Energy*, vol. 6, no. 3, pp. 707–719, Jul. 2015.
- [28] M. Shafie-khah, A. A. S. de la Nieta, J. P. S. Catalão, and E. Heydarian-Forushani, "Optimal self-scheduling of a wind power producer in energy and ancillary services markets using a multi-stage stochastic programming," in *Proc. Smart Grid Conf. (SGC)*, 2014, pp. 1–5.
- [29] Y. Wang, "Evaluation de la performance des réglages de fréquence des éoliennes à l'échelle du système électrique: Application à un cas insulaire," (in French), Ph.D. dissertation, L2EP, Ecole Centrale de Lille, Villeneuve-d'Ascq, France, 2012.
- [30] Y. Wang, H. Bayem, M. Giralt-Devant, V. Silva, X. Guillaud, and B. Francois, "Methods for assessing available wind primary power reserve," *IEEE Trans. Sustain. Energy*, vol. 6, no. 1, pp. 272–280, Jan. 2015.
- [31] S. Krohn, P. E. Morthorst, and S. Awerbuch, "The economics of wind energy," *EWEA–Eur. Wind Energy Assoc.*, pp. 1–156, 2009 [Online]. Available: [http://www.ewea.org/fileadmin/files/library/publications/reports/Economics\\_of\\_Wind\\_Energy.pdf](http://www.ewea.org/fileadmin/files/library/publications/reports/Economics_of_Wind_Energy.pdf)
- [32] Energinet.dk, "Wind power to combat climate change—How to integrate wind energy into the power system," pp. 1–56, 2009 [Online]. Available: <http://energinet.dk/SiteCollectionDocuments/Engelske%20dokumenter/Klimaogmiljo/Wind%20power%20magazine.pdf>
- [33] K. Skytte, "The regulating power market on the Nordic power exchange nord pool: An econometric analysis," *Energy Econ.*, vol. 21, no. 4, pp. 295–308, 1999.
- [34] Energinet.dk, "Regulation C2: The balancing market and balance settlement," Doc. no. 251673-06, pp. 1–20, 2008 [Online]. Available: <https://www.energinet.dk/SiteCollectionDocuments/Engelske%20dokumenter/El/Regulation%20C2%20The%20balancing%20market%20and%20balance%20settlement.pdf>
- [35] A. J. Conejo, M. Carrión, and J. M. Morales, *Decision Making Under Uncertainty in Electricity Markets*. New York, NY, USA: Springer, 2010.
- [36] H. Raiffa and R. Schlaifer, *Applied Statistical Decision Theory*. Boston, MA, USA: Division of Research, Harvard Business School, 1961.
- [37] B. Kirby and A. Tuohy, "Profitability of wind plants providing ancillary services—Regulation and spinning reserve," 2013 [Online]. Available: [http://www.nrel.gov/electricity/transmission/pdfs/wind\\_workshop2\\_24kirby.pdf](http://www.nrel.gov/electricity/transmission/pdfs/wind_workshop2_24kirby.pdf)



**Tiago Soares** received the B.Sc. and M.Sc. degrees in electrical engineering from the School of Engineering, Polytechnic Institute of Porto, Porto, Portugal, in 2010 and 2013, respectively. He is currently pursuing the Ph.D. degree at the Technical University of Denmark, Kgs. Lyngby, Denmark. His research interests include electricity markets, distributed generation, energy resources management and optimization under uncertainty, and future power systems.



**Pierre Pinson** (M'11–SM'13) received the M.Sc. degree in applied mathematics from the National Institute for Applied Sciences (INSA), Toulouse, France, and the Ph.D. degree in energetics from Ecole des Mines de Paris, Paris, France. He is a Professor with the Department of Electrical Engineering, Centre for Electric Power and Energy, Technical University of Denmark, Kgs. Lyngby, Denmark, also heading a group focusing on Energy Analytics and Markets. His research interests include forecasting, uncertainty estimation, optimization under uncertainty, decision sciences, and renewable energies. He is an Editor for the *IEEE TRANSACTIONS ON POWER SYSTEMS* and the *International Journal of Forecasting* and for *Wind Energy*.

uncertainty, decision sciences, and renewable energies. He is an Editor for the *IEEE TRANSACTIONS ON POWER SYSTEMS* and the *International Journal of Forecasting* and for *Wind Energy*.



**Tue V. Jensen** received the M.Sc. degree in physics from Aarhus University, Aarhus, Denmark, in 2013. He is currently pursuing the Ph.D. degree at the Technical University of Denmark, Kgs. Lyngby, Denmark. His research interests include renewable energy markets, complex networks, and gaming aspects of energy markets.



**Hugo Morais** (S'08–M'11) received the Ph.D. degree in electrical engineering from the University of Trás-os-Montes e Alto Douro, Vila Real, Portugal. He is a Researcher with the *Mesures et système d'Information des Réseaux Electriques* Group, *Électricité de France*, Clamart, France. His research interests include distributed energy resources management, virtual power players, smart grids, future power systems, agents technology, and power systems visualization.



APPENDIX **D**

# Paper D

---

**Title:**

Wind offering in energy and reserve markets

**Authors:**

Tiago Soares, Pierre Pinson and Hugo Morais

**Published in:**

Journal of Physics: Conference Series. Proceedings of WindEurope Summit (2016),  
DOI: [dx.doi.org/10.1088/1742-6596/749/1/012021](https://doi.org/10.1088/1742-6596/749/1/012021).

## Wind offering in energy and reserve markets

T Soares<sup>1a</sup>, P Pinson<sup>2a</sup>, H Morais<sup>3b</sup>

<sup>a</sup>Technical University of Denmark, Elektrovej B. 329A, 2800 Kgs. Lyngby, Denmark

<sup>b</sup>Polytechnic Institute of Porto, Porto, Portugal

<sup>1</sup>tiasoar@elektro.dtu.dk, <sup>2</sup>ppin@elektro.dtu.dk, <sup>3</sup>hugvm@isep.ipp.pt

**Abstract.** The increasing penetration of wind generation in power systems to fulfil the ambitious European targets will make wind power producers to play an even more important role in the future power system. Wind power producers are being incentivized to participate in reserve markets to increase their revenue, since currently wind turbine/farm technologies allow them to provide ancillary services. Thus, wind power producers are to develop offering strategies for participation in both energy and reserve markets, accounting for market rules, while ensuring optimal revenue. We consider a proportional offering strategy to optimally decide upon participation in both markets by maximizing expected revenue from day-ahead decisions while accounting for estimated regulation costs for failing to provide the services. An evaluation of considering the same proportional splitting of energy and reserve in both day-ahead and balancing market is performed. A set of numerical examples illustrate the behavior of such strategy. An important conclusion is that the optimal split of the available wind power between energy and reserve strongly depends upon prices and penalties on both market trading floors.

### 1. Introduction

In last two decades electricity markets have been evolving in different ways with the aim to improve the competition among the different players without compromising the required reliability and stability in the electric system. In this scope, electricity markets are composed by different market stages for different commodities. Besides the energy commodity traded in energy auctions, there are ancillary services commodities (usually traded in reserve markets) that are used by power system operators to ensure proper levels of reliability, stability and security in the power system.

With the continuous introduction of wind generation in the electricity market, the behavior of electricity market participants has been changing. Currently, multiple methodologies for optimizing the strategic behavior of wind power producers (WPP) in the energy market have been proposed, accounting for expected costs from the balancing market [1–8]. Part of this work has been conducted based on the assumption that the strategic behavior of wind power plants does not have a significant impact on the market equilibrium, thereby, assuming price-taker behavior, i.e. the WPP does not exert market power [1–5]. In an opposite direction, several works exist, claiming that WPP may have a significant impact in the market equilibrium, and somehow may exert market power – yielding a price-maker assumption [6–8].

Nevertheless, wind power generators are now able to provide ancillary services, such as frequency and voltage control [9]. Namely, wind power plants can control active power injection in a few seconds; injecting/consuming reactive power while maintaining proper voltage levels, as well as providing virtual inertia to the system [10–12]. Thus, new business models may emerge, stimulating



the willingness of wind power producers to participate and take advantage of reserve markets to increase their profit, as detailed in [13–15]. A analytical approach based on probabilistic forecast for wind power participating in the energy and reserve market is proposed in [13,14]. In [13], a simplistic strategy for splitting the available wind power in energy and reserve is applied, while [14] uses two different control strategies (proportional and constant wind power control) for WPP to participate in both energy and reserve markets.

We place ourselves under the proportional control strategy used in [14], contributing with a new stochastic methodology that maximizes the expected revenue of the WPPs in the day-ahead energy market and in the reserve market, while accounting for expected costs from failing to provide the energy and reserve products at the balancing stage. Besides that, this work contributes with a new perspective of facing the lead time of the WPP between the day-ahead and balancing stage by considering that energy and reserve bids submitted in the day-ahead market by the WPPs can be changed in the balancing market, i.e. the use of more accurate forecast of the wind power production in the balancing stage reduces the deviation between the power production committed in day-ahead stage and the effective production during the energy delivery. This may allow WPPs to bid in both market stages with more precise information about their wind power production, thereby, reducing expected energy and reserve costs in the balancing market. The results show that allowing a change in the proportionality of energy and reserve between day-ahead and balancing market, improves the expected revenues of the WPP, as well as, reduces the expected power deviation between the day-ahead and the energy delivery.

The paper is structured as follows. Section 2 describes the market structure for wind power producers participating in energy and reserve markets. Section 3 presents the detailed mathematical formulation of the optimal offering strategy for wind power producers. Section 4 numerically evaluates the offering strategy in expectation under different prices and penalties schemes that may occur in the market. Section 5 assembles the most important conclusions.

## **2. Wind power in electricity markets**

### *2.1. Day-ahead and balancing participation*

Currently, wind power producers can participate in the wholesale market by submitting their power bids (usually, their expected production) in the day-ahead market. The uncertainty of the wind power production is usually mitigated through the balancing market (the last mechanism for correcting the system and market participant imbalances), where the deviations of the wind power producers (the difference between their day-ahead market bids and the expected power production close to real-time) may induce some penalties for the wind power producers by failing to provide their day-ahead bids (either in deficit or surplus of power production) [16,17].

In that context, the expected costs to the wind power producers depend on the energy imbalance of the power system and of the difference between the sell and the delivered energy by the WPP. Furthermore, two different penalty mechanisms (one-price settlement and two-price settlement) can be applied depending on the characteristics and of the market rules [18,19]. For instance, the two-price system is assumed in the balancing mechanism in Denmark [20].

In what concerns the price bids of wind power plants in the day-ahead market, usually, WPPs places their power bids in the market at zero price or even negative price. This behavior depends on the internal rules of each market, as well as, on the different incentive schemes that wind power producers are submitted in each country. For instance, in Denmark, wind power producers are remunerated based on a scheme that lies on a combination of market participation (negative prices are allowed in NordPool) plus a premium [14]. In Portugal, similar schemes have been followed, yet most of wind power producers are still under fixed feed-in tariffs [21]. Besides, the Iberian market does not allow for negative bids [22,23].



2.2. Energy and reserve markets model

WPPs are willing to provide some ancillary services, since in their perspective, providing reserve (even with uncertainty and under high penalties when failing to provide the service) can somehow increase their revenue. Thus, the development of a methodology for wind power participation in energy and reserve markets at the day-ahead market, while accounting with expected costs in the balancing market is proposed and illustrated in Figure 1. The energy and reserve markets assume different characteristics, so different considerations are taken. On the one hand, wind energy bids submitted in the day-ahead market should account for potential imbalance situations and their asymmetric penalties. On the other hand, bids submitted in the reserve market should take into account the possibility to fail in providing the service.

Nevertheless, this model allows WPPs to submit bids into the energy and reserve market at day-ahead stage, following a proportional strategy for the split of the available power into energy and reserve (a share parameter is obtained by the split between energy and reserve). The bidding strategy for the day-ahead market assumes an expected energy market price, while the reserve market participation strategy takes into account the capacity reserve price.

At the balancing stage, expected costs for energy and reserve deviations are considered. On the one hand, expected costs for energy surplus or deficit of the WPP are considered. In contrast, reserve costs are only accounted for deficit of reserve, since the reserve surplus is not detrimental to the system. Additionally, this models assumes that the share parameter (split between energy and reserve) at the balancing stage can assume a different value from the one used for the day-ahead market decision. Thus, WPPs have the opportunity to reduce some energy or reserve deviations, thereby, increasing its expected revenue.

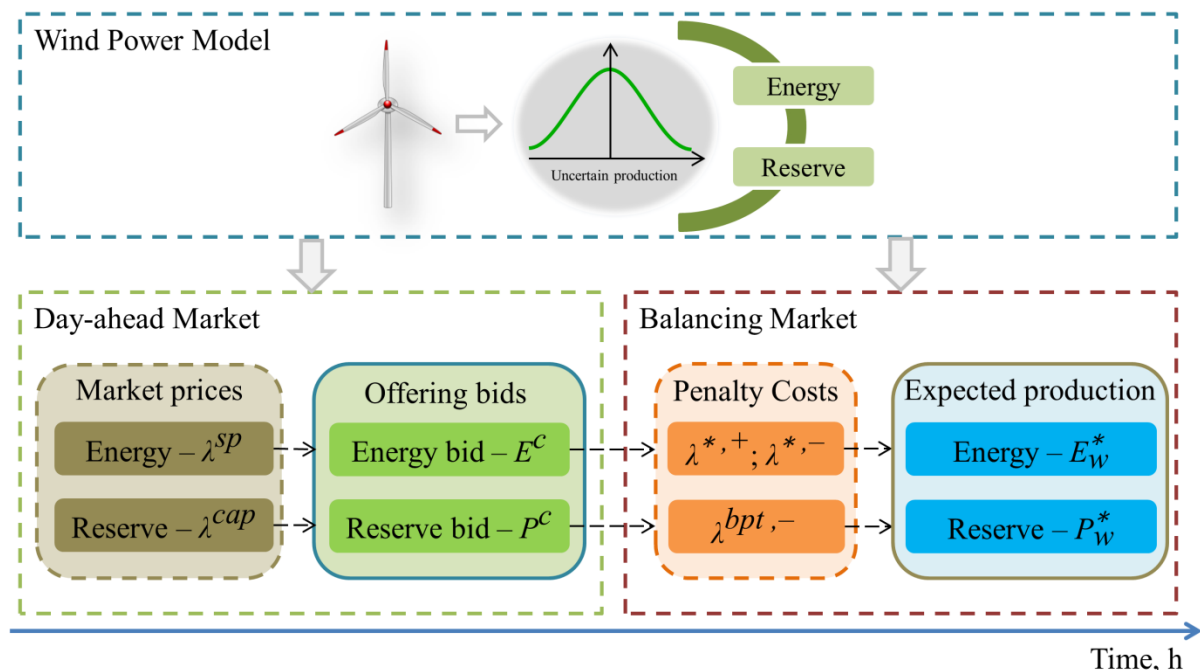

Figure 1. Wind power participation model in the energy and reserve market.

2.3. Wind power control to provide energy and reserve

Currently, wind power plants have developed several ways of active power control to provide energy and reserve, thereby, ensuring the stability of the power system. The use of these controls has been required by the system operators in different countries with high penetration of wind power, thereby, updating the grid-codes with new active power controls methodologies. System operators may require the use of such controls in cases of excess of wind power, to decrease congestion or even just for

reserve provision. In this context, four methods for active power control of wind power for providing energy and reserve are described in detail.

**2.3.1. Proportional wind control.** This control mechanism consists in the proportional split of the available active power in energy and reserve, as illustrated in Figure 2. In terms of market strategy, the proportional wind offering strategy is used to define the share of energy  $E^c$  and reserve  $P^c$  to be submitted in the market [14,24], where  $Q$  is the total power bid and  $\alpha^c$  the strategy parameter controlling the share of energy and reserve bids at day-ahead stage, which varies between 0 and 1.

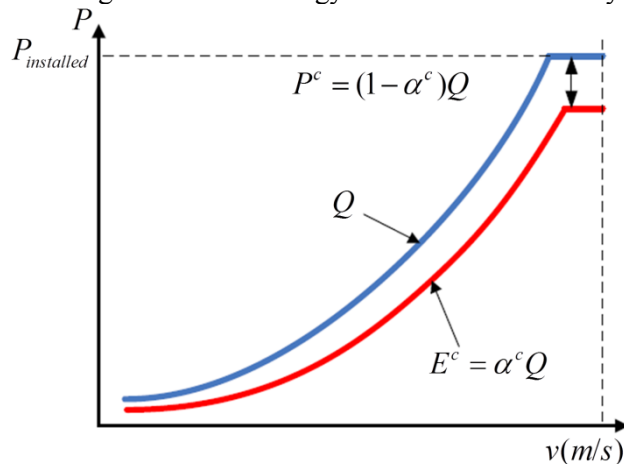

**Figure 2.** Proportional wind offering strategy (reproduced with authorization from [24]). The blue line  $Q$  stands for the available wind power production, while the red curve  $E^c$  comprises the energy part of  $Q$  to offer in the energy market. The reserve bid  $P^c$  to offer in the reserve market is equal to area between the blue and red curve.  $\alpha^c$  is the proportional share parameter that splits the available wind power into energy and reserve assuming a value between 0 and 1.

**2.3.2. Constant wind control.** The constant wind power consists in a constant curtailment of energy in case that the expected forecast is bigger than a specified level of wind power (Figure 3) [14,24]. The strategy, reserves a fixed amount of power reserve to face system imbalances. The remaining active power is dispatched for the energy service. In this control, wind power plant has a fixed amount of power reserve for ancillary services, when the wind power available is above of a certain percentage  $X\%$  of the installed wind power. Otherwise, the available wind power is offered to the energy market.

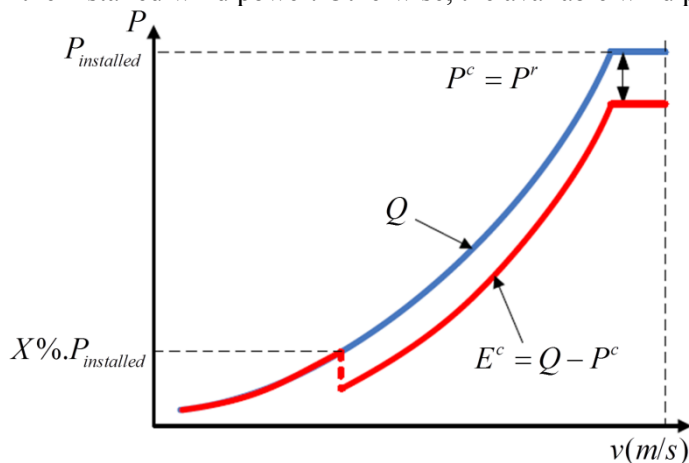

**Figure 3.** Constant wind offering strategy (reproduced with authorization from [24]). The blue line  $Q$  stands for the available wind power production, while the red curve  $E^c$  is the remaining part of  $Q$  to offer in the energy market assuming a certain fixed amount of reserve  $P^c$ .

**2.3.3.  $\Delta P$  control.** This control is similar to the constant wind power control. The control curtails a certain and fixed amount of the maximum available power in function of the system operator requirements [15,25,26]. The biggest difference between the  $\Delta P$  control and the constant control is the use of a minimum threshold ( $X\%$  of the installed wind power) in the constant control to allocate part of the available wind power as power reserve.

**2.3.4. Output cap.** The output cap is an active power control for wind turbines establishing a maximum level of active power that can be provided to the energy service [15]. In cases of the

available wind power higher than the output cap, the power that exceeds the output cap is curtailed by the wind turbine. Thus, system operator can require low levels of output cap to decrease the variability of the wind power production. However in the WPP standpoint, this control most likely reserves a significant part of the available energy to power reserve, which may result in a small but somehow constant provision of the energy service.

### 3. Wind offering methodology

#### 3.1. General optimization framework

A methodology for the optimal offering of a WPP in energy and reserve markets at the day-ahead stage, while accounting for the expected penalties in the balancing market is proposed. A two-stage stochastic approach is used to optimize the revenue  $R$  for a given WPP, and is expressed as

$$\underset{Q, \alpha^c, \alpha_w^*}{\text{Maximize}} R = \lambda^{cap} P^c + \sum_{w \in \Omega} \pi_w \left[ \lambda^{sp} E_w^* - T_w^* - W_w^* \right] \quad (1)$$

where  $\lambda^{cap}$  is the capacity price for primary reserve allocation,  $P^c$  is the reserve contracted (offered) in the day-ahead market,  $\lambda^{sp}$  is the spot price,  $E_w^*$  is the delivered energy in scenario  $w$ ,  $T_w^*$  is the regulation costs from the regulation market, and  $W_w^*$  is the penalty cost for wind power plant failing to provide the scheduled reserve.

Additionally, it is assumed that the WPP acts as a price-taker. Thus, the market prices and penalties are independent of the WPP production. Then, the regulation costs from the regulation market can be defined as

$$T_w^* = \begin{cases} \lambda^{*,+} (E_w^* - E^c), & E_w^* - E^c \geq 0 \\ -\lambda^{*,-} (E_w^* - E^c), & E_w^* - E^c < 0 \end{cases} \quad (2)$$

where  $(E_w^* - E^c)$  is the difference between the delivered energy  $E_w^*$  and the amount of energy offered at day-ahead market  $E^c$ . The variables  $\lambda^{*,+}$  and  $\lambda^{*,-}$  are the regulation unit costs for positive and negative deviations, respectively,

$$\begin{aligned} \lambda^{*,+} &= \lambda^{sp} - \lambda^{c,+} \\ \lambda^{*,-} &= \lambda^{c,-} - \lambda^{sp} \end{aligned} \quad (3)$$

where  $\lambda^{c,+}$  is the unit down-regulation price for being long, while  $\lambda^{c,-}$  is the up-regulation price for being short. In addition, a two-price settlement rule (as in NordPool) is assumed [1]. Thus, when the power system imbalance is negative, there is a need for downward regulation (energy surplus), which is given by

$$\begin{aligned} \lambda^{c,+} &\leq \lambda^{sp} \\ \lambda^{c,-} &= \lambda^{sp} \end{aligned} \quad (4)$$

On the other hand, when the power system imbalance is positive, there is a need for upward regulation so the prices and penalties hold that

$$\begin{aligned} \lambda^{c,+} &= \lambda^{sp} \\ \lambda^{c,-} &\geq \lambda^{sp} \end{aligned} \quad (5)$$

The penalty costs for reserve imbalance is given by

$$W_w^* = \begin{cases} \lambda^{bpt,+} (P_w^* - P^c), & P_w^* - P^c \geq 0 \\ -\lambda^{bpt,-} (P_w^* - P^c), & P_w^* - P^c < 0 \end{cases} \quad (6)$$

where  $(P_w^* - P^c)$  is the reserve power imbalance between the deployed level of reserve  $P_w^*$  in real-time and the reserve offered,  $\lambda^{bpt,+}$  is a unit penalty when wind producer generates more power than the contracted (surplus), and  $\lambda^{bpt,-}$  is the unit penalty cost when the WPP generate less than contracted. These are given by

$$\begin{aligned} \lambda^{bpt,+} &= \lambda^{cap} - \lambda^{pt,+} \\ \lambda^{bpt,-} &= \lambda^{pt,-} - \lambda^{cap} \end{aligned} \quad (7)$$

hence  $\lambda^{pt,+} = 0$  since (extra) positive reserve is not detrimental to the system's reliability.  $\lambda^{pt,-}$  is the penalty for negative reserve imbalance, weighted by the probability that reserve is needed.

### 3.2. Proportional wind offering strategy

In this work and by simplicity, the proportional wind offering strategy is applied for splitting the available wind power for energy and reserve, as illustrated in Figure 2. The objective function is subject to the following constraints regarding the proportional strategy split of energy and reserve. The proportional wind offering strategy is used to define the share of energy  $E^c$  and reserve  $P^c$  to be submitted in the market [14,24].

$$E^c = \alpha^c Q \quad (8)$$

$$P^c = (1 - \alpha^c) Q \quad (9)$$

$$1 \leq Q \leq E^{\max} \quad (10)$$

Under some support schemes, the WPPs are required to participate in the day-ahead market, thereby, the bounds of the total power bid  $Q$  reflects the minimum power bid to participate in the market (1 MW in most of electricity markets) and the installed capacity of the WPP.

Equations (11) and (12) concerns the wind offering strategy under the balancing power market

$$E_w^* = \alpha_w^* E_w^{obs}, \quad \forall w \in \Omega \quad (11)$$

$$P_w^* = (1 - \alpha_w^*) E_w^{obs}, \quad \forall w \in \Omega \quad (12)$$

where  $E_w^{obs}$  donates the eventually observed wind power production, composed by energy  $E_w^*$  and reserve  $P_w^*$  share actually available.  $\alpha_w^*$  is the strategy parameter for the splitting in real-time operation.

### 3.3. Fixed and relaxed approach of wind strategic split in day-ahead and balancing market

Under the fixed approach (problem with “non-anticipativity” constraints), it is assumed that the share of energy and reserve established in the balancing stage cannot be different from the day-ahead stage. This ensures that perfect information on real-time cannot be used to change the share of energy and reserve decided on the first-stage problem, thereby avoiding the decision process to play with full degree of freedom. Equation (13) represents the “non-anticipativity” constraint of the wind offering problem.

$$\alpha_w^* = \alpha^c, \quad \forall w \in \Omega \quad (13)$$

On the other hand, a simplification of the proportional strategy in the stochastic problem can be performed, assuming that the wind power producer can change the share of energy and reserve in both

day-ahead and balancing stages (relaxed approach). This means that the wind power producer can adjust the share of energy and reserve in real-time, accordingly with the expected power production in each scenario  $w$ . Thus, the WPP can improve their revenue by changing their bid according with better information of their production when closer to real-time operation. The mathematical formulation for that case relies on equations (1) to (12).

The wind power producer problem presented here has been modelled as two-stage stochastic approach in GAMS [27] modelling language and carried out with CONOPT [28] as a NLP solver on an Intel Core i5 2.70 GHz processor with 8 GB RAM.

#### 4. Evaluation of offering strategies

A wind power plant with 15 MW of installed power is considered. The wind total bid offer is subjected to a minimum amount of power to participate in the markets. Currently, electricity markets settle 1 MW as the minimum power for the bidding process. A set of 100 wind power scenarios for a single period presented in [29], has been considered for evaluating the proposed methodology. It is assumed that all the scenarios have equal probability.

The evaluation of the proposed strategy is performed according with a set of prices and penalty costs combination allowing us to test the behavior of the strategy for different assumptions, such as  $\alpha_w^* = \alpha^c$  and allowing that  $\alpha_w^*$  can be free (i.e.,  $\alpha_w^*$  can be equal or different of  $\alpha^c$ ) – stochastic approach with and without “non-anticipativity” constraint.

##### 4.1. Normal operation

Under normal operation in the electricity market, adequate price signals for wind participate in both energy and reserve markets should be ensured. In this scope, the capacity price in the day-ahead market should be higher than the spot price ( $\lambda^{cap} \geq \lambda^{sp}$ ). Besides that, the reserve penalties in the balancing stage for failing to provide the bid offered in the day-ahead stage should be higher than the penalty for failing to provide the energy ( $\lambda^{bpt,-} \geq \lambda^{*,-}$ ), since for the power system is much worse a unit failing to provide reserve rather than energy.

Thus, the prices for energy and reserve, and the unit penalty costs for up and down deviations under normal operation for the power system (our base case) are presented in Table 1.

**Table 1.** Prices and penalty costs in energy and reserve market for base case.

Energy	Price (€/MWh)	Reserve	Price (€/MW)
$\lambda^{sp}$	40	$\lambda^{cap}$	41
$\lambda^{c,+}$	30	$\lambda^{bpt,+}$	0
$\lambda^{c,-}$	50	$\lambda^{pt,-}$	96

Under the normal operation case, it is expected that both strategies may behave differently, since the allocation of the available energy to one of the markets is not straightforward. One can expect the strategy with fixed share parameter base their decision with the information available in the day-ahead stage, while the approach with the flexible share parameter may use the better information of the balancing stage to reduce expected costs. Figure 4 illustrates the energy market participation for both stochastic approaches with standard and flexible share parameter relationships between day-ahead and balancing market. The standard approach chooses to participate only in the energy market, since the gain from participating in the reserve market is not much higher than participating in energy-only, and account with a high penalty when failing to provide the offered power reserve (risk adverse behavior). In contrast, the flexible approach (without “non-anticipativity” constraint) presents a different behavior (closer to the risk neutral), since participating in both energy and reserve markets. The participation in both energy and reserve can in one way give flexibility to the wind power producer to

increase the expected revenue while taking the risk of getting penalties from failing to provide energy and reserve. Thus, for lower levels of available wind power (until wind available power equal to  $P^c$ , as can be seen in Figure 5) it is allocated all the available power to the reserve market ( $E^*=0$ , in Figure 4), where the penalty for failing is higher.

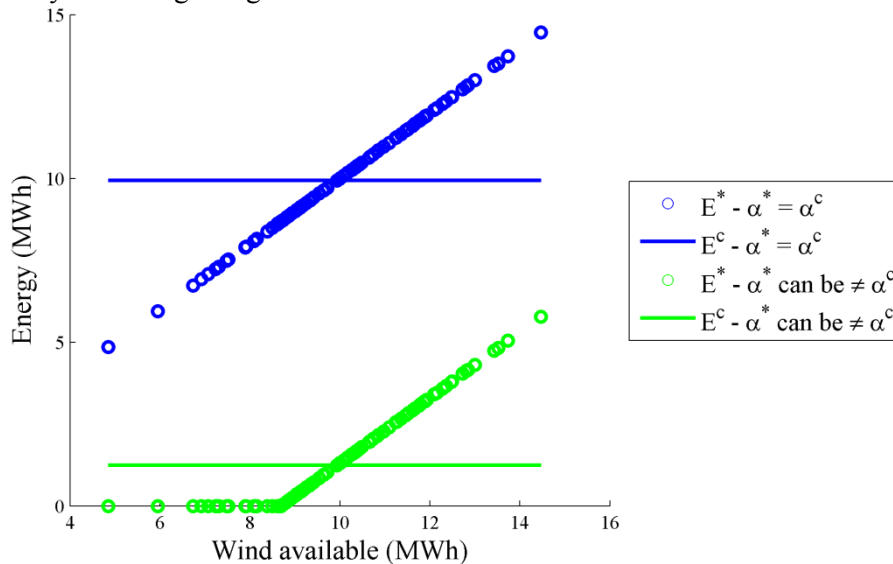

**Figure 4.** Energy bid in the day-ahead ( $E^c$ ) and balancing stage ( $E^*$ ) for both approaches under the normal operation case.

The reserve bids in day-ahead and balancing stage for both strategies are shown in Figure 5.

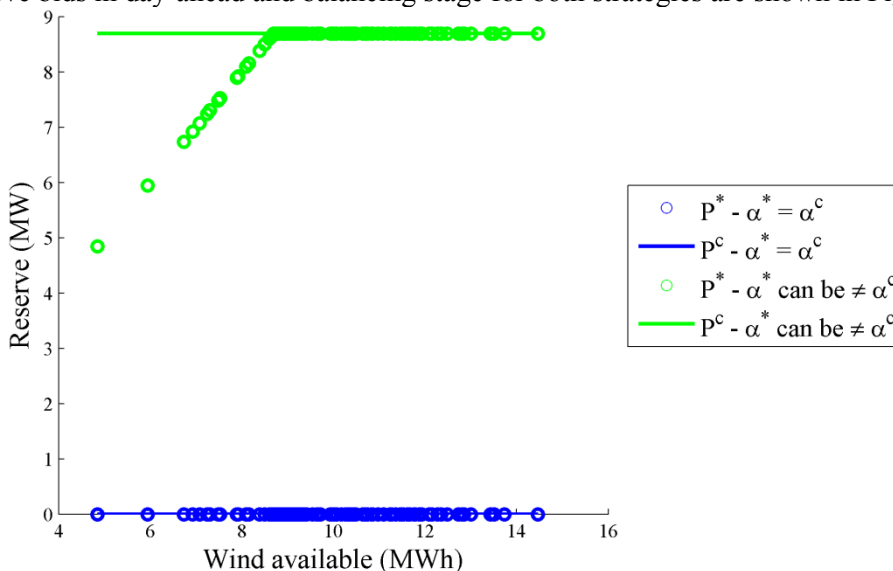

**Figure 5.** Reserve bid in the day-ahead ( $P^c$ ) and balancing stage ( $P^*$ ) for both approaches under the normal operation case.

Moreover, the expected revenue that the WPPs may achieve by participating in energy and reserve market with different behavior of the share between energy and reserve in day-ahead and balancing market is 387 € and 395 €, respectively. In this case, the opportunity to change the energy and reserve share in the balancing market improves the revenue of the WPPs about 2%.

#### 4.2. Special operation – single market participation

In cases of occur different schemes of prices and penalties, the participation in the market behaves differently, as expected. For instance, in cases where the capacity price is higher than the spot price ( $\lambda^{cap} \geq \lambda^{sp}$ ) and the reserve penalty lower than the energy penalty ( $\lambda^{bpt,-} \leq \lambda^{*,-}$ ), both strategies fully offers in the reserve only market. In this case, make total sense to offer only in the reserve market since there is no gain on participating in the energy market.

On the opposite case, when the capacity price is lower than the spot price ( $\lambda^{cap} \leq \lambda^{sp}$ ) and the reserve penalty is higher than the energy penalty ( $\lambda^{bpt,-} \geq \lambda^{*,-}$ ), both strategies assumes the same behavior by participating in the energy only market. One can notice that participating in the energy market will results in higher revenues in the day-ahead market and less expected costs in the balancing stage.

Both special cases implies a logical participation in a single market, however, these cases are unlikely to happen in future electricity markets with competitive integration of wind power generation in the reserve market.

## 5. Conclusions

With the introduction of new business models where the WPPs can provide energy and reserve bids in the day-ahead market while accounting for the expected cost from the balancing market, new strategic bidding for WPPs is crucial to increase their profit.

This work presents two ways for WPPs to submit their bids in the energy and reserve markets based on the assumption of WPP behaving as a price-taker. One of the approaches considers fixed share of energy and reserve in the stochastic general problem, i.e. the share parameter in both day-ahead and balancing stages remains the same. The other approach sets the share parameter to be free between the day-ahead and balancing stages. Although the strategy with flexible share parameter can increase the revenue of the WPP, this requires a certain level of perfect information of the balancing stage, since the “non-anticipativity” constraint between first and second stage of the problem is not applicable in this case. However, this strategy allows the WPP to change their bids in the market when getting close to the market closure gate, where information of its available production is more reliable.

Notwithstanding, future electricity market may face some changes on this topic, since new behavior and market opportunities for WPPs may influence the market design and mechanisms specially in reserve markets. On the one hand, system operators can require some guarantees from the WPPs, controlling somehow the level of uncertainty in the reserve product and maintaining proper levels of system reliability. On the other hand, market operators must develop mechanisms to ensure a fair participation of all type of market participants in both energy and reserve products and avoiding market power. Pushing decisions close to real-time is of the most interest of WPPs, since it will improve the quality of their decisions and to some extent reduce the lead time effect between the day-ahead decisions and the energy and services delivered.

## References

- [1] Pinson P, Chevallier C and Kariniotakis G N 2007 Trading wind generation from short-term probabilistic forecasts of wind power *IEEE Trans. Power Syst.* **22** 1148–56
- [2] Dent C J, Bialek J W and Hobbs B F 2011 Opportunity cost bidding by wind generators in forward markets: analytical results *IEEE Trans. Power Syst.* **26** 1600–8
- [3] Morales J M, Conejo A J and Pérez-ruiz J 2010 Short-term trading for a wind power producer *IEEE Trans. Power Syst.* **25** 554–64
- [4] Matevosyan J and Söder L 2006 Minimization of imbalance cost trading wind power on the short-term power market *IEEE Trans. Power Syst.* **21** 1396–404
- [5] Botterud A, Zhou Z, Wang J, Bessa R J, Keko H, Sumaili J and Miranda V 2012 Wind Power Trading under Uncertainty in LMP Markets *IEEE Trans. Power Syst.* **27** 894–903

- [6] Baringo L and Conejo A J 2013 Strategic offering for a wind power producer *IEEE Trans. Power Syst.* **28** 4645–54
- [7] Zugno M, Morales J M, Pinson P, Madsen H and Sets A 2013 Pool strategy of a price-maker wind power producer *IEEE Trans. Power Syst.* **28** 3440–50
- [8] Kazempour S J and Zareipour H 2014 Equilibria in an oligopolistic market with wind power production *IEEE Trans. Power Syst.* **29** 686–97
- [9] Ela E, Kirby B, Navid N and Smith J C 2012 Effective ancillary services market designs on high wind power penetration systems *IEEE Power and Energy Society General Meeting* (San Diego, California) pp 1–8
- [10] Nock D, Krishnan V and McCalley J D 2014 Dispatching intermittent wind resources for ancillary services via wind control and its impact on power system economics *Renew. Energy* **71** 396–400
- [11] Zeni L, Rudolph A J, Münster-Swendsen J, Margaris I, Hansen A D and Sørensen P 2013 Virtual inertia for variable speed wind turbines *Wind Energy* **16** 1225–39
- [12] Michalke G and Hansen A D 2013 Grid support capabilities of wind turbines *Handbook of Wind Power Systems* ed M P Pardalos, S Rebennack, F M V Pereira, A N Iliadis and V Pappu (Berlin, Heidelberg: Springer Berlin Heidelberg) pp 569–90
- [13] Liang J, Grijalva S and Harley R G 2011 Increased wind revenue and system security by trading wind power in energy and regulation reserve markets *IEEE Trans. Sustain. Energy* **2** 340–7
- [14] Soares T, Pinson P, Jensen T V. and Morais H 2016 Optimal offering strategies for wind power in energy and primary reserve markets *IEEE Trans. Sustain. Energy* **7** 1–10
- [15] Roald L, Misra S, Backhaus S, Chertkov M and Andersson G 2016 Optimal power flow with wind power control and limited expected risk of overloads *19th Power systems computation Conf.* (Genoa) pp 1–7
- [16] Krohn S, Morthorst P E and Awerbuch S 2009 The economics of wind energy *EWEA - Eur. Wind Energy Assoc.* 1–155
- [17] Skytte K 1999 The regulating power market on the Nordic Power Exchange Nord Pool: an econometric analysis *Energy Econ.* **21** 295–308
- [18] Conejo A J, Carrión M and Morales J M 2010 *Decision making under uncertainty in electricity markets* ed F S Hillier, C C Price and S F Austin (Springer US)
- [19] Vandezande L, Meeus L, Belmans R, Saguan M and Glachant J-M 2010 Well-functioning balancing markets: A prerequisite for wind power integration *Energy Policy* **38** 3146–54
- [20] Energinet.dk 2008 *Regulation C2 : The balancing market and balance settlement*
- [21] PLMJ 2014 Renewable Energies - 2013 Legislative changes in the sector *Energy Nat. Resour. - PLMJ* **4** 1–4
- [22] Singh S N and Erlich I 2008 Strategies for wind power trading in competitive electricity markets *IEEE Trans. Energy Convers.* **23** 249–56
- [23] MIBEL 2009 *Description of the operation of the MIBEL*
- [24] Wang Y, Bayem H, Giralt-Devant M, Silva V, Guillaud X and Francois B 2015 Methods for assessing available wind primary power reserve *IEEE Trans. Sustain. Energy* **6** 272–80
- [25] Energinet.dk 2015 *Technical regulation 3.2.5 for wind power plants with a power output above 11 kW*
- [26] EirGrid 2015 *EirGrid Grid Code, version 6*
- [27] Rosenthal R 2008 *GAMS – a user’s guide* (Washington, DC: GAMS Development Corporation)
- [28] Drud A 1996 *CONOPT: a system for large scale nonlinear optimization*
- [29] Bukhsh W A, Zhang C and Pinson P Data for stochastic multiperiod opf problems <https://sites.google.com/site/datasmopf/>



APPENDIX **E**

# Paper E

---

**Title:**

Active distribution grid management based on robust AC optimal power flow

**Authors:**

Tiago Soares, Ricardo Bessa, Pierre Pinson and Hugo Morais

**Published in:**

IEEE Transactions on Smart Grid (under review).

# Active Distribution Grid Management based on Robust AC Optimal Power Flow

Tiago Soares, Ricardo Bessa, Pierre Pinson, *Senior Member, IEEE*, Hugo Morais, *Member, IEEE*

**Abstract**—Further integration of distributed renewable energy sources in distribution systems requires a paradigm change in grid management by the distribution system operators (DSO). DSOs are currently moving to an operational planning approach based on activating flexibility from distributed energy resources in day/hour-ahead stages. This paper follows the DSO trends by proposing a methodology for active grid management by which robust optimization is applied to accommodate spatial-temporal uncertainty. The proposed method entails the use of a multi-period AC-OPF, ensuring a reliable solution for the DSO. Wind and PV uncertainty is modeled based on spatial-temporal trajectories, while a convex hull technique to define uncertainty sets for the model is used. A case study based on real generation data allows illustration and discussion of the properties of the model. An important conclusion is that the method allows the DSO to increase system reliability in the real-time operation. However, the computational effort grows with increases in system robustness.

**Index Terms** — Decision-making; uncertainty; distribution system operator; robust optimization; solar power; wind power.

## NOMENCLATURE

The main notation used throughout the paper is stated next for quick reference. Other symbols are defined as required.

### A. Parameters

$\Delta P$	Power deviation of the vertices of the uncertainty set
$B$	Imaginary part in admittance matrix
$Bus$	Number of buses
$C$	Cost
$E_{BatCap}$	Maximum capacity of energy storage systems
$E_{Min}$	Minimum energy in the energy storage system
$G$	Real part in admittance matrix
$N$	Number of unit resources
$T$	Time horizon
$\bar{y}$	Series admittance of line that connects two buses
$\bar{y}_{sh}$	Shunt admittance of line that connects two buses

### B. Variables

$\theta$	Voltage angle
$E_{stored}$	State of charge of the battery
$P$	Active power
$Q$	Reactive power
$r$	Power flexibility used in the real-time stage
$S$	Apparent power
$V$	Voltage magnitude

$\bar{V}$	Voltage in polar form
$V_{sb}$	Voltage at slack bus
$\Delta V$	Voltage level activated by the DSO in the transformer
$X$	Binary variable

### C. Subscripts

$cb$	Index of capacitor bank units
$CB$	Capacitor bank abbreviation
$Ch$	Storage charge process
$Dch$	Storage discharge process
$dg$	Index of distributed generation units
$DG$	Distributed generation abbreviation
$DR$	Demand response abbreviation
$i, j$	Bus index
$l$	Index of load consumers
$L$	Load consumers abbreviation
$lv$	Index of levels (tap changing) for capacitor banks and transformers
$pv$	Index of photovoltaic power units
$PV$	Photovoltaic power abbreviation
$s$	Index of the vertices of the uncertainty set
$st$	Index of energy storage system units
$su$	Index of external supplier units
$SU$	External supplier abbreviation
$t$	Time index
$trf$	Index of transformer units
$TRF$	Transformer abbreviation
$w$	Index of wind power units
$W$	Wind power abbreviation

### D. Superscripts

$act$	Activation cost of resources in real-time stage
$bid_{dw}$	Maximum offer of downward flexibility
$bid_{up}$	Maximum offer of upward flexibility
$cut$	Generation curtailment power for distributed generation
$dw$	Downward flexibility
$op$	Operating point of the power resource
$shed$	Load shedding
$spill$	Spillage of renewable energy
$up$	Upward flexibility

## I. INTRODUCTION

THE continuous integration of distributed energy resources (DER) [1], specially renewable energy resources (RES), at the distribution grid level will lead to the development of new

models and methodologies to deal with the uncertainty of these resources [2]. Hence, traditional methodologies for operation and management of the distribution grid must be replaced by new active management methodologies, by which distribution system operators (DSOs) can contract/control power generation/consumption (flexibility) from DER to solve congestion/voltage problems in the distribution network [3].

An ideal approach would be to accommodate all traditional distribution grid management methods with new proactive management methods adapted to future distributions systems that include DER controllability to help in grid management. For instance, problems concerning network reconfiguration, voltage limit violation and overcurrent during short periods can be added to the proactive management method.

Currently, DSOs in most European countries employ a reactive approach for grid management, imposing limits in terms of DER (mainly RES) integration in MV and LV levels. For instance, a survey applied under an EU project in several European countries showed that very few DSOs use the forecasts for operational purposes, as well as, contracting services to handle network constraints [4]. Furthermore, the degree of coordination between DER and the DSO control centers is very limited or non-existent in almost all countries.

The flexibility potential from DER (including flexible operation/bids from RES) requires a change in the present paradigm. The trend is to implement proactive and preventive grid management functions based on forecasts with the possibility of reserving/controlling DER connected to the distribution grid. The goal of the DSO remains the same, i.e. to ensure that congestion, voltage and energy delivery problems are solved, while maintaining the proper operation of the system with adequate levels of safety, reliability and power quality. Under high RES integration levels, this goal can be met by combining multi-period optimal power flow (OPF) with uncertainty forecasts.

Most of the literature proposals for the distribution grid management problem are based on stochastic methods with relaxation approaches to the OPF. However, DSOs usually operate under the premise of procuring a solution or scenario that ensures proper levels of robustness and reliability in the system. The regulatory framework “induces” risk aversion to both the DSO and TSO.

In this context, several methodologies have emerged for distribution grid management considering RES uncertainty. These methodologies are most often based on stochastic programming and robust optimization [5], [6]. A decentralized stochastic approach to manage a distribution network with PV production is proposed [7]. However, the model only ensures effectiveness under radial networks. In [8], a stochastic method based on chance-constrained optimization for voltage control under PV uncertainty production is proposed, however, the method considers a probabilistic load flow that analyses the injection of PV power in the distribution system. The authors in [9] consider a point-estimate method to deal with wind uncertainty and a probabilistic OPF. However, the output from the stochastic OPF is a distribution of the decision variables. Nevertheless, for a DSO, a more appropriate output

would be a single solution that is robust in all or a pre-defined percentage of the scenarios.

In contrast with the literature, this paper contributes with a new methodology based on a robust optimization for solving technical problems in the distribution network under RES forecast uncertainty, ensuring a single and safe solution that is more reliable than traditional approaches. The model minimizes the operating costs (flexibility activation) of the DSO, without relaxing any network constraints under a set of spatial-temporal trajectories. The methodology is proposed for a paradigm whereby the DSO preventively manages the distribution grid by contracting flexibility from DER in advance based on forecasted information. This is a recent trend in the scientific community [10]–[12]. Thus, the DSO will have more flexibility capacity to use in real-time operation, thereby increasing the safety and reliability of the system. This work has two major contributions to the state of art: (a) integration of spatial-temporal trajectories [13] to model RES, while using convex hull based techniques to model the uncertainty set; (b) active distribution grid management in a multi-period AC OPF, which is able to ensure the most reliable solution for the distribution grid.

The paper is structured as follows. Section II describes the DSO management problem with a perspective on current and future trends. Section III presents the detailed formulation of the robust approach for the DSO problem on energy resources management under uncertainty. Section IV describes our empirical investigation based on a case study with real data. Section V gathers the most important conclusions.

## II. FRAMEWORK FOR DISTRIBUTION GRID MANAGEMENT

### A. Current Management

The mission of a DSO is to ensure the quality and continuity of supply levels imposed by the regulatory framework. In the past, technical problems such as overcurrent and voltage limit violation were mitigated by planning network investments and changing the network configuration to meet the loads. Now, DSOs have additional flexibility in the network that allows them to solve the local technical problems in the operational domain, instead of solving them in a planning phase. The main benefits are investment deferral and reduced curtailment of DER.

In the operating domain, the typical control actions are network reconfiguration, control of capacitor banks and activation, though in a very limited way, of non-firm connection contracts associated with industrial loads and some DER. Information about forecasts and corresponding uncertainty is not embedded in the current grid-management functions.

Nevertheless, the use of DER flexibility to help in the management of technical problems is of most interest to the DSO. The DER flexibility stands for the amount of power provided by the DERs that assist the DSO in grid management. This means that is a kind of ancillary services, but used by the DSO to solve congestion and voltage problems in the distribution system. As proposed in this work, a better use of DER flexibility can delay or even avoid the need for network expansion. That is, the DSO can use power flexibility

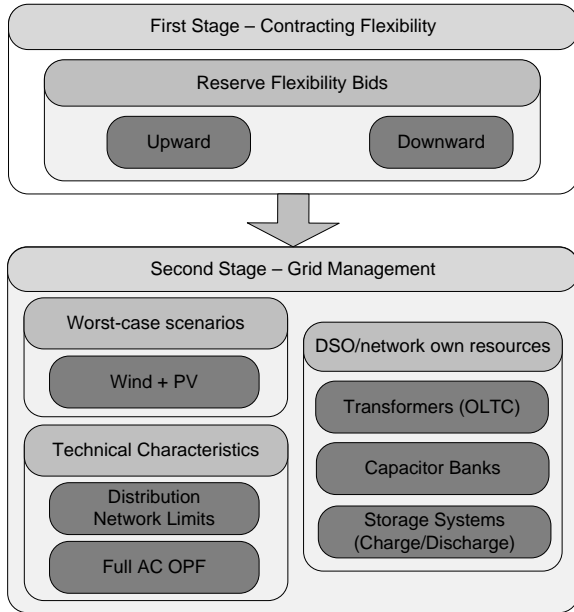

Fig. 1. Diagram of the developed methodology.

provided by DERs to decongest the main power lines/transformers and control the voltage levels in the distribution grid. This gives a certain control freedom to DSO grid management. However, a long-term evaluation is recommended to estimate the savings of the proposed method in the system. Such economic savings must be compared with equivalent costs of network reinforcement to assess the usefulness of the proposed method in long-term.

### B. Future Management

With the continuous introduction of DERs, DSOs have been changing their operation and control paradigms. Thus, fully proactive grid management, by which DERs can be part of the solution for proper operation of the distribution system, is considered. However, RES are part of the problem since they have uncertain generation, thereby increasing the system operation uncertainties. Nevertheless, current developments in wind power technology mean that, to some extent, it is possible to reserve the available wind power to provide power flexibility [14]. In fact, field-tests with the real provision of ancillary services (such as frequency restoration reserves) from renewable power plants performed in Germany [15] and Belgium [16] have demonstrated that it is possible to provide reserve capacity with acceptable accuracy. In this way, future DSO management should integrate new methodologies to deal with RES uncertainty while considering this new capability of RES, as well as considering energy storage systems to help the DSO solve congestion problems and efficiently deliver energy [4].

A new structure for solving technical problems in the distribution grid is illustrated in Fig. 1. The structure is divided into two stages is used: (i) contract of upward and downward flexibility services from DER at day-ahead time-horizon; and (ii) distribution grid management considering the flexibility contracted in the first stage and internal resources of the distribution network, accounting for the worst-case of uncertainty in the system.

The first stage (day-ahead stage) is based on contracting upward and downward flexibility to be used during the real-time stage (second stage) to manage the grid and solve congestion problems, accounting with the uncertainty of renewable sources. In the first stage, upward and downward flexibility bids, respectively given by  $P^{bid\_up}$  and  $P^{bid\_dw}$ , from the DER aggregators are provided to the DSO. The DSO contracts the flexibility to the DER aggregators based on capacity payments. It is noteworthy that wind and PV aggregators should guarantee the provision of the submitted upward and downward flexibility. For instance, by contracting generators or demand response electrically closes to their point of power production. The DER aggregators provide to the DSO the flexibility bids of changing the operating point of their own resources for upward and downward power. The flexibility bids are defined based on the strategy of each aggregator to provide flexibility to the DSO. Wind and PV aggregators can define their bids based on expected profit from supplying this upward and downward flexibility to the DSO, accounting for the costs for changing their operating point [17].

In the real-time stage (second stage), the DSO manages the grid considering the flexibility contracted at day-ahead and the operating point of each DER, as well as its own internal flexibility under the limitations of the technical characteristics of the grid. We understand DSO internal flexibility as the use of static equipment, such as transformers with on-load tap-changing (OLTC) ability, capacitor banks and storage systems. Storage systems owned or managed by the DSO help in the system management, providing additional multi-period flexibility and avoiding constrained situations. Additionally, the storage system contributes to face with high uncertainty production in the distribution system.

Nevertheless, the DSO may contract all the flexibility needed to cover foreseen distribution network problems, considering RES uncertainty and accounting for the economic efficiency of the process. That is the flexibility contracted should be optimized at least cost. Moreover, the core of the methodology lies on the use of a two-stage robust optimization approach to accommodate RES uncertainty, while providing solutions with high reliability levels.

## III. METHODOLOGY

The methodology is based on robust optimization to model RES uncertainty and solve the DSO management problem.

### A. Uncertainty Set Definition

Robust optimization requires the definition of uncertainty sets, e.g. vertices representative of the worst-case solution, as explained in [18]. Uncertainty sets can take different forms, for instance, constructing the uncertainty set through a polyhedral, ellipsoid or scenario set with spatial-temporal correlation is the most common in literature, among others [19].

In our proposed methodology, construction of the uncertainty set is modeled through a scenario set with spatial-temporal correlation. The methodology entails some assumptions. For simplicity, the uncertainty modeled in the methodology refers only to wind and solar power. Thus, the

load profile for the next 24 hours is assumed to be known. Furthermore, note that spatial-temporal correlation is modeled in scenario generation for wind and solar power independently. This means that uncertain variables for wind and solar power are independent of each other.

The uncertainty sets for wind and PV generation are constructed using a scenario set. The scenario set  $J$  is obtained through the generation of spatial-temporal trajectories (or scenarios). For each period, the deviation between the scenario set and the conditional mean forecast creates a cloud of  $N_J$  points representative of the uncertainty space. Then, the uncertainty set  $\Omega$  is defined as the convex hull of these points constructed through the quickhull algorithm [20]. The vertices  $u$  of the uncertainty set  $\Omega$  that are selected for the optimization process are represented by  $\Delta P_{w(w,t,s)}$  in the full problem formulation. In addition, the number of vertices of the convex hull can increase significantly when considering a large amount of intermittent resources, which can be intractable in the time frame available to the DSO to solve the problem. Thus, algorithms to reduce the number of vertices can be considered. The recursive Douglas-Peucker algorithm [21] is based on polyline simplifications and can reduce the number of vertices that characterize the uncertainty set. An improved and accelerated version of the algorithm [22] can be used to significantly reduce the vertices of the uncertainty set.

### B. General Problem Formulation

The problem relates to minimizing the operating costs of the DSO. A multi-period and multi-stage robust optimization problem is modeled. In the first stage (day-ahead stage), the DSO contracts the flexibility to the DER to be used in the second stage (real-time operation), where the power system is operated under the uncertainty of the renewable energy resources. In the second stage, the DSO manages the distribution system based on the worst-case of the uncertainty. Thus and based on the flexibility contracted at day-ahead, the DSO is prepared to manage the grid under any realization of wind and solar power covered by the uncertainty set. Similar problems are commonly solved in the literature using multi-stage robust optimization techniques [5], [18]. A general form of the robust optimization problem is expressed as

$$\min_x \sum_t C_t^{DA}(x) + \max_u \min_y \sum_t C_t^{RT}(y) \quad (1)$$

$$s.t. A_t^{DA}(x) \leq 0, \quad (2)$$

$$h_t^{RT}(y, u) = 0, \quad (3)$$

$$g_t^{RT}(y, u) \leq 0, \quad (4)$$

where the vector  $x$  includes the day-ahead decision vectors for contracting flexibility, while real-time adjustments with respect to the contracted flexibility are included in the vector of recourse variables  $y$ , accounting for the vertices  $u$  of the uncertainty set  $\Omega$ , i.e.  $u \in \Omega$ .  $C_t^{DA}(x)$  stands for the cost function of contracting flexibility in day-ahead that composes the objective function of the first-stage. On the other hand,  $C_t^{RT}(y)$  is the cost function of operating the distribution system in real-time that composes the recourse function. All the constraints involving only first-stage variables are modeled in

the form of (2). In contrast, constraints including recourse variables are divided into equalities (3) and inequalities (4).

### C. Full Mathematical Formulation

This section starts by presenting and explaining the full objective function and respective constraints of the first-stage problem, followed by the full objective function and constraints relating to the recourse stage. It is noteworthy that the problem is modeled as a mixed-integer nonlinear optimization problem, by comprising a full AC OPF model.

The first-stage decisions comprise the flexibility contracted by the DSO in the day-ahead market, where the objective function  $C_t^{DA}(x)$  is modeled as

$$\begin{aligned} & \sum_{dg=1}^{N_{DG}} \left( C_{DG(dg,t)}^{up} P_{DG(dg,t)}^{up} + C_{DG(dg,t)}^{dw} P_{DG(dg,t)}^{dw} \right) + \\ & \sum_{w=1}^{N_W} \left( C_{W(w,t)}^{up} P_{W(w,t)}^{up} + C_{W(w,t)}^{dw} P_{W(w,t)}^{dw} \right) + \\ & \sum_{pv=1}^{N_{PV}} \left( C_{PV(pv,t)}^{up} P_{PV(pv,t)}^{up} + C_{PV(pv,t)}^{dw} P_{PV(pv,t)}^{dw} \right) + \\ & \sum_{l=1}^{N_L} \left( C_{DR(l,t)}^{up} P_{DR(l,t)}^{up} + C_{DR(l,t)}^{dw} P_{DR(l,t)}^{dw} \right) \quad \forall t \in \{1, \dots, T\}, \end{aligned} \quad (1a)$$

The decision variable vector  $x$  considers the first-stage variables

$$x = \{ P_{DG}^{up}, P_{DG}^{dw}, P_W^{up}, P_W^{dw}, P_{PV}^{up}, P_{PV}^{dw}, P_{DR}^{up}, P_{DR}^{dw} \},$$

The first-stage constraints considering the upper bound of upward and downward flexibility offers for DG units (2a) and (2b), respectively, are given by

$$P_{DG(dg,t)}^{up} \leq P_{DG(dg,t)}^{bid\_up} \quad \forall t \in \{1, \dots, T\}, \forall dg \in \{1, \dots, N_{DG}\}, \quad (2a)$$

$$P_{DG(dg,t)}^{dw} \leq P_{DG(dg,t)}^{bid\_dw} \quad \forall t \in \{1, \dots, T\}, \forall dg \in \{1, \dots, N_{DG}\}, \quad (2b)$$

In addition, wind and PV aggregators are modeled with the ability of upward and downward flexibility, i.e. it is assumed that wind power producers can provide some flexibility [14]. The wind power for downward flexibility is constrained by the operating point of the wind power aggregator  $P_{W(w,t)}^{op}$ , as in (2c), while the wind power for upward flexibility is constrained by the wind bid for reserving power, as in (2d).

$$P_{W(w,t)}^{dw} \leq P_{W(w,t)}^{op} \quad \forall t \in \{1, \dots, T\}, \forall w \in \{1, \dots, N_W\}, \quad (2c)$$

$$P_{W(w,t)}^{up} \leq P_{W(w,t)}^{bid\_up} \quad \forall t \in \{1, \dots, T\}, \forall w \in \{1, \dots, N_W\}, \quad (2d)$$

These constraints are also applied to the PV aggregators. Similarly, the upper and lower bounds for the DR aggregators are given by

$$P_{DR(l,t)}^{up} \leq P_{DR(l,t)}^{bid\_up} \quad \forall t \in \{1, \dots, T\}, \forall l \in \{1, \dots, N_L\}, \quad (2e)$$

$$P_{DR(l,t)}^{dw} \leq P_{DR(l,t)}^{bid\_dw} \quad \forall t \in \{1, \dots, T\}, \forall l \in \{1, \dots, N_L\}, \quad (2f)$$

where  $P_{DR(l,t)}^{bid\_up}$  is the maximum amount of load that can be reduced (offer).

The objective function and constraints related to the recourse stage are then described. Following adaptive robust theory, the inner max min problem given by  $C_t^{RT}(y)$  can be replaced by an auxiliary variable  $\beta$  representing the worst-case recourse.

In parallel, looking at equalities constraints from the recourse function (related to  $h_t^{RT}(y, u)$  in equation (3)), the

decision variable vector  $y$  contains

$$y = \left\{ \begin{array}{l} r_{DG}^{up}, r_{DG}^{dw}, P_{DG}^{cut}, r_W^{up}, r_W^{dw}, \Delta P_W, P_W^{spill}, r_{PV}^{up}, r_{PV}^{dw}, \Delta P_{PV}, P_{PV}^{spill}, r_{DR}^{up}, r_{DR}^{dw}, \\ P_L^{shed}, P_{Dch}, P_{Ch}, Q_{DG}, Q_L, Q_{CB}, E_{stored}, X_{CB}, X_{TRF}, V_i, V_{sb}, \Delta V_{TRF}, \theta_{ij} \end{array} \right\},$$

including active and reactive power balance, reactive power consumption, capacitor banks tap-changing, transformers with on-load tap-changing, and energy storage balance. Thus, the active power balance in each bus yields,

$$\begin{aligned} & \sum_{dg=1}^{N_{DG}} \left( P_{DG(dg,t,s)}^{op,i} + r_{DG(dg,t,s)}^{up,i} - r_{DG(dg,t,s)}^{dw,i} - P_{DG(dg,t,s)}^{cut} \right) + \\ & \sum_{su=1}^{N_{SU}} P_{SU(su,t,s)}^i + \sum_{st=1}^{N_{ST}} \left( P_{Dch(st,t,s)}^i - P_{Ch(st,t,s)}^i \right) + \\ & \sum_{w=1}^{N_W} \left( P_{W(w,t,s)}^{op,i} + \Delta P_{W(w,t,s)}^i + r_{W(w,t,s)}^{up,i} - r_{W(w,t,s)}^{dw,i} - P_{W(w,t,s)}^{spill,i} \right) + \\ & \sum_{pv=1}^{N_{PV}} \left( P_{PV(pv,t,s)}^{op,i} + \Delta P_{PV(pv,t,s)}^i + r_{PV(pv,t,s)}^{up,i} - r_{PV(pv,t,s)}^{dw,i} - P_{PV(pv,t,s)}^{spill,i} \right) + \\ & \sum_{l=1}^{N_L} \left( P_{DR(l,t,s)}^{op,i} + r_{DR(l,t,s)}^{up,i} - r_{DR(l,t,s)}^{dw,i} + P_{L(l,t,s)}^{shed,i} - P_{L(l,t,s)}^i \right) = \\ & G_{ii} V_{i(t,s)}^2 + V_{i(t,s)} \sum_{j \in TL} V_{j(t,s)} \left( G_{ij} \cos \theta_{ij(t,s)} + B_{ij} \sin \theta_{ij(t,s)} \right) \end{aligned} \quad (3a)$$

$$\forall t \in \{1, \dots, T\}, \forall i \in \{1, \dots, N_{Bus}\}, \forall s \in \{1, \dots, N_S\}, \theta_{ij(t,s)} = \theta_{i(t,s)} - \theta_{j(t,s)}$$

where  $P_{W(w,t)}^{op}$  is the conditional mean forecast of wind producer scheduled at day-ahead market and  $\Delta P_{W(w,t,s)}$  is the deviation of wind power production in the vertices from the conditional mean forecast that models the uncertainty set.  $P_{SU(su,t,s)}$  is the energy provided by external suppliers to the distribution system through upstream connections, i.e. the energy that comes from the transmission system to supply the consumption of the distribution network. In parallel, it is assumed that the reactive power balance only considers reactive power provided by DG (CHP) units, external suppliers and capacitor banks, formulated as

$$\begin{aligned} & \sum_{dg=1}^{N_{DG}} \left( Q_{DG(dg,t,s)}^i \right) - \sum_{l=1}^{N_L} Q_{L(l,t,s)}^i + \sum_{su=1}^{N_{SU}} Q_{SU(su,t,s)}^i + \sum_{cb=1}^{N_{CB}} \sum_{lv=1}^{N_{levels}} Q_{CB(cb,t,s,lv)}^i = \\ & V_{i(t,s)} \sum_{j \in TL} V_{j(t,s)} \left( G_{ij} \sin \theta_{ij(t,s)} + B_{ij} \cos \theta_{ij(t,s)} \right) - B_{ii} V_{i(t,s)}^2 \end{aligned} \quad (3b)$$

$$\forall t \in \{1, \dots, T\}, \forall i \in \{1, \dots, N_{Bus}\}, \forall s \in \{1, \dots, N_S\}, \theta_{ij(t,s)} = \theta_{i(t,s)} - \theta_{j(t,s)}$$

where the reactive power production for DG (CHP) units takes into account the active power production from the day-ahead market, as well as the upward and downward active power flexibility scheduled by the DSO with a fixed  $\tan \Phi = 0.3$  [23].

$$\begin{aligned} & Q_{DG(dg,t,s)} = \left( P_{DG(dg,t,s)}^{op,i} + r_{DG(dg,t,s)}^{up,i} - r_{DG(dg,t,s)}^{dw,i} - P_{DG(dg,t,s)}^{cut} \right) \tan \Phi \\ & \forall t \in \{1, \dots, T\}, \forall dg \in \{1, \dots, N_{DG}\}, \forall s \in \{1, \dots, N_S\} \end{aligned} \quad (3c)$$

Furthermore, the reactive power consumption in the system is modeled based on the relation between the total active power consumption and  $\tan \Phi$  for each load  $l$ .  $\tan \Phi$  for each load  $l$  is usually assumed as 0.3 [24].

$$\begin{aligned} & Q_{L(l,t,s)} = \left( P_{L(l,t,s)} - P_{DR(l,t,s)}^{op} + r_{DR(l,t,s)}^{dw} - r_{DR(l,t,s)}^{up} - P_{L(l,t,s)}^{shed} \right) \tan \Phi \\ & \forall t \in \{1, \dots, T\}, \forall l \in \{1, \dots, N_L\}, \forall s \in \{1, \dots, N_S\} \end{aligned} \quad (3d)$$

Furthermore, the reactive power consumption is partly provided by generators and static equipment in the network.

Capacitor banks are used to provide reactive power to the transformer, located at the substation. It is assumed that this equipment is owned by the DSO. Traditionally, capacitor banks have levels of reactive power production, and can be modeled as

$$\begin{aligned} & Q_{CB(cb,t,s,lv)} = Q_{CB(cb,t,lv)}^{levels} X_{CB(cb,t,s,lv)} \\ & \forall t \in \{1, \dots, T\}, \forall cb \in \{1, \dots, N_{CB}\}, \forall s \in \{1, \dots, N_S\}, \forall lv \in \{1, \dots, N_{levels}\} \end{aligned} \quad (3e)$$

$$\begin{aligned} & \sum_{lv=1}^{N_{levels}} X_{CB(cb,t,s,lv)} = 1 \\ & \forall t \in \{1, \dots, T\}, \forall cb \in \{1, \dots, N_{CB}\}, \forall s \in \{1, \dots, N_S\} \end{aligned} \quad (3f)$$

In addition, transformers with OLTC ability are used to ensure voltage control in the substation. It is assumed that the transformers are owned by the DSO. Thus, the voltage impact of each tap-changing level in the secondary bus of the transformer is known. The tap-changing constraints can be modeled as

$$\begin{aligned} & \Delta V_{TRF(trf,t,s,lv)} = V_{TRF(trf,t,lv)}^{levels} X_{TRF(trf,t,s,lv)} \\ & \forall t \in \{1, \dots, T\}, \forall s \in \{1, \dots, N_S\}, \forall trf \in \{1, \dots, N_{TRF}\}, \forall lv \in \{1, \dots, N_{levels}\} \end{aligned} \quad (3g)$$

$$\begin{aligned} & \sum_{lv=1}^{N_{levels}} X_{TRF(trf,t,s,lv)} = 1 \\ & \forall t \in \{1, \dots, T\}, \forall s \in \{1, \dots, N_S\}, \forall trf \in \{1, \dots, N_{TRF}\} \end{aligned} \quad (3h)$$

$$\forall t \in \{1, \dots, T\}, \forall s \in \{1, \dots, N_S\}, \forall trf \in \{1, \dots, N_{TRF}\}$$

$$V_{sb(t,s)} = V_{sb(t,s)}^{ref} + \sum_{lv=1}^{N_{levels}} \Delta V_{TRF(trf,t,s,lv)} \quad (3i)$$

$$\forall t \in \{1, \dots, T\}, \forall s \in \{1, \dots, N_S\}, \forall trf \in \{1, \dots, N_{TRF}\}$$

where  $\Delta V_{TRF(trf,t,s,lv)}$  is the voltage level that will be activated by the DSO in the transformer unit at slack bus. In parallel,  $V_{TRF(trf,t,lv)}^{levels}$  depicts all the possible levels available on the OLTC ability of the transformer. Finally,  $X_{TRF(trf,t,s,lv)}$  is a binary decision variable which defines the activation of the chosen level. Moreover, the battery balance of storage units follows

$$E_{stored(st,t,s)} = E_{stored(st,t-1,s)} + \eta_{Ch(st)} P_{Ch(st,t,s)} - \frac{1}{\eta_{Dch(st)}} P_{Dch(st,t,s)} \quad (3j)$$

$$\forall t \in \{1, \dots, T\}, \forall st \in \{1, \dots, N_{ST}\}, \forall s \in \{1, \dots, N_S\}$$

where energy from previous period, and charge and discharge ability are considered.

In parallel, inequalities constraints (related to  $g_t^{RT}(y,u)$  in (4)), the decision variable vector  $y$  contains

$$y = \left\{ \begin{array}{l} r_{DG}^{up}, r_{DG}^{dw}, P_{DG}^{cut}, r_W^{up}, r_W^{dw}, \Delta P_W, r_{PV}^{up}, r_{PV}^{down}, \Delta P_{PV}, r_{DR}^{up}, \\ r_{DR}^{down}, P_L^{shed}, P_{Dch}, P_{Ch}, E_{stored}, X_{Dch}, X_{Ch}, V_i, \theta_{ij}, \beta \end{array} \right\},$$

and include operating costs for balancing the system, upper and lower bounds of active and reactive power to the upward and downward flexibility of all energy resources, as well as non-simultaneity of storage devices, transformers and lines capacity, upper and lower bounds of voltage angles and magnitude, and declaration of non-negative variables.

Thus, the inequality constraint for the operating costs for upward and downward flexibility of different aggregators is considered (4a). Aggregators with distributed generation, wind and PV related with uncertainty and DR are modeled as external entities that provide flexibility and information about their resources' electrical location to the DSO. On the other

hand, it is assumed that storage units, capacitor banks and transformers with OLTC ability are owned by the DSO, and therefore these resources are modeled to balance the distribution system, with

$$\begin{aligned}
\beta_t \geq & \sum_{dg=1}^{N_{DG}} \left[ C_{DG(dg,t)}^{act} \left( r_{DG(dg,t,s)}^{up} - r_{DG(dg,t,s)}^{dw} \right) + C_{DG(dg,t)}^{cut} P_{DG(dg,t,s)}^{cut} \right] + \\
& \sum_{w=1}^{N_W} \left[ C_{W(w,t)}^{act} \left( r_{W(w,t,s)}^{up} - r_{W(w,t,s)}^{dw} \right) + C_{W(w,t)}^{spill} P_{W(w,t,s)}^{spill} \right] + \\
& \sum_{pv=1}^{N_{PV}} \left[ C_{PV(pv,t)}^{act} \left( r_{PV(pv,t,s)}^{up} - r_{PV(pv,t,s)}^{dw} \right) + C_{PV(pv,t)}^{spill} P_{PV(pv,t,s)}^{spill} \right] + \\
& \sum_{l=1}^{N_L} \left[ C_{DR(l,t)}^{act} \left( r_{DR(l,t,s)}^{up} - r_{DR(l,t,s)}^{dw} \right) + C_{L(l,t,s)}^{shed} P_{L(l,t,s)}^{shed} \right] + \\
& \sum_{st=1}^{N_{ST}} \left( C_{Dch(st,t)} P_{Dch(st,t,s)} - C_{Ch(st,t)} P_{Ch(st,t,s)} \right) + \\
& \sum_{cb=1}^{N_{CB}} \sum_{lv=1}^{N_{levels}} C_{CB(cb,t)} \left| X_{CB(cb,t-1,s,lv)} - X_{CB(cb,t,s,lv)} \right| + \\
& \sum_{trf=1}^{N_{TRF}} \sum_{lv=1}^{N_{levels}} C_{TRF(trf,t)} \left| X_{TRF(trf,t-1,s,lv)} - X_{TRF(trf,t,s,lv)} \right| \\
& \forall t \in \{1, \dots, T\}, \forall s \in \{1, \dots, N_S\}
\end{aligned} \tag{4a}$$

where the upper and lower bounds of the activation of active power for DG units considering the upward and downward flexibility are given by (4b) and (4c), respectively, while the generation curtailment power is expressed in (4d), where  $P_{DG(dg,t)}^{op}$  is the operating point of the DG units. This gives

$$r_{DG(dg,t,s)}^{up} \leq P_{DG(dg,t)}^{up} \quad \forall t \in \{1, \dots, T\}, \forall dg \in \{1, \dots, N_{DG}\}, \forall s \in \{1, \dots, N_S\} \tag{4b}$$

$$r_{DG(dg,t,s)}^{dw} \leq P_{DG(dg,t)}^{dw} \quad \forall t \in \{1, \dots, T\}, \forall dg \in \{1, \dots, N_{DG}\}, \forall s \in \{1, \dots, N_S\} \tag{4c}$$

$$\begin{aligned}
P_{DG(dg,t,s)}^{cut} & \leq P_{DG(dg,t)}^{op} - r_{DG(dg,t,s)}^{dw} \\
\forall t \in \{1, \dots, T\}, \forall dg \in \{1, \dots, N_{DG}\}, \forall s \in \{1, \dots, N_S\}
\end{aligned} \tag{4d}$$

In addition, wind and PV aggregators are modeled with the ability of upward and downward flexibility. The wind power for activating upward flexibility is constrained by the wind contracted in the first-stage decision for reserve power, as in (4e), while the wind power for activating downward flexibility is constrained by the downward flexibility contracted in the first-stage decision, as in (4f). When the downward flexibility is insufficient to meet the DSO requirement, wind spillage can be used, being constrained by (4g).

$$r_{W(w,t,s)}^{up} \leq P_{W(w,t)}^{up} \quad \forall t \in \{1, \dots, T\}, \forall w \in \{1, \dots, N_W\}, \forall s \in \{1, \dots, N_S\} \tag{4e}$$

$$r_{W(w,t,s)}^{dw} \leq P_{W(w,t)}^{dw} \quad \forall t \in \{1, \dots, T\}, \forall w \in \{1, \dots, N_W\}, \forall s \in \{1, \dots, N_S\} \tag{4f}$$

$$\begin{aligned}
P_{W(w,t,s)}^{spill} & \leq P_{W(w,t)}^{op} - r_{W(w,t,s)}^{dw} + \Delta P_{W(w,t,s)} \\
\forall t \in \{1, \dots, T\}, \forall w \in \{1, \dots, N_W\}, \forall s \in \{1, \dots, N_S\}
\end{aligned} \tag{4g}$$

These constraints are also applied to the PV aggregators. In parallel, the upper and lower bounds for the activation of DR aggregators are given by

$$r_{DR(l,t,s)}^{up} \leq P_{DR(l,t)}^{up} \quad \forall t \in \{1, \dots, T\}, \forall l \in \{1, \dots, N_L\}, \forall s \in \{1, \dots, N_S\} \tag{4h}$$

$$r_{DR(l,t,s)}^{dw} \leq P_{DR(l,t)}^{dw} \quad \forall t \in \{1, \dots, T\}, \forall l \in \{1, \dots, N_L\}, \forall s \in \{1, \dots, N_S\} \tag{4i}$$

$$P_{DR(l,t,s)}^{shed} \leq P_{L(l,t)} \quad \forall t \in \{1, \dots, T\}, \forall l \in \{1, \dots, N_L\}, \forall s \in \{1, \dots, N_S\} \tag{4j}$$

where the load shedding is limited by the load in the system.

Storage technical limits in each period  $t$  combine distinct inequalities constraints. Thus, the storage devices are used to reduce congestion when needed. Furthermore, the cost of using charge and discharge ability is modeled in eq. (4a). It is assumed that the costs for charge and discharge already consider the battery degradation over time [25]. Upper and lower bounds for energy stored in the battery, as well as the charge and discharge limit per storage unit are modeled as

$$E_{Min(st,t)} \leq E_{stored(st,t,s)} \leq E_{BatCap(st,t)} \tag{4k}$$

$$P_{Ch(st,t,s)} \leq P_{Ch(st,t)}^{Max} X_{Ch(st,t)} \tag{4l}$$

$$P_{Dch(st,t,s)} \leq P_{Dch(st,t)}^{Max} X_{Dch(st,t)} \tag{4m}$$

$$X_{Ch(st,t)} + X_{Dch(st,t)} \leq 1 \tag{4n}$$

$$\forall t \in \{1, \dots, T\}, \forall st \in \{1, \dots, N_{ST}\}, \forall s \in \{1, \dots, N_S\}$$

where the charge and discharge ability of each storage unit cannot occur at the same time, as in (4n). Furthermore, the energy flow from upstream networks is limited through transformers that adapt the voltage level from high voltage to medium voltage. Therefore, the external supplier provides energy to the DSO through these transformers, which results in a constraint considering the upper limit of the transformers, such that

$$\left( \sum_{su=1}^{N_{SU}} P_{SU(su,t,s)}^i \right)^2 + \left( \sum_{su=1}^{N_{SU}} Q_{SU(su,t,s)}^i \right)^2 \leq \left( S_{trf}^{Max} \right)^2, \forall t \in \{1, \dots, T\}, \tag{4o}$$

$$\forall i \in \{1, \dots, N_{Bus}\}, \forall s \in \{1, \dots, N_S\}, \forall trf \in \{1, \dots, N_{TRF}\}$$

Similarly, the thermal limit of distribution lines constrains the power flowing from bus  $i$  to bus  $j$ , and vice-versa, such as

$$\left| \overline{V_{i(t,s)}} \left[ y_{ij} \overline{V_{j(t,s)}} + y_{sh(i)} \overline{V_{i(t,s)}} \right] \right| \leq S_{TL}^{Max}, \quad \overline{V_{j(t,s)}} = \overline{V_{i(t,s)}} - \overline{V_{j(t,s)}} \tag{4p}$$

$$\left| \overline{V_{j(t,s)}} \left[ y_{ij} \overline{V_{j(t,s)}} + y_{sh(j)} \overline{V_{j(t,s)}} \right] \right| \leq S_{TL}^{Max}, \quad \overline{V_{j(t,s)}} = \overline{V_{j(t,s)}} - \overline{V_{i(t,s)}} \tag{4q}$$

$$\forall t \in \{1, \dots, T\}, \forall i, j \in \{1, \dots, N_{Bus}\}, \forall s \in \{1, \dots, N_S\}, i \neq j$$

where the bus voltage magnitude limits are represented by

$$V_{Min}^i \leq V_{i(t,s)} \leq V_{Max}^i, \quad \forall t \in \{1, \dots, T\}, \forall s \in \{1, \dots, N_S\} \tag{4r}$$

assuming that the voltage magnitude is fixed and defined by the DSO for the slack bus (upstream bus connection).

#### IV. EVALUATION OF DISTRIBUTION GRID MANAGEMENT

This section presents a case study that illustrates the application of the proposed models and their respective performance. The presented case study has been chosen to cover a diversity of uncertain situations, allowing demonstration of the proposed model. The simulation was performed with MATLAB and GAMS.

##### A. Outline

The case study is partially based on the case study presented in [26]. The original distribution network is presented in [27], while the energy mix in 2050 used for updating the network is proposed in [28]. Fig. 2 shows an 11 kV distribution network with 37 buses ( $N_{Bus}=37$ ), connected to the high voltage network through two power transformers of 10 MVA each. For simplicity in the analysis of the case study, the DERs are aggregated by technology, so one aggregator represents a specific type of DER technology. However, note

TABLE I: CONSUMERS CHARACTERISTICS.

Load	Bus	Active power consumption (kW)		
		Max	Mean	Min
1	3	1190.5	734.7	429.9
2	4	1015.6	644.5	237.0
3	6	1184.2	662.8	101.7
4	7	1259.1	777.0	453.9
5	9	1252.4	845.5	619.9
6	10	1040.9	693.3	343.5
7	12	1030.1	635.7	371.4
8	14	19074	1210.3	445.1
9	16	2598.3	1730.6	857.5
10	18	1184.2	799.5	586.1
11	20	1184.2	662.8	101.7
12	21	1190.5	734.7	429.9
13	23	1272.3	847.4	419.9
14	24	1252.4	845.5	619.9
15	26	1030.1	635.7	371.4
16	28	878.8	557.6	205.0
17	29	996.1	557.5	85.5
18	31	1001.4	618.0	361.0
19	32	1011.9	674.0	333.9
20	34	1252.4	701.0	107.5
21	36	1074.1	681.6	250.6
22	37	1030.1	635.7	371.4

TABLE II: TRANSFORMER AND CAPACITOR BANK CHARACTERISTICS.

Equipment	Number of units	Tap-changing	Tap-changing capacity	Cost (m.u. per change)
Transformer	2	21	0.1 p.u.	0.19
Capacitor Bank	1	5	0.2 Mvar	0.47

TABLE III: ENERGY STORAGE SYSTEM CHARACTERISTICS.

Equipment	Number of units	Charge rate (kW)	Discharge rate (kW)	Capacity (kWh)	Charge cost (m.u./kWh)	Discharge cost (m.u./kWh)
ESS	4	150	200	250	0.030	0.065

TABLE IV: GENERAL CHARACTERISTICS AND OPERATING POINT FOR DER.

DER	Number of units	Total installed power	Operating point (MW)		
			Max	Mean	Min
CHP	3	2.5 (Mva)	1.5	1.15	1
External supplier	1	20 (Mva)	-	-	-
PV	22	7.74 (MWp)	5.55	1.96	0
Wind	2	2.5 (MW)	1.88	1.77	1.52
DR	22	4.65 (MW)	0.1	0.03	0

TABLE V: DER UPWARD AND DOWNWARD FLEXIBILITY AND COSTS.

DER	Upward cost (m.u./kWh)			Downward cost (m.u./kWh)		
	Max	Mean	Min	Max	Mean	Min
CHP	0.15	0.10	0.05	0.09	0.06	0.03
PV	-	0.11	-	-	0.06	-
Wind	-	0.10	-	-	0.05	-
DR	-	0.22	-	-	0.17	-

TABLE VI: DER ACTIVATION AND CURTAILMENT COSTS.

DER	Activation cost(m.u./kWh)	Curtailement / spillage / load shedding (m.u./kWh)
CHP	0.18	0.36
PV	0.13	0.30
Wind	0.12	0.30
DR – load	0.26	0.90

that the model has been designed to deal with aggregators with a mixed portfolio. In each consumption point ( $N_L=22$ ), the aggregation of the available DR is also considered. The distribution network supplies energy to 1908 consumers (1850 domestic consumers, 2 industries, 50 commercial stores, and 6

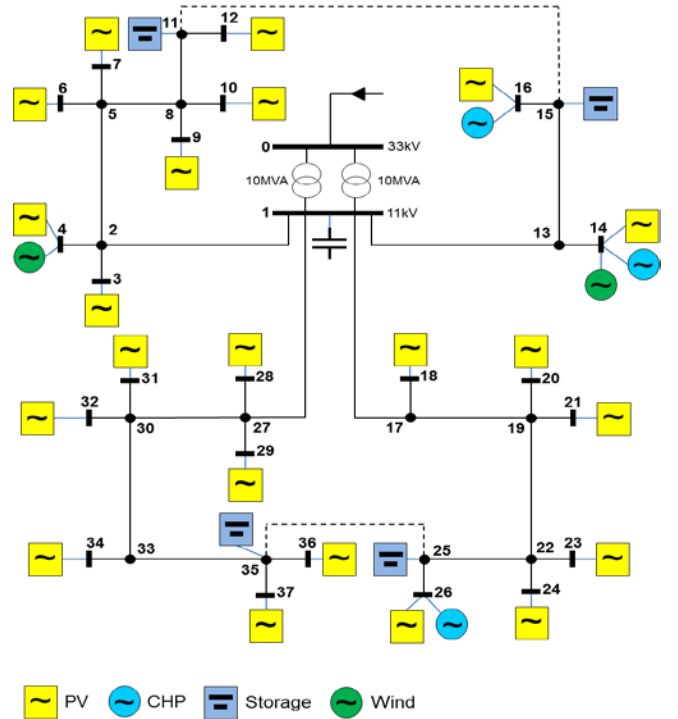

Fig. 2. 37-Bus distribution network (adapted from [27]).

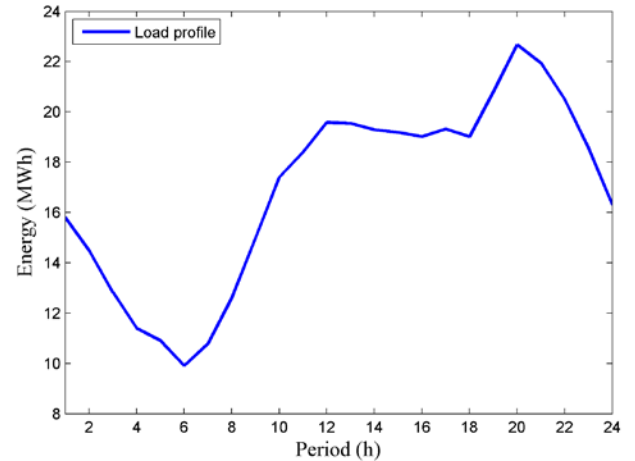

Fig. 3. Profile of the total power consumption in the distribution grid.

service buildings) [27]. The consumption characteristics in each consumption bus, as well as the consumption profiles of each type of consumer are the same as those used in [26]. Table I summarizes the consumption in each bus. The total load consumption in each period for the distribution network is shown in Fig. 3.

### 1) DSO Internal Resources

The DSO is the owner of some equipment installed in the network that supports grid management. Thus transformers with OLTC, capacitor banks and energy storage systems are considered. The general characteristics of the transformers and capacitor bank are shown in Table II. The on-load tap-changer of the transformers can lead to a maximum deviation in the voltage level of 0.1 p.u. A cost for using tap-changing ability based on [29] is considered, since its use reduces the lifetime and increases the maintenance of the equipment. The capacitor bank tap-changing of reactive power production can reach a



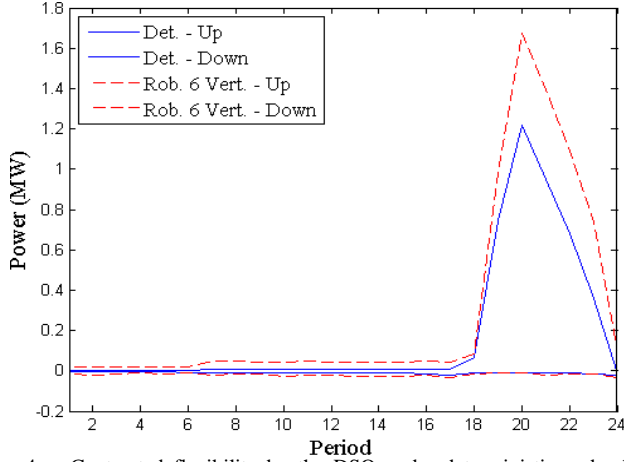

Fig. 4. Contracted flexibility by the DSO under deterministic and robust approach with 6 vertices.

TABLE VII: DAY-AHEAD TOTAL OPERATIONS COSTS, FLEXIBILITY AND LOAD SHEDDING FOR A 24-HOUR PERIOD SIMULATION.

Model	Deterministic	Robust 3 vert.	Robust 4 vert.	Robust 6 vert.
DG flex (MW)	1.195	1.298	1.325	1.375
DR flex (MW)	2.633	3.645	3.814	4.108
Storage (MW)	0.511	0.450	0.455	0.461
Load shedding (MW)	0	0	0	0
Flex cost (m.u.)	23.722	23.95	24.01	24.063
Operating cost (m.u.)	23.722	23.95	24.01	24.063

TABLE VIII: TOTAL EXPECTED OPERATIONS COSTS; FLEXIBILITY AND LOAD SHEDDING OF 24 HOUR PERIOD SIMULATION AFTER THE VALIDATION PROCESS.

Model	Deterministic	Robust 3 vert.	Robust 4 vert.	Robust 6 vert.
DG flex (MW)	1.192	1.229	1.250	1.314
DR flex (MW)	2.923	3.112	3.168	3.215
Storage (MW)	0.116	0.167	0.237	0.270
Load shedding (MW)	0.698	0.421	0.273	0.130
Flex cost (m.u.)	23.718	23.859	23.928	23.969
Operating costs (m.u.)	24.413	24.234	24.155	24.053

maximum reactive power of 0.8 Mvar. As for the transformers, the capacity bank lifetime reduces with the number of changes of the tap position. The cost for tap-changing is based on the formula for capacity bank tap-changing [29]. Throughout the network, energy storage systems with charging and discharging ability are installed. All the ESS equipment has the same characteristics, shown in Table III. It is noteworthy that the discharge price incorporates a degradation cost of 0.03 m.u./kWh, based on the study in [25].

## 2) DER in the Network

The distribution network considers different aggregators of DER, each representing a different DER. Table IV provides general information on the DER. In addition, the operating point of the DER is given by a previous dispatch from the market.

All DERs are able to provide flexibility based on their generation level. Table V shows the costs of upward and downward flexibility of the different aggregators. The upward and downward flexibility of CHP, external suppliers and DR go from its level of operating point to its maximum and minimum level of output power, respectively. In addition, it is

assumed in the validation stage (real-time simulation with measured data) of the robust solution that the upward and downward flexibility costs increases by 20% when procured during the validation stage. That is, it is assumed that the real-time activation of these resources is more expensive. The costs for real-time activation, CHP curtailment, renewable spillage and load shedding are shown in Table VI.

The PV and wind power from aggregators are modeled as random variables. Upward and downward flexibility is used according the bids that these aggregators submit to the DSO. The downward flexibility bid is equal to the energy operating point of these aggregators, previously scheduled in the market. The scenarios for wind power generation over the 24-hour periods can be found in [30], [31]. The offering bids were determined for a 24-hour period based on [17]. The use of the constant strategy has been assumed. The constant strategy splits part of the available wind power for energy and upward flexibility [17]. For PV aggregators, a scenario generation based on probability forecasts for short-term production has been performed. The probabilistic forecast was based on the quantile forecast from [32]. These quantiles were used to generate the scenarios and bids. The scenario generation process described in [33] has been used to generate the spatial-temporal trajectories or scenarios. The bids were performed based on the constant approach shown in [17].

A different number of vertices of the uncertainty set ( $N_s$ ) have been used in this study for comparison of the performance of the methodology, i.e. robust approach with 3, 4 and 6 vertices has been selected.

## B. Results

### 1) Day-ahead Solution

A number of simulations for the robust approach considering a different number of vertices have been performed. The number of vertices collected for building the uncertainty set was based on the efficiency of the methodology in terms of computational performance and solution quality. In contrast, the deterministic simulation is based on the deterministic version of the proposed robust model, where the conditional mean forecast of wind and PV is used as the expected power generation for these resources.

The total operating costs for 24-hour period simulation considering a comparison between the deterministic and robust approach are shown in Table VII. It can be concluded that increasing the number of vertices of the robust optimization approach will generate a more robust solution to the system, which results in a higher cost to the DSO. The high cost of the robust model with 6 vertices is due to reserving more flexibility in the system for some periods.

Fig. 4 presents an hourly comparison of the contracted flexibility for upward and downward for all resources (wind, PV, CHP and DR). In general, robust approach reserves a higher level of upward and downward flexibility, since the solution is based on the worst-case solution. Periods 18 to 23 present higher contracted flexibility, since congestion situations are expected in the power transformer and in the network branches.

### 2) Validation of the Day-ahead Solution

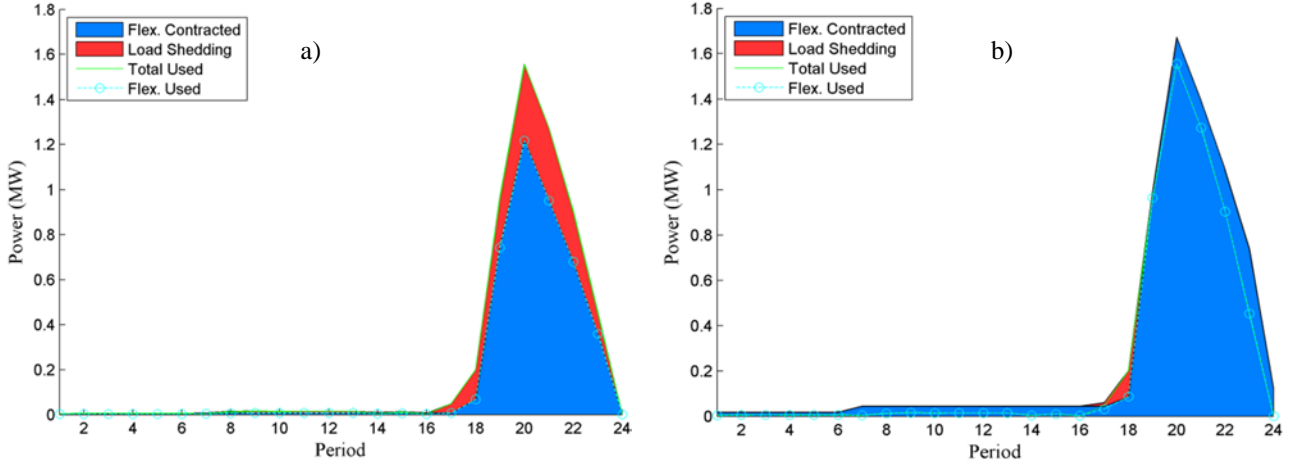

Fig. 5. Contracted, used flexibility and load shedding (in expectation) over 24-hour for a) deterministic and b) robust (6 vertices) approaches under real-time operation.

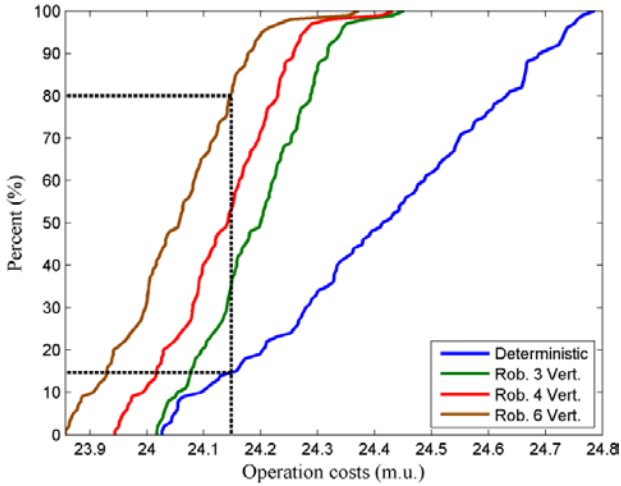

Fig. 6. Empirical cumulative distribution function of expected operating costs for deterministic (blue line), robust 3 vertices (green line), robust 4 vertices (red line) and robust 6 vertices (brown line) approaches.

The validation stage entails performing an hourly optimal power flow considering out-of-sample data of wind and PV and the reserved/contracted flexibilities by the DSO. One hundred new wind and PV realization scenarios have been generated based on the real measurement data, accounting with upward and downward deviations of 20% from the measurement data.

Besides this, only the flexibility contracted by the DSO to the aggregators can be used during the validation stage. Flexibility contracted is used to solve congestion in the system. In cases where contracted flexibility is not enough to solve the congestion problem, wind and PV curtailment and load shedding are used to balance the system as last resort measures. From this, it is possible to evaluate the robustness of the proposed solution and compare with the traditional deterministic approach. The traditional approach relies on an OPF scheduling based on point forecast information. Table VIII shows the total expected operating costs of each approach after the validation process. One can see that, as expected, the robust approach ensures lower operating costs than the traditional DSO approach (1.07% more efficient). This is due to the broad flexibility that is scheduled under the worst-case

of the robust approach in each hour.

Comparing the results of the traditional and the robust approach under the day-ahead scheduling and during the validation process (Table VII and Table VIII), one can verify that robust approaches reserve more flexibility during the day-ahead scheduling that can be used during the validation process, resulting in lower expected operating costs after the validation stage. Thus, in this case study, from a financial point of view, the proposed approach is better than the traditional deterministic DSO approach (present-day practice). For instance, if the DSO chooses the robust approach instead of the deterministic in the day-ahead market for 0.341 m.u. more (24.063-23.722, Table VII), it would have a saving of 0.360 (24.413-24.053, Table VIII) in the validation stage, which means 0.019 m.u. of net saving.

Although the cost savings are small since the case study is a daily analysis, a yearly analysis can represent a significant saving for the DSO. However, it is possible that a different case study may show distinct behavior. That is, in cases with low levels of uncertain production and congestion problems, robust approach may be more expensive, yet ensuring high levels of system reliability. Additionally, the proposed approach also ensures higher reliability by requiring less load shedding than the traditional approach.

The behavior of the deterministic approach under the validation process for the 24-hour period is illustrated in Fig. 5 a). The blue area represents the flexibility contracted at the day-ahead stage, while the red area shows the load shedding used by the deterministic approach during the validation. The green line represents the total power used by the DSO to manage the grid during the validation process, while the blue line shows the flexibility used by the deterministic approach during the validation process. One can see that the flexibility contracted in the day-ahead is not enough to solve the congestion problem that occurred during the real-time operation. Thus, load shedding is used by the DSO to manage this congestion.

Fig. 5 b) depicts the behavior of the proposed approach under the validation process. One can see that, in most of the periods, the contracted flexibility is more than enough to solve congestion problems that occur during real-time operation.

However, between 17 and 18 periods, there is a need for extra power to solve congestion. Thus, load shedding is used to manage the congestion, accounting for a high penalty.

Comparing the results of the deterministic - Fig. 5 a) - and proposed - Fig. 5 b) - approaches, one can identify different behavior and portions of the scheduled and used flexibility. The proposed approach reserves more flexibility than the deterministic approach, which is useful during the real-time operation. Thus, the proposed approach infers less operating costs than the equivalent deterministic approach after the validation process due to the lower need of load shedding (extremely expensive) to manage congestion in the system.

In more detail, the difference between the expected operating costs of the deterministic and robust approaches is illustrated in Fig. 6. From the cumulative distribution function it is possible to evaluate the probability of the scenarios occurring in a range of expected operating costs. For instance, an expected operating cost of up to 24.148 m.u. is expected to happen in 80% of the scenarios for the robust 6 vertices approach, while the same cost is most likely to occur in 14.69% of the scenarios for the deterministic approach. This highlights the effectiveness of the proposed approach to the problem. Additionally, one can see that there is always need for flexibility, and therefore the deterministic approach presents worst results than robust approaches. Moreover, it is noteworthy that the proposed methodology allows the DSO to control the number of vertices, thereby to some extent controlling the robustness of the obtained solution.

### 3) Computational Performance

The computations were carried out with DICOPT [34] as an MINLP solver on an Intel Core i5 2.70 GHz processor with 8 GB RAM. All modeling was performed in the GAMS [35] modeling language. The deterministic approach was performed for 8 minutes, while the robust 3, 4 and 6 vertices were performed for 2.5h, 6.4h and 16.2h, respectively. The robust approach takes a high computational time to converge, due to the complexity of the proposed formulation.

One way of reducing the complexity of the methodology is through linearization of the non-linearity. In this way, the AC OPF can be formulated in the format of a second-order cone programming [36] or semidefinite programming [37], which are convex models that can be efficiently solved. However, these models usually give approximate solutions for the non-linear solution. Improved methods, such as strong second-order cone programming relaxations based on McCormick relaxation to improve the approximation of the convex region of bilinear constraints have been emerging. Such advanced methods, reduce the optimality gap in relation to the traditional non-linear models [38]. Other recent developments in AC OPF can be found in [39].

On the other hand, the computational performance can also be improved by considering different optimization algorithms, such as meta-heuristics. These optimization algorithms are somehow able to provide approximate solutions of the AC OPF problem, requiring less computational effort to solve the problem [40].

Nevertheless, a combination of reducing the complexity of the problem through mathematical optimization techniques and the use of meta-heuristics to improve the computational

performance is the most likely evolution for the proposed methodology.

## V. CONCLUSIONS

The increasing the flexibility of DER will allow the DSO to reserve this flexibility to handle local technical problems in the distribution system, thereby, improving security of supply.

This work proposes a new method for DSO distribution grid management under spatial-temporal uncertainty. It is assumed that the DSO applies a preventive approach on grid management by reserving flexibility from DER at the day-ahead stage. The results show that such an approach is more expensive than present-day practice at the day-ahead stage, but cheapest on the operating day, i.e. the robust approach provides savings in the DSO operating costs by reserving some flexibility at the day-ahead stage to be used during real-time operation, avoiding extra penalties. In addition, results show that the level of robustness depends on the modeling of the uncertainty set, i.e. the number of vertices of the uncertainty set to use in the optimization process. However, the price of robustness is paid in the computational effort. An important conclusion from this work is that robust solutions increase the reliability of the distribution system, representing a preventive approach for grid management.

Nevertheless, the use of this methodology by the DSO requires a yearly evaluation between the costs saved by this approach and its usefulness (perhaps, measured by the number of events in a year where the method is useful). Thus, future work should focus on this trade-off, as well as on improving the computational performance of the optimization algorithm, potentially by combining meta-heuristics with mathematical optimization techniques to assure tractable, robust solutions.

## APPENDIX

The general adaptive robust optimization for a single period is formulated as the following three-level optimization problem:

$$\min_x C^{DA}x + \max_u \min_y C_t^{RT}y \quad (5a)$$

$$s.t. Tx + Hy = u : \lambda, \quad (5b)$$

$$y \geq 0 : \mu, \quad (5c)$$

$$s.t. u \in W \quad (5d)$$

$$s.t. Ax \leq a, \quad (5e)$$

$$x \geq 0, \quad (5f)$$

where  $T$  and  $H$  are matrices defining the left-hand-side of recourse constraints,  $\lambda$  and  $\mu$  are vectors of Lagrange multipliers associated with equalities and inequalities constraints of recourse stage.  $A$  is a matrix defining the left-hand-side of first stage constraints and  $a$  is a vector defining the right-hand-side of first stage constraints.

Considering that the optimization problem from (5) cannot be solved directly given its min-max-min structure, the inner minimization problem can be replaced by its dual formulation. Thus, the optimization problem assumes the form of

$$\min_x C^{DA}x + \max_u \max_y (u - Tx)^T \lambda \quad (6a)$$

$$s.t. H^T y + \mu = C^{RT}, \quad (6b)$$

$$\mu \geq 0, \quad (6c)$$

$$u \in W \quad (6d)$$

$$s.t. Ax \leq a, \quad (6e)$$

$$x \geq 0, \quad (6f)$$

The two-level formulation in (6) is more complex due to the presence of the bilinear term arising as the product of the dual variable  $\lambda$  and the uncertain parameter  $u$  in the objective function. However, following the proof on [18] the optimal solution will be at one of the vertices of the polyhedral uncertainty set  $W$ . In addition, the vector  $x$  of first stage variables do not appear in the constraints of the single maximization problem, so the feasible polyhedral is independent of the first stage decisions, thereby it has a finite number of vertices  $s = 1, \dots, N_s$ . Thus a variable  $\beta$  representing the worst-case recourse cost can be added to the model, replacing the max-max problem, such as

$$\min_x C^{DA} x + \beta \quad (7a)$$

$$s.t. \beta \geq C^{RT} y_s, \quad \forall s \in \{1, \dots, N_s\}, \quad (7b)$$

$$Tx + Hy_s = u_s, \quad \forall s \in \{1, \dots, N_s\}, \quad (7c)$$

$$y_s \geq 0, \quad \forall s \in \{1, \dots, N_s\}, \quad (7d)$$

$$Ax \leq a, \quad (7e)$$

$$x \geq 0, \quad (7f)$$

where all the recourse constraints (7b) to (7d) are listed for all vertices  $s$  of the uncertainty set.

## REFERENCES

- [1] T. Ackermann, G. Andersson, and L. Söder, "Distributed generation: A definition," *Electr. Power Syst. Res.*, vol. 57, no. 3, pp. 195–204, 2001.
- [2] I. J. Pérez-Arriaga, S. Ruester, S. Schwenen, C. Battle, and J.-M. Glachant, "From distribution networks to smart distribution systems: rethinking the regulation of european electricity DSOs," *THINK Proj.*, pp. 1–88, 2013.
- [3] Eurelectric, "Active distribution system management: a key tool for the smooth integration of distributed generation," *Eurelectric*, pp. 1–53, 2013.
- [4] D. Six, A. Ramos, and E. R. Puente, "Evaluation of current market architectures and regulatory frameworks and the role of DSOs," *Deliverable D1.2, European Project evolVDSO*, 2014. [Online]. Available: <http://www.evoldso.eu/Home/Results>.
- [5] D. Bertsimas, E. Litvinov, X. A. Sun, J. Zhao, and T. Zheng, "Adaptive robust optimization for the security constrained unit commitment problem," *Power Syst. IEEE ...*, vol. 28, no. March, pp. 1–8, 2013.
- [6] M. Zugno and A. J. Conejo, "A robust optimization approach to energy and reserve dispatch in electricity markets," *Eur. J. Oper. Res.*, vol. 247, no. 2, pp. 659–671, 2015.
- [7] M. Bazrafshan and N. Gatsis, "Decentralized stochastic optimal power flow in radial networks with distributed generation," *IEEE Trans. Smart Grid [under Revis.]*, pp. 1–14, 2016.
- [8] Y. P. Agalgaonkar, B. C. Pal, and R. A. Jabr, "Stochastic distribution system operation considering voltage regulation risks in the presence of PV generation," *IEEE Trans. Sustain. Energy*, vol. 6, no. 4, pp. 1315–1324, 2015.
- [9] C. S. Saunders, "Point estimate method addressing correlated wind power for probabilistic optimal power flow," *IEEE Trans. Power Syst.*, vol. 29, no. 3, pp. 1045–1054, 2014.
- [10] A. Ulian, M. Sebastian, G. Bartolucci, and C. Gutshi, "Business use cases definition and requirements," *Deliverable D2.1, EU Project evolVDSO*, 2014. [Online]. Available: <http://www.evoldso.eu/Home/Results>.
- [11] A. I. Chrysochos, G. C. Kryonidis, E. O. Kontis, C. S. Demoulias, and G. K. Papagiannis, "Dynamic equivalent models for the simulation of controlled DRES," *Deliverable D*, 2014. [Online]. Available: <http://www.project-increase.eu/index.php?cmd=s&id=74>.
- [12] A. Madureira, R. Bessa, J. Meirinhos, D. Fayzur, J. Filipe, A. A. Messias, D. A. Lopes, and P. G. Matos, "The impact of solar power forecast errors on voltage control in smart distribution grids," in *23rd International Conference on Electricity Distribution (CIRED 2015), Lyon, France, 2015*.
- [13] J. Tastu, P. Pinson, and H. Madsen, "Space-time trajectories of wind power generation: Parameterized precision matrices under a Gaussian copula approach," in *Modeling and Stochastic Learning for Forecasting in High Dimensions*, vol. 217, Springer, 2015, pp. 267–296.
- [14] G. Michalke and A. D. Hansen, "Grid support capabilities of wind turbines," in *Handbook of Wind Power Systems*, Springer, 2014, pp. 569–590.
- [15] K. Knorr, B. Zimmermann, D. Kirchner, M. Speckmann, R. Spieckermann, M. Widdel, M. Wunderlich, R. Mackensen, K. Rohrig, F. Steinke, P. Wolfrum, T. Leveringhaus, T. Lager, L. Hofmann, D. Filzek, T. Göbel, B. Kusserow, L. Nicklaus, and P. Ritter, "Kombikraftwerk 2 – final report," 2014.
- [16] Windvision, Enercon, Eneco, and Elia, "Delivery of downward aFRR by wind farms," 2015.
- [17] T. Soares, P. Pinson, T. V. Jensen, and H. Morais, "Optimal offering strategies for wind power in energy and primary reserve markets," *IEEE Trans. Sustain. Energy*, vol. 7, no. 3, pp. 1–10, 2016.
- [18] J. M. Morales, A. J. Conejo, H. Madsen, P. Pinson, and M. Zugno, "Integrating renewables in electricity markets - operational problems," *Springer*, vol. 205, p. 429, 2014.
- [19] Y. Guan and J. Wang, "Uncertainty sets for robust unit commitment," *IEEE Trans. Power Syst.*, vol. 29, no. 3, pp. 1439–1440, 2014.
- [20] C. B. Barber, D. P. Dobkin, and H. Huhdanpaa, "The quickhull algorithm for convex hulls," *ACM Trans. Math. Softw.*, vol. 22, no. 4, pp. 469–483, 1996.
- [21] D. H. Douglas and T. K. Peucker, "Algorithms for the reduction of the number of points required to represent a digitized line or its caricature," *Cartogr. Int. J. Geogr. Inf. Geovisualization*, vol. 10, no. 2, pp. 112–122, 1973.
- [22] J. Hershberger and J. Snoeyink, "Speeding up the Douglas-Peucker line-simplification algorithm," in *5th International Symposium on Spatial Data Handling*, 1992, pp. 134–143.
- [23] H. Haghghat and S. W. Kennedy, "A model for reactive power pricing and dispatch of distributed generation," in *IEEE PES General Meeting, PES 2010, Minneapolis, US*, 2010, pp. 1–10.
- [24] ERSE, "Despacho nº 7253/2010," *Diário da República [in Portuguese]*, 2010. [Online]. Available: [http://www.erse.pt/pt/legislacao/Legislacao/Attachments/1411/Despacho7253\\_2010.pdf](http://www.erse.pt/pt/legislacao/Legislacao/Attachments/1411/Despacho7253_2010.pdf).
- [25] S. B. Peterson, J. F. Whitacre, and J. Apt, "The economics of using plug-in hybrid electric vehicle battery packs for grid storage," *J. Power Sources*, vol. 195, no. 8, pp. 2377–2384, 2010.
- [26] H. Morais, T. Sousa, J. Soares, P. Faria, and Z. Vale, "Distributed energy resources management using plug-in hybrid electric vehicles as a fuel-shifting demand response resource," *Energy Convers. Manag.*, vol. 97, pp. 78–93, 2015.
- [27] R. N. Allan, R. Billinton, I. Sjarief, L. Goel, and K. S. So, "A reliability test system for educational purposes - basic distribution-system data and results," *Ieee Trans. Power Syst.*, vol. 6, no. 2, pp. 813–820, 1991.
- [28] European Climate Foundation, "Roadmap 2050: A practical guide to a prosperous, low-carbon Europe," 2010.
- [29] Y. J. Zhang and Z. Ren, "Optimal reactive power dispatch considering costs of adjusting the control devices," *IEEE Trans. Power Syst.*, vol. 20, no. 3, pp. 1349–1356, 2005.
- [30] P. Pinson, "Wind energy: forecasting challenges for its operational management," *Stat. Sci.*, vol. 28, no. 4, pp. 564–585, 2013.
- [31] W. A. Bukhsh, C. Zhang, and P. Pinson, "Data for stochastic multiperiod opf problems." [Online]. Available: <https://sites.google.com/site/datasmpopf/>.
- [32] R. J. Bessa, A. Trindade, and V. Miranda, "Spatial-temporal solar power forecasting for smart grids," *IEEE Trans. Ind. Informatics*, vol. 11, no. 1, pp. 232–241, 2015.
- [33] P. Pinson, H. Madsen, H. A. Nielsen, G. Papaefthymiou, and B. Klöckl, "From probabilistic forecasts to statistical scenarios of short-term wind power production," *Wind Energy*, vol. 12, no. 1, pp. 51–62, 2009.

- [34] A. Vecchiotti, I. Grossmann, R. Raman, and E. Kalvelagen, "DICOPT solver," *Carnegie Mellon Univ. GAMS Dev. Corp.*, 2008.
- [35] R. Rosenthal, *GAMS – a user's guide*. Washington, DC: GAMS Development Corporation, 2008.
- [36] M. S. Lobo, L. Vandenberghe, S. Boyd, and H. Lebret, "Applications of second-order cone programming," *Linear Algebra Appl.*, vol. 284, no. 1–3, pp. 193–228, 1998.
- [37] S. H. Low, "Convex relaxation of optimal power flow - Part I: Formulations and equivalence," *IEEE Trans. Control Netw. Syst.*, vol. 1, no. 1, pp. 15–27, 2014.
- [38] B. Kocuk, S. S. Dey, and X. A. Sun, "Strong SOCP Relaxations for the Optimal Power Flow Problem," *Oper. Res.*, pp. 1–20, 2016.
- [39] F. Capitanescu, "Critical review of recent advances and further developments needed in AC optimal power flow," *Electr. Power Syst. Res.*, vol. 136, pp. 57–68, 2016.
- [40] S. Frank, I. Steponavice, and S. Rebennack, "Optimal power flow: a bibliographic survey II," *Energy Syst.*, vol. 3, no. 3, pp. 259–289, 2012.



APPENDIX **F**

## Paper F

---

**Title:**

Optimal offering and control policies for wind power in energy and reserve markets

**Authors:**

Tiago Soares, Tue V. Jensen, Nicolò Mazzi, Pierre Pinson and Hugo Morais

**Published in:**

Wind Energy (under review).

# Optimal offering and control policies for wind power in energy and reserve markets

Tiago Soares<sup>1</sup>, Tue V. Jensen<sup>1</sup>, Nicolò Mazzi<sup>2</sup>, Pierre Pinson<sup>1</sup>, Hugo Morais<sup>3</sup>

<sup>1</sup>Department of Electrical Engineering, Technical University of Denmark, Kgs. Lyngby, Denmark

<sup>2</sup>Department of Industrial Engineering, University of Padova, Padova, Italy

<sup>3</sup>Department of Electrical Engineering, Polytechnic Institute of Porto, Porto, Portugal

## Abstract

Proliferation of wind power generation is increasingly making this power source an important asset in designs of energy and reserve markets. Intuitively, wind power producers will require the development of new offering strategies that maximize the expected profit in both energy and reserve markets while fulfilling the market rules and its operational limits. In this paper, we implement and exploit the controllability of the proportional control strategy. This strategy allows the splitting of potentially available wind power generation in energy and reserve markets. In addition, we take advantage of better forecast information from the different day-ahead and balancing stages, allowing different shares of energy and reserve in both stages. Under these assumptions, different mathematical methods able to deal with the uncertain nature of wind power generation, namely stochastic programming, with McCormick relaxation and piecewise linear decision rules are adapted and tested aiming to maximize the expected revenue for participating in both energy and reserve markets, while accounting for estimated balancing costs for failing to provide energy and reserve. A set of numerical examples, as well as a case-study based on real data, allow the analysis and evaluation of the performance and behavior of such techniques.

An important conclusion is that the use of the proposed approaches offers a degree of freedom in terms of minimizing balancing costs for the wind power producer strategically to participate in both energy and reserve markets.

## Keywords

Energy and reserve markets; offering strategies; piecewise linear decision rules; stochastic programming; wind power

## Nomenclature

The main notation used throughout the paper is stated next for quick reference. Other symbols are defined as required.

### Parameters

$\varepsilon$             Coefficient to control the share deviation between both stages



$\lambda$	Prices, penalties and unit costs for wind power producers
$\lambda^{cap}$	Capacity price for power reserve
$\lambda^{sp}$	Spot price for energy
$\pi_w$	Probability in each scenario $w$
$G$	Lifted support PLDR
$L$	Lifting operator PLDR
$P^{Max}$	Maximum total power offer
$P^{Min}$	Minimum total power offer
$Q_w^*$	Eventually observed wind power in scenario $w$
$r_i$	Line segment PLDR
$V$	Square matrix with $(r+1)*(r+1)$ dimensions for PLDR
$\hat{W}$	Conditional mean forecast of the wind power distribution
$z_j^i$	Breakpoints for PLDR

### Subscript

$w$	Wind scenario
$i, j$	Number of lines

### Superscript

+	Positive deviation for being long (down-regulation)
-	Negative deviation for being short (up-regulation)
*	Balancing stage
$bpt$	Unit penalty cost for the wind power producer
$c$	Day-ahead stage
$pt$	Penalty for reserve imbalance

### Variables

$\alpha$	Control strategy (proportional share)
$\delta$	Random variable in PLDR
$\Delta E$	Energy deviation
$\Delta R$	Reserve deviation
$\mu$	Dual variable associated to the inequality constraints in PLDR
$E$	Energy offer
$K$	Slope of the linear function for PDLR
$Q$	Total power offer
$R$	Power reserve offer

## 1. Introduction

In many countries, electricity markets are facing the challenge of integrating renewable power (mainly, wind power) into the system while taking into consideration the uncertain production of these type of power plants. Wind power has reached considerable levels of penetration in some

power systems, but most of the wind power is not yet fully competitive in the electricity markets because of feed-in tariffs.

Nevertheless, competition in the energy market has been increasing, since wind power plants have grown year after year. Thus, decision-making tools for wind power producers (WPPs) offering in the energy market have been developed in the last few years. In this respect, a large number of studies pursuing an optimal offering strategy for the WPPs in the day-ahead market, accounting with potential balancing costs (assuming a price-taker behavior) can be found in literature. Studies examine the use of strategies for maximizing the expected utility of wind power [1,2], strategies considering risk-analysis and temporal dependencies [3,4], offering in the one-price and two-price system [5], as well as offering under opportunity cost in the imbalance system [6], and many other aspects [7–10]. On the other hand, optimal strategies under the price-maker assumption have emerged [11–16]. Some of these strategies exploit the equilibrium in oligopolistic markets [15] or assume a risk-constrained behavior [16].

Currently, wind power technology allows the WPPs to allocate some of the available power to provide a reserve, thereby enabling them to support some type of ancillary services [17–19]. Thus, different control techniques for the curtailment of the wind power production have arisen in literature, such as proportional and constant control [20], as well as,  $\Delta P$  and output cap control [21]. Furthermore, this ability will be in new business models for WPPs, since they are now able to initiate their participation in reserve markets. Thus, promising opportunities for increasing revenues by offering in two market products can be exploited. In this new context, with WPPs offering in both energy and reserve markets, it is crucial to develop methods for the optimal offering of wind power in both markets. In this way, some studies have emerged on joint offering of energy and reserve under uncertain production [22–25]. A multi-stage stochastic approach for evaluating under risk analysis the joint participation of wind in both the energy and reserve markets is proposed in [22]. Liang *et al.* [23] developed an analytical approach (based on the multi-newsvendor problem with budget constraint), but assumed that participation in the energy and reserve markets can be independently determined based on a budget constraint. In contrast, an analytical and stochastic approach for determining the wind offer in both energy and reserve markets, assuming wind correlation in both markets (under different control strategies) is proposed in [24] and [25], respectively.

Notwithstanding this, to the best of our knowledge, none of the existing works simultaneously exploits the controllability of control strategies and takes advantage of better forecast information from the different day-ahead and balancing stages in the joint energy and reserve wind offering problem. Thus, this paper exploits the controllability of the proportional control strategy in the day-ahead and balancing markets, taking advantage of the strategy simplicity to implement it in practice (as discussed in [20]). Under this control strategy, we prove that allowing use of different share parameters for energy and reserve between both the day-ahead (first-stage) and balancing markets (second-stage) can result in extra income for the WPPs. Furthermore, this work adapts, tests and validates a number of different approaches (fixed stochastic, flexible stochastic, McCormick relaxation and piecewise linear decision rules – PLDR) for optimal identification of the share of energy and reserve for the WPPs in both the energy and reserve markets. The fixed stochastic approach considers a fixed share of energy and reserve in both market stages and serves as the basis

for comparison with the remaining methods. Moreover, all proposed methods are demonstrated, validated and compared on the basis of numerical examples (as well as on a case study based on real-data), while seeking to improve the income of the WPPs, as well as the wind power participation in a wide range of services in electricity markets. This allows increased penetration in the power system.

The paper is organized as follows. Section 2 briefly introduces wind power participation in the energy and reserve markets, detailing the impact and required market changes for allowing WPPs to participate in the reserve market. Section 3 presents the general formulation for wind power revenue in both the energy and reserve markets. Section 4 describes in detail the proposed approaches (i.e. the fixed and flexible stochastic, the McCormick and PLDR methods). Section 5 verifies, tests and compares all approaches on a set of numerical examples, as well as on a case study concerning real data. Finally, conclusions and future work are gathered in Section 6.

## 2. Wind offering in energy and reserve markets

The current developments in wind-turbine technology have encouraged the WPPs to show interest in the reserve market, thereby seeking extra revenues. New supply of different market products has encouraged the WPPs to rethink their strategic behavior in the wholesale market. On the one hand, the WPPs may split their available wind power into different markets to improve profit and reduce the risk of participating on one single product. On the other hand, potential penalties for power balancing deviations in both market products must be taken into account to avoid significant penalties that may reduce the expected income from both market products.

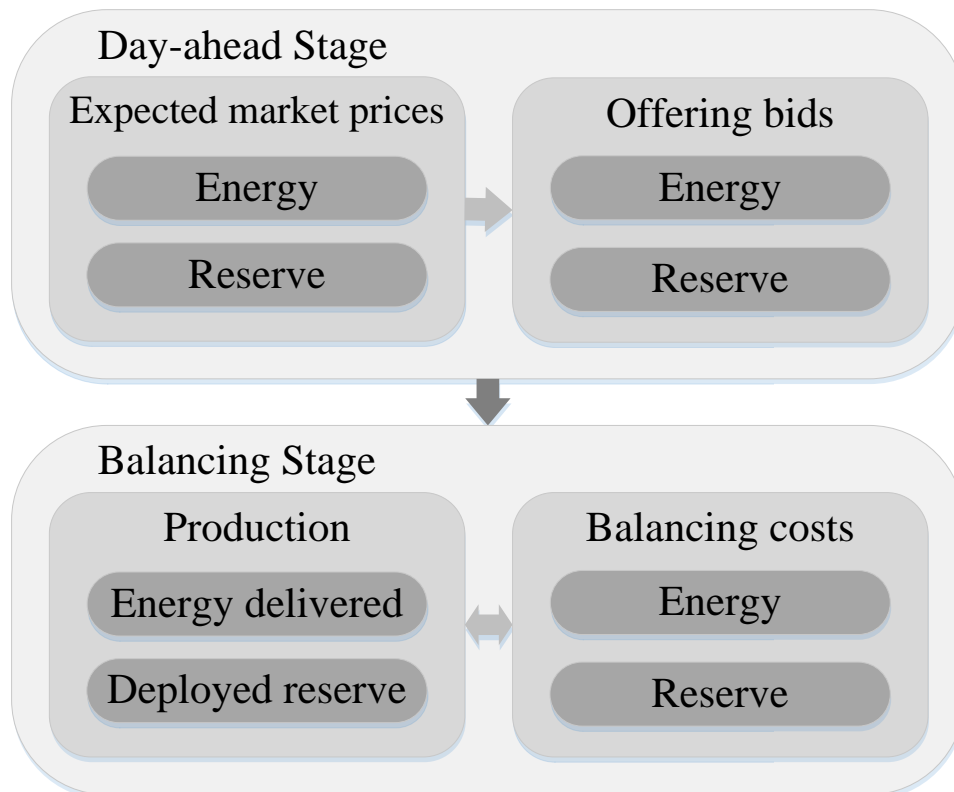

**Figure 1.** Wind power model in the energy and reserve markets.

In this respect, a strategic market model for the WPPs to participate in the energy and reserve markets is studied. This model allows WPPs to offer their bids for energy and reserve in the day-ahead market while accounting with expected balancing costs for missing expected production of energy and reserve during the balancing stage (Fig.1). Additionally, (through control strategies) the model allows that the share of energy and reserve established in the day-ahead stage (ratio between energy and reserve) can be different in the balancing stage, thereby allowing WPPs to minimize their power deviations while reducing expected balancing costs. This model characteristic is important in that it allows WPPs to use better information about their wind power forecast (closer to the energy delivery) to define the share of energy and reserve assumed in the balancing stage. In more detail, this flexibility allows WPPs to push decisions close to the real-time, thereby improving the quality of their decisions and reducing the lead time effect between the day-ahead decisions and the energy and services delivered.

In terms of system reliability, this flexible characteristic of the model may reduce to some extent the uncertainty of the wind power production, since it uses better forecast information (closer to real-time) to define the energy and reserve share in the balancing stage. Thus, the flexible approach can decrease the energy and reserve deviations between day-ahead and balancing stage in comparison to the approach of same energy and reserve share between the day-ahead and balancing stage. This means that, to some extent, the level of reserve needed in the system can be slightly reduced if the wind power producer can change its energy and reserve share.

However, this strategic offering will require some changes in current market rules. For instance, the WPPs should be allowed to offer in the reserve market in a strategic way. A smart and smooth way of introducing wind power in current reserve markets is to allow the WPPs and conventional generators to jointly offer in the reserve market. Thus, conventional generators can be used to some extent to cover the uncertainty of the wind power producer. However, further changes are still required for full participation of wind power in the reserve market. For example, introducing a new reserve penalty scheme to penalize WPPs for power deviations in the reserve market could force uncertain WPPs to offer their potential available power with some level of certainty, as suggested in [23,24] and implemented in the proposed model. Furthermore, the reserve market design with high penetration of uncertain generation may require operating closer to the delivery, since reserve requirements may dynamically vary on and hourly or even minute-by-minute basis [26]. Thus, WPPs will very probably be called (even forced to some extent) to contribute under these new service conditions. In this context, the flexible characteristic proposed in this work may to some extent cover the participation of WPPs in these new market features, where market decisions are made closer and closer to the delivery.

### **3. General formulation of market revenues**

A general formulation for the revenue of the WPPs in energy and reserve markets is presented in [24]. Following a stochastic programming approach from that, the maximization of the revenue from day-ahead and reserve markets, accounting for the penalties from the balancing market can be expressed as

$$Rev = \lambda^{cap} R^c + \sum_{w \in \Omega} \pi_w \left[ \lambda^{sp} E_w^* - T_w^* - O_w^* \right] \quad (1)$$

where  $\lambda^{sp}$  is the expected spot price,  $E_w^*$  is the amount of expected delivered energy in scenario  $w$ ,  $\lambda^{cap}$  is the expected capacity price for contracting reserve,  $R^c$  is the expected contracted level of power reserve in day-ahead stage,  $T_w^*$  is the balancing costs from the energy deviations,  $Z_w^*$  is the expected penalty cost for failing to provide the scheduled reserve and  $\pi_w$  is the probability in each scenario  $w$ . Time indices are not used, since all variables and parameters are for the same market time unit.

Additionally, it is assumed that the WPP behaves as a price-taker, which means that the production of the WPP is independent of market prices and penalties. Following that behavior and the certainty equivalent theory [9,27], all the prices are linear in the expressions below.

The balancing costs for energy deviations are usually defined as

$$T_w^* = \begin{cases} \lambda^{*,+} (E_w^* - E^c) & E_w^* - E^c \geq 0 \\ -\lambda^{*,-} (E_w^* - E^c) & E_w^* - E^c < 0 \end{cases} \quad (2)$$

where  $(E_w^* - E^c)$  is the energy imbalance between the energy delivered  $E_w^*$  and the energy contracted (offered)  $E^c$ . The variables  $\lambda^{*,+}$  and  $\lambda^{*,-}$  are the regulation unit costs for positive and negative deviations, i.e.,

$$\begin{aligned} \lambda^{*,+} &= \lambda^{sp} - \lambda^{c,+} \\ \lambda^{*,-} &= \lambda^{c,-} - \lambda^{sp} \end{aligned} \quad (3)$$

where  $\lambda^{c,+}$  is the unit down-regulation price for being long, while  $\lambda^{c,-}$  is the up-regulation price for being short. Additionally, we consider the two-price settlement rule as in the NordPool for mapping the balancing costs for energy deviations [1]. The settlement rule is part of the balancing mechanism for pricing the deviations from day-ahead contracts to the delivered production at the balancing stage. One-price and two-price system rules are not discussed in detail in this work. Instead, interested readers are referred to [28]. In cases of negative system imbalance (energy surplus – need for downward regulation), it holds that

$$\begin{aligned} \lambda^{c,+} &\leq \lambda^{sp} \\ \lambda^{c,-} &= \lambda^{sp} \end{aligned} \quad (4)$$

Otherwise, when system imbalance is positive (energy deficit – need of upward regulation), it comes to

$$\begin{aligned} \lambda^{c,+} &= \lambda^{sp} \\ \lambda^{c,-} &\geq \lambda^{sp} \end{aligned} \quad (5)$$

In hours of perfect balance, both  $\lambda^{c,+}$  and  $\lambda^{c,-}$  are equal to the spot price  $\lambda^{sp}$ . In parallel, the costs for the imbalance on the reserve product are formulated based on the one-price system rule (since the penalty for failing to provide this service is directly related to the up/down-regulating price for imbalance of the power reserve), such that

$$O_w^* = \begin{cases} \lambda^{bpt,+} (R_w^* - R^c) & R_w^* - R^c \geq 0 \\ -\lambda^{bpt,-} (R_w^* - R^c) & R_w^* - R^c < 0 \end{cases} \quad (6)$$

where  $(R_w^* - R^c)$  refers to the reserve power imbalance between the realized level of reserve  $R_w^*$  in the balancing stage and the reserve contracted (offered)  $R^c$  in the day-ahead stage.  $\lambda^{bpt,+}$  is the unit penalty for the WPP when generating more power than that contracted (surplus). In contrast,  $\lambda^{bpt,-}$  is the unit penalty cost when the WPP generates less power than that contracted. It holds that

$$\begin{aligned} \lambda^{bpt,+} &= \lambda^{cap} - \lambda^{pt,+} \\ \lambda^{bpt,-} &= \lambda^{pt,-} - \lambda^{cap} \end{aligned} \quad (7)$$

hence  $\lambda^{bpt,+} = 0$  since (extra) positive reserve is not detrimental to the system's reliability.  $\lambda^{pt,-}$  is the penalty for negative reserve imbalance, weighted by the probability that reserve is needed.

## 4. Optimal offer formulation

Although, several wind control techniques have been emerging, few considerations on the strategic implementation of these control techniques in the market perspective have been made [24,25]. As demonstrated in [24], the proportional wind control technique [20] presents a logical and simple strategic behavior in terms of participation in the energy and reserve markets. Thus, we build our different optimization approaches based on this assumption. Furthermore, we have improved the proposed approaches, allowing the WPP to establish different shares of energy and reserve in both the day-ahead and balancing stages.

### 4.1. Flexible stochastic approach

The full flexible stochastic approach for the revenue of WPPs in the energy and reserve markets is given by

$$\max \lambda^{cap} R^c + \sum_{w \in \Omega} \pi_w \left[ \lambda^{sp} E_w^* - \lambda^{*,+} \Delta E_w^+ - \lambda^{*,-} \Delta E_w^- - \lambda^{bpt,-} \Delta R_w^- \right] \quad (10a)$$

$$s.t. \quad P^{Min} \leq Q^c \leq P^{Max} \quad (10b)$$

$$E^c + R^c = Q^c \quad (10c)$$

$$E_w^* + R_w^* = Q_w^* \quad \forall w \in \Omega \quad (10d)$$

$$E^c - E_w^* = \Delta E_w^- - \Delta E_w^+ \quad \forall w \in \Omega \quad (10e)$$

$$R^c - R_w^* \leq \Delta R_w^- \quad \forall w \in \Omega \quad (10f)$$

where  $\Delta E^+$  is the excess of energy incurred by the WPP,  $\Delta E^-$  is the deficit of energy incurred by the WPP,  $\Delta R^-$  is the deficit of reserve incurred by the WPP,  $P^{Min}$  and  $P^{Max}$  are the bounds of the total power offer in the day-ahead stage. This approach is characterized by its total freedom to choose the energy and reserve share in each stage of the problem, i.e. the WPPs can take advantage of the intermediate information about wind power production, thereby reducing the expected costs at the balancing stage. This means that the WPP can adjust the share of energy and reserve in the balancing stage in line with the expected power production in each scenario  $w$ .

## 4.2. Fixed stochastic approach

The fixed stochastic approach relies on the concept of constraining the use of information in the balancing stage to help in the day-ahead decision. For this purpose, the proportional control strategy is used. The control strategy consists in the proportional split of the energy and reserve given by  $\alpha^c$ . In addition to the mathematical formulation from the flexible approach, constraints (11a) to (11e) are included, thus representing the proportional strategy.

$$E^c = \alpha^c Q^c \quad (11a)$$

$$R^c = (1 - \alpha^c) Q^c \quad (11b)$$

$$E_w^* = \alpha_w^* Q_w^* \quad \forall w \in \Omega \quad (11c)$$

$$R_w^* = (1 - \alpha_w^*) Q_w^* \quad \forall w \in \Omega \quad (11d)$$

$$\alpha_w^* = \alpha^c \quad \forall w \in \Omega \quad (11e)$$

where the energy and reserve offered in the day-ahead market is determined in (11a) and (11b), respectively. Both constraints contain bilinear terms (since two different variables are multiplying, the total power offer  $Q^c$  and the control share  $\alpha^c$  which split the total power offer into energy and reserve to offer in the day-ahead market), thus forming a system of bilinear equations which is non-convex. The non-convexity of both equations makes the problem more complex, but it is still feasible with proper solvers. The problem has been carried out with CONOPT [29] as a Non-Linear Programming (NLP) solver.

Besides this, constraints (11c) and (11d) determine the energy and reserve share in the balancing stage for each scenario  $w$ . The fixed behavior of this approach is achieved by assuming that the control parameter for splitting the energy and reserve remains the same in both the day-ahead and balancing stages, i.e.,  $\alpha^* = \alpha^c$ . This constraint (11e) is inferred in the stochastic models as the non-anticipativity constraint, thereby preventing the WPPs from using information close to the balancing stage to influence day-ahead decisions.

## 4.3. Stochastic approach under McCormick relaxation

A hybrid system between the flexible and fixed approach is proposed in this section, with two distinct goals. The first one aims to turn convex the bilinear constraints from the fixed approach by using McCormick relaxation theory [30]. It is noteworthy that McCormick relaxation theory has been chosen among other relaxation techniques due to its ability to provide a tight approximation gap of the bilinear constraints and easy implementation. The second goal aims to control the influence of balancing stage information in the day-ahead decisions, by means of a coefficient to bound the deviation between the share parameter in the day-ahead and balancing stages. This goal emerges with the perspective of giving the WPP some controllability of the use of information close to the real-time, thereby allowing WPPs to quantify the level of anticipatory decision of the balancing stage, which cannot be provided through the fixed or flexible approaches.

Under the assumptions of the fixed stochastic approach, the McCormick relaxation theory [30] is used to relax the bilinear constraints and turn the problem convex. McCormick's relaxation provides a very good approximation of the bilinear terms, ensuring that the problem is convex, and

thereby requiring only traditional Linear Programming (LP) methods to solve the problem, which ensures optimal solutions. Thus, the objective function (10a) is subjected to

$$E^c \geq P^{Min} \alpha_w^* \quad \forall w \in \Omega \quad (12a)$$

$$E^c \leq P^{Min} \alpha_w^* + Q^c - P^{Min} \quad \forall w \in \Omega \quad (12b)$$

$$E^c \leq \alpha_w^* P^{Max} \quad \forall w \in \Omega \quad (12c)$$

$$E^c \geq \alpha_w^* P^{Max} + Q^c - P^{Max} \quad \forall w \in \Omega \quad (12d)$$

$$-\varepsilon \leq \alpha^c - \alpha_w^* \leq \varepsilon \quad \forall w \in \Omega \quad (12e)$$

where (12a) to (12d) is the result of the relaxation of the two bilinear constraints of the fixed approach. On the other hand, the control of the influence of balancing stage information in day-ahead decisions is modeled in (12e), where  $\varepsilon$  is a coefficient that defines the difference between the share parameter in both the day-ahead and balancing stages. The coefficient varies between 0 and 1, thus influencing the behavior of the split between energy and reserve. If  $\varepsilon$  is close to 0, the behavior of this approach is close to the fixed stochastic approach. Otherwise, when  $\varepsilon$  is close to 1, this approach tends to behave similarly to the flexible stochastic approach. Additionally, the model stays complete with the inclusion of (10c) to (10f), and (11c), representing the split of the available power in energy and reserve in both stages, and the deviation of energy and reserve in the balancing stage, respectively.

#### 4.4. Piecewise linear decision rules with axial segmentation

A different and interesting way of modeling the recourse function of the two-stage stochastic problem of WPPs offering in day-ahead market while accounting for balancing costs is through linear decision rules. Linear decision rules are often used to linearly model the uncertainty of the problems, since it can provide tractable upper and lower bounds of the stochastic program. Indeed, the main reason why linear decision rules are used instead of stochastic programming is because it does not need discrete distribution of the uncertain parameter in contrast with stochastic programming. However, the linearization of uncertain variables often comes with rough approximations of the uncertainty, since the uncertainty can behave very differently from linear functions. Thereby, the solution's quality provided by this method can leave much to be desired.

One way to reduce the approximation gap of traditional linear decision rules is by defining uncertainty through a piecewise linear function. This approach increases the flexibility of the LDR method by approximating to the natural recourse function of the problem, however, the problem size grows significantly. An illustrative example of the decisions made by the PLDR is shown in Fig. 2. One can see that the piecewise approach improves the flexibility of the decisions in comparison with simple linear decision rules.



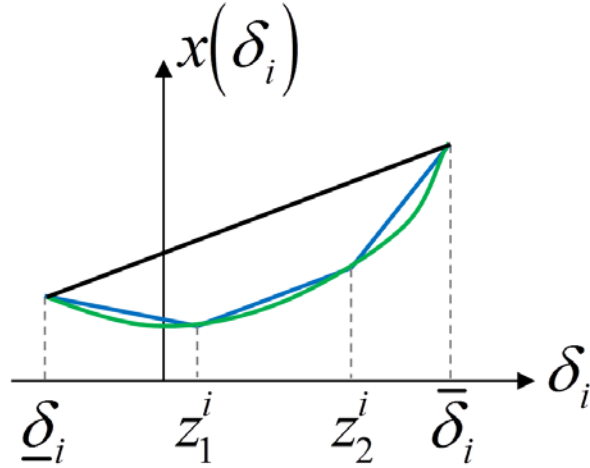

**Figure 2.** Illustrative example of a natural recourse function (green), linear decision rules approximation (black) and piecewise linear decision rules approximation (blue) under the realization of the uncertain parameter.

In this context, we apply the method of piecewise linear continuous decisions rules with axial segmentation, as developed in [31], to ensure that a good linear approximation to the recourse problem is achieved. The method requires the establishment of breakpoints to model the piecewise function. For instance, quantiles of the wind power distribution can be used to define manually these breakpoints. An improved technique of the PLDR (the PLDR with general segmentation) allows optimal estimation of these breakpoints, although the complexity of the problem increases significantly. Thus, we restrict our attention to the PLDR with axial segmentation, by which specific breakpoints for the piecewise function are defined.

The PLDR with axial segmentation idea is to expand the sample space of the uncertain parameter  $\delta_i$  into  $r_i$  lines with  $r_i-1$  breakpoints  $z_j^i$  for  $j \in \{1, \dots, r_i-1\}$  and  $i \in \{1, \dots, k\}$

$$\underline{\delta}_i < z_1^i < \dots < z_{r_i-1}^i < \bar{\delta}_i \quad \forall i \in \{2, \dots, k\} \quad (13a)$$

where  $\underline{\delta}_i$  is the lower bound and  $\bar{\delta}_i$  the upper bound of  $\delta_i$ .

Following [31], one can introduce the lifted space  $\mathbb{R}^{k'}$  of the piecewise linear parameters  $\delta'_i \in \mathbb{R}^{r_i}$  in the lifted support  $G'$ , where  $\delta'_i \in G'$  and  $\delta' = (1, \delta_2'^T, \dots, \delta_k'^T)^T$ .

Thus, the breakpoints are used to define the lifting operator  $L_{i,j}$  as

$$L_{i,j}(\delta) = \begin{cases} \delta_i & \text{if } r_i = 1 \\ \min\{\delta_i, z_1^i\} & \text{if } r_i > 1, j = 1 \\ \max\{\min\{\delta_i, z_j^i\} - z_{j-1}^i, 0\} & \text{if } r_i > 1, j = 2, \dots, r_i - 1 \\ \max\{\delta_i - z_{r_i-1}^i, 0\} & \text{if } r_i > 1, j = r_i \end{cases} \quad (13b)$$

where  $j \in \{1, \dots, r_i\}$  and  $i \in \{2, \dots, k\}$ . The retraction operator converts the lifted parameters into the original parameters through

$$\hat{G}' = \left\{ \delta' \in \mathbb{R}^{k'} : V_i' \begin{pmatrix} 1 \\ \delta'_i \end{pmatrix} \geq 0 \quad \forall i \in \{2, \dots, k\} \right\} \quad (13c)$$



reformulation. By replacing the recourse variables of (10e) with the PLDR previously defined, it gives

$$E^c - \left( \hat{E}^* + \sum_{i=1}^{f_i} K_i^E \delta_i' \right) = \Delta \hat{E}^- + \sum_{i=1}^{f_i} K_i^{\Delta E^-} \delta_i' - \left( \Delta \hat{E}^+ + \sum_{i=1}^{f_i} K_i^{\Delta E^+} \delta_i' \right) \quad (15a)$$

Following [32–34], this equality constraint can be reformulated in a way to eliminate the random variable  $\delta$  and assure finite cardinality, hence

$$E^c - \hat{E}^* = \Delta \hat{E}^- - \Delta \hat{E}^+ \quad (15b)$$

$$-K_i^E = K_i^{\Delta E^-} - K_i^{\Delta E^+} \quad \forall i \quad (15c)$$

Similar reformulation is performed for the other equality constraint (10d), where its final form is assumed as

$$\hat{E}^* + \hat{R}^* = \hat{W} \quad (15d)$$

$$K_i^E + K_i^R = K_i^W \quad \forall i \quad (15e)$$

#### 4.4.2. Inequality constraint reformulation

Let us consider the inequality constraint (10f) of the second stage problem for reformulation. By replacing the PLDR for the recourse decision variables, this inequality can be reformulated as

$$\min_{\delta} \left\{ \begin{array}{l} \sum_{j=1}^r K_j^R \delta_j' + \sum_{j=1}^r K_j^{\Delta R^-} \delta_j' \\ s.t. \sum_{j=1}^r V_{i,(j+1)}' \delta_j' \geq -V_{i,1}' : \mu_i \quad \forall i \end{array} \right\} \geq R^c - \hat{R}^* - \Delta \hat{R}^- \quad (16a)$$

where  $\mu_i$  is the dual variable associated to the  $i$ -th inequality constraint. By applying duality theory [32,35] on the minimization problem on the left-hand-side of the above inequality, one can transform it to the following maximization problem

$$\max_{\mu} \left\{ \begin{array}{l} \sum_{i=1}^{r+1} -V_{i,1}' \mu_i \\ s.t. \sum_{i=1}^{r+1} V_{i,(j+1)}' \mu_i = K_j^R + K_j^{\Delta R^-} \quad \forall j \\ \mu_i \geq 0 \quad \forall i \end{array} \right\} \geq R^c - \hat{R}^* - \Delta \hat{R}^- \quad (16b)$$

The equivalent representation of the above problem in a system of constraints is

$$\sum_{i=1}^{r+1} -V_{i,1}' \mu_i \geq R^c - \hat{R}^* - \Delta \hat{R}^- \quad (17a)$$

$$\sum_{i=1}^{r+1} V_{i,(j+1)}' \mu_i = K_j^R + K_j^{\Delta R^-} \quad \forall j \quad (17b)$$

$$\mu_i \geq 0 \quad \forall i \quad (17c)$$

where the set of inequalities (17) has finite cardinality. Moreover, it is noteworthy that all recourse decision variables (in its piecewise linear form 14b – 14f) from the second stage problem are

positive variables. Thus, it is required performing similar reformulations to all these inequality constraints affected by the uncertainty.

#### 4.4.3. Objective function reformulation

The reformulation of the objective function leads to the employment of the PLDR as expressed in (14). This yields

$$\begin{aligned} \rho = & \lambda^{cap} R^c + \lambda^{sp} \left( \hat{E}^* + \sum_{i=1}^{r_i} K_i^E \mathbb{E}[\delta_i'] \right) \\ & - \lambda^{*+} \left( \Delta \hat{E}^+ + \sum_{i=1}^{r_i} K_i^{\Delta E^+} \mathbb{E}[\delta_i'] \right) - \lambda^{*-} \left( \Delta \hat{E}^- + \sum_{i=1}^{r_i} K_i^{\Delta E^-} \mathbb{E}[\delta_i'] \right) \\ & - \lambda^{bpt,-} \left( \Delta \hat{R}^- + \sum_{i=1}^{r_i} K_i^{\Delta R^-} \mathbb{E}[\delta_i'] \right) \end{aligned} \quad (18a)$$

The expectation over the uncertain parameter for the PLDR is a model based on the lifting operator matrix  $L_{i,j}$  and the probability for each line segment  $\pi^r$

$$\mathbb{E}[\delta_i'] = \sum_{j=1}^{r+1} \left( \frac{L_{j(\underline{z}_i)} + L_{j(\bar{z}_i)}}{2} \right) \pi_i^r \quad (18b)$$

Thus, by replacing the expectation calculus (18b) of the uncertain parameter  $\delta_i'$  in the objective function (18a), one can obtain the final form of the objective function for the PLDR model.

#### 4.4.4. Final model with compact formulation

Finally, the wind offering problem under PLDR assumes its piecewise linear form as

$$\begin{aligned} \max & (18a) \\ \text{s.t.} & (10b), (10c) \\ & (15b) - (15e) \\ & (17a) - (17c) \\ & E^*, P^*, \Delta E^+, \Delta E^-, \Delta P^- \geq 0 \text{ in form of (17)} \end{aligned} \quad (19)$$

where (10b) and (10c) represents the constraints for the first stage decision making process, detailed in section 4.1. Furthermore, all positive second stage decision variables must be in their piecewise linear form and represented by the set of inequalities as in (17).

## 5. Evaluation of wind offering methods

### 5.1. Illustrative case

An illustrative example to test and evaluate the proposed approaches has been performed under specific assumptions and parameters. Supposing a wind power plant of 12 MW with a set of 100 wind power scenarios from [36]. It is assumed that all the wind power scenarios have equal probability. Additionally, a minimum power offer of 3 MW is established as a minimum requirement to participate in the market, ensuring some proper profit to the wind power producer.

Furthermore, a set of prices for energy and reserve, as well as unit costs for energy and reserve deviations during the balancing stage is gathered in Table I.

Table 1

In order to design the piecewise function, a set of breakpoints needs to be defined. For this numerical example, three breakpoints have been established, corresponding to the quantiles of 25%, 50% and 75% of the wind power distribution, respectively.

The behavior of each approach under this test case for offering in the energy market is depicted in Fig. 3. Observe the different behavior for each approach. The fixed stochastic approach places a high offer of energy in the day-ahead market (about 7.8 MWh), while the flexible, McCormick and the PLDR methods place small energy offers, thereby allocating most of the available power to the reserve market. In this case, the fixed approach is the most risk-averse method by offering a high bid in the energy market, to the detriment of participating in the reserve market. The behavior of the fixed method can be explained by the inclusion of the non-anticipativity constraint (fixing the share parameter in both day-ahead and market stages), since it blocks the proper use of the better information about the expected production during the balancing stage. The PLDR approach tends to follow the behavior shown by the flexible and McCormick approaches, however, one can observe the slope change of the linear function around the breakpoints.

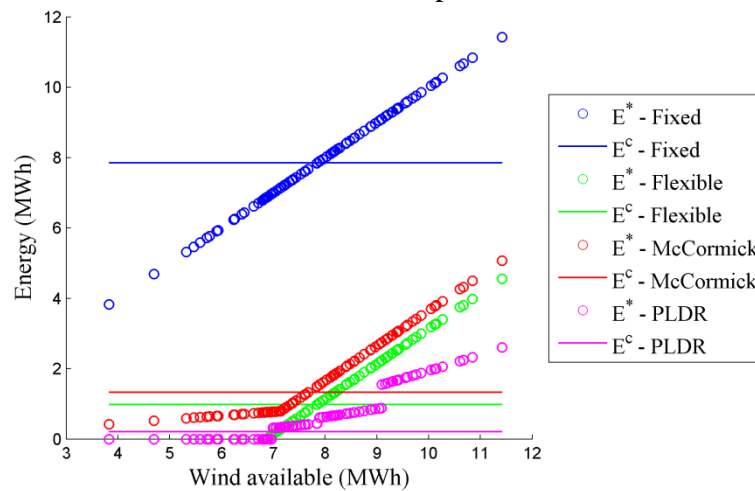

**Figure 3.** Behavior of energy offered ( $E^c$ ) and delivered ( $E^*$ ) in the market for fixed, flexible, McCormick with  $\epsilon=1$  and piecewise linear decision rule methods.

The participation of the wind power producer in the reserve market for each approach is presented in Fig. 4. One can verify that there is no participation in the reserve market through the fixed approach. The fixed approach presents an all-or-nothing behavior, where all the available power is submitted to one single market (energy or reserve, depending on the relation between prices and penalties for deviations). On the other hand, the remaining approaches reserve some power to participate in the reserve market. Thus, the flexible approach is the method that allows a full degree of freedom for the decision making process under the participation in both markets, taking into account penalties in the balancing stage. Furthermore, the McCormick approach presents a very similar behavior to the flexible approach, however the differences in the performance are due to the relaxation of the non-linearity in the proportional strategy.

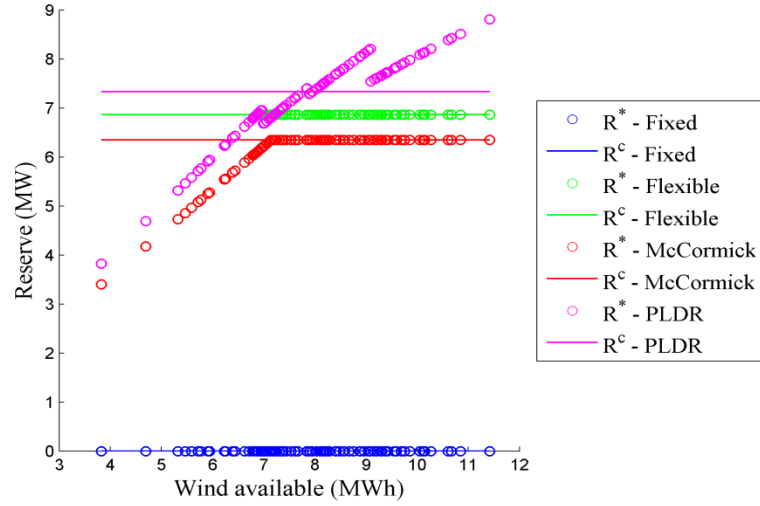

**Figure 4.** Behavior of reserve offered ( $R^c$ ) and deployed ( $R^*$ ) in the market for fixed, flexible, McCormick with  $\varepsilon=1$  and piecewise linear decision rules methods.

It is noteworthy that, for lower levels of wind power available, both flexible and the PLDR approaches fully allocate the available wind power to the reserve market, thereby reducing the expected costs in the balancing stage. i.e. by allocating all the available power to the reserve market, the expected costs in this market will be lower, since the penalty for failing to provide power reserve ( $\lambda^{bpt,-}$ ) is much higher than the penalty for failing to provide energy ( $\lambda^{*,-}$ ). On the other hand, for levels of available wind power higher than the bid offered in the reserve market ( $P^c$ ), both the flexible and McCormick approaches establish the deployed reserve ( $P^*$ ) as equal to that offered in the day-ahead market, then allocating the remaining available power to the energy market. In contrast, the PLDR approach reserves more power in the balancing stage ( $P^*$ ) than is offered in the reserve market ( $P^c$ ), thus assuming a loss opportunity cost for ensuring this robustness.

The parameter representing the share between energy and reserve at day-ahead and balancing stage is shown in Fig. 5. The flexible, McCormick and the PLDR methods have a behavior in which most of the available power is submitted to the reserve market in the day-ahead stage, while in the balancing stage there is a trend to increase the share for providing energy in cases of medium-high levels of the available power (above 7 MW). Permission to establish different share parameters among the trading floors increases the freedom for decision-making, thereby increasing the potential profit.

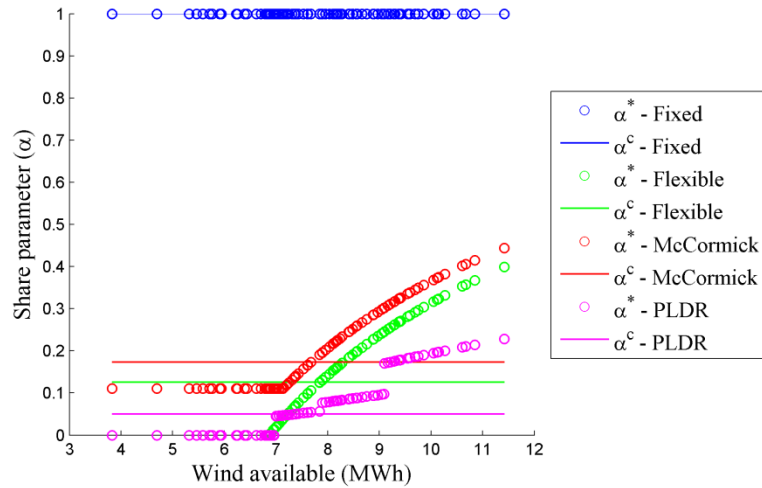
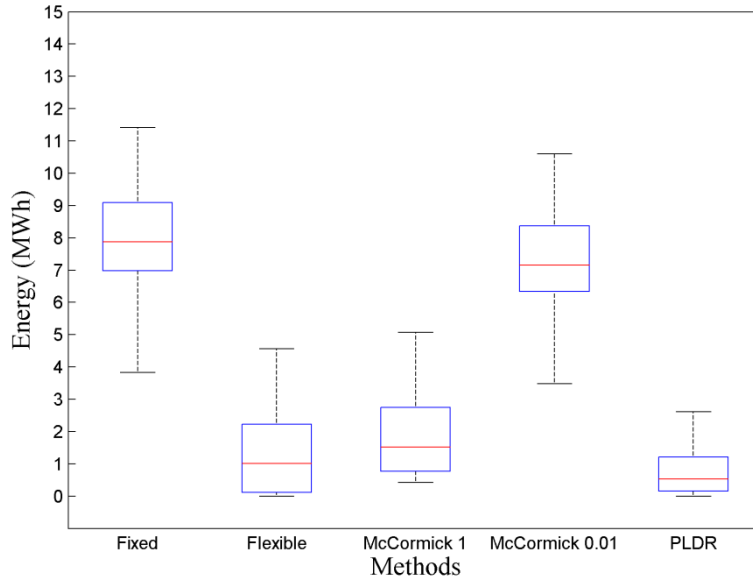

**Figure 5.** Share parameter in the day-ahead ( $\alpha^c$ ) and balancing stage ( $\alpha^*$ ) for fixed, flexible, McCormick with  $\varepsilon=1$  and piecewise linear decision rules methods.

The expected revenue for each method is shown in Table 2. It is noteworthy that the flexible approach has the highest expected revenue, while in the opposite side is the fixed approach. The approach with McCormick relaxation has been performed for different  $\varepsilon$  ( $\varepsilon=1$  and  $\varepsilon=0.01$ ). In more detail, the approach with  $\varepsilon=1$  obtains an expected revenue and behavior close to the flexible approach, while the approach with  $\varepsilon=0.01$  performed closely to the fixed approach results, as expected. This is true, since  $\varepsilon$  defines the deviation between the share parameter in both the day-ahead and balancing stages. The PLDR model obtains expected revenue very close to the fixed approach, although with distinct energy and reserve solutions. The PLDR model could get better expected revenue by allocating more available power (for middle-high levels of available wind power) to the energy market, thereby reducing the loss opportunity cost (i.e. reducing the excess of available power that is reserved).

Table 2

In order to analyze the energy and reserve distributions under potential realization of the wind scenarios, box plots for energy ( $E^*$ ) and reserve ( $R^*$ ) are illustrated in Fig. 6 and Fig. 7, respectively. Thus, Fig. 6 displays the distribution in a standardized way of the expected delivered energy. One can see that each approach has a certain pattern for distributing the available wind power to energy in each scenario. The PLDR approach is the approach with the smaller interquartile range, which means that the dispersion of the data set is closer to the median of the distribution compared with the other approaches. It is noteworthy that the flexible, McCormick with  $\varepsilon=1$  and PLDR approaches just focus on a small part of the available wind power to produce energy than the fixed and McCormick ( $\varepsilon=0.01$ ) approaches. In contrast, the remaining available wind power is allocated to provide a power reserve, as can be seen in Fig. 7.



**Figure 6.** Box plot for energy amounts settled through the balancing stage by the proposed methodologies (fixed, flexible, McCormick with  $\epsilon=1$  and  $\epsilon=0.01$ , and piecewise linear decision rules).

In what concerns the supply of power reserve, the fixed approach does not provide reserve, so the distribution data set of the variable  $R^*$  is 0. From Fig. 7, one can observe a small range of variation in providing reserve, which makes sense, since the penalty for failing to provide reserve is substantially higher than the case of the energy penalties. Thus, the interquartile range is close to zero, i.e. the distribution data is concentrated in the median of the distribution. However, some of the approaches (e.g. flexible, McCormick with  $\epsilon=1$  and PLDR) scheduled low values of reserve in a few scenarios, being such scenarios represented by the suspected outliers and outliers depicted in Fig. 7.

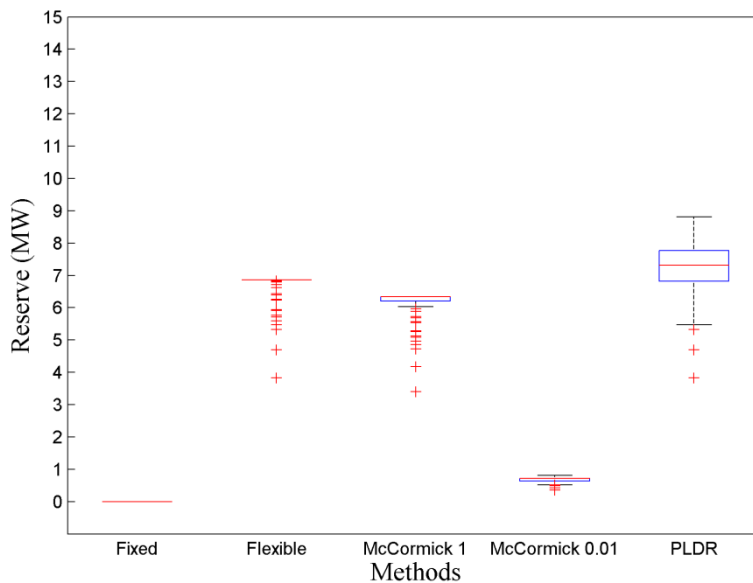
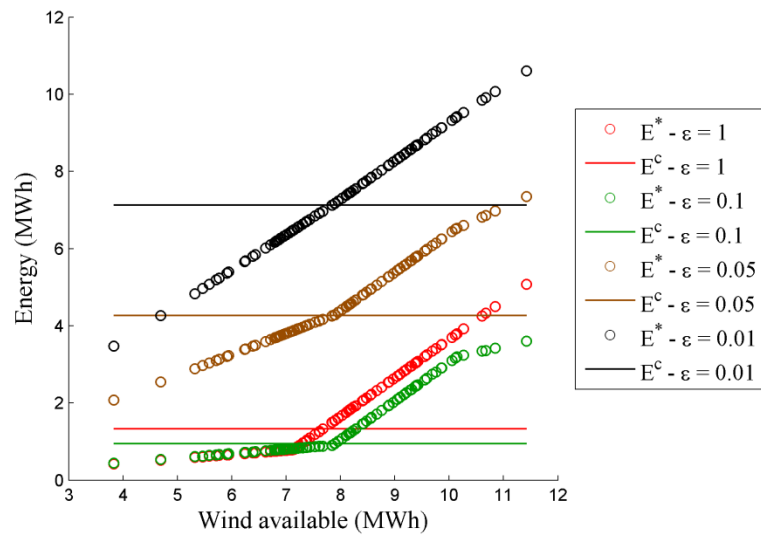

**Figure 7.** Box plot for reserve deployment in the balancing stage by the proposed methodologies (fixed, flexible, McCormick with  $\epsilon=1$  and  $\epsilon=0.01$ , and piecewise linear decision rules).



## 5.2. Sensitivity analysis for McCormick stochastic approach

A sensitivity analysis for the stochastic approach under the McCormick relaxation is performed. We analyze different values for the deviation ( $\epsilon$ ) between the day-ahead and balancing share parameters. Thus, Fig.8 shows the behavior of the energy offered in the day-ahead stage and delivered in the balancing stage for this methodology under different values of  $\epsilon$ . One can observe that, for small deviations of  $\epsilon$  ( $\alpha^c - \alpha_w^*$ ), the energy offered and delivered approximates to the results of the fixed stochastic approach shown in Fig.4, as expected. Besides that, intermediate results are ensured by the methodology with  $\epsilon=0.05$ . It is noteworthy that, as long as the coefficient  $\epsilon$  increases, the methodology results tend to converge to the flexible stochastic approach presented in Fig.4.



**Figure 8.** Energy offered ( $E^c$ ) and delivered ( $E^*$ ) for McCormick approach under different share deviations ( $\epsilon$ ).

The expected offer and deployed reserve for the McCormick approach with different values of  $\epsilon$ , are depicted in Fig.9. As expected, the behavior of this approach in the reserve market is similar to what is presented in Fig.5. As long as the value of  $\epsilon$  decreases, the power offered in the reserve market also decreases. It is noteworthy that there is similar behavior between the approach with  $\epsilon=0.1$  and  $\epsilon=1$ , where a higher level of reserve offer is settled for the approach with  $\epsilon=0.1$ . In a closer view of high levels of available wind power, the approach with  $\epsilon=0.1$  deploys more reserve than that offered in the day-ahead stage, resulting in a loss opportunity cost to the wind power producer.

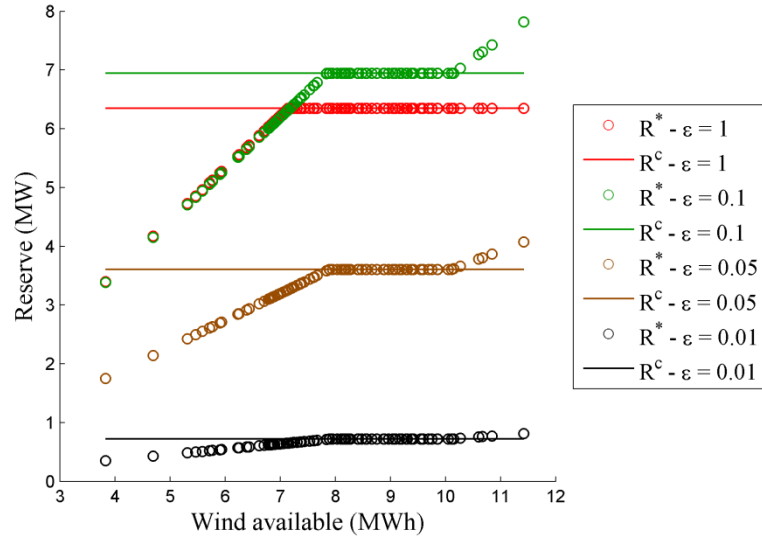

**Figure 9.** Reserve offered ( $R^C$ ) and deployed ( $R^*$ ) for McCormick approach under different share deviations ( $\epsilon$ ).

The performance of the share parameters in both stages is shown in Fig.10. Note that  $\alpha_w^*$  tends to follow the share established in the day-ahead stage. Additionally, it is interesting to note that the performance of the share parameter based on  $\epsilon=1$  and  $\epsilon=0.1$  is very similar. In fact, for lower levels of available wind power (lower than 7 MW), both conjectures get similar results, which means that the constraints concerning  $\epsilon$  are not bidding. Moreover, for the conjecture with  $\epsilon=1$ , it is clear that  $\alpha_w^*$  does not closely follow  $\alpha^c$  due to its degree of freedom in the methodology, while the opposite occurs for the conjecture of  $\epsilon=0.1$  with available wind power lower than 8 MW.

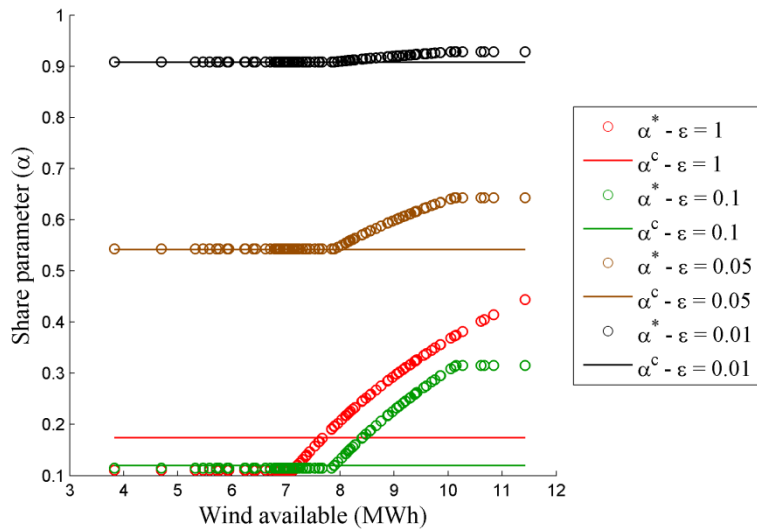

**Figure 10.** Share parameter in the day-ahead ( $\alpha^C$ ) and balancing stages ( $\alpha^*$ ) for the McCormick approach under different share deviations ( $\epsilon$ ).

### 5.3. Analysis of the methodologies under real data

A case study based on a wind power plant with 15 MW of installed capacity participating in the Nord Pool is assumed. The wind data is based on power measurements and a series of 48 h-ahead

point predictions between March 2001 and April 2003 taken from [1]. This data set contains the quantiles of the wind power distribution, as well as the measurement data for 48 h-ahead. To use this data for validation of the proposed methodologies, scenarios need to be generated. Thus, the quantiles for the point predictions were used to generate 100 scenarios for each time interval based on the scenario generation process described in [37]. Besides, prices and penalties for energy and reserve are required. Advance knowledge of the expected prices and penalties is assumed. However and for this specific case, we consider the Nord Pool prices and penalties for the same period of the wind data (between March 2001 and April 2003). It is noteworthy that traditional electricity markets have no penalties for wind failing to provide the reserve, since current market rules allow no participation of wind in the reserve market. In this context, a reserve penalty for failing to provide reserve market must be assumed. Thus, the reserve penalty for negative reserve imbalance ( $\lambda^{pt-}$ ) is assumed to be three times higher than the capacity price ( $\lambda^{cap}$ ) from the reserve market, since the deficit of reserve in real-time may reduce significantly the proper levels of security and reliability of the system.

Besides the common assumptions for all methodologies used in this work, the PLDR approach requires the definition of breakpoints. Thus, the definition of breakpoints for the PLDR approach follows the same assumptions as the numerical example, i.e., three breakpoints for modelling the piecewise function based on the 25<sup>th</sup>, 50<sup>th</sup> and 75<sup>th</sup> quantile of the wind distribution function for each hour and day are considered.

The cumulative results for energy production and revenue over the two years for each methodology are shown in Table 3. The results depict the cumulative offering bids in day-ahead stage under forecast scenarios. Overall, one can see that the fixed approach offers most of the expected available wind power to the energy market. In contrast, the remaining methods offer the expected available wind power in both markets in a balanced way. i.e., they try improving the expected profit through participating in the reserve market, accounting with a high reserve penalty for failing to provide the contracted reserve. In terms of expected revenue, the flexible approach is the one with higher revenue, followed by the McCormick approach with  $\varepsilon=1$ . The worst expected revenue comes from the fixed approach, presenting a conservative behavior, since it practically only offers in the energy market. Thus, the flexible approach can improve the expected revenue by about 3% over the fixed approach. Additionally, the McCormick approach with  $\varepsilon=0.01$  presents a behavior closer to the fixed approach, as expected. This is due to the parameter  $\varepsilon$  that controls the deviation of the share in the energy and reserve markets between the day-ahead and the balancing stage, which in this case is too restrictive.

Table 3

In contrast, the deployed wind power as energy and reserve and respective revenue is shown in Table 4. The results are based on an evaluation of the offered bids and share from the different approaches under the wind measurement data. Thus, the expected revenue (in Table 4) represents the evaluation of the offered bids (of each approach) under the realization of wind power. The wind measurement data concerns the realization of wind power generation for the two-year data set. Furthermore, the energy and reserve share of the realized wind power have been determined using the share parameter from the second stage problem of each method.

Table 4

One can see that the behavior of the methods under the realization of wind power is similar to the expected results (from Table 3). However, the total amount of realized power is lower than the total expected power (from Table 3), which is also reflected in the energy and reserve share, as well as in the expected revenue. In more detail, the expected revenue under the measurement data of wind power is significantly lower than the expected revenue from the methods under expectation, which makes sense, since deviations of energy and reserve production from day-ahead and balancing take into account the balancing penalties for energy and reserve. It is noteworthy, that the deviation between the expected revenue from the optimization (Table 3) and validation (Table 4) process for each method is 34.30%, 18.36%, 18.25%, 30.07% and 31.96%, respectively.

Nevertheless, the flexible approach is the one with higher expected revenue, while the fixed approach is the method with worst expected revenue. In fact, the difference between the flexible and fixed approach in terms of expected revenue exceeds 22%. Furthermore, it is noteworthy that the decrease of power is higher in the energy share than in the reserve share for most of the methods, which is understandable, since the penalties for energy deviations are considerably lower than the reserve penalty for missing the contracted offer.

## 6. Conclusions

The current participation of the wind power producers in electricity markets will constantly be changing, since wind turbines are now able to provide energy and reserve services in the electricity market.

In this work, four different approaches (fixed and flexible stochastic, under McCormick relaxation and piecewise linear decision rules) for wind power producer's offering in the energy and reserve market are formulated. All the approaches are based on the proportional control paradigm that allocates proportional share of the available wind power to the energy and reserve markets. The fixed stochastic approach shows a risk-averse behavior by fixing the share parameter between the day-ahead and balancing stages. On the opposite direction, the flexible stochastic approach presents a risk-neutral behavior (thereby, increasing the expected revenue), since this approach allows the share parameter assuming different values in both the day-ahead and balancing stages, however, requiring a certain level of perfect information on the balancing stage. On the other hand, piecewise linear decision rules incorporates a more conservative trend by allocating almost all the available wind power to single market participation. This method will always compete with the fixed stochastic approach, since it contemplates robust characteristics, which limits the economic performance of the method. Although, the method is likely to improve by considering better decision of the breakpoints, its improvement will most likely be small, thereby the interest of using piecewise linear decision rules is to some extent limited. In contrast, the stochastic approach with McCormick relaxation gives full degree of freedom to the wind power producers to impose a risk-averse or risk-neutral behavior by just adjusting the coefficient that defines the difference between the share parameter in both the day-ahead and balancing stages. An important conclusion from this work is that all the proposed approaches provide a certain range of solutions that may cover different goals and behaviors of the wind power producer, e.g. maximizing revenue and participation in the energy and reserve market. Thus, the use of such proposed methods can improve

the expected revenue of wind power producers compared to the revenue with current energy-only market participation.

Future work will focus on improving the performance of the piecewise linear decision rules by optimizing the number and value of the breakpoints in the piecewise function. This may be done by studying the version of piecewise linear decision rules with general segmentation.

## References

1. Pinson P, Chevallier C, Kariniotakis GN. Trading wind generation from short-term probabilistic forecasts of wind power. *IEEE Trans Power Syst* 2007;**22**:1148–56. doi:10.1109/TPWRS.2007.901117
2. Usaola J, Moreno MÁ. Optimal bidding of wind energy in intraday markets. In: *6th International Conference on the European Energy Market, EEM 2009*. 2009. 1–7. doi:10.1109/EEM.2009.5207179
3. Morales JM, Conejo AJ, Pérez-ruiz J. Short-term trading for a wind power producer. *IEEE Trans Power Syst* 2010;**25**:554–64.
4. Catalão JPS, Pousinho HMI, Mendes VMF. Optimal offering strategies for wind power producers considering uncertainty and risk. *IEEE Syst J* 2012;**6**:270–7. doi:10.1109/JSYST.2011.2163009
5. Vilim M, Botterud A. Wind power bidding in electricity markets with high wind penetration. *Appl Energy* 2014;**118**:141–55. doi:10.1016/j.apenergy.2013.11.055
6. Dent CJ, Bialek JW, Hobbs BF. Opportunity cost bidding by wind generators in forward markets: analytical results. *IEEE Trans Power Syst* 2011;**26**:1600–8. doi:10.1109/TPWRS.2010.2100412
7. Botterud A, Zhou Z, Wang J, et al. Wind power trading under uncertainty in LMP markets. *IEEE Trans Power Syst* 2012;**27**:894–903. doi:10.1109/TPWRS.2011.2170442
8. Bitar EY, Rajagopal R, Khargonekar PP, et al. Bringing wind energy to market. *IEEE, Trans Power Syst* 2012;**27**:1225–35. doi:10.1109/TPWRS.2012.2183395
9. Zugno M, Jónsson T, Pinson P. Trading wind energy on the basis of probabilistic forecasts both of wind generation and of market quantities. *Wind Energy* 2013;**16**:909–26. doi:10.1002/we
10. Matevosyan J, Söder L. Minimization of imbalance cost trading wind power on the short-term power market. *IEEE Trans Power Syst* 2006;**21**:1396–404. doi:10.1109/TPWRS.2006.879276
11. Zugno M, Morales JM, Pinson P, et al. Pool strategy of a price-maker wind power producer. *IEEE Trans Power Syst* 2013;**28**:3440–50. doi:10.1109/TPWRS.2013.2252633
12. Baringo L, Conejo AJ. Strategic offering for a wind power producer. *IEEE Trans Power Syst* 2013;**28**:4645–54. doi:10.1109/TPWRS.2013.2273276
13. Sharma KC, Bhakar R, Tiwari HP. Strategic bidding for wind power producers in electricity markets. *Energy Convers Manag* 2014;**86**:259–67. doi:10.1016/j.enconman.2014.05.002
14. Dai T, Member S, Qiao W, et al. Optimal bidding strategy of a strategic wind power producer in the short-term market. *IEEE Trans Sustain Energy* 2015;**6**:707–19.
15. Kazempour SJ, Zareipour H. Equilibria in an oligopolistic market with wind power production. *IEEE Trans Power Syst* 2014;**29**:686–97. doi:10.1109/TPWRS.2013.2286094
16. Baringo L, Conejo AJ. Offering strategy of wind-power producer : a multi-stage risk-constrained approach. *IEEE Trans Power Syst* 2016;**31**:1420–9.
17. Ela E, Kirby B, Navid N, et al. Effective ancillary services market designs on high wind power penetration systems. In: *IEEE Power and Energy Society General Meeting*. San Diego, California: 2012. 1–8.
18. Dvorkin Y, Ortega-Vazquez MA, Kirschen DS. Wind generation as a reserve provider. *IET Gener Transm Distrib* 2015;**9**:779–87. doi:10.1049/iet-gtd.2014.0614
19. Michalke G, Hansen AD. Grid support capabilities of wind turbines. In: *Handbook of Wind Power Systems, Springer*. 2014. 569–90. doi:10.1007/978-3-642-41080-2
20. Wang Y, Bayem H, Giralt-Devant M, et al. Methods for assessing available wind primary power reserve. *IEEE Trans Sustain Energy* 2015;**6**:272–80. doi:10.1109/TSTE.2014.2369235
21. Roald L, Misra S, Backhaus S, et al. Optimal power flow with wind power control and limited expected risk of overloads. In: *19th Power systems computation Conf*. Genoa: 2016. 1–7.
22. Shafie-khah M, de la Nieta AAS, Catalão JPS, et al. Optimal self-scheduling of a wind power producer in energy and ancillary services markets using a multi-stage stochastic programming. In: *Smart Grid Conference (SGC)*. 2014. 1–5.
23. Liang J, Grijalva S, Harley RG. Increased wind revenue and system security by trading wind power in energy

- and regulation reserve markets. *IEEE Trans Sustain Energy* 2011;**2**:340–7. doi:10.1109/TSSTE.2011.2111468
24. Soares T, Pinson P, Jensen T V., *et al.* Optimal offering strategies for wind power in energy and primary reserve markets. *IEEE Trans Sustain Energy* 2016;**7**:1–10. doi:10.1109/TSSTE.2016.2516767
  25. Soares T, Pinson P, Morais H. Wind offering in energy and reserve markets. *J Phys Conf Ser* 2016;**749**:12021. doi:10.1088/1742-6596/749/1/012021
  26. Doherty R, O'Malley M. A new approach to quantify reserve demand in systems with significant installed wind capacity. *IEEE Trans Power Syst* 2005;**20**:587–95. doi:10.1109/TPWRS.2005.846206
  27. Raiffa H, Schlaifer R. *Applied statistical decision theory*. 1961.
  28. Morales JM, Conejo AJ, Madsen H, *et al.* Integrating renewables in electricity markets - operational problems. *Springer* 2014;**205**:429.
  29. Drud A. *CONOPT: a system for large scale nonlinear optimization*. ARKI Consulting and Development A/S 1996.
  30. McCormick GP. Computability of global solutions to factorable nonconvex programs: Part I - Convex underestimating problems. *Math Program* 1976;**10**:147–75. doi:10.1007/BF01580665
  31. Georghiou A, Wiesemann W, Kuhn D. Generalized decision rule approximations for stochastic programming via liftings. *Math Program* 2015;**152**:301–38. doi:10.1007/s10107-014-0789-6
  32. Kuhn D, Wiesemann W, Georghiou A. Primal and dual linear decision rules in stochastic and robust optimization. *Math Program* 2011;**130**:177–209. doi:10.1007/s10107-009-0331-4
  33. Warrington J, Goulart P, Mariéthoz S, *et al.* Policy-based reserves for power systems. *IEEE Trans Power Syst* 2013;**28**:4427–37. doi:10.1109/TPWRS.2013.2269804
  34. Zugno M, Morales JM, Madsen H. Robust management of combined heat and power systems via linear decision rules. In: *IEEE International Energy Conference (ENERGYCON)*. Dubrovnik, Croatia: 2014. 479–86. doi:10.1109/ENERGYCON.2014.6850470
  35. Luenberger DG, Ye Y. *Linear and nonlinear programming*. 3rd ed. Int. Ser. Oper. Res. Manag. Sci., New York: : Springer US 2008. doi:10.1017/CBO9781107415324.004
  36. Bukhsh WA, Zhang C, Pinson P. Data for stochastic multiperiod opf problems. <https://sites.google.com/site/datasmpof/>
  37. Pinson P, Madsen H, Nielsen HA, *et al.* From probabilistic forecasts to statistical scenarios of short-term wind power production. *Wind Energy* 2009;**12**:51–62. doi:10.1002/we.284

## Table list

Table 1 – Prices and unit costs for energy and reserve

Table 2 – Expected energy and reserve bids, as well as expected revenue of the simulation for all proposed approaches (fixed, flexible, McCormick and PLDR).

Table 3 – Expected cumulative simulation results of two years of data for all proposed approaches (fixed, flexible, McCormick and PLDR).

Table 4 – Deployed cumulative simulation results of two years of data for all proposed approaches (fixed, flexible, McCormick and PLDR).

**Table 1.** Prices and units costs for energy and reserve

Energy	Price (€MWh)	Reserve	Price(€MW)
$\lambda^{sp}$	40	$\lambda^{cap}$	41
$\lambda^{c,+}$	30	$\lambda^{bpt,+}$	0
$\lambda^{c,-}$	50	$\lambda^{pt,-}$	96



**Table 2.** Expected energy and reserve bids, as well as expected revenue of the simulation for all proposed approaches (fixed, flexible, McCormick and PLDR).

Method	FIXED	Flexible	McCormick ( $\epsilon=1$ )	McCormick ( $\epsilon=0.01$ )	PLDR
Energy bid (MW)	7.84	0.98	1.33	7.13	0.21
Reserve bid (MW)	0	6.86	6.34	0.72	7.33
Total expected power (MW)	7.84	7.84	7.67	7.85	7.54
Expected revenue (€)	305.74	311.75	310.95	306.13	305.92

**Table 3.** Expected cumulative simulation results of two years of data for all proposed approaches (fixed, flexible, McCormick and PLDR).

Method	FIXED	Flexible	McCormick ( $\epsilon=1$ )	McCormick ( $\epsilon=0.01$ )	PLDR
Energy bid (MW)	77 116.14	43 467.19	43 826.89	75 870.59	46 802.13
Reserve bid (MW)	27.14	33 898.43	28 703.61	1 260.12	32 892.09
Total expected power (MW)	77 143.28	77 365.62	72 530.50	77 130.71	79 694.22
Expected revenue (€)	1 905 292.08	1 965 930.58	1 951 840.02	1 907 032.48	1 919 319.43

**Table 4.** Deployed cumulative simulation results of two years of data for all proposed approaches (fixed, flexible, McCormick and PLDR).

Method	FIXED	Flexible	McCormick ( $\epsilon=1$ )	McCormick ( $\epsilon=0.01$ )	PLDR
Energy share (MW)	66 075.92	33 608.11	38 309.53	64 989.56	44 622.15
Reserve share (MW)	21.42	32 489.23	27 787.81	1 107.78	21 475.19
Total expected power (MW)	66 097.34	66 097.34	66 097.34	66 097.34	66 097.34
Expected revenue (€)	1 251 807.04	1 604 984.40	1 595 615.68	1 333 659.36	1 305 892.66