

Planning electricity transmission to accommodate
renewables: Using two-stage programming to evaluate
flexibility and the cost of disregarding uncertainty

Adriaan Hendrik van der Weijde and Benjamin F. Hobbs

January 2011

CWPE 1113 & EPRG 1102

Planning electricity transmission to accommodate renewables: Using two-stage programming to evaluate flexibility and the cost of disregarding uncertainty

EPRG Working Paper 1102

Cambridge Working Paper in Economics 1113

Adriaan Hendrik van der Weijde and Benjamin F. Hobbs

Abstract

We develop a stochastic two-stage optimisation model that captures the multistage nature of electricity transmission planning under uncertainty and apply it to a stylised representation of the Great Britain (GB) network. In our model, a proactive transmission planner makes investment decisions in two time periods, each time followed by a market response. This model allows us to identify robust first-stage investments and estimate the value of information in transmission planning, the costs of ignoring uncertainty, and the value of flexibility. Our results show that ignoring risk has quantifiable economic consequences, and that considering uncertainty explicitly can yield decisions that have lower expected costs than traditional deterministic planning methods. Furthermore, the best plan under a risk-neutral criterion can differ from the best under risk-aversion.

Keywords

Decision making, electricity, transmission, planning, uncertainty

JEL Classification

C61, L94

Contact
Publication
Financial Support

hweijde@feweb.vu.nl
January 2011
Flexnet



Planning electricity transmission to accommodate renewables: Using two-stage programming to evaluate flexibility and the cost of disregarding uncertainty¹

Adriaan Hendrik van der Weijde

Electricity Policy Research Group, University of Cambridge

Department of Spatial Economics, VU Amsterdam

hweijde@feweb.vu.nl

Benjamin F. Hobbs

Electricity Policy Research Group, University of Cambridge

Whiting School of Engineering, The Johns Hopkins University

2 December 2010

1. Introduction

Over the last two decades, the electricity industry has seen several important developments, each of which has impacted transmission planning and increased uncertainty (Shahidehpour, 2004; Thomas et al., 2005). Firstly, many electricity markets previously dominated by a few large vertically integrated utilities have been restructured so that generation investment and operations decisions are made by individual, profit-maximising companies whose power is transmitted on a grid run by an independent system operator. In these markets, transmission and generation decisions are not made simultaneously by the same entity. Planning now has to account for the independent reactions of the generation market in the market (Awad et al., 2010; Tor et al., 2008), which increases uncertainty in transmission planning. .

Secondly, the increasing volume of interregional and international trade in electricity meant that greater amounts of electricity have to be transported further distances (Pollitt, 2009). This not only increases the demand for transmission capacity but also increases the set of uncertainties in transmission planning.

¹ This project was supported by EPSRC Supergen Flexnet funding, with supplemental funding by the US National Science Foundation, EFRI Grant 0835879. We are grateful to Lewis Dale, Cedric De Jonghe, Chris Dent, Richard Green, Daniel Kirschen, David Newbery, Michael Grubb, Michael Pollitt, Duncan Rimmer, Fabien Roques, Goran Strbac, Christian Winzer and an anonymous reviewer for comments on earlier versions of this paper and help with our assumptions. We are particularly grateful to Bert Willems (Univ. Tilburg), for his suggestions which helped us calculate the transmission-only EVPI, to Vladimir Parail (Univ. Cambridge), for sharing his BritNed flow data, to Niall Duncan (Univ. Edinburgh) for generating the hydro output data and to Alex Haffner (National Grid) for supplying the demand data. However, any errors or views expressed are entirely our own responsibility.

Thirdly, concern about climate change has led to increased use of renewable sources of power. The UK and California, for instance, have ambitious goals of meeting a third of their power needs from renewable by 2020. Since renewables are generally more intermittent than conventional generators and are built in different locations, this again increases the amount of uncertainty for transmission planners (California ISO, 2010). Moreover, technological changes over the next two decades could result in very different patterns of renewable development than today.

Until now, with a few exceptions (de la Torre et al., 1999), transmission planners have relied upon deterministic transmission planning models, which are often run several times with different assumptions to assess the robustness of the decision. However, such a robustness analysis may reveal that the optimal transmission plan is highly sensitive to the assumptions, in which case no unambiguous recommendation that can be made; further, even if there are investments that are seemingly optimal under all or most scenarios, they may not constitute the optimally robust plan – i.e., the plan that minimizes expected cost over the range of possibilities. Indeed, we demonstrate this for our case study below.

Therefore, in light of the developments just mentioned, a different modelling framework is necessary. Such a framework would have to satisfy three requirements. Firstly, it should take into account that, in a market with nodal pricing, any transmission planning decisions will change electricity prices and therefore influence decisions made by generators. Secondly, it has to recognize that there is a large amount of uncertainty about future fuel costs, capital costs of new generation capacity, costs of transmission extensions, carbon prices, and government policy. Finally, the framework would have to allow for the fact that decisions can be made now or can be postponed to a time when there might be more certainty, and that decisions made now can change the set of options available later.

There has been some research addressing the first two requirements, in particular on optimal methods for making transmission planning decisions under uncertainty, as well as work that models the game between transmission planners and generators. Surprisingly, relatively little attention has been paid to the third requirement: because decisions can be postponed, the value of the information gained by waiting needs to be compared to the possible costs of delay, and that any decisions made now can change the set of possibilities in the future.

The framework proposed in this paper addresses all of three requirements of transmission planning under uncertainty. Transmission decisions are modelled as a two-stage Stackelberg game. Transmission planners take the first step and commit to certain options, to which the generators react. Subsequently, a wide range of futures could occur. After that, transmission planners can again make decisions, followed by a market response, but the set of alternatives available at this time is constrained by the first-period decisions.

We apply this framework to a stylised representation of the GB transmission system. The resulting model is then used to determine the optimally expansion plan under uncertainty. We compare these results to those that would occur under more traditional planning methods based on deterministic models, robustness analysis based on sensitivity studies, or minimization of maximum regret across scenarios. We also use the model to calculate the expected value of perfect information (EVPI), the cost of making naïve decisions (the expected cost of ignoring uncertainty, ECIU), and the value of being able to postpone decisions until some uncertainty is resolved (the expected cost of ignoring optionality, ECIO). These indices quantify, in different ways, the benefits of considering

uncertainty and flexibility in transmission planning, compared to using simpler deterministic methods. The quantification of EVPI and ECIU using stochastic programming was proposed by Birge and Louveaux (1997), and has been done, for instance, in the case of generation planning under uncertain emissions limitations (Hu and Hobbs, 2010). However, these metrics have not been quantified in the context of transmission planning. They cannot be evaluated quantitatively with a deterministic or one-stage transmission planning model. The stochastic planning framework proposed here will therefore not only result in a more robust and adaptive expansion plan, but it can also be used to quantify the monetary value of using this plan, rather than one obtained from a one-stage or deterministic model.

In the next section, we review the existing literature on the subject. This is followed by a description of our modelling approach in section 3. Section 4 discusses the assumptions and data sources used in our analysis, the results of which are reported in section 5. The results include quantifications of the value of perfect information, the cost of ignoring uncertainty and the cost of ignoring optionality. The final section concludes.

2. Existing literature

Much of the existing literature on transmission expansion planning under uncertainty focuses on one-period investment problems (e.g., Awad et al., 2009; Crousillat et al., 1993; de la Torre et al., 1999; Oloomi Buygi et al., 2004; Oliveira et al., 2007; Hyung Roh et al., 2009; Sauma & Oren, 2006, Sozer et al., 2006; Zhao et al., 2009). Such single-stage models can be used to analyse choices among several transmission alternatives, facing a number of uncertainties about the future. This method generally involves constructing a number of future scenarios. The present value of all future costs, social welfare, or other planning objective is then calculated for each alternative under each scenario. Finally, a decision rule is used to select the best alternative; it is, for instance, the alternative with the smallest expected cost or the lowest maximum regret. The main source of uncertainty in these models is the total generation capacity at each bus or in each zone. This capacity is often taken to be a function of uncertain electricity demand, or simply presumed to have an exogenous probability distribution. Other risks that have been considered by some of these models are unplanned outages of generators and faults in transmission lines. The latter risks are more naturally viewed as high frequency variability within scenarios rather than as distinct scenarios.

This single-stage methodology can be useful to analyse single decisions that have to be taken now and will not influence future electricity generation siting and operations. However, this is often not the case – where and what generation is built will depend in part on local power prices, which in turn depend upon the availability of transmission.

Moreover, the single-stage approach disregards the ability to postpone or alter decisions in the future. Real Options Theory has been applied to transmission expansion planning in an attempt to address this (e.g., Hedman et al., 2005; London Economics, 2003; Fleten et al., 2009; Parail, 2009; Vazquez and Olsina, 2007). In this framework, actions can be taken now, or a ‘real option’ can be taken which allows, but does not oblige, the decision maker to take the action in the future. Simulations are carried out to evaluate future market conditions. Ultimately, the data gathered is used to calculate present values of the different

alternatives in different periods, which can be used in combination with a decision rule to determine the optimal decision strategy.

Although models based on Real Options Theory address some of the fundamental problems with one-period decision models, they still do not accurately reflect some other features of the transmission planning process. Specifically, most do not explicitly model the way transmission decisions influence decisions made by electricity generators. (An exception is Vazquez and Olsina, 2007, who consider how small distributed generators could interact with transmission investment decisions.) This interaction has been further explored by Sauma and Oren (2006). They propose a three-period model, where the network planner acts as a Stackelberg leader and decides on transmission expansion in the first period, the generators invest in new capacity in the second period and the market is operational in the third. However, in Sauma and Oren’s model, there is only one decision stage for the transmission planner and no consideration of later options for adapting transmission plans to developments. Others also proposed models accounting for transmission-generation interactions in deregulated markets, but only considering certainty or just hourly load variations (e.g., Ng et al., 2006; Tor et al., 2008).

Several Transmission System Operators (TSOs) are moving towards a planning process in which transmission expansion is planned under a range of scenarios and optionality is taken into account. A study commissioned by the Spanish TSO (de Dios et al, 2009) solves a deterministic transmission planning model for a number of scenarios, after which it identifies which up-grades are robust across all scenarios, and which upgrades offer flexibility. The California TSO is currently conducting a similar study (California ISO, 2010). It has decided to invest in planning and design studies for lines to several possible wind, geothermal, and solar development areas such that, when the direction of renewable development becomes clearer later this decade, it can act quickly to implement one or more of them.

There are several other strands of literature on transmission expansion planning under uncertainty that do not fall into any of the categories mentioned above. For example, indices of the technical flexibility of electricity networks have been developed in Bresesti et al. (2003) and Capasso et al. (2005). However, there is no existing literature that meets all three requirements mentioned above: modelling gaming between transmission planners and generators, uncertainty, and the possibility of postponing decisions.

3. Model

We propose a stochastic two-stage optimisation model that captures the multistage nature of electricity transmission planning under uncertainty. Although, in later sections, this model is applied to a stylised representation of interregional transmission capacity in the Great Britain (GB) network, the formulation proposed here is general, and can be applied to other networks.

3.1. Notation

Sets	Index
A^1 Transmission investment alternatives available in 2010	a

A^2	Transmission investment alternatives available in 2020 ²	a
G	Generator types	g
G^N	Non-renewable generator types	g
G^R	Renewable generator types	g
G^I	Intermittent generator types	g
H	Model stages	h
I	Regions	i
K	Transmission corridors (each consisting of two non-negative power flows in opposite directions)	k
L	Non-negative power flows between two nodes	l
R	Years	r
S	Scenarios	s
T	Hours	t
T^{SUM}	Summer hours	t

Parameters

Note that there are no scenarios in the first model stage, so for $h=1$ we set $s=0$ for all parameters and variables that are indexed by s .

$CZ_{h,a}^s$	Investment cost of alternative a in stage $h=1,2$, scenario s . Present worth at start of stage [£]
$CX_{h,g}^s$	Cost of new build of generation type g , in stage $h=1,2$, scenario s . Present worth at start of stage, including lifetime operation and maintenance costs [£/MW]
$CY_{h,g}^s$	Variable generation cost for generation type g , in stage $h=2,3$, scenario s [£/MWh]
E_g	Carbon emissions of generation type g [t/MWh]
CP_h^s	Carbon price in stage $h=2,3$, scenario s [£/t]
CC_g	Capacity credit of generation type g
$X_{0,g,i}$	Initial generation capacity 2010, net of announced retirements [MW]
$X_{g,i}^{MAX,s}$	Maximum capacity of generation type g that can be installed at location i in scenario s [MW]
δ_g	Depreciation rate [1/yr] of generator type g
π_s	Probability of scenario s
$W_{g,i,t}$	Output of intermittent generation type g at location i , hour t [MW/MW installed]
$D_{h,i,t}^s$	Electricity demand in stage $h=2,3$, at location i , hour t , in scenario s [MW]
$RT_{h,s}$	Renewables target in stage $h=2,3$, scenario s
i	Interest rate [1/yr]
FOR_g	Forced Outage Rate of generation type g
POR_g	Planned Outage Rate of generation type g

² Note that there are other constraints that limit which options can be chosen in 2020 (e.g., some links can only be built once). We assume that this doesn't depend on the scenario

$F_{0,k}^{MAX}$	Initial maximum flow on corridor k [MW]
$\Delta F_{a,k}$	Increase in transmission capacity of corridor k as a result of transmission investment a [MW]
N	Sample size [number of hours sampled from each year]
RR_g	Ramp rate of generation type g [1/hour]
RC	Reserve capacity rate

Variables

$f_{h,l,t}^s$	Power flow in stage $h=2,3$, scenario s over line l in hour t [MW]
$f_{h,k}^{MAX,s}$	Maximum flow through transmission corridor k in stage $h=2,3$, scenario s [MW]
$z_{h,a}^s$	Transmission investment decision on alternative a in stage $h=1,2$, scenario s (binary variable)
$y_{h,g,i,t}^s$	Generation in stage $h=2,3$, hour t , at location i , generation type g , scenario s [MW]
$\Delta x_{h,g,i}^s$	Type g generation capacity new build in stage $h=1,2$, at location i , scenario s [MW]
tc_h	Total cost in stage h

3.2. Timeline

The first model year, 2010, repeats itself for ten years, as does 2020. The year 2030 is then assumed to repeat itself forever. Each year consists of $52 \times 7 \times 24 = 8736$ hours,³ although, in order to reduce the size of the optimisation problem, a representative sample of size N can be taken. Section 4 below explains this procedure in more detail. At the start of every hour, wind output in each of the seven locations is observed, after which all generators are dispatched accordingly.

At the start of 2010 the transmission operator chooses which investments to undertake during the next decade. All new transmission capacity that results from these investments will become available in the first hour of 2020. Similarly, generators commit to building new generation capacity to come online at the start of 2020. Building times vary, so the start of any actual building project is chosen such that the project will be finished by the start of 2020. Cash flows are discounted accordingly, also taking the construction schedule into account. The second round of investment decisions is made in 2020, with new capacity coming online in 2030. The only decisions made in the third period are those on dispatch. We assume period 3 lasts for 30 years.

³ Our wind output data only covers 8736 hours, which prevents us from using a more conventional total of $365 \times 24 = 8760$ hours. Moreover, for every year to be the same, all years have to start on the same day of the week. To correct for the resulting understatement of energy costs, those costs are multiplied by a ratio of $8760/8736$ in the model.

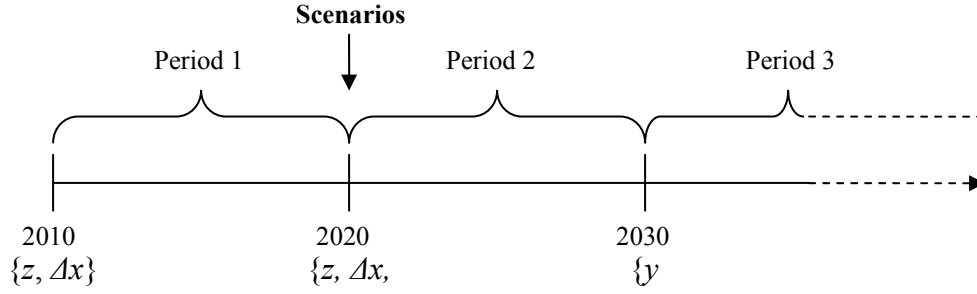

Figure 1 - Model timeline showing sequence of decisions

3.3. Model Objective

We assume perfect alignment of the transmission planner's and generator's objectives, and a perfectly competitive electricity market. This allows us to solve the transmission and generation planning problems in one optimisation model. This model minimises the total expected costs of electricity generation, generation investment and transmission investment, subject to build constraints, capacity constraints, Kirchhoff's laws and renewables targets⁴. The total costs tc_h , $h=1,2,3$ in each model stage h are therefore calculated as follows:

$$tc_1 = \sum_{a \in A1} CZ_{1,a} z_{1,a} + \sum_{g \in G} \sum_{i \in I} CX_{1,g} \Delta x_{1,g,i} \quad (1)$$

$$\begin{aligned} tc_2^s &= \sum_{a \in A2} CZ_{2,a}^s z_{2,a}^s + \sum_{g \in G} \sum_{i \in I} CX_{2,g}^s \Delta x_{2,g,i}^s + \frac{8760}{N} \sum_{r=1}^{10} \left(\frac{1}{1+i} \right)^{r-1} \sum_{g \in G} \sum_{i \in I} \sum_{t \in T} (CY_{2,g}^s + E_g CP_2^s) y_{2,g,i,t}^s \\ &= \sum_{a \in A2} CZ_{2,a}^s z_{2,a}^s + \sum_{g \in G} \sum_{i \in I} CX_{2,g}^s \Delta x_{2,g,i}^s \\ &\quad + \frac{8760}{N} \left[1 - \left(\frac{1}{1+i} \right)^{10} \right] \left(\frac{1+i}{i} \right) \sum_{g \in G} \sum_{i \in I} \sum_{t \in T} (CY_{2,g}^s + E_g CP_2^s) y_{2,g,i,t}^s \end{aligned} \quad (2)$$

$$\begin{aligned} tc_3^s &= \frac{8760}{N} \sum_{r=1}^{30} \left(\frac{1}{1+i} \right)^{r-1} \sum_{g \in G} \sum_{i \in I} \sum_{t \in T} (CY_{2,g}^s + E_g CP_2^s) y_{3,g,i,t}^s \\ &= \frac{8760}{N} \left[1 - \left(\frac{1}{1+i} \right)^{30} \right] \left(\frac{1+i}{i} \right) \sum_{g \in G} \sum_{i \in I} \sum_{t \in T} (CY_{2,g}^s + E_g CP_2^s) y_{3,g,i,t}^s \end{aligned} \quad (3)$$

The objective function then becomes:

⁴ In general, the Stackelberg problem of optimizing transmission networks subject to the equilibrium response of the market is a bi-level problem, in which the equilibrium conditions of the lower level are imposed as constraints on the upper level problem. This mathematical structure is known as a Mathematical Program with Equilibrium Constraints (MPEC). However, if the generation market is efficient and competitive and the TSO's goal is to maximize social surplus (which is consistent with the objective function used to simulate a competitive market), then a single optimization model with the goal of maximizing social surplus can be used (Garcés et al. 2009).

$$\underset{\{z,y,\Delta x,f\}}{MIN} \quad tc_1 + \sum_{s \in S} \pi^s \left[\left(\frac{1}{1+i} \right)^{10} tc_2^s + \left(\frac{1}{1+i} \right)^{20} tc_3^s \right] \quad (4)$$

3.4. Model Constraints

The above objective is optimised subject to the following constraints on the values of the decision variables:

Non-divisibility of transmission alternatives:

$$z_{h,a}^s \in \{0,1\} \quad \forall a \in A^h, h \in \{1,2\} \quad (5)$$

Capacity constraints:

$$\Delta x_{h,g,i}^s \geq 0 \quad \forall s, g, i, h \in \{1,2\} \quad (6)$$

$$X_{0,g,i} (1 - \delta_g)^{10} + \Delta x_{1,g,i} \leq X_{g,i}^{MAX,s} \quad \forall g, i \quad (7)$$

$$X_{0,g,i} (1 - \delta_g)^{20} + \Delta x_{1,g,i} + \Delta x_{2,g,i}^s \leq X_{g,i}^{MAX,s} \quad \forall g, i, s \quad (8)$$

Regional energy balances:

$$\sum_{g \in G} y_{h,g,i,t}^s - D_{h,i}^s + \sum_{l \in L} A_{l,i} [1 - LOSS_l(A_{l,i} / 2 + 0.5)] f_{h,l,t}^s = 0 \quad \forall h, s, i, t \quad (9)$$

where A is a matrix of coefficients $\{-1,0,1\}$, which are -1 when a flow is going out of a region, 1 when it is coming in, and 0 when it is not connecting to the region.⁵

Flow constraints:

$$-f_{h,k}^{MAX,s} \leq \sum_{l \in L} B_{k,l} f_{h,l,t}^s \leq f_{h,k}^{MAX,s} \quad \forall k, h, s, t \quad (10)$$

where B is a matrix of coefficients in $\{-1,0,1\}$, in which two flows that form one corridor have coefficients with opposite signs, and all other flows have a 0 coefficient, and where

$$f_{1,k}^{MAX} = F_{0,k}^{MAX} + \sum_{a \in A} z_{1,a} \Delta F_{a,k} \quad \text{and} \quad f_{2,k}^{MAX,s} = f_{1,k}^{MAX,s} + \sum_{a \in A} z_{2,a}^s \Delta F_{a,k}.$$

A renewables target:

$$\sum_{g \in G^R} \sum_{i \in I} \sum_{t \in T} y_{h,g,i,t}^s \geq RT_h^s \sum_{g \in G} \sum_{t \in T} D_{h,i,t}^s \quad \forall h \in \{2,3\} \quad (11)$$

and a set of binary constraints:

$$\underline{z} \cdot \underline{B} \leq \underline{b} \quad (12)$$

where \underline{z} is a vector of z_a 's, \underline{B} is a matrix of integers in $\{-1,0,1\}$ and \underline{b} a vector of coefficients. These constraints can be used to model the fact that some alternatives can only be chosen in one of the periods and some alternatives in later periods can only be chosen if some action is taken earlier.

Generation constraints for conventional generators:

$$0 \leq y_{2,g,i,t}^s \leq (1 - FOR_g) \left[X_{0,g,i} (1 - \delta_g)^{10} + \Delta x_{1,g,i} \right] \quad \forall s, g \notin G^I, i, t \notin T^{SUM} \quad (13)$$

$$0 \leq y_{3,g,i,t}^s \leq (1 - FOR_g) \left[X_{0,g,i} (1 - \delta_g)^{20} + \Delta x_{1,g,i} + \Delta x_{2,g,i}^s \right] \quad \forall s, g \notin G^I, i, t \notin T^{SUM} \quad (14)$$

⁵ A nonlinear (quadratic) formulation could also be used, and would more accurately represent the relationship between losses and flows (Hobbs et al., 2008). Such a formulation is not included here because of our use of a linear programming framework, which has the advantage of accommodating much larger problems but at the expense of being unable to include explicit nonlinear relationships.

$$0 \leq y_{2,g,i,t}^S \leq (1 - FOR_g)(1 - POR_g) \left[X_{0,g,i} (1 - \delta_g)^{10} + \Delta x_{1,g,i} \right] \quad \forall s, g \notin G^I, i, t \in T^{SUM} \quad (15)$$

$$0 \leq y_{3,g,i,t}^S \leq (1 - FOR_g)(1 - POR_g) \left[X_{0,g,i} (1 - \delta_g)^{20} + \Delta x_{1,g,i} + \Delta x_{2,g,i}^S \right] \quad \forall s, g \notin G^I, i, t \in T^{SUM} \quad (16)$$

Generation constraints for intermittent generators

$$y_{2,g,i,t}^S \leq (1 - FOR_g) W_{g,i,t} \left[X_{0,g,i} (1 - \delta_g)^{10} + \Delta x_{1,g,i} \right] \quad \forall s, g \in G^I, i, t \notin T^{SUM} \quad (17)$$

$$y_{3,g,i,t}^S \leq (1 - FOR_g) W_{g,i,t} \left[X_{0,g,i} (1 - \delta_g)^{20} + \Delta x_{1,g,i} + \Delta x_{2,g,i}^S \right] \quad \forall s, g \in G^I, i, t \notin T^{SUM} \quad (18)$$

$$y_{2,g,i,t}^S \leq (1 - FOR_g)(1 - POR_g) W_{g,i,t} \left[X_{0,g,i} (1 - \delta_g)^{10} + \Delta x_{1,g,i} \right] \quad \forall s, g \in G^I, i, t \in T^{SUM} \quad (19)$$

$$y_{3,g,i,t}^S \leq (1 - FOR_g)(1 - POR_g) W_{g,i,t} \left[X_{0,g,i} (1 - \delta_g)^{20} + \Delta x_{1,g,i} + \Delta x_{2,g,i}^S \right] \quad \forall s, g \in G^I, i, t \in T^{SUM} \quad (20)$$

Reserve capacity constraints:⁶

$$\sum_{i \in I} \left(\sum_{g \in G} (1 - FOR_g) \left[X_{0,g,i} (1 - \delta_g)^{10} + \Delta x_{1,g,i} \right] + \sum_{g \in G^I} (1 - FOR_g) CC_g \left[X_{0,g,i} (1 - \delta_g)^{10} + \Delta x_{1,g,i} \right] \right) \geq (1 + RC) \sum_{i \in I} D_{2,i,t}^S \quad \forall s, t = t^{\max} \quad (21)$$

$$\sum_{i \in I} \left(\sum_{g \in G} (1 - FOR_g) \left[X_{0,g,i} (1 - \delta_g)^{10} + \Delta x_{1,g,i} + \Delta x_{2,g,i}^S \right] + \sum_{g \in G^I} (1 - FOR_g) CC_g \left[X_{0,g,i} (1 - \delta_g)^{10} + \Delta x_{1,g,i} + \Delta x_{2,g,i}^S \right] \right) \geq (1 + RC) \sum_{i \in I} D_{3,i,t}^S \quad \forall s, t = t^{\max} \quad (22)$$

where t^{\max} is the hour where $\sum_{i \in I} D_{2,i,t}^S$ is at its maximum, and CC_g the capacity credit of generation type g , the fraction of the total installed capacity which contributes to system security.

The addition of ramping constraints is also possible with the following constraint, although this constraint will increase computational intensity.

$$(1 - RR_g) y_{h,g,i,t-1}^S \leq y_{h,g,i,t}^S \leq (1 + RR_g) y_{h,g,i,t-1}^S \quad \forall s, g, i, h \in \{2, 3\}, t > 1 \quad (23)$$

This assumes that the hours are ordered chronologically, an assumption not necessary without this constraint.

⁶ More generally, these constraints could be applied to every region individually. For simplicity, this is not done here. If the additional capacity is not or rarely dispatched, and the capital costs of this additional capacity are not significantly different across regions (as is the case in our application), this does not influence the results. A yet more sophisticated representation would account for the fact that, in general, stronger interregional transmission connection lessens total reserve requirements. However, the extent of that effect depends on security requirements, and a rigorous quantification would require probabilistic assessments of contingencies. Therefore, this potential benefit is disregarded in this paper, although it could be addressed in future research.

3.5. Model outputs

The above model is used to calculate the optimally robust transmission- and generation expansion plan, including the optimal dispatch schedules. The cost of this optimal plan is the benchmark against which we can compare solutions to obtain various uncertainty metrics, including the value of information, the cost of ignoring uncertainty and the cost of ignoring optionality. We also compare the expected cost-minimising stochastic solution to solutions that are based on a robustness analysis using sensitivity analysis of a deterministic model, as well as a solution that minimizes the maximum regret across scenarios. The uncertainty metrics are described below; precise mathematical definitions of each are provided in Appendix B.

Expected value of perfect information

First of all, we can calculate by how much the total system costs could be reduced when planners in the first stage knew exactly which scenario would happen in the second stage. The average of these savings across all scenarios is known as the Expected Value of Perfect Information (EVPI). Two versions of the EVPI can be calculated: one where both transmission and generation planners have perfect information about which scenario occurs, and one where only transmission planners do while generation planners consider that all scenarios are possible and so plan accordingly. EVPI will be smaller for just transmission planners than it would be for the entire market.

The EVPI for all market participants is easily calculated using a two-stage model (Birge and Louveaux, 1997; for an electricity application, see Hu and Hobbs, 2010). In addition to solving the stochastic model, using the full set of scenarios, we solve a deterministic model for each scenario, in which the total system costs are minimised for one scenario, while all other scenarios are ignored. The EVPI is then calculated as the difference between a probability-weighted average deterministic cost across all scenarios, and the costs of the stochastic model. The latter necessarily has a higher cost because it has the extra so-called “non-anticipativity” constraint, which specifies that the first stage decisions are the same across all scenarios.

To calculate the transmission-only EVPI, we have to take a different approach. Because in this case, generation planners do not have perfect information and hence minimise their costs using the full set of scenarios, whereas transmission planners do know which scenario will happen, we cannot simply solve a set of deterministic models. We therefore allow transmission decisions $z_{1,a}$ to vary across scenarios, thus changing it to $z_{1,a}^s$ in equations (1)-(4). However, generation investors are still ignorant, not knowing which scenario will take place, so they plan for all scenarios based on the original probabilities. The difference between these costs and the costs of the original stochastic model will be the EVPI when only transmission planners have perfect information. Generation planners act as Stackelberg followers, minimising expected costs across all scenarios, but observing the transmission expansion alternatives committed to by the transmission planner in Stage 1.

The EVPI is useful for at least two reasons. One is that it is a measure of the economic impact of uncertainty, showing how much society or particular market players would be willing to pay to eliminate it. Second, it is an upper bound to the amount that

should be paid for improved forecasts. The evaluation of the precise expected value of particular imperfect forecasting systems is a significantly more complicated undertaking (Clemen, 2001) but is, in theory, possible using stochastic programming methods and should be undertaken in future research.

Expected cost of ignoring uncertainty (ECIU)

The second metric that can be calculated with the above model is the expected cost of ignoring uncertainty (Morgan and Henrion, 1990), which is the same as the value of the stochastic solution (VSS, Birge 1982). Birge and Louveaux (1997) describe how it can be calculated for a two-stage stochastic program, such as ours, and an example of its use in electricity markets is presented in Hu and Hobbs (2010).

The ECIU (VSS) is calculated by first designating one scenario as the “naïve” scenario that market players (or a subset of those players) assume will occur in the future. Then a naïve model is solved in which the chosen scenario will occur with a probability of 1. This is the same as the deterministic models used in the EVPI calculations. Third, the naïve model’s deterministic first-stage decisions are imposed on the full stochastic model, which is then solved for the optimal second stage decisions. This represents a situation in which planners in the first stage naively plan for one specific scenario, even though that scenario is only one of several possible outcomes. In the second stage, the planner recognises which scenario has occurred, and plans future expansions accordingly. Fourth, and finally, ECIU is calculated as the increase in expected cost between the constrained stochastic model (in which first-stage decisions are set equal to their naïve values) and the original unconstrained stochastic model, whose expected cost cannot be higher and is likely to be less because its first stage decisions are not thus constrained.

The ECIU depends critically on the choice of naïve scenario. A planner might conservatively use a worst case scenario, or perhaps only a case based on intermediate values of the forecasted variables. We calculate ECIU here by averaging over the values obtained by designating each of the scenarios in turn as the naïve scenario.

Parallel to the case of the EVPI, in which two different EVPI indices were developed, it is possible to calculate one version of ECIU assuming that both generators and transmission planners are naïve, and another in which only transmission planners are naïve while generators make their first stage decisions assuming the full range of scenarios. The first version is obtained by fixing the first-stage investments at their naïve values in the third step for both generators and transmission. In the second, transmission-only version, the first-stage decisions are set to their naïve values just for transmission, while generators can adjust their first stage investments recognizing the full range of scenarios but that transmission has been planned naively. Here we consider only the second version, focusing on the cost of disregarding uncertainty for just transmission, although it is certainly possible to calculate both versions.

The ECIU is useful to transmission planners because it describes the value (in terms of reduction of expected cost) of considering the full range of uncertainties rather than use a less realistic deterministic planning model. If ECIU is zero, then one may as well use the simpler model; but if it is significant, then the first-stage optimally robust investments must differ from those made by a deterministic model, and implementation of stochastic solution will save costs (in expectation).

Expected cost of ignoring optionality (ECIO)

The final metric we calculate is the cost of ignoring the two-stage nature of the transmission planning problem, which we call the “expected cost of ignoring optionality” (ECIO). This is the value of being able to “wait and see” until it becomes clear which scenario occurs rather than making all decisions “here and now.” This metric represents the additional costs that are incurred if a commitment to a single investment plan in all years has to be made in the first model stage, when there is still a whole range of scenarios that could happen. The plan specifies in an open-loop fashion which investments are made in which years, so in our model, lines can be built in either 2010 or 2020. To calculate this open-loop solution, we solve a version of the stochastic model that imposes a non-anticipativity constraint in 2020:

$$z_{2,a}^s = z_{2,a}^{s-1} \quad \forall a, s \in S \quad (24)$$

The cost of ignoring optionality (the ability to make different “wait-and-see” decisions in different scenarios) is then calculated as the difference between the total system costs in this model, and those in the original stochastic model.

The ECIO index is of interest, because if it is zero, then the simpler one-stage transmission planning models that have previously been proposed can be used to plan. Considering “wait-and-see” decisions that depend on the scenario makes the model larger; however, the ability to adapt a transmission plan according to conditions may have a significant value, and this value is quantified by the ECIO.

4. Assumptions and data

All costs are expressed in real 2010£, unless stated otherwise. Where necessary, cost coefficients based upon earlier years are escalated using the UK Consumer Price Index (Office for National Statistics, 2010). We assume a real discount rate of 5% per year.

4.1. Transmission

Regions and flow definitions

We divide the GB transmission system in seven regions, as shown in figure 2a. These regions are also used by National Grid in their Seven-Year Statement (National Grid, 2009). Each region consists of one or more SYS Study zones, as listed in Table 1. The zones were defined such that a large proportion of transmission congestion occurs at the borders between zones. Note that this approach limits the number of transmission investment alternatives that can be taken into account: transmission upgrades within regions cannot be valued directly. However, this will always be the case as long as the number of regions is limited. Each region is represented by a single node; figure 2b shows a schematic representation of the resulting network, with non-negative flows between all connected regions.

Table 1. Regions and SYS Study Zones

Region	SYS Study Zones
SCO	Z1-Z6
UNO	Z7
NOR	Z8-Z9

MID	Z10-Z11
CEN	Z12-Z14, Z16
SWE	Z17
EST	Z15

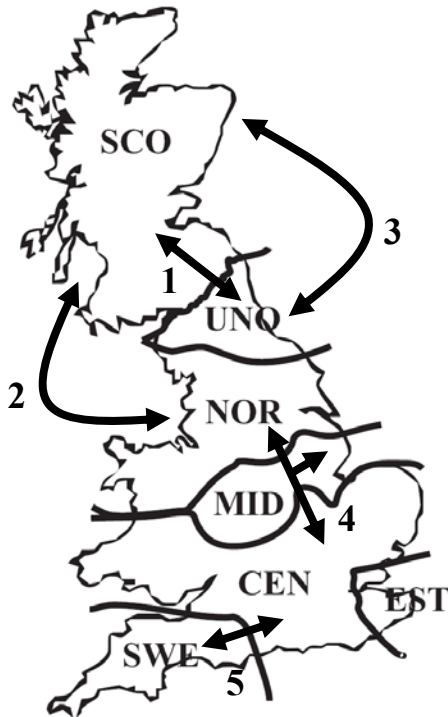

Figure 2a - Regions and expansion alternatives

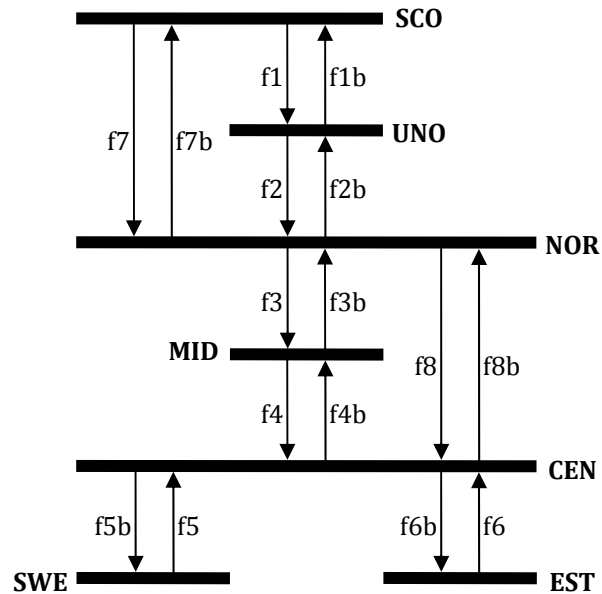

Figure 2b - Flow definitions

Transmission constraints and losses

Transmission constraints are taken from the National Grid Seven Year Statement 2009. They are SYS maximum transfer capabilities at the time of peak demand. If transfers exceed this level, “thermal or voltage limitations become apparent”, and they are therefore taken as maximum flows. We assume constant transmission capacity (for instance, in the absence of seasonal thermal capacity data, we do not allow winter ratings to be higher than summer ratings).

Table 2. Existing flow constraints (excluding new transmission investment) and losses

Corridor	Capacity (MW)	Assumed marginal loss rate (%)
f1 - f1b	2000	1.6
f2 - f2b	3500	1.2
f3 - f3b	11500	1.7
f4 - f4b	12500	3.4
f5 - f5b	2150	1.0
f6 - f6b	5500	0.4
f7 - f7b	0 ^a	4.6
f8 - f8b	0 ^a	2.0

a. Note that these initial maximum flows are zero, as investment is necessary to make them feasible.

Linear loss rates are assumed in order to avoid the complexities of quadratic formulations. Loss rates are based upon typical loss rates for average loading conditions, accounting for the voltages and number of circuits between each region. These values yield loss rates from Scotland to southeast England that are very close to the 8.4% marginal loss rate reported in National Grid (2008).

Transmission expansion alternatives

We consider all transmission expansion alternatives mentioned in ENSG (2009) that cross the regional boundaries defined above. The alternatives listed in the above report are those proposed by the GB TSOs, in cooperation with DECC and Ofgem. The costs and characteristics of the alternatives are taken from the latest available report (KEMA, 2010) and listed below. Note that these costs are discounted to the model stage in which investment is committed to; i.e. to ten years before construction is finished. They consist of the investment costs, the cost of funds during construction, 40 years of (discounted) O&M costs, and costs resulting from outages during construction. O&M costs are assumed to be 0.05% per year of the overnight costs of any new line or upgrade, which corresponds to the percentage SHETL, one of the Scottish TSOs, is allowed to recover through the transmission charge (SSE, 2010). Outage costs for alternatives 1, 2 and 3 are taken from ENSG (2010). Alternative 4 is similar to 2 and 3, in that it is a new HVDC line; hence, its associated outage costs are also assumed to be insignificant. Outage costs for alternative 5 are assumed to be significant, as this alternative includes upgrades of existing AC lines. However, congestion on the boundary it crosses is significantly less severe than congestion on the boundary alternative 1 crosses; therefore, the outage costs will be lower. As reliable sources are not available, we assume these congestion costs will be 1/3 of those for alternative 1.

We consider the following alternatives:

1. Scottish interconnectors: This set of investments, which is always presented as a package, includes installation of series compensation on the SPTL and NGET networks, reconductoring of the Harker-Quernmore circuit, a new underground cable from Torness to Eccles and an upgrade of the northern side of the Strathaven-Wishaw-Kaimes double circuit from 275kV to 400kV. This results in a total of 935MW new transmission capacity across the SCO-UNO system boundary, at a total investment cost (including costs of funds during construction, lifetime O&M costs and costs resulting from outages during construction) of £368M.
2. Western HVDC link: This investment alternative concerns a new offshore HVDC link between Hunterston and Deeside, creating 1530MW of extra capacity across the boundary between regions SCO and NOR, with £626M being its total investment cost.
3. Eastern HVDC: This investment alternative is similar to the previous one, except it connects Scotland with region UNO rather than region NOR. In particular, it concerns a new 1530MW offshore HVDC link between Peterhead and Hawthorn Pit at a total investment cost of £627M.
4. English East Coast – Humberside HVDC: This investment alternative includes a new 1913MW onshore HVDC link from Humberside into East England via Walpole (NOR–CEN) and 850MW expansion of boundary B8 (NOR–MID). Its total investment cost is £447M.

5. South West: This alternative consists of a new 400kV line to the South West, the upgrading of other lines to 400kV, and some substation rebuild and upgrades providing a total of 1750MW extra capacity out of the South West. (SWE-CEN), with a total investment cost of £251M.

Table 3. Transmission investment costs – 2010

Alternative	Overnight construction cost ^a (£M)	Outage Cost ^b (£M)	Lifetime O&M costs (£M, present worth)	CZ (£M) ^c
1	353	120	30.4	368
2	805.3	0	51.8	626
3	828.6	0	51.8	627
4	593	0	37.0	447
5	285.5	40	20.8	251

- a. Undiscounted sum of construction costs in all years. The fractions of costs incurred in each year of construction can be found in KEMA (2010).
b. Incurred one year before construction is finished
c. Includes interest accumulated during construction, outage costs, and present worth of O&M costs, all discounted to 10 years before the in-service date (see text)

4.2. Generation

Generation types, costs and characteristics

Generator efficiencies were taken from NEA and IEA (2005), DOE (2010) and from our own calculations. These were then used, together with the fuel prices listed in Table 3, to calculate the variable costs of generation. Note that these are costs in 2010; the costs in later model stages vary across scenarios. Assumptions about these variations are discussed below.

Capital costs, carbon emissions and lifetime assumptions were also taken from the above sources, as well as from PRIMES (2005), Parliamentary Office of Science and Technology (2006) and Greene & Hammerschlag (2000). Note that the capital costs include construction costs and lifetime operation and maintenance costs, and they are discounted to the year in which the investment decisions are made, i.e., 10 years before construction is completed.⁷ 2005 costs are inflated to 2010 costs using the UK Consumer Price Index (Office for National Statistics, 2010).

Forced outage rates for conventional, distributed and hydro plants are taken from the same sources. Planned outage rates for these plants are taken from EIA (1999), where average yearly outages rates were converted to periodic outages rate through dividing them by 12 and subsequently multiplying them with the number of months that planned

$${}^7 CX_g = \left[1 - \left(\frac{1}{1+i} \right)^{n_g} \right] \left(\frac{i+1}{i} \right) \left(\frac{1}{1+i} \right)^{10} OMC_g + \left[\sum_{k=K-10}^K \left(\frac{1}{1+i} \right)^{k-(K-10)} \gamma_k OC_g \right], \quad (25)$$

where OMC_g is the yearly operation & maintenance cost for generator type g , OC_g its overnight cost not including any allowance for funds used during construction, AFUDC), K the year construction is completed and γ_k the fraction of overnight costs spent in year k . The inclusion of operation and maintenance in the capital costs facilitates the analysis. As long as generators have a fixed lifetime, which cannot be shortened or prolonged, this does not influence the results.

outages are assumed to take place. Outages rates for wind turbines are taken from Harman et al. (2008) and Feng et al. (2010). Again, yearly average outages rates were converted as above.

Table 4. Raw fuel prices - 2010

Fuel	Price	Price (£/MWh)
Coal	50£/tonne	6.56
Gas	0.5£/therm	17.06
Uranium	72.75£/kg	0.52
Biomass	10£/MWh	10.00

Table 5. Operating costs and characteristics - 2010

Plant type	Efficiency	Variable O&M	CY	FOR	POR	CO₂ emissions
	%	£/MWh	£/MWh	%	%	t/MWh
Coal	46.1	3.10	17.33	15.00	13.03	0.748
Gas - combined cycle	59.1	1.35	30.22	15.00	7.03	0.353
Gas - open cycle	32.0	2.14	55.45	15.00	7.03	0.530
Nuclear	36.1	0.34	1.79	15.00	10.46	0.000
Biomass	38.0	4.53	30.85	17.00	8.57	0.093
Distributed generation	38.0	4.80	49.70	17.00	8.57	0.540
Hydro	n/a	1.64	1.64	5.00	8.57	0.000
Onshore Wind 1	n/a	0	0	1.80	1.20	0.000
Onshore Wind 2	n/a	0	0	1.80	1.20	0.000
Onshore Wind 3	n/a	0	0	1.80	1.20	0.000
Offshore Wind	n/a	0	0	3.80	1.20	0.000

Table 6. Investment costs and lifetime - 2010

Plant type	Overnight costs	Overnight costs + AFUDC, discounted ten years	Fixed O&M	Lifetime	CX
	£/kW	£/kW	£/kW/year	years	£/kW
Coal	-	-	-	40	-
Gas - combined cycle	505	343	28.60	30	627
Gas - open cycle	390	258	26.59	30	521
Nuclear	2583	1889	33.95	50	2289
Biomass	1432	974	40.08	30	1371
Distributed generation	811	536	28.60	25	795
Hydro	3608	2444	28.86	25	2706
Onshore Wind 1	964	637	28.48	25	896
Onshore Wind 2	1205	796	28.48	25	1055
Onshore Wind 3	1446	955	28.48	25	1214
Offshore Wind	1989	1314	48.96	25	1759

Although the existing coal generation capacity can be used, no new capacity can be built. We do not consider coal plant with carbon capture and storage (CCS) as, based on existing estimates of its costs (IPCC, 2005), including the costs of storage and increases in fuel consumption, it will not be competitive enough to capture a significant market share by 2030. Other types of plant, such as those using solar, wave or tidal energy, are also

excluded, for the same reasons. Of course, significant reductions in the costs of carbon capture and storage or solar, wave and other types of plant could change this. Further research should address this.

All types of wind turbines, hydro and biomass plants are considered to be renewable, and only power generated by these types of generators can count towards a renewables target. Only wind and hydro are intermittent.

Existing generation capacity and maximum newbuild

This data was taken from the 2009 DUKES (DECC, 2009), which includes all power plants with an installed capacity greater than 1MW. These plants were then sorted into the seven regions using their post codes. If plants could be co-fired, only their main fuel was taken into account, and if no information was available on what their main fuel was, the first mentioned fuel was used. Oil- and coal-fired plant that is scheduled to be closed before 2020 to comply with the EU Large Combustion Plant Directive (LCPD) was removed from the dataset. Similarly, nuclear plants that are scheduled to be closed before 2020 were removed, with only Torness, Hartlepool, Heysham 1 and 2, and Sizewell B remaining. CCGT plants currently under construction were added.

For on- and offshore wind farms, the list in the 2009 DUKES proved to be outdated. The RenewableUK (formerly BWEA) UK Wind Energy Database (UKWED) was therefore used instead. Again, wind farms were sorted into regions using their post codes, and only farms with an installed capacity greater than 1MW were considered. Wind farms currently under construction were included.

Assumptions on maximum capacities in 2020 and 2030 were compiled from various sources. The maximum installed onshore wind capacity was taken from Garad Hassan (2001). Because a similar study was not available for regions in England and Wales, we used the Scottish maximum capacities, scaling them down proportionate to the size of each region. The maximum offshore wind capacity in 2020 was calculated as the sum of the maximum capacities in the round 1, 2 and 3 tenders, as well as the proposed sites in the Scottish territorial waters. The maximum offshore wind capacity in 2030 is assumed to be 20GW in each English/Welsh region and 25GW in Scotland.

The potential for biomass plant is assumed to be limited to 4GW, with a maximum of 1GW in each region, because the biomass is usually grown in close proximity to the power plant. Similarly, since most of the suitable sites for hydroelectric power plants have already been exploited, the potential for new hydro is assumed to be limited, and zero in EST and SWE.

We assume that, in the scenarios where nuclear newbuild is possible, a maximum of 3GW can be built before 2020, which is in line with the scenarios National Grid uses in its planning studies. In 2030, the installed capacity is limited to 40GW, with a maximum of 20GW in each region. Gas turbines of both types can be built in large numbers, up to 20GW in each region.

Table 7. Existing generation capacity – 2010 (MW)

Plant type	SCO	UNO	NOR	MID	CEN	SWE	EST	Total
Coal	2304	0	8512	7026	1913	0	0	19755
CCGT	123	1875	10538	4394	9814	890	2220	29854
OCGT	1540	0	210	124	715	63	167	2819
Nuclear	1205	1190	2400	0	1188	0	0	5983
Onshore Wind 1	2507	120	491	119	348	47	60	3691
Onshore Wind 2	0	0	0	0	0	0	0	0
Onshore Wind 3	0	0	0	0	0	0	0	0
Offshore Wind	190	4	330	194	879	0	563	2160
Hydro	1296	6	120	0	0	0	0	1422
Biomass	56	0	311	0	158	0	0	525
DG	0	0	0	0	0	0	0	0
Total	9221	3195	22912	11857	15015	1000	3010	66210

Table 8. Maximum installed generation capacity – 2020 (MW)

Plant type	SCO	UNO	NOR	MID	CEN	SWE	EST	Total max
Coal	–	–	–	–	–	–	–	–
CCGT	20000	20000	20000	20000	20000	20000	20000	–
OCGT	20000	20000	20000	20000	20000	20000	20000	–
Nuclear	4205	4190	5400	3000	4188	3000	3000	8983
Onshore Wind 1	3833	714	1798	978	2829	872	291	–
Onshore Wind 2	3833	714	1798	978	2829	872	291	–
Onshore Wind 3	3833	714	1798	978	2829	872	291	–
Offshore Wind	11063	484	19957	464	14124	0	1894	–
Hydro	1500	500	500	500	500	0	0	–
Biomass	1000	1000	1000	1000	1000	1000	1000	4000
DG	5000	5000	5000	5000	5000	5000	5000	–

Table 9. Maximum installed generation capacity – 2030 (MW)

Plant type	SCO	UNO	NOR	MID	CEN	SWE	EST	Total max
Coal	–	–	–	–	–	–	–	–
CCGT	20000	20000	20000	20000	20000	20000	20000	–
OCGT	20000	20000	20000	20000	20000	20000	20000	–
Nuclear	20000	20000	20000	20000	20000	20000	20000	40000
Onshore Wind 1	3833	714	1798	978	2829	872	291	–
Onshore Wind 2	3833	714	1798	978	2829	872	291	–
Onshore Wind 3	3833	714	1798	978	2829	872	291	–
Offshore Wind	25000	20000	20000	20000	20000	20000	20000	–
Hydro	1500	500	500	500	500	0	0	–
Biomass	1000	1000	1000	1000	1000	1000	1000	4000
DG	5000	5000	5000	5000	5000	5000	5000	–

Wind output

We use hourly 1995 regional wind output data from Neuhoff et al. (2007), which is created by converting average regional wind speeds to output using the power curve of a Nordex N80 turbine. We have no reason to assume that wind speeds in the 2010–2030 timeframe will be significantly different from those in 1995, as the average wind speed in 1995 does

not appear to be significantly different from the long-time average (Sinden, 2007). However, we recognize that the average and pattern of wind can vary from year-to-year, and future work should attempt to include a distribution of wind that reflects the distribution of conditions over several years. The robustness of the data is further discussed in Neuhoff et al. (2006). As figure 3 shows, there is a significant difference in wind capacity factors among the seven regions: on average, a 1MW turbine in Scotland produces almost twice as much electricity as a similar turbine in the Midlands.

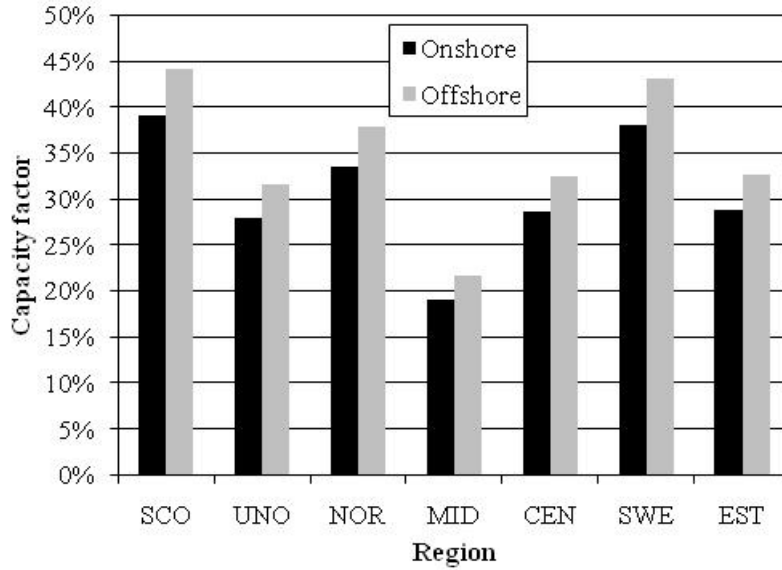

Figure 3 - Capacity factor of wind turbines in all regions

Neuhoff et al. only consider onshore wind farms. We generate regional hourly offshore wind output data according to the following formula:

$$W_{offshore,i,t} = \left\{ \begin{array}{l} W_{onshore,i,t} + \alpha_i \text{ if } W_{onshore,i,t} > 0 \\ (W_{onshore,i,\tau} + \alpha_i) \left[1 - \frac{\ln(|t - \tau|)}{3} \right] \text{ if } W_{onshore,i,t} = 0 \text{ and } \tau \leq 4 \\ 0 \text{ if } W_{onshore,i,t} = 0 \text{ and } \tau > 4 \end{array} \right\} \quad (26)$$

where τ is the hour nearest in time to t when $W_{offshore,i,t} > 0$. If τ is not unique (i.e., in the third hour of a five-hour period where onshore wind does not produce any output),

$$W_{onshore,i,\tau} = \frac{W_{onshore,i,\tau_1} + W_{onshore,i,\tau_2}}{2}, \quad (27)$$

where τ_1 and τ_2 are nearest hours before and after t for which $W_{offshore,i,t} > 0$. For every region, α_i is chosen such that

$$\sum_t W_{offshore,i,t} = 1.13 \sum_t W_{onshore,i,t} \quad (28)$$

to correspond to the 13% average difference in load factors reported in the 2009 Digest of UK Energy Statistics (DUKES, 2009)

This particular transformation is chosen to reflect the fact that offshore wind turbines have higher average load factors and also produce electricity during more hours. The negative logarithmic function results in load duration curves similar in form to those in the offshore wind literature (e.g. Sørensen, 2004). As an example, figure 4 shows the result of the transformation for wind output in SCO.

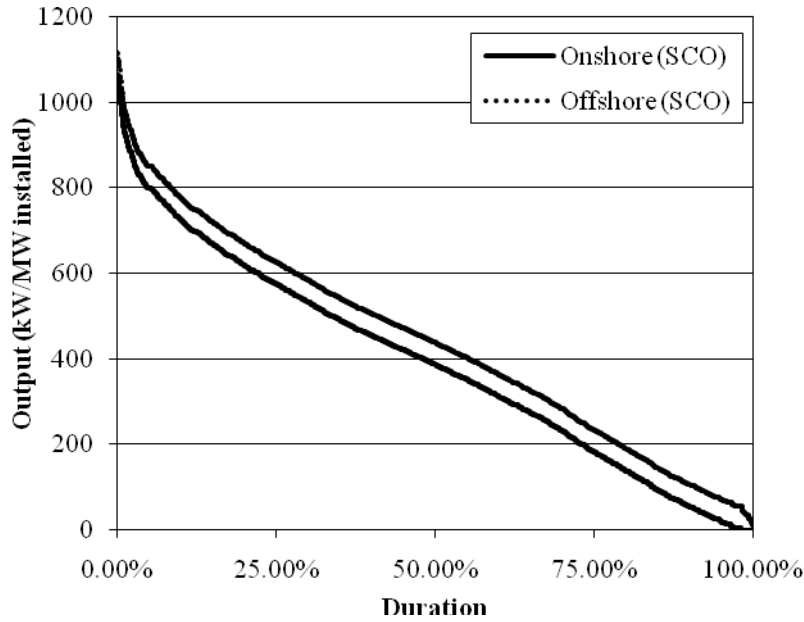

Figure 4 - Wind output duration curve for onshore and offshore wind in SCO

Hydro output

We use hourly hydro output data from Duncan (2010), who models a hypothetical run-of-river scheme located in the Glenmeannie catchment in the North of Scotland, using simulated flows produced by a hydrological model for 1961-2005. The scheme utilises a single Francis turbine and has a mean flow of 5.97 m³/s (the maximum flow the turbine can use) and a gross head of 100m, which is a typical size, giving a max output rating of 4976 kW, accounting for hydraulic losses and efficiency of the Francis turbine. To account for generator and transformer efficiency and local transmission losses, we reduce the output by 5% in all hours.

This data was used to calculate hourly load factors, which were aggregated across all years and across all days in a month, resulting in twelve monthly averages. These averages were then used to construct one year of hourly output data, which was generated by drawing random numbers from a normal distribution with the calculated monthly average as mean, and a standard error of 0.2. The final dataset was constructed by changing these hourly load factors to zero if they were negative, and to one if greater than one. The standard error was chosen such that the hydro output was similar to a representative month of the original data, including a number of hours with zero output and a number of hours with maximum output.

Other assumptions

We do not include ramping constraints in the analysis presented below, as they result in an additional computational burden, and are usually thought to have limited effects in long-term planning models. Moreover, the sampling process we use is not compatible with the use of ramping constraints, as it samples individual hours, rather than larger periods. Changing to the latter, while keeping the sample size constant, would result in a sample with moments and correlations further away from those of the population. To verify that the exclusion of ramping constraints had no influence on the results, we included them in one model run, without changing the sample. Even though this approach overstates the influence of ramping constraints, the optimal transmission expansion plan did not change.

We assume that new generation capacity built in 2010 and 2020 will last at least until the end of the timeframe modelled; it does not depreciate. Generation capacity that exists at the start of 2010 is assumed to depreciate at a constant yearly depreciation rate δ_g , where δ_g is the inverse of the generator's lifetime.

The capacity reserve margin, RR, is assumed to be 5% over peak demand. Planned maintenance is assumed to take place from April to October. To calculate the capacity credit of the renewable power sources, CC_g , we take the 20% peak demand hours, and in those hours, the nation-wide average resource availability during the 5% of hours with the lowest resource availability. This results in a capacity credit of 7.08% for onshore wind, 10.79% for offshore wind and 22.14% for hydro, not including any adjustments for forced outages. These figures are in line with those quoted in the existing literature (e.g. Bartels et al., 2006).

4.3. Demand

We obtained one year of half-hourly demand data at Grid Supply Points, aggregated for each of the SYS study zones, from National Grid. The data stretches from April 2009 to March 2010; to align it with the wind and hydro data, we moved April-December 2009 to the end of the dataserie, thus creating one calendar year of data. The half-hourly data was then aggregated to hourly data, and SYS study zones were aggregated to our seven regions.

Data on the electricity use of pumped storage was taken from the National Grid website (insert reference). We assume that each day at 9 a.m, 70% of the energy used for pumping in the previous night is available to meet demand. This corresponds to the efficiency of the UK's largest pumped storage facility, Dinorwig Power Station in Gwynedd, North Wales (First Hydro Company, 2010). From 9am to 11pm, 1/15 of this energy is subtracted from demand in every hour. This is allocated to the individual regions using the shares of pumped storage installed in each region as a part of the total amount of pumped storage installed (24% in SCO and 76% in NOR).

From the National Grid website (National Grid, 2010), hourly data on power flows on the Moyle interconnector and the interconnector to France were collected; these were subtracted from demand in SCO and EST, respectively. In 2020, the first year in which dispatch is calculated in our model, the BritNed interconnector will also be operational. We used hourly data on expected BritNed flows from Parail (2010), and subtract them from demand in EST. The result is one year of hourly demand data for each of our seven regions, net of imports/exports and net of generation by pumped storage facilities. Table 10 lists some statistical properties of the flows on the interconnectors.

Table 10. Interconnector flow statistics

Interconnector	Min	Max	Mean	Stdev
Moyle (IE-UK)	-464	81	-261	137
France (FR-UK)	-2022	1985	127	1383
BritNed (NL-UK)	-1000	1000	-258	939

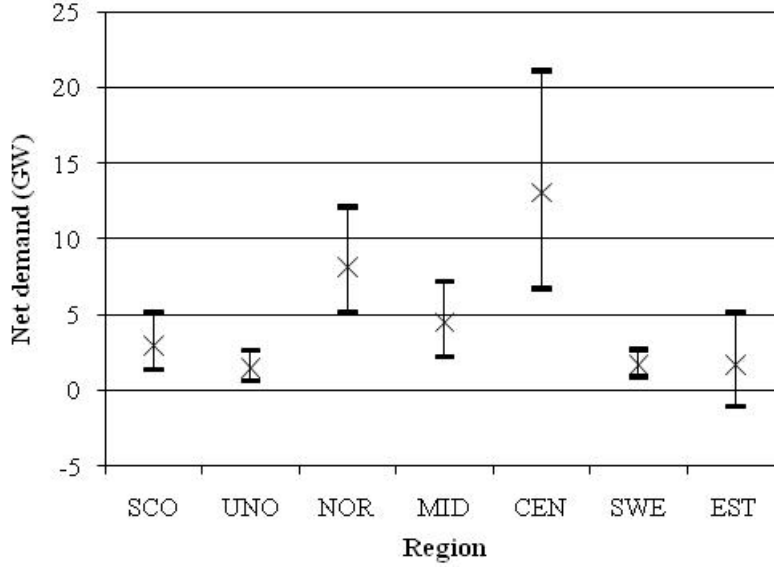

Figure 5 - Net demand averages and ranges

Sampling

Using a full set of 8736 hours⁸ in every model period would result in a model with several millions of variables and constraints, which is too large to solve. We therefore sample 500 hours. To ensure that the sample preserves the original correlations between wind output and demand in the seven regions, as well as the means and standard deviations of wind output and demand, we take 10,000 samples of 500 hours, and choose the sample whose statistical properties most closely match the original full data set of 8736 hours. In particular, we choose the sample that minimises

$$\sum_{i \in I} \sum_{j \in I} \left[(ddcorr_{i,j} - \overline{ddcorr_{i,j}})^2 + (dwcrr_{i,j} - \overline{dwcrr_{i,j}})^2 + (wwcorr_{i,j} - \overline{wwcorr_{i,j}})^2 \right] + \sum_{i \in I} \left[(dmean_i - \overline{dmean_i})^2 + (wmean_i - \overline{wmean_i})^2 + (dsd_i - \overline{dsd_i})^2 + (wsd_i - \overline{wsd_i})^2 \right] \quad (27)$$

where $ddcorr_{i,j}$ is the correlation between demand in regions i and j , $dwcrr_{i,j}$ the correlation between demand in region i and wind output in region j , $wwcorr_{i,j}$ the correlation between wind output in regions i and j , $dmean_i$ the average demand in region i , $wmean_i$ the average wind output in region i , dsd_i the standard deviation of demand in

⁸ Not 8760, for reasons explained above.

region i and wsd_i the standard deviation of wind output in region i . Bars above parameters indicate that they apply to the sample of 500 hours only. The exact values of these correlations, means and standard deviations for both the full dataset and the sample are listed in appendix A.

4.4. Scenarios

We developed six scenarios, which are broadly in line with existing sets of scenarios, such as those developed by Redpoint (2007), Ofgem (2008, 2009) and Elders et al. (2008). None of these sets of scenarios could be used directly, as they are all developed for different types of models where, for instance, future installed generation capacity is an exogenous parameter in each scenario, rather than a variable representing the equilibrium response of the generation market. However, our scenarios are intended to span the same approximate range of possible future developments regarding fundamental technological, economic, and policy drivers.

The six scenarios capture several different effects. First of all, the levels of several model parameters, such as future generation costs and demand levels, are different across scenarios. Given their probabilities, the means and ranges of these parameters can be calculated. Moreover, the scenarios also capture the correlations between the parameters. Since there are only six scenarios, and many parameters, not all correlations are represented, but it is difficult to increase the number of scenarios, for computational reasons. As a base case, we assume the scenarios have equal probabilities; $\pi^s = 1/6$ for all s .

In the first scenario, '*Status Quo*', there are no major changes to any of the variables that influence transmission and generation planning. Demand grows very slowly, and, although gas prices increase, resulting in a moderate increase in operating costs of gas-fired power plants, capital costs of all power plants remain at their current level.

The carbon price remains at the current, low, level and no renewables target is enforced. The second scenario, '*Low Cost DG*', is a scenario where distributed generation is more attractive. Gas prices have decreased, and technological advances have lowered the capital costs of distributed generation significantly. Carbon prices are twice as high as in the previous scenario, a moderate renewables target is enforced and only existing nuclear power plants can be replaced; no nuclear newbuild is allowed.

The '*Low Cost Large Scale Green*' scenario, on the other hand, features conditions that are likely to favour more large scale renewables. Gas prices increase significantly, an ambitious renewables target is enforced and the carbon price is high. On the demand side, energy efficiency measures, coupled with the fact that energy-intensive industries leave the country, lead to a significantly lower demand.

'*Low Cost Conventional*' is the opposite of this scenario. A simultaneous decrease in the gas price and the capital costs of new conventional plant, together with a moderate demand growth, low carbon price and the absence of a renewables target create a favourable environment for conventional plant.

In the '*Paralysis*' scenario, a change in public opinion not only prevents the new build of nuclear plants, it also makes the construction of other types of onshore generation capacity, as well as transmission, much more expensive. Even though demand growth and the carbon price are both moderate, this is the 'worst case'-scenario, in which building anything is very difficult.

Finally, 'Techno+' is a scenario in which technological progress decreases the costs of all new construction projects, of generation as well as transmission. This scenario also features a moderate demand growth, a moderate carbon price and a moderate renewables target.

Table 11. 2020 scenarios

Scenario	Operating costs CY (change from 2010)	Capital costs CX (change from 2010)	Transmission investment costs CZ (change from 2010)	Demand (change from 2010)	Carbon price (£/tonne)	Renewables target (% of total electricity production)	Nuclear newbuild
Status Quo	CCGT/OCGT/DG +30%			2.5%	15	None enforced	
Low Cost DG	CCGT/OCGT -10%, DG -50%	DG -30%		2.5%	30	10%	Replacement only ^a
Low Cost Large Scale Green	CCGT/OCGT/DG +60%	Renewables -30%		-10%	50	30%	
Low Cost Conventional	CCGT/OCGT/DG -10%	Conventional -20%		10%	20	None enforced	
Paralysis	CCGT/OCGT/DG +30%	All except offshore +100%	+100%	10%	30	10%	Replacement only ^a
Techno+	CCGT/OCGT/DG +30%	All -20%	-20%	10%	30	20%	

a. In this scenario, the total amount of nuclear capacity installed in 2020 cannot exceed the installed capacity in 2010

Table 12. 2030 scenarios

Scenario	CY (change from 2010)	CX (change from 2010)	Demand (change from 2010)	Carbon price (£/tonne)	Renewables target (% of total electricity production)	Nuclear newbuild
Status Quo	CCGT/OCGT/DG +80%		5%	15	None enforced	
Low Cost DG	CCGT/OCGT -20%, DG -50%	DG -30%	5%	50	20%	Replacement only ^a
Low Cost Large Scale Green	CCGT/OCGT/DG +160%	Renewables -30%	-20%	80	40%	
Low Cost Conventional	CCGT/OCGT/DG -20%	Conventional -20%	20%	25	None enforced	
Paralysis	CCGT/OCGT/DG +80%	All except offshore +100%	20%	50	20%	Replacement only ^a
Techno+	CCGT/OCGT/DG +80%	All -20%	20%	50	30%	

a. In this scenario, the total amount of nuclear capacity installed in 2030 cannot exceed the installed capacity in 2020

5. Results

Based on the assumptions summarized above, we solve the model outlined in section 3 as a Mixed-Integer Program (MIP) in AIMMS 3.9, using Gurobi 2.0.1. The model has approximately 500K decision variables and a similar number of constraints. Several sets of results are summarised here. We first report the optimal stochastic solution, which we then compare to the more traditional robustness analysis. This is followed by analyses of the EVPI, ECIU and ECIO. Finally, we report the results of a regret analysis and an analysis the implications of risk-aversion.

5.1. Optimal stochastic solution

An optimal stochastic solution consists of the expected cost-minimising strategy of a single first stage (“here-and-now”) set of investments that applies to all scenarios, as well as six sets of later second stage (“wait-and-see”) investments and operation decisions, one set per scenario. In the stochastic solution, the Eastern and Western HVDC projects, connecting Scotland to England, are built in the first stage to increase the transmission capacity to/from Scotland. Only if offshore wind becomes less expensive relative to other plant types (i.e., in the Paralysis scenario, where other kinds of generation become much more costly or even infeasible), are the existing interconnector to Scotland and the connection to the South West upgraded in the second stage to accommodate the resulting large investments in wind. In all other scenarios, there is no second-stage transmission investment. Tables 13 and 14 show the generation investments undertaken in the two model periods. They show that more offshore wind is built in the Paralysis scenario than in the other scenarios because nuclear new build, other than the replacement of existing plants, is not allowed, and the costs of offshore wind turbines have decreased relative to the cost of other plant types.

There are several explanations for this pattern of more transmission investment in the first stage. Firstly, it could result from the ten year lead time of transmission and generation expansion projects. Because of the long time between investment decisions and operation of new lines and plants, decisions in 2010 have to be taken in anticipation of all possible scenarios for 2020. Specifically, if at least one of these scenarios includes a binding renewables target, the building of new renewable capacity has to start in 2010, because starting in 2020 will be too late. Since the most attractive renewable resource that can be built on a large scale, strong wind, is mainly available in Scotland, this also means that the transmission capacity needed to transport the output of Scottish wind turbines southwards also has to be built between 2010 and 2020. Similarly, if at least one scenario includes high demand growth in 2020, the building of new generation capacity (including reserve capacity in the form of open-cycle gas turbines, as table 3 shows) will have to start much earlier, even though that scenario is not necessarily likely to occur. Hence, generation capacity, and the transmission capacity needed to transport the electricity generated by that capacity, has to be built to satisfy all constraints in the most extreme scenarios. This, together with relatively low demand growth rates after 2020, provides a strong incentive for investment earlier rather than later. However, as section 5.2 shows, this cannot be the main explanation.

Secondly, and most importantly, it may be optimal to invest early in transmission expansion projects that are likely to be built anyway. That way, the benefits can be

obtained as early as possible, including investment and operation of more economical power plants, reducing the costs of generation.

Finally, although transmission investments in 2020 are discounted ten years, thus reducing their present discounted value, part of this is offset by an increase in the expected price of new transmission lines. On average, across scenarios, the overnight cost of transmission in 2020 is 2/15 more expensive than in 2010.

To some extent, the emphasis on first-stage investment is the result of end effects. If a third, later decision stage for transmission investment was modelled, with additional scenarios, this might change the results somewhat. However, such a model would be several times as large as the present model, which already stretches the capability of the solver and hardware available to us, so determination of whether the high level of first-stage investment is an artefact of the use of two rather than more stages will need to be the subject of future research.

Table 13. Generation investment 2010 (MW), stochastic solution

Region	Onshore wind	Biomass	Nuclear	CCGT	OCGT
SCO	8724	-	-	-	316
UNO	1348	1000	293	2234	4609
NOR	5067	-	-	-	-
CEN	4518	887	3217	-	3082
SWE	2586	814	-	-	1710
EST	542	925	584	-	1532

Table 14. Generation investment 2020 (MW), stochastic solution

Scenario	Onshore wind	Offshore wind	Biomass	Nuclear	CCGT	OCGT
Status Quo	-	-	-	UNO: 3414 CEN: 9216 SWE: 952 EST: 264	-	-
Low Cost DG	-	SCO: 284 UNO: 27 NOR: 109 CEN: 78 SWE: 11 EST: 13	-	SCO: 180 UNO: 178 NOR: 359 CEN: 178	UNO: 1715 CEN: 4971 SWE: 606	-
Low Cost Large Scale Green	-	SCO: 675 NOR: 109 CEN: 78 SWE: 11 EST: 13	MID: 108	UNO: 2738 MID: 1733 CEN: 7146 SWE: 513	-	-
Low Cost Conventional	-	-	-	UNO: 5794 MID: 3820 CEN: 10278 SWE: 1036 EST: 190	-	-

Paralysis	-	SCO: 3411 NOR: 15746 SWE: 3718	CEN: 32 EST: 75	SCO: 180 UNO: 178 NOR: 359 CEN: 178	UNO: 3032 CEN: 2277 SWE: 424	CEN: 7122 EST: 845
Techno+	SCO: 1668 UNO: 27 NOR: 109 CEN: 986 SWE: 11 EST: 304	SCO: 612 SWE: 414	CEN: 32 EST: 75	UNO: 7578 MID: 2829 CEN: 14180 SWE: 856 EST: 65	-	-

Tables 15 and Fig. 6 show how these plants are used in each second-stage scenario. Table 15 lists the average load factors of all types of plants, from which several interesting conclusions can be drawn. Firstly, OCGT plants are almost exclusively used as reserve capacity. This is because, although they have a high variable cost, this is not relevant, as most of them will never be used. Their low fixed costs therefore make them very attractive. Secondly, the load factors can vary significantly across scenarios; for instance, much less coal plant is used in the Low Cost DG scenario than in any other. This shows that different carbon prices, renewable targets and demand growth can significantly change the UK generation mix. Finally, although offshore wind turbines can produce more power than onshore wind turbines, they have lower average load factors. However, this is arbitrary, as both types of turbines have zero variable costs. When wind has to be spilled, as is the case, the model will dispatch onshore and offshore wind randomly, up to the export constraint. Fig. 6 shows the load duration curve for one of the scenarios. The plant merit order is clearly visible; nuclear plants are used as base load, and run continuously throughout the year. Coal plants are also used for most of the year, except in periods with a very low load net of wind and hydro output. Biomass and CCGT plant is operated as mid-load plant, while open cycle turbines are used as peaking capacity. The bands are not completely smooth, for several reasons. Firstly, hours are sorted by their net load, so summer and winter hours, in which plants have different availability rates, are mixed. Secondly, if wind output is high, conventional generators in export-constrained regions will not be able to export their power. Hence, their feasible production varies from hour to hour.

Table 15. Average load factors in 2020 ⁹

Scenario	Onshore Wind	Offshore Wind	Hydro	Biomass	Nuclear	Coal	CCGT	OCGT
Status Quo	0.31	0.34	0.48	0.55	0.82	0.76	0.15	0.0025
Low Cost DG	0.31	0.34	0.48	0.80	0.82	0.07	0.55	0.0025
Low Cost Large Scale Green	0.31	0.34	0.47	0.78	0.81	0.56	0.06	0.0001
Low Cost Conventional	0.31	0.34	0.48	0.73	0.82	0.73	0.23	0.0071
Paralysis	0.31	0.34	0.48	0.80	0.82	0.74	0.22	0.0071
Techno+	0.31	0.34	0.48	0.80	0.82	0.74	0.22	0.0071

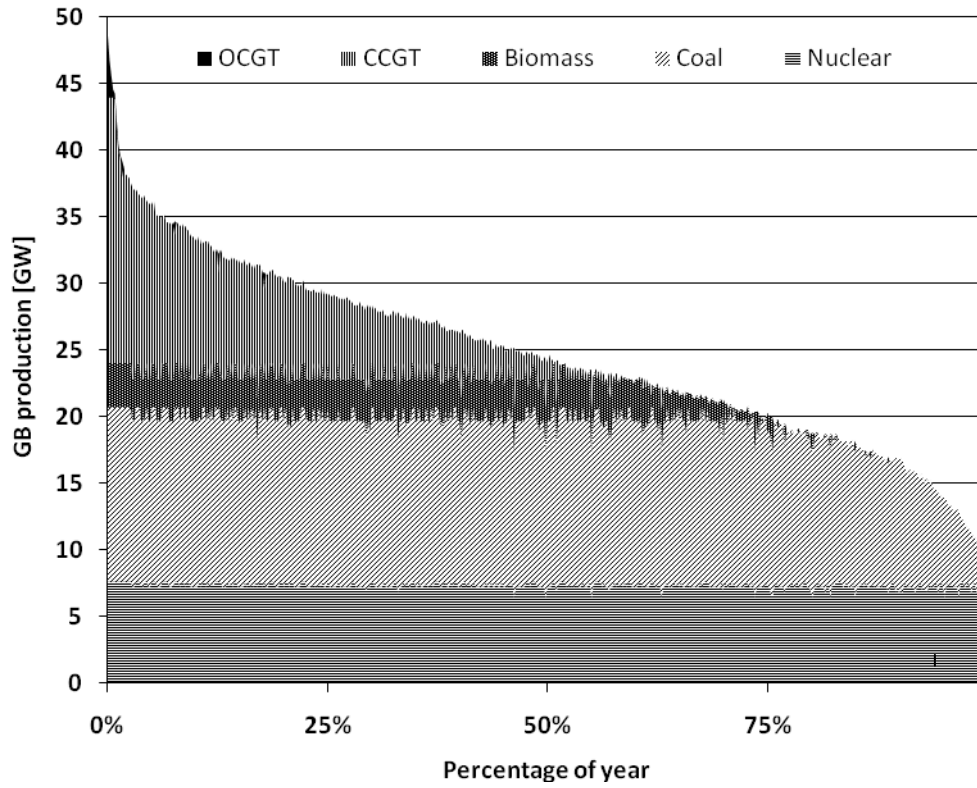

Figure 6. 2020 load duration in the Status Quo scenario, net of wind and hydro.

⁹ Defined as the average production, as a fraction of the installed capacity at the beginning of the period (including reserve capacity):

$$\frac{\sum_{i \in I} \sum_{t \in T} y_{2,g,i,t}^s}{\sum_{i \in I} [X_{0,g,i} (1 - \delta_g)^{10} + \Delta x_{1,g,i}]}$$

5.2 Comparison of Optimal Stochastic Solution with Traditional “Robustness” Analysis

Stochastic models are complicated and expensive to run; often, only deterministic (single scenario models) are available. For this reason, a more traditional type of robustness analysis can be performed using a deterministic model to derive an optimal plan for each scenario. Then, if the investments made right away (first-stage) in each of those plans are the same, a planner can be confident that this is the correct decision.¹⁰ A weaker definition of robust decisions is to identify as robust all individual investments that occur in each of the scenario-specific deterministic models (Lempert et al., 2006); such investments might be anticipated to also be part of the first-stage optimal investment strategy for the stochastic model (but are not necessarily so). Conversely, if a particular investment is chosen by none of the deterministic models, omitting it would be viewed as robust. Finally, those investments that appear only in some scenarios would be viewed as non-robust. A robust strategy might then be recommended that includes investments (if any) that occur in all the deterministic models, plus others that occur in most of those models, and excluding investments that occur in very few or no deterministic models. However, there is no guarantee that such a strategy would be optimal, or even nearly so, in the full stochastic model.

We conduct such a robustness analysis here. Table 16 shows the first stage decisions in the stochastic solution as well as in the deterministic (single scenario) model for each of the six scenarios; the second-stage decisions are shown as well for the latter models. The table shows that there are no robust alternatives. Alternative {2} is chosen in five scenario-specific models, while {1} is chosen in four models, and {3} in three. Alternatives {4,5} are never chosen. This deterministic-based robustness analysis might lead a planner to conclude that {4,5} should definitely not be chosen. Since five of six models choose {2}, it may be included in the most robust strategy, together with {1}, which is chosen in four of six models.

However, this is not what the stochastic model selects, which is instead {2,3}. Thus, the deterministic robustness analysis and stochastic model can diverge. On the other hand, as shown later in this paper, {1,2} performs almost as well on an expected cost basis as the optimal stochastic solution, so the inefficiency resulting from using the above deterministic robustness approach is not great.

Table 16. Transmission investment, stochastic and deterministic solutions

	First stage	Second stage
Stochastic	2,3	Paralysis: 1,5 All other scenarios: -
<i>Deterministic</i>		-
Status Quo	2	-

¹⁰ It can be proven that for a single decision maker problem, if the first stage decisions are identical in each deterministic model (one per scenario), then these are also the first stage decisions for a two-stage stochastic program considering the same scenarios in the second stage. This is because solving the stochastic program is, in essence, the same as solving the separate scenario models except with the constraint that the first-stage decisions are the same (non-anticipativity constraint); the fact that the separate models coincidentally satisfy this constraint without being forced to means that adding the constraint would not change the solution.

Low Cost DG	1,2,3	-
Low Cost Large Scale Green	1,2,3	-
Low Cost Conventional	-	-
Paralysis	1,2,3	-
Techno+	1,2	-

5.3. Expected Value of Perfect Information

Transmission and generation

The stochastic model discussed above results in an expansion plan that has the lowest expected cost, considering all scenarios. However, if in the first model period transmission and generation planners already knew which scenario would occur with certainty, they could devise an expansion plan tailored to that scenario that results in lower costs for that scenario. A separate deterministic expansion plan can be made for each scenario assuming such perfect forecasting ability; these are listed in Table 16 above, and Table 17. The probability-weighted average cost of these perfect information-based plans scenarios are necessarily lower (or at least no higher) than the expected cost of the stochastic model, the latter forcing the first-stage decision to be the same in each scenario. The decrease in expected cost then represents the costs resulting from imperfect information in the first model stage, or the expected value of perfect information (EVPI).

As table 16 shows, the deterministic plans are different across scenarios. All the chosen first-stage investments (1, 2 and 3) result in an increase in transmission capacity from Scotland to England. They differ in capacity, cost and region of connection in England, which is why different alternatives are chosen in different scenarios. Interestingly, there is no second-stage investment; even alternative 5, which is chosen in the second-stage of the stochastic model when the Paralysis scenario occurs, is never built. This illustrates one of the reasons why the EVPI is positive; the building of this transmission expansion alternative is avoided when, in the first stage, generation planners already anticipate the correct scenario and plan accordingly.

Table 18 lists the cost of each scenario's deterministic expansion plan. The resulting EVPI, at 3% of the total system costs in the stochastic model, is high. Note however, that this assumes that both transmission and generation planners have perfect foresight. The next section will explore the EVPI when only transmission planners have perfect foresight, while generators still face uncertainty.

It is noteworthy that, as in the stochastic model (with one exception), all transmission investment takes place in the first stage in the perfect information runs. This indicates that, in the stochastic model, it is not primarily the fact that the most extreme scenario has to be feasible which drives the preference for first-stage investment.

Table 17. Generation investment 2010 (MW), stochastic and deterministic solutions

	Onshore wind	Offshore wind	Biomass	Nuclear	CCGT	OCGT	Hydro
Stochastic	SCO: 8724 UNO: 1348 NOR: 5067 CEN: 4518 SWE: 2586 EST: 542	-	UNO: 1000 CEN: 887 SWE: 814 EST: 925	UNO: 293 CEN: 3217 EST: 584	UNO: 2234	SCO: 316 UNO: 4609 CEN: 3082 SWE: 1710 EST: 1532	-
<i>Deterministic:</i>							
Status Quo	SCO: 6000 UNO: 634 NOR: 3269 CEN: 2597 SWE: 2586 EST: 251	-	-	UNO: 2449 CEN: 537 SWE: 724 EST: 385	UNO: 1251	UNO: 3650 CEN: 4270 SWE: 1561 EST: 2295	-
Low Cost DG	SCO: 9834 UNO: 1348 NOR: 5067 CEN: 5426 SWE: 2586 EST: 542	-	-	CEN: 3217 EST: 877	UNO: 3586 CEN: 1911 SWE: 998	UNO: 3533 NOR: 573 CEN: 632 SWE: 1027	-
Low Cost Large Scale Green	SCO: 9834 UNO: 634 NOR: 5067 CEN: 4020 SWE: 2586 EST: 542	-	UNO: 1000 CEN: 887 SWE: 839 EST: 899	UNO: 837 CEN: 3217 EST: 40	-	UNO: 1230	-
Low Cost Conventional	SCO: 3834 NOR: 1472 SWE: 1713	-	-	UNO: 1833 CEN: 1721 SWE: 291 EST: 250	SCO: 404 UNO: 3721 SWE: 811 EST: 35	SCO: 641 UNO: 3061 NOR: 122 CEN: 5223 SWE: 1417 EST: 2862	-
Paralysis	SCO: 9834 UNO: 2061 NOR: 5067 CEN: 8255 SWE: 2586 EST: 833	SCO: 172	UNO: 925 CEN: 887 SWE: 814 EST: 1000	CEN: 3217 EST: 877	UNO: 6249 CEN: 2099 SWE: 831	SCO: 180 UNO: 2181 NOR: 1618 CEN: 10581 SWE: 1243 EST: 2083	UNO: 496 CEN: 500
Techno+	SCO: 8132 UNO: 1348 NOR: 5067 CEN: 5426 SWE: 2586 EST: 542	-	UNO: 1000 CEN: 887 SWE: 989 EST: 750	UNO: 2506 CEN: 1572 SWE: 16	-	SCO: 230 UNO: 4630 CEN: 4788 SWE: 1523 EST: 2287	-

Table 18. EVPI (Transmission + generation)

	Total costs	Savings resulting from perfect information
Stochastic	£123,559M	
<i>Deterministic:</i>		
Status Quo	£102,667M	£20,893M
Low Cost DG	£117,932M	£5,628M
Low Cost Large Scale Green	£97,214M	£26,346M
Low Cost Conventional	£108,850M	£14,709M
Paralysis	£165,398M	-£41,839M
Techno+	£126,923M	-£3,363M
<i>EVPI</i>		£3,729M
<i>EVPI (% of stochastic costs)</i>		3.02%

Transmission only

As explained in the methods section, it is also possible to calculate the EVPI when only transmission planners have perfect foresight, and do not share their information with generation planners. Generation planners act as Stackelberg followers, minimising expected costs across all scenarios, but observing the transmission expansion alternatives committed to by the transmission planner in stage 1 (2010). Table 19 shows the transmission investments made in each instance of this model, and Table 20 shows how the transmission-only EVPI is calculated.

This EVPI, at 0.08% of the costs in the stochastic model, is significantly lower than the EVPI when transmission and generation planners had perfect foresight. This indicates that most of the value of perfect information arises from the fact that generation planners can make better decisions on the siting and types of new plants. The value for transmission planners is lower, as in two out of six scenarios the optimal decision is the same as that in the stochastic model, and in three other scenarios the decision is very similar (as alternatives 1, 2 and 3 all provide additional transmission capacity to Scotland, albeit different capacities at different costs). However, some costs savings can still be made, most notably in the Paralysis scenario, where all investments are now made in the first stage, before they become more expensive in the second.

Table 19. Transmission investment, stochastic solution and deterministic solution where only transmission planners have perfect information.

	First stage	Second stage
Stochastic	2,3	Paralysis: 1,5
<i>Stochastic (transmission planner alone has perfect information)</i>		

Status Quo	1,2	-
Low Cost DG	2,3	-
Low Cost Large Scale Green	2,3	-
Low Cost Conventional	1,2	-
Paralysis	1,2,3,4,5	-
Techno+	1,2	-

Table 20. Transmission-only EVPI

	Total costs
Stochastic	£123,559,326,934
Stochastic (transmission planner alone has perfect information)	£123,457,746,636
Savings resulting from perfect information	£101,580,298
Savings (% of stochastic costs)	0.08%

5.4. Expected Cost of Ignoring Uncertainty

The EVPI quantifies the cost difference between the stochastic model and models where one or more actors have perfect foresight. Although the latter will result in lower costs than the stochastic model, it is unrealistic. Even stochastic optimisation is difficult, as all possible scenarios have to be identified, and optimisation problems of the size necessary to plan transmission are computationally intensive and difficult to solve, especially when they include nonlinearities. It is therefore important to quantify the benefits of stochastic planning over deterministic planning. This can be done using the ECIU.

Table 21 compares the total expected costs in the stochastic model with the total costs in each of the six naïve models. The ECIU is then calculated as the expected cost difference across all scenarios. As Table 21 shows, this average ECIU is comparable to the transmission-only EVPI.

However, the ECIU varies tremendously depending on which deterministic scenario is designated as the naïve scenario for the purposes of the deterministic model. In particular, the costs of ignoring uncertainty are especially large if the transmission planner plans for the Low Cost Conventional scenario because, in that case, there is no first-stage transmission investment, and high costs are incurred in stage 2 when lines are added in most of the scenarios. If instead any of the other five scenarios occur in stage 2, which is likely, the variable costs of generation will be much higher than necessary, as large amounts of renewable generation cannot be exported from regions with attractive wind resources. Table A.3 in the appendix lists the conditional second stage decisions for each of the six naïve models.

Meanwhile, the costs of ignoring uncertainty are relatively low in the Low Cost DG, Low Cost Large Scale Green and Paralysis scenarios, because there the naïve first-stage

transmission investments include the two first-stage lines that are optimal in the stochastic model, as well as one nearly optimal alternative,

Table 21. ECIU calculation

	First-stage transmission investment	Total expected costs considering all scenarios	Costs of ignoring uncertainty
Stochastic solution	2,3	£123,559M	
<i>Naïve solutions:</i>			
Status Quo	2	£123,670M	£111M
Low Cost DG	1,2,3	£123,564M	£4M
Low Cost Large Scale Green	1,2,3	£123,564M	£4M
Low Cost Conventional	-	£124,046M	£487M
Paralysis	1,2,3	£123,564M	£4M
Techno+	1,2	£123,566M	£7M
<i>Average</i>		£123,662M	£103M
<i>ECIU (% of stochastic costs)</i>			0.08%

5.5. Expected Cost of ignoring optionality (ECIO)

Here we quantify the value of using a two-stage modelling approach in which the transmission system can be adapted in stage two to the realised scenario. In order to do this, we specify a stochastic model in which the second-stage transmission decisions are constrained by non-anticipativity; they have to be the same in every scenario. That is, the planner is committing (in an open-loop fashion) to a transmission plan in 2010 for next two decades, as opposed to the stochastic model that only makes that commitment for year 2010 decisions. Since this open-loop model imposes additional constraints on investment compared to the original stochastic model, it cannot result in lower expected costs. However, they can be higher, and difference between the two is a measure of the additional costs resulting from the elimination of the option to “wait and see” until uncertainty is resolved.

In the model without this option, transmission alternatives 1, 2, and 3 are committed to in the first stage, whereas no transmission investment takes place in the second stage. Thus, the costs of ignoring optionality must be strictly positive, as alternative 3 is not in the optimal stochastic first-stage expansion plan. Rather, the stochastic model finds it preferable to wait and see whether that third line is economic, postponing its implementation to 2020 (in the Paralysis scenario) or never building it (in the other scenarios, where its benefits are less than its costs). As table 22 shows, at 0.02% of the total costs in the stochastic model, the cost of giving up the option is relatively low compared to the ECIU. It is, however, still significant, as a present discounted sum of nearly £27M is not negligible.

Table 22

	Total costs
Stochastic	£123,559M
Stochastic, no optionality	£123,586M

Costs of ignoring optionality	£27M
Costs of ignoring optionality (% of stochastic costs)	0.02%

5.6. Regret Analysis

Insight on the reasons for the selection of a particular first-stage decision by the stochastic model can be obtained by conducting a regret analysis. This is done by defining a set of alternative first-stage transmission investments, and then considering how each set performs under each of the scenarios. The stochastic model solution will have the lowest probability-weighted average cost over all scenarios; however, examination of the scenario-by-scenario performance of the stochastic solution relative to other possible first-stage investments will show why its average cost is better. Such an examination may also show that other investments might be advantageous in terms of, for instance, minimizing the risk of an extremely bad cost outcome. It is possible that, if transmission planners are risk-averse (i.e., willing to suffer a higher expected cost in order to lower the probability of bad outcomes), these other investments might be attractive.

To gain these insights, it is convenient to consider the “regret” that occurs if first-stage decisions are made assuming one scenario, but another occurs, possibly resulting in higher overall costs because a poor match of investments with system needs in the second stage as well as additional investment costs of adapting the solution in that stage. The regret matrix in Table 23 shows the cost difference between the optimal transmission expansion plan and every naïve plan (the regret), for each scenario. As before, generation planners still optimise considering the whole range of scenarios. By definition, regret is zero if the scenario planned for is the same the one that actually occurs, so the diagonal entries in the table are zero. In addition, we also show (in the last row of Table 23) the regret in each scenario resulting from implementing the stochastic model’s optimal first-stage solution (alternatives 2 and 3). The stochastic model, by definition, minimises the expected regret, since it can be shown that minimising expected costs (the stochastic model’s objective) is mathematically equivalent to minimising expected regret. Interestingly, the stochastic model’s first-stage decision (alternatives 2 and 3) is not optimal for any individual scenario, as the regret is positive in every case in the last row of the table, even though overall the stochastic solution has the lowest average cost. The stochastic solution has the highest regret if the low cost conventional scenario occurs; in this scenario building any transmission lines would be regretted, and significantly lower costs could have been achieved if none of the transmission lines were built, as is optimal in this scenario.

If we limit our consideration to first-stage solutions from deterministic models (Table 4), under the assumption that the stochastic model and its solution are unavailable, then use of the first-stage solutions (alternatives {1,2,3}) from the deterministic models based on the Low Cost DG, Low Cost Large Scale Green, or Paralysis scenarios will result in the lowest expected costs and regret, as indicated in the last column of Table 23. Their expected regret is the same because their first-stage decisions are identical. In contrast, for the first-stage decisions for the other scenarios, especially the Low Cost Conventional

scenario, the expected regret is higher, because the decisions made in anticipation of this scenario are further away from the optimal stochastic decisions.

Table 23. Regret matrix

Scenario (first-stage decisions)		Actual second-stage scenario ^a						Expected Value
		Status Quo	Low Cost DG	Low Cost Large Scale Green	Low Cost Conventional	Paralysis	Techno+	
Scenario used to derive first-stage decisions	Status Quo (2)	£0 (0.000%)	£211M (.171%)	£403M (0.362%)	£393M (0.318%)	£1,344M (1.088%)	£109M (0.088%)	£410M (0.332%)
	Low Cost DG (1,2,3)	£440M (0.356%)	£0 (.000%)	£0 (0.000%)	£1,238M (1.002%)	£0 (0.000%)	£144M (0.117%)	£304M (0.246%)
	Low Cost Large Scale Green (1,2,3)	£440M (0.356%)	£0 (.000%)	£0 (0.000%)	£1,238M (1.002%)	£0 (0.000%)	£144M (0.117%)	£304M (0.246%)
	Low Cost Conventional (none)	£56M (0.045%)	£447M (.362%)	£1,173M (0.949%)	£0 (0.000%)	£2,583M (2.090%)	£457M (0.370%)	£786M (0.636%)
	Paralysis (1,2,3)	£440M (0.356%)	£0 (.000%)	£0 (0.000%)	£1,238M (1.002%)	£0 (0.000%)	£144M (0.117%)	£304M (0.246%)
	Techno+ (1,2)	£266M (0.215%)	£54M (.043%)	£103M (0.083%)	£906M (0.734%)	£506M (0.410%)	£0 (0.000%)	£306M (0.248%)
Stochastic first-stage decision		£359M (0.290%)	£22M (.018%)	£59M (0.048%)	£1,081M (0.875%)	£234M (0.189%)	£41M (0.033%)	£299M (0.242%)

^a Cost difference between optimal and naively made plan for each scenario, in £M and as percentage of expected stochastic costs. Generators are assumed to consider all six scenarios, while the transmission planner only considers the listed scenario.

5.6. Considering Risk-Aversion.

Our stochastic modelling framework assumes risk-neutrality – that what planners care about is the expected cost. However, we can also consider which decisions risk-averse planners might make. In particular, a risk-averse planner might put a heavier weight on more negative outcomes, and prefer alternatives that have lower probabilities of such outcomes, even if their expected costs are the same. We consider two approaches to modelling risk aversion.¹¹

¹¹ However, the market equilibrium among electricity generators assumes they are risk neutral. It is quite possible that risk-averse generators will choose different mixes of investments. A few simple models have appeared in the literature, for instance of the effect of risk aversion upon the amount and mix of investments in generation technologies Fan et al. (2010) consider the effect effect upon natural gas versus coal choices when the source of risk is uncertain emissions regulation. Meanwhile, Morbée and Willems (2010) examine how the availability of financial risk hedging instruments affects investment in peaking versus baseload technologies.

The first approach to risk aversion is to instead assume that planners are risk averse over regret R (Bunn, 1984), maximizing a concave $U(R)$. For instance, planners might prefer to avoid first-stage decisions that could result in a very large regret in one scenario, even if the average regret is low compared to other alternatives. The extreme case of risk aversion would be the Min Max Regret (or Savage) criterion (Savage, 1951; Bunn, 1984). In this case, the planner chooses the first-stage decisions whose largest regret across scenarios is minimized. Table 23 shows that, with one exception, a given first-stage transmission decision results in the highest regret if the low cost conventional scenario actually occurs (the exception being, of course, the case where the planner actually expects that solution). Here, the Techno+ first-stage decision (alternatives 1 and 2) yields a lower maximum regret than the other possible first stage decisions. This reduction in the worst regret can be obtained at the expense of only a minor increase in expected costs, as Techno+'s first-stage decision increases expected cost only by a small amount compared to first-stage decisions that involve greater amounts of transmission capacity to Scotland. However, its maximum regret is less than any other solution's maximum regret by £175M; a planner might judge that mitigation of risk in the worst scenario to be worth the slight increases in expected costs.

In particular, the expected cost of Techno+'s first stage solution is only £2M more than those based on scenarios Low Cost DG, Low Cost Large Scale Green, or Paralysis scenarios (alternatives{1,2,3}), and is just £7M more than the expected cost of the optimal stochastic solution (alternatives {2,3}). It appears that additions of transmission capacity to Scotland beyond a certain point have slightly less expected benefits than costs, but that this capacity provides insurance against a high level of regret in the low cost conventional scenario. Thus, considering risk aversion can result in different decisions than assuming risk neutrality, at least in case where planners are risk averse with respect to regret.

A second, alternative representation of risk-aversion that we consider instead uses a concave utility function $U(C)$, where C is the present worth of cost, and then ranks alternatives by maximizing expected utility rather than minimizing expected cost (Clemen 2000). This can yield different recommendations than $U(R)$ or the Savage criterion (Bunn, 1984). We use the constant risk-aversion form $U(C) = a - be^{cX}$, with parameters $a, b, c > 0$, which is appropriate if C is to be minimized. The degree of relative risk aversion is determined by the parameter c ; the values of a and b do not affect the ranking of alternatives as long as they are positive.

By definition, if the transmission planner is risk-neutral ($c = \text{zero}$), then the stochastic solution's first stage investment {2,3} is optimal. However, if the planner is instead slightly to extremely risk averse (concave $U(C)$, resulting from small to large values of c) then instead building all three Scottish links {1,2,3} is optimal. This result occurs because, as Table 24 shows, that solution performs slightly better than the stochastic solution in the most unfortunate scenario (Paralysis).

This risk-averse decision differs strikingly from that resulting from a risk-averse utility function in regret $U(R)$, discussed above. In that case, it was the *smallest* amount (not largest) of transmission capability to Scotland from among the seven solutions in Tables 23 and 24 (solution {1,2}) that solved the "Min Max Regret" problem. This can happen because of certain theoretical deficiencies in the min max regret criterion that can result in its decisions diverging from those based on utility functions (Bunn, 1984). Meanwhile, it turns out that from among the first-stage solutions represented by the rows of Table 24,

investing in just lines {1,2} is best if the planner is instead risk *seeking* (convex $U(C)$, resulting from a slightly to very negative c), which is an unlikely risk attitude. Thus, although the risk-averse $U(R)$ and $U(C)$ analyses yielded very different choices, they both differ from the risk-neutral solution {2,3}. Therefore, we conclude that consideration of risk aversion can change the optimal first-stage decisions in transmission planning.

Table 24. Present worth of costs from a given first-stage transmission decision, with generation optimizing over all six scenarios in both stages, and second-stage transmission investments allowed to differ between scenarios

Scenario (First-stage decisions)		Actual second-stage scenario						Expected
		Status Quo	Low Cost DG	Low Cost Large Scale Green	Low Cost Conventional	Paralysis	Techno+	
Scenario used to derive first-stage decisions	Status Quo (2)	106,435M	120,576M	104,174M	113,743M	169,988M	127,104M	123,670M
	Low Cost DG (1,2,3)	106,875M	120,365M	103,771M	114,588M	168,644M	127,139M	123,564M
	Low Cost Large Scale Green (1,2,3)	106,875M	120,365M	103,771M	114,588M	168,644M	127,139M	123,564M
	Low Cost Conventional (None)	106,491M	120,813M	104,944M	113,350M	171,227M	127,452M	124,046M
	Paralyses (1,2,3)	106,875M	120,365M	103,771M	114,588M	168,644M	127,139M	123,564M
	Techno+ (1,2)	106,701M	120,419M	103,874M	114,256M	169,150M	126,995M	123,566M
	Stochastic first-stage decision	106,794M	120,388M	103,830M	114,431M	168,878M	127,036M	123,559M

6. Conclusions

In this paper, we have proposed and demonstrated a two-stage optimization framework to assess the importance of uncertainty for national-scale electricity transmission expansion planning. Two-stage optimization captures the reality that investment decisions today have to be made in ignorance of which of several demand, policy, fuel price, and other scenarios will occur in the future, while later decisions will be better informed but involve costs of delay as well. Although the results described above were obtained under restrictive assumptions and may not reflect all complexities of the real-world planning process, we show that ignoring risk has quantifiable economic consequences, and that there is a quantifiable value of optionality. In general and in our particular case study, two-stage optimization results in different recommendations for near-term investments than either planning for a single scenario or a robustness analysis that considers which near-term

commitments are common to several single scenario models. We also show that an aversion to risk can result in different recommendations than a risk-neutral attitude (expected cost minimization). Hence, recognizing uncertainty explicitly in planning can be useful in answering policy and planning questions, not just in electricity transmission planning, but in a wide range of applications.

References

- Awad, M., Casey, K.E., Geevarghese, A.S., Miller, J.C., Rahimi, A.F., Sheffrin, A.Y., Zhang, M., Toolson, E., Drayton, G., Hobbs, B.F., Wolak, F.A., 2010. Economic assessment of transmission upgrades: Application of the California ISO approach, in: Zhang, X.-P. (Ed.), *Restructured electric power systems: Analysis of electricity markets with equilibrium models*, IEEE Press, Piscataway.
- Bartels, M., Gatzen, C., Peek, M., Schulz, W., Wissen, R., 2006. Planning of the grid integration of wind energy in Germany onshore and offshore up to the year 2020. *Int. J. Global Energy Issues* 25(3/4), 257–275.
- Birge, J.R., 1982. The value of the stochastic solution in stochastic linear programs with fixed recourse. *Mathematical Programming* 24, 314–325.
- Birge, J.R., Louveaux, F., 1997. *Introduction to stochastic programming*. Springer, New York.
- Bresemi, P., Capasso, A., Falvo, M.C., Lauria, S., 2003. Power system planning under uncertainty conditions: criteria for transmission network flexibility evaluation. *Proc. 2003 IEEE Power Tech Conf*.
- Bunn, D., 1984. *Applied Decision Analysis*. McGraw-Hill, New York.
- California ISO, 2010. Renewable energy transmission planning process (RETPP): draft final proposal, www.caiso.com/242a/242abe1517440.html.
- Capasso, A., Falvo, M.C., Lamedica, R., Lauria, S., Scalcino, S., 2005. A new methodology for power systems flexibility evaluation. *Proc. 2005 IEEE Power Tech Conf*, 1–6.
- Clemen, R.T., Reilly, T., 2001. *Making hard decisions*. Duxbury, Pacific Grove.
- Crousillat, E.O., Dörfner, P., Alvarado, P., Merrill, H.M., 1993. Conflicting objectives and risk in power system planning. *IEEE Trans. Power Systems* 8, 887–893.
- De la Torre, T., Feltes, J.W., Gómez San Román, T., Merrill, H.M., 1999. Deregulation, privatization, and competition: transmission planning under uncertainty. *IEEE Trans. Power Systems* 14, 460–465.
- DECC, 2009. *Digest of UK energy statistics*.
- De Dios, R., Sanz, S., Alonso, J.F., Soto, F., 2009. Long-term grid expansion: Spanish plan 2030. *Proc. CIGRE Symposium on Operation and Development of Power Systems in the New Context*.
- Duncan, N., 2010. Run-of-the-river hydroelectric output.
- EIA, 1999. *The comprehensive electricity competition act: a comparison of model results*.
- ENSG, 2009. *Our electricity transmission network: a vision for 2020*.
- Feng, Y., Tavner, P.J., Long, H., Bialek, J.W., 2010. Review of early operation of UK round 1 offshore wind farms. *Proc. IEEE PES 2010 General Meeting*.
- First Hydro Company, 2010. Dinorwig power station. <http://www.fhc.co.uk/dinorwig.htm>. [Accessed 20 July 2010].
- Fleten, S.-E., Heggedal, A. M., Siddiqui, A., 2009. Transmission investment under uncertainty: the case of Germany-Norway. *Proc 1st International Ruhr Energy Conference*.
- Garcés, L.P., Conejo, A.J., García-Bertrand, R., Romero, R., 2009. A bilevel approach to transmission expansion planning within a market environment. *IEEE Trans. Power Systems* 24, 1513–1522.
- Garrad Hassan, 2001. *Scotland's renewable resource*.

- Greene, N., Hammerschlag, R., 2000. Small and clean is beautiful: exploring the emissions of distributed generation and pollution prevention. *The Electricity Journal* 13(5), 50–60.
- Hedman, K.W., Gao, F., Sheble, G.B., 2005. Overview of transmission expansion planning using real options analysis. *Proc. IEEE North American Power Symposium 2005*.
- Hobbs, B.F., Drayton, G., Fisher, E.B., Lise, W., 2008. Improved transmission representations in oligopolistic market models: Quadratic losses, phase shifters, and DC lines. *IEEE Trans. Power Systems* 23(3): 1018-1029.
- Hu, M.-C., Hobbs, B.F., 2010. Analysis of multipollutant policies for the U.S. power sector under technology and policy uncertainty using MARKAL. *Energy*, doi:10.1016/j.energy.2010.07.001.
- Hyung Roh, J., Shahidehpour, M., Wu, L., 2009. Market-based generation and transmission planning with uncertainties. *IEEE Trans. Power Systems* 24, 1587–1598.
- IPCC, 2005. *Carbon Dioxide Capture and Storage*. Cambridge University Press, Cambridge.
- KEMA, 2009. Assessment of overall robustness of the transmission investment proposed for additional funding by the three GB electricity transmission owners.
- Lempert, R.J., Groves, D.G., Popper, S.W., and Bankes, S.C., 2006. A general, analytic method for generating robust strategies and narrative scenarios. *Management Science* 52(4), 514–528.
- Lin, F., Hobbs, B.F., and Norman, C.S., 2010. Risk aversion and CO₂ regulatory uncertainty in power generation investment: policy and modeling implications. *Journal of Environmental Economics & Management*, 60(3), 193-208.
- London Economics, 2003. Economic evaluation of the Path 15 and Path 26 transmission expansion projects in California.
- Morbée, J., and Willems, B. 2010. Risk management in electricity markets: hedging and market incompleteness. *Energy Economics* 32(4), pp 786-795.
- Morgan, M.G., Henrion, M., Small, M., 1990. *Uncertainty: a guide to dealing with uncertainty in quantitative risk and policy analysis*. Cambridge University Press, Cambridge.
- National Grid, 2008. Investigation into transmission losses on UK electricity transmission system, June, <http://www.nationalgrid.com/NR/rdonlyres/4D65944B-DE42-4FF4-88DF-BC6A81EFA09B/26920/ElectricityTransmissionLossesReport1.pdf> [Accessed 20 July 2010].
- National Grid, 2009. Seven-year statement.
- National Grid, 2010. Metered half-hourly electricity demand. <http://www.nationalgrid.com/uk/Electricity/Data/>. [Accessed 20 July 2010].
- Neuhoff, K. Cust, J., Keats, K., 2007. Modelling wind in the electricity sector. *EPRG Working Paper 0711*.
- Neuhoff, K., Cust, J., Butler, L., Keats, K., Hoexter, H., Kreckzo, A., Sinden, G., Ehrenmann, A., 2006. Space and time: wind in an investment planning model. *EPRG Working Paper 0603*.
- NEA, IEA, 2005. Projected costs of generating electricity – 2005 update. Nuclear Energy Agency and International Agency, OECD, Paris.
- Ng, S.K.K., Lee, C.W., Zhong, J., 2006. A game-theoretic approach to study strategic interaction between transmission and generation expansion planning. *Proc. 38th N. Am. Power Symp.*, 115–120
- Office for National Statistics, 2010. Focus on consumer price indices. <http://www.statistics.gov.uk/statbase/product.asp?vlnk=867>. [Accessed 20 July 2010].

- Oloomi Buygi, M., Shahidehpour, M., Shanechi, H.M., Balzer, G., 2004, Market based transmission planning under uncertainties. Proc. 2004 Int. Conf. on Probabilistic Methods Applied to Power Systems, 563–568.
- Oliveira, G.C., Binato, S., Pereira, M.W., 2007. Value-based transmission expansion planning of hydrothermal systems under uncertainty. IEEE Trans. Power Systems 22, 1429–1435.
- Parail, V., 2009. Can merchant interconnectors deliver lower and more stable prices? The case of NorNed. EPRG Working Papers 0926.
- Parliamentary Office of Science and Technology, 2006. Carbon footprint of electricity generation. Postnote 268.
- Pollitt, M.G., 2009. Electricity liberalisation in the European Union: A progress report. EPRG Working Paper 0929.
- Sauma, E.E., Oren, S.S., 2006. Proactive planning and valuation of transmission investments in restructured electricity markets. J. Regulatory Economics 30, 261–290.
- Savage, L. J., 1951. The theory of statistical decision. J. Am. Stat. Assoc. 46, 55–67.
- Shahidehpour M., 2004. Investing in expansion: the many issues that cloud transmission planning. IEEE Power & Energy Mag 2(1),14-18.
- Sinden, G., 2007. Characteristics of the UK wind resource: long-term patterns and relationship to electricity demand. Energy Policy 35(1), 112–127.
- Sørensen, B., 2004. Renewable energy. Elsevier, Burlington MA.
- Sozer, S., Park, C.S., Valenzuela, J., 2006. Considering uncertainty in transmission expansion planning for restructured markets. Auburn University Working Paper.
- Thomas, R. J., Whitehead. J. T., Outhred. H., Mount, T. D., 2005. Transmission system planning: the old world meets the new. Proc. IEEE 93(11), 2026–2035.
- Tor, O.B., Guven, A.N., Shahidehpour, M., 2008. Congestion-driven transmission planning considering the impact of generator expansion. IEEE Trans. Power Systems 23(2), 781–789
- Vazquez, P., Olsina, F., 2007. Valuing flexibility of DG investments in transmission expansion planning. Proc. IEEE PowerTech, 695–700.
- Zhao, J.H., Zhao, Y.D., Lindsay, P., Wong, K.P., 2009. Flexible transmission expansion planning with uncertainties in an electricity market. IEEE Trans. Power Systems 24(1), 479–488.

Appendix A. Supplementary tables

Table A.1. Population moments

		Demand						Wind							
		SCO	UNO	NOR	MID	CEN	SWE	EST	SCO	UNO	NOR	MID	CEN	SWE	EST
Demand	UNO	0.68													
	NOR	0.87	0.86												
	MID	0.72	0.97	0.89											
	CEN	0.77	0.95	0.89	0.97										
	SWE	0.82	0.87	0.87	0.91	0.94									
	EST	-0.19	-0.22	-0.23	-0.22	-0.20	-0.17								
Wind	SCO	0.20	0.16	0.18	0.18	0.19	0.22	-0.10							
	UNO	0.27	0.23	0.26	0.25	0.26	0.29	-0.05	0.58						
	NOR	0.08	0.15	0.12	0.14	0.13	0.13	0.03	0.42	0.52					
	MID	0.24	0.24	0.26	0.25	0.26	0.27	0.01	0.34	0.69	0.61				
	CEN	0.30	0.24	0.29	0.26	0.27	0.29	0.00	0.29	0.60	0.55	0.87			
	SWE	0.29	0.22	0.27	0.24	0.25	0.27	0.02	0.33	0.50	0.51	0.72	0.80		
	EST	0.26	0.22	0.24	0.24	0.25	0.27	0.04	0.13	0.42	0.38	0.68	0.76	0.55	
	mean	2940	1497	8113	4502	13053	1658	1234	391	280	335	191	287	381	288
	sd	556	367	1242	1054	3013	346	1549	246	291	209	223	251	334	320

Table A.2. Sample moments

		Demand							Wind						
		SCO	UNO	NOR	MID	CEN	SWE	EST	SCO	UNO	NOR	MID	CEN	SWE	EST
Demand	UNO	0.67													
	NOR	0.86	0.85												
	MID	0.71	0.97	0.89											
	CEN	0.76	0.95	0.88	0.97										
	SWE	0.81	0.86	0.86	0.90	0.93									
	EST	-0.33	-0.55	-0.43	-0.56	-0.53	-0.46								
Wind	SCO	0.19	0.08	0.13	0.11	0.12	0.18	-0.16							
	UNO	0.30	0.20	0.28	0.23	0.26	0.29	-0.16	0.61						
	NOR	0.17	0.18	0.21	0.17	0.16	0.18	-0.06	0.41	0.49					
	MID	0.27	0.23	0.30	0.25	0.27	0.28	-0.14	0.34	0.66	0.61				
	CEN	0.34	0.24	0.34	0.27	0.29	0.32	-0.14	0.29	0.60	0.57	0.88			
	SWE	0.29	0.17	0.26	0.20	0.22	0.26	-0.09	0.34	0.51	0.52	0.73	0.80		
	EST	0.26	0.20	0.25	0.22	0.25	0.26	-0.09	0.13	0.42	0.41	0.71	0.75	0.54	
	mean	2941	1485	8080	4460	12973	1657	1717	398	279	336	180	271	368	273
	sd	550	367	1217	1033	2988	339	1403	246	290	201	216	244	329	304

Table A.3. Decisions in all naive models

		First stage	Second stage, actual second-stage scenario					
			Status Quo	Low Cost DG	Low Cost Large Scale Green	Low Cost Conventional	Paralysis	Techno+
Scenario used to derive first-stage decisions	Status Quo	2	-	1	1	-	3,5	1
	Low Cost DG	1,2,3	-	-	-	-	5	-
	Low Cost Large Scale Green	1,2,3	-	-	-	-	5	-
	Low Cost Conventional	-	-	3	1,2	-	1,2,4,5	1,2
	Paralysis	1,2,3	-	-	-	-	5	-
	Techno+	1,2	-	-	-	-	3,5	-

Appendix B. Mathematical definitions

Optimal Stochastic Solution

Let X_1 and Z_1 represent first-stage generation and transmission investment decisions respectively, while X_{2s} and Z_{2s} represent second-stage investments in each scenario s . Let $C_1(X_1, Z_1)$ represent the present worth of first stage investment costs as well as the optimal operating costs associated with operating a system with those investments (in this model, 2010 investments and 2020 operations). $C_{2s}(X_1, Z_1, X_{2s}, Z_{2s})$ is the present worth of the investment costs of the second stage investments plus the subsequent optimal operating costs of the system, which depend on all the investments. (In this paper, the stage two investments are committed to in 2020, while the operating costs occur in the 2030s.) All constraints are implicit in these cost functions. Let P_s be the probability of each scenario. The expected cost of the optimal stochastic solution is:

$$ECCS^* = \min_{\{X_1, Z_1, X_{2s}, Z_{2s}\}} C_1(X_1, Z_1) + \sum_s P_s C_{2s}(X_1, Z_1, X_{2s}, Z_{2s})$$

EVPI

The expected cost under perfect information for both generation and transmission decisions is:

$$ECPI^* = \min_{\{X_1, Z_1, X_{2s}, Z_{2s}\}} \sum_s P_s [C_1(X_1, Z_1) + C_{2s}(X_1, Z_1, X_{2s}, Z_{2s})] \equiv \sum_s P_s \cdot CPI_s(X_{1s}^*, Z_{1s}^*, X_{2s}^*, Z_{2s}^*)$$

where X_{1s} and Z_{1s} are investments that are chosen knowing that scenario s will happen with probability 1. In general, the optimal values of these investments (indicated by an asterisk) differ for different scenarios: $\{X_{1s}^*, Z_{1s}^*\} \neq \{X_{1s'}^*, Z_{1s'}^*\}$ for $s \neq s'$. $CPI_s(X_{1s}^*, Z_{1s}^*, X_{2s}^*, Z_{2s}^*)$ is defined as the cost if planning is done assuming that scenario s occurs, and it indeed does occur. $ECPI^*$ is generally less than $ECSS^*$, because the first-stage investments can be tailored for the scenario. So the expected value of perfect information is:

$$EVPI = ECSS^* - ECPI^*$$

If only transmission decisions are taken under perfect information, then the calculation is more complicated. In this calculation, the transmission planner knows what scenario will be realized, but the generation planner does not. As a result, the transmission planner can tailor their first-stage decisions Z_{1s} to the scenario s , but generators cannot. The resulting expected cost in this situation is:

$$ECPIT^* = \min_{\{X_1, Z_1, X_{2s}, Z_{2s}\}} \sum_s P_s [C_1(X_1, Z_1) + C_{2s}(X_1, Z_1, X_{2s}, Z_{2s})] \equiv \sum_s P_s CPIT_s(X_{1s}^*, Z_{1s}^*, X_{2s}^*, Z_{2s}^*)$$

The optimal transmission decisions in different scenarios will in general differ: $Z_{1s}^* \neq Z_{1s'}^*$ for $s \neq s'$. $CPIT_s(X_{1s}^*, Z_{1s}^*, X_{2s}^*, Z_{2s}^*)$ is defined as the expected cost if transmission alone is planned in the first period based on scenario s , and that scenario actually occurs; generation is planned considering all scenarios.

Because of flexibility resulting from the use of Z_{1s} rather than Z_1 , $ECPIT^*$ is no more than $ECSS^*$. Thus, we can define $EVPI^*$, the expected value of perfect information for transmission only, as:

$$EVPIT = ECSS^* - ECPIT^*$$

Robustness Analysis.

Robust first-stage decisions can be defined using deterministic models in several ways. We define them as first-stage transmission investments that are made in all deterministic models. Thus, we look at the elements of Z_{1s}^* from $\{X_{1s}^*, Z_{1s}^*\}$ (defined above as part of the EVPI calculations), and determine which ones equal 1 (signifying an investment is made for all s). These are robust investments choices. This procedure can also be followed with the Z_{1s}^* resulting from the EVPIT calculations. However, since the point of robustness analysis is that it can be done with (smaller) deterministic models, the latter procedure is of less interest, since the selection of Z_{1s}^* in the EVPIT calculations requires the solution of a stochastic program (the equation for ECPIT*, above).

ECIU

The expected cost of ignoring uncertainty in both transmission and generation decisions is calculated first by determining the expected cost associated with the first-stage investment decisions $\{X_{1s}^*, Z_{1s}^*\}$ optimized under the naïve assumption that scenario s would occur with probability 1. Those decisions were previously obtained when calculating the EVPI for both transmission and generation. The expected cost of those decisions is:

$$\begin{aligned} EC(X_{1s}^*, Z_{1s}^*) &= C_1(X_{1s}^*, Z_{1s}^*) + \sum_s P_s \cdot \min_{\{X_{2s'}, Z_{2s'}\}} C_{2s}(X_{1s}^*, Z_{1s}^*, X_{2s'}, Z_{2s'}) \\ &= \sum_s P_s \cdot \min_{\{X_{2s'}, Z_{2s'}\}} C_1(X_{1s}^*, Z_{1s}^*) + C_{2s}(X_{1s}^*, Z_{1s}^*, X_{2s'}, Z_{2s'}) \\ &\equiv \sum_s P_s \cdot CPIT_s(X_{1s}^*, Z_{1s}^*, X_{2s'}, Z_{2s'}) \end{aligned}$$

where $CPIT_s(X_{1s}^*, Z_{1s}^*, X_{2s'}, Z_{2s'})$ is the sum of C_1 and C_{2s} if scenario s is planned for when making transmission investments in stage one, but scenario s' instead occurs. If scenario s is assumed to be the 'naïve' scenario that is used for deterministic planning, then we can define the cost of ignoring uncertainty as:

$$CIU(X_{1s}^*, Z_{1s}^*) = EC(X_{1s}^*, Z_{1s}^*) - ECSS^*$$

which is the expected cost increase if the naïve plan is adopted rather than the optimal stochastic plan. If we don't necessarily know which naïve scenario might be the basis of a deterministic plan, then it is reasonable to calculate an average CIU over the possible naïve scenarios:

$$ECIU = \sum_s P_s \cdot CIU(X_{1s}^*, Z_{1s}^*)$$

On the other hand, if only the transmission grid plans naively while the generators recognize the possibility of several different scenarios, we can obtain an ECIU for transmission only (ECIUT) as follows. Recall the optimal first-stage grid investment decisions Z_{1s}^* , when transmission but not generation had perfect information (in the EVPIT calculations, above). The expected cost that occurs when Z_{1s}^* is imposed upon all second stages is:

$$EC(Z_{1s}^*) = \min_{\{X_1, X_{2s'}, Z_{2s'}\}} C_1(X_1, Z_{1s}^*) + \sum_s P_s C_{2s}(X_1, Z_{1s}^*, X_{2s'}, Z_{2s'})$$

Analogous to the above calculations of CIU, we can calculate CIUT, the expected cost if transmission planners ignore uncertainty, as follows. First, let scenario s be the “naïve” scenario that is used for deterministic planning, so:

$$CIUT(Z_{1s}^*) = EC(Z_{1s}^*) - ECCS^*$$

This is the expected penalty resulting from adopting the naïve plan Z_{1s}^* rather than the optimal stochastic plan. As in the ECIU calculations, if we do not want to make an assumption about which naïve scenario would be the basis of deterministic planning, we can calculate an expected CIUT over the scenarios:

$$ECIUT = \sum_s P_s \cdot CIUT(Z_{1s}^*)$$

ECIO

The cost of ignoring options is obtained by first calculating ECNO*, the expected cost given that “one’s hands are tied”, in that the same second stage as well as first stage transmission decisions are imposed in all scenarios.

$$ECNO^* = \min_{\{X_1, Z_1, X_{2s}, Z_2\}} C_1(X_1, Z_1) + \sum_s P_s C_{2s}(X_1, Z_1, X_{2s}, Z_2)$$

Note that Z_2 rather than Z_{2s} is used in the second stage – this means that the same set of transmission investments are made in each scenario. However, generation investment decisions are allowed to vary by scenario. Thus, we are calculating ECIO only for transmission investments; it is also possible to calculate it for both transmission and generation investment simultaneously, but this is of less interest. We can now calculate ECIO as the increase in expected cost resulting from tying our hands, relative to the optimal stochastic solution:

$$ECIO = ECNO^* - ECSS^*$$

Regret Analysis

We calculate regret only for transmission investment decisions in the first stage, allowing generation investments to be made considering all scenarios. The set of first stage transmission decisions we consider are $\{Z_{1s}^*, \forall s\}$ from the EVCIT analysis plus Z_1^* , the optimal first stage decision in the stochastic analysis. In our case study, there are seven such investment plans, although the number of distinct ones are less because they are identical for some s . The regret R experienced if plan Z_{1s}^* is chosen in the first-stage but scenario s' is actually realized in the second-stage is defined as:

$$R(Z_{1s}^*, s') = CPIT_{s'}(X_{1s}^*, Z_{1s}^*, X_{2s'}, Z_{2s'}) - CPIT_s(X_1^*, Z_{1s}^*, X_{2s}, Z_{2s}^*)$$

where $CPIT_{s'}(\cdot)$ and $CPIT_s(\cdot)$ were defined above. The first term is the cost that occurs if the first-stage transmission investments were planned based on scenario s (Z_{1s}^*), but instead scenario s' occurs, and the market adapts by making decisions $\{X_{2s'}, Z_{2s'}\}$ in the second stage. The second term is the happier (lower cost) situation in which scenario s was planned for by transmission, and indeed occurs – so that cost is necessarily no higher than the first term, and regret is nonnegative.

The min-max regret (Wald) criterion is defined as follows: choose the Z_{1s}^* that yields the lowest regret across scenarios:

$$\min_{\{Z_{1s}^*\}} \max_{\{s'\}} R(Z_{1s}^*, s')$$

In our application, we consider Z_1^* as one of the first-stage transmission options that can be chosen, as well as Z_{1s}^* .

Expected Utility Analysis.

Let $U(C)$ be the utility of a present worth of cost C . Our expected utility analysis considers a concave (risk-averse) utility function, as described above. For various utility functions, we maximize expected utility from among the possible $\{Z_{1s}^*, \forall s\}$ from the EVCIT analysis (as well as Z_1^* , the optimal first stage decision in the stochastic analysis) as follows:

$$\max_{\{Z_{1s}^*\}} \sum_s P_s \cdot U \cdot CPIT_s(X_1^*, Z_{1s}^*, X_{2s}^*, Z_{2s}^*)$$

As explained above, $CPIT_s(\cdot)$ is the present worth of cost that occurs if the first-stage transmission investments were planned based on scenario s (Z_{1s}^*), but instead scenario s' occurs, with the market adjusting by making decisions $\{X_{2s}^*, Z_{2s}^*\}$ in the second stage.