

WHOLE BODY VIBRATION ANALYSIS FOR RIDE
QUALITY OF LRT PASSENGER

AHMAD ABQARI BIN ABU SAMAH

UNIVERSITI TUN HUSSEIN ONN MALAYSIA

WHOLE BODY VIBRATION ANALYSIS FOR RIDE QUALITY OF LRT
PASSENGER

AHMAD ABQARI BIN ABU SAMAH

A thesis is submitted in partial
fulfillment of the requirement for the award of the
Degree of Master of Science in Railway Engineering

CENTRE FOR GRADUATE STUDIES
UNIVERSITI TUN HUSSEIN ONN MALAYSIA

FEBRUARY 2016

*Specially dedicated to my beloved family,
“Thank you for the endless support and inspiration”*

*To my supervisor & co-supervisor,
Prof. Dr Khalid Bin Hasnan
&
Dr. Mohd Azlis Sani Bin Md Jalil
“Thank you for the guidance and advices”*

*Not forgotten to Prasarana staff and all my friends,
“Let’s carve the success in our journey”*

ACKNOWLEDGEMENT

In the name of Allah, The Most Gracious and The Most Merciful

This project would not have been possible without the guidance and the help of several individuals who in one way or another contributed and extended their valuable assistance in the preparation and completion of this study.

First and foremost, I would like to express my sincere gratitude and appreciation to my supervisor and co-supervisor to this project, Professor Dr. Khalid Bin Hasnan for the valuable guidance and advice as well as Dr. Mohd Azlis Sani Bin Md Jalil. They inspired me to work on this project and their willingness to motivate me contribute tremendously to this project.

Besides, I would like to thank you University Tun Hussein Onn Malaysia and Prasarana Malaysia Berhad for providing the best environment and facilities to complete this project.

My special thanks to Mr. Ahmad Fuad Bin Mohd Noor and Mr. S. M. Sabri Ismail, Prasarana Head of Research and Development Department, for their taught, explanation, and ideas to effectively use the equipment in the laboratory and the train.

Last but not least, honorable mention goes to my family and friends for their understanding and supports in completing this project. Without the help of those that mentioned above, I would have face many difficulties. Finally, I hope this study can be an inspiration and reference for future studies particularly in railway engineering.

ABSTRACT

Ride comfort in railway transportation is quite complex and it depends on various dynamic performance criteria and subjective perception from the train passengers. Vibration discomfort from various factors such as vehicle conditions, track sections condition, and operating condition can lead to the poor ride comfort. In the current works, the whole body vibration exposure levels and ride comfort levels of LRT Ampang were measured and analyzed. Human vibration meter and accelerometer sensor were used to measure vibration magnitude in seating and standing position. BS EN 12299 standards were used as guideline to measure and evaluate ride comfort assessment N_{MV} , N_{VD} , and N_{va} of train passenger in three different routes. Data result shows high vibration magnitude in vertical axis which influences the overall result. Standing position shows high vibration exposure in all three routes tested. Ride comfort assessment of passenger in sitting and standing position shows that all three different routes exceed the uncomfortable limit of 3.02 m/s^2 , 3.6 m/s^2 , 3.48 m/s^2 for standing and 2.71 m/s^2 , 3.03 m/s^2 , and 3.23 m/s^2 for sitting position respectively. On the perception analysis, total 100 passengers were randomly selected for the questionnaire survey. As per questionnaire survey, 22% of the passenger reported having uncomfortable ride, whereas 23% had uncomfortable due to noise condition, 24% due to shaking condition and 31% passenger had uncomfortable ride comfort due to the seat design. Recommendations to improve current situation include upgrading interior condition of the train and review maintenance program of the problematic track section.

ABSTRAK

Keselesaan perjalanan di dalam perkhidmatan pengangkutan kereta api adalah kompleks bergantung kepada prestasi dinamik dan persepsi daripada penumpang. Ketidakselesaan getaran disebabkan daripada pelbagai faktor antaranya keadaan kenderaan, keadaan trek dan keadaan operasi menyumbang kepada ketidakselesaan getaran yang mempengaruhi keselesaan perjalanan. WBV dan keselesaan perjalanan telah diukur dan dianalisis dari LRT jajaran Ampang. Meter getaran dan sensor digunakan di dalam kajian untuk mengukur tahap getaran yang dihasilkan oleh tren terhadap penumpang di dalam posisi duduk dan berdiri. Piawai BS EN 12299 digunakan untuk dijadikan panduan di dalam analisa tahap keselesaan penumpang di tiga kawasan trek yang berbeza. Analisis keselesaan perjalanan di tiga kawasan trek menunjukkan bahawa kesemua kawasan trek telah melepasi tahap keselesaan yang dibenarkan mengikut piawai iaitu 3.02 m/s^2 , 3.6 m/s^2 , 3.48 m/s^2 untuk posisi berdiri dan 2.71 m/s^2 , 3.03 m/s^2 , dan 3.23 m/s^2 untuk posisi duduk. Analisis persepsi digunakan dengan memilih 100 penumpang untuk menjawab soal selidik yang diberikan dan seramai 22% menyatakan mereka merasa tidak selesa ketika di dalam perjalanan, manakala 23% mengatakan keadaan di dalam kabin terlalu bising, 24% menyatakan keadaan kabin terlalu bergetar, dan 31% menyatakan ketidakselesaan disebabkan faktor tempat duduk penumpang. Cadangan penambahbaikan untuk meningkatkan keselesaan penumpang termasuk membaik pulih fasiliti dalaman tren dan mengkaji semula program penyelenggaraan bagi trek yang mengalami masalah.

TABLE OF CONTENT

	TITLE	i
	DEDICATION	iii
	ACKNOWLEDGEMENT	iv
	ABSTRACT	v
	ABSTRAK	vi
	CONTENTS	vii
	LIST OF TABLES	xi
	LIST OF FIGURES	xiii
	LIST OF EQUATIONS	xv
	LIST OF SYMBOLS AND ABBREVIATIONS	xvi
	LIST APPENDICES	xviii
CHAPTER 1	INTRODUCTION	1
	1.1 Research background	1
	1.2 Problem statement	3
	1.3 Objective of research	3
	1.4 Important of research	3
	1.5 Scope of study	4
	1.6 Research outcomes	4
CHAPTER 2	LITERATURE REVIEW	5
	2.1 Introduction	5
	2.2 Railway track	6
	2.2.1 Condition monitoring and track irregularity	7
	2.3 Vibration	8
	2.4 Effect of vibration towards train passenger	10

2.5	Non peak hour measurement	11
2.6	Whole body vibration (WBV)	11
2.6.1	Root-mean-square (R.M.S)	14
2.6.2	Vibration dose value (VDV)	15
2.6.3	Frequency and frequency weighting	15
2.6.4	Seat effective amplitude transmissibility	17
2.7	Ride comfort	18
2.7.1	R.m.s based method	21
2.7.2	Mean comfort standard method	23
2.7.3	Mean comfort complete method	24
2.8	Legislation and standards	24
2.8.1	ISO 2631-1	25
2.8.2	ISO 10056 (2001)	26
2.8.3	ENV 12299 (2009)	27
2.9	Summary	28
CHAPTER 3	RESEARCH METHODOLOGY	29
3.1	Introduction	29
3.2	Research methodology structure	30
3.3	Theoretical framework	31
3.4	Study design and population	31
3.4.1	Data Collection	31
3.4.2	Route	32
3.4.3	Vehicle	33
3.5	Design of experiment	34
3.6	Data collection	36
3.6.1	Human vibration meter (HVM 100)	37
3.6.2	Seat pad accelerometer	37
3.6.3	Tri-axial accelerometer	38
3.7	Procedure of measurement	39
3.7.1	Measurement location	39
3.7.2	Measurement direction	41

3.7.3	Frequency weighting	44
3.7.4	Mounting the accelerometers	44
3.7.5	Measurement duration	45
3.8	BLAZE data analysis software	46
3.9	Subjective Assessment	46
3.9.1	Questionnaire	47
3.9.2	Pilot test	47
3.9.3	Analytical method study	48
3.9.4	Population and sample size	49
3.10	Objective Assessment	50
3.11	Summary	50
CHAPTER 4	RESULTS AND DISCUSSION	52
4.1	Introduction	52
4.2	Assessment of whole body vibration level on train passenger	53
4.2.1	Route Ampang to Chan Sow Lin	54
4.2.2	Route Chan Sow Lin to Sentul Timur	56
4.2.3	Route Chan Sow Lin to Sri Petaling	58
4.3	Train ride comfort evaluation (N_{MV})	60
4.3.1	Route Ampang to Chan Sow Lin	60
4.3.2	Route Chan Sow Lin to Sentul Timur	61
4.3.3	Route Chan Sow Lin to Sri Petaling	62
4.3.4	Comparison train ride comfort between route	63
4.4	Passenger ride comfort assessment(N_{ND} and N_{VA})	64
4.4.1	Route Ampang to Chan Sow Lin	64
4.4.2	Route Chan Sow Lin to Sentul Timur	65
4.4.3	Route Chan Sow Lin to Sri Petaling	66
4.4.4	Comparison passenger ride comfort between route	67
4.5	Seat Amplitude Transmissibility (SEAT)	68

4.5.1	Comparison SEAT between route	71
4.6	Questionnaire result and analysis	72
4.6.1	Demographic	72
4.6.2	Correlation between vibration magnitude towards ride comfort	75
4.6.3	Correlation between vibration magnitude towards sedentary activity	77
4.6.4	Correlation between ride duration towards ride comfort	77
4.7	Summary	78
CHAPTER 5	CONCLUSION AND RECOMENDATION	80
5.1	Conclusion	80
5.2	Recommendation for future work	94
	REFERENCES	96
	APPENDICES	103

LIST OF TABLE

TABLE	TITLE	PAGE
2.1	Number of passenger for Light Rail Transit services,2013	5
2.2	Number of passenger for Light Rail Transit services,2014	6
2.3	Types of track vibration	9
2.4	Factor related to vibration source	9
2.5	Guide for the application of frequency-weighting curves for principal weighting	16
2.6	Axis multiplier and weighting filter according ISO 2631	16
2.7	Typical conditions for simulation of ride characteristic and comfort	21
2.8	Perception of ride comfort according to ISO 2631-1	22
2.9	Ride comfort level evaluation scale	22
2.10	N _{MV} evaluation scale	23
2.11	Major whole body vibration standards	24
2.12	Frequency weighting based on ISO 2631-1	25
2.13	Ride comfort index based ISO 2631-1	26
2.14	Motion quantities and measurement position for estimation of ride comfort	27
3.1	Technical information for Ampang to Sentul Timur	32
3.2	Track route between station from Ampang to Chan Sow Lin	32
3.3	Track route between station from Chan Sow Lin to Sentul Timur	33
3.4	Track route between station from Chan Sow Lin to Sri Petaling	33
3.5	Specifications of Ampang line EMUs	34
3.6	Frequency weighting table for ride comfort	44

3.7	Railway vibration characteristic	44
3.8	Section part of questionnaire	47
3.9	Result of Cronbach Alpha for study sample	48
3.10	Correlation value and interpretation	48
3.11	Interpretation of coefficient correlation size	49
3.12	The P-value	49
3.13	Table to determine population and sample size	49
4.1	Route of ride comfort assessment	53
4.2	Demographic of LRT respondent	73
4.3	Correlation between vibration magnitude and ride comfort	76
4.4	Correlation between vibration magnitude and sedentary activity	77
4.5	Correlation between duration and ride comfort	78

LIST OF FIGURE

FIGURE	TITLE	PAGE
2.1	Components of track	7
2.2	Simplified mechanical system representing human body standing a vertically platform	11
2.3	Sitting position	13
2.4	Health guidance caution zone	14
2.5	Influence from track, others physical factors and human factors on ride comfort and ride quality	20
3.1	Research methodology structure	30
3.2	Theoretical framework for assessment	31
3.3	EMUs for Ampang line	34
3.4	Ampang line track route	35
3.5	The schematics WBV data collection system	36
3.6	Larson Davis Vibration Meter (HVM 100)	37
3.7	Seat pad accelerometer	38
3.8	Tri axial accelerometer	38
3.9	Location of measuring point	40
3.10	Location of floor accelerometer for seating and standing,	40
3.11	Local references system for vehicle body	41
3.12	Local references system for a person in seated position	42
3.13	Seating position for assessment in LRT passenger	42
3.14	Local references system for a person in standing position	43
3.15	Standing position for assessment in LRT passenger	43
3.16	Accelerometers mounting guide	45
3.17	Review of blaze software	46
4.1	WBV value for seating position at route Ampang - Chan Sow Lin	54

4.2	WBV value for standing position at route Ampang - Chan Sow Lin	55
4.3	WBV value for seating position at route Chan Sow Lin - Sentul Timur	56
4.4	WBV value for standing position at route Chan Sow Lin - Sentul Timur	57
4.5	WBV value for seating position at route Chan Sow Lin - Sri Petaling	58
4.6	WBV value for standing position at route Chan Sow Lin - Sri Petaling	59
4.7	Train ride comfort index for route Ampang - Chan Sow Lin	60
4.8	Train ride comfort index for route Chan Sow Lin - Sentul Timur	61
4.90	Train ride comfort index for route Chan Sow Lin - Sri Petaling	62
4.10	Comparison of ride comfort index for Ampang line	63
4.11	Seating and standing ride comfort index for route Ampang - Chan Sow Lin	64
4.12	Seating and standing ride comfort index for route Chan Sow Lin - Sentul Timur	65
4.13	Seating and standing ride comfort index for route Chan Sow Lin - Sri Petaling	66
4.14	Comparison of ride comfort index for Ampang line route	67
4.15	Vibration dose value (VDV) by each track section	69
4.16	SEAT for Ampang line route	70
4.17	Passenger seat in Ampang line train	71
4.18	Comparison of SEAT value for each track section in Ampang line	71
4.19	LRT respondent gender	73
4.20	LRT passenger age	74
4.21	LRT passenger height	74
4.22	LRT passenger weight	75

LIST OF EQUATIONS

	TITLE	PAGE
2.1	Root mean square (R.M.S)	14
2.2	Vibration dose value (VDV)	15
2.3	SEAT A_w (%)	18
2.4	SEAT _{VDV} (%)	18
2.5	R.M.S ride comfort	22
2.6	Ride comfort level (RCL)	22
2.7	Mean comfort standard method	23
2.8	Mean comfort standard method X-axis	23
2.9	Mean comfort standard method Y-axis	23
2.10	Mean comfort standard method Z-axis	23
2.11	Mean comfort complete method (seating)	24
2.12	Mean comfort complete method (standing)	24

LIST OF SYMBOLS AND ABBREVIATIONS

SYMBOLS	-	ABBREVIATIONS
WBV	-	Whole body vibration
N_{mv}	-	Ride comfort index defined by statistical method
N_{VA}	-	Ride comfort index of seated position
N_{vd}	-	Ride comfort index of standing position
VDV	-	Vibration dose value
CF	-	Crest factor
r.m.s	-	Root mean square
W_k	-	Vertical vibration at the seat
W_d	-	Horizontal vibration at the seat
$a_w(t)$	-	Weighted acceleration translational
T	-	Duration of the measurement
m/s^2	-	Meter per second square
$m/s^{1.75}$	-	Meter per second power of 1.75
RCL	-	Ride comfort index defined by r.m.s based method in Korea and Japan
SPSS	-	IBM Statistical Package for Social Science
Hz	-	Hertz. Measurement to indicates frequency
W_z	-	Ride comfort index defined by Sperling's method
SEAT	-	Seat effective amplitude transmissibility
G	-	Double sided square acceleration
A_{rms}	-	Weighted r.m.s acceleration
B	-	Frequency weighting curve
AU	-	Route A Uptrack section
AD	-	Route A Downtrack section

BU	-	Route B Uptrack section
BD	-	Route B Downtrack section
CU	-	Route C Uptrack section
CU	-	Route C Downtrack section
ERL	-	Express Rail Link Sdn Bhd
RapidRail	-	Prasarana Rapid Rail Sdn Bhd
KTM	-	Keretapi Tanah Melayu Sdn Bhd
LRT	-	Light Rail Transit

LIST OF APPENDICES

APPENDIX	TITLE	PAGE
A1	Arms value for seating position at route Ampang - Chan Sow Lin	97
A2	Arms value for standing position at route Ampang - Chan Sow Lin	98
A3	Arms value for seating position at route Chan Sow Lin - Sentul Timur	99
A4	Arms value for standing position at route Chan Sow Lin - Sentul Timur	100
A5	Arms value for seating position at route Chan Sow Lin - Sri Petaling	101
A6	Arms value for standing position at route Chan Sow Lin - Sri Petaling	102
A7	Train floor vibration and ride comfort value for route Ampang - Chan Sow Lin	103
A8	Comparison of train floor vibration and ride comfort value for Ampang line	105
A9	Seating and standing ride comfort value for route Ampang - Chan Sow Lin	106
A10	SEAT value for each track section in Ampang line	108
A11	Comparison of seating and standing ride comfort value for Ampang line	110
A12	Comparison of SEAT value for Ampang line route	111
A13	Data collection sheet route Ampang - Chan Sow Lin for ride comfort assessment	112
A14	Data collection sheet route Chan Sow Lin - Sentul Timur for ride comfort assessment	113

A15	Data collection sheet route Chan Sow Lin - Sri Petaling for ride comfort assessment	114
B1	HVM graph for seating position in route Ampang - Chan Sow Lin	115
B2	HVM graph for standing position in route Ampang - Chan Sow Lin	116
B3	HVM graph for seating position in route Chan Sow Lin - Sentul Timur	117
B4	HVM graph for standing position in route Chan Sow Lin - Sentul Timur	118
B5	Train floor vibration magnitude for Uptrack section of the route Ampang - Chan Sow Lin	119
B6	Train floor vibration magnitude for Downtrack section of the route Ampang - Chan Sow Lin	120
B7	Train floor vibration magnitude for Uptrack section of the route Chan Sow Lin - Sentul Timur	121
B8	Train floor vibration magnitude for Downtrack section of the route Chan Sow Lin - Sentul Timur	122
B9	Train floor vibration magnitude for Uptrack section of the route Chan Sow Lin - Sri Petaling	123

CHAPTER 1

INTRODUCTION

1.1 Research background

A passenger using the public transportation system requires faster, safer and more comfortable system than others transportation medium. Train are popular among people who live in the city because of the better comfortability during short and long travel, door to door estimation time, punctuality of operation, fixed schedule and provides better facilities than any other transports. The needs and expectations of passenger to the train transportation is high than any public transportation. Riding comfort and other requirement relating to the comfort has become important factor in evaluating characteristic of transport (Suzuki, 1998). Ride comfort is essential in order to make railway service more comfortable transport. Concept of riding comfort were divided by two category of measurement. The first one is measurement of physical quantities that effect riding comfort and the others is measurement of the corresponding feelings of human beings. The riding comfort factors of railway vehicles is determined by various factors such as vibration, acoustic noise, humidity, temperature, smell, visual stimuli and seat design (Suzuki, 1998). Among of the various contributing factor, the vibration source from railway vehicle motion is taken as primary concern because its effect relatively large in railway vehicle (Y-G Kim, Won, Kim, Kim, & Kim, 2003).

The vibration characteristic of railway vehicle is complex because not only effected by condition of rolling stock itself such as wheel profiles, suspension, and other equipment but also effected by track irregularities, rail profile, cant, curvature and tilting condition (Cleon & Lauriks, 1996; Suzuki, 1998).

Vibration is complex because it is contain many frequency and effect of WBV exposure causes a complex distribution of oscillatory motion and forces within the body that led to discomfort sensation and health effect (2631-1, 1997). Usually WBV occurs in seated postures while people are driving the vehicle or passenger were used transportation system (Mansfield, 2005). Its appears that locomotive engineers and conductors are working in a unique environment with likely exposure to significant WBV and shocks depending on locomotive design, train speeds, and operational tasks (Christ, 1996; Sorainen & Rytönen, 2010).

WBV gained by human body increased when the duration of vibration exposure and total train trips experienced by the subject enlarged (Ismail & Nuawi, 2010). As the speed of the train increases the vibration magnitudes will also increase. Reducing the train speed can decrease the vibration exposure of the persons in the train but this will result in an increase in the travel time. Neither the railway line nor the passengers will like it (Birlick, 2009).

Furthermore, for evaluation ride comfort the passenger sensation and vibration characteristic is relatively. In addition, in term of train operation the frequent of train braking and accelerating are the major aspect that effect ride comfort. In addition, no international standards exist for the ride comfort because the dynamic characteristic of railway vehicle is different each country due to different vehicle, track and operational condition. As the result, the evaluation procedure of ride comfort is developed independently in each country (Y.-G. Kim, Choi, Kim, Kim, & Park, 2009).

Vibrational discomfort cause by various factors such as vehicle condition, track characteristics and operating condition can only be detected by special purpose vehicle in order to detect irregularity or corrugation of rail. In this researches, whole body vibration (WBV) exposure to the passenger that lead to the vibration discomfort when using the public transportation will be assess. The WBV exposure will be measured to assess the ride comfort among passenger in LRT using ride comfort index

Long term vibration stress can contribute to degenerative changes in the joints of the human body, especially in the lumbar spine and cause discomfort and health problem toward human body (Fritz.M., 2005). Among the preventive measures

suggested by EU directive, the periodical maintenance of the track and preventive maintenance of the train must be carried. Mean of frequency weighted acceleration are commonly use to evaluate vibration and jerks in respect to the comfort level in train (Khan & Sundström, 2004). (2631-1, 1997; Standard, 2001) commonly were used by train manufacturer and operator to carried the assessment to ensure vibration levels index in their range.

1.2 Problem statement

In Malaysia, there is no ride comfort assessment that could determine the quality of railway transportation service. The ride comfort assessment is important in order to monitor and maintain good services provided by railway operator to the customer. Moreover, excessive whole body vibration exposure in three different axis lead to discomfort sensation depends on area of exposure in passenger cannot be determined as the absent of ride comfort assessment. Identified problematic track section cannot be determined directly as the special purpose vehicle can only operate in non-operation hours. This situation led to inefficient works in order to detect track irregularity that effect ride comfort of passenger.

1.3 Objectives of research

The objectives are as follow:

- i. To determine the Seat Effective Amplitude Transmissibility (SEAT) of LRT.
- ii. To determine the correlation between vibration level and ride comfort.
- iii. Develop analytical analysis for identification of problematic track section.

1.4 Importance of research

This research outcome is to identify the WBV exposure in three different axis that led to discomfort sensation that feel by LRT passenger. In addition, track condition monitoring can be done while using in services train vehicle compare to the conventional method. From the measured data and analysis, the ride comfort of the

passenger is obtained and problematic track section area was determined for further action by LRT operator.

1.5 Scope of research

The scope of study has focused on several aspects as follows:

- i. Evaluation and assessment of WBV and ride comfort conducted at Ampang line LRT
- ii. Assesment Ride comfort of rail passenger based on ENV12299(2009) standard
- iii. All calculation and experiment guidelines conducted according ISO 10056 standard
- iv. Perception analysis of passenger ride comfort conducted using questionnaire
- v. The anlysis and calculation of the data used Blaze software, SPSS and Microsoft Excell.
- vi. Ride comfort data collection were done in empty train during non peak hour operation

1.6 Research outcomes

WBV exposure affect ride comfort index of LRT passenger in Ampang line. In addition, the work sample and standard of work based on site can be used as framework to evaluate the whole body exposure affect towards ride comfort of passenger in rail vehicle. In other hand, SEAT assessment show the efficiency of train seat passenger isolate the vibration magnitude lead to reducing of whole body vibration exposure. Based on analytical analysis, ride comfort index of passenger will determine and identification of problematic track section area can be detected.

CHAPTER 2

LITERATURE REVIEW

2.1 Introduction

The urban train in big city such as Prasarana (rapid rail), Express Rail Link (ERL) and Keretapi Tanah Melayu (KTM) they gives the transportation services to the people every day. The statistic table in Table 2.1 and Table 2.2 shows the increasing of passenger of LRT in the past two years. Increasing of passenger in every year put a challenged to the railway operator to meet the demand from the customer, at the same time the quality of service is a top priority. Railway operator need to work efficiently in order to reduce operation cost at the same time the quality provided to the customer is satisfying.

Table 2.1: Number of passenger for Light Rail Transits Services (Prasarana, 2013)

Type of services	First Quarter	Second Quarter	Third Quarter	Fourth Quarter
Kelana Jaya line	18,635,176	19,937,822	19,906,746	20,223,187
Ampang line	14,707,067	14,840,394	15,645,919	15,014,017
KL Monorail	6,140,853	6,186,464	6,448,065	6,662,241
KLIA Express	444,433	503,448	555,718	558,624
KLIA Transits	985,629	1,052,234	1,137,011	1,199,346

Table 2.2: Number of passenger for Light Rail Transits Services (Prasarana, 2014)

Type of services	First Quarter	Second Quarter	Third Quarter	Fourth Quarter
Kelana Jaya line	19,378,228	20,594,483	20,774,079	21,224,532
Ampang line	15,371,888	16,184,441	15,848,265	15,865,858
KL Monorail	6,186,372	6,041,153	5,486,658	6,589,283
KLIA Express	531,080	705,594	823,479	868,149
KLIA Transits	1,179,498	1,581,962	1,697,026	1,851,837

Railway vibration is the highest contributing factor to the ride comfort due to higher speeds and heavier loads. This faster and heavier trains give greater impact forces into the track and increase vibration levels within both track and train, thus will effect passenger safety, maintenance coast, and passenger comfort. (Connolly & Kouroussis, 2014). Other than that, railway machine equipment produce bigger dynamic load and noise if the source of vibration exceed allowed scope and that influence the equipment working and lifetime even more some parts will lose efficacy early.

The common issue of disorder and discomfort commonly related to WBV where the greater part of body weight is supported on vibrating surface, and the WBV commonly occur in vehicle and wheeled working machine like train (Tamrin et al., 2007).

2.2 Railway track

Railway track consist of various components such as railpad/fastening, sleeper, rail, ballast, subballast and subgrade which should guide the train along the track and trough the switches to the destination safely (Iwnicki & Dahlberg, 2006).

Figure 2.1 shows the components of the railway track used worldwide. Railway track function it's to guide the train with their wheelset that are rigidly connected to carry the load of the train and distribute the load over an area of the subgrade.

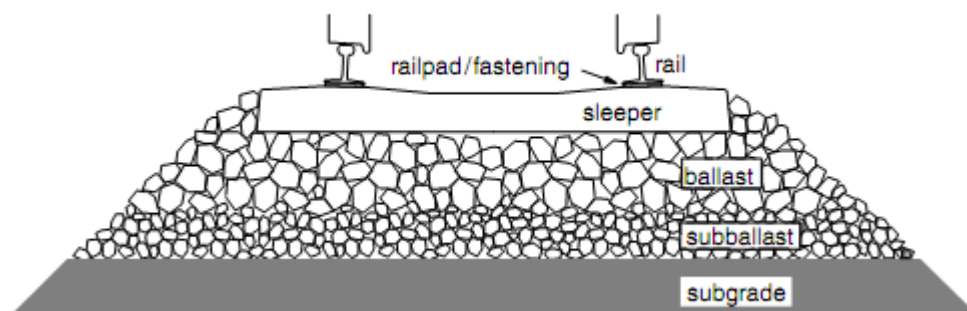

Figure 2.1: Components of track (Iwnicki & Dahlberg, 2006)

Dynamic phenomena will appear when train moves along the track especially at high speed. Faster and heavier trains induced ground vibration that transmitted to building along the railway lines. This cause discomfort to people due to noise and vibrations generated in the surrounding (Jonsson, 2000).

Railway generated noise and vibration generally become higher if the speed of train is increased. If the track support is built on soft ground (layer of clay) the speed of train must be limited because of train velocity may exceed the velocity of Rayleigh surface wave in the ground that cause increasing the vibration level. This situation happen in Swedish west coast line where the track had to be removed and the subground strengthened before the train were allowed to pass in high speed (Krylov, 2002).

2.2.1 Condition monitoring and track irregularity

First and foremost, condition monitoring of railway tracks is essential to ensuring the safety of the railways operation (Rolek, Bruni, & Carboni, 2015). Railways operation that operating according to the time table is not necessary to monitoring a parameter. However in services vehicle “probe vehicles” equipped with simple sensors and GPS may serve as probes to detect and analyze real time monitoring vehicle vibration while running in operation (Kojima, Tsunashima, & Matsumoto, 2006)

However, if track faults can be detected in-cabin, condition monitoring of track irregularities will be much easier. As the distinctive signal of track faults are hidden in natural frequency of car-body vibration, signal processing is necessary for the acceleration measured in-cabin to detect track faults. In other hand according to the

(H. Tsunashima, Naganuma, Matsumoto, Mizuma, & Mori, 2011; PF Weston, Roberts, Goodman, & Ling, 2006) several kinds of track faults can be detected by measuring the acceleration of bogies

Furthermore, condition of track have conventionally measure by exclusive vehicles that operates after services hours which consume time and cost. If the condition of track faults can detect by implementing of sensors in commercial running services vehicle, efficient and less time consuming of maintenance track would possible (Kojima, Tsunashima, Matsumoto, & Ogata, 2006).

In addition, as a rule, the track irregularities are measured during the safety and maintenance track controls, by means of certain specialized vehicles called track recording vehicles. Likewise, the monitoring of the track geometry implies other methods that basically rely on the vehicle dynamic response to the track irregularities (Hitoshi Tsunashima, Naganuma, & Kobayashi, 2014; P Weston et al., 2007)

Other than that, there is an alternative approach, widely used in the studies on the vehicle dynamics, consists in the introduction of the track irregularities in the numerical model as random data defined by the power spectral density (PSD) (Claus & Schiehlen, 1998; Li, Berggren, Berg, & Persson, 2008; Sharma, 2011; Suarez, Felez, Antonio Lozano, & Rodriguez, 2013; Zhou, Goodall, Ren, & Zhang, 2009). In this case, the track irregularities are not looked at as absolute values defined by distance, but they are represented as functions of wavelength or frequency

Track irregularity affect various aspect such as train operation stability, ride comfort, track structure diseases and ballast accumulated deformation, which increases risk of derailment increase intensely roll vibration and pitch vibration (Zhang, Jia, Wei, & Ru, 2015). Another source of vibration in track is Quasi-static that generated by the constant load of a train moving across the flexible soil track system (Hildebrand, 2001).

2.3 Vibration

Vibration is oscillatory motion. The extent of the oscillation determines the magnitude of the vibration and the repetition rate of the cycles of oscillation determines the frequency of the vibration (Griffin & Erdreich, 1991). The level of vibration in vehicle is major influences on the perception and comfort in rail travel in comparison with

other medium of transport (Iwnicki & Dahlberg, 2006). Moreover, according to the (Rao & Gupta, 1999) free vibration known as natural vibration which the object that vibrate under its own free natural condition such as classical simple pendulum as an example.

Other than that, according to (Connolly & Kouroussis, 2014) although railway lines generate vibration, but there are differences between train and track vibration characteristic. In addition, Table 2.3 shows types of track vibration characteristic based on type of train.

Table 2.3: Types of track vibration (Kouroussis, Connolly, Alexandrou, & Vogiatzis, 2015)

Types of train	Track Vibration characteristic
Underground trains	its generate vibration with higher frequency spectrum then over ground tracks
Urban tramways	Generate relatively amplitude vibration. Increasing in unsprung mass due to the more frequent deployment of low-floor vehicle has exacerbated vibration problem
Freight trains	Generate high amplitude and low frequency due to their low speed operation that can propagate to larger distances from the track
High speed trains	Generate elevated amplitude vibration due to their increased speeds. Vibration levels may become magnified if their speed become comparable to the wave speed in the supporting soil.

Table 2.4: Factor related to vibration source (Iwnicki & Dahlberg, 2006)

Factors Related to Vibration Source	
Factors	Influence
Vehicle suspension	If the suspension is stiff in the vertical direction, the effectiveness forces will be higher. On transits cars, only the primary suspension affects the vibration levels, the secondary suspension that supports the car body has no apparent effects.

Table 2.4 : (continued)

Wheel Type and Condition	Normal resilient wheels on rail transit system are usually too stiff to provide significant vibration reduction. Wheel flats and general wheel roughness are the major cause of vibration from steel wheel/steel rail system.
Track/Roadway Surface	Rough track are often the cause of vibration problem. Maintaining a smooth surface will reduce vibration levels.
Speed	As intuitively expected, higher speed result in higher vibration levels.
Depth of vibration source	There are significant differences in the vibration characteristic when the source is underground Compared to at the ground surface.
Transit Structure	The vibration levels from a lightweight bored tunnel will usually be higher than from a poured concrete box subway.
Track Support System	On rail systems, the track support system is one of the major component in determining the levels of ground borne vibration. The highest vibration levels are created by track that is rigidly attached to a concrete tracked. The vibration levels are much lower when special vibration control track system such as resilient fastener, ballast mats and floating slabs are used.

2.4 Effect of vibration magnitude and frequency towards train passenger

As magnitude of vibration is increased there is possibility increasing in discomfort. In addition, at low frequencies the force that acting on the human body is proportionally with the input of acceleration transmitted to the entire body (Griffin & Erdreich, 1991). Exposure of standing passenger from vibration magnitude at the floor may cause discomfort and magnitude-dependence of discomfort caused by lateral vibration at frequencies between 0.5 Hz and 16Hz (Thuong & Griffin, 2009). WBV will effects on human at the best may be discomfort and interference with activities at worst maybe injury or diseases. (M.Demic, J.Janjic, & Z.Milic, 2002)

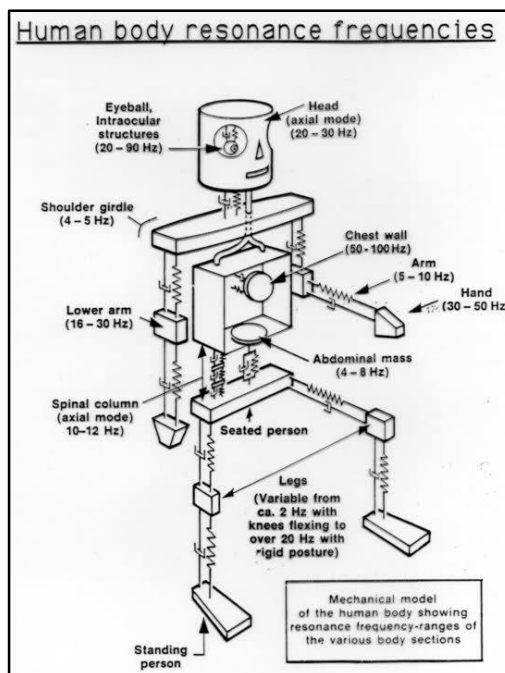

Figure 2.2: Simplified mechanical system representing the human body standing a vertically vibrating platform (Rasmussen, 1982).

Vibration in railway engineering encountered in various structural and mechanical application which generally affect due to suspension system, wheel profiles, track profiles, track irregularities, cant angle and curve radius (Y.-G. Kim et al., 2009). Table 2.4 shows the factors that influence the vibration in railway industries (Suhairy, 2000)

Vibration could also cause blurred vision, loss balance of body, and poor concentration (Azrah, Khavanin, Sharifi, Safari, & Mirzaei, 2014). Sometimes, frequencies and vibrating surfaces might cause permanent damages to internal organs, it is because each of organs in human body have their own resonance frequency as shown in Figure 2.2.

2.5 Non peak hour measurement

In railway operation, factors contributing to the ride discomfort during peak hour consist vibration discomfort, visual interference, loudness and thermal discomfort and etc. (Griffin & Erdreich, 1991). According to the (Altaian, 1975; Stokols, 1972), high density situations are not always perceived as crowded and it has been suggested that the perception of crowding is contingent upon several aspects of the situation. (Costa,

1984) speculate that the elevation in internal coach temperature due to the crowding condition because of dense containment of passenger lead to discomfort during peak hour. The combination and poor ventilation as responsible for health and discomfort problems on long journeys and on trains' stationary for extended periods (Cox, Houdmont, & Griffiths, 2006).

According to the previous research, the discomfort during peak hour were contributing by others factor than vibration such as visual interference, loudness, and thermal discomfort. Regarding to the previous research, the non-peak hour measurement is selected to running the research.

2.6 Whole body vibration (WBV)

The WBV involves the transmission on mechanical vibration to the human body in postures of standing an standing with frequency of concern ranging from 0.5 Hz to 80 Hz (2631-1, 1997). WBV will occur to the human if they were exposed to the shaking surface that supported their body where the vibration is come from the equipment then transmits to the human. For example, the vibration produced from train due to poor travelling track and poor maintenance of suspension of the train will transmitted from vehicle through seat where the human is supported. The vibration then will transmitted to the body and to the head. WBV can affect comfort, health and efficiency depending on exposure time, amplitude and type of waveform. Frequency ranges from 0.5 to 80 Hz are most common to whole vibration study.

In addition, intense occupational WBV exposure stemming from engines and vehicle has long been recognized as a contributor to early and accelerated spine disease and back pain (Bovenzi, Rui, & Negro, 2006). Accordingly, measurement of WBV should be conducted on the surface transmitting vibration to the human body (Lundstram & Holmlund, 1998). This because level of vibration depends on amount of viscous damping, structural damping of material and energy dissipation of dry friction between surface (Shabana, 1996). Figure 2.3 show the sitting position of whole body vibration. There are also safety concerns associated with WBV, vibration frequencies which match the resonant frequency of the body have been shown to hamper a worker's ability to perform job tasks (Paschold & Sergeev, 2009).

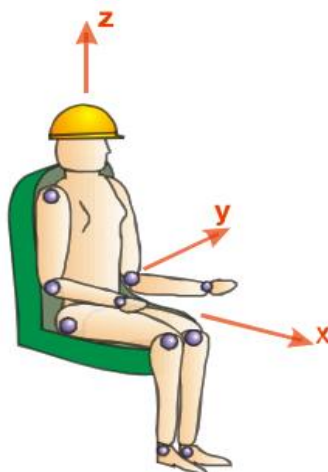

Figure 2.3: Sitting position (Griffin & Erdreich, 1991)

In railway perspective we cannot neglect vibrational source from various aspect as a major factor contribute to discomfort on railway passenger. According to the (Griffin & Erdreich, 1991) when the magnitude of vibration is increased there is usually an increase in discomfort. The vibration toward the body is dependent on the body posture. The effects of vibration are complex. The effect from that WBV for the human body as below;

- i. Caused discomfort,
- ii. Adversely effect on the performance
- iii. Potential for having back injuries
- iv. Having the health and safety risk

In addition, permanent exposure to WBV in prolonged working years might cause many health problems, including fixed damages to internal organs, muscles, joints, and bone structure, influencing on body and its different organs (Griffin & Erdreich, 1991; Mansfield, 2005; Sayed, Habashy, & Adawy, 2012). WBV that absorbed by human body will enhanced when the magnitude of vibration exposure experienced by passenger is increased. Moreover, Usually vibration factors from train cause by indelicate track passed by train, train operation style and speed of the train (Rasdan, 2011).

There is several debate according to the effect from body mass index towards passenger when exposed to the whole body vibration. According (Mortimer, M., Wiktorin, C., Pernold, G., Svensson, H., 2001) suggest there are possibilities of high BMI and effect towards LBP since spine must support greater weight of fat which

increase the pressure to the body structure lead to uncomfortable situation when execute activities. Other than that, according to the (Luoma, K., Riihimäki, H., Raininko, R., Luukkonen, R., Lamminen, A., & Viikari-Juntura, 1998), conclude that disk degeneration did not related with weight. In addition, according (Noorloos, Tersteeg, & Tiemessen, 2008) there is no significant risk were found in disk degeneration with increased BMI. Figure 2.4 shows health guidance zone of WBV towards health risk especially lumbar spine.

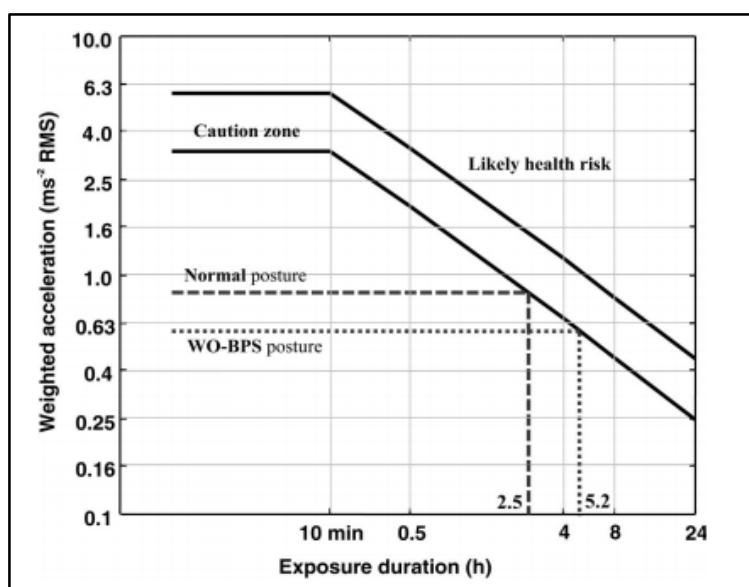

Figure 2.4: Health guidance caution zone (2631-1, 1997)

2.6.1 Root-mean-Square (r.m.s)

Root-mean-square (r.m.s) is the vibration magnitude that was expressed in terms of the frequency-weighted acceleration at the seat of seated person or in a feet of standing position. Its expressed in unit meters per second (m/s^2) for translational vibration and radians per second (rad/s^2) for rotational vibration (2631-1, 1997; Mansfield, 2005). The weighted r.m.s acceleration should be calculated in accordance with the following equation:

$$a_w = \left[\frac{1}{2} \int_0^T a_w^2(t) dt \right]^{\frac{1}{2}} \quad (2.1)$$

Where $A_w(t)$ is the vibration data and the average weighted vibration, in m/s^2 . T is time of measurement, in second.

2.6.2 Vibration dose value (VDV)

The vibration dose value (VDV) provide an alternative measure for vibration. The VDV is a quantity that is only applied to the whole body vibration measurements (Mansfield, 2005). The VDV method uses the fourth power of vibration magnitude, which more sensitive to the shocks than using square as in the r.m.s method calculation. The fourth power vibration dose value in meter per second to the power of 1.725 ($\text{m/s}^{1.725}$) or in radians per second to the power of 1.725 ($\text{rad/s}^{1.725}$). The VDV is measured by cumulative value meant that the numbers is directly proportional to the time. It is therefore important for any measurement of VDV to know the period over which the value was measured while VDV, which is a measure of dose of the vibration, allow more preference to shocks (Makhsous, Hendrix, & Crowther, 2005). According to the (2631-1, 1997), the VDV equation defined as:

$$VDV = \left[\int_0^T a_w^4(t) dt \right]^{\frac{1}{4}} \quad (2.2)$$

Where VDV is the vibration dose value in $\text{m/s}^{1.75}$ T is time of measurement in second.

2.6.3 Frequency and frequency weighting

A frequency weighting is a frequency response function that models the response of the body to the wave phenomena (Mansfield, 2005) Frequency is the number of times per unit second of vibrating body moves toward or backward. Usually used as value in cycles per second, mostly known as Hertz (Hz). Different frequency weighting are required for the different axes of vibration. In other hand, the manner in which vibration affects health, comfort, perception and motion sickness is dependent on the vibration frequency content (2631-1, 1997). There are two principal frequency weighting, related to health, comfort, and perception in Table 2.5 and Table 2.6.

Table 2.5: Guide for the application of frequency- weighting curves for principal weighting (2631-1, 1997)

Frequency weighting	Health	Comfort	Perception	Motion sickness
W_k	i. z-axis, seat surface	ii. z-axis, seat surface iii. z-axis, standing vertical recumbent (except head) iv. x-, y-, z-axes, feet (sitting)	v. z-axis, seat surface vi. z-axis, standing vertical recumbent (except head)	-
W_d	vii. x-axis, seat surface viii. y-axis, seat surfaces	ix. x-axis, seat surfaces x. y-axis, seat surfaces xi. x-, y-axes, standing horizontal recumbent xii. y-,z-axes, seat back	xiii. x-axis, seat surfaces xiv. y-axis, seat surfaces xv. x-, y-axes, standing horizontal recumbent	-
W_f	-	-	-	Vertical

Table 2.6: Axis multiplier and weighting filter according ISO 2631-1 (1997) (Nastac & Picu, 2010).

Position	Application	Measurement location	Axis	Axis multiplier	
Seated	Health	Seat pan	X	1.4	
			Y	1.4	
			Z	1	
	Comfort	Seat pan		X	1
				Y	1
				Z	1
		Seat back		X	0.8
				Y	0.5
				Z	0.4
		Floor		X	0.25
				Y	0.25
				Z	0.4

Table 2.6 : (continued)

	Perception	Seat pan	X Y Z	1 1 1
Standing	Comfort	Floor	X Y Z	1 1 1
	Perception	Floor	X Y Z	1 1 1
Recumbent	Comfort	Under pelvis	X Y Z	1 1 1
	Perception	Floor	X _{note a} Y _{note b} Z _{note b}	1 1 1
Notes a: ISO 2631-1 uses term “vertical” rather than “x-axis” b: ISO 2631-1 uses term “horizontal” rather than “y or z-axis”				

2.6.4 Seat effective amplitude transmissibility (SEAT)

The SEAT value is the ratio of the vibration experienced on top of the seat and the vibration exposed when sitting directly on the vibrating floor. Usually SEAT values used to determine the vibration isolation efficiency of a seat (Griffin & Erdreich, 1991). The SEAT values consist three important factor for seat dynamic performance which is vibration spectrum, transmissibility, and human response frequency weighting (Mansfield, 2005).

SEAT value of 100% indicates that the dynamic properties of the seat did not improve or reduced the ride comfort of the seat. if the SEAT value is higher than 100% this indicates that the ride comfort is worse in the seat than the floor, but if the value of seat is below than 100% this indicates that the dynamic properties of the seat is efficient in reducing the vibration (Mansfield, 2005).

SEAT will be calculated using specific formulae. The SEAT value provides information of vibration produce by train and transmit to the passenger. The calculation of SEAT value for A_w and VDV are:

$$SEAT \% = 100 \times \frac{r.m.s_{seat}}{r.m.s_{floor}} \quad 2.3$$

$$SEAT \% = 100 \times \frac{VDV_{seat}}{VDV_{floor}} \quad 2.4$$

In railway carriage, vibration is dominated by low frequency motion where conventional seat are unable to provide isolation from vibration. Therefore, even good railway seat might have a SEAT value greater than 100% (Mansfield, 2005).

2.7 Ride comfort

Ride comfort is a dynamic performance characteristic of railway vehicle and its affected by various factors such as temperature, noise, humidity, smell, and visual stimuli and vibrational but it's difficult to consider all factor simultaneously (Suzuki, 1998).in addition, ride comfort also a complex concept, in the analysis of railway vehicle dynamic its considered an essential element. Other than that, comfort is a state of being relaxed and feel freedom from worry or disappointment, the act of consoling, giving relief in affliction. There also have a non-motion factor that become contributing factor to the ride comfort such as acoustic noise, arrangement of seat and illumination. However, there are some problem to established ride comfort index using non motion evaluation due to high cost and need a lot of data to process. For that reason, evaluation of ride comfort in term of vibration is still an effective methodology and can be accepted in railway industry (Y-G Kim et al., 2003).

The passenger comfort related to vibrations is vital importance among the variety factors involved in comfort evaluation. The quantity that is relevant to the vibration aspect of ride comfort is the acceleration that exposed to the passenger during the motion of railway vehicle. The perception of ride comfort depends on amplitude and frequency of the acceleration as well as on its direction (lateral y or vertical z) (Kardas-cinal, 2009) or in the other words is the ride quality is determined by the frequency contents in acceleration signals (Strandemar, 2005).

In addition, each organ in human body have their own frequency ranges that sensitive to the vibration and the exceed exposure of vibration will cause discomfort and health problem (Kardas-cinal, 2009). (International Organisation for

Standardization), 1997) provide vibration exposure range between 1-80 Hz frequency ranges in terms of comfort, fatigue, and health. Frequency from 5-6 Hz troubles the stomach and around 20 Hz affect the head and neck, human body is most sensitive to vertical vibration in the 4-8 Hz frequency range. This frequency studies incorporates weighted acceleration concepts to determine the comfort level based on ISO 2631-1.

Usually the poor ride comfort cause by vibrational factors that can be categorized as motion factors. In terms of motion factors there is a various quantities that affect the passenger perception of ride comfort which is track geometry (alignment and cant), track irregularities, vehicle characteristic and vehicle speed that generate motion quantities factors (Foerstberg, 2000).

Ride comfort assessment there also assessment on ride quality. The ride quality can be interpreted as the capability of the railroad vehicle suspension to maintain the motion in human range of comfort and within the range necessary to ensure the safety of cargo.(Gangadharan, Sujatha, & Ramamurti, 2004) .

Other than that, in order to evaluate the dynamic performance of the railway vehicle the ride quality and ride comfort along with the safety, vehicle stability and vehicle curve negotiation capability are the outmost criteria needed (Goodwin, 1987). In railway industry, in order to provide safe and convenient services of public transportation, various of ride comfort method had been develop independently by each country and there are also studies attempting to establish a correlation between the method of evaluation the comfort during vibration exposure (Chen & Li, 2010; Kang, Choi, & Choe, 2011; Kardas-cinal, 2009; Y-G Kim et al., 2003).

In railway vehicle, in order to evaluate the ride comfort, measurement of the feelings of passenger according to the vibration is important. It's because human feelings vary with the frequency of vibration. Therefore, a weighted vibration considering human feelings is needed to evaluate the ride comfort of railway vehicle (Griffin & Erdreich, 1991; Y-G Kim et al., 2003). The ride quality based on human evaluation of comfort involves not only motion quantities but also human interaction variable as shown in Figure 2.5.

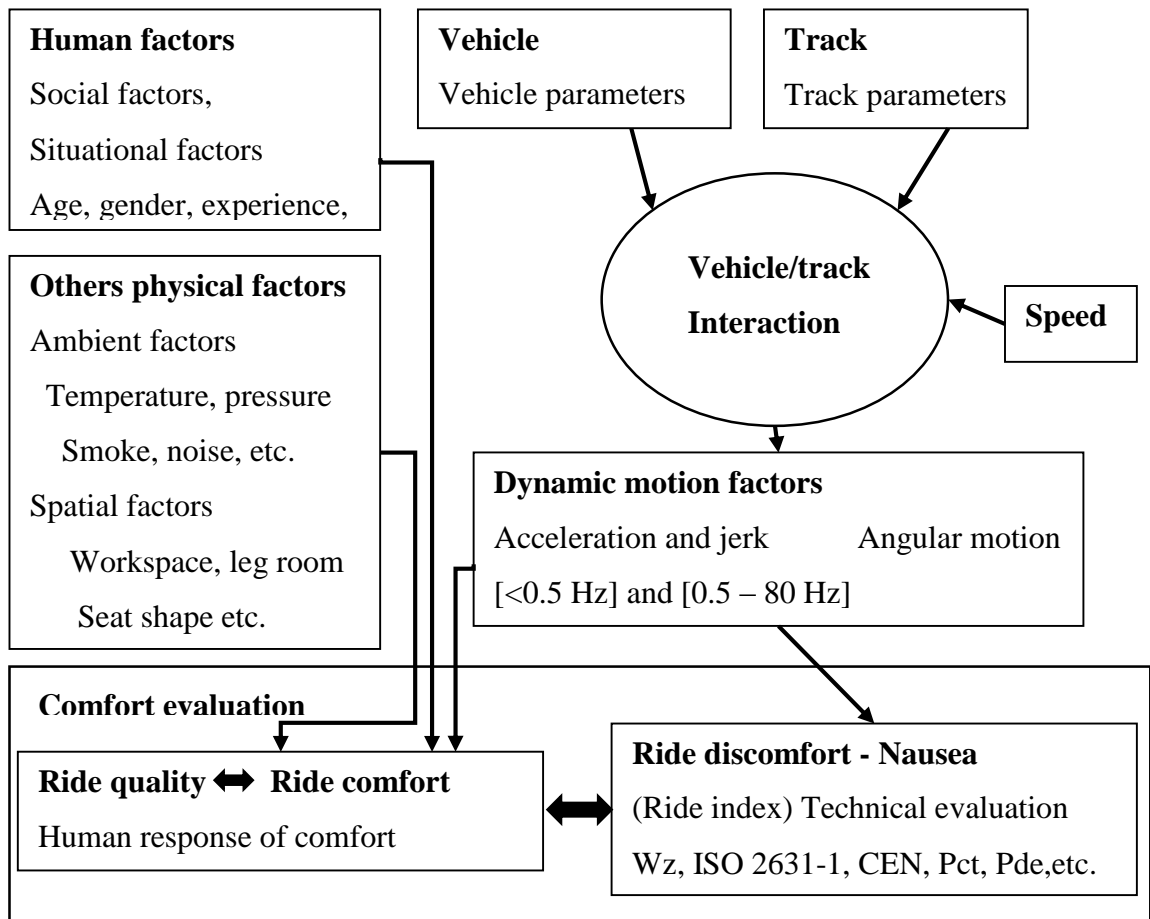

Figure 2.5: Influence from vehicle, track, other physical factors and human factors on ride comfort and ride quality (Iwnicki & Dahlberg, 2006)

In worldwide perspective, there is various standards or criteria are used to evaluate ride comfort. This is because the ride comfort is difficult to established universally because the characteristic of vibration of railway vehicle is different each country due to the different condition of vehicles, tracks and railways operation. As the result the ride comfort index has been developed independently by each country (Y-G Kim et al., 2003; Suzuki, 1998). According to the (Y-G Kim et al., 2003; Suzuki, 1998), there is several method used to evaluate ride comfort for railway vehicle which is r.m.s based method, Sperling's method, and statistical method. This method are basically used for long term ride comfort evaluation of railway vehicle. These three method use different evaluation procedure and frequency weighting curves. Typical condition for ride characteristic and ride comfort simulation evaluation as shown in Table 2.7.

According to the (Iwnicki & Dahlberg, 2006) it's difficult to definite assessment of the track quality, as the same vehicle demonstrate different track characteristic on different tracks.

Table 2.7: Typical conditions for simulation of ride characteristic and comfort

Input parameters	Recommended value or conditions
Track design	Straight track, curves with typical radius; optional comfort analysis in curve transitions (tilting trains)
Track irregularity	According to the specifications and conditions on the railway network; measured track irregularity if possible
Wheel- rail creep force law	Nominal profile of wheel and rail, nominal gauge; sensitivity analysis of gauge narrowing and widening, analysis of influence of worn wheel and rail profiles.
Wheel –rail creep- force law	Nonlinear theory, friction coefficient 0.4 (dryrail); analysis of influence of reduced friction coefficient 0.1 to 0.3 (wet rail)
Vehicle state	1. Intact 2. failure mode: airsprings deflated (for ride characteristic only)
Vehicle loading	Tare (empty)
Vehicle speed for ride characteristic	Maximum test speed (usually maximum service speed +10%)
Vehicle speed for ride comfort analysis	1. Maximum service speed 2. Speed of carbody pitch and bounce resonance

2.7.1 R.m.s based method

(International Organisation for Standardization, 1997) provides basic evaluation method based on crest factor. Weighted R.M.S. acceleration is basic evaluation method if crest factor is less than 9. Basic evaluation method uses frequency weighted r.m.s accelerations and is defined by:

$$A_{xj}^{Wi}, A_{yj}^{Wi}, A_{zj}^{Wi} = \left[\frac{1}{T} \cdot \int_{t-T}^T a_{wi}^2(t) dt \right]^{\frac{1}{2}} \quad (2.5)$$

Where $a_w(t)$ is the weighted acceleration as a function of time in meters per Second Square (m/s^2) T is the duration of the measurement, in seconds. As the ISO 2631-1 (1997), Table 2.8 gives approximate indications of likely reactions to various magnitudes of overall vibration values in public transport.

Table 2.8: Perception of ride comfort according to ISO 2631-1

r.m.s vibration level	Perception
Less than 0.315 m/s^2	Not uncomfortable
0.315 m/s^2 to 0.63 m/s^2	A little uncomfortable
0.5 m/s^2 to 1.0 m/s^2	Fairly uncomfortable
0.8 m/s^2 to 1.6 m/s^2	Uncomfortable
1.25 m/s^2 to 2.5 m/s^2	Very uncomfortable
Greater than 2 m/s^2	Extremely uncomfortable

ISO 2631-1 proposed to use r.m.s of the acceleration during arbitrary chosen time interval to evaluate the ride comfort of railway vehicles. Ride comfort level (RCL) is defined using the r.m.s.-based method by the equation:

$$RCL = 20 \log_{10} (A_{rms} / A_{ref}) \quad (dB) \quad (2.6)$$

Where A_{rms} is the weighted r.m.s acceleration, and A_{ref} is the reference acceleration which is $10^{-5} m/s^2$. From the r.m.s- based method the RCL were defined as approximate RCL scale in Korea and Japan (Y-G Kim et al., 2003) as shown in Table 2.9.

Table 2.9: RCL evaluation scale (Y-G Kim et al., 2003)

RCL in Korea (dB)	RCL in Japan (dB)	Ride Comfort
≤ 103	≤ 103	Very comfortable
103 -108	83 - 88	Comfortable
108 - 113	88 - 93	Medium
113 - 118	93 - 98	Uncomfortable
≥ 118	≥ 98	Very uncomfortable

2.7.2 Mean comfort standard method

The ride comfort indices according to the statistical method, N_{mv} , are calculated by means of the equations

$$N_{mv} = 6 \cdot \sqrt{(a_{XP95}^{wd})^2 + \sqrt{(a_{YP95}^{wd})^2 + \sqrt{(a_{ZP95}^{wd})^2}}}} \quad (2.7)$$

Where A_{95}^W is the 95 percentile from 60 weighted r.m.s values of acceleration, y is the lateral direction and z is the vertical direction. Table 2.10 shows that the evaluation scale according to the statistical method.

Table 2.10: N_{mv} evaluation scale

Evaluation scale, N_{mv}	Ride Comfort
$N_{MV} \leq 1,5$	Very comfortable
$1,5 \leq N_{MV} \leq 2,5$	comfortable
$2,5 \leq N_{MV} \leq 3,5$	Medium
$3,5 \leq N_{MV} \leq 4,5$	Uncomfortable
$N_{MV} \geq 4,5$	Very Uncomfortable

If the formula is to be used, for the measurement the value must be obtained from the center of the vehicle. Depending to the application, useful calculate the following partial comfort indexes:

$$N_{mvx} = 6 \cdot a_{XP95}^{wd} \quad (2.8)$$

$$N_{mvy} = 6 \cdot a_{YP95}^{wd} \quad (2.9)$$

$$N_{mvz} = 6 \cdot a_{ZP95}^{wd} \quad (2.10)$$

2.7.3 Mean Comfort Complete Method

Comfort formula for seated BS EN 12299 (2009)

$$N_{VA} = 4 \cdot (a_{ZP95}^{wb})^2 + 2 \cdot \sqrt{(a_{YA95}^{wd})^2 + \sqrt{(a_{ZA95}^{wb})^2 + 4 \cdot (a_{XD95}^{wc})^2}} \quad (2.11)$$

Comfort formula for standing BS EN 12299 (2009)

$$N_{VD} = 3 \cdot \sqrt{(a_{ZP50}^{wb})^2 + 4 \cdot \sqrt{(a_{YP50}^{wd})^2 + \sqrt{16(a_{XP50}^{wd})^2 + 5 \cdot a_{YA95}^{wd}}}} \quad (2.12)$$

2.8 Legislation and standards

The method to measurement of periodic, random and transient WBV will be referring to the (ISO, 2631-1: Mechanical vibration and shock-Evaluation of Human Exposure to whole body vibration-,1997) and for railway passenger comfort evaluation will be referring (ISO, 10056: Mechanical Vibration – Measurement and Analysis of Whole Body Vibration to which passenger and crews exposed in Railway vehicle 2001), and (ENV 12299: Railway Application – Ride comfort for passenger- measurement and evaluation, 1997). There were 150 human vibration standards about two decades ago (Aye & Heyns, 2011) Some of the standards used as show in Table 2.11.

Table 2.11: Major Whole Body Vibration Standards

International standards	Description
ISO 2631-1(1997)	Mechanical vibration and shock – Evaluation of human exposure to whole-body vibration. Part 1: General Requirements.
ISO 2631-2(1989)	Part 2: Continuous and shocks induced vibration in building (1 to 80Hz)
ISO 2631-4(2001)	Part 4: Guidelines for the evaluation of the effects of vibration and rotational motion on passenger and crew comfort in fixed-guide way transport systems
ISO 2631-5(2004)	Part 5: Method for evaluation of vibration containing multiple shocks

REFERENCES

- International Standards Organization. *Mechanical vibration and shock. Evaluation of human exposure to whole-body vibration. Part 1.* ISO 2631-1. 1997
- International Standards Organization. *Mechanical vibration and shock. Evaluation of human exposure to whole-body vibration. Part 4.* ISO 2631-4. 2001
- Altaian, I. (1975). The environment and social behavior. *Privacy, Personal Space, Territory, and Crowding.*
- Aye, S., & Heyns, P. (2011). The evaluation of whole-body vibration in a South African opencast mine. *Journal of the Southern African Institute of Mining and Metallurgy*, 111(11), 751-758.
- Azrah, K., Khavanin, A., Sharifi, A., Safari, Z., & Mirzaei, R. (2014). Assessment of Metro Passengers' Convenience While Sitting and Standing in Confrontation With Whole-Body Vibration. *International Journal of Occupational hygiene*, 6(4), 192-200.
- Beard, G. F., & Griffin, M. J. (2014). Discomfort of seated persons exposed to low frequency lateral and roll oscillation: effect of seat cushion. *Applied Ergonomics*, 45(6), 1547-57.
- Birlik, G. (2009). Occupational exposure to whole body vibration-train drivers. *Industrial Health*, 47(1), 5-10.
- Bovenzi, M., Rui, F., & Negro, C. (2006). An epidemiological study of low back pain in professional drivers. *Journals of Sound and Vibration*, 298(3), 514-539.
- British Standards Institution. *Railway Applications - Ride comfort for passengers - Measurement and evaluation.* London: BS EN 12299. 2009
- Chen, X., & Li, F. (2010). Evaluation model and empirical analysis of ride comfort of high-speed trains based on factor analysis and AHP. *Tiedao Xuebao/Journal of the China Railway Society*, 32(1), 13-18.
- Christ, E. (1996). European standardization in the framework of the machinery directive: aims and strategies. *Central European Journal of Public Health*, 4(1), 79-82.

- Claus, H., & Schiehlen, W. (1998). Modeling and simulation of railway bogie structural vibrations. *Vehicle System Dynamics*, 29(S1), 538-552.
- Cleon, L.-M., & Lauriks, G. (1996). Evaluation of passenger comfort in railway vehicles. *Journal of Low Frequency Noise & Vibration*, 15(2), 53–69.
- Connolly, D., & Kouroussis, G. (2014). Benchmarking railway vibrations—Track, vehicle, ground and building effects. *Construction and Building Materials*, 92, 64-81.
- Cooper, D., & Schindler, P. (2007). Business Research Methods, New Delhi McGraw Hill International Edition. *Statistics and Probability Series*.
- Costa, G. (1984). The Journey from home to the workplace: the impact on the safety and health of Workers / Commuters.
- Cox, T., Houdmont, J., & Griffiths, A. (2006). Rail passenger crowding, stress, health and safety in Britain. *Transportation Research Part A: Policy and Practice*, 40(3), 224-258.
- Dahlberg, T. (2006). 6 Track Issues. *Handbook of Railway Vehicle Dynamics*.
- Foerstberg, J. (2000). Ride comfort and motion sickness in tilting trains. *TRITA-FKT Report*, 2000, 28.
- Gangadharan, K. V., Sujatha, C., & Ramamurti, V. (2004). Experimental and analytical ride comfort evaluation of a railway coach. In *SEM ORG IMAC XXII Cont (pp. 1-15)*.
- Ghafar, A., & Najib, M. (2003). Reka bentuk tinjauan soal selidik pendidikan.
- Goodwin, M. J. (1987). Dynamics of railway vehicle systems. *Journal of Mechanical Working Technology*, 14(2), 245–247.
- Griffin, M. J., & Erdreich, J. (1991). *Handbook of Human Vibration. The Journal of the Acoustical Society of America* (Vol. 90).
- Grossoni, I., & Iwnicki, S. (2015). Dynamics of a vehicle–track coupling system at a rail join. *Proceedings of the Institution of Mechanical Engineers, Part F: Journal of Rail and Rapid Transit*, 229(4), 364-374.
- Hildebrand, R. (2001). Countermeasures against railway ground and track vibrations.
- Hussein, M. F. M. (2004). *Vibration from underground railways*. University of Cambridge.
- Ismail, A., & Nuawi, M. (2010). Whole Body Vibration Exposure to Train Passenger. *American Journal of Applied Sciences*, 7(3), 352-359.

- International Standards Organization, *Mechanical vibration — Measurement and analysis of whole-body vibration to which passengers and crew are exposed in railway vehicles*. ISO 10056, 2001.
- Iwnicki, S., & Dahlberg, T. (2006). *Handbook of Railway Vehicle Dynamics. System*. CRC press.
- Jonsson, J. (2000). *On ground and structural vibrations related to railway traffic*. Chalmers University of Technology,.
- Kang, J. S., Choi, Y.-S., & Choe, K. (2011). Whole-body vibration analysis for assessment of railway vehicle ride quality. *Journal of Mechanical Science and Technology*, 25(3), 577–587.
- Kardas-cinal, E. (2009). Comparative Study of Running Safety and ride railway vehicle." coordinates, 1(2) , 27.
- Khan, M., & Sundström, J. (2004). Vibration comfort in Swedish Inter-City trains—a survey on passenger posture and activities In *Proceedings of the 17th International Conference in Acoustic (ICA), Kyoto, Japan* (pp.3733-3736).
- Kim, Y.-G., Choi, S., Kim, S.-W., Kim, Y.-M., & Park, T.-W. (2009). an Experimental Study on the Ride Comfort of the Korean High-Speed Train. *Experimental Techniques*, 33(6), 30–37.
- Kim, Y.-G., Won, H.-B., Kim, S.-W., Kim, C.-K., & Kim, T.-W. (2003). Correlation of ride comfort evaluation methods for railway vehicles. *Proceedings of the Institution of Mechanical Engineers, Part F: Journal of Rail and Rapid Transit*, 217(2), 73–88.
- Kojima, T., Tsunashima, H., & Matsumoto, a. (2006). Fault detection of railway track by multi-resolution analysis. *Computers in Railways X, 1*, 955–964.
- Kojima, T., Tsunashima, H., Matsumoto, A., & Ogata, S. (2006). Fault Detection of Railway Track from On-Board Measurement Data(1 st Report, Detection of Rail Corrugation). *Nippon Kikai Gakkai Ronbunshu C Hen(Transactions of the Japan Society Of Mechanical Engineers Part C)(Japan)*, 18(8), 2447-2454.
- Kouroussis, G., Connolly, D. P., Alexandrou, G., & Vogiatzis, K. (2015). The effect of railway local irregularities on ground vibration. *Transportation Research Part D: Transport and Environment*, 39, 17–30.
- Krylov, V. (2002). Effects of the embankment topography and track curvature on ground vibration boom from high-speed trains, In *Proceedings of the symposium EURO DYN2002, Munich, Germany, Grundmann and Schueller, Eds., Swetz & Zeitlinger, Lisse* (pp.473-478).
- Li, M. X. D., Berggren, E. G., Berg, M., & Persson, I. (2008). Assessing track geometry quality based on wavelength spectra and track–vehicle dynamic interaction. *Vehicle System Dynamics*, 46(sup1), 261–276.

- Linacre, J. (1994). Sample size and item calibration stability.
- Luoma, K., Riihimäki, H., Raininko, R., Luukkonen, R., Lamminen, A., & Viikari-Juntura, E. (1998). Lumbar disc degeneration in relation to occupation. *Scandinavian Journal of Work, Environment & Health*, 358–366.
- Demic, M., Janjic, L., & Z.Milic. (2002). Some Aspects of the Investigation of Random Vibration Influence on Ride Comfort. *Journal of Sound and Vibration*, 253(1), 109–129.
- Makhsous, M., Hendrix, R., & Crowther, Z. (2005). Reducing whole-body vibration and musculoskeletal injury with a new car seat design, 48(9), 1183–1199.
- Mansfield, N. J. (2005). Human Response to Vibration.
- Mortimer, M., Wiktorin, C., Pernold, G., Svensson, H., V. (2001). Sports activities, body weight and smoking in relation to low-back pain: a population-based case-referent study. *Scandinavian Journal of Medicine & Science in Sports*, 11(3), 178–184.
- Narayanamoorthy, R., Saran, V., & Goel, V. (2008). Determination of activity comfort in Swedish passenger trains. In *Proceedings of 8th World Congress on Railway Research (WWCR 2008)*(pp.18-22).
- Nastac, S., & Picu, M. (2010). Evaluating methods of whole-body-vibration exposure in trains. *Ann. "Dunarea De Jos" Univ. Galati, Fasc. XIV Mech. Eng*, 55-60.
- Noorloos, D., Tersteeg, L., & Tiemessen, I. (2008). Does body mass index increase the risk of low back pain in a population exposed to whole body vibration? *Applied Ergonomics*, 39(6), 779-785.
- Rao, J., & Gupta, K. (1999). *Introductory course on theory and practice of mechanical vibrations*. New Age International.
- Rasdan, I. A. (2011). Comparative study of whole-body vibration exposure between train and car passengers: A case study in malaysia. *International Journal of Automotive and Mechanical Engineering (IJAME)*, 4, 490-503.
- Rasmussen, G. (1982). *Human body vibration exposure and its measurement*. Bruel and Kjaer.
- Razzaq, A., & Mustafa, M. (2012). Community capacity building for sustainable tourism development: Experience from Miso Walai homestay. *Community Capacity Building*, 2, 1-10.
- Rolek, P., Bruni, S., & Carboni, M. (2015). Condition monitoring of railway axles based on low frequency vibrations. *International Journal of Fatigue*.

- Rowntree, D. (1981). *Statistics without tears: A primer for non-mathematicians*. Scribner Book Company.
- Sayed, M. El, Habashy, S., & Adawy, M. El. (2012). Evaluation of Whole-Body-Vibration Exposure to Cairo Subway (Metro) Passengers. *International Journal of Computer Applications*, 55(8).
- Sekaran, U. (2006). *Research methods for business: A skill building approach*.
- Shabana, A. (1996). Resonance conditions and deformable body co-ordinate systems. *Journal of Sound and Vibration*, 192(1), 389-398.
- Sharma, R. (2011). Parametric analysis of rail vehicle parameters influencing ride behavior. *International Journal of Engineering, Science and technology*, 3(8), 54-56.
- Sorainen, E., & Rytönen, E. (2010). Whole-body vibration of locomotive engineers. *American Industrial Hygiene Association Journal*, 60(3), 409–11.
- Stokols, D. (1972). A social-psychological model of human crowding phenomena. *Journal of the American Institute of Planners*, 38(2), 72-83.
- Strandemar, K. (2005). *On Objective Measures for Ride Comfort Evaluation*. KTH.
- Suarez, B., Felez, J., Antonio Lozano, J., & Rodriguez, P. (2013). Influence of the track quality and of the properties of the wheel–rail rolling contact on vehicle dynamics. *Vehicle System Dynamics*, 51(2), 301–320.
- Suhairy, S. a L. (2000). *Prediction of ground vibration from railways*. Swedish National Testing and Research Institute.
- Suzuki, H. (1998). Research trends on riding comfort evaluation in Japan. *Proceedings of the Institution of Mechanical Engineers, Part F: Journal of Rail and Rapid Transit*, 212(1), 61–72.
- Tamrin, S. B. M., Yokoyama, K., Jalaludin, J., Aziz, N. A., Jemoin, N., Nordin, R., ... Abdullah, M. (2007). The Association between Risk Factors and Low Back Pain among Commercial Vehicle Drivers in Peninsular Malaysia: A Preliminary Result. *Industrial Health*, 45(2), 268–278.
- Thuong, O., & Griffin, M. (2009). Frequency-dependence and magnitude-dependence of the vibration discomfort of standing persons exposed to lateral vibration. *44th UK Conference on Human Response to Vibration, Loughborough, United Kingdom*, (pp. 7-9).
- Tsunashima, H., Naganuma, Y., & Kobayashi, T. (2014). Track geometry estimation from car-body vibration. *Vehicle System Dynamics*, 52(sup1), 207–219.
- Tsunashima, H., Naganuma, Y., Matsumoto, A., Mizuma, T., & Mori, H. (2011). Japanese railway condition monitoring of tracks using in-service vehicle. In *5th*

IET Conference on Railway Condition Monitoring and Non-Destructive Testing (RCM 2011) (pp. 3A2–3A2). IET.

Van Niekerk, J. ., Pielemeier, W. ., & Greenberg, J. . (2003). The use of seat effective amplitude transmissibility (SEAT) values to predict dynamic seat comfort. *Journal of Sound and Vibration*, 260(5), 867–888.

Weston, P., Ling, C., Goodman, C., Roberts, C., Li, P., & Goodall, R. (2007). Monitoring lateral track irregularity from in-service railway vehicles. *Proceedings of the Institution of Mechanical Engineers, Part F: Journal of Rail and Rapid Transit*, 221(1), 89–100.

Weston, P., Roberts, C., Goodman, C., & Ling, C. (2006). Condition monitoring of railway track using in-service trains. In *Railway Conditioning Monitoring, 2006. The Institution of Engineering and Technology International Conference on* (pp. 26-31). IET.

Wiersma, W., & Jurs, S. (1985). *Educational measurement and testing*. Allyn & Bacon.

William, W. (2009). *Research methods in education*. Pearson Education India.

Zhang, X., Jia, L., Wei, X., & Ru, N. (2015). Railway track condition monitoring based on acceleration measurements. In *The 27th Chinese Control and Decision Conference (2015 CCDC)* (pp. 923–928). IEEE.

Zhou, J., Goodall, R., Ren, L., & Zhang, H. (2009). Influences of car body vertical flexibility on ride quality of passenger railway vehicles. *Proceedings of the Institution of Mechanical Engineers, Part F: Journal of Rail and Rapid Transit*, 223(5), 461–471.