

WEAR TESTING OF THE HERMeS THRUSTER

AIAA-2016-5025

George J. Williams and James H Gilland
Ohio Aerospace Institute, NASA GRC, Cleveland, OH 44142

Peter Y. Peterson
Vantage Partners LLC, NASA GRC, Cleveland, OH 44135

Hani Kamhawi, Wensheng Huang,
Drew W. Ahern, John Yim,
and Daniel A. Herman
NASA Glenn Research Center, Cleveland, OH 44135

Richard R. Hofer and Michael Sekerak
NASA JPL, Pasadena, CA 91109

52nd Joint Propulsion Conference

July, 2016



JPL



VPL



Outline

- **Background**
- **Objectives**
- **Overview**
 - Test Article
 - Test Configuration
- **Wear Test Segments**
- **Trends in data**
 - Deposition on BN
 - Performance
 - Pole Cover Wear
 - Other Wear
- **Summary**
- **Current Status**

Asteroid Redirect Robotic Mission (ARRM)

- 50 kW-class SEP spacecraft
- SEP Technology Demonstration Mission

Ion Propulsion System: High-power HET

- Heliocentric transfer from Earth to asteroid
- Orbit capture at asteroid
- Transfer to low-asteroid orbit
- Planetary-defense demonstration
- Departure and escape from asteroid
- Heliocentric transfer from asteroid to lunar orbit
- Insertion into a lunar distant retrograde orbit
- Pitch and yaw control throughout

Herman, D. et al., "The Ion Propulsion System for the Asteroid Redirect Robotic Mission," AIAA 2016-4824

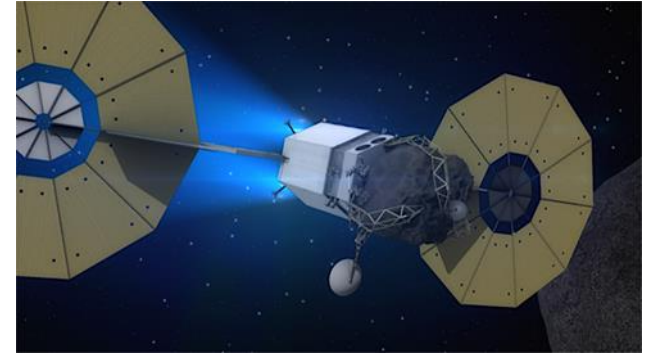

Artists conception of the ARRM spacecraft



12.5 kW HERMeS operation in VF-5 at GRC

Objective 1: Quantify wear trends over and extended period of TDU operation to identify unknown failure modes and support validation of service-life models

Objective/metric	Category	Measurement	Measurement Method	When
Component erosion	Primary	Surface height profile	Optical profilometry	Pre/post-test (pre/post-test segment)
Anomalous (visible) erosion	Primary	Digital images of TDU surfaces	Digital cameras	On-demand
Real-time assessment of B & C fluxes	Secondary	Relative density of sputtered atoms	Optical emission spectra	On-demand
Cathode depletion	Primary	Weight of insert	High-resolution balance	Pre/post-test
		Orifice Plate Temperature	Thermocouple	Continuous
Thermal deformation	Primary	TDU component temperatures	Thermocouple	Continuous
Emitter temperature	Secondary	HCA orifice plate temperature	Thermocouple	Continuous

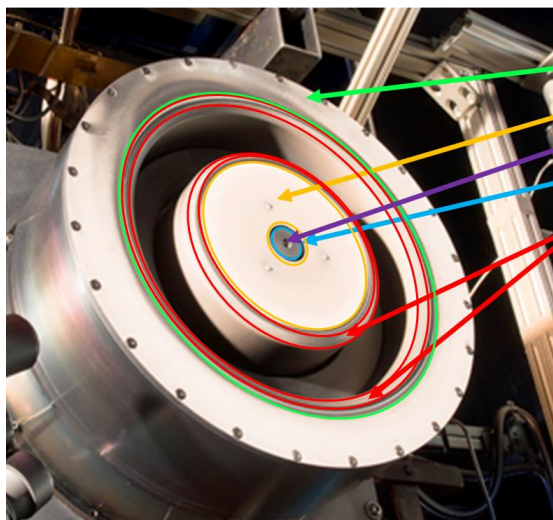

- Potential wear sites (& mitigation)**
- Outer pole cover (graphite covered)
 - Inner pole cover (graphite covered)
 - HCA orifice (orifice sizing)
 - HCA keeper (graphite)
 - Inner and outer discharge chamfers (magnetic shielding)

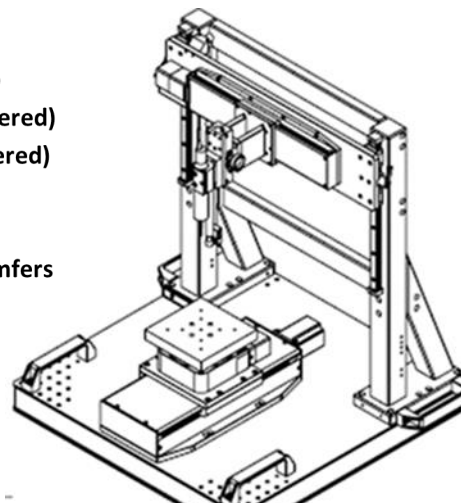

Nanovea chromatic profilometer



Wear Test Objectives



Objective 2: Quantify performance trends over and extended period of TDU operation to identify unknown failure modes and support validation of service-life models

Objective/metric	Category	Measurement	Measurement Method	When
Nominal Operating Point	Primary	Thrust	Calibrated thrust stand	Continuous
		Flow rate	Calibrated flow meters	Continuous
		Currents and Voltages	Calibrated shunts and probes	Continuous
		Thruster Telemetry (stability)	IVB sweep	At regular intervals
Ref. Operating Points	Primary	<i>As with nominal point</i>	<i>As with nominal point</i>	At regular intervals
Plume characterization	Primary	Ion current density	Faraday probe on probe arm	At regular intervals
		Ion energy distribution	RPA on probe arm	At regular intervals
		Electron Temp. & Plasma Pot.	Langmuir probe on probe arm	At regular intervals
		Charge-dependent current flux	ExB probe on probe arm	At regular intervals
Thermal trends	Primary	TDU component temps	Thermocouples	Continuous
	Tertiary	Anode and BN surface temps	IR camera	On demand
HCA emitter Temperature	Secondary	HCA orifice plate temperature	Thermocouple	Continuous
HCA insert health	Primary	Keeper IV trace for 3 mass flows	IV trace	At regular intervals
HCA plume mode onset	Secondary	A/C component of keeper voltage	IV trace	At regular intervals
TDU plume structure	Tertiary	Plume structure of Xe I and Xe II	Single-frequency images	On demand

Objective 3: Quantify deposition rate of back-sputtered facility material to identify the impact of deposition on thruster surfaces, to validate facility modeling, and to inform facility configuration for future tests.

Objective/metric	Category	Measurement	Measurement Method	When
Back-sputter rate	Primary	Mass of back-sputtered deposition	QCM	Continuous
Back-sputter composition	Primary	Mass-spec of deposition	SEM / XDAS	Post-test
Impact of deposition	Primary	Resistance at voltage/temperature	“Meggering”	Periodic
Spatially resolved sputter yields	Secondary	Thickness and composition of BSM	Witness plates	Post test

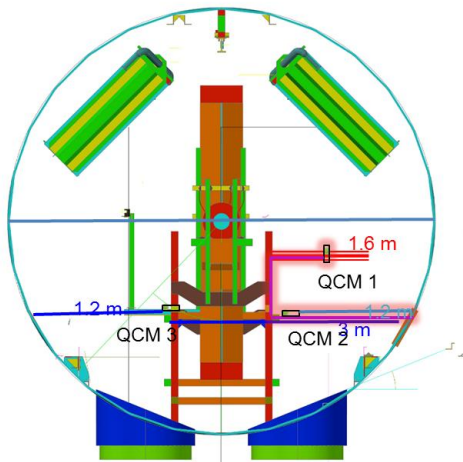

- Three QCMs near thruster plane
- Monitor horizontal, vertical symmetry of deposition
- Modeling predicts uniform flux at thruster position
- Long term diagnosis
 - Ta foil coupons on sides of panel
 - graphite nuts facing beam dump
 - Multiple (24) locations
 - Provide spatial (z, θ) resolution of total carbon deposition throughout tank

Objective 4: Provide guidance for future long-duration testing by identifying best practices and unknown issues associated with facility operation and configuration



HERMeS TDU-1 Status Entering Wear Testing



The HERMeS Technology Demonstration Unit One (TDU-1) has reached the level of maturity where long-duration wear testing is required

- **Extensive Performance Testing During 2015**
 - Demonstrated Nominal Performance Goals
 - Incorporated a Series of Minor Design Modifications
 - Correlated with Detailed Plasma Modeling of the Near-Feld Plume
- **Extensive Thermal and Structural Modeling Tied to Experimental Data**
- **High-confidence that a TDU-based design will meet ARRM thruster requirements**

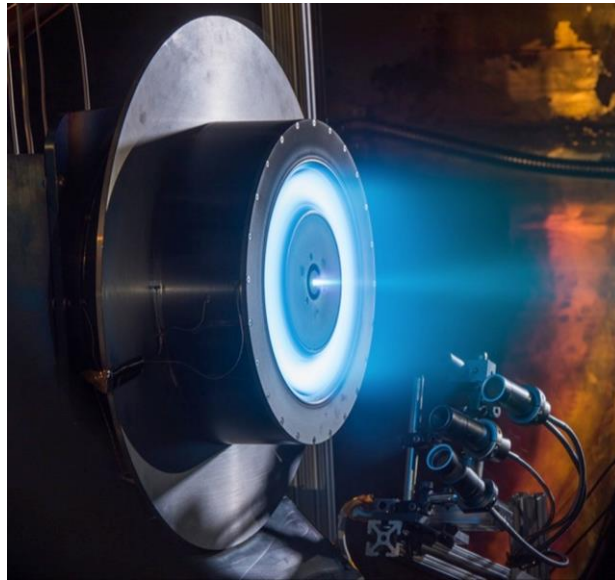

Kamhawi, H. et al., “Performance and Stability Characterization Tests of NASA’s 12.5-kW Hall Effect Rocket with Magnetic Shielding Thruster,” AIAA 2016-4826

Hofer, R. et al., “Development Status of the 12.5 kW HERMeS Hall Thruster for the Solar Electric Propulsion Technology Demonstration Mission,” AIAA 2016-4825

- All TDU-1 operation is in GRC's Vacuum Facility Five (VF-5)
 - Configuration identical to that of 2015 TDU performance testing base pressure $\sim 1 \cdot 10^{-7}$ Torr. Pressure near TDU $\sim 4.4 \cdot 10^{-6}$ Torr (Xe)
- Operation on laboratory power supplies/power console
- Operation on laboratory Xe feed system

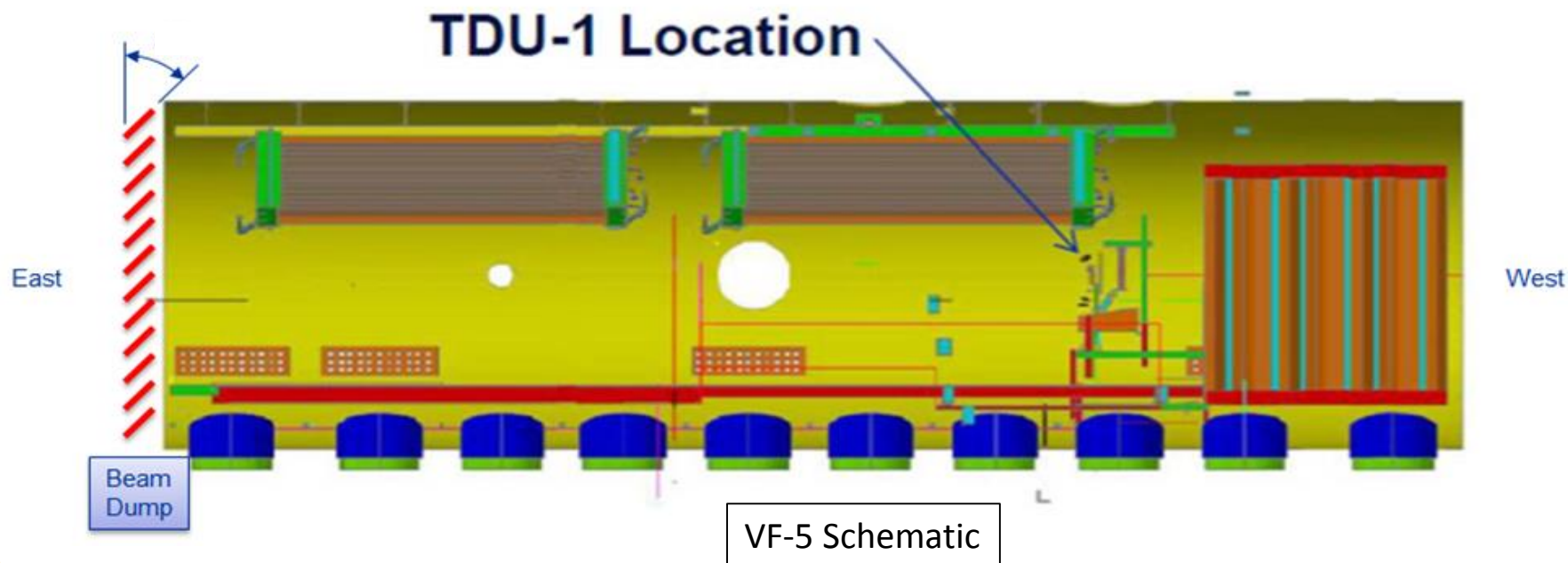







- Graphite paneling protects all surfaces downstream of thruster
- 10 degree and 30 degree angling of beam dump plates
- Aperture introduced for IR camera
- Beam dump can be biased as part of test-like-you-fly analysis/assessment



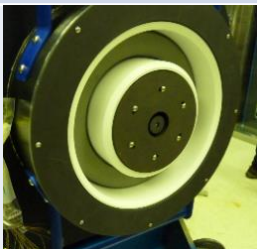

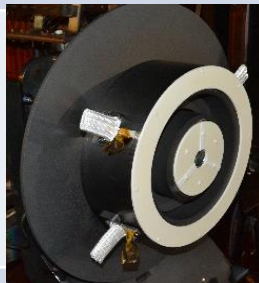
Wear Test Segments

Test Segment	I	II	III	IV (underway)
Objective particular to the Segment	Measure TDU performance with graphite pole covers	Measure erosion of graphite pole covers,	Measure erosion and performance with Al ₂ O ₃ pole covers	Measure erosion and performance over an extended period
Image				
Inner Pole Cover Configuration	Graphite, no masks, for 100 h No cover for 22 h	Polished graphite with Mo masks	Alumina with alumina masks	Same pole cover as Segment II with graphite masks
Outer Pole Cover Configuration	Graphite, no masks, for 100 h No cover for 22 h	Same pole cover as segment I	Alumina with no masks	New, polished graphite with graphite masks
Electrical Configuration	Varied	Cathode-tied	Floating	Cathode-tied
Duration, h	122	246	360	~1272 (670 completed)
Time-on-HCA and BN at end of segment, h	122	368	728	~2000 (1398 completed)



Overview

- Configuration
 - Thruster body tied to cathode in segments I, II, and IV
 - Thruster body floated in segment III
 - Peterson, P. et al., “NASA HERMeS Hall Thruster Electrical Configuration Characterization,” AIAA 2016-5027
- Wear Test Operating Point
 - 600 V, 12.5 kW
 - Magnetic field settings determined by performance characterization in Segment I
 - Kamhawi, H. et al., “Performance and Stability Characterization Tests of NASA’s 12.5-kW Hall Effect Rocket with Magnetic Shielding Thruster,” AIAA 2016-4826
- Typical Values for Various Parameters (vary slightly with configuration)
 - J_b : 1.9 A ($\equiv 0$ during segment III)
 - J_d peak-to-peak: 14 A
 - V_d peak-to-peak: 12 V
 - V_{cg} peak-to-peak: 30 V

Magnetic shielding has yielded net deposition on BN channel—**no evidence of BN erosion**

- Deposition estimated to be $\sim 1 \mu\text{m}$ after 728 h (measured $< 1 \mu\text{m}$ for 360 h)
- Surface resistance measured at 35Ω
- No change in thruster performance noted over first 50 h during coating

BN witness plates confirm QCM measurements are mostly carbon

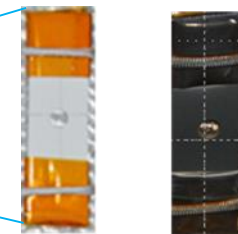
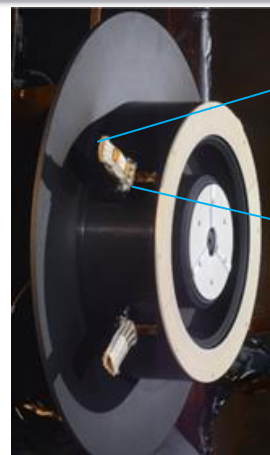

BN witness plate before and after 360 h

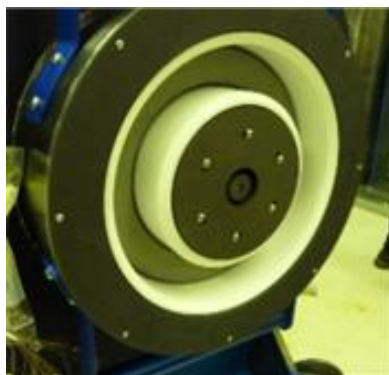

TDU-1 showing BN channel before testing and after 122 h

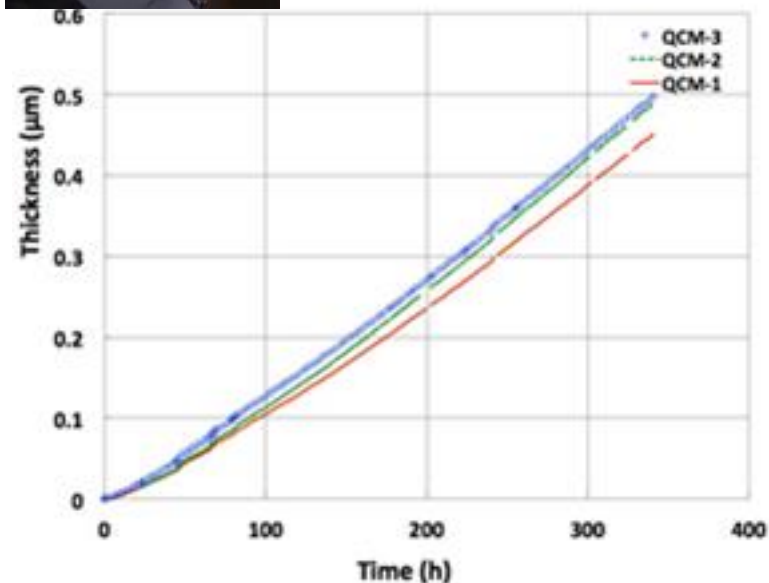

Gilland, J. et al., "Carbon Back-Sputter Modeling for Hall Thruster Testing," AIAA 2016-4941



Performance trends at 600 V, 12.5 kW

- Discharge current steady during wear testing
 - Manual flow control—**no changes required**
 - Variations observed are largely thermally-induced due to various restarts.
- Thrust also varies due to thermal drift, but is largely constant.
 - 3.4 % higher with graphite pole covers
- Total current also largely constant
 - Body current included in total current

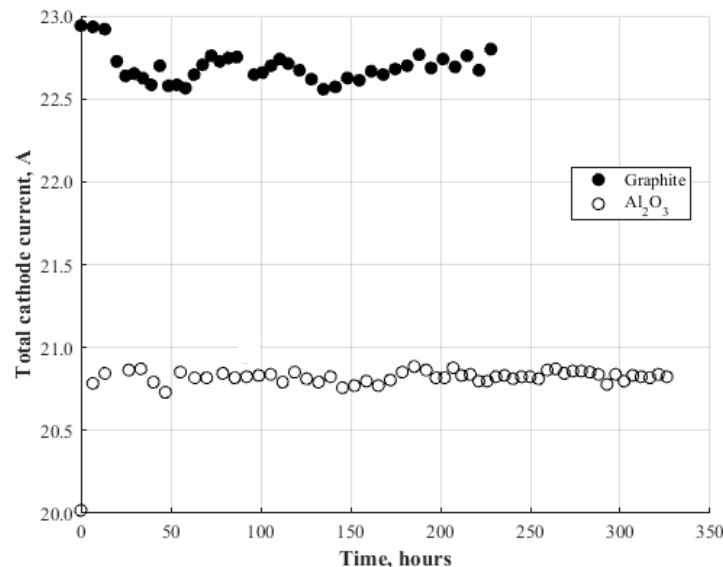
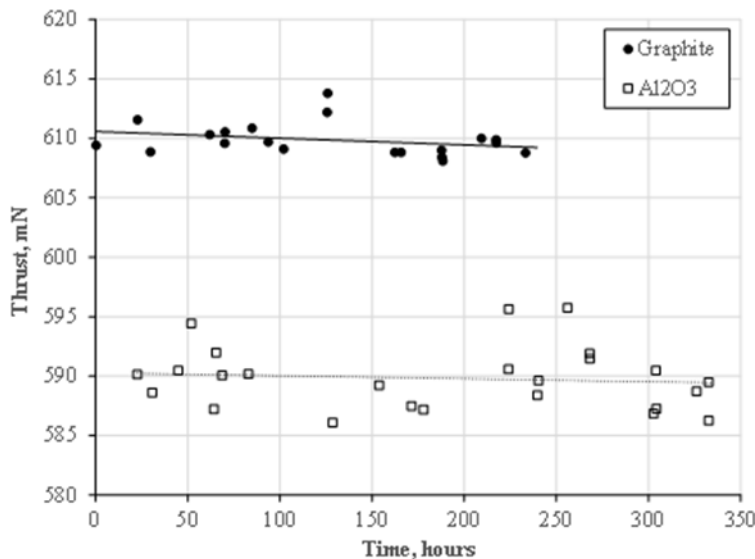
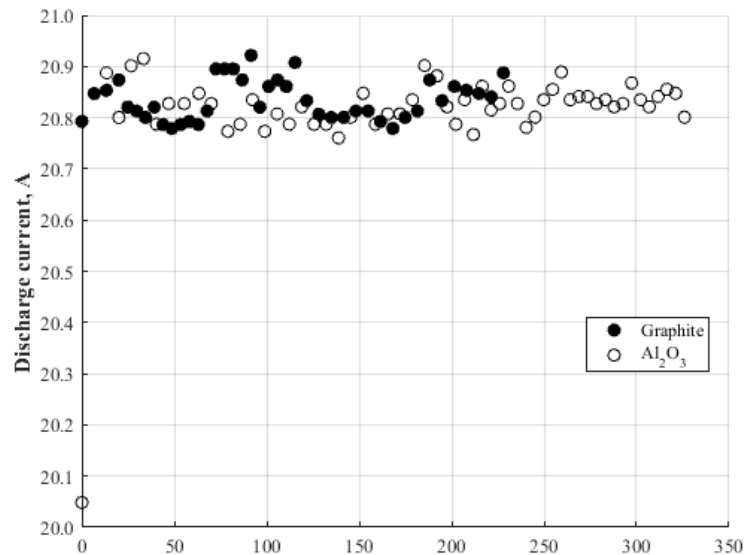

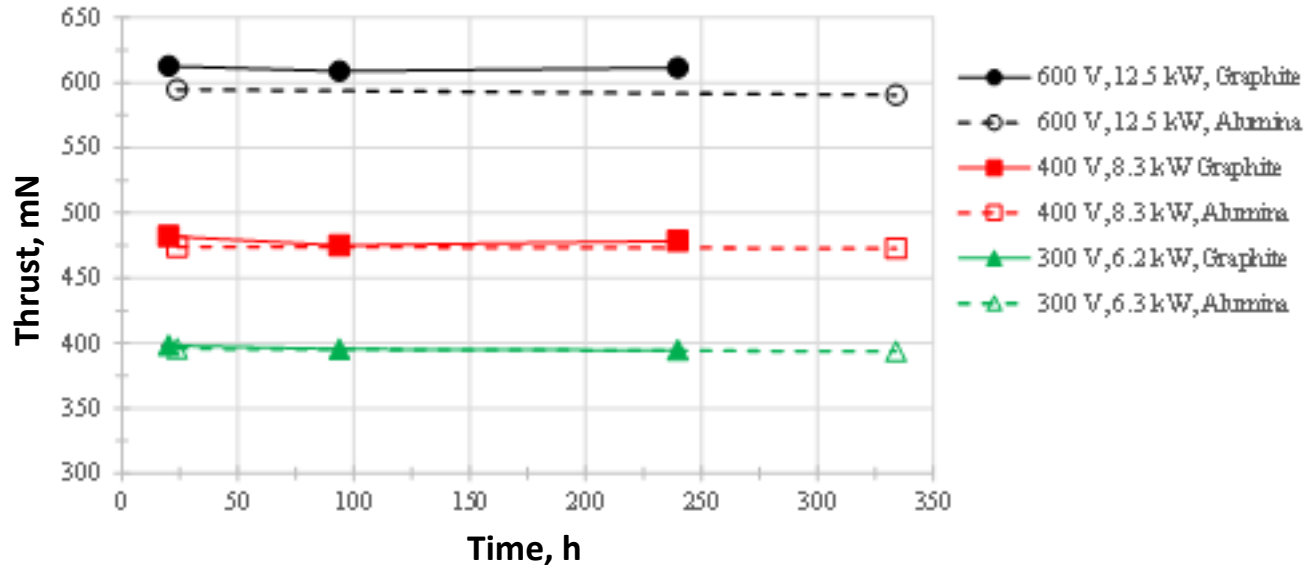

- Reference firing conditions measured periodically
 - Capture changes in performance for conditions other than the wear test operating point
- For 20.8 A, no changes observed in thrust with time for 300 V, 400 V, or 600 V operation.
- The slight improvement in performance at 600 V with graphite pole covers remains constant. No improvement at lower discharge voltages.

- Optical profilometry of inner front pole covers
 - Referenced to protected region under masks (Mo or Al_2O_3)
 - Two measurements at each radial location, each average over a bit
- Sputtered surface is textured, adds a few μm uncertainty
- Mo masks had Mo masks of their own
- Al_2O_3 masks were un-masked.

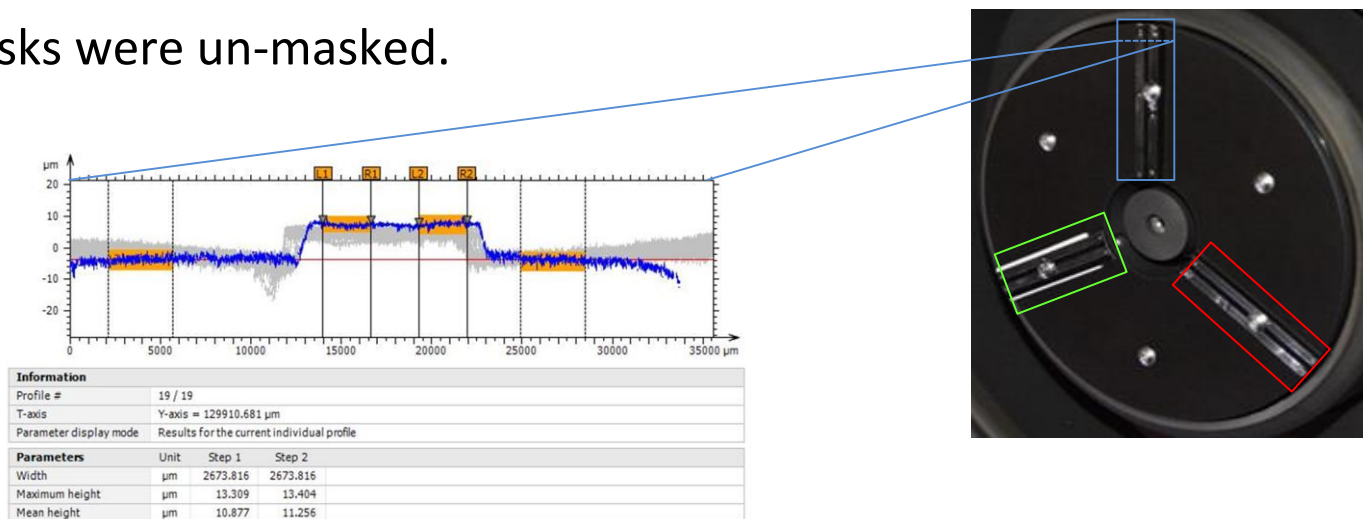



Sputter-erosion of graphite inner pole cover

- Graphite:
 - Erosion rate of 45 $\mu\text{m}/\text{kh}$
 - Maximize near edges
 - Nominal pole covers sufficient
- Molybdenum:
 - Maximum rate of 600 $\mu\text{m}/\text{kh}$
 - Appears to follow same trends...but doesn't!
- OES data suggest erosion increased between 20 and 75 h. Change in B-field at 20 h

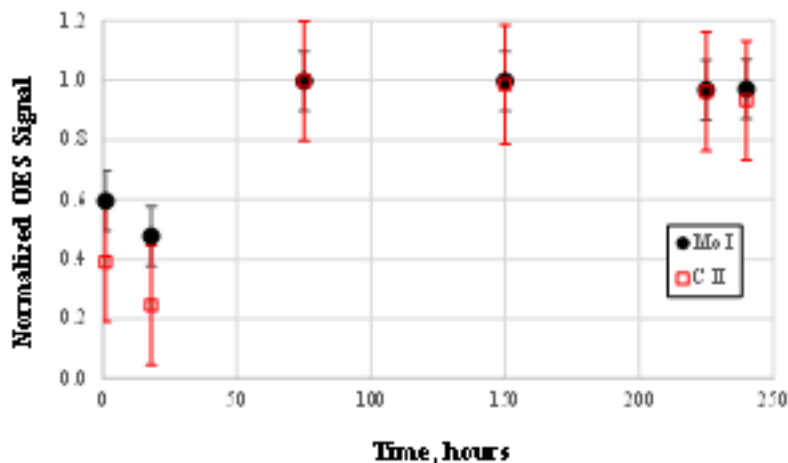
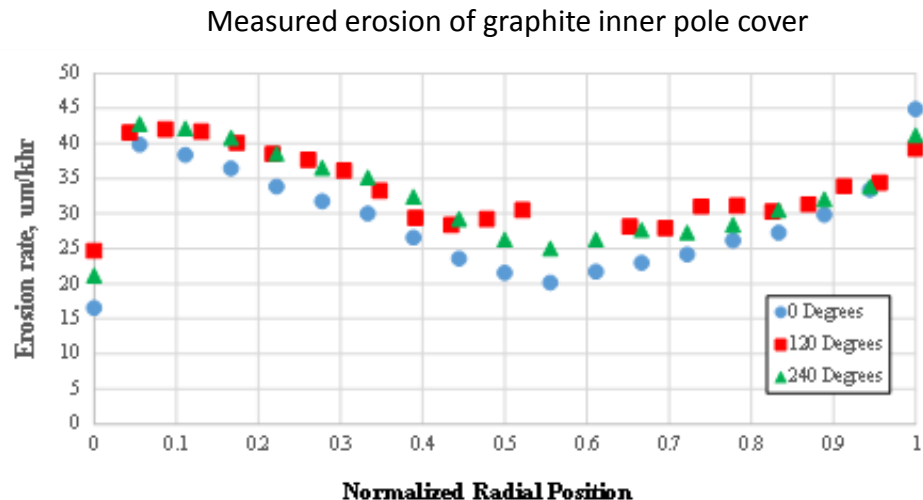

Mo and C OES signals from inner edge of inner pole cover

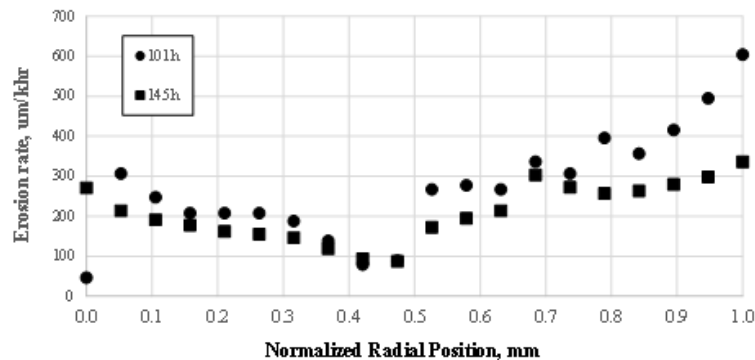

Measured erosion of Mo plates on inner pole cover 15

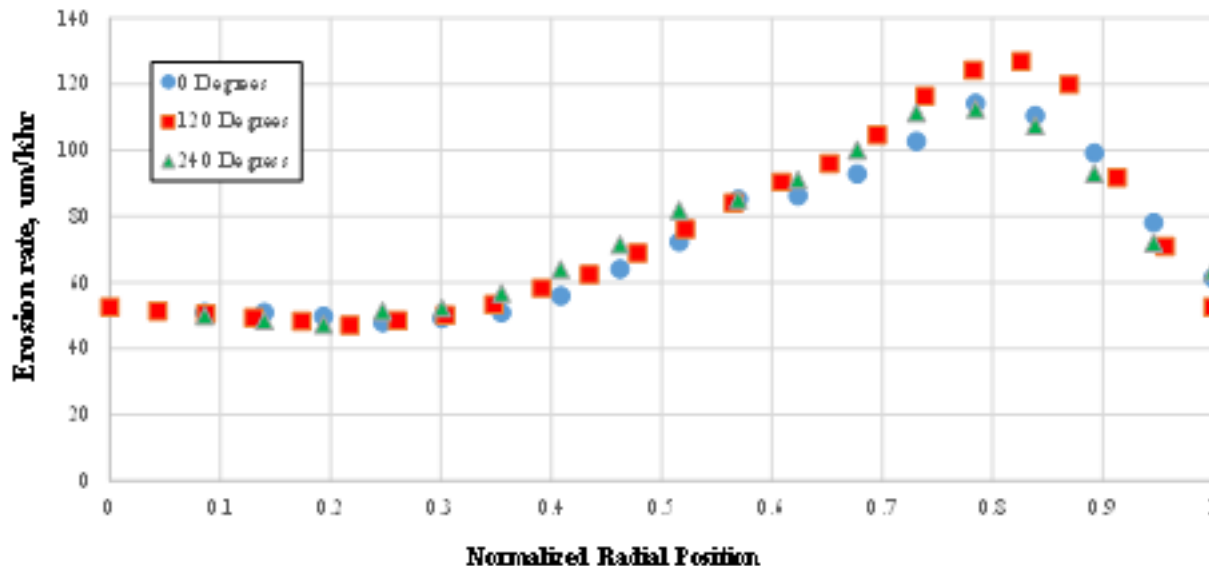

- Maximum Al_2O_3 rate of 135 $\mu\text{m}/\text{hr}$
 - Thick covers required to meet ARRM mission
- Fundamentally different erosion pattern
- OES data again suggest erosion was roughly constant (within uncertainty of measurement)

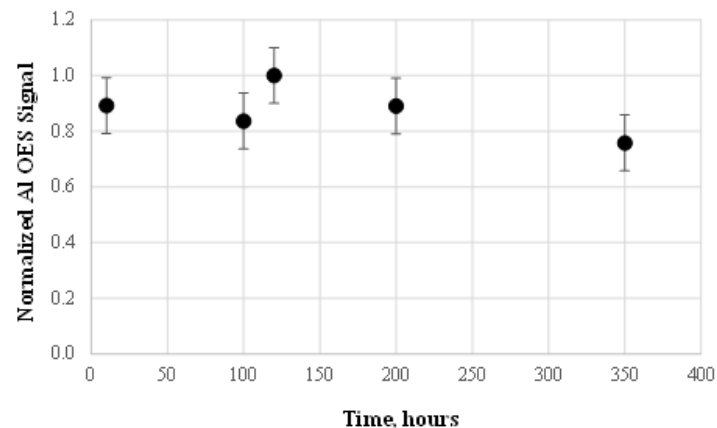

Al OES signal from inner edge of inner pole cover

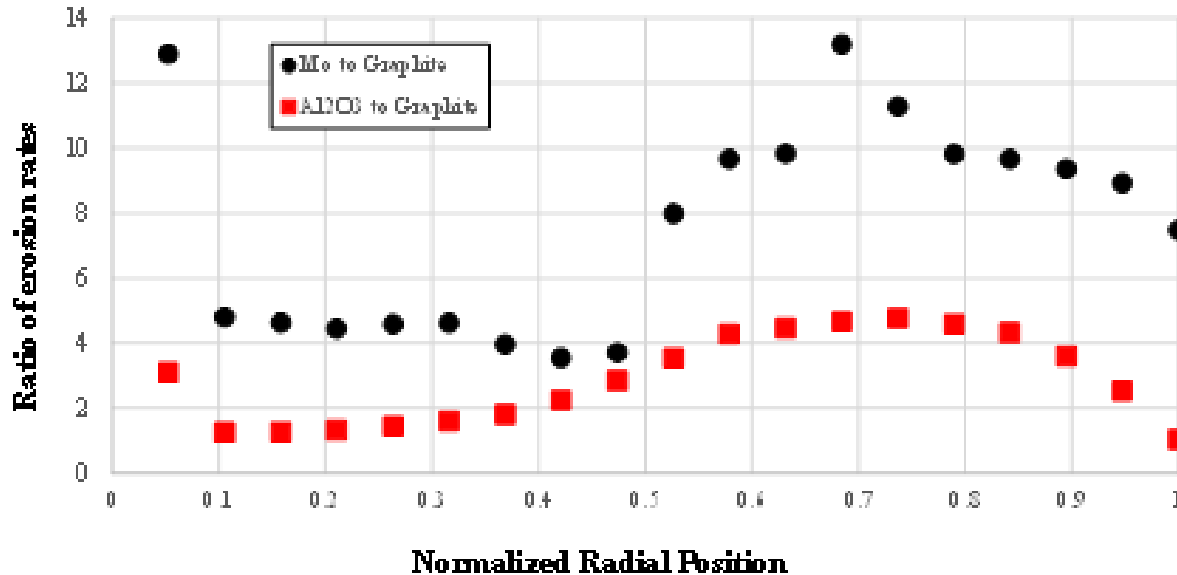

- Ratio of Mo and Al₂O₃ to graphite erosion rates
 - Intended to shed light on energy of sputtering ions
 - Reveals Mo and Al₂O₃ are eroding in similar regards wrt graphite (Mo rates being roughly 3x Al₂O₃ rates across the radius)
- Suggests erosion patterns are dominated by ions' angles of incidence rather than energy levels. (Cf. Oyarzabal, AIAA-2005-3525)
 - Ions between 75 eV and 125 eV
 - 15 degree variation in angle of incidence



Other Components

- Outer pole cover
 - Possible erosion observed near outer radius of graphite outer pole cover (44 $\mu\text{m}/\text{kh}$). Lack of reference (thruster not removed from chamber) makes absolute measurements difficult.
 - No erosion observed on the alumina outer pole cover—but no deposition either....
- Discharge cathode
 - No erosion observed on cathode keeper or orifice plate after 728 h (removed for inspection before Segment IV).
 - No change in ignition or cathode-only behavior observed.
 - [Verhey, T. et al., “Overview of HERMeS Hollow Cathode Testing,” AIAA 2016-5026](#)



Summary

- Test Campaign
 - Three of four test segments completed
 - Extensive performance testing
 - Measurement of inner pole cover wear for two potential thruster configurations
 - Demonstration of magnetic shielding over extended operation
 - Segment IV underway incorporating lessons learned
- Component Wear
 - No BN channel erosion
 - Graphite pole cover erosion of 45 $\mu\text{m}/\text{kh}$ yields < 50% of the volumetric erosion of alumina (including outer pole cover).
 - OES appears to yield real-time assessment of rates..
- TDU Performance
 - No variation in performance observed with thruster operating time
 - Performance gain associated with graphite (conducting) pole / cathode-tied configuration could be significant for long duration missions



Current Status

- Back-sputter characterization
 - Back sputter rates of 1.8 $\mu\text{m}/\text{kh}$ measured by QCMs
 - No impact observed on thruster performance
 - Graphite paneling has significantly reduced back-sputter onto the thruster
- Data suggest best configuration
 - Graphite pole covers with body tied to cathode
 - Lower erosion
 - Better performance
 - Acceptably worse beam divergence and spread of higher energy ions
 - Segment IV initiated to identify unknown issues associated with this configuration over extended (> 1000 h) operation
 - Graphite covers, with body tied to cathode potential (cathode floats wrt ground)
 - 670 h to date
 - No variation in thruster performance.
 - No anomalies noted through external visual inspection