

Mission and Design Sensitivities for Human Mars Landers Using Hypersonic Inflatable Aerodynamic Decelerators

Tara P. Polsgrove
NASA Marshall Space Flight Center
Huntsville, AL 35812
256-544-1274
tara.polsgrove@nasa.gov

Herbert D. Thomas
NASA Marshall Space Flight Center
Huntsville, AL 35812
256-544-4493
herbert.d.thomas@nasa.gov

Alicia Dwyer Cianciolo
NASA Langley Research Center
Hampton, VA 23681
816-434-5306
alicia.m.dwyercianciolo@nasa.gov

Tim Collins
NASA Langley Research Center
Hampton, VA 23681
757-864-3113
timothy.j.collins@nasa.gov

Jamshid Samareh
NASA Langley Research Center
Hampton, VA 23681
757-864-5776
jamshid.a.samareh@nasa.gov

Abstract— Landing humans on Mars is one of NASA’s long term goals. NASA’s Evolvable Mars Campaign (EMC) is focused on evaluating architectural trade options to define the capabilities and elements needed to sustain human presence on the surface of Mars. The EMC study teams have considered a variety of in-space propulsion options and surface mission options. Understanding how these choices affect the performance of the lander will allow a balanced optimization of this complex system of systems problem. This paper presents the effects of mission and vehicle design options on lander mass and performance. Beginning with Earth launch, options include fairing size assumptions, co-manifesting elements with the lander, and Earth-Moon vicinity operations. Capturing into Mars orbit using either aerocapture or propulsive capture is assessed. For entry, descent, and landing both storable as well as oxygen and methane propellant combinations are considered, engine thrust level is assessed, and sensitivity to landed payload mass is presented. This paper focuses on lander designs using the Hypersonic Inflatable Aerodynamic Decelerators, one of several entry system technologies currently considered for human missions.

landers to Mars. Optimization of Earth-to-Mars transportation systems includes finding the right balance of launch manifests, orbital aggregation of elements, and Mars orbit capture strategies. This paper identifies the impacts of a variety of architecture options on the human Mars lander, and informs the higher-level optimization of the architecture.

This work was performed as part of NASA’s Evolvable Mars Campaign (EMC) study. The EMC is focused on evaluating architectural trade options with the goal of achieving a sustainable human presence on the surface of Mars in the decade of the 2030’s. [1] The EMC study teams have considered a variety of in-space propulsion options and surface mission options that would support a crew of four for a long duration stay. In each potential scenario a lander capable of delivering between 18 and 27 t of payload to the surface is required. [2] With 20 t payload delivery capability on each lander, a total of 4 landers would be required to support a long duration surface mission. Landers designed to carry 27t of payload to the surface would reduce the number of landers to three. Figure 1 shows an image of the four-lander 20t payload manifest on a common descent module.

TABLE OF CONTENTS

1. INTRODUCTION.....	1
2. EARTH DEPARTURE OPTIONS	2
3. MARS ARRIVAL OPTIONS	4
4. ENTRY DESCENT AND LANDING OPTIONS.....	5
5. RESULTS.....	6
6. CONCLUSIONS.....	7
REFERENCES.....	8
BIOGRAPHY	8

1. INTRODUCTION

Designing a human Mars mission architecture requires a complex optimization of many different interdependent systems. Choices about Mars surface operations and equipment affect lander configuration and mass, which in turn affects in-space transportation systems that deliver those



Figure 1. Notional 20 t Payload Manifest

The Mars lander is comprised of three major pieces: the aerodynamic decelerator, the Mars descent module, and the payload that is delivered to the surface. The integration of these three pieces is highly dependent on the decelerator technology chosen. The reference lander design for EMC studies uses a Hypersonic Inflatable Aerodynamic Decelerator (HIAD) system to slow the vehicle in the Mars atmosphere and oxygen and methane supersonic retro

propulsion for final descent and landing. [3] An image of the 20t “Lander 2” configuration integrated with a HIAD is shown in in Figure 2. The HIAD Entry Descent and Landing (EDL) concept of operations is shown in Figure 3.

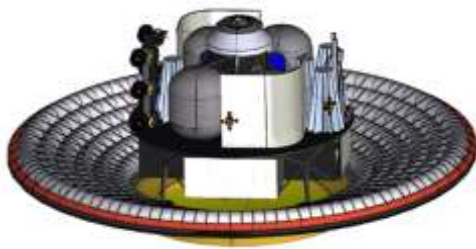

Figure 2. Human Mars Lander with HIAD deployed

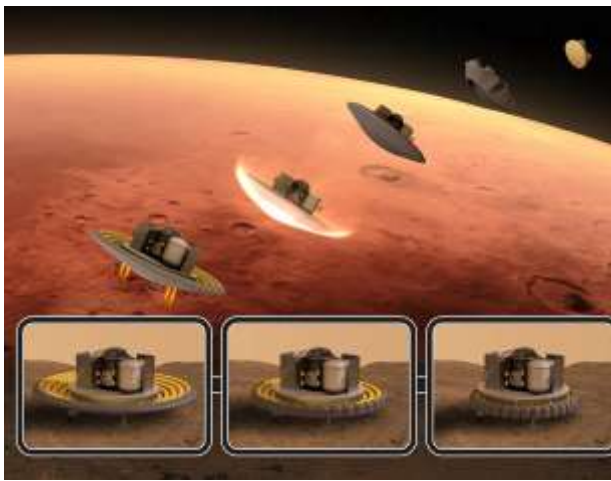

Figure 3. Entry Descent and Landing Configurations

While the HIAD is the reference decelerator for EMC studies; this team evaluated several other technologies for the human Mars mission [4] including the Adaptive Deployable Entry and Placement Technology or ADEPT decelerator [5], the Rigid Mid Lift-to-Drag Ratio aeroshell is another [6] and the heritage capsule design [7].

For the HIAD reference option that is the focus of this paper, payload sits on top of the cylindrical descent module. The lander relies on the Earth to Mars transit system to provide power during the trip to Mars and deploys its own solar arrays to provide power once Mars orbit is achieved. Solid oxide fuel cells provide power as the vehicle flies through the Mars atmosphere and for the first day after landing or until connection to surface power infrastructure is established. Body mounted radiators reject excess vehicle heat, including waste heat from an active cryofluid management system. Each of these systems must be considered when assessing alternate mission operations. The lander design is covered in detail in reference 3.

This paper presents the effects of mission and vehicle design options on lander mass and performance. Section 2 summarizes the Earth launch options include fairing size assumptions, co-manifesting other elements with the lander, and Earth-Moon vicinity operations. Section 3 describes the Mars capture options, specifically aerocapture and propulsive capture are assessed. Finally, the entry, descent, and landing sensitivities are presented in Section 4, including a propellant trade of storable versus an In Situ Resource Utilization production capable oxygen and methane propellant system, engine thrust level, and sensitivity to landed payload mass.

2. EARTH DEPARTURE OPTIONS

Launch Manifest Options

The first step in this journey is getting off of the Earth. The large payload volume and lift capacity offered by the Space Launch System (SLS) is crucial for a human Mars mission. Launch manifest and packaging of the lander depends on the transportation option. Packaging is important because adapter mass and lander primary structure mass are affected by the height of the lander in the fairing when strength, buckling, and stiffness are considered. Reference 8 describes the effect of SLS Launch Vehicle Fairing Size on the payload arrangement and packaging.

The EMC has considered two options for in-space transportation, both have elements that are derived from the Asteroid Robotic Redirect Mission (ARRM) Solar Electric Propulsion (SEP) vehicle. The first, the SEP/Chemical Split option [9], uses a SEP system with power that is limited to what is minimally needed for lander delivery to Mars, 150 kW to the electric propulsion system (the total vehicle power could be 190-280kW depending on mode of operation.) At this power level it would take several years to deliver a lander to Mars. In this option the crew would travel to Mars on a separate much faster system using chemical propulsion (liquid oxygen and methane). The second EMC transportation option, SEP/Chem Hybrid [10] explores what would be required to enable reusability of transportation systems. A reusable system would require double the power level or 300 kW to the electric propulsion system (with total vehicle power of 435 kW), and augmentation by a chemical propulsion system for some maneuvers in planetary gravity wells.

In the SEP/chem split option the lander is integrated with the SEP stage in a 10 m diameter SLS payload fairing (9.1m payload envelope). This allows for the lander to be delivered to Mars using a single SLS launch. The lander and SEP stage are launched together into an elliptical Earth orbit. The SEP stage initiates a spiraling Earth escape trajectory with a lunar gravity assist for the final Earth departure. In the SEP/Chem Hybrid option the reusable hybrid propulsion system (HPS) is launched separate from the landers. Landers are launched to Trans-Lunar injection (TLI) and rendezvous with the hybrid propulsion system in lunar distant retrograde orbit before continuing on to Mars. During Earth escape and

transit to Mars both options assume that the transportation stage will provide power for the lander and its cargo. Figure 4 depicts the lander as it might appear in launch configuration with and without a SEP stage. There is a conical launch vehicle adapter (LVA) with the SEP stage suspended below. Figure 5 shows Earth to Mars transit configuration for the SEP/Chem Split option.

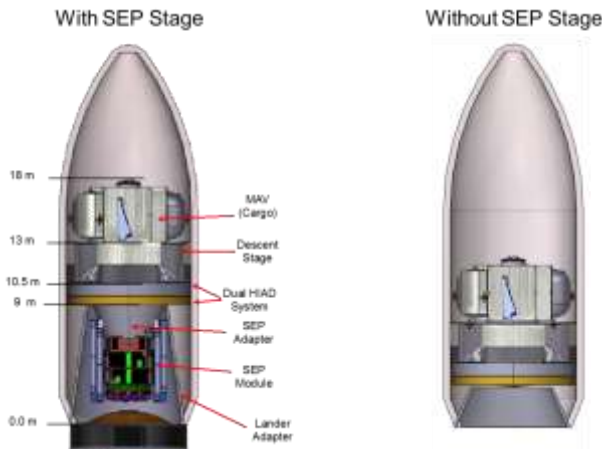

Figure 4. Launch Configuration Options



Figure 5. Earth to Mars Transit Configuration

Launch Fairing Options

Both 8.4 and 10 meter diameter fairing options have been assessed for human Mars missions. The transit habitat and in-space propulsion stages can be packaged within the 8.4 meter option, but packaging the landers within that constraint presents many challenges. Fairing diameter affects design, performance, and operations of the lander, surface cargo, and the design of launch vehicle adapters. These issues are summarized below and described in detail in reference 8.

Current reference architectures assume a 10 meter diameter fairing. Adjusting the lander design to fit within a smaller diameter results in a taller vehicle as propellant tanks grow taller and surface cargo items are stacked or reoriented to the new constraint. In some cases cargo volume limitations prevent packaging of some desired surface manifest elements, thus delaying delivery of mission capabilities and requiring more landers to deliver the same cargo manifest.

Some reoriented payloads have undesirable load paths which will likely result in increased structural mass of those cargo elements.

The taller landers have a higher center of gravity (CG), and tighter packaging of payloads results in reduced flexibility to manage CG with payload positioning. Figure 6 shows an image of the same cargo elements repackaged for the two launch vehicle diameters. This lander, Lander 1 in figure 1, contains a pressurized rover and logistics module and has an x-axis cg location was at 4.6m from the nose (bottom) of the vehicle. When the same payload elements were repackaged to fit in the 8.4m diameter launch vehicle (7.5m dynamic envelope), the stack height increased and the CG location rose to 5.3m from the nose. At Earth launch this taller overall stack height and CG location create challenges for meeting launch stack stiffness requirements and results in more massive adapters. The design changes also drive to a narrower adapter between the Lander and the Mars Ascent Vehicle (MAV), Lander 2 seen in Figures 1 and 2. The narrower adapter has less bending stiffness, lower vibration frequencies and is heavier.

Taller payload stack height and CG location create additional challenges for operations and performance. For a 16m diameter deployed HIAD considered for this case, the CG location in the 8.4 m fairing configuration is approaching the stability limit CG of 5.6m from the nose. Flow impingement during entry and descent is also a concern. For the 10m fairing option the flight profile can be managed to avoid any direct flow impingement on the cargo, but as the stack gets taller flow impingement is likely resulting in an increased burden of thermal protection systems for the cargo which may complicate cargo offloading on the Martian surface. Placement of engines and landing gear is also affected by the reduced diameter. With a taller CG and a smaller diameter base, the landing gear would have to be larger and deploy further to provide the same stability. Tighter packaging could pose challenges for offloading and may affect payload thermal management during transit, and limited deck space could restrict deployment of systems and operation of deck-mounted offloading devices.

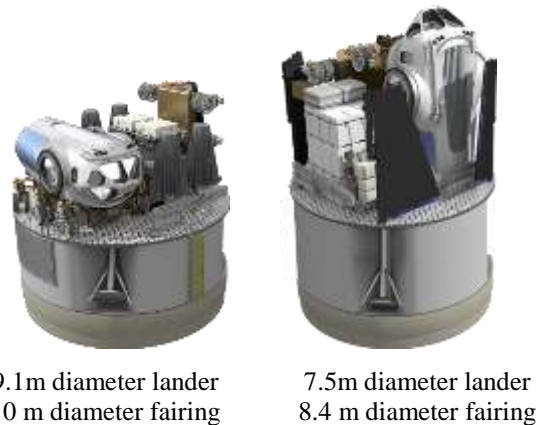

Figure 6. Lander and Cargo Configurations Two Launch Vehicle Fairing Options

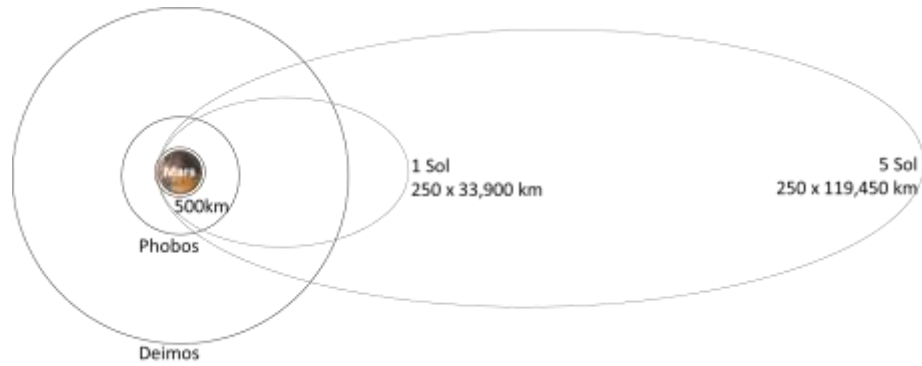

Figure 7. Mars Orbit Options

3. MARS ARRIVAL OPTIONS

Mars arrival presents another opportunity to balance responsibility between the lander and in-space transportation stages. All past Mars landing missions performed direct entry and did not loiter in a parking orbit before descent. In the EMC architecture options, the crew does not travel to Mars in the entry vehicle. It is sent to Mars prior to the crew arrival and must remain in a parking orbit until they arrive. Orbit capture of the entry vehicle could be achieved propulsively using SEP or chemical stages, or using aerodynamic drag in the Mars atmosphere to accomplish aerocapture.

For the SEP/Chem hybrid transportation option Hybrid Propulsion System (HPS) propulsively captures into Mars orbit and spirals down to a 5 Sol orbit before releasing the lander. Five Sol, or five Martian days, refers to the orbital period of the highly elliptical orbit. The dimensions of the parking orbit relative to Phobos and Deimos at Mars are shown in Figure 7. The HPS can continue to provide services (power) to the lander for some portion of the orbit loiter, but at some point will detach from the lander and return to Earth for refueling and reuse. This orbit is higher than has been considered in past human Mars studies but is necessary to minimize flight time and allow for reuse of the HPS. The lander deploys its own solar arrays to provide power after separation from the HPS, see Figure 8. The lander orbits Mars for up to a year waiting for crew arrival. Once crew is on board and prepared for landing, a periapsis lowering maneuver is performed at apoapsis and the two and half-day journey to the surface begins. Solar arrays are jettisoned prior to atmospheric entry with fuel cells providing power for the remainder of descent and landing.

For the SEP/Chem split option SEP power and mission timeline can be minimized if the lander performs aerocapture into Mars orbit. Aerocapture into a one Sol Mars orbit is assumed. The size of the one sol orbit relative to the five-sol orbit is also shown in Figure 7. In this option the SEP stage targets the lander for a 40 km minimum Mars altitude pass, with an arrival velocity of 6.2 km/s, and then separates from

the lander approximately two days prior to Mars atmospheric interface. After separation and through aerocapture the lander would generate its own power using solid oxide fuel cells, only deploying its own solar arrays after the parking orbit was achieved. The HIAD would be deployed some designated time prior to atmospheric interface. The deceleration through the atmosphere would last approximately 7 minutes and result in an orbit with an apoapse of approximately 33,900 km. At apoapse the lander would fire the reaction control system (RCS) propulsion to impart a change in velocity of 15 m/s to raise periapsis to a safe distance above the Martian atmosphere, approximately 250 km altitude above the mean areoid. Just as in the Hybrid option the vehicle may loiter in Mars orbit for up to one year before crew arrival and initiation of descent. Not all landers would loiter that long. Cargo landers could initiate descent soon after orbit arrival but one lander must await the crew.



Figure 8. Mars Orbit Loiter Configuration

While the lander is designed to decelerate using the Martian atmosphere, there are particular concerns with the HIAD decelerator that must be addressed to accommodate aerocapture. The HIAD design uses an inflatable structure covered by a flexible TPS. The inflatable structure is a stacked-torus design, meaning that it is built as a conical stack of pressurized rings, connected to each other and anchored to the central rigid nose by radial structural webbing. While

HIAD flexible TPS samples have survived multiple heat pulse testing, the performance of the material deflated after aerocapture and reinflated up to a year later has not been characterized, and it is infeasible to carry gas generators onboard to keep the HIAD inflated during an extended loiter in Mars orbit between aerocapture and entry. Therefore, the decision was made to carry two separate HIAD's, one for aerocapture and one for entry. The aerocapture HIAD is jettisoned before the orbit periapsis raise burn that occurs after the initial atmospheric pass. To maintain similar ballistic coefficients in current trajectory simulations, the aerocapture HIAD is slightly larger, 18.8 m, compared to the entry HIAD, which has a 16.7 m diameter.

4. ENTRY DESCENT AND LANDING OPTIONS

Entry system trades are covered in other papers. [4, 5, 6, 7] This section focuses on propulsion and cargo capacity trades.

Overview of Entry Descent and Landing Phases

Descent is initiated from apoapsis of the parking orbit using an RCS burn. The entry HIAD is inflated and entry begins at approximately 125 km altitude. The vehicle flies with a maximum hypersonic continuum lift-to-drag ratio of 0.2 and an angle of attack of -16 deg. The guided entry uses a direct force numerical predictor corrector guidance algorithm to control the vehicle until engine ignition. The entry trajectory is designed to maintain maximum deceleration limits below 4 g's for deconditioned crew according to NASA's Human System Integration Requirements. Crew and cargo missions are designed using the same EDL sequence so that pre-deployment of surface cargo demonstrates the sequence prior to crew arrival. The guidance is targeting the time and location to turn on the engines such that the vehicle can land at an altitude of 0 km above the Mars Orbiter Laser Altimeter areoid. The descent sequence initiates when plugs or doors in the rigid nose heatshield covering the eight 100 kN engines are blown off or opened prior to engine ignition. Additional openings are revealed when the vehicle velocity becomes subsonic to deploy the landing legs. The vehicle retains the HIAD to landing to minimize the risk associated with separation. At 12 to 20 m above the surface the engine thrust is reduced such that the vehicle maintains a constant 2.5 m/s descent velocity until touching down on the surface.

Figure 3 illustrated the concept of operations for the reference EDL sequence. Once touchdown is achieved the inflatable portion of the HIAD is deflated and retracted to allow for cargo deployment. As the vehicle nears the surface, the engine plumes will disturb regolith, which has the potential to damage the vehicle and other assets nearby. Retaining the HIAD to the surface offers some protection of the payload from surface plume interactions. To protect other surface assets, landings must occur outside of a predefined keep out zone, currently assumed to be 1 km from any surface asset. Advances in landing accuracy will help to minimize the actual separation distance between landings to no greater than the defined keep out zone. Landing within 50 meters of the landing target is the capability assumed for this mission.

Propulsion System Options

Cryogenic and storable propulsion options have been evaluated for the lander. To minimize cost across the architecture a common engine design for ascent, descent and other applications within the architecture is assumed wherever possible. While recent advancements in manufacturing of rocket engines hold the promise of significantly reducing engine development cost, commonality is still expected to provide savings over multiple unique engine developments. Engine thrust level trades for descent have been performed and a vehicle thrust-to-weight ratio of 2 is desired at engine initiation. The individual engine thrust level is determined by the MAV application. Current lander designs use eight engines at 100 kN (22.5 klbf) of thrust each to provide the necessary thrust for descent and landing. Using multiple engines for descent distributes the plume over a wide area and is expected to minimize site alteration that could threaten landing stability.

Liquid oxygen and methane propulsion is assumed for 2 of 3 architecture options studied in 2016, and that choice is driven by the Mars ascent vehicle. In situ production of liquid oxygen for ascent reduces required lander cargo capacity because the Mars ascent vehicle can be delivered with fuel only and then filled with liquid oxygen on the Martian surface well before the crew arrive. Methane is chosen as the fuel for several reasons. Propellant combinations with higher mixture ratios are favored to allow the greatest benefit of surface oxygen production. The methane storage temperature is close to the liquid oxygen storage temperature and this simplifies the cryofluid management system design. Ascent performance is highly sensitive to Isp, and as the heaviest payload, MAV mass impacts lander and transportation stage design. Packaging of both propellant and engines is another consideration. Other hydrocarbons have been studied, but none are significantly better than methane, and a methane design allows for future extensibility to methane production on the Martian surface.

For the third architecture option a storable propellant combination of monomethylhydrazine (MMH) and nitrogen tetroxide (NTO) is assumed for lander and MAV. Because the MAV cannot rely on in-situ propellant production in this case it must be delivered fully loaded with propellant. A MAV capable of ascending to a 1 Sol or 5 Sol orbit with storable propellants would be on the order of 40-50t and would result in significantly larger landers to deliver them. To keep the lander size relatively small, it was decided that this architecture should assume a MAV that only ascended to a low Mars orbit, 500 km circular, with an orbital taxi or other element completing the remainder of ascent with the crew. Even after reducing the MAV performance requirements, the storable MAV is still in excess of the 20mt payload capacity assumed for the cryogenic oxygen and methane options. A lander payload capability of at least 24t is needed for the storable architecture option.

Sensitivity to payload mass

Setting the lander payload capacity affects the number of landers required to complete a mission which affects the number of launches from Earth and the number and size of transportation stages to deliver those landers to Mars. With 20t payload delivery capability on each lander, a total of 4 landers would be required to support a long duration surface mission. If each lander could carry 27t of payload to the surface then that number could be reduced to three [2]. A lander capable of delivering 40t of payload was assumed in NASA’s Design Reference Architecture 5.0. With this level of payload capability it may be possible to complete a mission using only two landers. The challenge, however, of payload capabilities in excess of 30t is in the packaging. Habitats and other human mission support infrastructure is on average much lower density than past robotic Mars mission payloads. When large elements have to be stacked on top of each other flow impingement during entry becomes a concern as well as the increased complexity of cargo offloading (most of which must be done remotely before the crew arrive. Other issues with tall lander and payload stacks and high CGs discussed in section 2 would be exacerbated as additional payload is added to each stack. For this reason and because of the reduce demand on transportation stages only 20 - 27t payload delivery capability options were assessed in EMC architectures.

5. RESULTS

Mass summaries of the lander options assessed are given in Table 1. Options for each transportation architecture are included. The SEP/Chem Split architecture options, which use aerocapture, have heavier decelerator system masses due to the decision to carry two separate HIAD systems for aerocapture and entry descent and landing. The SEP/Chem

Split lander options are too heavy to be launched to trans lunar injection (TLI) based on assumed performance of 45-50t for the SLS Block 2. The reusable SEP/Chem Hybrid architecture option requires elements be launched to TLI to meet up with the hybrid propulsion system, however only the 20t payload LOX/Methane option may be feasible assuming 50t for SLS TLI performance, which must include launch adapters.

Both 20 and 27t payload capability options were assessed for LOX/Methane landers. MMH/NTO landers have a payload capacity that is consistent with the storable MAV requirements for that option. Payload mass fractions for each transportation architecture option are similar across LOX/Methane and MMH/NTO landers, 0.37-0.42 for SEP/Chem Split and 0.43-0.47 for the SEP/Chem Hybrid options. Lander performance is relatively insensitive to descent propulsion Isp. To expedite analysis the decelerator diameters were fixed and the ballistic coefficient was allowed to vary between the payload options. Further refinements with a fixed ballistic coefficient would result slight variations in decelerator masses. The variation is anticipated to be small because it is only the lightweight inflatable portion of the HIAD that would be affected.

These options were developed by a team of subsystem and discipline experts. This work was then used as the basis for a parametric mass model of this lander. The parametric model allows rapid exploration of the tradespace. Figure 9 shows an example of how this model can be used to evaluate sensitivity of a variety of parameters to payload mass. Additional tradespace and sensitivities studies can be found in Ref. [10].

Table 1. Mass Summary of Lander Options Assessed

Component	Masses (kg)					
	Aerocapture to 1 sol Parking Orbit SEP/Chem Split Options			Propulsive delivery to 5 sol Parking Orbit SEP/Chem Hybrid Options		
	27 t LOX/Methane	20 t LOX/Methane	NTO/MMH	27 t LOX/Methane	20 t LOX/Methane	NTO/MMH
Structures	5442	4961	4961	4652	4253	4136
Propulsion	5310	4899	5206	5260	4842	5189
Power	1437	1217	1575	1437	1437	1575
C&DH	136	136	136	136	136	136
C&T	76	76	76	76	76	76
GNC	116	116	116	116	116	116
Thermal	357	328	573	357	328	573
Decelerator	9444	9444	9444	4185	4185	4185
Dry Mass	22,318	21,177	22,087	16,219	15,373	15,986
Cargo	27,000	20,000	23,881	27,000	20,000	24,187
Non-prop Fluids	851	848	951	850	843	920
Inert Mass	50,168	42,025	46,919	44,068	36,216	41,093
Used Propellant	14,093	11,668	12,289	12,519	10,367	11,497
Total Wet Mass	64,261	53,693	59,208	56,587	46,583	52,590

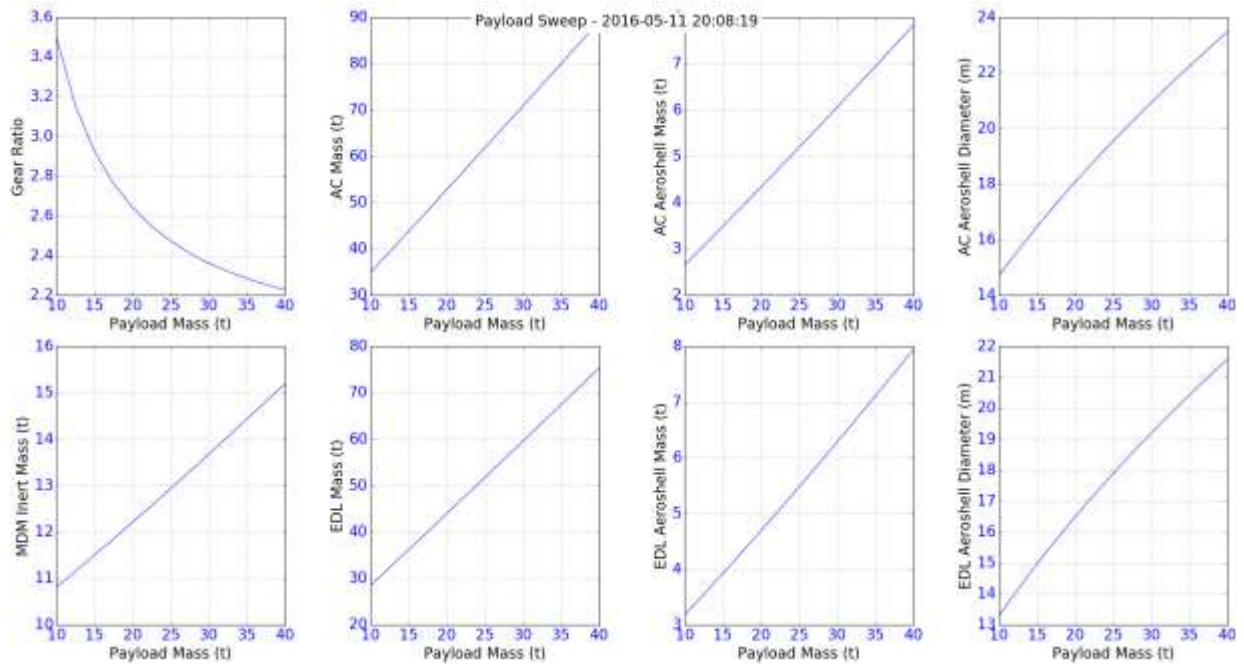

Figure 9. Sensitivity to Payload Mass

6. CONCLUSIONS

Lander design and performance is tied to every other element of the mission architecture. Launch vehicle fairing options affect lander height and center of gravity as well as its flight profile through entry and descent and even its design for landing stability. Performance requirements for transportation stages that carry crew and cargo to Mars and back are driven by their largest payload, the lander. The balance of responsibility between those stages and the lander during transit determines the number of decelerators the lander carries and its parking orbit at Mars. The deployment and design of surface payloads depend on how they are packaged on each lander, and while lander performance is relatively insensitive to the propellant choice options assessed, that choice significantly the capability of the MAV and the payload capacity of the lander, assuming common engine developments for both vehicles.

One thing that is clear from these cases is that it is unlikely that any lander options will be launched directly to TLI. Only one of the options studied may be light enough, however while mass growth allowance has been applied to all cases there are still areas of the design that are immature making future mass growth in excess of the allowance possible. In addition, these cases represent only the HIAD decelerator options which is the lightest entry system technology considered for human landing missions. Alternate decelerator options ADEPT, Mid L/D, and Capsule are all heavier [4]. The inability to deliver landers to TLI means that the reusable SEP/Chem Hybrid architecture must be adjusted

in the future to include additional propulsion capabilities or other creative solutions to this problem.

This paper presents the impacts on Mars lander design due to several transportation and operational decisions, but the only way to identify the most optimal solution is to look at the entire end to end mission architecture as a whole. Some minor penalty in lander mass may be acceptable if it eliminates risk in another area or improves the value of the mission.

REFERENCES

- [1] Craig, Douglas A., Troutman, Patrick, Herrmann, Nicole, "Pioneering Space Through and Evolvable Mars Campaign," *AIAA SPACE 2015*, Pasadena, CA, August 31-September 2, 2015
- [2] Toups, L., Brown K., and Hoffman, S. J., "Transportation-Driven Mars Surface Operations Supporting an Evolvable Mars Campaign," *IEEE Aerospace Conference 2015*
- [3] Polsgrove, Tara P., Cianciolo, A., et al, "Human Mars Lander Design for NASA's Evolvable Mars Campaign," *IEEE Aerospace Conference*, Big Sky, MT, March 5-12, 2016.
- [4] Cianciolo, Alicia, Polsgrove, Tara P., "Human Mars Entry, Descent, and Landing Architecture Study Overview," *AIAA SPACE 2016*, Long Beach, CA, September 13-16, 2016
- [5] Cassell, A., Brivkalns, C., Garcia, J., Bowles, J., Kinney, D., Yount, B., McGuire, K., Wercinski, P., Cianciolo, A., Polsgrove, T. "Human Mars Mission Design Study Utilizing the Adaptive Deployable Entry and Placement Technology," *IEEE Aerospace Conference*, Big Sky, MT 2017.
- [6] Cerimele, C., Robertson, E., Sostaric, R., Campbell, C., Robinson, P., Hershey, M., Stachowiak, S., Matz, D., Braden, E., Johnson, B., Garcia, J., Bowles, J., Kinney, D. "A Rigid Mid Lift-to-Drag Ratio Approach to Human Mars Entry, Descent, and Landing" *AIAA SciTech 2017*, Grapevine TX.
- [7] Price, H., Manning, R., Sklyanskity, E., Braun, R., "A High-Heritage Blunt-Body Entry, Descent, and Landing Concept for Human Mars Exploration," *AIAA-2016-0219*
- [8] Jefferies, Sharon, Collins, Tim, Cianciolo, Alicia D., Polsgrove, Tara, "Impacts of Launch Vehicle Fairing Size on Human Exploration Architectures" *IEEE Aerospace Conference*, Big Sky, MT 2017.
- [9] Percy, T., McGuire, M., Polsgrove, T., "In-space Transportation for NASA's Evolvable Mars Campaign," *AIAA SPACE 2015*, Pasadena, CA, August 31-September 2, 2015
- [10] Merrill, R., Chai, P., Qu, M., "An Integrated Hybrid Transportation Architecture for Human Mars Expeditions," *AIAA SPACE 2015*, Pasadena, CA, August 31-September 2, 2015
- [11] Samareh, J., et al. "Rapid Systems Analysis and Trade Studies for Human Mars EDL" NASA-TM (in preparation).

BIOGRAPHY



Tara Polsgrove is an aerospace engineer in the Flight Programs and Partnerships Office at NASA's Marshall Space Flight Center. She has been with NASA since 2000 and has worked on many conceptual designs of advanced spacecraft, including performance and vehicle integration for the Altair Lunar Lander. Her background is in interplanetary trajectory optimization and mission analysis. Recent work has focused on Mars transportation and lander designs supporting missions to send humans to Mars. Ms. Polsgrove has a Bachelor of Science in Aerospace Engineering from the Georgia Institute of Technology and a Master of Science in Engineering with a Systems Engineering focus from the University of Alabama in Huntsville.



Alicia Dwyer Cianciolo is an aerospace engineer at the NASA Langley Research Center. She specializes in developing simulations to analyze vehicle flight through different atmospheres in the solar system. Primarily focusing on Mars over the past 15 years, she has worked on several missions to the planet including the *Odyssey* and *Reconnaissance Orbiter* aerobraking operations, the *Exploration Rovers*, and as a member of the Entry, Decent and Landing Team that successfully landed the *Curiosity Rover* on Mars in August of 2012. She is currently supporting NASA's the next lander mission to Mars, *InSight*, and is working to analyze entry technologies that will enable human exploration of the planet. She holds a Bachelor of Science degree in Physics from Creighton University and a Master of Science degree in Mechanical Engineering from The George Washington University.



Herbert Thomas is an aerospace engineer in the Advanced Concepts Office at NASA's Marshall Space Flight Center. His background is in orbital mechanics, mission analysis, advanced space propulsion, and propulsion system mass estimation. He has been with NASA since 2004 and, before that, worked as a software engineer in industry. He has worked on many conceptual vehicle designs as both an analyst and study lead. Dr. Thomas has a Bachelor of Science in Aerospace Engineering, Master of Science in Engineering, and a Doctor of Philosophy in Mechanical Engineering from the University of Tennessee.



Jamshid Samareh is a senior research aerospace engineer in the Vehicle Analysis Branch of NASA Langley Research Center. His research interests are in Entry, Descent, and Landing (EDL), mass modeling, multidisciplinary analysis and design optimization (MDAO),

fluid-structure interaction, geometry modeling, and shape optimization.



Tim Collins is a senior structures research engineer in the Structural Mechanics and Concepts Branch at NASA Langley Research Center in Hampton, Virginia. His area of expertise is spacecraft structural design and analysis with an emphasis on conceptual-design trade studies supported by

hardware-prototype demonstrations. He has been with NASA since 1987, working on structural concepts for numerous NASA programs ranging from precision telescopes to Lunar and Mars landers. He also specializes in structurally efficient concepts for robotic operations, including those required for in-space or surface-based servicing and assembly. Mr. Collins has a Bachelor's Degree in Physics from the University of Rochester and a Master of Science Degree in Mechanical and Aerospace Engineering from the University of Virginia.