

# Molecular coevolution of neuropeptides gonadotropin-releasing hormone and kisspeptin with their cognate G protein-coupled receptors

Dong-Kyu Kim<sup>1</sup>, Eun Bee Cho<sup>1</sup>, Mi Jin Moon<sup>1</sup>, Sumi Park<sup>1</sup>, Jong-Ik Hwang<sup>1</sup>, Jean-Luc Do Rego<sup>2</sup>, Hubert Vaudry<sup>2</sup> and Jae Young Seong<sup>1\*</sup>

<sup>1</sup> Graduate School of Medicine, Korea University, Seoul, South Korea

<sup>2</sup> Laboratory of Neuronal and Neuroendocrine Differentiation and Communication, INSERM U982, University of Rouen, Mont-Saint-Aignan, France

## Edited by:

Billy K. C. Chow, University of Hong Kong, China

## Reviewed by:

Jack Falcon, Université Pierre et Marie Curie, France

Leo T. O. Lee, The University of Hong Kong, Hong Kong

## \*Correspondence:

Jae Young Seong, Graduate School of Medicine, Korea University, Seoul 136-705, South Korea.

e-mail: [jyseong@korea.ac.kr](mailto:jyseong@korea.ac.kr)

The neuropeptides gonadotropin-releasing hormone (GnRH) and kisspeptin (KiSS), and their receptors gonadotropin-releasing hormone receptor (GnRHR) and kisspeptin receptor (KiSSR) play key roles in vertebrate reproduction. Multiple paralogous isoforms of these genes have been identified in various vertebrate species. Two rounds of genome duplication in early vertebrates likely contributed to the generation of these paralogous genes. Genome synteny and phylogenetic analyses in a variety of vertebrate species have provided insights into the evolutionary origin of and relationship between paralogous genes. The paralogous forms of these neuropeptides and their receptors have coevolved to retain high selectivity of the ligand–receptor interaction. These paralogous forms have become subfunctionalized, neofunctionalized, or dysfunctionalized during evolution. This article reviews the evolutionary mechanism of GnRH/GnRHR and KiSS/KiSSR, and the fate of the duplicated paralogs in vertebrates.

**Keywords:** kisspeptin, gonadotropin-releasing hormone, G protein-coupled receptors, comparative genomics, evolution

## INTRODUCTION

Neuropeptides serve as messenger molecules to regulate a variety of physiological functions in the nervous and neuroendocrine systems of vertebrates (Hoyle, 1999). In humans, more than 70 genes have been identified to encode approximately 100 short mature peptides that function either at the brain or periphery. Most neuropeptide genes can be categorized into small families consisting of one to four members that originate from a common ancestral gene. These families have diversified through evolutionary mechanisms, like gene/chromosome duplication, followed by gene modification and gene loss (Conlon and Larhammar, 2005; Lee et al., 2009; Kim et al., 2011). Receptors for neuropeptides are generally G protein-coupled receptors (GPCRs) which transmit signals from the cell membrane to the intracellular space through activation of heterotrimeric G proteins (Oh et al., 2006). Similar to neuropeptide ligands, receptors have also diverged evolutionarily to maintain high selectivity for their cognate ligands (Fredriksson et al., 2003; Acharjee et al., 2004; Li et al., 2005; Cho et al., 2007).

Gonadotropin-releasing hormone-1 (GnRH1, also known as mammalian GnRH) and its mammalian type-I receptor (GnRHRm1) are an essential neuropeptide/receptor pair for sexual development and reproductive function in vertebrates (Schally et al., 1971; Millar et al., 2004). GnRH1 is synthesized in the

hypothalamus and released into the hypophyseal portal circulation in a pulsatile manner. In the pituitary, binding of GnRH1 to GnRHRm1 regulates secretion of the gonadotropins, luteinizing hormone, and follicle-stimulating hormone. The secreted gonadotropins then stimulate gametogenesis and steroidogenesis in the gonad. Steroid hormones secreted from the gonad exert either negative or positive feedback action on the hypothalamus and pituitary to control GnRH1 and gonadotropin secretion, hence establishing the hypothalamic-pituitary–gonadal (HPG) axis to control the reproductive function in mammals (Hrabovszky et al., 2007; Ohkura et al., 2009). In addition, identification and characterization of kisspeptin, a product of the *KiSS1* gene and its receptor gene *KiSS1R* (or GPR54) indicates that the pair plays a key role in initiating puberty as well as steroid hormone feedback (de Roux et al., 2003; Seminara et al., 2003; d'Anglemont de Tassigny et al., 2007). In mammals, kisspeptin binding to KiSS1R induces GnRH1 secretion from GnRH1 neurons (Messenger et al., 2005). Neurons expressing KiSS1 in the anteroventral periventricular nucleus (APVN) and arcuate nucleus (ARC) are the main targets for estrogens to exert either positive or negative feedback on GnRH1 secretion (Oakley et al., 2009; Ohkura et al., 2009). Thus, the KiSS1/KiSS1R pair functions as a molecular gatekeeper of the HPG axis for sexual maturation and reproductive function in mammals.

To date, multiple isoforms of *KiSS1* and *GnRH1* have been identified in a variety of vertebrates (Um et al., 2010; Kim et al., 2011). For instance, three *KiSS* isoforms (*KiSS1*, *KiSS1b*, and *KiSS2*) have been identified in *Xenopus tropicalis*, and three

**Abbreviations:** APVN, anteroventral periventricular nucleus; ARC, arcuate nucleus; ECL, extracellular loop; GnRH, gonadotropin-releasing hormone; GnRHR, gonadotropin-releasing hormone receptor; GPCR, G protein-coupled receptor; HPG, hypothalamic-pituitary–gonadal; KiSS, kisspeptin; KiSSR, kisspeptin receptor.

gonadotropin-releasing hormone (*GnRH*) isoforms (*GnRH1*, *GnRH2*, and *GnRH3*) exist in many fish species. Multiple isoforms for the respective receptors, kisspeptin receptor (*KiSSR*) and gonadotropin-releasing hormone receptor (*GnRHR*), have also been identified (Lee et al., 2009; Kim et al., 2011). During evolution, the function of paralogs can diversify. Although the *GnRH*/kisspeptin system has been well characterized in rodents, which only have one *KiSS1* and one *GnRH1* ligand–receptor pair, the function of the paralogous genes in other vertebrates remains poorly understood. In addition, some non-mammalian vertebrate species do not have orthologous genes for *KiSS1/KiSS1R* or *GnRH1/GnRHRm1*, suggesting that a paralogous set of the genes may substitute for the function of the absent genes. In avian species, the *KiSS*/*KiSSR* system is completely absent, indicating that *KiSS* signaling is not required in birds. During evolution, the *KiSS*/*KiSSR* and *GnRH*/*GnRHR* genes have been duplicated, generating at least three paralogs whose functions have diverged to some extent. These features make the *KiSS* and *GnRH* systems excellent models to understand molecular evolution of peptide ligand and receptor pairs. This article reviews the evolution of the *GnRH* and *KiSS* ligand–receptor pairs and the fate of their duplicated paralogous genes in vertebrates.

## TWO ROUNDS OF GENOME DUPLICATION PRODUCED MULTIPLE ISOFORMS OF NEUROPEPTIDES AND THEIR RECEPTORS

The fact that neuropeptides and receptors group into small families can be accounted for by two rounds of large-scale genome duplication in an early vertebrate ancestor that resulted in up to four copies of each gene (Ohno, 1970; Larhammar et al., 2002). Further, after the divergence of fish and land vertebrates, a teleost fish-specific third round of genome duplication is believed to have produced eight copies of a gene family (Larsson et al., 2008). Genome duplication events often produce paralogous chromosomal regions, also called paralogs (Lundin, 1993). Analysis of gene arrangement within paralogs allows the relationships among and origins of each gene family to be traced (Um et al., 2010).

### DUPLICATIONS OF THE *KiSS*- AND *KiSSR*-CONTAINING GENOMES

As *X. tropicalis* has three forms of *KiSS* genes, it is presumable that the multiple genes were generated by at least two rounds of genome duplication during early vertebrate evolution (Lee et al., 2009; Um et al., 2010). Genome synteny analysis comparing vertebrate *KiSS*-containing genome fragments with human chromosomes allowed identification of four genome fragments that share several paralogous genes. These include *TEAD1/2/4*, *K/N/R/HRAS*, *KCNJ7/8/9/11*, *CACNA1A/C/S*, *SOX5/6/13*, *PLEKHA4/5/6/7*, and *PIK3C2A/B/G* (Figure 1). This observation suggests that these paralogous genes are likely members of four early paralogs, containing *KiSS1*, *KiSS2*, *KiSS1b*, or the fourth form of *KiSS*. During millions of years of evolution, many paralogous genes have been rearranged within paralogs, translocated to other chromosomes, or lost (Figure 1). The absence of the fourth *KiSS* gene, despite the presence of the fourth paralogon in vertebrates, suggests that the fourth *KiSS* gene was lost before or just after the divergence of teleosts and tetrapods. The presence of the *KiSS1b* gene only in *X. tropicalis* indicates that the *KiSS1b* gene

has been dysfunctionalized in a wide variety of vertebrates. No teleost-specific *KiSS* duplication has been observed in fish species.

Comparison of *KiSSR*-containing genomes in *X. tropicalis* with other vertebrate species also supports tetraploidization of *KiSSR*-containing paralogs sharing paralogous genes including *NOTCH1/2/3/4*, *PTPRD/K/S/U*, *STXBPI/2/3*, *ARID1A/1B/3A/3C*, *PALM1/2/D*, *PTBP1/2/ROD1*, and *ABCA1/4/7* (unpublished data). The teleost-specific duplication of a *KiSSR*-containing genome has not been identified. Similar to the *KiSS* gene, the fourth *KiSSR* gene is absent in all vertebrates and *KiSS1bR* is present in only *X. tropicalis*.

As a result of these genome duplications, vertebrates have various numbers of *KiSS*/*KiSSR* pairs in a single species (Figure 2). In the fish species, zebrafish and medaka contain two *KiSS1/KiSS1R* and *KiSS2/KiSS2R* pairs, whereas torafugu, green puffer fish, and stickleback have only one *KiSS2/KiSS2R* pair. In the tetrapod lineage, *X. tropicalis* preserves all currently identified paralogous isoforms of the *KiSS*/*KiSSR* pair and thus has three *KiSSs* (*KiSS1*, *KiSS1b*, and *KiSS2*) and three *KiSSRs* (*KiSS1R*, *KiSS1bR*, and *KiSS2R*). On the other hand, the anole lizard has only the *KiSS2/KiSS2R* pair. Interestingly, in the avian phylum, the chicken and zebra finch do not possess any form of *KiSS* and *KiSSR*. Although most mammals, including humans and rodents, contain only *KiSS1* and *KiSS1R*, the platypus, a monotreme species, has *KiSS1/KiSS1R* and *KiSS2/KiSS2R*. In all species examined for this article, the *KiSS* isoform and cognate receptor isoform coexisted (Figure 2).

### DUPLICATIONS OF *GnRH*- AND *GnRHR*-CONTAINING GENOMES

Tetraploidization of *GnRH*- and *GnRHR*-containing genomes was recently demonstrated (Kim et al., 2011). Synteny studies of *GnRH*-containing genomes in tetrapods revealed the presence of four paralogs that contain *EBF1/2/3/4*, *PPP2R2B/D*, *ADAM12/19*, *DOCK1/2/5*, *FAM196A/B*, *NKX2-3/5/6*, *STC1/2*, *CPXM1/2*, and *PTPRA/E*. These studies revealed that the fourth *GnRH* gene likely disappeared before the divergence of teleosts and tetrapods, and that *GnRH3* was lost in the tetrapod lineage after the divergence of teleosts and tetrapods (Kim et al., 2011).

Evolution of the *GnRHR* gene is more complicated than that of *GnRH* due to teleost-specific duplications of *GnRHR*-containing genomes and the inability to resolve the origin of mammalian type-I *GnRHR* (*GnRHRm1*). Genome synteny and phylogenetic analyses suggest the presence of four *GnRHR* paralogs: non-mammalian type-I (*GnRHRn1*), non-mammalian type-II (*GnRHRn2*), non-mammalian type-III/mammalian type-II (*GnRHRn3/m2*), and mammalian type-I (*GnRHRm1*; Kim et al., 2011). *GnRHRn1* and *GnRHRn2* were likely generated by a local duplication before the divergence of tetrapods and fish. *GnRHRm1* was only identified in mammals and its evolutionary origin and relationship with other *GnRHR* types is unclear due to a lack of synteny between mammalian genomes containing *GnRHRm1* and genomes of any non-mammalian species. In fish, a third round of genome duplication produced a copy of *GnRHRn1* and *GnRHRn3* (*GnRHRn1b* and *GnRHRn3b*, respectively; Kim et al., 2011).

In the five fish species for which genome information is available in ENSEMBL, two or three *GnRH* isoforms have been

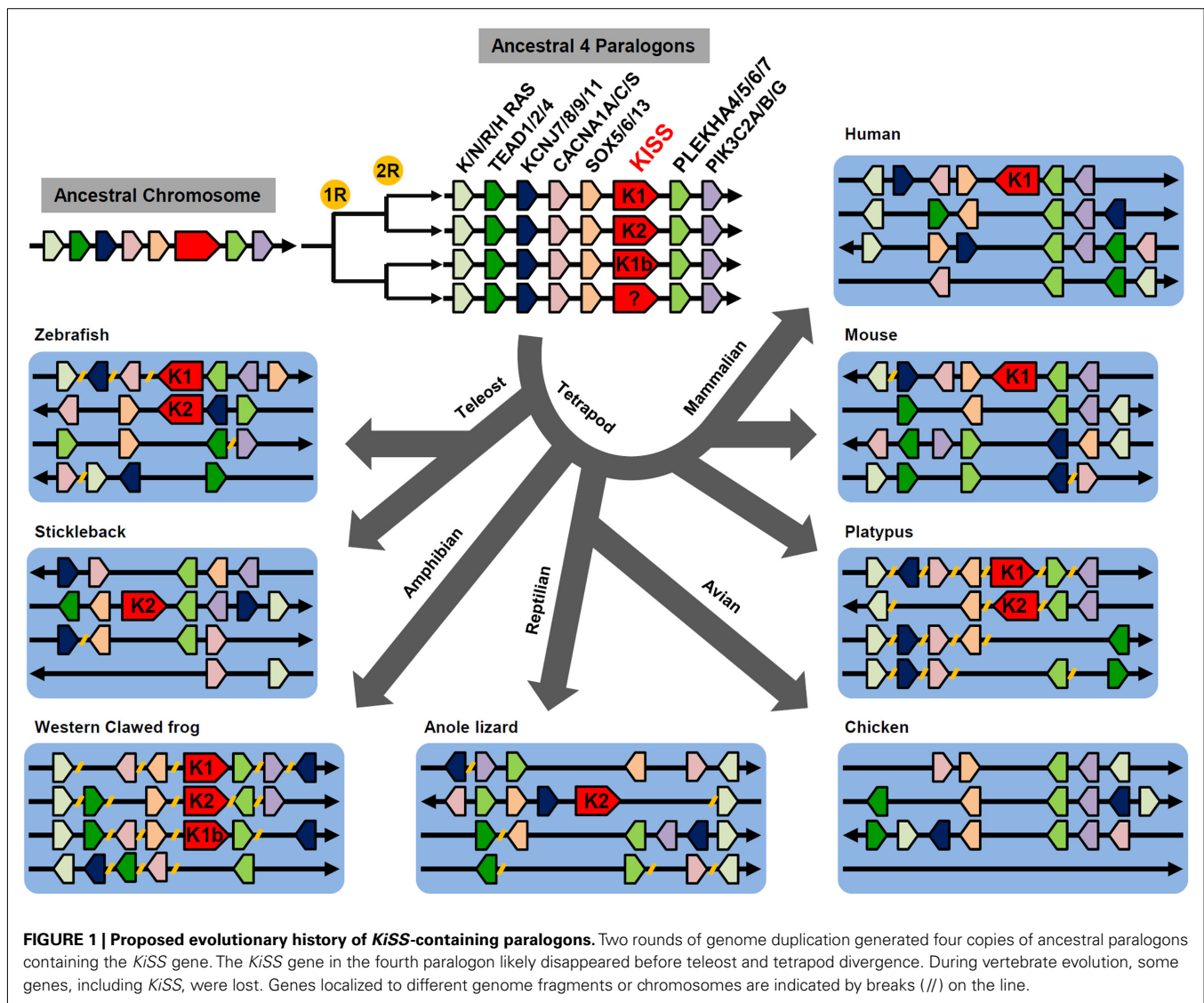

identified. Zebrafish has two *GnRH* genes (*GnRH2* and *GnRH3*), whereas other fish, medaka, stickleback, green puffer fish, and torafugu have all three forms of *GnRH* (*GnRH1*, *GnRH2*, and *GnRH3*; **Figure 2**). The literature indicates that salmon species lack *GnRH1*, while catfish and eel lack *GnRH3* (Kah et al., 2007; Okubo and Nagahama, 2008). In the tetrapod lineage, most species except for rodents have two forms of *GnRH* (*GnRH1* and *GnRH2*). Due to insufficient genetic information investigators were unable to identify the *GnRH2* gene in the anole lizard, but believe the gene exists in this species because other reptilian species such as the gecko has two forms of the *GnRH* gene (Ikemoto and Park, 2003, 2007). Fish have four or five *GnRHRs* and one or two of them are generated by teleost-specific genome duplication (Kim et al., 2011). Thus, in addition to *GnRHRn1*, *GnRHRn2*, and *GnRHRn3*, torafugu, green puffer fish, and stickleback have two additional isoforms (*GnRHRn1b* and *GnRHRn3b*) and medaka and zebrafish each possess one additional isoform (*GnRHRn1b* and *GnRHRn3b*, respectively). Amphibians and reptiles likely have three forms of *GnRHR* (*GnRHRn1*, *GnRHRn2*, and *GnRHRn3*) and avians have

two forms of *GnRHR* (*GnRHRn1* and *GnRHRn2*). In mammals, platypus and monkeys have two *GnRHR* forms (*GnRHRm1* and *GnRHRm2*), whereas rodents and humans have only one form (*GnRHRm1*; **Figure 2**).

### MOLECULAR COEVOLUTION OF NEUROPEPTIDES AND COGNATE RECEPTORS TO MAINTAIN HIGH AFFINITY LIGAND-RECEPTOR INTERACTION

Although the amino acid sequences of vertebrate neuropeptides and the cognate receptors have diverged from an ancestral system during evolution, core conserved sequences have been retained, allowing for the maintenance of a core structure that is required for ligand-receptor interaction and receptor conformation (Fredriksson et al., 2003; Acharjee et al., 2004; Li et al., 2005; Cho et al., 2007). For instance, sequence alignment of peptides across vertebrate species revealed that core sequences responsible for high affinity binding to the cognate receptor have largely been conserved throughout evolution (Cho et al., 2007). Domains critical for ligand interaction and conformation of the receptor are also

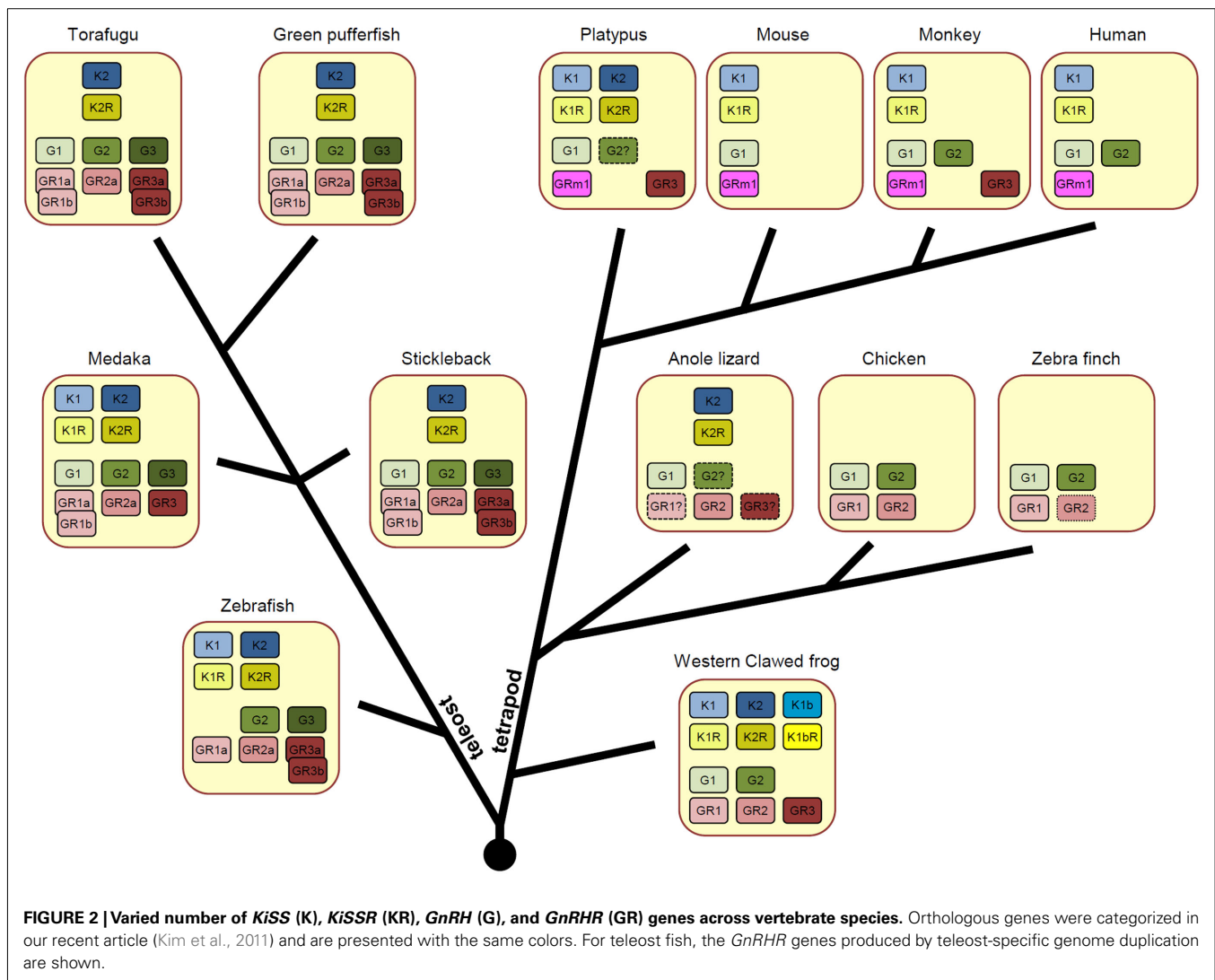

well conserved across vertebrate species, indicating high evolutionary selective pressure to maintain high affinity binding to cognate ligands (Wang et al., 2001; Acharjee et al., 2004; Li et al., 2005). Sequence divergence within neuropeptide and receptor families may explain how each paralogous isoform achieved distinct ligand–receptor selectivity. Amino acid changes in a neuropeptide isoform are usually accompanied by a change in the corresponding motif(s) of the cognate receptor (Acharjee et al., 2004; Cho et al., 2007; Moon et al., 2012).

#### LIGAND–RECEPTOR SELECTIVITY IN THE *KiSS*–*KiSSR* SYSTEM

The *KiSS1* peptide sequences differ between non-mammalian species and rodents and humans. Human *KiSS1* encodes a 145-amino acid precursor that is enzymatically cleaved into 54-, 14-, 13-, or 10-amino acid peptides sharing a common C-terminal sequence with amidation on phenylalanine (Kotani et al., 2001; Muir et al., 2001; Ohtaki et al., 2001). The *KiSS1* peptides in rat and mouse also have a highly conserved C-terminal decapeptide sequence that is amidated on tyrosine. In fact, this C-terminal decapeptide (kisspeptin-10, metastatin 45–54) is the

minimal sequence required for receptor activation (Kotani et al., 2001; Muir et al., 2001; Ohtaki et al., 2001). The *KiSS1* decapeptide sequences from non-mammalian vertebrates vary at position 3 (Leu for fish species, Val for *X. tropicalis* *KiSS1b*, and Trp for other species, including *KiSS1a* from *X. tropicalis* and *KiSS1* from most mammals; Lee et al., 2009). Interestingly, fish *KiSS1* and *X. tropicalis* *KiSS1b* precursors have a conserved dibasic site followed by a conserved Gln five amino acids upstream of the decapeptide, leading to prediction of 15-amino acid peptide with N-terminal pyroglutamylation. These pentadecapeptides are more potent activators of *KiSS1R* than decapeptides in fish and *X. tropicalis* (Lee et al., 2009). Thus, for non-mammalian *KiSS1* genes, pyroglutamylated pentadecapeptides are likely the most potent endogenous forms.

The family of the *KiSS2* decapeptides exhibits conserved Phe-amidation at the C-terminus, but amino acids at positions 1, 3, and 5 differ from the corresponding residues in the *KiSS1* decapeptide. Furthermore, the presence of a conserved basic amino acid three amino acids upstream of the decapeptide suggests that the mature peptide produced from *KiSS2* is 12-amino acid long (Lee

et al., 2009). The KiSS2 dodecapeptide has been detected in the *Xenopus laevis* brain using immunoaffinity purification (Lee et al., 2009). Indeed, the KiSS2 dodecapeptides from zebrafish and *Xenopus* are highly potent activators of KiSS2R expressed in CV-1 cells (Lee et al., 2009). Although some cross-reactivity exists between peptides and receptors, each peptide isoform exhibits relatively high affinity toward its own receptor (Lee et al., 2009), suggesting that KiSS peptides and receptors coevolved to retain high ligand–receptor selectivity. However, the molecular determinants that confer such differential ligand–receptor selectivity remain poorly understood in the KiSS system.

#### LIGAND–RECEPTOR SELECTIVITY IN THE GnRH–GnRHR SYSTEM

The amino acid sequence of GnRH1 ([Tyr<sup>5</sup>, Leu<sup>7</sup>, Arg<sup>8</sup>] GnRH) orthologs varies by one or two amino acids at positions 5 and 8 (Powell et al., 1994; Yoo et al., 2000). The GnRH2 ([His<sup>5</sup>, Trp<sup>7</sup>, Tyr<sup>8</sup>] GnRH) sequence is fully conserved in almost all vertebrates and differs from GnRH1 by amino acids at positions 5, 7, and 8 (Fernald and White, 1999). GnRH3 ([Tyr<sup>5</sup>, Trp<sup>7</sup>, Leu<sup>8</sup>] GnRH) is found only in fish species (Powell et al., 1994). Each form of GnRH exhibits a distinct affinity for different GnRHR forms. For instance, GnRH1 generally has a high affinity toward GnRHRm1 but relatively low affinity for GnRHRm2 and other non-mammalian GnRHRs. In contrast, GnRH2 has low affinity for GnRHRm1 but high affinity for other GnRHR forms.

Molecular determinants conferring such ligand–receptor selectivity have been relatively well defined in the GnRH1 and GnRHRm1 system. For instance, the residues in GnRHRm1 (i.e., Asp<sup>98</sup>, Asn<sup>102</sup>, Lys<sup>121</sup>, Asn<sup>212</sup>, Trp<sup>280</sup>, Trp<sup>289</sup>, and Tyr<sup>290</sup>) that are required for binding to GnRH1 have been identified using mutagenesis and computational modeling (Millar et al., 2004). Interestingly, these residues are similarly conserved in GnRHRn1, n2, and n3/m2 (Millar et al., 2001; Wang et al., 2001). Thus, these residues may not confer differential ligand selectivity toward GnRH1 or GnRH2, but instead are important for the overall ligand–receptor interaction and receptor conformation. In fact, high affinity binding between GnRH1 and GnRHRm1 has been explained by a Ser–Glu/Asp–Pro (SE/DP) motif in extracellular loop 3 (ECL3) of the receptor (Flanagan et al., 1994; Fromme et al., 2001). The positions of Ser and Pro in this motif are known to permit electrostatic interaction with Arg<sup>8</sup> of GnRH1 and Glu/Asp in the SE/DP motif (Wang et al., 2004). Thus, altering the Ser and Pro positions (e.g., Pro–Glu–Ser) in GnRHRm1 increased affinity for GnRH2 but reduced affinity for GnRH1. Similarly, mutating a Ser–Gln–Ser (SQS) motif to SEP in bullfrog type-I GnRHR (ortholog of GnRHRn1) increased GnRH2 affinity and decreased GnRH1 affinity (Wang et al., 2004). For the green monkey type-II GnRHR (ortholog of GnRHRn3/m2), multiple residues in ECL3 and transmembrane domain 7 are involved in discriminating between GnRH2 and GnRH1 (Li et al., 2005). Tello et al. (2008) recently demonstrated that zebrafish GnRHR4 (ortholog of GnRHRn1) and GnRHR2 (ortholog of GnRHRn2) exhibit high affinity for both GnRH2 and GnRH3. However, the motifs responsible for such a high affinity binding between these receptors and GnRH3 need to be further clarified.

#### IS A GENETIC ORTHOLOG A FUNCTIONAL ORTHOLOG? NEOFUNCTIONALIZATION, SUBFUNCTIONALIZATION, AND DYSFUNCTIONALIZATION OF PARALOGS

In mammals, GnRH1 and GnRHRm1 are critical for the onset of puberty and control of reproductive functions. GnRH1-induced activation of the HPG axis is regulated by feedback action from steroid hormones secreted by the gonad. Recently, KiSS1 neurons in the hypothalamus were suggested to mediate this steroid action. KiSS1 neurons are largely distributed in the steroid receptor-enriched APVN of the anterior hypothalamic region and the ARC in the mediobasal hypothalamic region (Kinoshita et al., 2005). The APVN is a potential positive feedback action site for estrogen to control the GnRH1 surge, whereas the ARC is an important negative feedback action area for estrogen to control pulsatile GnRH release (Ohkura et al., 2009).

Although the function of the KiSS/GnRH system in the control of the HPG axis is highly conserved across vertebrate species, there are many examples of KiSS1/GnRH1 paralogs, and not orthologs, functioning in this capacity (Figure 3). In zebrafish, KiSS1 and its receptor KiSS1R are predominantly expressed in the habenula rather than in the hypothalamic area, whereas KiSS2 and KiSS2R are largely distributed in the hypothalamic area (Kitahashi et al., 2009; Servili et al., 2011). This observation suggests that KiSS2 and KiSS2R may be involved in HPG axis regulation. In this species, the KiSS2 peptide is more potent than the KiSS1 peptide at stimulating transcription of GnRH and gonadotropin genes. Furthermore, *KiSS2* expression is more sensitive to estrogen feedback than *KiSS1* expression (Kitahashi et al., 2009; Servili et al., 2011). Thus, in zebrafish, the functional homologs of mammalian *KiSS1* and *KiSS1R* are likely *KiSS2* and *KiSS2R* (Figure 3). With regard to HPG axis control, zebrafish lacks *GnRH1*, suggesting that *GnRH3* may substitute for this function of *GnRH1* (Kah et al., 2007). Salmon species lack *GnRH1*, whereas catfish and eel lack *GnRH3*. Because GnRH1 and GnRH3 neurons are both located in the hypothalamus, it is likely that the two complement one another in these species, so that *GnRH3* replaces the function of *GnRH1* when the latter is lost (e.g., Cypriniformes and most Salmoniformes) and vice versa when *GnRH3* is lost (e.g., catfish and eel; Kah et al., 2007; Okubo and Nagahama, 2008).

Some fish species, such as stickleback and torafugu, and a reptilian species, the anole lizard, lack *KiSS1/KiSS1R*. Therefore, *KiSS2/KiSS2R* in these species may function in a homologous manner to that of mammalian *KiSS1/KiSS1R*. In *Xenopus*, *KiSS2*-expressing neurons are found in the preoptic area and ventromedial hypothalamus, and they send their axons to the median eminence. On the other hand, *KiSS1*-expressing neurons are present only in the ventromedial hypothalamus (Lee et al., 2009). Thus, both *KiSS1* and *KiSS2* are likely involved in the control of the HPG axis in this species, with each gene exerting differential control of the GnRH surge and GnRH pulsatile release (Figure 3). Such dual activity suggests the subfunctionalization of *KiSS1* and *KiSS2* after gene duplication from the ancestral parents. In zebrafish and medaka, *KiSS1* and *KiSS1R* are highly expressed in the habenula, which is not observed in mammals (Kitahashi et al., 2009; Servili et al., 2011), suggesting both genes have become neofunctionalized

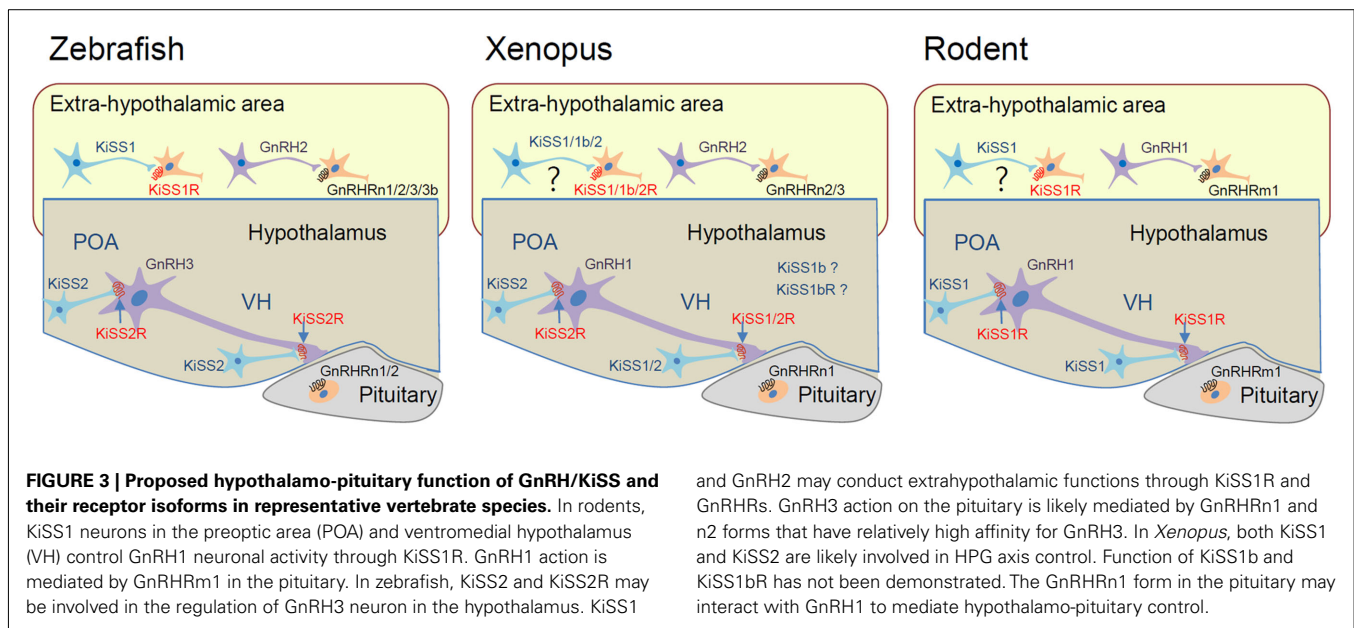

in these species. Alternatively, *KiSS1* and *KiSS1R* may have become dysfunctionalized in the habenula of mammals.

Interestingly, GnRH1 was not a preferred ligand for any of the non-mammalian GnRHRs, and non-mammalian orthologs of GnRHRm1 have not been definitively identified (Kim et al., 2011). Thus, it has been unclear which isoform of GnRHR is utilized for GnRH1 action in the pituitary of non-mammalian species. Although non-mammalian GnRHRs generally have lower affinity for GnRH1 than GnRH2, some such as bullfrog GnRHR1 (GnRHRn1) and zebrafish GnRHR4 (GnRHRn1) exhibit relatively high affinity for GnRH1. Interestingly, bullfrog GnRHR1 is exclusively expressed in the pituitary (Wang et al., 2001; Tello et al., 2008), suggesting it may interact with GnRH1 to mediate HPG axis control. In zebrafish, GnRHR2 (GnRHRn2) and GnRHR4 exhibit a high affinity for GnRH3 (Tello et al., 2008). Considering GnRH1 is absent in zebrafish, GnRH3 may function like GnRH1 in HPG axis control (Figure 3).

The absence of any *KiSS* and *KiSSR* genes in birds raises a fundamental question about the importance of KiSS/KiSSR signaling in vertebrate sexual development and reproduction. A recent finding that ablation of either KiSS1- or KiSS1R-expressing neurons in early development results in the normal onset of puberty in mice suggests these genes may not be required for this activity (Mayer and Boehm, 2011). However, acute ablation of KiSS1- but not KiSSR-expressing cells in adult mice caused an absence of the estrous cycle (Mayer and Boehm, 2011). These observations suggest that KiSS/KiSSR signaling is not the sole system inducing puberty, and that a complementary system can be established in the absence of KiSS1- or KiSSR-expressing cells during puberty. Such a complementary system cannot be established, however, when KiSS1-expressing cells are ablated in the adult period. Whether a complementary system replaces *KiSS* function in birds needs to be further investigated. The lack of any *KiSS/KiSSR* genes in chicken and zebra finch indicates that the KiSS/KiSSR system may be completely dysfunctionalized in birds.

## CONCLUSION

The function of GnRH and GnRHR is critical for sexual maturation and reproduction. The existence of GnRH- and GnRHR-like molecules in early vertebrates and invertebrates tells us that regulation of reproduction is highly conserved in animal phyla (Tello and Sherwood, 2009; Lindemans et al., 2011). Further, comparative analyses of ligand-receptor interaction among various forms of GnRH and GnRHR provide insights into how this ligand-receptor pair coevolved in invertebrates and vertebrates (Tello and Sherwood, 2009). In vertebrates, chromosome/gene duplications have generated multiple paralogous isoforms of GnRH and GnRHR. The presence of lamprey-specific GnRH-I and -III (GnRH4 group), however, reveals more complicated evolutionary scenario of the GnRH gene during early vertebrate evolution (Silver et al., 2004; Kavanaugh et al., 2008). This issue will be further disclosed when genome data of Agnathan and Chondrichthyan species are available. The occurrence of multiple KiSS and KiSSR isoforms has made the regulation of sexual maturation and reproduction in vertebrates even more diverse and complex. Although the amino acid sequences in GnRH and KiSS paralogs have diverged, accompanying amino acid changes have occurred in the cognate receptors, thereby maintaining high selectivity of the ligand-receptor interaction. Some paralogous isoforms acquired a new function, whereas others preserved the ancestral one. In other cases, each paralogous isoform took on a distinct subset of the ancestral functions, complementing each other to fulfill the ancestral function. Finally, some paralogs have been functionally lost, becoming pseudogenes or disappearing completely from the genome. Thus, after duplications of the KiSS and GnRH systems in early vertebrates, the paralogs of KiSS/KiSSR and GnRH/GnRHR became neofunctionalized, subfunctionalized, or dysfunctionalized, and the function related to regulation of reproduction was adopted by either of the *KiSS/GnRH* isoforms during evolution.

## ACKNOWLEDGMENTS

This work was supported by grants (2011K00277) from the Brain Research Center of the Twenty-First Century Frontier Research Program, the Brain Research Program of the National Research

Foundation of Korea (NRF) funded by the Ministry of Education, Science and Technology (2011-0019205), and Science and Technology Medical Research Program to Jae Young Seong and Hubert Vaudry.

## REFERENCES

- Acharjee, S., Do-Rego, J. L., Oh, D. Y., Ahn, R. S., Choe, H., Vaudry, H., Kim, K., Seong, J. Y., and Kwon, H. B. (2004). Identification of amino acid residues that direct differential ligand selectivity of mammalian and nonmammalian V1a type receptors for arginine vasopressin and vasotocin. Insights into molecular coevolution of V1a type receptors and their ligands. *J. Biol. Chem.* 279, 54445–54453.
- Cho, H. J., Acharjee, S., Moon, M. J., Oh, D. Y., Vaudry, H., Kwon, H. B., and Seong, J. Y. (2007). Molecular evolution of neuropeptide receptors with regard to maintaining high affinity to their authentic ligands. *Gen. Comp. Endocrinol.* 153, 98–107.
- Conlon, J. M., and Larhammar, D. (2005). The evolution of neuroendocrine peptides. *Gen. Comp. Endocrinol.* 142, 53–59.
- d'Anglemont de Tassigny, X., Fagg, L. A., Dixon, J. P., Day, K., Leitch, H. G., Hendrick, A. G., Zahn, D., Franceschini, I., Caraty, A., Carlton, M. B., Aparicio, S. A., and Colledge, W. H. (2007). Hypogonadotropichypogonadism in mice lacking a functional Kiss1 gene. *Proc. Natl. Acad. Sci. U.S.A.* 104, 10714–10719.
- de Roux, N., Genin, E., Carel, J. C., Matsuda, F., Chaussain, J. L., and Milgrom, E. (2003). Hypogonadotropic hypogonadism due to loss of function of the Kiss1-derived peptide receptor GPR54. *Proc. Natl. Acad. Sci. U.S.A.* 100, 10972–10976.
- Fernald, R. D., and White, R. B. (1999). Gonadotropin-releasing hormone genes: phylogeny, structure, and functions. *Front. Neuroendocrinol.* 20, 224–240.
- Flanagan, C. A., Becker, II, Davidson, J. S., Wakefield, I. K., Zhou, W., Sealon, S. C., and Millar, R. P. (1994). Glutamate 301 of the mouse gonadotropin-releasing hormone receptor confers specificity for arginine 8 of mammalian gonadotropin-releasing hormone. *J. Biol. Chem.* 269, 22636–22641.
- Fredriksson, R., Lagerstrom, M. C., Lundin, L. G., and Schiöth, H. B. (2003). The G-protein-coupled receptors in the human genome form five main families. Phylogenetic analysis, paralogon groups, and fingerprints. *Mol. Pharmacol.* 63, 1256–1272.
- Fromme, B. J., Katz, A. A., Roeske, R. W., Millar, R. P., and Flanagan, C. A. (2001). Role of aspartate7.32(302) of the human gonadotropin-releasing hormone receptor in stabilizing a high-affinity ligand conformation. *Mol. Pharmacol.* 60, 1280–1287.
- Hoyle, C. H. (1999). Neuropeptide families and their receptors: evolutionary perspectives. *Brain Res.* 848, 1–25.
- Hrabovszky, E., Kallo, I., Szlavik, N., Keller, E., Merchenthaler, I., and Liposits, Z. (2007). Gonadotropin-releasing hormone neurons express estrogen receptor-beta. *J. Clin. Endocrinol. Metab.* 92, 2827–2830.
- Ikemoto, T., and Park, M. K. (2003). Identification and characterization of the reptilian GnRH-II gene in the leopard gecko, *Eublepharis macularius*, and its evolutionary considerations. *Gene* 316, 157–165.
- Ikemoto, T., and Park, M. K. (2007). Comparative analysis of the pituitary and ovarian GnRH systems in the leopard gecko: signaling crosstalk between multiple receptor subtypes in ovarian follicles. *J. Mol. Endocrinol.* 38, 289–304.
- Kah, O., Lethimonier, C., Somoza, G., Guilgur, L. G., Vaillant, C., and Lareyre, J. J. (2007). GnRH and GnRH receptors in metazoa: a historical, comparative, and evolutive perspective. *Gen. Comp. Endocrinol.* 153, 346–364.
- Kavanaugh, S. I., Nozaki, M., and Sower, S. A. (2008). Origins of gonadotropin-releasing hormone (GnRH) in vertebrates: identification of a novel GnRH in a basalvertebrate, the sealamprey. *Endocrinology* 149, 3860–3869.
- Kim, D. K., Cho, E. B., Moon, M. J., Park, S., Hwang, J. I., Kah, O., Sower, S. A., Vaudry, H., and Seong, J. Y. (2011). Revisiting the evolution of gonadotropin-releasing hormones and their receptors in vertebrates: secrets hidden in genomes. *Gen. Comp. Endocrinol.* 170, 68–78.
- Kinoshita, M., Tsukamura, H., Adachi, S., Matsui, H., Uenoyama, Y., Iwata, K., Yamada, S., Inoue, K., Ohtaki, T., Matsumoto, H., and Maeda, K. (2005). Involvement of central metastin in the regulation of preovulatory luteinizing hormone surge and estrous cyclicity in female rats. *Endocrinology* 146, 4431–4436.
- Kitahashi, T., Ogawa, S., and Parhar, I. S. (2009). Cloning and expression of kiss2 in the zebrafish and medaka. *Endocrinology* 150, 821–831.
- Kotani, M., Dethoux, M., Vandenberghe, A., Communi, D., Vandewinden, J. M., Le Poul, E., Brezillon, S., Tyldesley, R., Suarez-Huerta, N., Vandeput, F., Blanpain, C., Schiffmann, S. N., Vassart, G., and Parmentier, M. (2001). The metastasis suppressor gene KISS-1 encodes kisspeptins, the natural ligands of the orphan G protein-coupled receptor GPR54. *J. Biol. Chem.* 276, 34631–34636.
- Larhammar, D., Lundin, L. G., and Hallbook, F. (2002). The human Hox-bearing chromosome regions did arise by block or chromosome (or even genome) duplications. *Genome Res.* 12, 1910–1920.
- Larsson, T. A., Olsson, F., Sundstrom, G., Lundin, L. G., Brenner, S., Venkatesh, B., and Larhammar, D. (2008). Early vertebrate chromosome duplications and the evolution of the neuropeptide Y receptor gene regions. *BMC Evol. Biol.* 8, 184. doi:10.1186/1471-2148-8-184
- Lee, Y. R., Tsunekawa, K., Moon, M. J., Um, H. N., Hwang, J. I., Osugi, T., Otaki, N., Sunakawa, Y., Kim, K., Vaudry, H., Kwon, H. B., Seong, J. Y., and Tsutsui, K. (2009). Molecular evolution of multiple forms of kisspeptins and GPR54 receptors in vertebrates. *Endocrinology* 150, 2837–2846.
- Li, J. H., Choe, H., Wang, A. F., Maiti, K., Wang, C., Salam, A., Chun, S. Y., Lee, W. K., Kim, K., Kwon, H. B., and Seong, J. Y. (2005). Extracellular loop 3 (EL3) and EL3-proximal transmembrane helix 7 of the mammalian type I and type II gonadotropin-releasing hormone (GnRH) receptors determine differential ligand selectivity to GnRH-I and GnRH-II. *Mol. Pharmacol.* 67, 1099–1110.
- Lindemann, M., Janssen, T., Beets, I., Temmerman, L., Meelkop, E., and Schoofs, L. (2011). Gonadotropin-releasing hormone and adipokinetic hormone signaling systems share a common evolutionary origin. *Front. Endocrinol.* 2:16. doi:10.3389/fendo.2011.00016
- Lundin, L. G. (1993). Evolution of the vertebrate genome as reflected in paralogous chromosomal regions in man and the house mouse. *Genomics* 16, 1–19.
- Mayer, C., and Boehm, U. (2011). Female reproductive maturation in the absence of kisspeptin/GPR54 signaling. *Nat. Neurosci.* 14, 704–710.
- Messenger, S., Chatzidaki, E. E., Ma, D., Hendrick, A. G., Zahn, D., Dixon, J., Thresher, R. R., Malinge, I., Lomet, D., Carlton, M. B., Colledge, W. H., Caraty, A., and Aparicio, S. A. (2005). Kisspeptin directly stimulates gonadotropin-releasing hormone release via G protein-coupled receptor 54. *Proc. Natl. Acad. Sci. U.S.A.* 102, 1761–1766.
- Millar, R., Lowe, S., Conklin, D., Pawson, A., Maudsley, S., Troskie, B., Ott, T., Millar, M., Lincoln, G., Sellar, R., Faurholm, B., Scobie, G., Kuestner, R., Terasawa, E., and Katz, A. (2001). A novel mammalian receptor for the evolutionarily conserved type II GnRH. *Proc. Natl. Acad. Sci. U.S.A.* 98, 9636–9641.
- Millar, R. P., Lu, Z. L., Pawson, A. J., Flanagan, C. A., Morgan, K., and Maudsley, S. R. (2004). Gonadotropin-releasing hormone receptors. *Endocr. Rev.* 25, 235–275.
- Moon, M. J., Kim, H. Y., Park, S., Kim, D. K., Cho, E. B., Park, C. R., You, D. Y., Hwang, J.-I., Kim, K., Choe, H., and Seong, J. Y. (2012). Evolutionarily conserved residues at the GLP-1 receptor core confer ligand-induced receptor activation. *J. Biol. Chem.* doi: 10.1074/jbc.mill.276808. [Epub ahead of print].
- Muir, A. I., Chamberlain, L., Elshourbagy, N. A., Michalovich, D., Moore, D. J., Calamari, A., Szekeres, P. G., Sarau, H. M., Chambers, J. K., Murdock, P., Steplewski, K., Shabon, U., Miller, J. E., Middleton, S. E., Darker, J. G., Larminie, C. G., Wilson, S., Bergsma, D. J., Emson, P., Faull, R., Philpott, K. L., and Harrison, D. C. (2001). AXOR12, a novel human G protein-coupled receptor, activated by the peptide KISS-1. *J. Biol. Chem.* 276, 28969–28975.
- Oakley, A. E., Clifton, D. K., and Steiner, R. A. (2009). Kisspeptin signaling in the brain. *Endocr. Rev.* 30, 713–743.
- Oh, D. Y., Kim, K., Kwon, H. B., and Seong, J. Y. (2006). Cellular and molecular biology of orphan G protein-coupled receptors. *Int. Rev. Cytol.* 252, 163–218.

- Ohkura, S., Uenoyama, Y., Yamada, S., Homma, T., Takase, K., Inoue, N., Maeda, K., and Tsukamura, H. (2009). Physiological role of metastin/kisspeptin in regulating gonadotropin-releasing hormone (GnRH) secretion in female rats. *Peptides* 30, 49–56.
- Ohno, S. (1970). *Evolution by Gene Duplication*. New York: Allen & Unwin Springer-Verlag.
- Ohtaki, T., Shintani, Y., Honda, S., Matsumoto, H., Hori, A., Kanehashi, K., Terao, Y., Kumano, S., Takatsu, Y., Masuda, Y., Ishibashi, Y., Watanabe, T., Asada, M., Yamada, T., Suenaga, M., Kitada, C., Usuki, S., Kurokawa, T., Onda, H., Nishimura, O., and Fujino, M. (2001). Metastasis suppressor gene KiSS-1 encodes peptide ligand of a G-protein-coupled receptor. *Nature* 411, 613–617.
- Okubo, K., and Nagahama, Y. (2008). Structural and functional evolution of gonadotropin-releasing hormone in vertebrates. *Acta Physiol. (Oxf)* 193, 3–15.
- Powell, J. F., Zohar, Y., Elizur, A., Park, M., Fischer, W. H., Craig, A. G., Rivier, J. E., Lovejoy, D. A., and Sherwood, N. M. (1994). Three forms of gonadotropin-releasing hormone characterized from brains of one species. *Proc. Natl. Acad. Sci. U.S.A.* 91, 12081–12085.
- Schally, A. V., Arimura, A., Kastin, A. J., Matsuo, H., Baba, Y., Redding, T. W., Nair, R. M., Debeljuk, L., and White, W. F. (1971). Gonadotropin-releasing hormone: one polypeptide regulates secretion of luteinizing and follicle-stimulating hormones. *Science* 173, 1036–1038.
- Seminara, S. B., Messenger, S., Chatzidakis, E. E., Thresher, R. R., Acierno, J. S. Jr., Shagoury, J. K., Bo-Abbas, Y., Kuohung, W., Schwino, K. M., Hendrick, A. G., Zahn, D., Dixon, J., Kaiser, U. B., Slaugenhaupt, S. A., Gusella, J. F., O'Rahilly, S., Carlton, M. B., Crowley, W. F. Jr., Aparicio, S. A., and Colledge, W. H. (2003). The GPR54 gene as a regulator of puberty. *N. Engl. J. Med.* 349, 1614–1627.
- Servili, A., Le Page, Y., Leprince, J., Caraty, A., Escobar, S., Parhar, I. S., Seong, J. Y., Vaudry, H., and Kah, O. (2011). Organization of two independent kisspeptin systems derived from evolutionary-ancient kiss genes in the brain of zebrafish. *Endocrinology* 152, 1527–1540.
- Silver, M. R., Kawachi, H., Nozaki, M., and Sower, S. A. (2004). Cloning and analysis of the lamprey GnRH-III cDNA from eight species of lamprey representing the three families of Petromyzontiformes. *Gen. Comp. Endocrinol.* 139, 85–94.
- Tello, J. A., and Sherwood, N. M. (2009). Amphioxus: beginning of vertebrate and end of invertebrate type GnRH receptor lineage. *Endocrinology* 150, 2847–2856.
- Tello, J. A., Wu, S., Rivier, J. E., and Sherwood, N. M. (2008). Four functional GnRH receptors in zebrafish: analysis of structure, signaling, synteny and phylogeny. *Integr. Comp. Biol.* 48, 570–587.
- Um, H. N., Han, J. M., Hwang, J. I., Hong, S. I., Vaudry, H., and Seong, J. Y. (2010). Molecular coevolution of kisspeptins and their receptors from fish to mammals. *Ann. N. Y. Acad. Sci.* 1200, 67–74.
- Wang, C., Yun, O., Maiti, K., Oh, D. Y., Kim, K. K., Chae, C. H., Lee, C. J., Seong, J. Y., and Kwon, H. B. (2004). Position of Pro and Ser near Glu7.32 in the extracellular loop 3 of mammalian and non-mammalian gonadotropin-releasing hormone (GnRH) receptors is a critical determinant for differential ligand selectivity for mammalian GnRH and chicken GnRH-II. *Mol. Endocrinol.* 18, 105–116.
- Wang, L., Bogerd, J., Choi, H. S., Seong, J. Y., Soh, J. M., Chun, S. Y., Blomenrohr, M., Troskie, B. E., Millar, R. P., Yu, W. H., McCann, S. M., and Kwon, H. B. (2001). Three distinct types of GnRH receptor characterized in the bullfrog. *Proc. Natl. Acad. Sci. U.S.A.* 98, 361–366.
- Yoo, M. S., Kang, H. M., Choi, H. S., Kim, J. W., Troskie, B. E., Millar, R. P., and Kwon, H. B. (2000). Molecular cloning, distribution and pharmacological characterization of a novel gonadotropin-releasing hormone ([Trp8] GnRH) in frog brain. *Mol. Cell Endocrinol.* 164, 197–204.

**Conflict of Interest Statement:** The authors declare that the research was conducted in the absence of any commercial or financial relationships that could be construed as a potential conflict of interest.

Received: 22 November 2011; accepted: 05 January 2012; published online: 24 January 2012.

Citation: Kim D-K, Cho EB, Moon MJ, Park S, Hwang J-I, Do Rego J-L, Vaudry H and Seong JY (2012) Molecular coevolution of neuropeptides gonadotropin-releasing hormone and kisspeptin with their cognate G protein-coupled receptors. *Front. Neurosci.* 6:3. doi: 10.3389/fnins.2012.00003

This article was submitted to *Frontiers in Neuroendocrine Science*, a specialty of *Frontiers in Neuroscience*.

Copyright © 2012 Kim, Cho, Moon, Park, Hwang, Do Rego, Vaudry and Seong. This is an open-access article distributed under the terms of the Creative Commons Attribution Non Commercial License, which permits non-commercial use, distribution, and reproduction in other forums, provided the original authors and source are credited.