



On the local structure of doubly laced crystals [☆]

Philip Sternberg

Department of Mathematics, University of California, One Shields Avenue, Davis, CA 95616-8633, USA

Received 22 March 2006

Available online 23 October 2006

Abstract

Let \mathfrak{g} be a Lie algebra all of whose regular subalgebras of rank 2 are type $A_1 \times A_1$, A_2 , or C_2 , and let B be a crystal graph corresponding to a representation of \mathfrak{g} . We explicitly describe the local structure of B , confirming a conjecture of Stembridge.

© 2006 Elsevier Inc. All rights reserved.

Keywords: Crystal bases; Quantum algebras; Representation theory

1. Introduction

Since their introduction by Kashiwara [3,4], crystal bases have proven very useful in the study of representation theory. In particular, given any highest weight integrable module V over a symmetrizable quantum group we can construct a colored directed graph, called a crystal graph, that encodes nearly all the representation theoretic information of V . Alternatively, one may define crystals axiomatically; many examples of axiomatic crystals that do not correspond to any representation of a quantum group are known.

Many explicit combinatorial models have been developed for crystal graphs of representations; two examples are paths in the weight space of the algebra being represented [6,7] and generalized Young tableaux [5]. In all such constructions, the combinatorics of the crystals are defined by global properties. In [9], Stembridge introduced a set of graph theoretic axioms, each of which addresses only local properties of a colored directed graph, that characterizes highest weight crystal graphs that come from representations of simply laced algebras.

[☆] Supported in part by NSF grants DMS-0135345, DMS-0200774, and DMS-0501101.

E-mail address: sternberg@math.ucdavis.edu.

URL: <http://www.math.ucdavis.edu/~sternberg>.

Proposition 2.4.4 of [2] states that a crystal with a unique maximal vertex comes from a representation if and only if it decomposes as a disjoint union of crystals of representations relative to the rank 2 subalgebras corresponding to each pair of edge colors. It therefore suffices to address the problem of locally characterizing crystal graphs for rank 2 algebras. The results of [9] apply to the algebras $A_1 \times A_1$ and A_2 ; the obvious next case to consider is $C_2 \simeq B_2$. In the sequel we call an algebra doubly laced if all of its regular rank 2 subalgebras are of type $A_1 \times A_1$, A_2 , or C_2 . At the end of [9], Stembridge conjectures the following, which we prove in this paper:

Theorem 1. *Let \mathfrak{g} be a doubly laced algebra, let B be the crystal graph of an irreducible highest weight module of \mathfrak{g} , and let v be a vertex of B such that $e_i v \neq 0$ and $e_j v \neq 0$, where e_i and e_j denote two different Kashiwara raising operators. Then one of the following is true:*

- (1) $e_i e_j v = e_j e_i v$,
- (2) $e_i e_j^2 e_i v = e_j e_i^2 e_j v$ and no other sequences of the operators e_i, e_j with length less than or equal to four satisfy such an equality,
- (3) $e_i e_j^3 e_i v = e_j e_i e_j e_i e_j v = e_j^2 e_i^2 e_j v$ and no other sequences of the operators e_i, e_j with length less than or equal to five satisfy such an equality,
- (4) $e_i e_j^3 e_i^2 e_j v = e_i e_j^2 e_i e_j e_i e_j v = e_j e_i^2 e_j^3 e_i v = e_j e_i e_j e_i e_j^2 e_i v$ and no other sequences of the operators e_i, e_j with length less than or equal to seven satisfy such an equality.

The equivalent statement with f_i and f_j in place of e_i and e_j also holds.

We say in these respective cases that v has a degree 2 relation, a degree 4 relation, a degree 5 relation, or a degree 7 relation above it. These may be viewed as combinatorial analogues of the Serre relations, as observed in [9]. The reader should note that several of the equalities in the description of degree 5 and degree 7 relations correspond to degree 2 relations within the sequences of operators.

It suffices to show that Theorem 1 holds for C_2 crystals; thanks to the result of [2] mentioned above, combined with the results of [9], the statement automatically extends to crystals corresponding to representations of any doubly laced algebra; these algebras are $B_n, C_n, F_4, B_n^{(1)}, C_n^{(1)}, F_4^{(1)}, A_n^{(2)}, A_n^{(2)\dagger}, D_{n+1}^{(2)}$, and $E_6^{(2)}$.

It should be noted that Theorem 1 does not provide a local characterization of crystals coming from representations of the above mentioned algebras. In order to have such a characterization, it would be necessary to provide axioms such as those in Section 1 of [9] and to show that any graph satisfying those axioms is in fact a crystal. Here, we only show the other half of the characterization; we are assured that any graph with a relation not explicitly described in the above theorem is in fact not a crystal over one of these algebras.

2. Background on C_2 crystals

Recall that a crystal is a colored directed graph in which we interpret an i -colored edge from the vertex x to the vertex y to mean that $f_i x = y$ and $e_i y = x$, where e_i and f_i are Kashiwara crystal operators. The vector representation of C_2 has the following crystal:

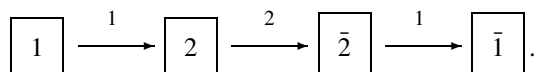

We realize crystals using tableaux filled with the letters $\{1, 2, \bar{2}, \bar{1}\}$ with the total ordering $1 < 2 < \bar{2} < \bar{1}$. The following definition is adapted from that in [5].

Definition 1. A C_2 Young diagram is a partition with no more than two parts; we draw it as a left-justified two-row arrangement of boxes such that the second row is no longer than the first.

A C_2 tableau is a filling of a C_2 Young diagram by the letters of the above alphabet with the following properties:

- (1) each row is weakly increasing by the ordering in the vector representation;
- (2) each column is strictly increasing by the ordering in the vector representation;
- (3) no column may contain 1 and $\bar{1}$ simultaneously;
- (4) the configuration

2	*
*	$\bar{2}$

does not appear in T .

Definition 2. Let T be a type C_2 tableau. The column word W of T is the word on the alphabet $\{1, 2, \bar{2}, \bar{1}\}$ consisting of cd for each column

d
c

in T , reading left to right, then followed by each entry appearing in a one-row column in T , again reading left to right. (This could be called the “reverse far-east reading,” as the column word is precisely the reverse of the “far-east reading” used in [1].)

We now present a definition of the 1-signature and 2-signature of the column word of a type C_2 tableau, which is easily seen to be equivalent to the conventional definitions (e.g. [1]). Our definition differs by using the extra symbol $*$ to keep track of vacant spaces in the signatures. As in Definition 2, our signatures are in the reverse order from those in [1].

Definition 3. Let a be in the alphabet $\{1, 2, \bar{2}, \bar{1}\}$. Then the 1-signature of a is

- $-$, if a is $\bar{2}$ or 1;
- $+$, if a is $\bar{1}$ or 2.

The 2-signature of a is

- $-$, if a is 2;
- $+$, if a is $\bar{2}$;
- $*$, if a is 1 or $\bar{1}$.

Let W be the column word of a type C_2 tableau T . Then for $i \in \{1, 2\}$ the i -signature of T is the word on the alphabet $\{+, -, *\}$ that results from concatenating the i -signatures of the entries of W .

Definition 4. Let $S = s_1 s_2 \cdots s_\ell$ be a signature in the sense of Definition 3. The reduced form of S is the word on the alphabet $\{+, -, *\}$ that results from iteratively replacing every occurrence of $+\underbrace{* \cdots *}_k-$ in S with $\underbrace{* \cdots *}_{k+2}$ until there are no occurrences of $+\underbrace{* \cdots *}_k-$ in S .

The result of applying the Kashiwara operator e_i to a tableau T breaks into several cases. If there are no $+$'s in the reduced form of the i -signature of T , we say that $e_i T = 0$, where 0 is a formal symbol. Otherwise, let a be the entry corresponding to the leftmost $+$ in the reduced form of the i -signature of T . Then $e_i T$ is the tableau that results from changing a to $e_i a$ in T .

Similarly for f_i , if there are no $-$'s in the reduced form of the i -signature of T , we say that $f_i T = 0$. Otherwise, let a be the entry corresponding to the rightmost $-$ in the reduced form of the i -signature of T . Then $f_i T$ is the tableau that results from changing a to $f_i a$ in T .

Lemma 1. *To prove Theorem 1, it suffices to prove only the statement regarding e_i and e_j .*

Proof. For any type C_2 irreducible highest weight crystal B corresponding to the module V , there is a dual crystal B^* corresponding to the module V^* . These crystals are related as follows;

- map the highest weight vertex u_B of B to the lowest weight vertex ℓ_{B^*} of B^* ,
- if $v \in B$ is mapped to $w \in B^*$, map $f_i v$ to $e_i w$.

It is immediate that if the statement regarding e_i and e_j in Theorem 1 holds, the corresponding statement regarding f_i and f_j holds as well. \square

3. Analysis of generic C_2 tableau

A generic C_2 tableau is of the form

$$\begin{array}{|c|c|c|c|c|c|c|c|c|c|c|c|c|c|} \hline
 1 & \cdots & 1 & 1 & \cdots & 1 & 2 & 2 & \cdots & 2 & \bar{2} & \cdots & \bar{2} & \bar{1} & \cdots & \bar{1} \\ \hline
 2 & \cdots & 2 & \bar{2} & \cdots & \bar{2} & \bar{2} & \bar{1} & \cdots & \bar{1} & \bar{1} & \cdots & \bar{1} & & & \\ \hline
 \end{array} \tag{1}$$

where

- any column may be omitted;
- any of the columns other than

$$\begin{array}{|c|} \hline 2 \\ \hline \bar{2} \\ \hline
 \end{array}$$

- may be repeated an arbitrary number of times;
- the bottom row may be truncated at any point.

We are interested in how the Kashiwara operators e_1 and e_2 act on this tableaux, so we must determine where the left-most $+$ appears in the reduced form of the signatures of the tableau. The relevant $+$'s in the signatures of a generic tableau naturally fall into two groups as described by Definition 5.

Definition 5. Let T be a C_2 tableau.

- We define the left block of $+$'s in the 1-signature of T to be those $+$'s from 2 's in the top row and $\bar{1}$'s in the bottom row. If no such entries appear in T , we say that the left block of

+’s in the 1-signature of T has size 0 and its left edge is located on the immediate left of symbol coming from the leftmost $\bar{2}$ or $\bar{1}$ in the top row of T . If there is furthermore no such entry, its left edge is located at the right end of the 1-signature of T .

- We define the right block of +’s in the 1-signature of T to be those +’s from $\bar{1}$ in the top row of T . If no such entry appears in T , we say that the right block of +’s in the 1-signature of T has size 0 and its left edge is located at the right end of the 1-signature of T .
- We define the left block of +’s in the 2-signature of T to be those +’s from $\bar{2}$ in the bottom row. If such an entry does not appear in T , we say that the left block of +’s in the 2-signature of T has size 0 and its left edge is located on the immediate left of the * in the 2-signature coming from the leftmost $\bar{1}$ in the bottom row of T . If T has no $\bar{1}$ ’s in the bottom row, we say that its left edge is located at the right end of the 2-signature of T .
- We define the right block of +’s in the 2-signature of T to be those +’s from $\bar{2}$ in the top row of T . If such an entry does not appear in T , we say that the right block of +’s in the 2-signature of T has size 0 and its left edge is located on the immediate left of the * in the 2-signature coming from the leftmost $\bar{1}$ in the top row of T . If there are furthermore no $\bar{1}$ ’s in the top row of T , we say that its left edge is located at the right end of the 2-signature of T .

In the above cases when a block of +’s has positive size we say that its left edge is on the immediate left of its leftmost +.

Motivated by this definition, we define the following statistics on a C_2 tableaux T .

- $A(T)$ is the number of $\bar{2}$ ’s in the top row of T ,
- $B(T)$ is the number of 2’s in the top row of T plus the number of $\bar{1}$ ’s in the bottom row of T ,
- $C(T)$ is the number of 2’s in the bottom row of T ,
- $D(T)$ is the number of $\bar{2}$ ’s in the bottom row of T .

Example 1. Let

$$T = \begin{array}{|c|c|c|c|c|} \hline 1 & 1 & 2 & \bar{2} & \bar{2} & \bar{1} \\ \hline 2 & \bar{2} & \bar{2} & \bar{1} & & \\ \hline \end{array}.$$

Then $A(T) = 2$, $B(T) = 2$, $C(T) = 1$, and $D(T) = 2$.

Claim 1.

- If e_1 acts on a tableau T with $A(T) < B(T)$, the entry on which e_1 acts corresponds to a symbol in the left block of +’s in the 1-signature of T .
- If e_1 acts on a tableau T with $A(T) \geq B(T)$, the entry on which e_1 acts corresponds to a symbol in the right block of +’s in the 1-signature of T .
- If e_2 acts on a tableau T with $C(T) < D(T)$, the entry on which e_2 acts corresponds to a symbol in the left block of +’s in the 2-signature of T .
- If e_2 acts on a tableau T with $C(T) \geq D(T)$, the entry on which e_2 acts corresponds to a symbol in the right block of +’s in the 2-signature of T .

We now show that the entries in T on which a sequence $e_{i_1} \cdots e_{i_\ell}$ acts are determined by which blocks of +’s correspond to those entries. To achieve this, we verify that the left edge

of a block of +’s can be changed only by acting on that block of +’s. This goal motivates the following notation.

We write e_1^ℓ to indicate the Kashiwara operator e_1 when applied to a tableau T such that $A(T) < B(T)$ and e_1^r to indicate the Kashiwara operator e_1 when applied to a tableau T such that $A(T) \geq B(T)$. Similarly, we write e_2^ℓ to indicate the Kashiwara operator e_2 when applied to a tableau T such that $C(T) < D(T)$ and e_2^r to indicate the Kashiwara operator e_2 when applied to a tableau T such that $C(T) \geq D(T)$. Note that these are not new operators: we simply use the superscript notation to record additional information about how the operators act on specific tableaux.

Claim 2. *Let T be a tableau such that $e_1^r T \neq 0$. Then the left edges of both the left and right blocks of +’s in the 2-signature of $e_1 T$ and the left edge of the left block of +’s in the 1-signature of $e_1 T$ are in the same place as they are in the signatures of T , and the left edge of the right block of +’s in the 1-signature of $e_1 T$ is one position to the right of that in T .*

Symmetrically, if $e_1^\ell T \neq 0$, the left edges of the blocks in the 2-signature and the right block in the 1-signature are unchanged and the left edge of the left block in the 1-signature moves one position to the right; if $e_2^r T \neq 0$, the left edges of the blocks in the 1-signature and the left block in the 2-signature are unchanged and the left edge of the right block in the 2-signature moves one position to the right; and if $e_2^\ell T \neq 0$, the left edges of the blocks in the 1-signature and the right block in the 2-signature are unchanged and the left edge of the left block in the 2-signature moves one position to the right.

Proof. Let $i = 1$ and $j = 2$ or vice versa, and let $\mathbf{x} = \ell$ and $\mathbf{y} = \mathbf{r}$ or vice versa. It is clear from the combinatorially defined action of e_i on C_2 tableaux that if $e_i^{\mathbf{x}} T \neq 0$, the left edge of the \mathbf{y} block of +’s in the i -signature of $e_i T$ is in the same place as in the i -signature of T , and that the left edge of the \mathbf{x} block of +’s in the i -signature of $e_i T$ is one space to the right of its position in the i -signature of T . We may therefore devote our attention to the j -signature in each of the four cases of concern.

First, consider the case of $e_1^\ell T \neq 0$. By Claim 1, we know that this operator changes a 2 in the top row to a 1 or a $\bar{1}$ in the bottom row to a $\bar{2}$. In the first case, no +’s are added to the 2-signature, and no change is made to those entries of interest to the location of a block of +’s of size 0 in the 2-signature. In the other case, one + is added to the left block of +’s in the 2-signature; this addition is to the right of the left edge of this block. Finally, the right block of +’s in the 2-signature of $e_1 T$ is the same as in the 2-signature of T in any case.

Next, consider the case of $e_1^r T \neq 0$. By Claim 1, we know that this operator changes a $\bar{1}$ in the top row of T into a $\bar{2}$. This adds one + to the right block of +’s in the 2-signature to the right of its left edge and makes no change to the left block of +’s.

Now, consider the case of $e_2^\ell T \neq 0$. By Claim 1, we know that this operator changes a $\bar{2}$ in the bottom row to a 2. This does not contribute a + to either the left or right blocks of the 1-signature of $e_2 T$, nor does it pertain to the location of a block of +’s of size 0 in the 1-signature, so the left edges in this signature are the same as in the 1-signature of T .

Finally, we consider the case of $e_2^r T \neq 0$. By Claim 1, we know that this operator changes a $\bar{2}$ in the top row to a 2. This has the effect of adding a + to the left block of +’s in the 1-signature to the right of the left edge of this block. Finally, the right block of +’s in the 1-signature of $e_2 T$ is the same as in the 1-signature of T . \square

Corollary 1. *Let T be a tableau such that $e_1^\ell T \neq 0$, and let E be a sequence of operators from the set $\{e_1^r, e_2^\ell, e_2^r\}$ such that $ET \neq 0$. Then e_1^ℓ acts on the same entry in T as it does in ET . The symmetric statements corresponding to the cases of Claim 2 hold as well.*

The following four sublemmas state that the relative values of $A(T)$, $B(T)$, $C(T)$, and $D(T)$ not only determine where e_i acts within a tableau, but also what the values of $A(e_i T)$, $B(e_i T)$, $C(e_i T)$, and $D(e_i T)$ are. This will be an invaluable tool for our analysis in Section 4.

Sublemma 1. *Suppose T is a tableau such that e_1 acts on the left block of $+$'s in the 1-signature of T (i.e., such that $A(T) < B(T)$). Then $A(e_1 T) = A(T)$, $B(e_1 T) = B(T) - 1$, and $C(e_1 T) - D(e_1 T) = C(T) - D(T) - 1$.*

Proof. We have two cases to consider; e_1 may act by changing a 2 to a 1 in the top row or a $\bar{1}$ to a $\bar{2}$ in the bottom row. In both of these cases, it is easy to see that the number of $\bar{2}$'s in the top row is unchanged and the number of 2's in the top row plus the number of $\bar{1}$'s in the bottom row is diminished by one; hence $A(e_1 T) = A(T)$ and $B(e_1 T) = B(T) - 1$.

Observe that in the case of a $\bar{1}$ changing into a $\bar{2}$ in the bottom row, the content of the top row is unchanged, but the number of $\bar{2}$'s in the bottom row is increased by 1. In the case of a 2 changing into a 1 in the top row, the bottom row is unchanged, but the number of 2's in the top row is decreased by 1. In both of these cases, we find that $C(e_1 T) - D(e_1 T) = C(T) - D(T) - 1$. \square

Sublemma 2. *Suppose T is a tableau such that e_1 acts on the right block of $+$'s in the 1-signature of T (i.e., such that $A(T) \geq B(T)$). Then $A(e_1 T) = A(T) + 1$, $B(e_1 T) = B(T)$, $C(e_1 T) = C(T)$, and $D(e_1 T) = D(T)$.*

Proof. Since the right block of $+$'s in the 1-signature comes entirely from $\bar{1}$'s in the top row of T , it follows that acting by e_1 changes one of these $\bar{1}$'s into a $\bar{2}$. We immediately see that the number of $\bar{2}$'s in the top row increases by 1, and that the number of 2's in the top row and $\bar{2}$'s and $\bar{1}$'s in the bottom row are all unchanged. \square

Sublemma 3. *Suppose T is a tableau such that e_2 acts on the left block of $+$'s in the 1-signature of T (i.e., such that $C(T) < D(T)$). Then $A(e_2 T) = A(T)$, $B(e_2 T) = B(T)$, $C(e_2 T) = C(T)$, and $D(e_2 T) = D(T) - 1$.*

Proof. The entry on which e_2 acts is a $\bar{2}$ in the bottom row, which will be changed into a 2. We immediately see that the number of $\bar{2}$'s in the bottom row decreases by 1, and that the number of 2's and $\bar{2}$'s in the top row and $\bar{1}$'s in the bottom row are all unchanged. \square

Sublemma 4. *Suppose T is a tableau such that e_2 acts on the right block of $+$'s in the 1-signature of T (i.e., such that $C(T) \geq D(T)$). Then $A(e_2 T) = A(T) - 1$, $B(e_2 T) = B(T) + 1$, $C(e_2 T) = C(T) + 1$, and $D(e_2 T) = D(T)$.*

Proof. In this case e_2 will change a $\bar{2}$ to a 2 in the top row. It is easy to see that the number of 2's in the top row increases by 1 and the number of $\bar{2}$'s in the bottom row is unchanged; hence $C(e_2 T) = C(T) + 1$ and $D(e_2 T) = D(T)$.

Likewise, since the number of $\bar{2}$'s in the top row is decreased by 1 and the number of 2's in the top row is increased by 1, we find that $A(e_2 T) = A(T) - 1$ and $B(e_2 T) = B(T) + 1$. \square

Table 1
Degree of relation over T , given its $ABCD$ statistics

	$A < B$	$A = B$	$A = B + 1$	$A > B + 1$
$C < D$	2	2	2	2
$C = D$	4	7	4	2
$C > D$	2	5	4	2

4. Proof of Theorem 1

We are now equipped to begin addressing Theorem 1. It is proved as a consequence of Lemmas 2 through 8, each of which deals with a certain case of the relative values of $A(T)$, $B(T)$, $C(T)$, and $D(T)$. To see that these cases are exhaustive, refer to Table 1.

Lemma 2. *Suppose T is a tableau such that $C(T) < D(T)$, $e_1T \neq 0$, and $e_2T \neq 0$. Then T has a degree 2 relation above it.*

Proof. From Claim 1, we know that e_2 acts on the left block of +’s, and by Sublemma 3, we know that $A(e_2T) = A(T)$ and $B(e_2T) = B(T)$; it follows that $e_1e_2T \neq 0$, and that e_1 acts on the same entry in e_2T as it does in T . Furthermore, by Sublemmas 1 and 2, we know that either $C(e_1T) - D(e_1T) = C(T) - D(T) - 1$ or $C(e_1T) = C(T)$ and $D(e_1T) = D(T)$; in either case, we still find that $C(e_1T) < D(e_1T)$. Since $C(e_1T) \geq 0$, we are assured that $D(e_1T) \geq 1$, and thus $e_2e_1T \neq 0$. We conclude that e_2 acts on the same entry in e_1T as it does in T . \square

Lemma 3. *Suppose T is a tableau such that $A(T) > B(T) + 1$, $e_1T \neq 0$, and $e_2T \neq 0$. Then T has a degree 2 relation above it.*

Proof. From Claim 1, we know that e_1 acts on the right block of +’s, and by Sublemma 2, we know that $C(e_1T) = C(T)$ and $D(e_1T) = D(T)$; thus $e_2e_1T \neq 0$, and e_2 acts on the same entry in e_1T as it does in T . Furthermore, by Sublemmas 3 and 4, we know that either $A(e_2T) = A(T)$ and $B(e_2T) = B(T)$ or $A(e_2T) = A(T) - 1$ and $B(e_2T) = B(T) + 1$; in either case, we find that $A(e_2T) > B(e_2T)$ and the size of the right block of +’s in the 1-signature is not diminished. We therefore conclude that $e_1e_2T \neq 0$ and that e_1 acts on the same entry in e_2T as it does in T . \square

Lemma 4. *Suppose T is a tableau such that $A(T) < B(T)$, $C(T) > D(T)$, $e_1T \neq 0$, and $e_2T \neq 0$. Then T has a degree 2 relation above it.*

Proof. By Claim 1, we know that e_1 acts on the left block of +’s in T and e_2 acts on the right block of +’s in T . By Sublemma 4, we know that $A(e_2T) = A(T) - 1$ and $B(e_2T) = B(T) + 1$. It follows that $A(e_2T) < B(e_2T)$, and since $A(e_2T) \geq 0$, this ensures that $B(e_2T) \geq 1$, and thus $e_1e_2T \neq 0$. We conclude that e_1 acts on the same entry in e_2T as it does in T . Furthermore, by Sublemma 1, we know that $C(e_1T) - D(e_1T) = C(T) - D(T) - 1$; it follows that $C(e_1T) \geq D(e_1T)$. Since we also know that the size of the right block of +’s in the 2-signature of e_1T is at least as large as that of T , it is the case that $e_2e_1T \neq 0$, and so e_2 acts on the same entry in e_1T as it does in T . \square

To prove Lemmas 5 through 8, we must not only show that the given sequences of operators act on the same entries, but also that no pair of homogeneous sequences of operators (i.e., a pair

Table 2
Legend for Figs. 1 through 6

edge pointing to the right	acting by e_1
edge pointing to the left	acting by e_2
solid edge	acting on the right block of +’s
dashed edge	acting on the left block of +’s
vertex labeled by (d_1, d_2)	tableau T with statistics such that $A(T) = B(T) + d_1$ and $C(T) = D(T) + d_2$

(P_1, P_2) such that P_1 and P_2 have the same number of instances of e_1 and e_2) with shorter or equal length act on the same entries. To assist in our illustration of this fact, we will refer to figures that encode the generic behavior of all sequences of operators on a tableau with content as specified by the hypothesis of each lemma. Table 2 is a legend for the figures used to prove Lemmas 5 through 7. In the picture used to prove Lemma 8, we instead use an edge pointing down to indicate acting by e_1 and an edge pointing up to indicate acting by e_2 ; otherwise the legend is the same.

To assist in proving that the sequences in question do not kill our tableaux, we have the following sublemma.

Sublemma 5. *Let E be a dashed edge from v up to w ; i.e., an operator e_i^ℓ acts on v to produce w . Then $e_i v \neq 0$.*

Proof. The Kashiwara operator e_i acts on the left block of +’s of a tableau T precisely when $A(T) < B(T)$ or $C(T) < D(T)$ in the cases of $i = 1$ or $i = 2$, respectively. Since these numbers are all non-negative integers, we conclude that $B(T) > 0$ or $D(T) > 0$. Since these statistics indicate the number of +’s in the left block of their respective signatures, we are assured that there is an entry on which e_i can act. \square

Thus it suffices to prove that the solid edges in the paths of concern do not produce 0.

Lemma 5. *Suppose T is a tableau such that $A(T) = B(T) + 1$, $C(T) \geq D(T)$, $e_1 T \neq 0$, and $e_2 T \neq 0$. Then T has a degree 4 relation above it.*

Proof. We must first confirm that the sequences $e_1 e_2^2 e_1$ and $e_2 e_1^2 e_2$ do not produce 0 when applied to T . First, observe that since e_1 acts on the right block of +’s in T , it changes a $\bar{1}$ to a $\bar{2}$ in the top row. This adds a + to the reduced 2-signature of the tableaux, so we know that $e_2^2 e_1 T \neq 0$. By Sublemma 5, we know that $e_1 e_2^2 e_1 T \neq 0$. On the other hand, we know that e_2 acts on T by changing a $\bar{2}$ to a 2 in the top row; this means that the reduced 1-signature of $e_2 T$ has a single + in the left block and its right block has at least one +, as did the 1-signature of T . We conclude that $e_1^2 e_2 T \neq 0$. We know that in $e_1 e_2 T$, e_1 changes a $\bar{1}$ to a $\bar{2}$ in the top row; since the +’s in the 2-signature from this entry cannot be paired with any –’s, we conclude that $e_2 e_1^2 e_2 T \neq 0$.

Now that we know that neither of these sequences produces 0 when applied to T , it is clear that we have $e_1 e_2^2 e_1 T = e_2 e_1^2 e_2 T$, as the paths P_1 and P_2 leading from the base of the graph in Fig. 1 to the indicated leaves both have one solid right edge, one dashed right edge, and two solid left edges. We must now confirm that among all pairs (Q_1, Q_2) of increasing paths from the base in these graphs such that Q_1 begins by following the left edge and Q_2 begins by following the right edge, (P_1, P_2) is the only pair with the same number of each type of edge.

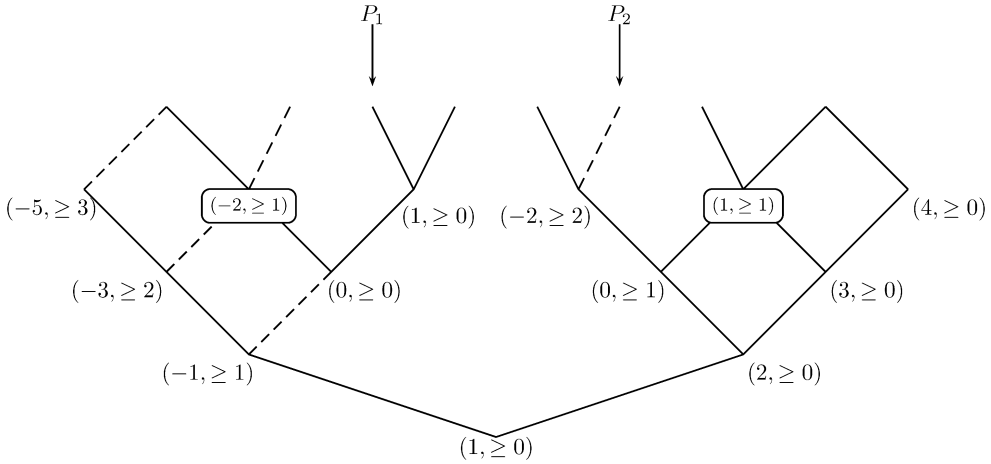

Fig. 1. Picture for Lemma 5.

Since the right edge from the base of the graph is solid, our candidate for Q_1 must have a solid right edge. Inspecting the graph tells us that this path must begin with the path corresponding to $e_1^2 e_2$. This path has a dashed right edge, and the only candidate for Q_2 with this feature is in fact P_2 , which has two solid left edges. The only way to extend $e_1^2 e_2$ to have the same edge content as P_2 is by extending it to P_1 . \square

Lemma 6. *Suppose T is a tableau such that $A(T) < B(T)$, $C(T) = D(T)$, $e_1 T \neq 0$, and $e_2 T \neq 0$. Then T has a degree 4 relation above it.*

Proof. We must first confirm that the sequences $e_1 e_2^2 e_1$ and $e_2 e_1^2 e_2$ do not produce 0 when applied to T . By Sublemma 5 it suffices to show that $e_2^2 e_1 T \neq 0$, since $e_2 T \neq 0$ by assumption and all other edges in P_1 and P_2 are dashed. To see this, simply observe that there is at least one + in the right block of the reduced 2-signature of T ; the sequence $e_2 e_1$ acts on the left blocks of +’s, so the corresponding entry remains available for e_2 to act on.

Now that we know that neither of these sequences produces 0 when applied to T , it is clear that we have $e_1 e_2^2 e_1 T = e_2 e_1^2 e_2 T$, as the paths P_1 and P_2 leading from the base of the graph in Figs. 2 through 4 to the indicated leaves have two dashed right edges, one solid left edge, and one dashed left edge. We must now confirm that among all pairs (Q_1, Q_2) of increasing paths from the base in these graphs such that Q_1 begins by following the left edge and Q_2 begins by following the right edge, (P_1, P_2) is the only pair with the same number of each type of edge.

This is easy to see by the following argument. Every candidate for Q_2 (i.e., every path in the right half of the graphs in Figs. 2 through 4) has at least one dashed left edge. The only candidate for Q_1 (i.e., the only path in the left half of the graphs in Figs. 2 through 4) with a dashed left edge is P_1 . By inspecting Figs. 2 through 4, P_2 is the only candidate for Q_2 with two dashed right edges and one solid left edge. \square

Lemma 7. *Suppose T is a tableau such that $A(T) = B(T)$, $C(T) \geq D(T) + 1$, $e_1 T \neq 0$, and $e_2 T \neq 0$. Then T has a degree 5 relation above it.*

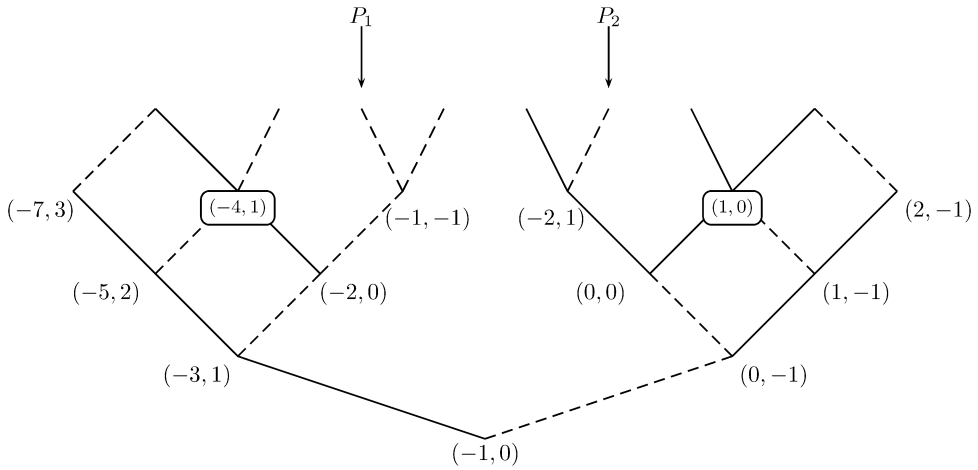

Fig. 2. Picture 1 for Lemma 6.

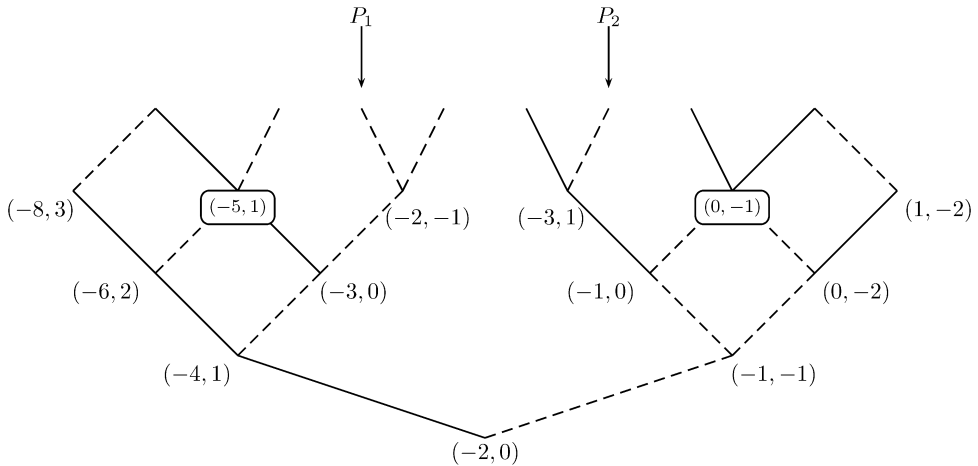

Fig. 3. Picture 2 for Lemma 6.

Proof. We must first confirm that the sequences $e_2e_1^3e_2$ and $e_1e_2e_1e_2e_1$ do not produce 0 when applied to T . First, note that there is at least one + in the right block of the reduced 1-signature of T . Since e_2 acts on the right block of +’s in the 2-signature of T , there are as many +’s in the right block of the 1-signature of e_2T as in that of e_1T . Observe that $A(e_2T) = B(e_2T) - 2$, so we know that there are additionally two +’s in the left block of the reduced 1-signature of e_2T . This implies that $e_1^3e_2T \neq 0$. The third of these applications of e_1 changes a $\bar{1}$ to a $\bar{2}$ in the top row; the + in the 2-signature of $e_1^3e_2T$ entry cannot be bracketed, so we know that $e_2e_1^3e_2T \neq 0$. On the other hand, we know that the right block of the reduced 2-signature of T has at least one +. Since e_1 changes a $\bar{1}$ to a $\bar{2}$ in the top row of T , we know that e_2 will change this entry to a 2 so that the right block of the reduced signature of e_1T has at least two +’s that cannot be bracketed by -’s. The leftmost of these entries will be acted upon by e_2 , so $e_2e_1T \neq 0$. Furthermore, since $A(e_2e_1T) = B(e_2e_1T) - 1$, we know that $e_1e_2e_1T \neq 0$. At

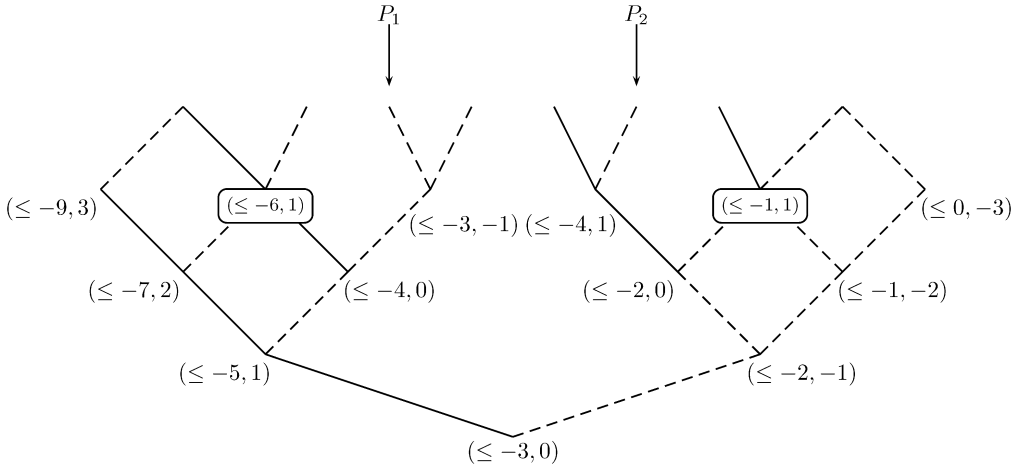

Fig. 4. Picture 3 for Lemma 6.

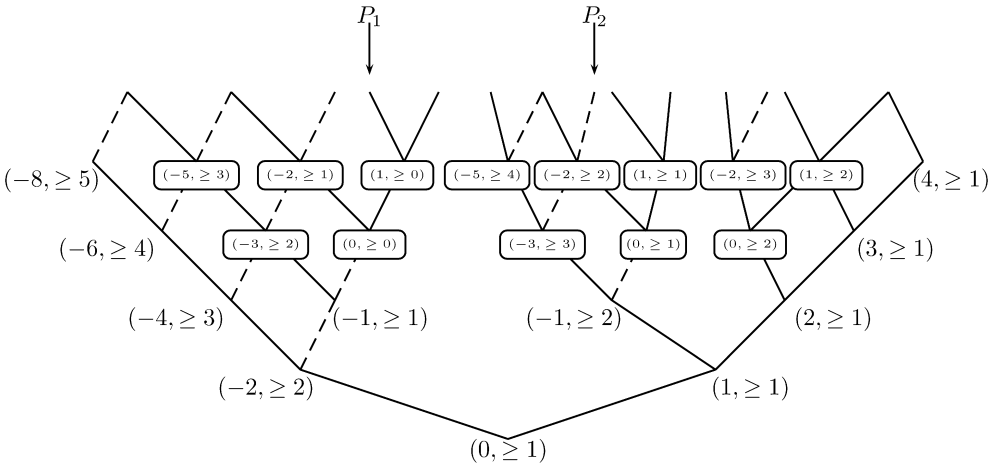

Fig. 5. Picture for Lemma 7.

least one + remains in the right block of the reduced 2-signature of $e_1e_2e_1T$, so $e_2e_1e_2e_1T \neq 0$. Finally, since $A(e_2e_1e_2e_1T) = B(e_2e_1e_2e_1T) - 2$, we know that $e_1e_2e_1e_2e_1T \neq 0$.

Now that we know that neither of these sequences produces 0 when applied to T , it is clear that we have $e_2e_1^3e_2T = e_1e_2e_1e_2e_1T$, since the paths P_1 and P_2 leading from the base of the graph in Fig. 5 to the indicated leaves have no solid left edges, two dashed left edges, one solid right edge, and two dashed right edges. Note that these paths are equivalent to $e_1^2e_2^2e_1T$, due to the degree 2 relation above e_2e_1T ; we may denote this alternative path by P'_2 . We must now confirm that among all pairs (Q_1, Q_2) of increasing paths from the base in these graphs such that Q_1 begins by following the left edge and Q_2 begins by following the right edge, (P_1, P_2) and (P_1, P'_2) are the only pairs with the same number of each of the above types of edges.

Since the right edge from the base of the graph is solid, our candidate for Q_1 must have a solid right edge. Observe that all paths in the left half of this graph with at least one solid right edge have two dashed right edges. The only candidates for Q_2 with two dashed edges are P_2 and P'_2 ,

both of which have two dashed left edges. The only remaining candidate for Q_1 with two dashed left edges is in fact P_1 . \square

Lemma 8. *Suppose T is a tableau such that $A(T) = B(T)$, $C(T) = D(T)$, $e_1T \neq 0$, and $e_2T \neq 0$. Then T has a degree 7 relation above it.*

Proof. Note that in order to increase the readability of the graph in Fig. 6, it has been oriented to grow to the right rather than up. We therefore take a down edge to indicate acting by e_1 and an up edge to indicate acting by e_2 . Otherwise, the legend from Table 2 applies.

We must first confirm that the sequences $e_2e_1^2e_2^3e_1$ and $e_1e_2^3e_1^2e_2$ do not produce 0 when applied to T . By Sublemma 5, we need only show that $e_1^3e_2T$, $e_2^2e_1^3e_2T$, and $e_2^2e_1T$ are not 0. First note that there is at least one $\bar{1}$ in the top row of T , and the application of e_1^2 to e_2T acts on entries corresponding to the left block of $+$'s. It follows that the $\bar{1}$'s in the top row of T are also present in $e_1^2e_2T$, so $e_1^3e_2T \neq 0$. This final application of e_1 changes a $\bar{1}$ to a $\bar{2}$. Since e_2 acts on the left block of $+$'s in $e_1^3e_2T$, it leaves this $\bar{2}$ alone, and it can be acted on by the next application of e_2 , so $e_2^2e_1^3e_2T \neq 0$. Finally, note that there is a $\bar{2}$ in the top row of T and e_1 changes a $\bar{1}$ to a $\bar{2}$ in the top row of T . Thus, there are at least two $\bar{2}$'s in the top row of e_1T , and $e_2^2e_1T \neq 0$.

Now that we know that neither of these sequences produces 0 when applied to T , it is clear that we have $e_2e_1^2e_2^3e_1T = e_1e_2^3e_1^2e_2T$, since the paths corresponding to these sequences leading from the base of the graph in Fig. 6 to the leaves marked by arrows have one solid down edge, three dashed down edges, two solid up edges, and one dashed up edge. Note that these paths are equivalent to $e_2e_1e_2e_1e_2^2e_1T = e_1e_2^2e_1e_2e_1e_2T$, due to the degree 2 relations above $e_2^2e_1T$ and e_1e_2T ; we denote these alternative paths by P'_1 and P'_2 , respectively. We must now confirm that among all pairs (Q_1, Q_2) of increasing paths from the base in these graphs such that Q_1 begins by following the up edge and Q_2 begins by following the down edge, (P_1, P_2) , (P_1, P'_2) , (P'_1, P_2) and (P'_1, P'_2) , are the only pairs with the same number of each of the above types of edges.

We first address pairs of paths of length no greater than 5. For a path to be a candidate for Q_1 , it must have at least one solid down edge. The only such paths are those beginning with $e_1^2e_2T$. As these paths have two dashed down edges, their only possible Q_2 mate is $e_1^2e_2^2e_1T$, but none of our Q_1 candidates have the same edge content as this path.

We now consider paths of length 6. As in the preceding paragraph, our only candidates for Q_1 are those paths that contain a solid down edge and begin with $e_1^2e_2T$; all such paths have exactly two dashed down edges. Up to degree 2 relations, there are three candidates for Q_2 : $e_1^2e_2^3e_1T$, $e_1e_2e_2^2e_1e_2T$, and $e_1^2e_2^2e_1^2T$. None of these paths contain a dashed up edge, which leaves only $e_1^5e_2T$ as our only candidate for Q_1 ; this cannot be paired with any of our three potential Q_2 paths.

Finally, we restrict our attention to paths of length 7. There are six paths (again, up to degree 2 relations) in the top half of the graph with solid down edges: $e_1^5e_2^2T$ and those paths beginning with $e_1^3e_2T$. The former has four dashed down edges, a feature lacking from all paths in the bottom half of the graph. We may also exclude from our consideration $e_1^6e_2T$, as all candidates for Q_2 with only one up edge have at most one dashed down edge.

The remaining three paths that might be Q_1 all have a dashed up edge; the only Q_2 candidates with this feature are P_2 and P'_2 . The only paths in the top half of the graph with the same edge content as these are P_1 and P'_1 . \square

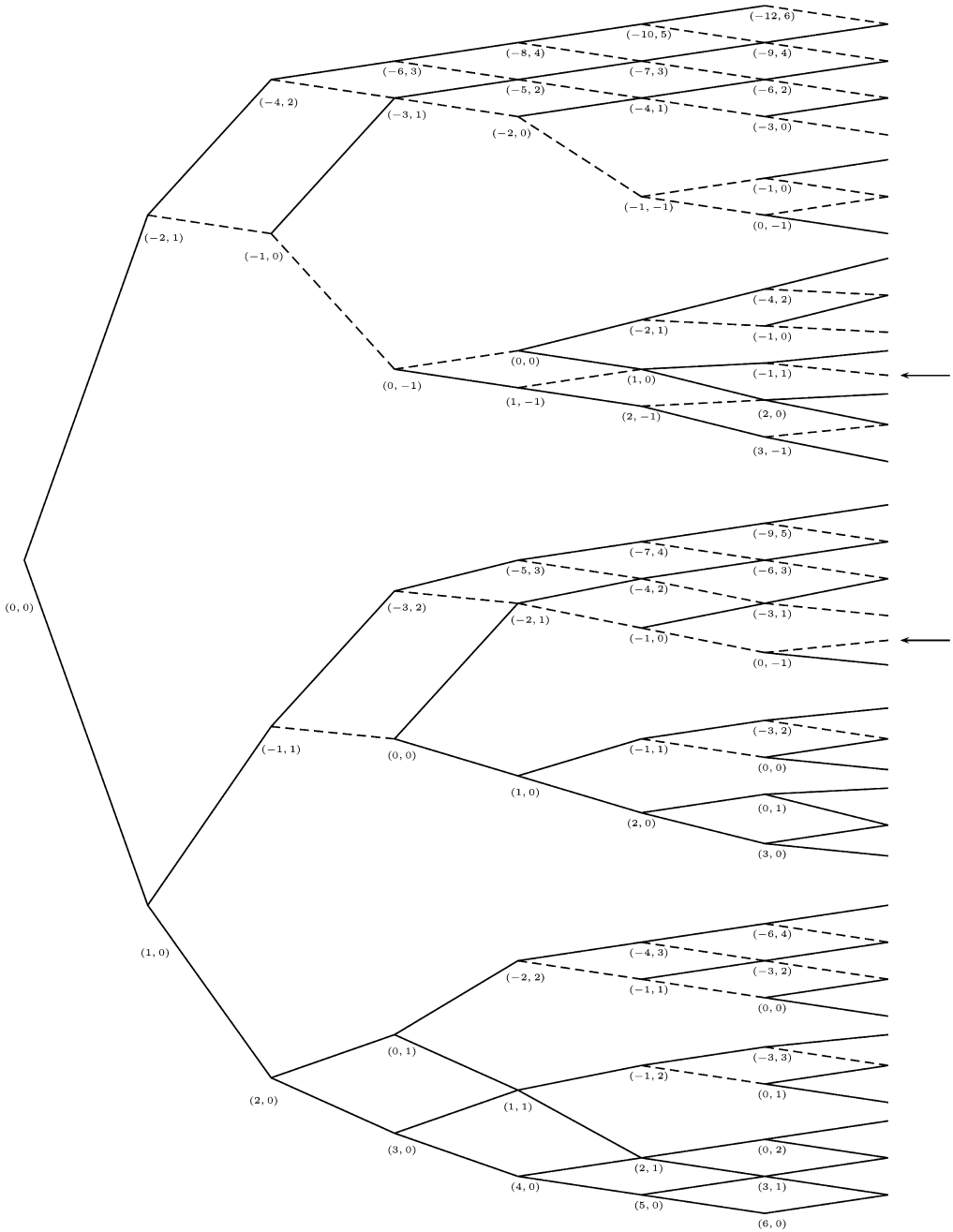

Fig. 6. Picture for Lemma 8.

Example 2. In Fig. 7, we have a crystal in which the bottom tableau T has the statistics $A(T) = 1 = B(T)$ and $C(T) = 0 = D(T)$, illustrating Lemma 8.

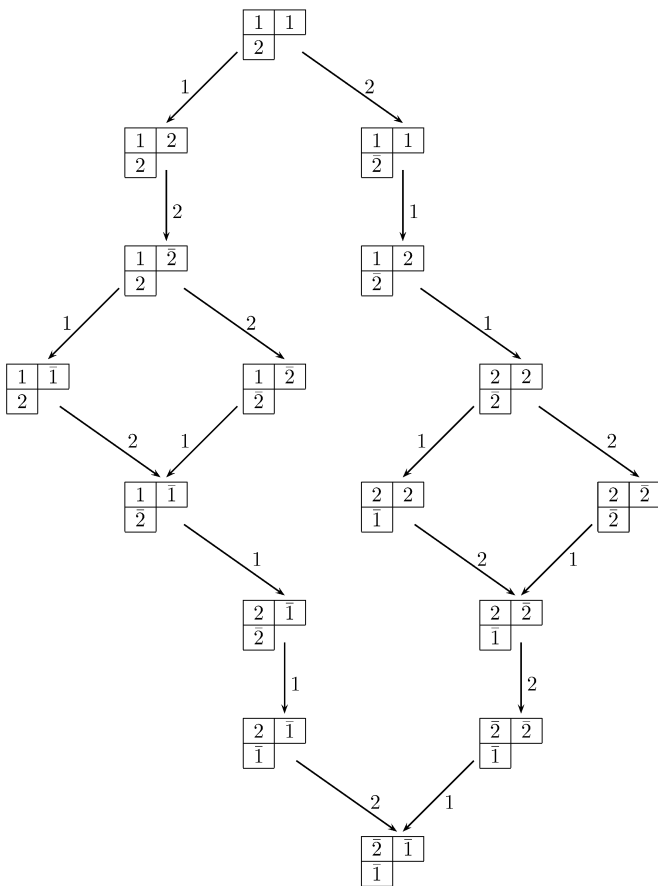

Fig. 7.

5. Further work

In the program to locally characterize crystal graphs, two questions immediately arise following this result. First, can a local characterization be provided for doubly laced crystals? And second, could such a result be provided for triply laced crystals (i.e., those of type G_2)?

It is very reasonable to suspect that a set of local graph theoretic axioms that characterize doubly laced crystals exists. It appears that they may need to be “less local” than the axioms in [9] for simply laced crystals. For instance, we have seen that when T has a degree 5 relation above it, there is a degree 2 relation above e_2e_1T . Thus, one of these axioms might be of the form: “If v is a vertex satisfying certain local conditions, then v must have a degree 5 relation above it and e_2e_1v must have a degree 2 relation above it.”

It may be possible to prove that such a set of axioms characterize doubly laced crystals by using virtual crystals [8], a construction that realizes non-simply laced crystals in terms of embeddings into simply laced crystals. More precisely, one can construct a “virtualization” of each of the relations dealt with above; each of these would be a local piece of a type A_3 crystal that corresponds to these relations in terms of the virtual crystal embeddings. It would then suffice

to show that when these virtual pieces are assembled according to the doubly-laced axioms, the simply laced axioms are satisfied.

Calculations suggest that there are over 40 different relations in the case of G_2 crystals, some of degree greater than 10 [10]. The methods employed here would clearly be inadequate to produce a human-readable proof of a local description of such graphs. However, there are probably statistics on G_2 Littelmann paths similar to the $ABCD$ statistics used here that could be used to reduce the problem to a finite number of cases; these could, in turn, be checked by computer.

Acknowledgments

The author thanks Anne Schilling for suggesting this problem and for helpful discussions, John Stembridge for very helpful correspondence on this topic, and Eric Rains and one of the referees for the suggestion of working with crystals of type C_2 rather than those of type B_2 .

References

- [1] J. Hong, S.-J. Kang, Introduction to Quantum Groups and Crystal Bases, Grad. Stud. Math., vol. 42, Amer. Math. Soc., Providence, RI, ISBN 0-8218-2874-6, 2002, xviii+307 pp.
- [2] S.-J. Kang, M. Kashiwara, K.C. Misra, T. Miwa, T. Nakashima, A. Nakayashiki, Affine crystals and vertex models, in: Infinite Analysis, Parts A, B, Kyoto, 1991, in: Adv. Ser. Math. Phys., vol. 16, World Scientific, River Edge, NJ, 1992, pp. 449–484.
- [3] M. Kashiwara, Crystalizing the q -analogue of universal enveloping algebras, Comm. Math. Phys. 133 (2) (1990) 249–260.
- [4] M. Kashiwara, On crystal bases of the q -analogue of universal enveloping algebras, Duke Math. J. 63 (2) (1991) 465–516.
- [5] M. Kashiwara, T. Nakashima, Crystal graphs for representations of the q -analogue of classical Lie algebras, J. Algebra 165 (2) (1994) 295–345.
- [6] P. Littelmann, A Littlewood–Richardson rule for symmetrizable Kac–Moody algebras, Invent. Math. 116 (1994) 329–346.
- [7] P. Littelmann, Paths and root operators in representation theory, Ann. of Math. 142 (1995) 499–525.
- [8] M. Okado, A. Schilling, M. Shimozono, Virtual crystals and fermionic formulas of type $D_{n+1}^{(2)}$, $A_{2n}^{(2)}$, and $C_n^{(1)}$, Represent. Theory 7 (2003) 101–163.
- [9] J. Stembridge, A local characterization of simply-laced crystals, Trans. Amer. Math. Soc. 355 (2003) 4807–4823.
- [10] J. Stembridge, personal communication, January 2006.