

<Technical Note>

HIGH COOLING WATER TEMPERATURE EFFECTS ON DESIGN AND OPERATIONAL SAFETY OF NPPS IN THE GULF REGION

BYUNG KOO KIM^{1*} and YONG HOON JEONG^{1,2}

¹Khalifa University

PO Box 127788, Abu Dhabi, UAE

²Korea Advanced Institute of Science and Technology

291 Daehak-ro, Yuseong-Gu, Daejeon, 305-701, Republic of Korea

*Corresponding author. E-mail : bkkim9@gmail.com

Received October 30, 2012

Accepted for Publication June 07, 2013

The Arabian Gulf region has one of the highest ocean temperatures, reaching above 35 degrees and ambient temperatures over 50 degrees in the summer. Two nuclear power plants (NPP) are being introduced in the region for the first time, one at Bushehr (1,000 MWe PWR plant from Russia), and a much larger one at Barakah (4X1,400 MWe PWR from Korea). Both plants take seawater from the Gulf for condenser cooling, having to modify the secondary/tertiary side cooling systems design by increasing the heat transfer surface area from the country of origin. This paper analyses the secondary side of a typical PWR plant operating under the Rankine cycle with a simplified thermal-hydraulic model. Parametric study of ocean cooling temperatures is conducted to estimate thermal efficiency variations and its associated design changes for the secondary side. Operational safety is reviewed to deliver rated power output with acceptable safety margins in line with technical specifications, mainly in the auxiliary systems together with the cooling water temperature. Impact on the Gulf seawater as the ultimate heat sink is considered negligible, affecting only the adjacent water near the NPP site, when compared to the solar radiation on the sea surface.

KEYWORDS : UAE Nuclear Power Plant, High Seawater Temperature, Barakah, Gulf Nuclear, Operational Safety

1. INTRODUCTION

The Arabian Gulf is a semi-enclosed, marginal sea that is exposed to an arid, sub-tropical climate bordering Iraq, Iran on the northern shore, Kuwait, Saudi Arabia, Bahrain, Qatar, UAE, and Oman on the southern shore (all Gulf Cooperation Council 6 countries). The Arabian Gulf is approximately 990 km long with a maximum width of 370 km, occupying a surface area of approximately 239,000 km² with an average depth of 36 m.

Compared to the Red Sea on the western side of the Arabian Peninsula, the surface area of the Gulf is about half, but the volume of water is less than 1/20 of the Red Sea due to the depth differences. Extensive shallow regions are found along the coast of the UAE with an average depth of less than 20 m, known as Southern Shallows, while deeper regions are found along the northern shore from the Iranian coast into the Strait of Hormuz and the Gulf of Oman. (Refer to *Figure 1. General Bathymetry map of the Arabian Gulf*) A relatively high evaporation rate, combined with a restricted exchange of sea currents

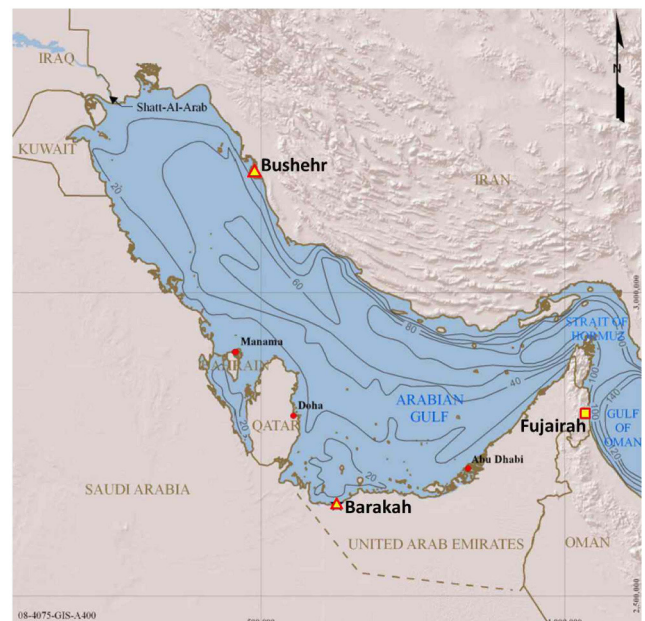

Fig. 1. General Bathymetry Map of the Arabian Gulf, with Bushehr (Northern Shore) and Barakah (Southern Shore) NPPs (Reference: ESRI 2008, *World Shaded Relief Imagery*, June 2008)

from the Indian Ocean, leads to the formation of a dense, saline water mass and a reverse estuary circulation through the Strait of Hormuz. The Gulf and the Red Sea are two of the most saline water masses found in the world's oceans, with average salinity of 40-50‰ (the world ocean average is 35‰). The dense, saline Gulf water enters the Indian Ocean in exchange flows through the narrow, shallow Strait of Hormuz as dense bottom currents. Mixing of the Gulf water from tides and sea currents is limited along the coastal zones except for the Strait of Hormuz area [1].

The mean annual ambient temperature in the UAE is 28.0°C. The winter temperature regime is characterized by warm and sunny weather where daytime temperatures average 23.0°C, but the summer climate is characterized by high temperatures and high humidity. These summer air temperatures are often above 38.0°C, but during spells of high humidity the temperatures can be as high as 49.0°C. These temperatures can be even higher (over 50.0°C) in the northern part of the Gulf, making the region one of the hottest places on the globe. Humidity in coastal areas averages 50 to 60 percent, touching over 90 percent in summer and autumn transition months.

The historical maximum seawater temperature in the Arabian Gulf is reported as 36.2°C, measured at the eastern coast of Saudi Arabia. Recent studies by Al-Banaa & Rakha [1] and Bower [2] have shown that the seawater temperature in the northern Gulf is increasing with a rate higher than the global values. Since 1985, seawater temperature in Kuwait Bay, in the northern Arabian Gulf, has increased on average 0.6°C per decade. This is about three times faster than the global average rate reported by the Intergovernmental Panel on Climate Change. Differences are due to regional and local effects. The increase of seawater temperatures coupled with industrial thermal discharges could have some impacts on the physical and biological environment in the Gulf.

2. GULF SEA COOLING FOR ELECTRICITY AND DESALINATED WATER PRODUCTION

All forms of generating electricity and desalinated water (fossil or nuclear, except hydro-power) require ultimate heat sink (UHS) to cool the excess heat generated during the production. UHS is provided by a large body of water, typically an ocean, big river or lake, where most of the world's power plants are located. In inland states where no such body of water can be found, cooling towers with manmade cooling ponds are built to provide the UHS. In order to minimize the environmental impact to an acceptable level, every state is enforcing temperature effects, among others, from thermal plumes to be typically less than 5°C (as in the UAE) between the intake and effluent water channels. This is considered an acceptable environmental impact for the price of producing electricity and water from desalination.

The Gulf is a shallow sea bordered by several states undergoing rapid economic growth involving substantial construction along the shores and offshore regions, underpinned by its massive oil and gas industry. Changes are so rapid in this region, which includes the construction of power plants and desalination plants on the Gulf shore (oftentimes in tandem) that may impact on temperature and salinity changes in the restricted water flows along the coast. Sheppard, et al. [3], Lattemann & Hoepner [4], and Areiqat & Mohamed [5] examined the biological and ecological impacts on the Gulf's marine life from the thermal plume generated by the power and desalination plants. However, environmental impact studies are generally focused on local ecosystem effects and have difficulty projecting an assessment on the Gulf as a whole with a long term perspective.

Electricity and water generation are administered by the same government authorities in most of the Gulf states, such as Abu Dhabi Water & Electricity Authority (ADWEA), and the plants are all located on the coast using Gulf seawater as the UHS to cool the excess heat generated in the plants. The Gulf is posing a unique situation due to its geographic bathymetry of the sea coupled with unprecedented rapid development along the coastal states in the last couple of decades. It is furthermore important to make a proper assessment on thermal plume effects on the Gulf whenever a large industrial plant is to be added and what could be its long term impact on the Gulf. The combined seawater desalination capacity in the Gulf exceeds 11 million tons of water per day, which is about half of the world's capacity. Saudi Arabia, Kuwait, and UAE have the largest installed desalination capacity in the Gulf. Discharges of heated water into the Gulf are massive from more than 55 desalination plants as well as power stations along the Gulf coast, however their environmental impact of high temperature and salinity are assessed mainly in a local sense, and not on a Gulf-wide basis. (refer to *Figure 2. Map of desalination and power plant facilities in the Arabian Gulf*⁴).

One effective method of mitigating the environmental impact from desalination plants is to co-locate desalination plants together with power plants whenever possible, especially for larger plants. The total intake water volume can be reduced when the cooling effluent water from the power plant serves as feed-water to the desalination plant, which minimizes the impact of entrainment and impingement, the usage of chemicals, and construction and land use impacts. This is why most of the operating desalination plants in the Gulf are cogeneration plants for electricity, run by the same company. To avoid negative effects from high temperature effluent stream, the discharge channel should achieve maximum heat dissipation from the waste stream to the atmosphere before entering the seawater. This may sometimes require cooling towers, and maximum dilution with fresh seawater before discharge. Mixing and dispersal of the discharge plume can be enhanced by

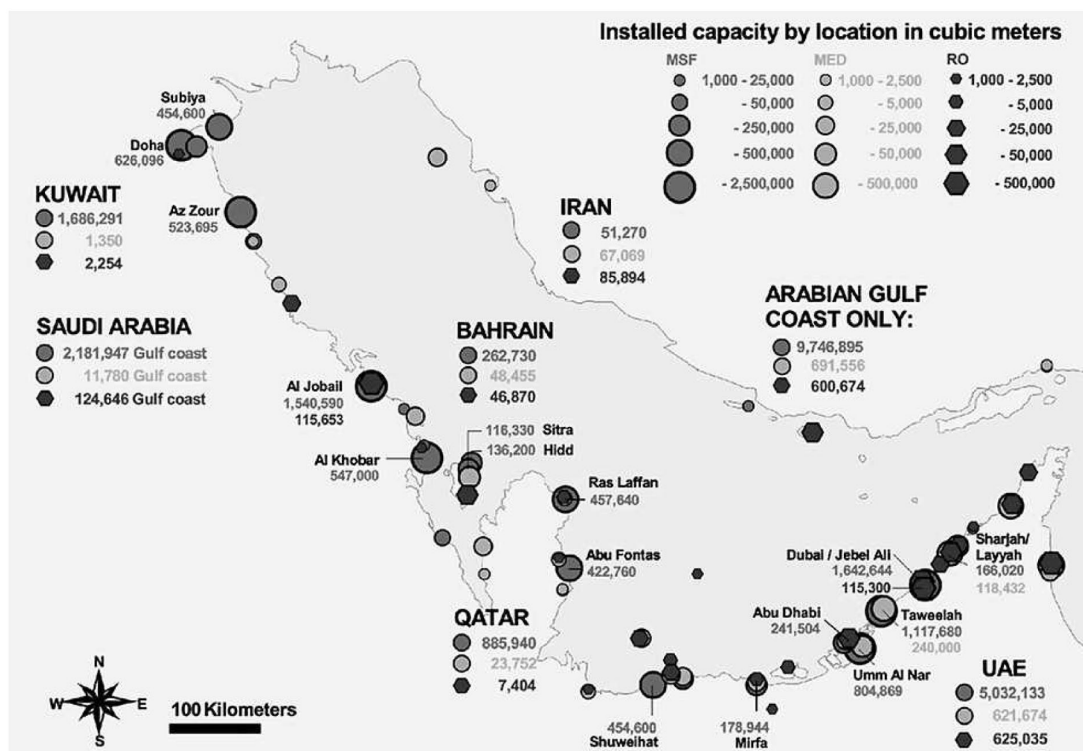

Fig. 2. Map of Desalination and Power Plant Facilities in the Arabian Gulf Showing the Installed Capacities for 3 types of Desalination Plants⁴

installing a diffuser system. To analyze the thermal plume spreading in a specific project site, the environmental and operational conditions are investigated by hydrodynamic modeling, accompanied by in-situ salinity and temperature measurements for density calculations before and during the operation of the plant.

3. INTRODUCTION OF NUCLEAR POWER PLANTS IN THE GULF REGION

Over 400 commercial nuclear power plants (NPP) are in operation today in 31 countries delivering about 15% of the total electricity demands globally. Despite the tragic accident at Fukushima in 2011, rapidly growing economies, primarily in Asia, are continuing with new-build NPPs with additional lessons learned from Fukushima. The United Arab Emirates (UAE) became the most recent nation in July 2012 to formally enter into nuclear power plant construction with the granting of the Construction License to its first NPP at the Barakah site on the southern coast of the Gulf, becoming the first Arab country to construct a nuclear power. When completed in 2020, with four units of 1,400 MWe PWR reactors from Korea, it is expected to deliver about 25% of the nation's electricity. The Bushehr nuclear plant on the northern shore of the Gulf was expected to reach full power in 2012, and became

the first NPP in the Middle East connected to the grid. It is a single unit 1,000 MWe PWR reactor from Russia. Both plants are located at the opposite sides of the Gulf, taking cooling water from the Gulf seawater.

Reasons for seeking nuclear power for the Gulf countries are clear. In his paper at the "Nuclear Energy in the Gulf" conference in 2009, Blix made a convincing argument that it may be economically advantageous for countries rich in oil and gas to use nuclear power to generate the increasing amounts of domestic electricity needed, and export the oil and gas that they would otherwise burn to make electricity and water [6]. A major driving force is the fact that nuclear power can provide huge amounts of energy without emitting CO₂ and contributing to global warming, provided the radiation and nuclear safety, security, and nonproliferation infrastructures are well-placed.

Introduction of NPPs in the Gulf region is a reality in the UAE and Iran, and other Gulf Cooperation Council (GCC) countries are considering their energy options as well as safety concerns of being neighbors to nuclear power countries. NPPs are a proven means of producing electricity, mainly for base load capacity for providing a larger bulk of load demands. A modern fleet of commercial NPPs generate over 1,000 MWe per unit with about 33% thermal efficiency. This means about three times more heat is generated by the reactor, and two-thirds of it has to be dissipated in the UHS. Due to its size capacity, NPPs

bring one of the largest thermal plumes among power plants and desalination plants. It is thus important to understand the environmental impact generated from thermal plumes of NPPs in the Gulf area considering its unique geology and climatology.

Barakah units 1&2 (BNPP) are licensed for construction, taking full advantage of making use of its reference plant Shin-Kori units 3&4 under construction in Korea, which is about three years ahead of construction schedule to Barakah. Both NPPs share the overall safety and design characteristics of the APR1400 Generation III pressurized water reactor (PWR). However, several site-specific design differences had to be addressed including:

- Higher UHS temperature of the Arabian Gulf water
- Higher ambient air temperature
- Effects of dust and sandstorms
- Lower electric grid voltage and frequency

Consideration of the higher UHS temperature of the Gulf sea, in particular, resulted in several design changes to accommodate the site-specific design requirements including:

- The electrical capacity of the emergency diesel generators is increased to accommodate the increased loads resulting from higher seawater and ambient temperatures.
- The number of essential service water pumps designed to be operating during normal shutdown is changed from one pump per division to two pumps per division due to the higher seawater temperature.
- The circulating water system intake and discharge conduits are enlarged to accommodate the higher seawater temperature.

Above considerations were thoroughly reviewed by the Federal Authority for Nuclear Regulation (FANR) before they issued the Construction License to the Emirates Nuclear Energy Corporation (ENEC) in July, 2012 [7].

The UHS provides the source of cooling water and heat sink for the plant essential service water system (ESWS). The ESWS removes heat from the component cooling water system

(CCWS) through the CCW heat exchangers. The water source of the UHS is the Gulf and it is capable of providing sufficient cooling water for at least 30 days to permit plant safe shutdown and subsequent cooling under the worst environmental conditions as specified in the regulatory requirement [8]. Due to the once-through nature of the UHS cooling water and the overall size of the UHS, water evaporation is not a significant controlling parameter to be considered in the UHS design. A typical APR1400 NPP secondary side is designed for 36.5°C (normal condition) and 38.5°C (accident condition) of the UHS temperature of the Gulf. In fact, the plant is designed to be shut down when the UHS temperature exceeds 38.5°C, as specified in the Technical Specification [7].

4. THERMAL-HYDRAULIC PARAMETRIC STUDY OF A SIMPLIFIED PWR SECONDARY SIDE

The thermal efficiency of the steam Rankine cycle is affected mostly by the turbine inlet pressure and outlet pressure, i.e., condenser pressure. With given turbine inlet pressure, the lower the condenser pressure (and temperature) is, the higher the thermal efficiency is. As depicted in *Figure 3. Thermal efficiency of the Rankine cycle*, the thermal efficiency of the system is very sensitive to the turbine exhaust pressure (and temperature) [9]. The lowest pressure (and temperature) of the cycle is limited by the temperature of the cooling water supplied to the condenser. Condensation occurs when the temperature of the condenser cooling water is below the saturation temperature of the steam entering the condenser. In practice, the temperature difference between cooling water and steam is about 10°C to 15°C. For example, if the cooling water is at 20°C, the condenser temperature is about 35°C and corresponding saturation pressure is 0.006 MPa. The corresponding thermal efficiency of the cycle would be 32% (refer to *Figure 3*). If the cooling water is at 35°C, the condenser is at about 50°C and 0.013 MPa. The thermal efficiency of the cycle would be 30%. Increase of cooling seawater temperature by 15°C results in a 2 percentage-point loss of efficiency and about a 6% power loss. This means for a 1450 MWe power cycle in APR1400, as in the cases of the Shin-Kori site in Korea and a Gulf site, the power loss would be about 90 MWe.

To investigate the loss of power and efficiency, a simplified steam Rankine cycle is assumed and analyzed

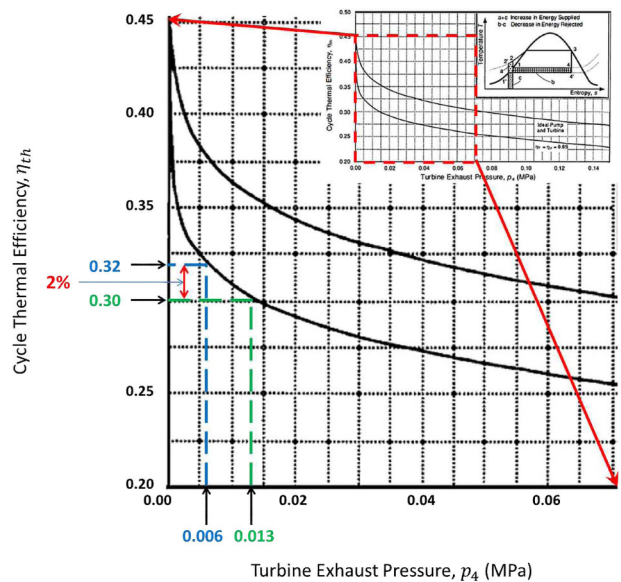

Fig. 3. Thermal Efficiency of Rankine Cycle for a Saturated Turbine Inlet State for Varying Turbine Outlet Pressure. Turbine Inlet: 7.8 MPa Saturated Vapor.⁹

using the HYSYS code from Aspen Tech (Figure 4. Flow diagram of simplified steam cycle). Parameters of the primary and secondary cycle conditions are given in Tables 1 and 2.

As shown in Figure 5. Electric power output for varying seawater temperature, the power output with 20°C of seawater temperature is about 1460MWe and the output is decreased to 1370 MWe as the seawater temperature increases to 35 °C, inverse-linearly proportional to the temperature, resulting in about a 6% power loss. Loss of power by elevated seawater temperature is not limited to nuclear power plants but is true for all types of power plants using a steam cycle with seawater cooling.

Table 1. Primary Cycle Conditions

Thermal power	3983MW
RCP power	17MW
RCP adiabatic Eff.	95%
P1, pressure/temperature	2250psia(15.5MPa) / 323.9°C
P3, pressure/temperature	2330psia(16.1MPa) / 290.6°C

Table 2. Secondary Cycle Conditions

S1, pressure	1000psia(6.9MPa)
S2, pressure, vapor fraction	1000psia(6.9MPa) / 1
Turbine adiabatic Eff.	95%
S4, vapor fraction	0
Seawater in, pressure/volume flow	1atm (101.3kPa) / 3,827,000L/min
Pump, adiabatic Eff.	95%
Condenser, pressure drop	0

5. DESIGN CHANGES ASSOCIATED WITH THE COOLING TEMPERATURE

The circulating water system (CWS) provides cooling seawater for the removal of the waste heat from the condenser and turbine-generator building closed cooling water (TGBCCW) heat exchanger and displaces this heat to the sea as an ultimate heat sink (UHS). UHS temperature of a Gulf NPP is higher than that of Shin-Kori 3&4 in Korea by about 15°C. Due to the elevated UHS temperature, the flow rate of cooling water for a Gulf NPP needs to be increased. The flow rate for Shin-Kori 3&4 is about 65 ton/sec and that of a Gulf NPP is about 100 ton/sec. The temperature difference between inlet and outlet seawater under limiting condition (high temperature) is about 7°C for a Gulf NPP and 11.5°C for Shin-Kori 3&4 [7].

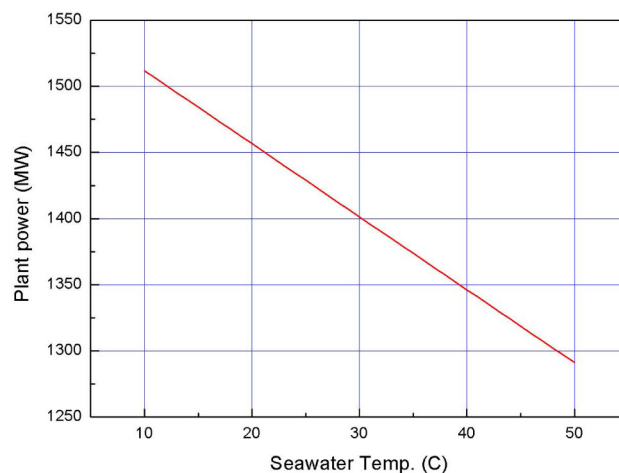

Fig. 5. Electric Power Output for Varying Sea Water Temperature

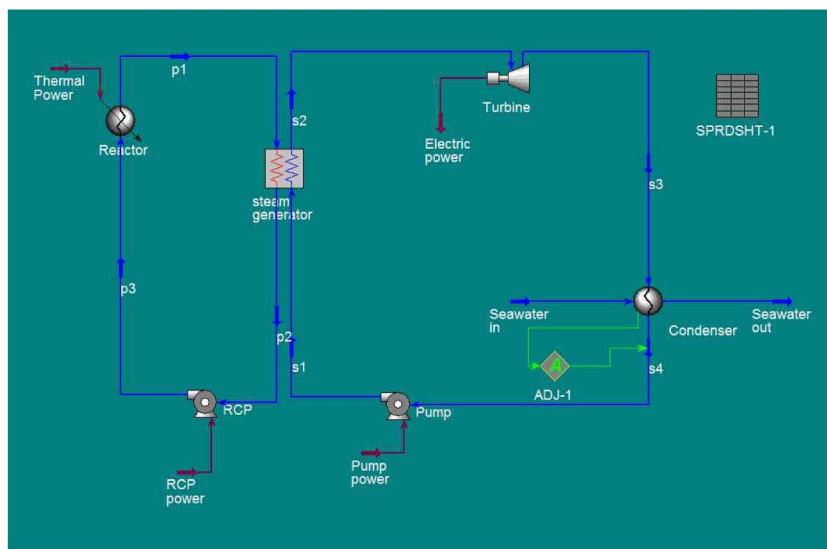

Fig. 4. Flow Diagram of Simplified Steam Cycle (HYSYS)

From the equations given below, the heat transfer area (A) and cooling seawater flow rate (\dot{m}) should be increased with given constant duty of heat transfer (\dot{Q}), specific heat (C_p), heat transfer coefficient (h), and narrow temperature difference between inlet and outlet seawater (ΔT).

$$\dot{Q} = \dot{m}c_p\Delta T \quad (1)$$

$$\dot{Q} = hA\Delta T \quad (2)$$

With given waste heat from the condenser, the main condenser heat transfer area and circulating water flow are increased to accommodate the higher seawater temperature.

In addition to the design modification to accommodate the higher seawater temperature, seawater bypass flow is provided in a Gulf NPP to limit the temperature difference between the intake and discharge of seawater no higher than 5°C as dictated by the local authority. The bypass seawater is not flowing through the condenser, thus bypassing the condenser, and mixes with the outlet seawater flow from the condenser. If an equal amount of bypass seawater is mixed with the seawater from the condenser, the average temperature rise can be reduced by half. The seawater bypass system (not in the reference plant design of Shin-Kori 3&4), which mixes seawater with cooling water being discharged from the plant, is designed to reduce the thermal environmental effects on the Arabian Gulf in the immediate area of the plant for environmental protection, and is not nuclear safety related.

In addition to the seawater bypass system, the Safety Evaluation Report issued in July 2012 states the additional design changes and regulatory body's evaluation. "The electrical capacity of the emergency diesel generators is increased from 8,000 kW to 8,700 kW to accommodate the increased loads resulting from higher seawater and ambient temperatures at the site. Similarly, the electrical capacity of the AC diesel generator is increased from 7,200 kW to 8,700 kW. These design changes are a result of Gulf site-specific characteristics. Heating, ventilation and air-conditioning systems (HVAC) of the component cooling water heat exchanger building, essential service water intake structure, and circulating water intake structure systems include the addition of air handling units, because open air-cooling is not practical at a Gulf site. Similarly, air handling units are added to the plant electrical and I&C rooms. These design changes are a result of Gulf site-specific characteristics." [7]

6. ASSESSMENT OF OPERATIONAL SAFETY MARGINS AND IMPACT ON THE SEAWATER ENVIRONMENT

The average seawater temperature at a Gulf site is presumed to be higher than that of the Korean reference site by about 15°C. The elevated temperature results in a difference in the cooling systems: the essential service

water system, circulating water system, and component cooling water system. In general, the size of the heat exchangers and capacity of the pump have been increased with respect to Shin-Kori 3&4. Accordingly, the gap between seawater temperature and its high temperature limit for normal operation is narrower at a Gulf site than at Shin-Kori 3&4. If it reaches the seawater temperature limit of 38.5°C for the maximum accident conditions, the reactor may need to be shut down for safety concerns. It is conceivable that a Gulf NPP could have unplanned outages due to the extreme hot water temperature over 38.5°C as the Technical Specification requirement. However, the transient of the seawater temperature is slow and at least predictable based on the measurements of the previous several days.

Above analysis shows how the impact of high sea temperature can affect the single (or dual) unit NPP plant's efficiency, and additional cooling water capacity could be engineered for design changes to meet the thermal discharge limitations. Impact on the marine eco-system is limited to local areas in the immediate vicinity of the NPP site, provided the temperature increase of discharge water is less than 5°C. When more than a single (or dual) unit is to be built at the same site, as is typically done in nuclear stations (such as two-dual 4-units at Shin-Kori, two-dual 4-units at Barakah), the volume of intake water to discharge has to be increased accordingly. The discharge water channel should be sufficiently isolated from the intake water channel to prevent any inadvertent mixing. More detailed analysis on the thermal plume effect is necessary in securing operational flexibility under extreme temperature conditions as well as to assess the environmental impact.

Any significant increase of the total Gulf water temperature by introducing multiple nuclear power plants on the Gulf shore is not physically reasonable compared to ever present solar radiation. The surface area of the Gulf is about 239,000 km² and the average depth is about 36 m; the volume is about 9x10¹² m³. Considering that the average insolation (annual solar radiation) is about 2,000 kWh/m²-y (~ 228 W/m²), the incoming radiation energy is about 57 TW on the Gulf (refer to *Figure 6. Solar radiation on Middle East & Africa*). Assuming the reflectivity (albedo) of the Gulf as 1/3, about 38 TW is absorbed by the sea. On the other hand, the waste heat from nuclear power plants is about 2.7GW_{th} for a 4 GW_{th} plant and thus it is less than 1/10,000 of the solar radiation absorbed. Then the temperature increase by a nuclear power plant is less than 5x10⁻⁸°C, assuming there is complete mixing within the Gulf and no exchange of water between the Gulf of Oman and the Arabian Gulf. From the above simple calculations, a thermal plume from multiple NPPs is not a global problem in the Gulf, i.e. it has a negligible effect on the increase of global average temperature. But there would be local problems around the site including damage to the local marine biosphere and thermal recirculation.

However, when a new NPP site is sought in the Gulf

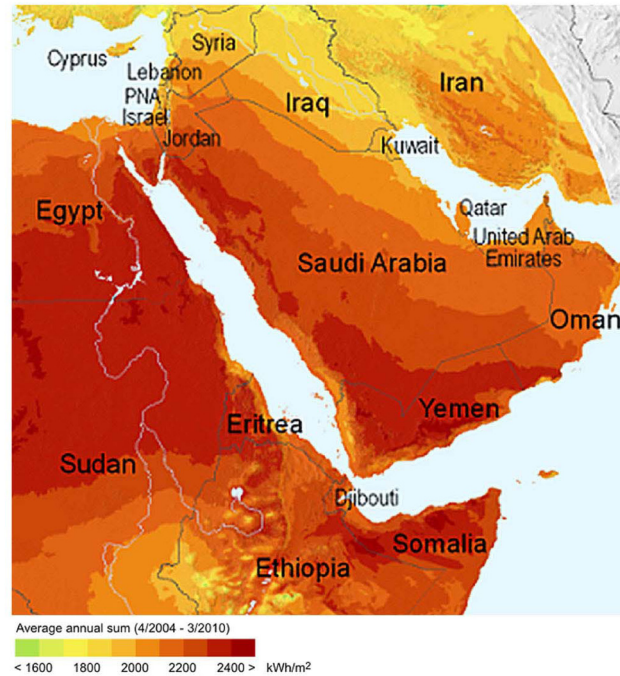

Fig. 6. Solar Radiation on Middle East and Africa. Average Annual Sum for the Arabian Gulf Sea Surface Area is Assumed to be ~ 2000 kWh/m² [SolarGIS.info]

area for future expansions, it may be prudent to consider more favorable candidate sites to overcome seawater cooling limitations as shown along the Arabian Gulf side. Economic gains of generating more MWe of electricity from improved thermal efficiency and possible savings from reducing additional water/electric/ventilation systems need to be evaluated in detail. The Gulf of Oman or the Red Sea coastal areas have 100 to over 1,000 meter-deep bathymetry with lower water temperatures. The recent opening of the cross-national oil pipeline between Abu Dhabi and Fujairah made direct access to the Indian Ocean possible. Detailed analyses of candidate sites would be required to assure that acceptable sites to meet a number of critical criteria, an important one being the favorable thermo-aquatic conditions of the coastal sea.

7. CONCLUSIONS

Based on the brief study of unique seawater conditions of the Arabian Gulf, where a number of NPPs are being built, the following conclusions are made:

- i. The Arabian Gulf sea is one of the most thermally stressed bodies of water on earth due to its high temperature geo-climatic conditions coupled with a high density of large-scale industrial plants including fossil powered desalination plants producing water and electricity. Discharge water temperature increase is controlled to less than 5°C in all power

plants when seawater is used as the ultimate heat sink in the Gulf region.

- ii. New NPPs being introduced to the Gulf will bring a similar thermal effect to the sea on a larger scale. However, the thermal discharge from NPP's into the Gulf is negligible compared to the natural solar radiation absorbed, thus the thermal impact is limited to local seawater adjacent to the NPP site.
- iii. The average seawater cooling temperature difference of 15°C higher will result theoretically in about a 2% drop of thermal efficiency in a simplified Rankine cycle of a PWR plant, equivalent to approximately a 90 MWe loss in a typical APR1400 power plant.
- iv. A number of engineered design changes are incorporated into the Gulf NPP secondary/tertiary side to provide additional heat transfer surface areas in the heat exchangers. They include an increased capacity of the condenser circulating water system, bypass seawater to discharge water, and associated electrical, and HVAC systems. Operational safety can be assured with Technical Specification limitations when the seawater temperature exceeds 38.5°C.
- v. More site-specific detail thermal plume analysis is needed for multi-units on the same site to assure sufficient separation of the intake to discharge waters, together with operational limitations from the seawater temperature. Thermo-aquatically more favorable conditions could be considered via alternate

sites for higher plant efficiency, such as the Fujairah coast on the Arabian Peninsula, when new nuclear sites are investigated under the future nuclear energy expansion plan.

(This paper was prepared in support of the Gulf Nuclear Energy Infrastructure Institute program at Khalifa University and the joint research between Khalifa University and KAIST.)

REFERENCES

- [1] K. Al-Banaa and K. Rakha, "Seasonal Variability of Temperature Measurements in a Shallow Bay", *Journal of Coastal Research*, SI56, pp. 782-786, 2009.
- [2] Amy Bower, Heather Hunt, and James Price, "Character and dynamics of the Red Sea and Persian Gulf outflows", *Journal of Geophysical Research*, v.105, pp 6387-6414, 2000.
- [3] Charles Sheppard, et al., "The Gulf: A young sea in decline", *Marine Pollution Bulletin*, v. 60, pp. 13-38, 2010.
- [4] Sabine Lattemann and Thomas Hoepner, "Environmental impact and impact assessment of sea water desalination", *Desalination*, v.220, pp.1-15, 2008.
- [5] Ahmed Areiqat and Khaled Mohamed, "Optimization of the negative impact of power and desalination plants on the ecosystem", *Desalination*, v.185, pp.95-103, 2005.
- [6] Hans Blix, "Nuclear Energy in the Gulf", *Nuclear Energy in the Gulf Conference*, ECSSR, Abu Dhabi, 2009.
- [7] FANR, *Safety Evaluation Report of an Application for a License to Construct Barakah Units 1&2*, FANR, Abu Dhabi, July 2012.
- [8] USNRC, "Regulatory Guide 1.27: Ultimate Heat Sink for Nuclear Power Plants", Rev. 2, 1976.
- [9] Neil. E. Todreas and Mujid. S. Kazimi, *Nuclear Systems I*, Taylor & Francis, 1993.