

Available online at www.sciencedirect.com**ScienceDirect**

Energy Procedia 61 (2014) 2123 – 2126

Energy

ProcediaThe 6th International Conference on Applied Energy – ICAE2014

A Framework for Self-healing Smart Grid with Incorporation of Multi-Agents

Shiwei Xia*, Xiao Luo, Ka Wing Chan

The Hong Kong Polytechnic University, Hung Hom, Kowloon, Hong Kong SAR, P.R. China

Abstract

A hierarchical framework incorporated with multi-agents is proposed for enabling the self-healing of smart grid. While the central control agent in the upper layer adopts the multiple-step Taylor series function (MTSF) method to efficiently predict the system stability using wide area measurement system (WAMS) data, agents with shared information in the lower layer protect the devices in plug-in micro grids more effectively and adaptively compared with traditional protection. The proposed framework shows the self-healing capability for ensuring the security of smart grid by reliably preventing faults and flexibly coordinating generations. Simulation results of modified WSCC 3-generator system with plug-in micro grids have confirmed the validity of the proposed framework.

Keywords: Smart Grid; Self-healing; Multiple-step Taylor Series Function; Multi-Agents

1. Introduction

It is arduous to guarantee system security with robust network alone for power system with increasing deregulated power market and distributed generations (DGs). Power system operators urgently need more powerful and effective strategies to analyze and control system security. The self-healing smart grid is a prospective direction for this purpose. Its main difference from traditional power grids is the capability for fault self-prevention and self-repairing. Smart grids with intelligent functions could achieve self-healing efficiently and reliably, thus will be more adaptive and secure than ever before [1-2].

A hierarchical framework incorporated with multi-agents is proposed for self-healing smart grid. Considering the increasing utilization of wide area measurement system (WAMS) in power industries, the agents in the upper layer adopted the multiple-step Taylor series function (MTSF) method to efficiently predict the system stability based on WAMS data, and to plan the control scheme for micro grids. The agents in lower layer would effectively detect and remove faults based on the shared information to avoid the deterioration of system security.

2. Power system stability prediction by MTSF method based on WAMS data

Security analysis is one of the major concerns in developing functionalities associated with self-healing smart grid [3]. WAMS data containing essential information of power system operating status provides opportunities to monitor system dynamic behaviours on-line in both spatial and temporal

* Corresponding author. Tel.: +852-27665392; *E-mail address:* s.w.xia@connect.polyu.hk.

dimensions. Thus, to develop an efficient numerical tool based on WAMS data for security analysis is promising. A MTSF method using low order derivatives is applied to predict power system stability [4].

$$y_{n+1} = \sum_{j=0}^s h^j \sum_{i=0}^k \alpha_{ij} y_{n-i}^{(j)} \quad (1)$$

where h stands for the predicting step; s is the order of derivatives; α_{ij} is the coefficient; k is the number of previous points and y are state variables. MTSF method predicts generator angles based on low order derivatives of previous k -step which are obtained by cubic spline interpolations of WAMS data.

3. Proposed framework for self-healing smart grid

3.1. Proposed Hierarchical framework with MAs

Power system is evolving towards smart grid with well-planned plug-in micro grid of various renewable energy such as wind farms, solar generations and battery energy storage systems (BESS) etc. As one branch of artificial intelligence, multi-agents system (MAS) is readily to applied in this distributed system. A hierarchical framework for Smart Grid incorporated with MAs is present in Fig.1.

The central control agent in upper layer formulates the overall control scheme for the whole system as the brain of micro grids, while each micro grid connects to transmission network by switch on/off agents in a plug-in and play manner. In upper layer, WAMS data are transferred on the data exchange highway to the central control agent for stability predicting; then the central control agent forecasts the stability by MTSF method and sends back control schemes to micro grids. In each micro grid, the coordination agent refines the control scheme for each physical device. Physical devices also have protection agents (such as device protection agent 1 and device protection agent 2 etc.) with capabilities of detecting faults by monitoring agents and removing faults by adjusting agents. The network configuration agents broadcast the changed status of corresponding physical device to micro grid interface, which will send changed network topologies to the central control agent for system stability predicting. The coordination of MAs in micro grids is described in the following sub-section.

3.2. Local protection and coordination by MAs

Traditional protection consists of overlapped protection zones with time coordination, where ‘off-line setting, real-time acting’ relays responded independently according to procedural arrangements without extra real-time adjustment. They have two demerits: 1) it is not easy to reset the threshold or protection zones for the on-line operation of power system. With deregulated power market and distributed generations, topologies of power system would change frequently, which makes traditional protection not suitable anymore; 2) if primary protection fails, the backup protection needs a long time to cut off the fault which will deteriorate the system security due to the coordinated time.

The proposed protection with MAs enables the self-healing grid by reliably preventing faults and adaptively adjusting protection parameters to ensure system security. In Fig.1, the monitoring agent reports physical devices status to device protection agents. With shared information among device protection agents, the fault can be easily located (e.g. by adding currents of two ends of single line or plus the total currents of a closed plane based on Kirchhoff’s Current Law); then the device protection agent commands the adjusting agent to remove the fault. In the meantime, the monitoring agent checks the status of physical device periodically. There are two possibilities. 1) The fault is isolated successfully. The monitoring agent sends back the changed status to device protection agents, which will notify the reconfiguration agent to update the topology database and the coordination agent to reset protection zones and parameters accordingly. 2) If the adjusting agent fails to remove the fault, the adjusting agent of adjacent physical device as backup protection will be notified immediately to cut off the fault based on the shared information. The delay time for the backup protection with MAs is shorter than traditional protection with time coordination between primary and backup protections; therefore, the former will lighten the destruction resulting from the longer persistence of fault.

With communication capabilities of MAs, the coordination agent could also adjust generations in micro grids to enhance the system security. Additionally, it is easy to modify the protection zones or threshold to avoid the possible malfunction due to improper off-line fixed parameters in traditional protection. Thus, the proposed scheme with MAs would improve the adaptability of power grid.

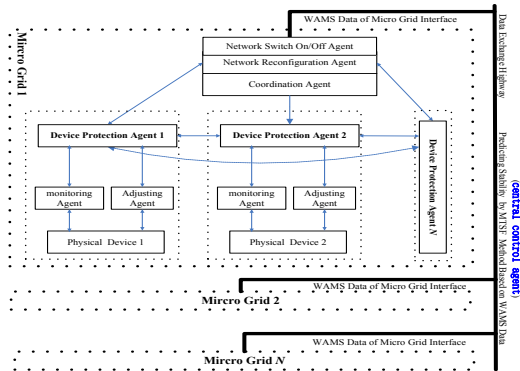

Fig. 1 Proposed framework for Smart Grid

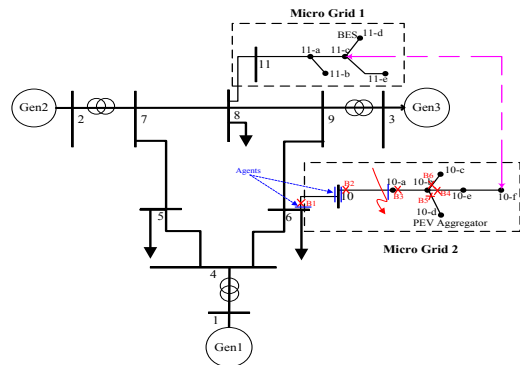

Fig. 2 WSCC system with micro grids

4. Case studies

A modified WSCC 3-generator 9-bus system with two micro grids is tested. The micro grid 1 and 2 include one BESS at bus 11-d and one plug-in electric vehicle (PEV) aggregator at bus 10-d, respectively. They are controllable loads with a range as [-5MW, 5 MW] for BES and [-3MW, 3MW] for PEV aggregator. The voltage upper and lower limits are in the range of [0.95, 1.1] pu. In the normal operating condition, the connection of two micro grids, line 11c-10f, is switch off. Each device has been deployed with properly agents as partially indicated as blue stubs in Fig. 2. The agent-oriented and completely distributed Java Agent Development (JADE) framework [5] is adopted to create agents, and WAMS data is obtained from time domain simulations with small steps.

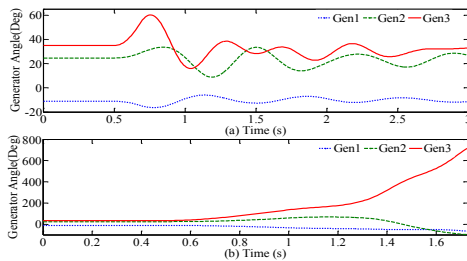

Fig. 3 Stability of WSCC with micro grids

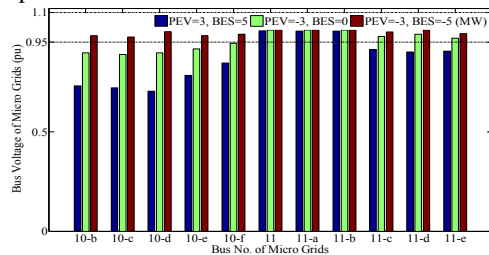

Fig. 4 Voltage profiles of WSCC with micro grids

Suppose a three phase fault occurs at line 10-10a at 0.5s. As the device protection agents of line 10-10a share the information on the result of the currents summation, they finds it was non-zero, which indicates a fault occurring at line 10-10a. This fault location is broadcasted to all device protection agents in micro grid 2, and the command to isolate the fault is sent to adjusting agents of line 10-10a. The system is predicted to be stable when the fault is removed by opening breaker 2 after 0.18s (including circuit breaker opening time (5 cycles) and relay overtravel time [6]). Otherwise the primary protection fails, the monitoring agents at line 10-10a check their status periodically and report this ongoing fault to the device protection agent of line 10-10a. The latter requests the nearest device protection agent of line 6-10 to remove the fault by opening breaker 1 (B1 in Fig.1). The time delay is only one checking cycle of monitoring agents and the system is stable as in Fig.3 (a). While for traditional overcurrent protection relay, the time delay is the coordination time between the primary and backup protections, which is usually 0.3s to 0.4s [6]. Fig.3 (b) shows the system is unstable even for the optimistic time interval as 0.3s

for traditional backup protection. It is obvious that the traditional protection deteriorates the system security, while the proposed framework with MAs provides much more effective protections to system.

When the system settles down after a short transient period, micro grid 2 requires the transmission system to resupply its power if possible. The central control agent looks up the network topology database and explores an alternative power path for micro grid 2, i.e. the line 11c-10f. Therefore, the central control agent commands the two micro grids to link through line 11c-10f. The adjusting agents of line 11c-10f switch on the corresponding breakers to connect the two micro grids while breaker 3 switches off to island the fault. Now micro grid 2 regains power supply and monitoring agents reports the network topology to the reconfiguration agent. However, due to a long power restoration path, nodal voltages of micro grid 2 are very low somewhere as shown in Fig.4 for the pre-fault condition that PEV aggregator and BES charged power at full rate, i.e. PEV=3MW and BES=5MW. Thus, the coordination agents in micro grid 1 and micro grid 2 negotiate to improve the voltage profile. Considering the local generation is much more effective than the distant one to support voltages, a simple coordination is assumed in a descending priority as follows. 1) The controllable load in micro grid 2, namely PEV aggregator at bus 10-b, acts as power generation at full discharging rate to support voltage profile firstly, while BES only stops consuming power, i.e. PEV=-3MW and BES=0MW; 2) if voltages are not satisfied, the BES in Micro 1 fully discharges as another power generation to further boost nodal voltages, i.e. PEV=-3MW and BES=-5MW; 3) if voltage are still not satisfied, part of loads would be shed off besides scheme 2). As the nodal voltages of two micro grids shown in Fig.4, the voltages are satisfied when both PEV and BES play as power generations, namely when scheme 2) is applied. The proposed scheme ensures the system security by flexibly coordinating generations in a very simple way. As for a complicated large system, the coordination can be refined by well-developed optimal power flow method.

As network is reconfigured, the protection zones should be changed. After the coordination agent in micro grid 2 checks the network topology, it assigns B4 and B5 as backup protections for B6, instead of B3 as the backup protection for B4, B5 and B6 in the pre-fault condition. Based on the easily modified scheme, the proposed framework with MAs can reliably and adaptively protect power system.

5. Conclusion

A two-layer framework with multi-agents is proposed for developing a self-healing smart grid. The upper layer predicts system stability by the MTSF method based on WAMS data, while the lower layer with multi-agents protects system by effective fault-prevention and proper generation coordination. The proposed framework is capable to efficiently predict system stability and reliably prevent fault development as well as flexibly coordinate generations to ensure system security, and would form the future power grid with self-healing ability. The on-going work would focus on the application of this framework to a large practical power system equipped with WAMS devices with consideration of loss of communication among multi-agents.

References

- [1] Wang J, Conejo AJ, Wang C, Yan J. Smart grids, renewable energy integration, and climate change mitigation-Future electric energy systems. *Appl Energy* 2012; 96: 1-3.
- [2] Amin SM, Giacomoni AM. Smart Grid, Safe Grid. *IEEE Power and Energy Magazine* 2012; 10(1): 33-40.
- [3] Zhang P, Li F, Bhatt N. Next-Generation Monitoring, Analysis, and Control for the Future Smart Control Center. *IEEE Trans Smart Grid* 2010; 1(2): 186-92.
- [4] Xu Y, Bai X, Guo Z. Transient Stability Calculation Based on Explicit Multi-step Multi-derivative Integration Method. *Automation of Electric Power Systems* 2009; 33(15): 33-7.
- [5] F. Bellifemine, G. Caire, and D. Greenwood, *Developing Multi-Agent Systems with JADE*. Chichester, U.K.: Wiley, 2007.
- [6] Recommended Practice for Protection and Coordination of Industrial and Commercial Power Systems. *IEEE Std 242*, 1986.

Biography

Shiwei Xia received the MSc degrees in Electrical Engineering and Automation from Harbin Institute of Technology. He is currently pursuing the Ph.D. degree in Hong Kong Polytechnic University. His research area is smart grid with renewable energy.