

Available online at [www.sciencedirect.com](http://www.sciencedirect.com)**ScienceDirect**

Procedia CIRP 52 (2016) 216 – 221

[www.elsevier.com/locate/procedia](http://www.elsevier.com/locate/procedia)

Changeable, Agile, Reconfigurable &amp; Virtual Production

## Knowledge capture in CMM inspection planning: barriers and challenges

D. Anagnostakis<sup>a,\*</sup>, J. Ritchie<sup>a</sup>, T. Lim<sup>a</sup>, A. Sivanathan<sup>a</sup>, R. Dewar<sup>b</sup>, R. Sung<sup>b</sup>, F. Bosché<sup>a</sup>, L. Carozza<sup>a</sup><sup>a</sup>*Heriot-Watt University, Riccarton, Edinburgh, EH14 4AS, United Kingdom*<sup>b</sup>*Renishaw Plc., Research Park North, Riccarton, Edinburgh, EH14 4AP, United Kingdom*\* Corresponding author. Tel.: +44 0 131 449 5111. E-mail address: [dal78@hw.ac.uk](mailto:dal78@hw.ac.uk)

### Abstract

Coordinate Measuring Machines (CMM) have been widely used as a means of evaluating product quality and controlling quality manufacturing processes. Many techniques have been developed to facilitate the generation of CMM measurement plans. However, there are major gaps in the understanding of planning such strategies. This significant lack of explicitly available knowledge on how experts prepare plans and carry out measurements slows down the planning process, leading to the repetitive reinvention of new plans while preventing the automation or even semi-automation of the process. The objectives of this paper are twofold: (i) to provide a review of the existing inspection planning systems and discuss the barriers and challenges, especially from the aspect of knowledge capture and formalization; and (ii) to propose and demonstrate a novel digital engineering mixed reality paradigm which has the potential to facilitate the rapid capture of implicit inspection knowledge and explicitly represent this in a formalized way. An outline and the results of the development of an early stage prototype - which will form the foundation of a more complex system to address the aforementioned technological challenges identified in the literature survey - will be given.

© 2016 Published by Elsevier B.V. This is an open access article under the CC BY-NC-ND license

[\(http://creativecommons.org/licenses/by-nc-nd/4.0/\)](http://creativecommons.org/licenses/by-nc-nd/4.0/).

Peer-review under responsibility of the scientific committee of the Changeable, Agile, Reconfigurable &amp; Virtual Production Conference 2016

**Keywords:** : Computer aided inspection planning; Measurement strategies; CMM; Knowledge capture; Knowledge formalisation

### 1. Introduction

Towards Industry 4.0 and “Smart Factory”, measuring and inspection technologies play a key role as a control tool in manufacturing. Coordinate Measuring Machines (CMM) are widely used tools not only for assessing product quality and conformance with regard to original design intent, but also for providing feedback upstream. In the last three decades, many computer-aided inspection planning (CAIP) tools were developed for planning CMM measurements. However, there are still open questions in understanding how a strategy is generated. Although significant work has been conducted to propose practices and guidance, the lack of explicitly formalized knowledge on how experts produce a plan constitutes a bottleneck in product life cycle management, leading to the repetitive generation of new inspection plans. CMM inspection planning is a time consuming task, even for experienced people and the lack of appropriate knowledge

formalization tools obstructs the digitization and automation of the task, causing loss of this expertise.

In this paper an overview of existing inspection planning systems is provided discussing the barriers and challenges with regard to knowledge capture and formalization. Also knowledge elicitation and representation tools in engineering tasks such as design, machining and assembly planning are discussed. Methodological barriers in inspection planning are then identified. An early stage digital tool is proposed demonstrating the potential for capturing, digitizing and formalizing implicit knowledge in planning a CMM measurement. The outline and preliminary results of a trial are provided to form the foundation of a more advanced system.

### 2. Computer aided inspection planning systems

A review [1] of some early CAIP systems developed up to 1994 is presented. In [2] inspection planning for free-form

surfaces the methods are classified in contact and non-contact inspection. In the latest study [3] of the related state of the art CAIP systems were categorized in: a) tolerance and b) geometry driven. The current survey is focused on tactile inspection via an identified taxonomy around the technology employed: i) Expert systems: Knowledge based systems (KB), Neural Networks (NN), Genetic Algorithms (GA), Hybrid-fuzzy expert systems, ii) Virtual Environments, iii) Other advanced systems.

### 2.1. Expert systems

Expert systems are tools capable of utilising domain specific knowledge embedded in different forms (rules, knowledge bases, etc.) to solve a problem requiring heavy computational load. In the domain of Computer Aided Inspection Planning a wide range of such systems has integrated artificial intelligence to support CMM inspection planning.

#### 2.1.1. Knowledge based systems

ElMaraghy et al. [4] developed one of the first KB inspection planning systems providing the novelty of features clustering and sequencing depending on related datums. Feature recognition is carried out for manual and machine inspection, accessibility analysis, selection of probe and probing points using separate knowledge bases for each step as proposed by Chan and Gu [5]. The system does not provide any representation of the final inspection sequence while alternative part orientations are not considered. A similar system is suggested by Gu [6] for features clustering in groups accessible by the same probe angle. Another tool [7] generates measurement points and path by selecting critical features for inspection using the Process Capability indexes approach. The system in [8] classifies features into categories associated with geometric and dimensional tolerances using dedicated knowledge bases.

#### 2.1.2. Neural Networks

The NN-system [9] for CMM path planning for multi-component inspection has a learning ability for new strategies (path generation, sampling and components orientation for an optimised path). Zhang et al [10] developed a system to calculate the sample size for measuring hole-features considering the size, dimensional and geometrical tolerances and machining processes undertaken. Heuristic NN [11] were used to provide a near optimal solution using the Hopfield approach consisting of smaller networks to decrease the complexity of the algorithm. Hwang et al [12] proposed a tool to minimise part and probe re-orientations, optimise inspection path and generate CMM part programs directly for prismatic parts.

#### 2.1.3. Genetic Algorithms

A GA was proposed by Lu et al [13] to address the problem of multi-component inspection planning. The system was built using a relationship matrix and the genetic operators: encoding, heuristic population initialization, fitness evaluation, crossover and mutation. Form errors in basic

geometries of a workpiece are detected by the proposed algorithm [14]. The data acquired can be stored in a KB system to provide optimised sampling strategies. The system designed by Kovacic and Brezocnik [15], considers part geometry, probing configuration and measuring machine attributes as well as the possible interactions between the probe and the part. Drawbacks are the slow search of optimal solution due to the complexity of the formulated problem and the manual selection of measurement points.

#### 2.1.4. Hybrid-fuzzy systems

This hybrid fuzzy-KB system illustrated in [16] generates inspection plans. An inference mechanism with rules and functions calculates the sample size from past data, points distribution is estimated by a Hammersley sequence while non-feasible points are repositioned. Beg and Shunmugam [17] suggested an Object Oriented Planner for Inspection of Prismatic Parts (OOPIPP) structured via fuzzy logic based modules for feature recognition, part orientation, number and distribution of inspection points, accessibility analysis, sequencing of probe orientations and faces to inspect. The feature-based inspection planning in [18] uses a feature precedence tree and associated probe approach directions. Hussien et al. [19], proposed an automatic system incorporating modules for feature recognition, sampling, accessibility analysis and clustering. The probing system is modelled as an infinite line.

### 2.2. Virtual environments

A virtual CMM was developed [20] for training novice operators. The measurement path is generated by a module which optimizes the route taking into account points defined by a user. The inspection paths generated are represented only with a list of measuring points. Wang et al [21] built a virtual CMM where user hand motions are recognized by a gesture vision system to control the CMM; the system being designed for training CMM operators. Hu et al [22] developed a virtual CMM where a user plans a measurement strategy, performs measurements and evaluates the results without using a real machine. A haptic device was employed by Yang and Chen [23] for a realistic representation of CMM operation. The user plans an inspection moving a hand held stylus over a 3D CAD model. The proposed method can also be applied for training purposes but doesn't provide any output instructions for reuse or the generation of new formalized plans.

### 2.3. Other advanced systems

A CAD-directed system was proposed [24] for extracting functional and tolerancing information from a CAD model and using a heuristic algorithm, the planner searches for efficient inspection sequences for polyhedral parts with rectangular and cylindrical features having only dimensional tolerances in the format of linear chains. A CAD-integrated planning system [25] was designed for developing paths with minimum points. Substitute routes are added when collisions are detected. The CATIP system [26] designs optimal plans by minimising probe changes and reorientations and features

clustering. A CAD-based CAIP tool [27] creates alternative plans using weighted parameter values for each probing point while when collisions are detected sub-paths are added using heuristic rules. Other systems [28], [29] provide inspection planning tools integrated with process planning. A series of software packages are also available throughout the market, mainly enabling just offline and online programming of a CMM (Table 1).

**Table 1, Commercial CAIP software systems**

CAIP/CMM programming Software	
Calypso (Zeiss) [30]	CMM Manager (Nikon) [33]
PC-Dmis (Hexagon) [31]	NX CMM (Siemens) [34]
Modus (Renishaw) [32]	PAS CMM (PAS Technology) [35]

### 3. Knowledge capture and formalization

Knowledge capture is the process of extracting knowledge and expertise from human experts [36]. Acquisition and formalisation of implicit human knowledge is a complex and highly time consuming task causing a bottleneck in product lifecycle management [37]. Hence knowledge capture has become a major research topic within knowledge engineering aiming to develop methods and tools that facilitate easy and quick knowledge extraction from an expert [38]. In the next paragraphs a range of techniques to capture expert knowledge in different manufacturing tasks is presented.

#### 3.1. Knowledge capture in inspection planning

Inspection planning knowledge was extracted and modelled using MOKA modelling language [39] as a tool to structure an informal IDEF0-ontology knowledge representation for the development of a KB system. Sources of the knowledge obtained are from interviews with expert CMM programmers and documentation (review reports, handbooks and manuals). Such elicitation techniques are greatly time-consuming [40] while the subject-experts may not express their thoughts and decision making effectively [41]. Barreiro et al [42] applied an extension of MOKA methodology to elicit inspection planning knowledge only from documents. This technique is extended further to other related studies [43]. Decision rules for optimal CMM sampling [44] were developed using a data mining tool PCPACK [45] to extract knowledge from documents. Additionally, ontologies may be structured, for building a KB intelligent inspection planning system [46].

#### 3.2. Knowledge capture in engineering tasks

Traditional knowledge capture techniques include interviewing an expert, observation, task interruption and questioning, answering structured questionnaires, sound and video recording while performing a task [47]; however, these are slow and not usually very effective [48]. Therefore, it is necessary to develop unobtrusive techniques which do not interrupt the expert-subject and facilitate easy formalisation independent from associated overheads. In the literature many techniques have been developed to facilitate human expertise

and knowledge capture in other domains [49].

#### 3.2.1. Knowledge capture in design

Engineering design is a critical stage in the product life cycle and an area that has attracted much attention. The DAKA tool [50] was built for design activity and knowledge capture through mining and monitoring CAD events. Rea et al [51] recommended a customised interface for automated capturing of design knowledge and decision making. The output is recorded in XML language and post-processed for analysis. A tool [52] described for design rationale capture, may help engineers to structure the design thinking process, support in decision making and extract design rationale. Liu et al [53] combined a biometric system for capturing knowledge and psychological data in order to extract expertise in the design process. This novelty associates engineer's cognitive affective status with conventional decision making. A novel knowledge capture system [54] was presented for unobtrusive user logging while operating in a CAD environment. The output structured in XML language informs the automatic generation of multiple representations. Novelties introduced include English-syntax instructions and annotated video captures. VADER [55] is a synchronised multi-modal data capture tool for engineering design reviews enabling knowledge acquisition by logging different input types such as: 3D visualisation, audio, video and other devices; a similar CAD application is given in [56].

#### 3.2.2. Knowledge capture in other engineering tasks

Other engineering activities that have been of interest in the aspect of knowledge capture and formalisation are process planning and assembly. A haptics system [57] proposed for capturing expertise in planning machining operations allows real-time simulation of drilling, turning and milling processes. A novel system [58] was designed for assembly process planning using an octree decomposition method of a CAD model. The Virtual Assembly Rapid Prototyping (VARP) system [59] is a tool for analysis of assembly activities in an immersive environment; knowledge is extracted in the form of a chronocyclegraph which is further processed to identify specific activities and generate new assembly plans.

### 4. Research gaps in current literature

In the above sections a wide range of different fields of engineering was covered (Figure 1) so as significant research barriers are recognised.

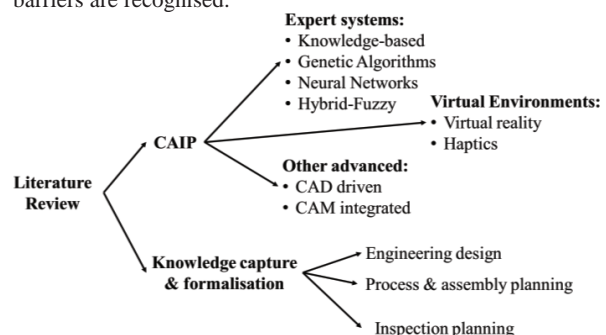

**Fig. 1, Research fields of interest under review**

In the CAIP systems reviewed and specifically in expert systems, the proposed tools involve knowledge captured and structured in different forms such as rules, knowledge bases and heuristic algorithms; however, it is not explicitly explained what are the sources or how the knowledge has been captured to be embedded within CAIP systems. Although the virtual environment systems mentioned could be used as tools for knowledge elicitation [60] they have been used solely for digital CMM representation and operation modelling. The techniques presented in Section 3.1 are mainly manual, time consuming [48] and not effective as the experts involved are distracted from the process [61] or may not express their experience and knowledge effectively [47]. Also, the knowledge extracted from documents or handbooks lacks human rationale, reasoning and expertise. Thus, two major barriers are identified:

- (i) absence of a capture tool for CMM inspection planning implicit knowledge;
- (ii) lack of a methodology for formalising human expertise and rationale in inspection planning.

The following research questions and respective challenges are resulting from the barriers recognised:

- How can implicit knowledge and rationale in inspection planning be captured rapidly?
- How can implicit expertise and rationale captured be represented in a formalised way?

To address these challenges, proper tools and techniques are required which could include approaches applied in other engineering tasks as previously presented in Section 3.2.

**5. Proposed methodology**

An effective and rapid way to capture human expert knowledge is to track and log user’s activity while performing a task. In inspection planning this can be achieved by tracking the probe’s path while it is moved around a workpiece by a human while performing the measurements. Implicit knowledge resides within the logged user activities and probe’s motion paths. Post task, it is necessary to analyse the logged data and represent the knowledge captured in easily understandable and reusable formats such as a points trajectory around the component [60].

In this current work the main goal is to digitalise a physical world task and investigate how such a tool can be used for unobtrusive capturing of inspection planning knowledge and rationale. By tracking probe’s motion, human expertise and knowledge implied in inspection planning tasks can be represented and documented effectively. Multiple representations can be produced for different purposes such as process mapping, training and generation of new inspection plans. Figure 2 presents an outline of the proposed methodology.

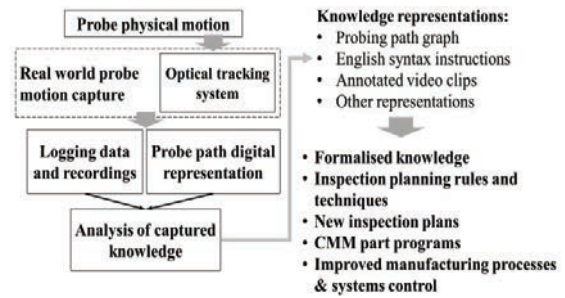

Fig. 2, Outline of the proposed methodology

*5.1. Early stage prototype*

Based on this an early inspection planning knowledge capture and formalisation prototype has been developed and tested on a simple geometry workpiece (Figure 3). The system consists of optical infrared cameras to track the probe’s motion path. A stylus with retro-reflective markers along the length was used as a probe. The software operating the tracking cameras exports logged data of each marker’s position in 3D.

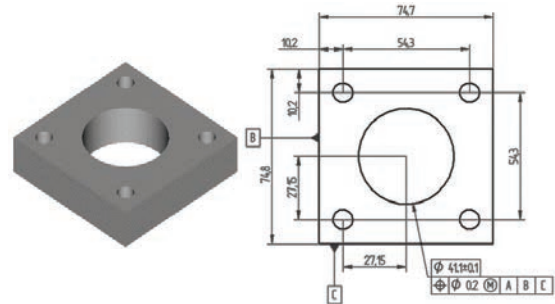

Fig. 3, Test part and drawing with tolerancing information

The probe’s motion path is generated by processing these data. Figures 4, 5 and Table 2 show some preliminary results from the pilot study structured in different representations.

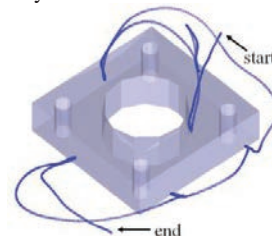
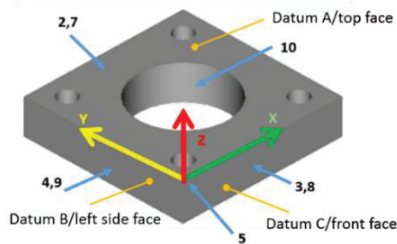

Fig. 4, Probe motion chronocyclegraph

Table 2, Logged user activities in English syntax instructions

Time (sec)	Inspection planning step	Description
0.00	Part location setup	User locates part on table on selected orientation
3.00	Part orientation	User selects zero point of local/part coordinate system (0,0,18.5)
6.25	Part alignment	User is starting probing top face to define Z-plane of part CS
7.70		User is probing first point (40.15426, 8.92922, 21.79893)





1. **Probing features used for part CS**
2. Probing top face at 3 points
3. Probing front face at 2 points
4. Probing left side face at 1 point
5. **Part alignment/Construction of part CS**
6. **Probing datum features for central hole's true position evaluation**
7. Probing datum feature A (top face) with 9 points
8. Probing datum feature C (front face) with 6 points
9. Probing datum feature B (left side face) with 6 points
10. **Probing feature central hole as a cylinder with 8 points**

**Fig. 5.** Extracted sequence of activities

The different knowledge representations allow the study of measurement strategies so that knowledge captured can be formalised and used as a foundation for the development of standard methodologies in CMM inspection planning.

### 5.2. Future development

In future work, the aim is to automate the proposed methodology by implementing a digital tracking tool using a Mixed Reality system [62]. The system under development consists of an RGB-D camera integrated with a head mounted display (HMD). Figure 6 shows the view from the HMD screens. Using such an approach a fast digital representation of the physical world can be generated where the integration with tools for unobtrusive knowledge capture and representation will be feasible.



**Fig. 6.** User's point of view (left eye) through HMD

## 6. Conclusion

A wide range of tools and techniques for computer aided inspection planning were reviewed and classified into categories depending on the technology used. In addition, existing knowledge elicitation techniques in inspection planning were discussed proving the need for a tool and methodology to support implicit knowledge capture and explicit formalization in inspection planning as a future challenge. To fill the research gaps identified, a methodology and an early stage prototype were presented along with preliminary results aiming to form the framework for a more advanced system in the future.

Using the tool proposed, implicit knowledge in CMM inspection planning can be captured, digitised and represented to facilitate the understanding of CMM part programming

techniques. Having this knowledge captured, inspection planning and measurement strategies can be analysed and investigated so that patterns of activities, decision making and associated rationale are identified contributing to the formalization of CMM part programming techniques.

This can potentially lead to more effective inspection plans, tailored Computer-Aided-Inspection environments to fit CMM programmers' needs and improve training methods to facilitate further the generation of high quality measurement strategies and CMM part programs. Consequently, the potential benefits are multiple in a smart manufacturing environment, as the level of process control quality can be significantly increased by receiving more accurate feedback from the inspection process and informing manufacturing stages upstream.

## References

- [1] ElMaraghy, H., & ElMaraghy, W. (1994). Computer-aided inspection planning (CAIP). *Manufacturing Research and Technology*, 20, 363-363. <http://dx.doi.org/10.1016/B978-0-444-81600-9.50021-3>.
- [2] Li, Y., & Gu, P. (2004). Free-form surface inspection techniques state of the art review. *CAD Computer Aided Design*, 36(13), 1395-1417. <http://doi.org/10.1016/j.cad.2004.02.009>
- [3] Zhao, F., Xu, X., & Xie, S. Q. (2009). Computer-Aided Inspection Planning - The state of the art. *Computers in Industry*, 60(7), 453-466. <http://doi.org/10.1016/j.compind.2009.02.002>
- [4] ElMaraghy, H., Gu, P., Bollinger, J. G. (1987). Expert Inspection Planning System. *CIRP-Annals Manuf. Technology*, 36(1), 85-89.
- [5] Chan, K., & Gu, P. (1993). An object-oriented knowledge-based inspection planner. *Proceedings of IEEE Pacific Rim Conference on Communications Computers and Signal Processing*, 2, 646-649. <http://doi.org/10.1109/PACRIM.1993.407278>
- [6] Gu, P. (1994). A knowledge-based inspection process planning system for coordinate measuring machines. *Journal of Intelligent Manufacturing*, 5(5), 351-363. <http://doi.org/10.1007/BF00127652>
- [7] Abbasi, G. Y., Ketan, H. S., & Adil, M. B. (2005). Integrating design and production planning with knowledge-based inspection planning system. *Arabian Journal for Science and Engineering*, 30(2), 245-262.
- [8] Pei, S. H., & Ma, Y. M. (2012). The Expert System for Auto Programming in Coordinate Measuring Machines. *Applied Mechanics and Materials*, 120, pp. 254-257.
- [9] Lu, C. G., Morton, D., Myler, P., & Wu, M. H. (1995). An artificial intelligent (AI) inspection path management for multiple tasks measurement on co-ordinate measuring machine (CMM): an application of neural network technology. *Global Engineering Management: Emerging Trends in the Asia Pacific*, Proceedings of 1995 IEEE Annual Int. Conference, 353-357. <http://doi.org/10.1109/IEMC.1995.524608>
- [10] Zhang, Y., Nee, a. Y. C., Fuh, J. Y. H., Neo, K., & Loy, H. (1996). A neural network approach to determining optimal inspection sampling size for CMM. *Computer Integrated Manufacturing Systems*, 9(3), 161-169. [http://doi.org/10.1016/S0951-5240\(96\)00005-5](http://doi.org/10.1016/S0951-5240(96)00005-5)
- [11] Wu, Y., Liu, S., & Zhang, G. (2000). An Artificial Intelligent Measuring Sequence Path Planning for CMM. *College of Precision Instruments and Opto-Electronics Engineering*, Tianjin University, P.R. China
- [12] Hwang, C. Y., Tsai, C. Y., & Chang, C. a. (2004). Efficient inspection planning for coordinate measuring machines. *The International Journal of Advanced Manufacturing Technology*, 23(9-10), 732-742. <http://doi.org/10.1007/s00170-003-1642-x>
- [13] Lu, C. G., Morton, D., Wu, M. H., & Myler, P. (1999). Genetic algorithm modelling and solution of inspection path planning on a coordinate measuring machine (CMM). *International Journal of Advanced Manufacturing Technology*, 15(6), 409-416. <http://doi.org/10.1007/s001700050084>
- [14] Killmaier, T., & Babu, a. R. (2003). Genetic approach for automatic detection of form deviations of geometrical features for effective measurement strategy. *Precision Engineering*, 27(4), 370-381. [http://doi.org/10.1016/S0141-6359\(03\)00043-6](http://doi.org/10.1016/S0141-6359(03)00043-6)

- [15] Kovacic, M., & Brezocnik, M. (2003). Genetic algorithm method for computer aided quality control, Proceedings of the 3rd Research Expert Conference with International Participation, Quality, 125–130
- [16] Hwang, I., Lee, H., & Ha, S. (2002). Hybrid neuro-fuzzy approach to the generation of measuring points for knowledge-based inspection planning. *International Journal of Production Research*, 40(11), 2507–2520.
- [17] Beg, J., & Shunmugam, M. S. (2002). An object oriented planner for inspection of prismatic parts-OOPIPP. *International Journal of Advanced Manufacturing Technology*, 19(12), 905–916.
- [18] Cho, M. W., Lee, H., Yoon, G. S., & Choi, J. (2005). A feature-based inspection planning system for coordinate measuring machines. *International Journal of Advanced Manufacturing Technology*, 26(9-10), 1078–1087. <http://doi.org/10.1007/s00170-004-2077-8>
- [19] Hussien, H. A., Youssef, A. M., & Shoukry, M. K. (2012). Automated Inspection Planning system for CMMs, Proceedings of 2012 IEEE International Conference in Engineering and Technology (ICET), 1-6
- [20] Zhao, L. (2012). Development of a VR-based CMM system for industry training and CMM path planning (MSc thesis, University of Manitoba).
- [21] Wang, Y., Guo, X., Sun, K., & Chen, Y. (2012, July). Study on virtual coordinate measuring machine based on augmented virtuality. In VECIMS, 2012 IEEE International Conference on (pp. 97-102).
- [22] Hu, Y., Yang, Q., & Sun, X. (2012). Design, Implementation and Testing of Advanced Virtual Coordinate-Measuring Machines. *IEEE Transactions on Instrumentation & Measurement*, 61(5), 1368. doi:10.1109/TIM.2011.2175828.
- [23] Yang, Z., & Chen, Y. (2005). Inspection path generation in haptic virtual CMM. *Computer-Aided Design and Applications*, 2, 273–282.
- [24] Roy, U., Xu, Y., & Wang, L. (1994). Development of an intelligent inspection planning system in an object oriented programming environment. *Computer Integrated Manufacturing Systems*, 7(4), 240–246. [http://doi.org/10.1016/0951-5240\(94\)90013-2](http://doi.org/10.1016/0951-5240(94)90013-2)
- [25] Fan, K. C., & Leu, M. C. (1998). Intelligent planning of CAD-directed inspection for coordinate measuring machines. *Computer Integrated Manufacturing Systems*, 11(1-2), 43–51.
- [26] Limaïem, A. (1999). CATIP: a computer-aided tactile inspection planning system. *International Journal of Production Research*, 37(2), 447-465. <http://doi.org/10.1080/002075499191869>
- [27] Dong, Y., Liu, D., Zhao, H., Wang, W., Wu, J. (2011). CAD model-based intelligent inspection planning for coordinate measuring machines, *Chinese Journal of Mechanical Engineering (English Edition)*, 24 (4), 567-583, DOI:10.3901/CJME.2011.04.567
- [28] Khan, A. A., Nasr, E. A., Al-ahmari, A., Abdulhameed, O., & Abidi, M. H. (2014). An Integrated CAPP-CAFD-CAIP System for Prismatic Parts. In *Proceed. Of IIE Annual Conference*, Institute of Industrial Engineers.
- [29] Polini, W., & Moroni, G. (2015). A frame for a computer aided inspection planning system. *Int. J. Engineering & Technology*, 4(1), 125–138. <http://doi.org/10.14419/ijet.v4i1.3937>
- [30] <http://www.zeiss.com>
- [31] <http://hexagonmi.com/products/software/pc-dmis>
- [32] <http://www.renishaw.com/en/modus--10495>
- [33] <https://www.cmmmanager.com/>
- [34] <https://www.plm.automation.siemens.com/>
- [35] <http://www.pastechnology.com/>
- [36] Kendal, S., Creen, M. (2007). *An introduction to knowledge engineering*, 1-25, Springer London.
- [37] Hayes-Roth, F., Waterman, D., & Lenat, D. (1984). *Building expert systems*, Addison-Wesley, Reading, MA.
- [38] Shadbolt, N., & O'Hara, K. (1997). *Model-based expert systems and the explanation of expertise. Expertise in context* (pp. 315-337). MIT Press.
- [39] Martinez, S.; Barreiro, J.; Cuesta, E. & Alvarez, B. (2009). Moka Ontology Variant to Apply to the Inspection Planning Process in a KBE System. 1471-1473, Proceedings of the 20th International DAAAM Symposium, ISBN 978-3-901509-70-4, ISSN 1726-9679, pp 736.
- [40] T. Gavrilova, T. Andreeva, (2012), "Knowledge elicitation techniques in a knowledge management context", *Journal of Knowledge Management*, Vol. 16 Iss 4 pp. 523 - 537
- [41] Ambrosini, V. and Bowman, C. (2001), "Tacit Knowledge: Some Suggestions for Operationalization", *Journal of Management Studies*, Vol. 38, No. 6, pp. 811-829.
- [42] Barreiro, J., Martínez Pellitero, S., Cuesta González, E., Álvarez Álvarez, B. J., & Fernández Álvarez, P. (2009). High level diagrams for identification of knowledge as a basis for a KBE implementation of inspection planning process.
- [43] Martínez-Pellitero, S., Barreiro, J., Cuesta, E., & Raya, F. (2015). Categorization of Inspection Elements in Coordinates Measurement for a KBE Implementation. *Procedia Engineering*, 132, 1037-1044.
- [44] Alvarez, B., Cuesta, E., Martinez, S., Barreiro, J., & Fernandez, P. (2010). Implementation of decision rules for CMM sampling in a KBE system. In Proceedings of the 36th Int. MATADOR Conference.
- [45] PCPACK, Software Package, Version 1.4.6R, Nottingham, UK, 2008.
- [46] Stojadinovic, S., & Majstorovic, V. (2014). Developing engineering ontology for domain coordinate metrology. *FME Transaction*, 42(3), 249–255. <http://doi.org/10.5937/fmet1403249s>
- [47] Burge, J. E. (2001). Knowledge elicitation tool classification. Artificial Intelligence Research Group, Worcester Polytechnic Institute.
- [48] Lockwood, K., 2009. "Using Analogy to Model Spatial Language Use and Multimodal Knowledge Capture", Ph.D. dissertation, Northwestern University, Illinois.
- [49] Ritchie, J. M., Sung, R. C. W., Rea, H., Lim, T., Corney, J. R., & Howley, I. (2008). The use of non-intrusive user logging to capture engineering rationale, knowledge and intent during the product life cycle. In PICMET 2008.
- [50] Jin, Y., & Ishino, Y. (2006). DAKA: design activity knowledge acquisition through data-mining, *International Journal of Production Research*, 44(14), 2813-2837, DOI:10.1080/00207540600654533
- [51] Rea, H. J., Ritchie, J. M., & Corney, J. R. (2007). Automating Digital Capture of Engineering Knowledge. 4th International CIRP-Sponsored Conference (DET2007) (pp. 19-21).
- [52] Bracewell, R., Wallace, K., Moss, M., & Knott, D. (2009). Capturing design rationale. *CAD Computer Aided Design*, 41(3), 173–186. <http://doi.org/10.1016/j.cad.2008.10.005>
- [53] Liu, Y., Sung, R. C. W., Lim, T., & Ritchie, J. M. (2011). Affective Knowledge Capture System for Computer-Aided Design Environment
- [54] Sung, R., Ritchie, J. M., Rea, H. J., & Corney, J. (2011). Automated design knowledge capture and representation in single-user CAD environments, *Engineering Design*, 22:7, 487-503,
- [55] Sung, R. C. W., Ritchie, J. M., Lim, T., Sivanathan, A., & Chantler, M. J. (2013). The evaluation of a virtual-aided design engineering review (VADER) system for automated knowledge capture and reuse. Proceedings of ASME-DET Conf. (Vol. 2 B, Computers and Information in Engineering Division). <http://doi.org/10.1115/DETC2013-12030>
- [56] Sivanathan, A., Lim, T., Ritchie, J., Sung, R., Kosmadoudi, Z., & Liu, Y. (2013). The application of ubiquitous multimodal synchronous data capture in CAD. *CAD Computer Aided Design*, 59, 176–191. <http://doi.org/10.1016/j.cad.2013.10.001>
- [57] Fletcher, C., Ritchie, J., Lim, T., & Sung, R. (2013). The development of an integrated haptic VR machining environment for the automatic generation of process plans. *Computers in Industry*, 64(8), 1045–1060. <http://doi.org/10.1016/j.compind.2013.07.005>
- [58] H. Medellin, J. Corney, J. M. Ritchie, T. L. (2008). Automatic Generation of Robot and Manual Assembly Plans Using Octrees. *Assembly Automation*, 22, 1753–1759. <http://doi.org/10.1016/j.buildenv.2006.10.027>
- [59] Lim, T., Medellin, H., Sung, R., Ritchie, J., & Corney, J. (2009). Virtual Bloxing – Assembly Rapid Prototyping of Near Net Shapes. *Ingeniería Mecánica*, 3(2), 151–156. <http://doi.org/10.1115/WINVR2009-723>
- [60] Sung, R. C., Ritchie, J. M., Robinson, G., & Day, P. (2010, January). Automated Design Knowledge Capture Using Virtual Reality. In ASME 2010 World Conference on Innovative Virtual Reality (pp. 195-202). American Society of Mechanical Engineers.
- [61] Kornfein, M., & Rajiv, V. (2012). Capturing Engineering Process Knowledge. *Knowledge Generation Communication & Management*. Orlando, FL.
- [62] Carozza, L., Bosche, F. N., & Abdel-Wahab, M. S. (2015). An immersive hybrid reality system for construction training. In: Proceedings of the 15th CONVR 15, October 5-7, 2015, Banff-Alberta, Canada. (pp. 1-10)