

## Report

# Identification, by Homozygosity Mapping, of a Novel Locus for Autosomal Recessive Congenital Ichthyosis on Chromosome 17p, and Evidence for Further Genetic Heterogeneity

Alice Krebsová,<sup>1,2</sup> Wolfgang Küster,<sup>3</sup> Gilles G. Lestringant,<sup>4</sup> Bernt Schulze,<sup>6</sup> Britta Hinz,<sup>1</sup> Philippe M. Frossard,<sup>5</sup> André Reis,<sup>1,7</sup> and Hans Christian Hennies<sup>1</sup>

<sup>1</sup>Department of Molecular Genetics and Gene Mapping Center, Max Delbrück Center for Molecular Medicine, and <sup>2</sup>Institute of Human Genetics, Charité, Humboldt University Berlin, Berlin; <sup>3</sup>TOMESA Clinics, Bad Salzschlirf, Germany; <sup>4</sup>Department of Dermatology, Tawam Hospital, and <sup>5</sup>Department of Pathology, Faculty of Medicine and Health Sciences, Al Ain, United Arab Emirates; <sup>6</sup>Praxis für Humangenetik, Hannover, Germany; and <sup>7</sup>Institute of Human Genetics, Friedrich Alexander University Erlangen, Nürnberg, Germany

Autosomal recessive congenital ichthyosis (ARCI) comprises a group of severe disorders of keratinization, characterized by variable erythema and skin scaling. It is known for its high degree of genetic and clinical heterogeneity. Mutations in the gene for keratinocyte transglutaminase (*TGM1*) on chromosome 14q11 were shown in patients with ARCI, and a second locus was described, on chromosome 2q, in families from northern Africa. Three other loci for ARCI, on chromosomes 3p and 19p, were identified recently. We have embarked on a whole-genome scan for further loci for ARCI in four families from Germany, Turkey, and the United Arab Emirates. A novel ARCI locus was identified on chromosome 17p, between the markers at D17S938 and D17S1856, with a maximum LOD score of 3.38, at maximum recombination fraction 0.00, at D17S945, under heterogeneity. This locus is linked to the disease in the Turkish family and in the German family. Extensive genealogical studies revealed that the parents of the German patients with ARCI were eighth cousins. By homozygosity mapping, the localization of the gene could then be refined to the 8.4-cM interval between D17S938 and D17S1879. It could be shown, however, that ARCI in the two Arab families is linked neither to the new locus on chromosome 17p nor to one of the five loci known previously. Our findings give evidence of further genetic heterogeneity that is not linked to distinctive phenotypes.

Congenital ichthyosis is a clinically and genetically heterogeneous group of disorders of keratinization (Traupe 1989). Autosomal recessive congenital ichthyosis (ARCI [MIM accession numbers 242100 and 242300]) is a severe condition with an estimated prevalence of 1 per 200,000 newborns. At birth, the condition is often associated with an embedment in a collodion-like membrane, known by the term “collodion baby” (Traupe 1989; Sandler and Hashimoto 1998). Skin scales later develop, covering the entire body surface, including the flexural folds, and characterized by high

variability in size and color. ARCI is usually associated with erythema, which is sometimes mild and almost invisible.

In approximately one-third of ARCI cases, mutations in the gene for transglutaminase 1 (*TGM1*) on chromosome 14q11 underlie the phenotype (Huber et al. 1995a; Parmentier et al. 1995; Russell et al. 1995). Transglutaminase 1 is a Ca<sup>2+</sup>-dependent, mostly membrane-bound enzyme present in keratinocytes. It covalently cross-links proteins by catalyzing the formation of isopeptide bonds between glutamine and lysine residues (Peterson et al. 1983; Kubilus and Baden 1984; Lorand and Conrad 1984; Aeschlimann and Paulsson 1994). Inactivation of transglutaminase 1 in ARCI patients with *TGM1* mutations could be demonstrated by in situ enzyme essays (Hennies et al. 1998b; Hohl et al. 1998; Raghunath et al. 1998). A clear correlation, however, between the clinical picture of ARCI and the mutations identified in *TGM1* is difficult to derive (Hennies

Received March 27, 2001; accepted for publication May 14, 2001; electronically published June 7, 2001.

Address for correspondence and reprints: Dr. Hans Christian Hennies, Department of Molecular Genetics and Gene Mapping Center, Max-Delbrück-Centrum, Robert-Rössle-Str. 10, 13125 Berlin, Germany. E-mail: hennies@mdc-berlin.de

© 2001 by The American Society of Human Genetics. All rights reserved. 0002-9297/2001/6901-0023\$02.00



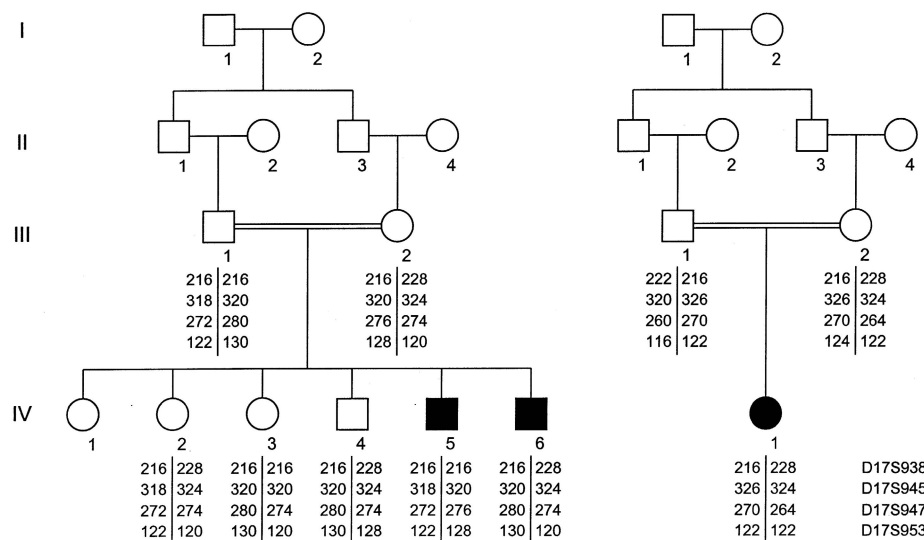

**Figure 2** Pedigrees of the two families from the United Arab Emirates, and construction of haplotypes. *Left*, Family 1. *Right*, Family 2. The parents of the patients are first cousins in both families. Obligatory recombination events in family 1 and lack of homozygosity by descent clearly exclude linkage to the region of the ARCI gene on chromosome 17p.

the anterior and lower aspects of the thighs. Knees and elbows were covered with small, rectangular, dark brown and black thick plaques, disposed along horizontal lines, and the upper back with larger flat plaques grossly disposed on vertical streaks. The rest of the body skin presented with diffuse, superficial scaling that was rather marked in the great folds. The face was spared, except for mild scaling on the ears, the rear of the cheeks, and the scalp. Palmoplantar keratoderma was thick, with deep cracks on the soles and hyperlinearity on the palms, evoking the pattern of a spider web. There was no transgression of the keratoderma. The younger affected brother (IV-6) was also born as a collodion baby. He showed generalized erythroderma and palmoplantar keratoderma. His ichthyosis, however, was always less pronounced than his brother's. Ichthyosis also increased with age, involving mostly the extensor surfaces of the limbs and the upper back, but remained mild, with a tendency to erythroderma, and spared the face.

In the affected girl of the second Emirati family (fig. 2; IV-1), skin scaling on the limbs, the trunk, and the neck were noted at 3 mo of age. Lesions increased with age. At the age of 13 years, ichthyosis consisted of thick, dark brown or black adhering scales. They were often rectangular in shape and disposed along horizontal lines, especially on the upper limbs and the posterior aspect of the lower limbs, including antecubital and popliteal fossae; the dorsa of the hands and the front part of the ankles; and the abdominal wall, flanks, armpits, and nipples. They were larger and polygonal on the extensor aspects of the lower limbs and on the dorsa of the feet, toes, and fingers. Knees and elbows were covered with

thick, diffuse, scaly, black hyperkeratosis. Scaling was very mild on the back and the upper chest and spared the face and neck. In addition, there was a diffuse, waxy, non-transgrediens palmoplantar keratoderma.

DNA of the probands was extracted from blood samples drawn after informed consent. A whole-genome scan for further ARCI loci was performed in the four families, with 380 microsatellite markers from the Génethon final linkage map (Dib et al. 1996), with an average distance of 11 cM. Markers were amplified in singleplex reactions in a final reaction volume of 10  $\mu$ l containing 10 mM Tris, 1.5 mM MgCl<sub>2</sub>, 100  $\mu$ M each dNTP, 0.4 U DNA polymerase (Invitex), 7.0 pmol of each primer, and 20 ng of genomic DNA. One of the primers was end-labeled with fluorescent dye. DNA amplification was performed in PTC-225 thermal cyclers (MJ Research). Products were then pooled and electrophoresed on ABI PRISM 377 automated DNA sequencers (Applied Biosystems).

Data were analyzed using computer programs Genescan v3.0 and Genotyper v2.5 (Applied Biosystems). Two-point LOD score calculations were performed with the computer program package LINKAGE v5.2 (Lathrop and Lalouel 1984; Rockefeller University Statistical Genetics), using an autosomal recessive model with full penetrance. Most-likely haplotypes were constructed either manually or with CRI-MAP v2.41 option Chrompic (Lander and Green 1987). Two-point and multipoint LOD scores under heterogeneity were calculated with the program HOMOG (Ott 1991; Rockefeller University Statistical Genetics) in the software package ANALYZE (Columbia University Genome Center). The pro-

**Table 1**

**Two-Point LOD Scores at Various Recombination Fractions for Markers on Chromosome 17p in Four Families with ARCI**

| FAMILY<br>AND MARKER <sup>a</sup> | TWO-POINT LOD SCORE AT $\theta =$ |        |        |        |        |       |       |       |       |
|-----------------------------------|-----------------------------------|--------|--------|--------|--------|-------|-------|-------|-------|
|                                   | .000                              | .001   | .010   | .050   | .100   | .150  | .200  | .300  | .400  |
| Turkish family:                   |                                   |        |        |        |        |       |       |       |       |
| <i>D17S938</i>                    | -2.560                            | -1.819 | -.888  | -.198  | .049   | .140  | .164  | .122  | .050  |
| D17S1353                          | 2.417                             | 2.412  | 2.367  | 2.160  | 1.893  | 1.616 | 1.334 | .779  | .308  |
| D17S1844                          | 2.157                             | 2.152  | 2.105  | 1.894  | 1.626  | 1.357 | 1.090 | .596  | .221  |
| D17S1791                          | 2.264                             | 2.259  | 2.215  | 2.013  | 1.752  | 1.484 | 1.213 | .688  | .263  |
| <i>D17S945</i>                    | 2.455                             | 2.450  | 2.404  | 2.197  | 1.928  | 1.650 | 1.365 | .802  | .320  |
| D17S1879                          | 2.117                             | 2.112  | 2.067  | 1.865  | 1.605  | 1.337 | 1.066 | .549  | .164  |
| D17S1875                          | 1.787                             | 1.782  | 1.739  | 1.541  | 1.289  | 1.035 | .783  | .337  | .067  |
| <i>D17S947</i>                    | 2.468                             | 2.463  | 2.418  | 2.210  | 1.941  | 1.662 | 1.377 | .812  | .326  |
| D17S1856                          | 1.977                             | 1.972  | 1.926  | 1.723  | 1.468  | 1.213 | .963  | .513  | .186  |
| <i>D17S953</i>                    | −∞                                | -1.028 | -.061  | .484   | .590   | .567  | .494  | .293  | .108  |
| German family:                    |                                   |        |        |        |        |       |       |       |       |
| <i>D17S938</i>                    | −∞                                | -1.867 | -.905  | -.350  | -.180  | -.100 | -.053 | -.010 | -.001 |
| D17S1353                          | 1.188                             | 1.183  | 1.136  | .957   | .784   | .647  | .527  | .299  | .094  |
| D17S1844                          | 2.057                             | 2.050  | 1.991  | 1.751  | 1.494  | 1.264 | 1.043 | .597  | .188  |
| D17S1791                          | 2.001                             | 1.995  | 1.941  | 1.721  | 1.480  | 1.258 | 1.040 | .597  | .188  |
| <i>D17S945</i>                    | 2.120                             | 2.113  | 2.049  | 1.788  | 1.512  | 1.272 | 1.046 | .597  | .188  |
| D17S1879                          | 1.774                             | 1.771  | 1.745  | 1.615  | 1.435  | 1.240 | 1.034 | .596  | .188  |
| D17S1875                          | .871                              | .870   | .859   | .801   | .715   | .619  | .516  | .298  | .094  |
| <i>D17S947</i>                    | 1.774                             | 1.771  | 1.745  | 1.615  | 1.435  | 1.240 | 1.034 | .596  | .188  |
| D17S1856                          | −∞                                | -1.228 | -.251  | .337   | .486   | .500  | .456  | .287  | .093  |
| <i>D17S953</i>                    | −∞                                | -1.968 | -.996  | -.403  | -.204  | -.109 | -.057 | -.011 | -.001 |
| Emirati family 1:                 |                                   |        |        |        |        |       |       |       |       |
| <i>D17S938</i>                    | −∞                                | -1.912 | -.929  | -.308  | -.104  | -.022 | .012  | .024  | .015  |
| <i>D17S945</i>                    | −∞                                | -6.702 | -3.738 | -1.758 | -1.002 | -.620 | -.390 | -.142 | -.033 |
| <i>D17S947</i>                    | −∞                                | -6.905 | -4.004 | -1.993 | -1.190 | -.764 | -.495 | -.185 | -.042 |
| <i>D17S953</i>                    | −∞                                | -7.204 | -4.286 | -2.212 | -1.349 | -.878 | -.574 | -.218 | -.050 |
| Emirati family 2:                 |                                   |        |        |        |        |       |       |       |       |
| <i>D17S938</i>                    | -3.182                            | -1.956 | -.996  | -.371  | -.160  | -.070 | -.028 | -.002 | .000  |
| <i>D17S945</i>                    | -3.266                            | -1.924 | -.959  | -.338  | -.131  | -.047 | -.010 | .007  | .002  |
| <i>D17S947</i>                    | -3.268                            | -1.923 | -.958  | -.337  | -.130  | -.046 | -.010 | .007  | .002  |
| <i>D17S953</i>                    | .728                              | .725   | .705   | .613   | .504   | .402  | .310  | .164  | .066  |

<sup>a</sup> Marker loci analyzed in all families are in boldface italic type.

gram HOMOGM (Bhat et al. 1999; Rockefeller University Statistical Genetics) was used to analyze the genetic heterogeneity for independent disease loci. Genetic maps and further marker data were obtained from the Génethon final linkage map (Dib et al. 1996). The search for candidate genes was performed by comparative analysis of human expressed sequence tag (EST) sequence data from the National Center for Biotechnology Information (NCBI) Human Gene Map (Deloukas et al. 1998), with the NCBI UniGene and SAGE collections, using the program BLAST.

After excluding linkage to the known ARCI loci, we got a first hint at linkage in the genomewide scan with the marker at D17S945, on chromosome 17p, giving a maximum combined LOD score ( $Z_{\max}$ ) of 2.32 at maximum recombination fraction ( $\theta_{\max}$ ) 0.12, under genetic homogeneity. Refined mapping around D17S945 (Genome Database), however, revealed that patients from both consanguineous Emirati families were heterozygous at each marker locus analyzed. Therefore, we assumed

that ARCI in these two families was not linked to the region on chromosome 17p, and we calculated LOD scores for each family separately (table 1). Linkage was thus assessed in all four families with the computer program HOMOG, allowing for heterogeneity. A maximum two-point LOD score of 3.38 at D17S945, with  $\theta_{\max} = 0.00$  and  $\alpha_{\max} = 0.50$ , and a maximum three-point LOD score of 3.65 with data at D17S945 and D17S947 were then obtained. In the Turkish family, a large homozygous interval 29 cM in length was identified between D17S938 and D17S953 (fig. 1A). The construction of likely haplotypes identified the key recombination events in the German family in probands XI-4 at D17S938 and XI-2 at D17S1856 (fig. 1B). Seven in-between markers completely cosegregated with the phenotype. Within this interval, a region was identified as homozygous in all four patients. Exhaustive searches for the family history then revealed that there were actually common ancestors who had married each other in 1679, as documented by the parish register. According

to these records, the parents of the patients were eighth cousins once removed. By homozygosity mapping, the novel locus for ARCI was then localized to an 8.4-cM interval between D17S938 and D17S1879 (fig. 1B and fig. 3).

In both Emirati families, the ARCI loci on chromosomes 2, 3, 14, and 19 were clearly excluded. Moreover, the new locus on chromosome 17p was also excluded, since either obligatory recombination events or lack of homozygosity by descent were found (table 1 and fig. 2). These results were in accordance with the analysis by HOMOG, since the maximum LOD score was found under heterogeneity with  $\alpha_{\max} = 0.50$  (i.e., two families with and two families without linkage of ARCI to D17S945). The findings revealed that at least one further, seventh, ARCI locus must exist. However, because a significant LOD score for linkage was not achieved in these two families, further families with linkage of ARCI to the same unknown region must be investigated, to identify their ARCI loci.

The assumed genetic heterogeneity of ARCI in the four families described here was further tested with the computer program HOMOGM (Bhat et al. 1999). The novel locus on chromosome 17p was analyzed against markers from the previously known regions for ARCI, on chromosomes 2, 3, 14, and 19. Conditional linkage probabilities of 0.99570 and 0.99120 at D17S945 in the Turkish and the German families, respectively, and linkage probabilities of 0.99266 and 0.99003 in the two Emirati families for being without linkage to any of the loci confirmed the genetic heterogeneity and clearly showed that, in the Turkish and German families, ARCI is linked to the region on chromosome 17, in contrast to the two Emirati families.

The interval identified on chromosome 17p contains ~20 known genes and >80 ESTs (Genome Database). A number of these have been shown to be expressed in skin. However, there is no known transcript that is exclusively or mainly expressed in keratinocytes, and no one is an obvious candidate for congenital ichthyosis on the basis of its functional characteristics. The process of formation of the cell envelope and of the lipid-protective layer is complex and characterized by exact chronological regulation during keratinocyte differentiation (Eckert et al. 1997; Robinson et al. 1997; Kanekura et al. 1998; Kawabe et al. 1998; Kim and Bae 1998; Medvedev et al. 1999; Polakowska et al. 1999). There are several possible mechanisms that could lead to impaired cell envelope and lipid-layer formations. These include defects in structural proteins and lipid constituents, failure of enzymes involved, such as the transglutaminase 1, and their cofactors, as well as unknown components required during epidermal differentiation processes. In this respect, proteins involved in transcriptional activity, such as the SNF2-like zinc finger helicase (ZFH), in

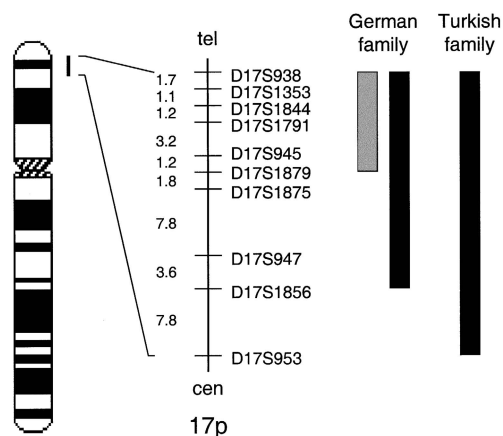

**Figure 3** The localization of the ARCI gene on chromosome 17p. Distances between markers are given in centimorgans according to Dib et al. (1996). The 8.4-cM interval harboring the gene is determined by the flanking markers at D17S938 and D17S1879. In the German family, the black bar represents the interval defined by recombination events. The gray bar shows the interval obtained by homozygosity mapping.

translational activity, such as the translation initiation factor 4A (EIF4A1), or in regulatory processes, such as protein kinase SERK1 and tumor necrosis factor-like TNFSF12, whose genes are located in the ARCI interval, could play a role in the disturbance of epidermal cornification. There is no hint yet, however, at any keratinocyte-specific activity of these proteins that were thus not considered as strong candidates. Further characterization of ESTs in the interval on chromosome 17p and the identification of other transcripts are therefore necessary, to identify candidate genes. The analysis of other families with ARCI will further narrow the interval and allow the positional cloning of the novel gene underlying ARCI.

## Acknowledgments

We thank all four families for their participation in the study. We are grateful to Emeli Bektaş for DNA extraction, Franz Rüschenhoff and Gudrun Nürnberg for their help in computerized analysis of the genotyping data, and Karl Sperling for continued support. The Gene Mapping Center is funded by a grant in aid of the German Human Genome Project (to A.R.). This work was supported by grants from the German support group for ichthyosis, Selbsthilfe Ichthyose e.V., and the sponsoring group Förderer behinderter Menschen (to H.C.H.).

## Electronic-Database Information

Accession numbers and URLs for data in this article are as follows:

Columbia University Genome Center, [ftp://ftp.ebi.ac.uk/pub/software/linkage\\_and\\_mapping/linkage\\_cpmc\\_columbia\\_analyze/](ftp://ftp.ebi.ac.uk/pub/software/linkage_and_mapping/linkage_cpmc_columbia_analyze/) (for linkage analysis software)  
 Génethon, <http://www.genethon.fr/> (for genetic markers and maps)  
 Genome Database, The, <http://gdbwww.gdb.org/> (for marker and gene loci)  
 NCBI, <http://www.ncbi.nlm.nih.gov/> (for BLAST searches, EST data, the Human Gene Map, and the UniGene and SAGE collections)  
 Online Mendelian Inheritance in Man (OMIM), <http://www.ncbi.nlm.nih.gov/Omim/> (for ARCI [MIM 242100 and 242300])  
 Rockefeller University Statistical Genetics, <ftp://linkage.rockefeller.edu/> (for linkage analysis software)

## References

- Aeschlimann D, Paulsson M (1994) Transglutaminases: protein cross-linking enzymes in tissues and body fluids. *Thromb Haemost* 71:402–415
- Bale SJ, Russell LJ, Lee ML, Compton JG, DiGiovanna JJ (1996) Congenital recessive ichthyosis unlinked to loci for epidermal transglutaminases. *J Invest Dermatol* 107:808–811
- Bhat A, Heath SC, Ott J (1999) Heterogeneity for multiple disease loci in linkage analysis. *Hum Hered* 49:229–231
- Deloukas P, Schuler GD, Gyapay G, Beasley EM, Soderlund C, Rodriguez-Tome P, Hui L, et al (1998) A physical map of 30,000 human genes. *Science* 282:744–746
- Dib C, Fauré S, Fizames C, Samson D, Drouot N, Vignal A, Millasseau P, Marc S, Hazan J, Seboun E, Lathrop M, Gyapay G, Morissette J, Weissenbach J (1996) A comprehensive genetic map of the human genome based on 5,264 microsatellites. *Nature* 380:152–154
- Eckert RL, Crish JF, Banks EB, Welter JF (1997) The epidermis: genes on—genes off. *J Invest Dermatol* 109:501–509
- Fischer J, Faure A, Bouadjar B, Blanchet-Bardon C, Karaduman A, Thomas I, Emre S, Cure S, Özgüc M, Weissenbach J, Prud'homme JF (2000) Two new loci for autosomal recessive ichthyosis on chromosomes 3p21 and 19p12-q12 and evidence for further genetic heterogeneity. *Am J Hum Genet* 66:904–913
- Hennies HC, Küster W, Wiebe V, Krebsová A, Reis A (1998a) Genotype/phenotype correlation in autosomal recessive lamellar ichthyosis. *Am J Hum Genet* 62:1052–1061
- Hennies HC, Raghunath M, Wiebe V, Vogel M, Velten F, Traupe H, Reis A (1998b) Genetic and immunohistochemical detection of mutations inactivating the keratinocyte transglutaminase in patients with lamellar ichthyosis. *Hum Genet* 102:314–318
- Hohl D, Aeschlimann D, Huber M (1998) In vitro and rapid in situ transglutaminase assays for congenital ichthyoses—a comparative study. *J Invest Dermatol* 110:268–271
- Huber M, Rettler I, Bernasconi K, Frenk E, Lavrijsen AP, Ponc M, Bon A, Lautenschlager S, Schorderet DF, Hohl D (1995a) Mutations of keratinocyte transglutaminase in lamellar ichthyosis. *Science* 267:525–528
- Huber M, Rettler I, Bernasconi K, Wyss M, Hohl D (1995b) Lamellar ichthyosis is genetically heterogeneous—cases with normal keratinocyte transglutaminase. *J Invest Dermatol* 105:653–654
- Kanekura T, Laulederkind SJ, Kirtikara K, Goorha S, Ballou LR (1998) Cholecalciferol induces prostaglandin E2 biosynthesis and transglutaminase activity in human keratinocytes. *J Invest Dermatol* 111:634–639
- Kawabe S, Ikuta T, Ohba M, Chida K, Ueda E, Yamanishi K, Kuroki T (1998) Cholesterol sulfate activates transcription of transglutaminase 1 gene in normal human keratinocytes. *J Invest Dermatol* 111:1098–1102
- Kim SY, Bae CD (1998) Calpain inhibitors reduce the cornified cell envelope formation by inhibiting proteolytic processing of transglutaminase 1. *Exp Mol Med* 30:257–262
- Kubilus J, Baden HP (1984) Isopeptide bond formation in epidermis. *Mol Cell Biochem* 58:129–137
- Laiho E, Niemi KM, Ignatius J, Kere J, Palotie A, Saarialho-Kere U (1999) Clinical and morphological correlations for transglutaminase 1 gene mutations in autosomal recessive congenital ichthyosis. *Eur J Hum Genet* 7:625–632
- Lander ES, Green P (1987) Construction of multilocus genetic linkage maps in humans. *Proc Natl Acad Sci USA* 84:2363–2367
- Lathrop GM, Lalouel JM (1984) Easy calculations of lod scores and genetic risks on small computers. *Am J Hum Genet* 36:460–465
- Lorand L, Conrad SM (1984) Transglutaminases. *Mol Cell Biochem* 58:9–35
- Medvedev A, Saunders NA, Matsuura H, Chistokhina A, Jetten AM (1999) Regulation of the transglutaminase 1 gene: identification of DNA elements involved in its transcriptional control in tracheobronchial epithelial cells. *J Biol Chem* 274:3887–3896
- Ott J (1991) Analysis of human genetic linkage. Johns Hopkins University Press, Baltimore
- Parmentier L, Blanchet-Bardon C, Nguyen S, Prud'homme JF, Dubertret L, Weissenbach J (1995) Autosomal recessive lamellar ichthyosis: identification of a new mutation in transglutaminase 1 and evidence for genetic heterogeneity. *Hum Mol Genet* 4:1391–1395
- Parmentier L, Lakhdar H, Blanchet-Bardon C, Marchand S, Dubertret L, Weissenbach J (1996) Mapping of a second locus for lamellar ichthyosis to chromosome 2q33-35. *Hum Mol Genet* 5:555–559
- Parmentier L, Clepet C, Boughdene-Stambouli O, Lakhdar H, Blanchet-Bardon C, Dubertret L, Wunderle E, Pulcini F, Fizames C, Weissenbach J (1999) Lamellar ichthyosis: further narrowing, physical and expression mapping of the chromosome 2 candidate locus. *Eur J Hum Genet* 7:77–87
- Peterson LL, Zettergren JG, Wuepper KD (1983) Biochemistry of transglutaminases and cross-linking in the skin. *J Invest Dermatol* 81(suppl):95s–100s
- Polakowska RR, Graf BA, Falciano V, LaCelle P (1999) Transcription regulatory elements of the first intron control human transglutaminase type 1 gene expression in epidermal keratinocytes. *J Cell Biochem* 73:355–369
- Raghunath M, Hennies HC, Velten F, Wiebe V, Steinert PM, Reis A, Traupe H (1998) A novel in situ method for the detection of deficient transglutaminase activity in the skin. *Arch Dermatol Res* 290:621–627

- Robinson NA, Lopic S, Welter JF, Eckert RL (1997) S100A11, S100A10, annexin 1, desmosomal proteins, small proline-rich proteins, plasminogen activator inhibitor-2, and involucrin are components of the cornified envelope of cultured human epidermal keratinocytes. *J Biol Chem* 272:12035–12046
- Russell LJ, DiGiovanna JJ, Rogers GR, Steinert PM, Hashem N, Compton JG, Bale SJ (1995) Mutations in the gene for transglutaminase 1 in autosomal recessive lamellar ichthy-  
osis. *Nat Genet* 9:279–283
- Sandler B, Hashimoto K (1998) Collodion baby and lamellar ichthyosis. *J Cutan Pathol* 25:116–121
- Traupe H (1989) *The ichthyoses: a guide to clinical diagnosis, genetic counselling and therapy.* Springer, Berlin
- Violainen E, Wessman M, Hovatta I, Niemi KM, Ignatius J, Kere J, Peltonen L, Palotie A (2000) Assignment of a novel locus for autosomal recessive congenital ichthyosis to chromosome 19p13.1-p13.2. *Am J Hum Genet* 66:1132–1137