

The 2nd International Symposium on Aircraft Airworthiness (ISAA 2011)

## FHA method for VBV position control function of FADEC system based on aero-engine dynamic model

DING Shuiting<sup>a,b,c,d</sup>, QIU Tian<sup>a,b,c,d,\*</sup>, LIU Xiaofeng<sup>a,b,e</sup>, ZHANG Shuguang<sup>a,b,e</sup>

<sup>a</sup>*Airworthiness Technologies Research Center, Beihang University, Beijing 100191, P.R. China*

<sup>b</sup>*Beijing Key Laboratory on Safety of Integrated Aircraft and Propulsion Systems, Beihang University, Beijing 100191, P.R. China*

<sup>c</sup>*National Key Laboratory of Science and Technology on Aero-Engine Aero-thermodynamics, Beihang University, Beijing 100191, P.R. China*

<sup>d</sup>*School of Jet Propulsion, Beihang University, Beijing 100191, P.R. China*

<sup>e</sup>*School of Transportation Science and Engineering, Beihang University, Beijing 100191, P.R. China*

---

### Abstract

Traditional Functional Hazard Assessment (FHA) method is hard to identify those engine effects which lack of visualization. In order to solve this problem, this paper develops a model-based FHA method for Variable Bleed Valve (VBV) position control function, performs two groups of simulations by using aero-engine dynamic model, and introduces an exemplary FHA for VBV position control function based upon simulation results. The application of this method shows that it is feasible and effective.

© 2011 Published by Elsevier Ltd. Selection and/or peer-review under responsibility of Airworthiness Technologies Research Center NLAA, and Beijing Key Laboratory on Safety of Integrated Aircraft and Propulsion Systems, China. Open access under [CC BY-NC-ND license](https://creativecommons.org/licenses/by-nc-nd/4.0/).

*Keywords:* airworthiness; aero-engine dynamic model; full authority digital engine control system; functional hazard assessment; VBV position control

---

### 1. Introduction

Full Authority Digital Engine Control (FADEC) system directly affects the working conditions of aircraft engines, is a critical system for engine safety [1]. Therefore, FADEC system safety analysis and

---

\* Corresponding author. Tel.: +86-13426025028.

E-mail address: [autumn@sjp.buaa.edu.cn](mailto:autumn@sjp.buaa.edu.cn).

design techniques are hot topics in the aero-engine control field [1-6].

Researchers have studied the Functional Hazard Assessment (FHA) application in the engine controller [2], aircraft bleed air system [7], aircraft brake system [8], aircraft hydraulic and power systems [9], A109 helicopter power system [10], aircraft system [11-12], aircraft landing gear software [11], ACE missile system [11], etc. Traditional FHA methods which used in these cases are empirical. But as will be discussed further below, FHA for Variable Bleed Valve (VBV) position control function failure is hard to perform that way.

### Nomenclature

|               |   |
|---------------|---|
| $EGT$         | Exhaust gas temperature                           |
| $EGT_{limit}$ | Limit value of exhaust gas temperature            |
| $N1$          | Low speed rotor speed                             |
| $N1_{limit}$  | Limit value of low speed rotor speed              |
| $N1_r$        | Low speed rotor corrected speed                   |
| $N1_{rg}$     | Expected value of low speed rotor corrected speed |
| $N2$          | High speed rotor speed                            |
| $N2_{limit}$  | Limit value of high speed rotor speed             |
| $N2_r$        | High speed rotor corrected speed                  |
| $Ps3$         | High pressure compressor outlet static pressure   |
| $P_{VBV}$     | VBV position                                      |
| $T2$          | Fan inlet temperature                             |
| $T25$         | High pressure compressor inlet temperature        |
| $T4$          | High pressure turbine inlet temperature           |
| $W_f$         | Fuel mass flow rate                               |

The compressors of aero-engine are designed for design point, which highlights the cruise flight phase performance. When engine operating state is deviate from design state, the compressors need systems that keep the airflow within the limits and prevent stall and surge [13]. To ensure this, one of the effective ways is introduce VBV system, which had been widely used in modern high bypass turbofan engine and mostly located at the exit of the booster. For VBV trade energy utilization efficiency for booster surge margin, VBV position control function influences both engine performance and engine safety. Therefore, this function should reflect balance between engine performance and safety. If VBV position control function performed incorrectly, it will impact on both engine performance and engine safety. Nevertheless, VBV position control function should satisfy the lowest safety requirements wrote in FAR33. For this reason, the method used in this paper which only studies the safety factor is reasonable.

Aero-engine failure mechanism is very complex in transient process, which makes safety analysis of aero-engine is hard to accomplish. VBV position control function failure would influence the whole engine by the engine re-match process, which controlled by the engine non-linear equations. Experiences,

it seems, are not enough to analyze impacts of VBV position control function failure on engine. To solve this problem, this paper develops a VBV position control functional hazard assessment method based on aero-engine dynamic model, as a complement for traditional experience-based methods. As discussed below, the aero-engine dynamic model could detect complex engine effects of the VBV position control function failure and provides visual information for FHA of VBV position control function.

## 2. Safety requirements

Safety requirements from airworthiness regulations are inputs of FHA. Safety requirements for turbofan engine control system from FAR 33 can be collected into Table 1. VBV position control function failure hazard level classification should be based on Table 1.

## 3. Tool and data requirements of FHA for VBV position control function

According to FHA table format in SAE ARP 4761[17], we rebuild engine control system FHA table format which is shown in Table 2. For VBV position control function hazard assessment, 'Function' column of Table 2 should fill with 'VBV position control'. 'Failure condition' column should traverse every VBV function failure conditions which are shown in Fig. 1 row by row. For every failure condition, 'Phase' column should traverse every operation phases row by row. For every operation phases of VBV function failure conditions, 'Engine effects' column should fill with engine effects. Every engine effect should be classified according to safety requirements (Table 1.), meanwhile the classification should be filled in 'Classification' column, reference materials and verify methods should be filled in 'Reference to/Supporting material' and 'Verification' columns subsequently.

Little effort is saved in the analysis of engine effect, viz. the analysis of 'Engine effects' column for each row of Table 2. To accomplish this, as discussed in introduction, specific tool and data are necessary.

### 3.1. Tools requirements analysis

Aero-engine is a complex aero-thermodynamics system controlled by the engine non-linear equations. Any VBV position control output exception has an impact on engine working condition caused by the engine re-matching. Aero-engine aero-thermodynamics dynamic model is a powerful tool which could find operating point rapidly. Therefore, in order to evaluate the impact of VBV position control output on engine working condition, an aero-engine dynamic model is necessary.

### 3.2. Data requirements analysis

Output of VBV position control affects engine working condition which interacts with engine parts performance. In order to evaluate engine working condition under different VBV position control output, maps of each part are necessary. In the stage of concept design, parts design have not started yet, no accuracy part maps are available. But the maps of similar configuration parts could reflect main character of these parts. FHA should focus on the trend of function failure influence on engine working condition, rather than the accurate values. Therefore, similar configuration parts maps are enough and required consequently. Besides, we could not expect simulation resolve every problem in FHA, so experiential knowledge is needed as well.

Table 1. Safety requirements for engine control system from FAR 33 [14-16]

| Hazard level       | Engine effects   | Probability range   |
|--------------------|--|---|
| Hazardous          | (1) Non-containment of high-energy debris;   | 10 <sup>-7</sup> ~10 <sup>-9</sup> per engine flight hour |
|                    | (2) Concentration of toxic products in the engine bleed air intended for the cabin sufficient to incapacitate crew or passengers;  |   |
|                    | (3) Significant thrust in the opposite direction to that commanded by the pilot;   |   |
|                    | (4) Uncontrolled fire;   |   |
|                    | (5) Failure of the engine mount system leading to inadvertent engine separation;   |   |
|                    | (6) Complete inability to shut the engine down.  |   |
| Major              | (1) Controlled fires (that is, those fires brought under control by shutting down the engine or by on-board extinguishing systems);  | 10 <sup>-5</sup> ~10 <sup>-7</sup> per engine flight hour |
|                    | (2) Case burnthrough when it can be shown that there is no propagation to hazardous engine effects;  |   |
|                    | (3) Release of low-energy debris when applicants can show that the release does not progress to a hazardous engine effect;   |   |
|                    | (4) Vibration levels that result in crew discomfort;   |   |
|                    | (5) Concentration of toxic products in the engine bleed air for the cabin sufficient to degrade crew performance;  |   |
|                    | (6) Thrust in the opposite direction to that commanded by the pilot, below the level defined as a hazardous engine effect;   |   |
|                    | (7) Generation of thrust greater than maximum rated thrust;  |   |
|                    | (8) Loss of engine support loadpath integrity without actual engine separation;  |   |
|                    | (9) Significant uncontrollable thrust oscillation;   |   |
|                    | (10) Loss of thrust control (LOTC);  |   |
|                    | (11) An effect whose severity falls between minor and hazardous engine effects.  |   |
| Minor <sup>1</sup> | An engine failure in which the only consequence is partial or complete loss of thrust or power (and associated engine services) from the engine will be regarded as a minor engine effect. | —   |

Table 2. FHA table format

| Function | Failure condition | Phase | Engine effects | Classification | Reference to \ Supporting material | Verification |
|----------|-------------------|-------|----------------|----------------|------------------------------------|--------------|
|----------|-------------------|-------|----------------|----------------|------------------------------------|--------------|

<sup>1</sup> ‘Minor engine effect’ was defined in FAR 33.75 [14-15] but unexpected engine shutdown caused by engine control system is one kind of LOTC. This paper only focuses on VBV control function, a function of engine control system, so ‘minor engine effect’ definition in Table 1 is for reference only.

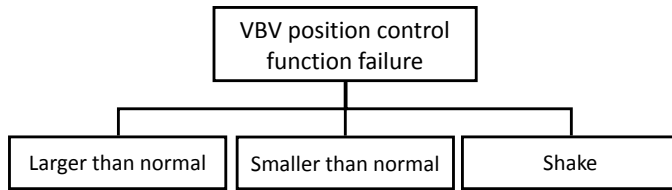

Fig. 1. VBV position control function failure conditions

**4. Turbofan dynamic model**

*4.1. Outline*

The turbofan dynamic model consists of the static elements: Inlet, Fan, Booster, VBV, High pressure compressor (HPC), Combustor, High pressure turbine (HPT), Low pressure turbine (LPT), Bypass, main and bypass Nozzle, which are modeled as lumped parameter thermodynamic systems, represented by performance maps, constant coefficients, and thermo and aero-dynamic relationships and the dynamic elements which include the following: Low speed rotor and High speed rotor. In this model, the rotor dynamics (for the high speed and low speed rotors) is represented by the equation of conservation of angular momentum. Fig. 2 shows the model structure.

*4.2. Engine fuel control loop*

The engine fuel control loop used in simulations is shown in Fig. 3. Where

$$\left(\frac{W_f}{Ps3}\right)_r = \left(\frac{W_f}{Ps3}\right) \times \sqrt{288.15/T2} \tag{1}$$

so

$$W_f = \left(\frac{W_f}{Ps3}\right)_r \times \sqrt{T2/288.15} \times Ps3 \tag{2}$$

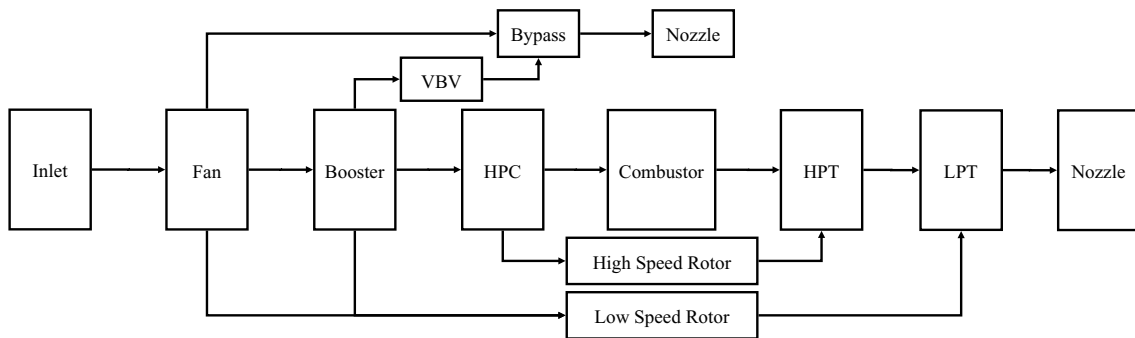

Fig. 2. Turbofan dynamic model

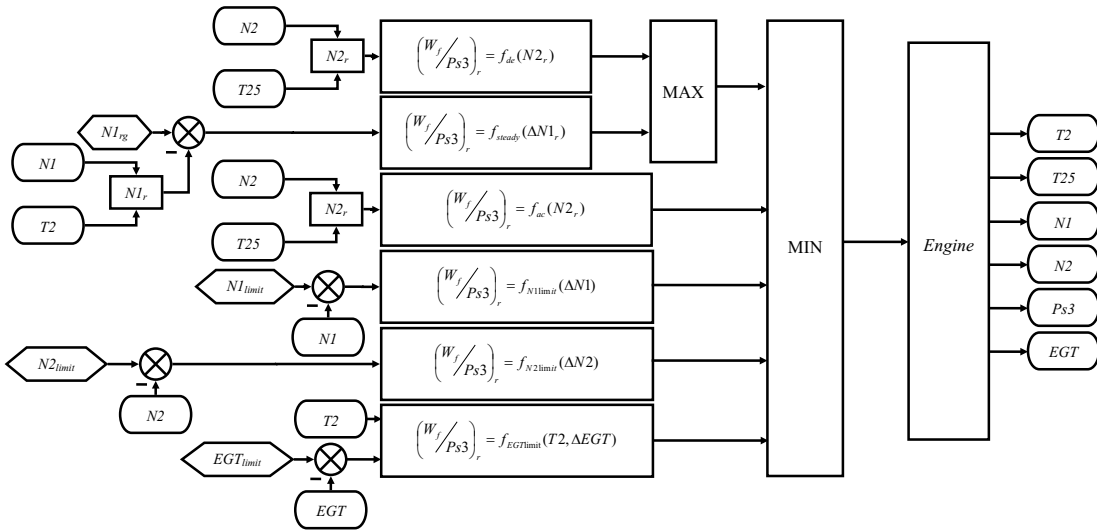

Fig. 3. Engine fuel control loop

4.3. VBV position control loop

The VBV position control loop used in simulations is shown in Fig. 4. The position of VBV is controlled by  $N2_r$ , during the analysis we don't separate the accelerating procedure and decelerating procedure and use a common plan of VBV position control.

5. Simulations

5.1. Control plans for simulate VBV position control function failure

VBV position control function failure conditions are shown in Fig. 1. VBV position control function failure is considered by changing VBV position control plans, which are illustrated in Table 3, while simulations.

5.2. Simulation inputs & results

This paper performed two groups of simulations called simulation 1 and simulation 2 which represent typical acceleration and deceleration respectively. Inputs of these simulations are illustrated in Table 4. Main results of these simulations are shown in Fig. 6 and Fig. 7 respectively. For the sake of clarity, data points displayed in these figures were diluted, but the curves haven't been simplified.

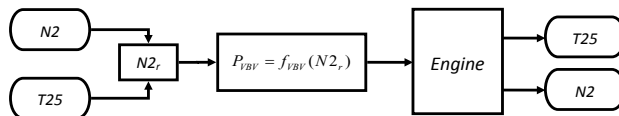

Fig. 4. VBV position control loop

Table 3. Corresponded VBV position control plans for simulate VBV position control function failure

| VBV position control function failure conditions | Corresponded VBV position control plans  |
|--|--|
| Larger than normal                               | Amplified by multiply a fixed scale factor (scale factor is 1.2), maximum value is 100%, shown in Fig. 5(a); or<br>Always open, shown in Fig. 5(b).  |
| Smaller than normal                              | Shrunk by multiply a fixed scale factor (scale factor is 0.8), shown in Fig. 5(c) ; or<br>Always closed, shown in Fig. 5(d).   |
| Shake  | Normal VBV position multiplied by random scale factors, which ordered uniformity distribute $U(0.5,1.5)$ , maximum value is 100%, random scale factors used in simulations are shown in Fig. 5(e). Changing control plan are shown in Fig. 5(f). |

Table 4. Inputs of simulations

|                           | Simulation 1                            |             | Simulation 2          |             |
|---------------------------|---|-------------|-----------------------|-------------|
| Environment               | International Standard Atmosphere (ISA) |             | ISA                   |             |
|                           | Sea level                               |             | Sea level             |             |
|                           | Static                                  |             | Static                |             |
| Process property          | Acceleration                            |             | Deceleration          |             |
| Initial condition         | Steady at 58.1% $NI_r$                  |             | Steady at 100% $NI_r$ |             |
| Manipulate record         | $NI_{rg}=58.1\%$                        | Time =0s    | $NI_{rg}=100\%$       | Time=0s     |
|                           | $NI_{rg}=100\%$                         | 0s<Time≤15s | $NI_{rg}=58.1\%$      | 0s<Time≤15s |
| Simulate time step length | 0.001s                                  |             | 0.001s                |             |

## 6. Analysis

FHA is performed in the stage of concept design, which characteristic by no design details are available. As data we used in simulations are not absolutely accurate, therefore, changing trend of simulate results of different failure conditions are more important than numerical value itself.

### 6.1. Engine effects of 'larger than normal' function failure analysis

#### 6.1.1. Accelerate process

As we can see in Fig. 6, during accelerate process, for 'larger than normal' failure condition, operate parameters are almost the same with normal condition. But for 'always open' failure condition, except for booster surge margin is increasing significantly,  $NI_r$ , thrust,  $T4$ , fan surge margin and HPC surge margin are decrease at the same time. Decrease range is especially large for thrust (about 5%).

Reasons of parameters decreased decrease are identical. And the reason is that  $N2_{limit}$  control loop was active. If VBV always open, extra energy lose is introduced which is unnecessarily in most operate phases especially when rotating speed is high. This part of energy lose is counted on low speed rotor, so the rotating speed difference between high and low speed rotor is increasing, as a result,  $N2$  is larger than  $N2_{limit}$  when  $NI_r$  is 100% in that environment, therefore,  $N2_{limit}$  control loop determines the  $NI_r$ .

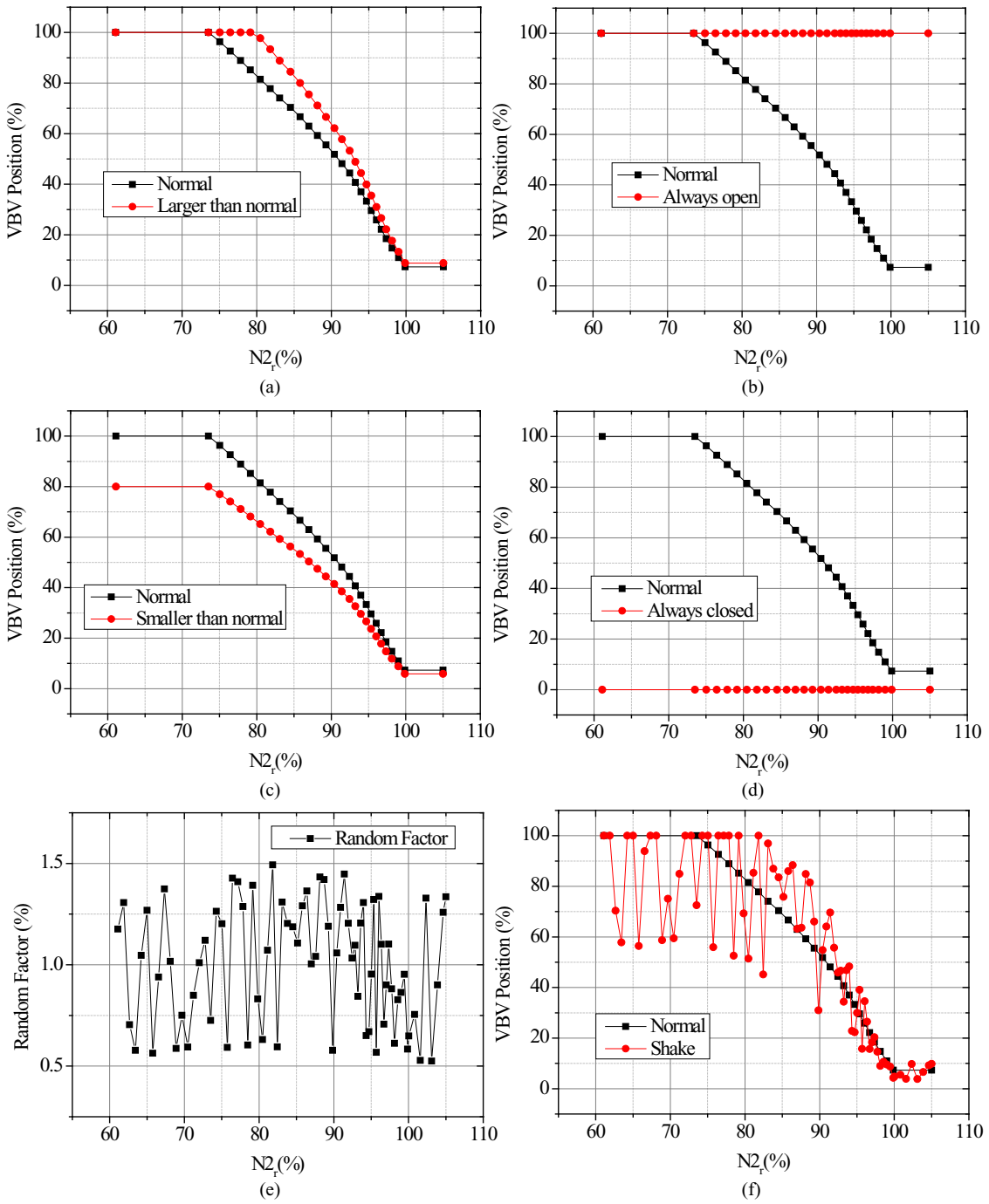

Fig. 5. Control plans for simulate VB position control function failure



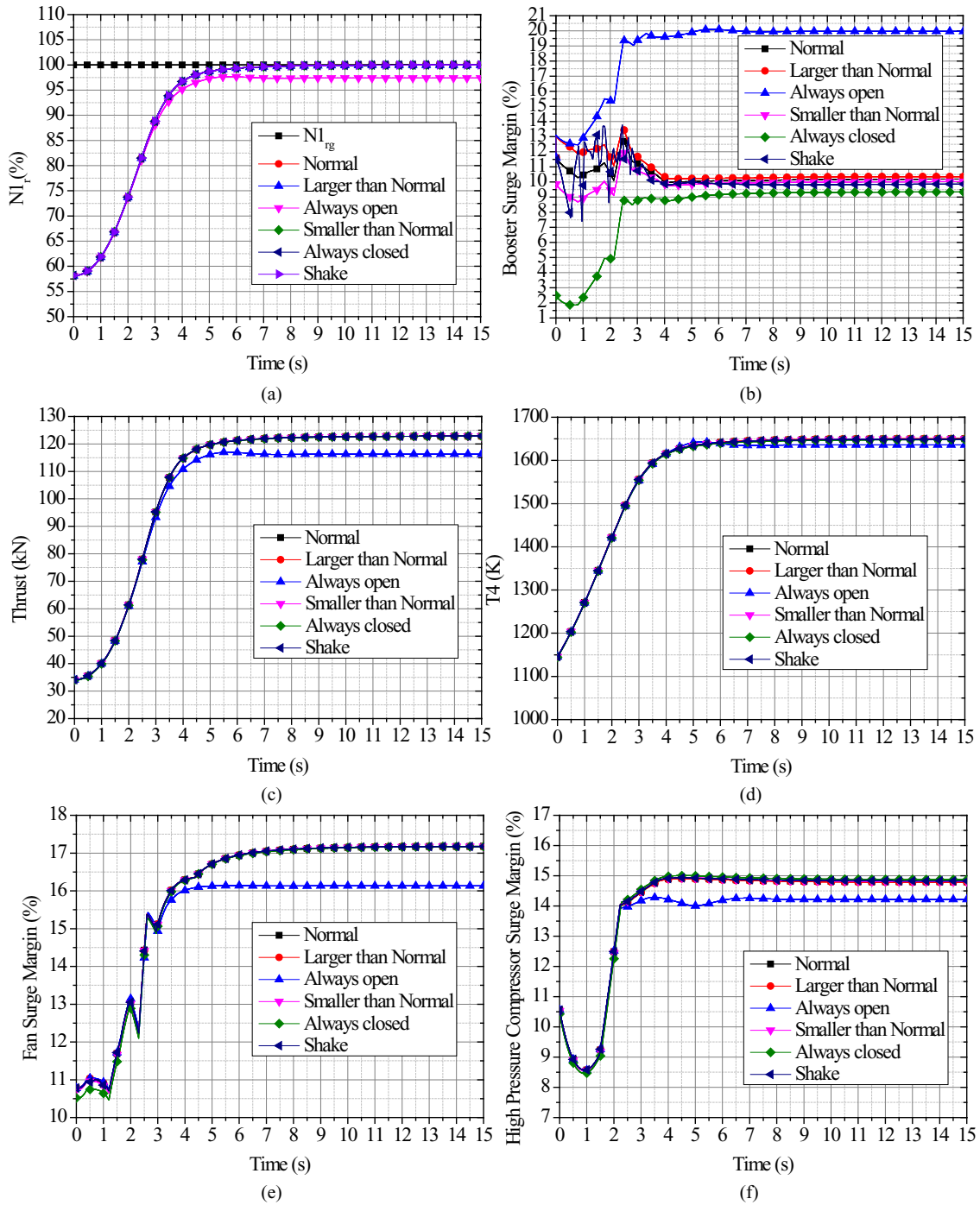

Fig. 6. Results of simulation 1

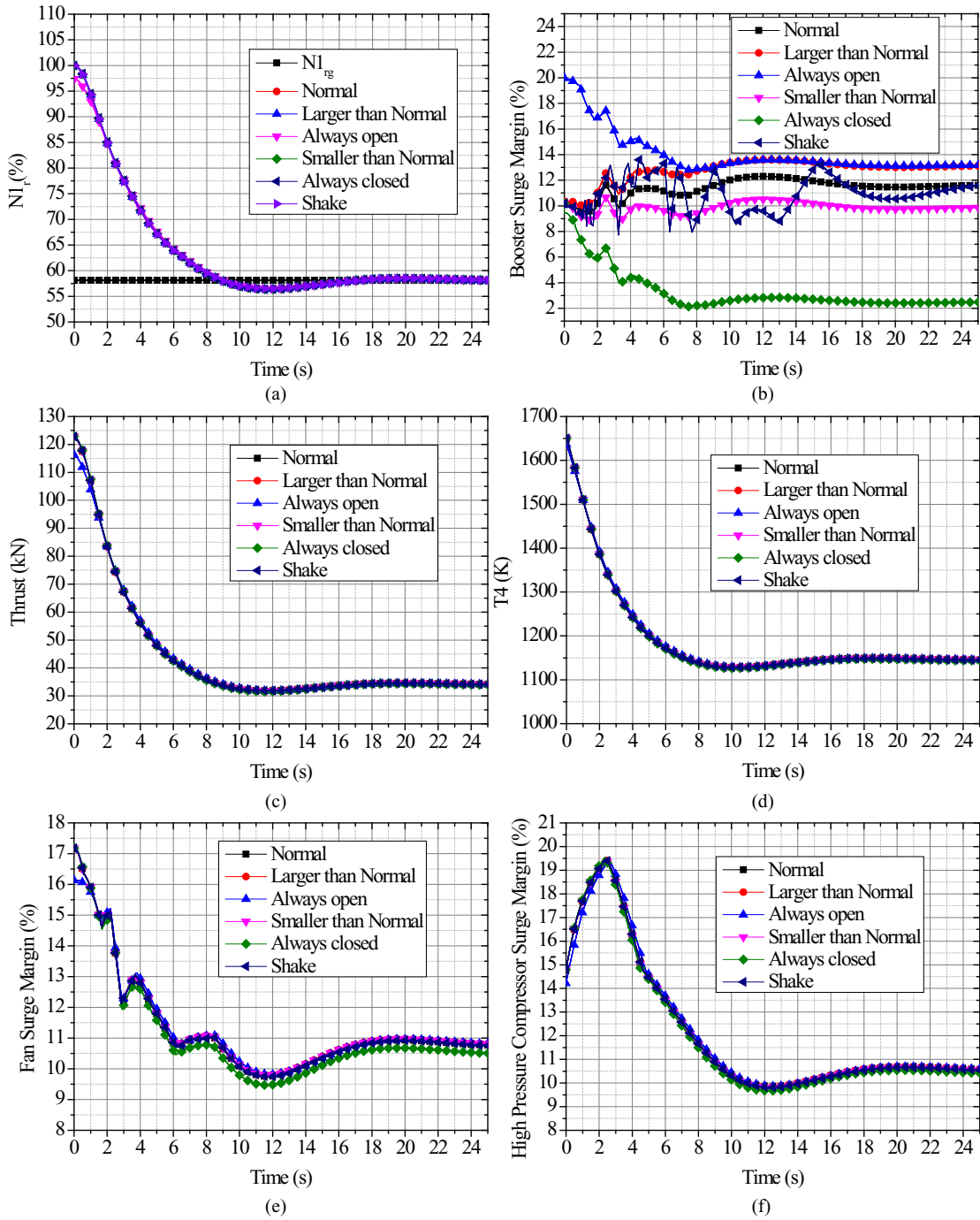

Fig. 7. Results of simulation 2

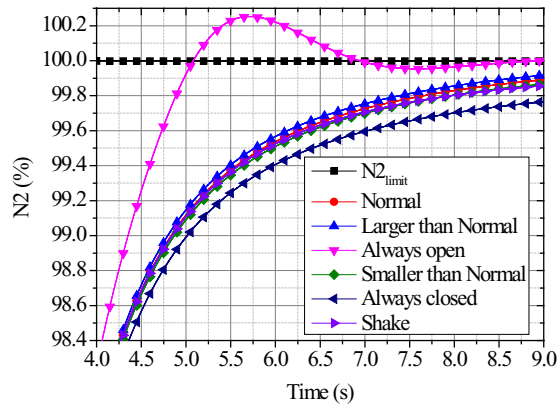

Fig. 8.  $N_2$  curves under various VBV position control function failure conditions (extract from results of simulation 1)

$N_2$  curves are shown in Fig. 8, as we can see in the VBV failure condition of ‘always open’, after  $N_2$  surpasses  $N_{2limit}$  for about 1.8 seconds,  $N_2$  steady at  $N_{2limit}$ . Meanwhile, as Fig. 6(a) illustrates, under VBV ‘always open’ failure condition, the  $NI_r$  is 97.4%. Under other VBV failure conditions,  $N_2$  is lower than  $N_{2limit}$  at 9s.

Therefore, the ‘Larger than normal’ function failure condition could result in those unexpected engine effects below:

- Loss of thrust control (LOT), in the real system whether LOT happens depends on the real system characteristic;
- The stable working margin of fan and HPC is decreasing;
- $N_2$  has surpassed  $N_{2limit}$  shortly.

### 6.1.2. Decelerate process

As we can see in Fig. 7, during the decelerate process, for ‘larger than normal’ and ‘always open’ failure conditions, booster surge margin is increasing and it’s a safe effect. Besides, the impact on  $NI_r$ , thrust,  $T_4$ , fan surge margin and HPC surge margin are not significant.

## 6.2. Engine effects of ‘smaller than normal’ function failure analysis

### 6.2.1. Accelerate process

As we can see in Fig. 6, during accelerate process, for ‘smaller than normal’ and ‘always closed’ failure conditions,  $NI_r$ , thrust,  $T_4$ , fan surge margin and HPC surge margin are almost the same with normal condition. But the impact on booster surge margin is large (9% lower than normal condition maximum), under the failure condition of ‘always closed’.

Therefore, the ‘smaller than normal’ function failure condition could result in the stable working margin of booster decrease.

### 6.2.2. Decelerate process

Same as the accelerate process, it’s unnecessary to go into details.

## 6.3. Engine effects of ‘shake’ function failure analysis

As we can see in Fig. 6 and Fig. 7, ‘shake’ failure conditions in simulation 1 and simulation 2 don’t

have significant impact on  $NI_r$ , trust,  $T4$ , fan surge margin and HPC surge margin, but they do have impact on booster surge margin: it shakes corresponding to VBV position and the amplitude depends on shake amplitude of VBV position.

Obviously, for real system, VBV position shakes could result in every engine effect happened in ‘larger than normal’ and ‘smaller than normal’ function failure, even more. In simulation 1 and simulation 2 no special hazard were found. The diversity of shake modes makes that the simulation results shown in this paper are for reference only.

#### 6.4. FHA output table

According to the safety requirements shown in Table 1 and FHA table format (Table 2), considering the simulation results we have, we could conclude Table 5 with less experience. In order to underline the main purpose of this paper, last two columns of Table 2 are omitted in Table 5.

Table 5. Output table of FHA for VBV position control function

| Function             | Failure condition   | Phase                        | Engine effects  | Classification      |
|----------------------|---------------------|------------------------------|---|---------------------|
| VBV position control | Larger than normal  | Acceleration                 | At the end of acceleration, VBV position is larger could result in thrust lose significantly, fan and HPC stable working margin decrease lightly, $N2$ exceed $N2_{limit}$ shortly. Whether it could result in LOTC depends on real system characteristic, should research again.   | Minor to Major      |
| VBV position control | Larger than normal  | Deceleration                 | Don't have safety influence on engine almost.   | No safety influence |
| VBV position control | Smaller than normal | Acceleration<br>Deceleration | In both acceleration and deceleration processes, VBV position is smaller could result in booster surge margin decrease significantly, stall and surge could happen to booster, these kind of phenomena could result in engine vibration, which is enough to makes the crew uncomfortable.   | Major               |
| VBV position control | Shake               | Acceleration<br>Deceleration | In both acceleration and deceleration process, VBV position shake could result in stable working margin of compress system decrease, switch between rotating speed limit control loop and other fuel control loops again and again. As a result, over rotating and thrust shake could happen. These kinds of phenomena could result in engine vibration, which is enough to makes the crew uncomfortable. | Major               |

## 7. Conclusion

Traditional FHA method is hard to use in VBV position control function failure hazard assessment, for not all engine effects are obviously. To solve this problem, this paper developed a method which introduces aero-engine dynamic model in the FHA process, then two groups of simulations were performed, simulation results indicate that:

- This model could identify engine effects of VBV position control function failure;
- Model analysis method of functional hazard for VBV position control function could ascertain engine effects hazard level by quantitative analysis, provides visual information for the assessment and could be a supplement for expert experience.

## Acknowledgements

The authors would like to thank the reviewers for their constructive and insightful suggestions for further improving the quality of this paper. This work is supported by the Innovation Plan of Aero Engine Complex System Safety by the Ministry of Education Chang Jiang Scholars of China (Grant No.IRT0905).

## References

- [1] Frankenberger III C E. Survivable Engine Control Algorithm Development (SECAD). IEEE Aerospace Conference. 2002; 3015-3020.
- [2] Wilkinson P J, Kelly T P. Functional hazard analysis for highly integrated aerospace systems. IEEE Certification of Ground Air Systems Seminar. 1998; 4/1-4/6.
- [3] HAN Xiaoqi. Aircraft engine control system safety assessment. Master's thesis, Civil Aviation University of China, 2009. [in Chinese]
- [4] Schwamm F. FADEC computer systems for safety critical application. ASME The 1998 International Gas Turbine & Aeroengine Congress & Exhibition. 1998; 1-8.
- [5] Hjelmgren K, Svensson S, Hannius O. Reliability analysis of a single-engine aircraft FADEC. IEEE Reliability and Maintainability Symposium. 1998; 401-407.
- [6] Jambon F, Girard P, A T-Ameur Y. Interactive System Safety and Usability enforced with the development process. Journal of Engineering for Human-Computer Interaction. 2001; 39-55.
- [7] LIU Jianjun, SUN Youchao. Application of functional hazard assessment in large complex system. Journal of Civil Aircraft Design and Research. 2004; (1): 35-40. [in Chinese]
- [8] SUN Chunlin, LIU Dongyu. Functional hazard analysis for nose wheel steering of civil aircraft. Journal of Machinery Design & Manufacture. 2011; (2): 89-91. [in Chinese]
- [9] XIAO Xiang, WANG Huasheng. Hydraulic system FHA based on civil aircraft safety assessment. Journal of Civil Aircraft Design and Research. 2006; (4): 18-22. [in Chinese]
- [10] CHEN Shengbin; ZHOU Xiaoguang. "4F" Technique Application and Lessons Learned in the Helicopter Development. Journal of Helicopter Technique. 2008; (1): 24-29. [in Chinese]
- [11] Clifton A. Ericson. Hazard Analysis Techniques for System Safety. Hoboken: John Wiley & Sons Inc, 2005.
- [12] SUN Youchao, LIU Jianjun, LIANG Li, et al. Research on application of functional hazard assessment in civil aircraft safety design. High-level Forum of key technologies of large aircraft and Chinese Society of Aeronautics and Astronautics Annual Conference Proceedings 2007. 2007. [in Chinese]
- [13] Andreas Linke-Diesinger. Systems of commercial turbofan engines: an introduction to systems functions. Heidelberg: Springer, 2008.
- [14] FAA e-CFR 14 part 33. Airworthiness Standards: Aircraft engines. Washington, D.C.: U.S. Department of Transportation FAA, 2009.
- [15] FAA AC33. 75-1A. Safety Analysis: Guidance Material For 14 CFR 33.75. Washington, D.C.: U.S. Department of Transportation FAA, 2007.
- [16] FAA AC33. 28-1. Aircraft Engines: Electrical and Electronic Engine Control Systems. Washington, D.C.: U.S. Department of Transportation FAA, 2001.
- [17] SAE ARP 4761. Guidelines and methods for conducting the safety assessment process on civil airborne systems and equipment. Warrendale: SAE Inc., 1996.