

Available online at www.sciencedirect.com**ScienceDirect**

Procedia Engineering 63 (2013) 327 – 335

**Procedia
Engineering**www.elsevier.com/locate/procedia

The Manufacturing Engineering Society International Conference, MESIC 2013

Implementation of the iDMU for an aerostructure industrialization in AIRBUS

Menéndez, J.L.^a, Mas, F.^a, Servan J.^a, Arista R.^a, Ríos, J.^{b,*}^aAIRBUS, Av. García Morato s/n, 41011, Sevilla, Spain.^bUniversidad Politécnica de Madrid, José Gutiérrez Abascal 2, 28006 Madrid, Spain.

Abstract

AIRBUS Military has undertaken a project to implement the industrial Digital Mock-Up (iDMU) concept to support the industrialization process of a medium size aerostructure. Within the framework of a collaborative engineering strategy, such project is part of the efforts to deploy Digital Manufacturing as a key technology for the industrialization of aircrafts assembly lines. The project has confirmed the potential of the iDMU to improve the industrial design process in a collaborative engineering environment. This communication presents the main project objectives, the key methodological points, the main project achievements and the next additional developments to increase the scope and benefits of the iDMU concept.

© 2013 The Authors. Published by Elsevier Ltd. Open access under [CC BY-NC-ND license](https://creativecommons.org/licenses/by-nc-nd/4.0/).

Selection and peer-review under responsibility of Universidad de Zaragoza, Dpto Ing Diseño y Fabricacion

Keywords: collaborative engineering; concurrent engineering; industrial DMU.

1. Introduction

Digital Manufacturing techniques are part of the current industrial processes in the aerospace industry, (Delpiano et al, 2002), (Butterfield et al, 2007), (Van Wijk et al, 2009), (Menendez et al, 2012). In this area of knowledge, AIRBUS Military carried out a project to industrialize the Final Assembly Line (FAL) of the A400M military transport aircraft. From the experience gained in that project, the iDMU (industrial Digital Mock-up) concept was coined, (Menendez et al, 2012). An iDMU gathers all the product, processes and resources information: geometrical and technological, to model a virtual assembly line. As a result, an iDMU provides a

* Corresponding author. *E-mail address:* jose.rios@upm.es

single platform to define and validate the assembly line industrial design. One of the main benefits of an iDMU is the reutilization of its elements in the multiple and different tasks of the assembly line industrial design.

AIRBUS Military envisions the iDMU as the main enabler of the Collaborative Engineering policy being fostered at present, (Mas et al, 2013). An iDMU provides a common virtual environment for all the aircraft development stakeholders. This approach to Collaborative Engineering includes the Functional Design and the Industrial Design as parts of a single design process. Both designs progress in parallel in a way that the Functional Design and Industrial Design influence each other. That is, the aircraft design has to be optimized at large for being industrialized. This single collaborative design process is in essence a socio-technical process (Lu et al, 2007), in which stakeholders evaluate different and frequently opposing perspectives about the target aircraft. This process is mainly a negotiation, based in analyzing in common the different perspectives put forward and managing the conflicts, in order to allow a change of the perspectives to reach consensual agreements until every conflict is solved.

Following this model, the iDMU provides the common virtual environment in which the functional and industrial perspectives can be shared by the stakeholders. In which the common analysis and conflict management can be done, and agreed solutions can be validated by suitable tools and simulations of the product, the processes and the resources.

AIRBUS Military has undertaken a project to implement this iDMU concept as an enabler of the Collaborative Design approach for the industrialization of the A320Neo Fan Cowls (Figure 1). This aerostructure was chosen because the following reasons: it is a medium size aerostructure less prone to pose performance problems for the PLM tools; its industrialization includes two technological processes: composites manufacturing and final assembly line; being a component of minor configuration complexity allows to focus all the efforts in the implementation and exploitation of the iDMU avoiding the troubles of a complex configuration management.

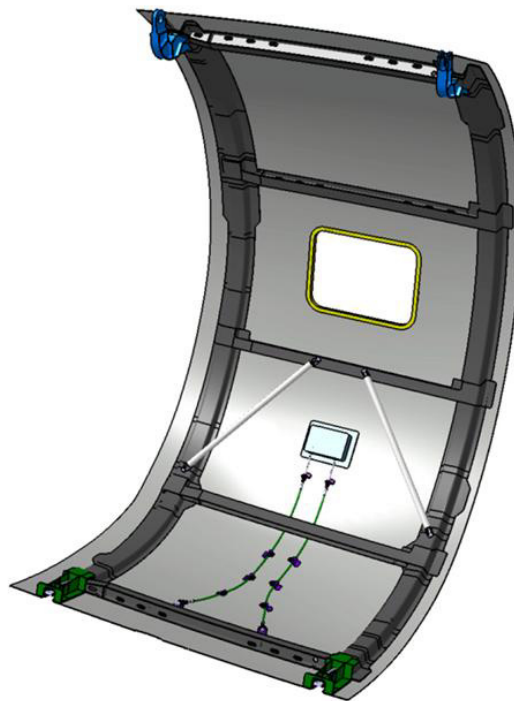

Figure 1. A320 Neo Fan cowl. (Not a real DMU due to confidentiality)

According to the above, the project has the following three main objectives:

1. To implement a workable iDMU suitable to provide the single virtual environment for the collaborative design of the A320Neo Fan Cowl. This includes the definition of the architecture of the iDMU and the building of a real iDMU containing the complete industrial design of the Fan Cowl.
2. To assess the benefits of the iDMU concept compared to the usual practices for the Industrial design.
3. To check the advantage of preparing the shop floor Work Instruction exploiting the information resulting of the industrial design stored in the iDMU.

To check the advantage of preparing the shop floor Work Instruction exploiting the information resulting of the industrial design stored in the iDMU.

2. Current practices

AIRBUS Military is using the Digital Manufacturing techniques for the industrialization of aircrafts assembly lines along the past ten years. Along this period AIRBUS Military has not limited itself to be a Digital Manufacturing final user, but has worked also to build a body of knowledge and methodology, (Menendez et al, 2012), (Mas et al, 2013), (Mas et al, 2012), (Mas et al, 2012), (Rios et al, 2011), (Mas et al, 2009), (Mas et al, 2008). This process is carried out through two differentiated set of activities: on the one hand there is the 3D design, virtual and ergonomics validation of the assembly line, and on the other hand the validation and refinement of the assembly line design to accomplish the planned tack time and resource optimization. Until now, each one of this two set of activities are conducted in to different environments. The AIRBUS PLM system is based on Dassault Systemes solutions, the 3D assembly line design and validation is executed in a CATIA/DELMIA environment and the tack time validation and resource optimization in a DELMIA PROCESS ENGINEER (DPE)/QUEST environment, (Menendez et al, 2012). Currently the two environments are separated ones, and work is done in parallel in each one.

The DPE environment is used to manage the assembly line process structure, the assembly operations time analysis, the validation of the tack time and resources optimization at the assembly stations level. AIRBUS Military has made customizations of DPE for the main aircrafts under production, (Rios et al, 2011). Under the same conceptual frame, DPE has to be customized to each aircraft particularity.

QUEST is a finite events simulator. QUEST model of the complete assembly line allows simulating the materials flow through the assembly line. The model can be used as a “what if” tool to test the performance of different assembly line configurations. A stress analysis of the assembly line can also be done simulating different scenarios with hypothesis of delays of input components and failures of resources.

According AIRBUS Military PLM methodology, the above Digital Manufacturing techniques and tools support the Conceptual and Development phases of the Aircraft Design process. At the end of the Development phase, the functional and industrial design of the aircraft are totally finished and detailed. In the Documentation phase, work instructions for the shop floor are prepared and released.

Currently this collaborative design process has the main shortcoming discussed next.

The assembly processes of an assembly line are managed in unique platform shared by all the stakeholders. Though, the QUEST models are not integrated in this platform. The assembly line configuration has to be defined again in the QUEST model and the assembly process has to be exported from DPE and imported into the QUEST model on demand.

There is no integration between the 3D environment and DPE. In the 3D environment the work is done case by case. Each assembly process is analyzed and simulated one by one. This is done in a specific CATIA file for each process. In each file, it is necessary to build the specific DMU of the product and resources context in which the assembly process is going to be analyzed and validated. For instance, the two following figures illustrate the validation of a particular assembly operation. Figure 2 illustrates a problem found by simulating the assembly of the latches of the fan cowl. It is not possible to apply the torque to the bolts securing the latch mechanism as the standard torque meter collides with the surrounding parts.

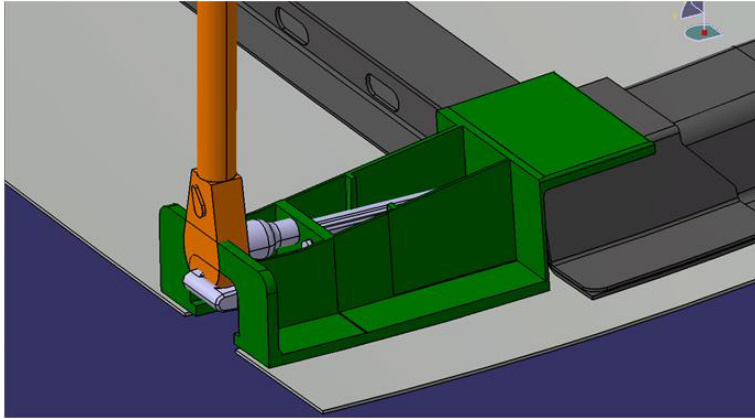

Figure 2. Torque meter collides with surrounding parts. (Not a real DMU due to confidentiality)

Figure 3 illustrates the solution, arrived at collaboratively, consisting in a new housing allowing to have access to the securing bolts by an adaptor.

The process to define and validate collaboratively the latch assembly operation is based on specific CATIA files and DELMIA simulations, which are managed separately without any relation with the assembly operation in DPE. Working in such way the reuse of the DMU of the product and resources context of each assembly process is low.

Once the functional and industrial design is done, in the final phase of documentation, shop floor work instructions are prepared, also case by case and apart from the assembly process 3D analysis. Only snapshots from the DMU in the process CATIA files are used to illustrate the work instructions (WI). This way of working results in a separate management of the WIs from the assembly operation defined in DPE.

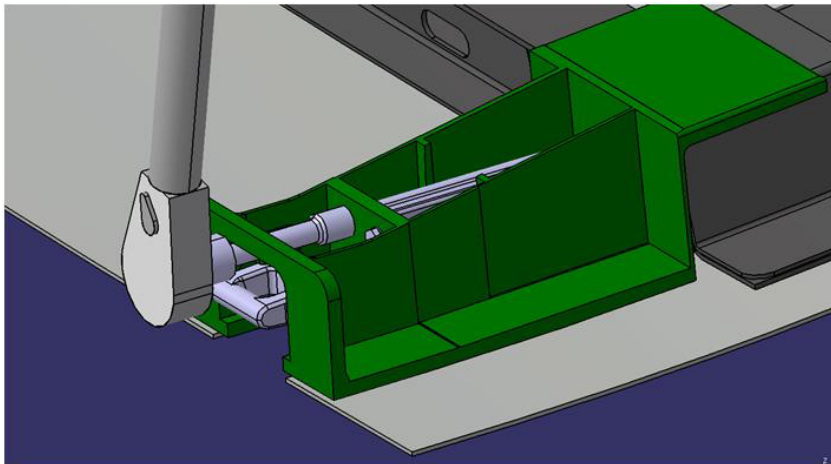

Figure 3. Torque meter collision fixed. (Not a real DMU due to confidentiality)

The main technological advancement launch in this project is to integrate the 3D and the DPE environments in a single environment in which all the design activities are done by all the stakeholders working collaboratively in the same platform. In this platform, all the 3D analysis and simulations made for an assembly process can be stored

and linked to it, and reutilization of this 3D information can be improved very much. This is a key step in the PLM deployment strategy recommended by one of the most reputed advisor in PLM, (IDC Insights White Paper. 2012).

3. Methodology

The integration of the 3D and the process structure in a single platform poses some big challenges discussed in the following paragraphs.

First of all, the product DMU structure is managed in a PDM system. The iDMU needs to be managed outside of such PDM system. This situation demands a specific solution to manage the product DMU in the iDMU. Similar situation occurs with the Resources DMU, also vaulted in the PDM system.

The second main challenge was to define a methodology to associate product and resources to the assembly process, so the suitable product and resource context for each assembly process are correctly associated. This must be done independently of the level of the process in the process structure.

A third challenge was to choose between the Dassault Systemes tools, those that are best suited for implementing the A320neo Fan Cowl iDMU.

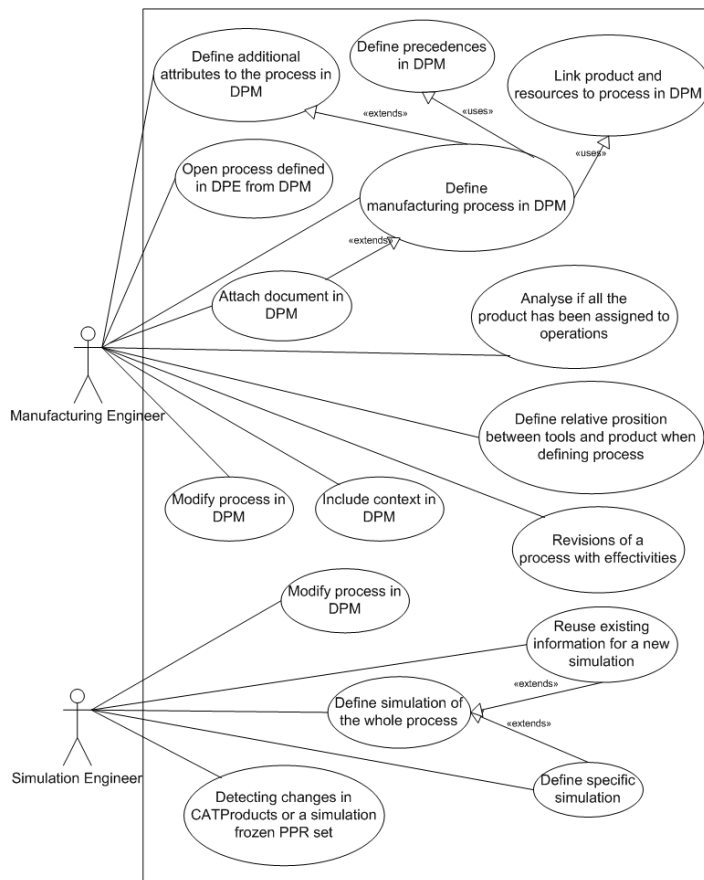

Figure 4. UML Use Case diagram of the project

To succeed in dealing with the above challenges was necessary to have a deep knowledge of the Dassault Systemes PLM tools and to do some research to define the suitable working methods and a deep testing of the developed solutions. Also was evident the need of a sound methodological support in systems development. For that reasons, a multi organization project team was created, where Dassault Systemes is the technical advisor, two

university research groups are in charge of the research work and the methodological support, and two industrial partners are in charge of the development work.

The project was planned in two main phases, a first phase of analysis and definition and a second phase of implementation of the defined solution.

For the systems development methodology it was selected the NDT (Navigational Development Techniques) methodology developed by the IWT2 research group, (García et al, 2012).

In the definition phase, a key activity was to identify and evaluate different alternatives to implement the iDMU Fan Cowl iDMU and to integrate the product structure in it.

Soundly defined Use Cases, as proposed in the NDT methodology, were also a key to deal with the second challenge mentioned above. Figure 4 illustrate the UML Use cases diagram.

4. Results

The selected Dassault Systems technology to implement the iDMU was the PPR Manufacturing Hub(Chen et al 2010). The Manufacturing Hub, based in an ORACLE database, provides a platform in which Process, Product and Resource structures, relations between the three structures and all the associated 3D and technological information can be managed. A Manufacturing Hub was installed and customized for this project and replicated for each partner. A key element of this customization was the data model defined in the analysis and definition phase illustrated in figure 5

To integrate the A320neo Fan Cowl product structure in this platform, a specific interface was developed. The product interface has two modes of operation. One manual mode to import new products from a 3D interactive session and one batch mode to maintain the product structure imported in the Manufacturing Hub synchronized with the mating product structure in the PDM system. The batch mode also checks what product structure nodes has been added, modified or deleted in each pass, and displays this information in the product structure by a colour code. This is useful information for the Process Engineer to know what process may need to be reviewed.

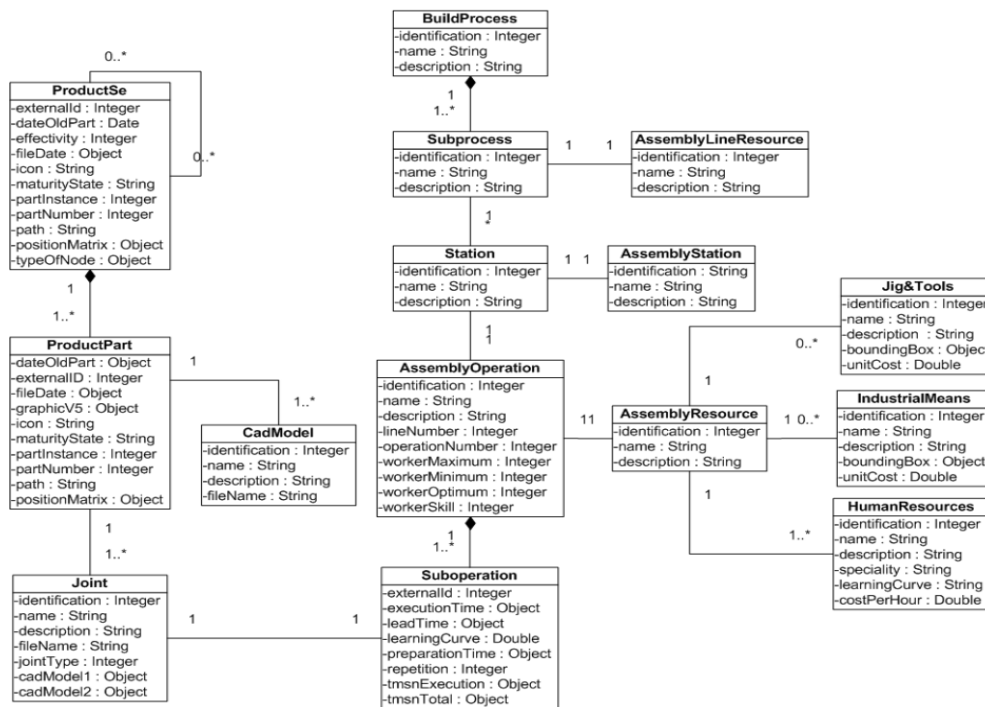

Figure 5. iDMU PPR data model

This product interface can be used also to import the resources structure.

Assembly processes are directly managed in the Manufacturing Hub. It allows creating and updating the assembly processes structure and the data according to the data model. For each assembly operation the product to be mounted and resources needed are linked as defined in the data model. The technical precedence constraints between assembly operations can also be managed in the Manufacturing Hub. A graphical interface allows defining and managing the precedence net as a graph and graph calculations as critical path can be made. A Gantt graph of the assembly operations can also be defined and managed to position the assembly processes in time according the precedence constraints. The Gantt graph of the assembly operations can be made manually or as the output of an optimizing tool.

In this way the iDMU can be populated, processes at each level of the process structure are created, corresponding product and resources are linked to each process and precedence graph and Gantt graph are created for each parent process.

The Manufacturing Hub provides two kinds of user interfaces to navigate and work with the iDMU, one full 3D interface and another one similar to a database interface provided with a light format 3D viewer.

The 3D interface, named DPM (Digital Process for Manufacturing), allows browsing the process structure, selecting a process node and loading it into a 3D DELMIA interactive session with the product and resources associated to the process node. In this 3D interactive session, the process structure under the selected and loaded process can be populated as explained above using all the Digital Manufacturing functionalities provided in DELMIA. Thereby the iDMU is built in a top down process. Regarding the iDMU concept, key features available in the 3D interactive session are the following:

- Product assignment. Using a color code, this feature identifies the nodes of the product structure that are assigned to a process or not.
- Process verification. The processes structure nodes in the 3D session can be “executed” step by step in top down order along the process structure and in the sequence defined in the Gantt graph for each node. At each step, the corresponding state of the product and resources DMU is displayed. That is, for each node, only the product and resources assigned/used in the process executes before are displayed, and the product directly linked to the node is viewed in a different color showing the parts mounted in the corresponding assembly process.
- The 3D interactive session provides the DMU context to make simulations to validate the feasibility and ergonomics of the assembly process selected and loaded.
- The 3D interactive session is also the context for authoring the work instruction of the assembly operation.

The database interface, named DPE (DELMIA Process Engineer) Navigator, allows browsing the three structures showing the attributes and the relations of each node. Nodes and links can be created and updated. The precedence net and the Gantt graph can be displayed and undated also.

Once the assembly operations definition is completed and approved, work instructions for assembly operations can be extracted. DELMIA provides two tools to extract shop floor work instructions from the iDMU: one operates in a DPM 3D session and the other in the DPE Navigator. Both tools had been tested extracting real work instructions. Work instructions can be authored working in the corresponding assembly operation definition in the iDMU. All the assembly operation information, 3D or attributes, can be reused in the corresponding work instruction. In fact, the work instruction preparation with any of these two tools is made by objects associated to the assembly operation and they are part of its process structure.

5. Discussion and Conclusions

This implementation of the A320neo Fan Cowl iDMU and the knowledge derived of working in it confirm the following key facts.

The A320neo Fan Cowl iDMU has provided a single platform, in which all the stakeholders are able to work collaboratively. Functional design engineers, industrial design engineers and tooling engineers have a platform in

which they can share their respective perspectives regarding the iDMU development. Conflicts can be identified and solutions can be negotiated and agreed.

The iDMU is feasible and suitable as the industrial single environment, in which the industrial design of the A320neo Fan Cowl can be design and validated and all the resulting information can be vaulted.

Working in the iDMU as a single environment for industrial design provides the following benefits:

- One single process structure, gathering all the process definition, in which particular processes can be defined and can be easily located. Each node gathers all the corresponding process information including the product and resource DMU context and all the simulations made to validate the corresponding assembly process. Specifically, assembly operations gather also the corresponding work instructions extraction.
- Improved reutilization of the process DMU context for simulations and work instruction creation.
- Improved control of the product evolution and its impact in the assembly processes and tools along its design cycle.
- Improved control of the product evolution and its impact in the assembly operations work instructions along its extraction cycle
- The iDMU is a big enabler for the deployment of Digital Manufacturing and Collaborative Engineering.

Despite the project was focus on a particular case study, the achieved results allows ranking this implementation of the A320neo Fan Cowl iDMU in the most advance maturity level of PLM tools deployment, (IDC Insights White Paper. 2012).

All the above allow concluding that the iDMU concept can be implemented using the DELMIA Manufacturing Hub and such implementation is a big enabler to deploy collaborative engineering supported by Digital Manufacturing tools. It provides a single platform were all product development stakeholders can conduct product functional and industrial design collaboratively and validate the results.

6. Future work

To exploit the iDMU concept to its full potential there are several aspects that need more development.

First of all, the integration of product structure in the iDMU. The product interface implemented in this project is suitable only for a small-medium size aerostructure, but it is not suitable for the size of the product structures needed for FAL (Final Assembly Line) industrialization. Interfaces suitable for any product structure size have to be developed.

To include the complete aircraft lifecycle, the iDMU scope has to be extended to the services function. Services engineers are also stakeholders of the product development and should be able to exploit the iDMU to design services and prepare aircraft service documentation.

The scope of the iDMU has to be extended to include also external enterprise engineering providers. The supply chain is increasingly participating in the product development and also should be able to work collaboratively.

The Manufacturing Hub is a DELMIA V5 tool. It is worth to test how the iDMU can be implemented in a CATIA V6 platform and realize the gains that can be achieved.

Acknowledgements

Authors wish to express their sincere gratitude to colleagues from Airbus Military, Universidad Politecnica de Madrid, Universidad de Sevilla and partners of CALIPSONeo project for their collaboration and contribution to the project.

References

- Butterfield J. et al. 2007. Optimization of aircraft fuselage assembly process using digital manufacturing, *Journal of Computing Inf. Sci. Eng.*, vol. 7, no. 3, pp 269-275.
- Chen D., Kjellberg T., Von Euler A., 2010. Software Tools for the Digital Factory – An evaluation and Discussion, *Proc. of the 6th CIRP Sponsored Intl. Conf. on Digital Enterprise Technology, Advances in Intelligent and Soft Computing*, vol. 66, (2010), pp. 803-812.

- Delpiano M., Fabbri M., Garda C., Valfré E., 2002. Virtual Development and Integration of Advanced Aerospace Systems: Alenia Aeronautics Experience. In: RTO AVT Symposium, Paris, RTO-MP-089.
- García J. A., Alba M., García L., Escalona M^a J., 2012. NDT-Suite: A Model-Based Suite for the Application of NDT, Lecture Notes in Computer Science (The 12th Intl. Conf. on Web Engineering, ICWE).
- IDC Insights White Paper. 2012. Innovación a través de la Colaboración: La situación del PLM en las empresas españolas de fabricación discreta. IDC Manufacturing Insights, octubre 2012.
- Lu S.C-Y., Elmaraghy W., Schuh G., Wilhelm R. 2007. A scientific foundation of collaborative engineering, CIRP Annals - Manufacturing Technology, Volume 56, Issue 2, pp 605-634.
- Mas Morate F., Rios J., Menendez J.L., Hernandez J. C., Vizan A. 2008. Concurrent Conceptual Design of Aerostructure Assembly Lines. Proceedings of 14th International Conference on Concurrent Enterprising, pp 783-790.
- Mas Morate F., Rios J., Menendez J.L., Hernandez J. C., Vizan A. 2009. Information Model for Assembly Line Design at Conceptual Phase. Proceedings of 3rd Manufacturing Engineering Society Int. Conference, pp. 288-295.
- Mas Morate F., Rios J., Menendez J.L. 2012. Conceptual Design of an Aircraft Final Assembly Line: a case study. Key Engineering Materials. Material Science and Engineering, Vol. 502, pp. 49-54.
- Mas Morate F., Rios J., Menendez J.L., Gomez A. 2012. A process-oriented approach to modeling the conceptual design of aircraft assembly lines. International Journal of Advanced Manufacturing Technology, Vol. 62.
- Mas, F, Menendez, J.L., Rios, J. 2013. Collaborative Engineering: an Airbus case study. Submitted to the 5th Manufacturing Engineering Society International Conference, Zaragoza.
- Menendez J. L., Mas Morate F., Servan J., Rios J., 2012. Virtual verification of an aircraft Final Assembly Line industrialization: an industrial case. Key Engineering Materials. Material Science and Engineering. Vol. 502, pp. 139-144.
- Rios J., Mas Morate F., Menendez J.L. 2011. A review of the A400M Final Assembly Line Balancing Methodology. AIP Conf. Proc., 4th Mfg. Eng. Soc. Intl. Conf., MESIC 2011.
- Van Wijk D., et al. 2009. Integrated Design and PLM Applications in Aeronautics Product Development. In: Proc. of the 19th CIRP Design Conf. Competitive Design, Cranfield University.