

Available online at www.sciencedirect.com**SciVerse ScienceDirect**

Procedia Engineering 45 (2012) 584 – 594

**Procedia
Engineering**www.elsevier.com/locate/procedia

2012 International Symposium on Safety Science and Technology Early forest fire detection and verification using optical smoke, gas and microwave sensors

Wolfgang KRÜLL ^{a,*}, Robert TOBERA ^a, Ingolf WILLMS ^a, Helmut ESSEN ^b,
Nora von WAHL ^b

^a University of Duisburg-Essen, Department of Communication Systems, D-47057 Duisburg, Germany

^b Fraunhofer Institute for High Frequency Physics and Radar Techniques FHR, Wachtberg, Germany

Abstract

The research project “International Forest Fire Fighting” (iWBB) was funded by the Minister for Economic Affairs and Energy of the State of North Rhine-Westphalia, Germany. A group of companies, research institutes and universities have been working together to develop an integrated, but modular system. An integrated approach for early forest fire detection and suppression is based on an adequate combination of different detection systems depending on wildfire risk, the size of the area and human presence affiliated with an adequate logistical infrastructure, training by simulation, and innovative extinguishing technology. As in the case of wildfires large areas have to be monitored only remote sensing technologies (e.g. video based systems) are able to perform early detection adequately. To reduce false alarms a remote controlled unmanned aerial vehicle (UAV) equipped with gas sensors and a thermal camera flies to a potential fire to specify the origin of the reported cloud. The UAV can also be used as a scout for fire fighters. After successful fire extinction an unmanned blimp can be used as a fireguard to reduce the risk of re-ignition of the fire. As monitoring tools, a microwave radiometer detecting hot spots also at insufficient vision (due to smoke clouds and below the ground surface), gas and smoke sensors and a thermal camera are mounted on the blimp. The benefit of a blimp is a higher payload. This paper presents an investigation of an early forest fire detection system on the basis of indoor (performed in the fire lab of the University of Duisburg-Essen) and outdoor tests. A commercial highly sensitive aspirating smoke detector, two gas sensors (H_2 and C_xH_x), a microwave radiometer and the detection algorithms are described. A general overview about the project and the carrier platforms is presented.

© 2012 The Authors. Published by Elsevier Ltd. Selection and/or peer-review under responsibility of the Beijing Institute of Technology. Open access under [CC BY-NC-ND license](https://creativecommons.org/licenses/by-nc-nd/4.0/).

Keywords: fire detection; gas sensor; detection algorithm; smoke detector; UAV; microwave radiometer; remote sensing; fire scout; fireguard

1. General outline

Fast and effective detection is a key factor in forest fire fighting. To avoid uncontrollable wide spreading of forest fires it is necessary to detect fires in an early state and to prevent the propagation. It is important to move adequate fire equipment and qualified operational manpower as fast as possible to the source of the fire. Furthermore an adequate logistical infrastructure for sufficient supply with extinguishing devices and maintenance is necessary as well as continuous monitoring of fire spread. Moreover the training of personnel is an important component for successful combating of forest fires. An integrated approach for forest fire detection and suppression is based on a combination of different detection systems depending on wildfire risks, the size of the area and human presence, consisting of all necessary parts such as early detection, remote sensing techniques, logistics, and training by simulation, and fire-fighting vehicles (Fig. 1) [1].

* Corresponding author. Tel.: +49-203-379-3295; fax: +49-203-379-2902.

E-mail address: kruell@nts.uni-due.de

Different risk levels, the size of the area and human presence define the applied sensing techniques. Small high risk areas can be observed by local staff. For very large and low risk areas satellite and aero monitoring is possible. Especially in the eastern part of Germany several hundred observation towers equipped with camera-based systems have been setup to observe forests. Recorded image sequences are transmitted to a control centre and analyzed by appropriate software. If a fire is clearly identified, fire suppression is initialized by an alarm going directly to the fire brigade.

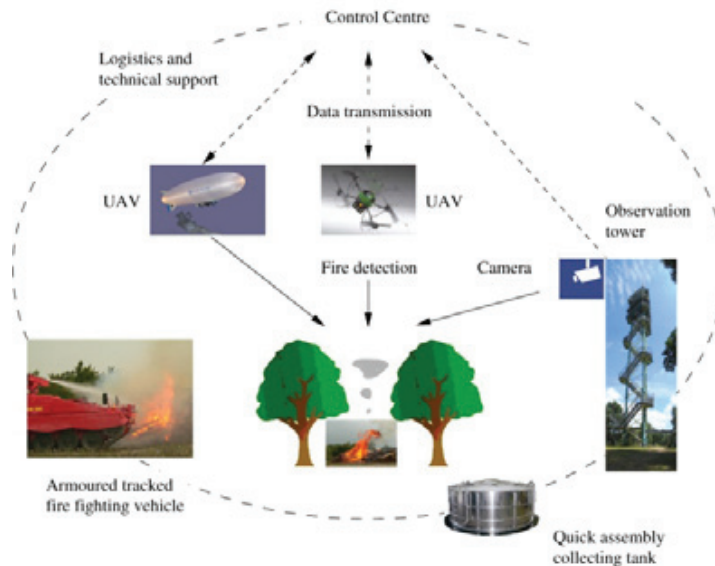

Fig. 1. Schematic structure of the integrated forest fire detection and fire fighting system.

As known from other fire detection technologies the problem of false alarms requires additional measures for alarm verification. Possible false alarms are caused e.g. by dust produced by farmers, pollen, fog, smoke and water plumes produced by power plants, examples are shown in Fig.2. In case of an ambiguous decision a remote controlled Unmanned Aerial Vehicle (UAV) equipped with gas sensors and an infrared camera can fly to the place where a fire is assumed to provide detailed pictures and a multitude of other measured data. Depending on these data a fire will be confirmed or unconfirmed.

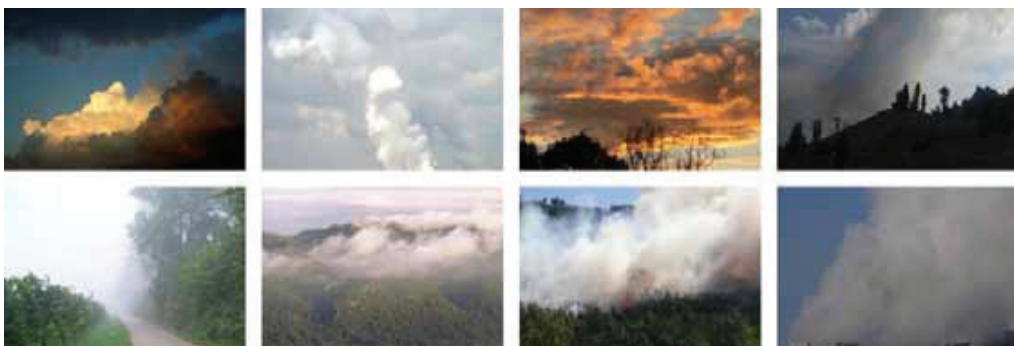

Fig. 2. Scenes with alarm and false alarm situations.

If the source of a fire is not accessible for common fire fighting vehicles with conventional tyres it is only possible to extinguish the fire from the air or by so-called "smoke jumpers". A new solution is a reconstructed armored and tracked fire fighting vehicle as known from military use, supporting existing airborne fire fighting ground-based right at the source of the fire in tough, rugged terrain. An innovative extinguishing system with high-pressure vortex technology was developed to provide a vehicle with extremely low water consumption [2].

2. Carrier platforms for the detection system

A very high reliability of fire detection and a concomitant low false alarm rate can be achieved by the combination of an infrared camera, a microwave radiometer and additional sensors of fire products respectively smoke particles working with conventional and established technologies of fire detection. These detectors should be insensitive to dust and water particles. Depending on the application a selection of these sensors will be mounted on an UAV or a blimp. For both platforms, available space and weight are limited.

2.1. Early forest fire verification with a mini-drone

Carrier platform for the detection system in case of early fire detection is an autonomously flying video drone with excellent navigation skills in every territory. The AirRobot AR100-B (Fig. 3) offers a budget priced alternative to the normal aerial surveillance by a manned helicopter. The UAV enables the fire brigade to have maximum awareness of the situation and the occurrences during their mission. It can either be used for confirmation of an alarm detected by a video system or as well as a scout, helping to find hot spots especially at night while no fire fighting planes are flying.



Fig. 3. AirRobot AR100-B UAV.

The UAV has a diameter of about one meter, a weight of about one kilogram and a silent electric drive (4 brushless- and gearless DC-motors) [3]. Flight time is approx. 25 min depending on the weight of the payload. Maximal speed of the AR100-B is 10 m/s (36 km/h = 5 Bft), maximal wind load is 8 m/s (28.8 km/h = 5 Bft).

It can be flown without any pilot experience. Data transmission and control in real-time is possible by RF devices. The telemetry-data is shown live on the ground station and can be tracked on a map in real-time. The whole processing for obstacle detection and collision avoidance is taking place autonomously in the AirRobot.



Fig. 4. Blimp as a fireguard.

2.2. Hot spot surveillance with a blimp

In the case of monitoring extinguished fires, observation with a radiometer, gas and smoke detectors and a thermal camera attached to a blimp (Fig.4) is performed. Benefit of the 9 meter long airship with 2.3 m diameter is a high payload

of 7 kg including batteries. The embedded-PC controls the blimp as well as the communication and data transfer to the ground station as shown in Fig. 5.

The ground station consists of a user interface (Comm-PC) to transmit and receive flight data from the blimp via WLAN. Users (in this project Uni-DuE, FHR) have to request their sensor data via TCP/IP at the ground station. The received data are combined with GPS data of the blimp and a time stamp for visualization and are fed into the detection algorithms, determining whether an alarm has to be executed or not.

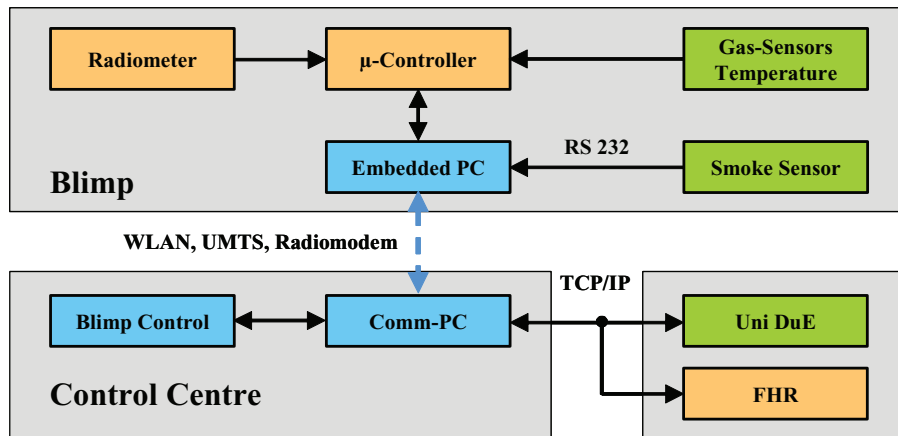

Fig. 5. Communication structure for the blimp.

3. Early fire detection with gas sensors and smoke detectors

The sensor system is used to verify an ambiguous situation detected by a video-based system as well as observing an extinguished fire. Therefore sensors have to be widely immune against disturbances like steam, fog, dust pollution and condensing water which usually cause video-based systems to give false alarms.

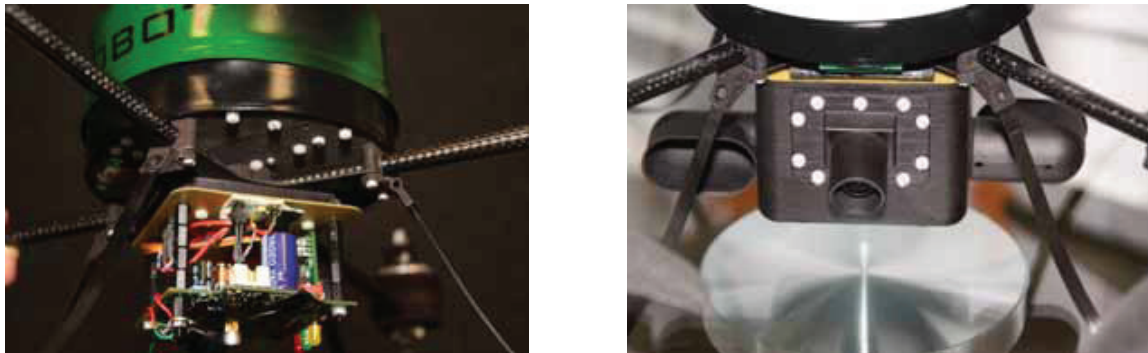

Fig. 6. AirRobot UAV with gas sensors and a camera.

If fire gases are carried to the detector by the airflow they are analysed with different semiconductor gas sensors. A gas-permeable protective cap made of sintered metal protects the sensor elements against soiling with dust and humidity. Thus the sensor array is not affected by nuisance aerosols like dust, dirt, mist or condensing water [4].

Early forest fire detection sensors (Fig. 6) have to fulfil a lot of specific requirements compared to conventional applications. High sensitivity is needed to detect even low smoke concentration; dilution and extreme turbulence caused by wind are essential factors. Due to high occurrence of hydrogen during an open fire a H_2 -Sensor [0 – 10ppm] was implemented[5,6]. Main features of this semiconductor gas sensor (GTE GSME) are a very fast response time and a high sensitivity [4]. A C_xH_x -Sensor [0 – 5ppm] is used because hydrocarbon sensors are sensitive to organic fire products. Fast temperature fluctuations are measured by a temperature sensor.

Additionally a highly sensitive aspirating system (Hekatron ASD535 [7]) is used for smoke detection in case of observing an extinguished fire with a blimp. Thus it is possible to discriminate between the gas emission of an extinguished

fire and even low smoke concentrations of a blazing fire. In addition to these sensors the blimp is equipped with a microwave radiometer and a camera. The structure of the implemented detection system is shown in Fig. 7.

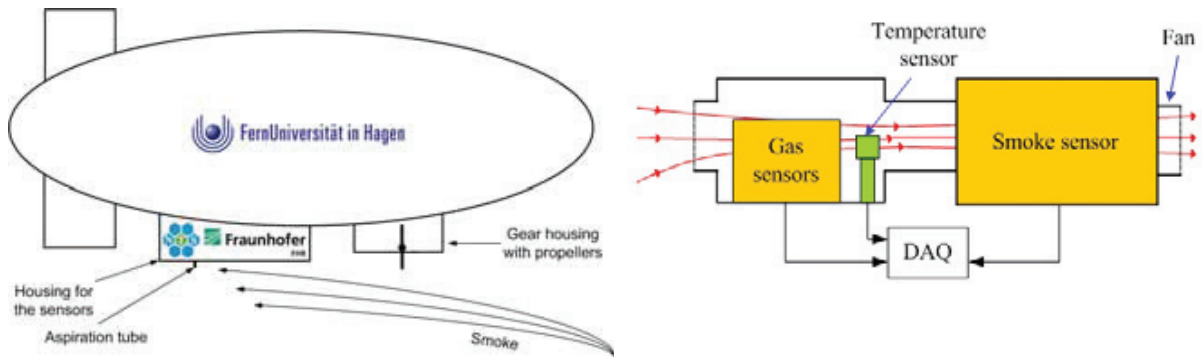

Fig. 7. Structure of the sensor system and the internal airflow.

4. Detection algorithm for gas and smoke detection

The difference to conventional installations in industrial premises or in private houses is the dilution and an extreme turbulence caused by wind. The sensors have to be sensitive enough to detect even very low smoke concentrations. For this reason gas sensors or a combination of gas sensors together with an aspiration system are used. But this application requires a different way of testing during the development of the algorithm, compared to the standardized test methods for smoke detectors installed in buildings. To achieve the aim to detect forest fires in a very early state it is essential to understand the ignition phase of a forest fire. Three phases of fire development are shown in table 1.

Table 1. Three phases of fire development

Ignition / pyrolysis phase	Invisible smoke aerosols Fire gases	Detection range of gas sensors and aspirating systems
Smoldering fire	Visible smoke aerosols	Detection range of gas sensors and optical smoke detectors
Open fire	Heavy smoke and heat development	Detection range of optical smoke detectors

The response behavior of a lot of species was analyzed in the Duisburg Fire Lab by performing smoldering fires (ignited by a hotplate) and small open fires (ignited by ethyl alcohol). Straw, hay, oven-dried leaves, pine needles and small branches were used as fuel. It was shown that there is a big difference e.g. between dead pine needles and live needles. Pine needles are representative for Mediterranean regions, dead needles will ignite and burn faster with a higher intensity for example and cause different values for gas and smoke concentration. The tests in the Duisburg Fire Detection Laboratory showed the benefit of a combination of semiconductor gas sensors and an aspirating system. It is possible to detect fires in the pyrolysis phase of the fire as well as in the smoldering stage [8]. Tests have shown that turbulences caused by the rotors of the UAV have nearly no influence on the gas sensors and the aspiration system.

$$S_{\text{gas},T} = [(N_{\text{H}_2,\text{filtered}} K_{\text{H}_2} + N_{\text{CH},\text{filtered}} K_{\text{CH}}) (1 + N_{\text{T},\text{filtered}} K_{\text{T}})] \quad (1)$$

$$S_{\text{gas},T} \geq \text{Alarm threshold} \Leftrightarrow \text{Alarm} \quad (2)$$

With the analysis of sensor data measured by the AirRobot drone a pre-alarm of a video-based system shall be confirmed or unconfirmed. The measured sensor signals for hydrogen (N_{H_2}), hydrocarbon (N_{CH}) concentration and temperature (N_{T}) are transmitted to the control centre and are fed into the detection algorithm (Fig. 8), according to eq. 1 and eq. 2. The decision “alarm / no alarm” is the result of the output value $S_{\text{gas},T}$ compared to the alarm threshold. Due to the application and the limited payload of the UAV a smoke detector is not implemented.

The algorithm can be adapted to the environmental conditions by subtraction of the sensors’ quiescent values; just variations will cause an alarm. Pulseforming is necessary because of different response characteristics of the sensors. Especially in situations with high turbulences with very short smoke and gas pulses it is helpful. The third part of the algorithm is weighting and fusion of the pre-processed sensor signals.

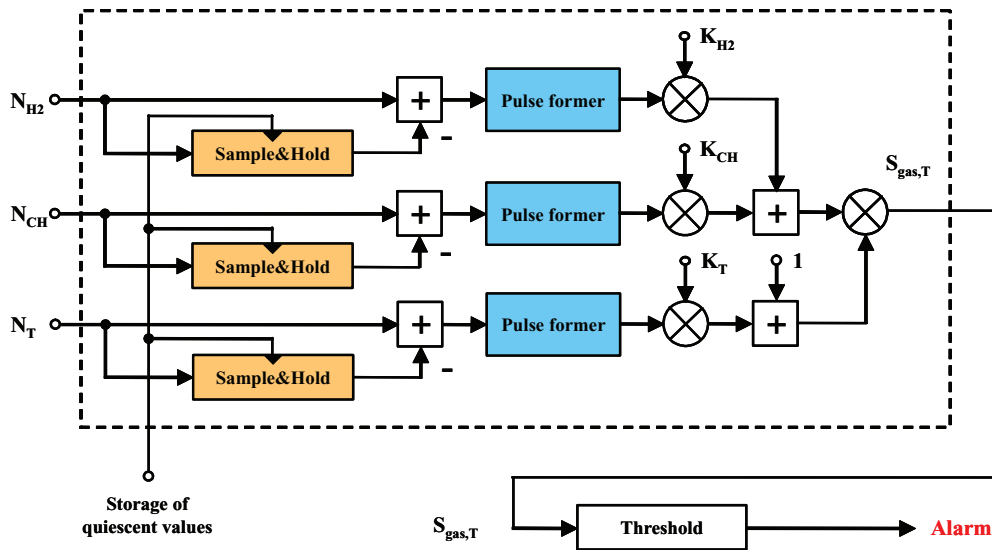

Fig. 8. Structure of the detection algorithm for the AirRobot application.

The observation of extinguished areas is performed by a blimp in order to detect buried hotspots and reignited seats of fire. This application requires an additional smoke detector and the detection algorithm has to be modified, according to eq. 3 and eq. 4. The measured sensor signals for smoke density (N_D), hydrogen (N_{H_2}), hydrocarbon (N_{CH}) and temperature (N_T) are transmitted from the blimp to the control centre. Fig. 9 shows the structure of the implemented detection algorithm. The gas production of open and smouldering fires is different. Due to the chosen weight (K_{H_2} und K_{CH}) of the gas sensor signals the susceptibility of the algorithm to both types of fires is similar. The algorithm also takes care of the temperature and the light scattering measurements.

$$S_{gas,T,D} = S_{gas,T} (N_{D,filtered} K_D) \tag{3}$$

$$S_{gas,T,D} \geq \text{Alarm threshold} \Rightarrow \text{Alarm} \tag{4}$$

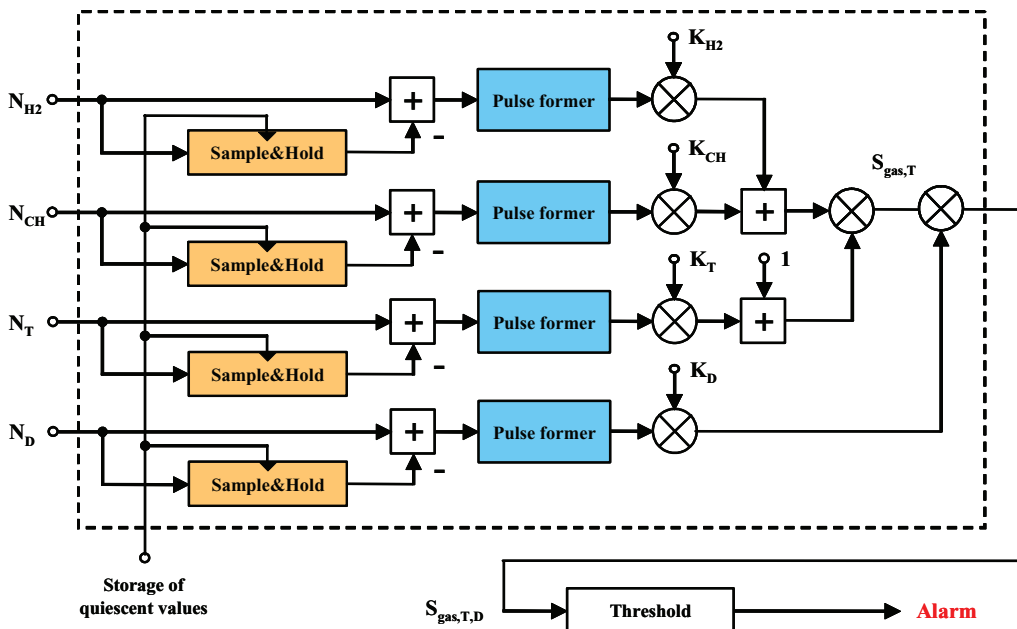

Fig. 9. Structure of the detection algorithm for the blimp application.

The gas production of open and smouldering fires is different. Due to the chosen weight (K_{H_2} and K_{C_H}) of the gas sensor signals the susceptibility of the algorithm to both types of fires is similar. The algorithm also takes care of the temperature and the light scattering measurements.

5. Outdoor measurements

The main focus is the early smoke detection of wildfires in order to reduce the damaged area to a minimum. Large and high-intensity forest fires are widely uncontrollable and cause very high risk. To reduce false alarms, especially in hardly accessible terrain such as a forest fire in the mountains, a remote controlled UAV can fly to the place where a fire is assumed to confirm that the origin of the smoke is most likely a fire. Fig. 10 and Fig. 11 show gas sensor and temperature data measured during flight tests with the AirRobot drone as well as the alarm signal $S_{gas,T}$. The detection algorithm and the alarm threshold were adapted to the situation.

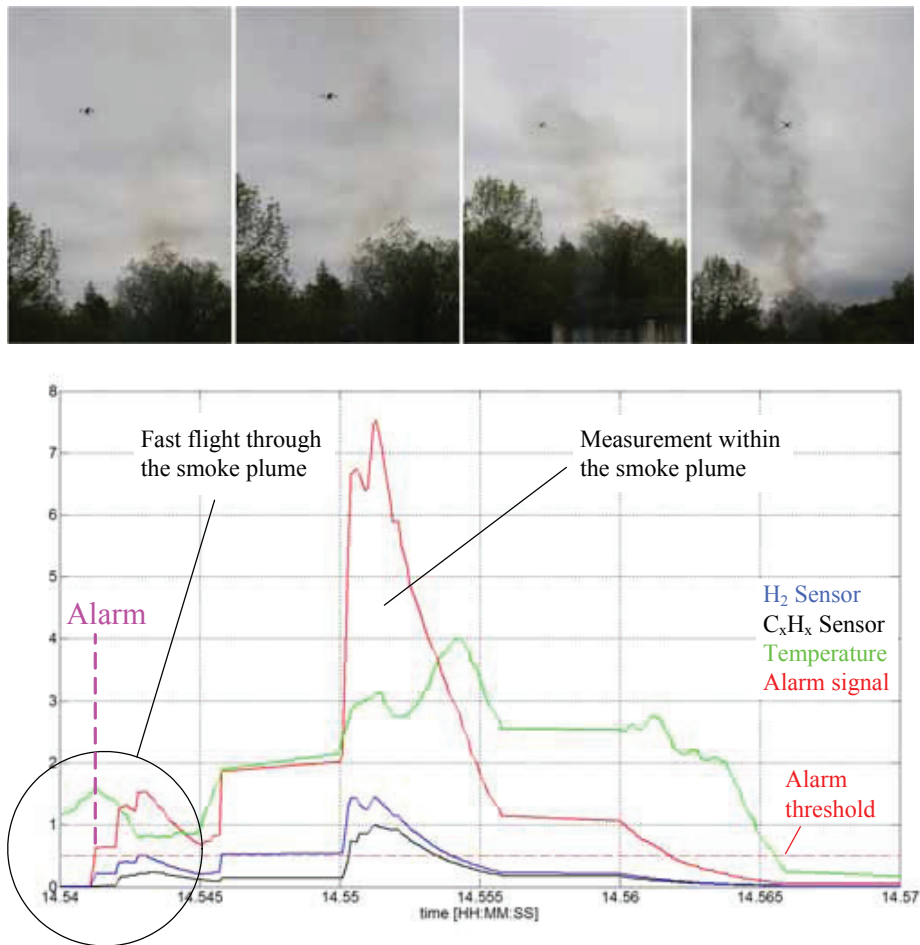

Fig. 10. Gas sensor and temperature data measured during flight tests with the AirRobot drone.

Even very low gas concentrations in case of a fast flight through the smoke plume can be detected and the pre-alarm caused by a video-based system can be confirmed. Flight height during the test was about 15 m. Data in Fig. 10 show that it is possible to measure within the smoke plume to find the centre of the fire.

In case of observing an extinguished area with a blimp the additional aspiration detector provides a reliable discrimination between gas emission of e.g. extinguished trees and reignited seats of fire. Fig. 12 shows gas, smoke and temperature data measured in case of a fast flight through the smoke plume as well as the alarm signal $S_{gas,T,D}$.

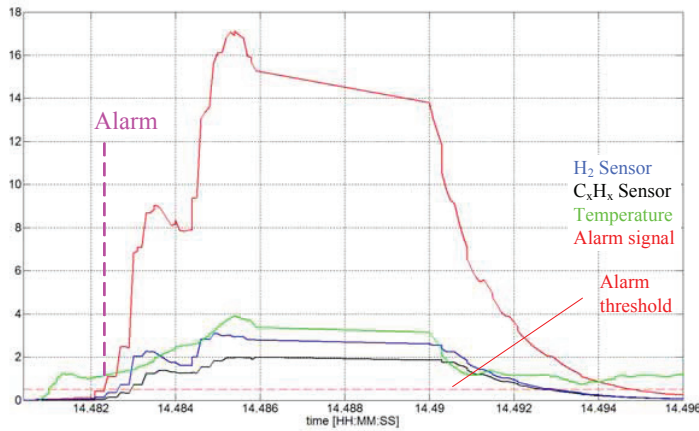

Fig. 11. Gas sensor and temperature data measured during flight tests within a smoke plume.

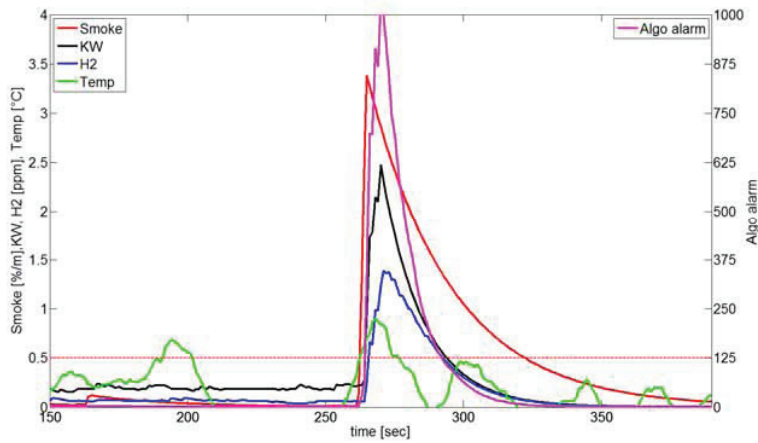

Fig. 12. Gas and smoke sensor data measured during flight tests with the blimp.

After the detection of smoke and gases a hot spot normalization is necessary. The implemented microwave radiometer allows the vision even through dense smoke.

6. Microwave radiometer

The proposed microwave radiometer detects fire radiation at 22.3 GHz. According to Planck's law a black body reaches its maximum of the radiation power in the infrared region. With the assumption that fire has similar characteristics as a black body, the wide use of conventional IR-cameras in fire detection applications is reasonable. In [9] it was shown that fire detection is also possible with microwave sensors. Additionally, good transmission normalization in smoke, dust and fog is typical for sensors working in the lower GHz region [10]. Background is the long wavelength which leads to less absorption and scattering for particles of the materials with lower diameters compared to infrared light. This characteristic of microwaves can be exploited for hot spot detection in smoke-filled environments. Furthermore, after extinguishing of a forest fire, often hot spots occur and propagate under the upper surface of the earth. That leads very often to re-ignition of forest fires. A microwave radiometer allows detection of hot spots even if the fire is covered by thin layers of leaves, scrub

and the like. In case of observing an extinguished fire with a blimp a microwave radiometer is a reasonable extension to the gas sensors and the smoke detector.

Fig. 13 presents the principle of the radiometer. Via a switch a signal is alternately received from the scene of interest (through a planar group antenna) and a noise source which can be exploited for signal normalization. In the following processing the signal gets amplified and filtered. To prevent disturbances of the radiometric signal by other systems, the frequency of the radiometer was adapted to a radio-astronomical band with a bandwidth of 600 MHz.

$$\alpha = 72 \frac{c_0}{f \times d} \tag{5}$$

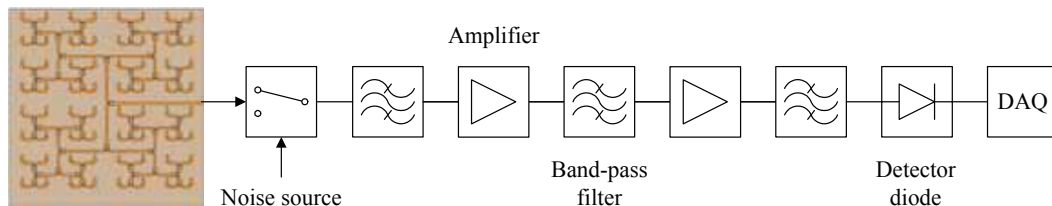

Fig. 13. Block diagram of the microwave radiometer.

The image resolution of the radiometer depends on the antenna opening angle and the flying altitude and follows basic trigonometric rules. The antenna opening angle can be calculated (eq. 5) from frequency f , antenna size d , and the speed of light in a vacuum c_0 .

The radiation from a square cell of 2.6 m edge length, the so called footprint of the system, can be detected with a 22.3 GHz radiometer, a flying altitude of 30 m, an antenna size of 20 cm and an opening angle of approx. 5°. The detection probability of a fire is highest if the footprint compares to the area of the fire. With the radiometer described above, only one pixel is generated. To produce several pixels, more than one antenna, a scanning system or a systematic flying platform has to be implemented.

Fig. 14 shows the radiometer together with a temperature sensor, processing boards and the DAQ. The size of the radiometer is 105 mm x 150 mm x 73 mm and the weight including the case (300 g) is approximately 800 g. Further reductions are possible by designing chip based high frequency components and merging all single boards. To increase the field of view the patch antenna is attached to a small video camera with vertical and horizontal scan axis, Fig. 15. Due to the fact that both sensors get data from the same direction, these data can be superimposed.

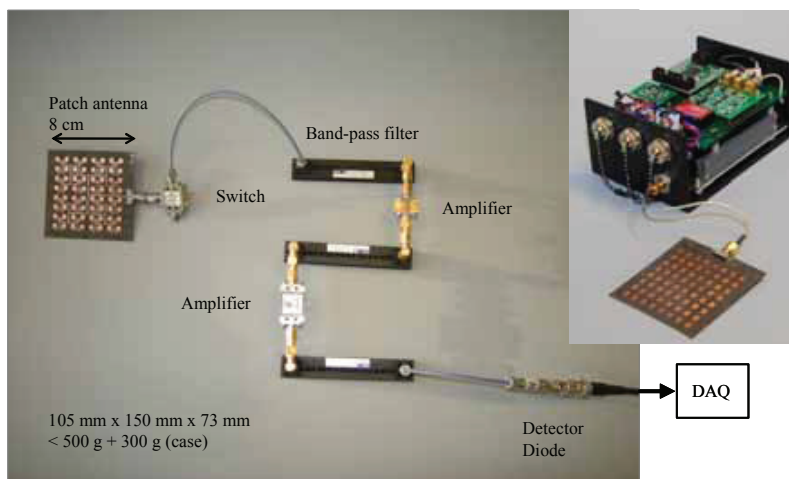

Fig. 14. Image of the 22.3 GHz radiometer.

The results of a 2D scanning radiometer and the good fire detection by microwave radiation through a small tree are shown in Fig. 16. The radiometer was placed on a turntable to receive 2D images. The image shows a scan of a tree, the

radiation of a charcoal fire, and the tree in front of the fire. It can be seen that the microwave radiation of the charcoal fire is attenuated by the tree but that it can still be clearly identified.

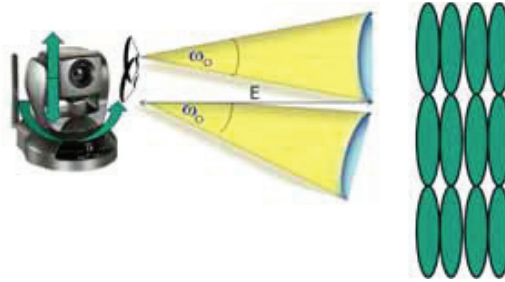

Fig. 15. Scanning mechanism and illustration of footprints on the ground at distance E.

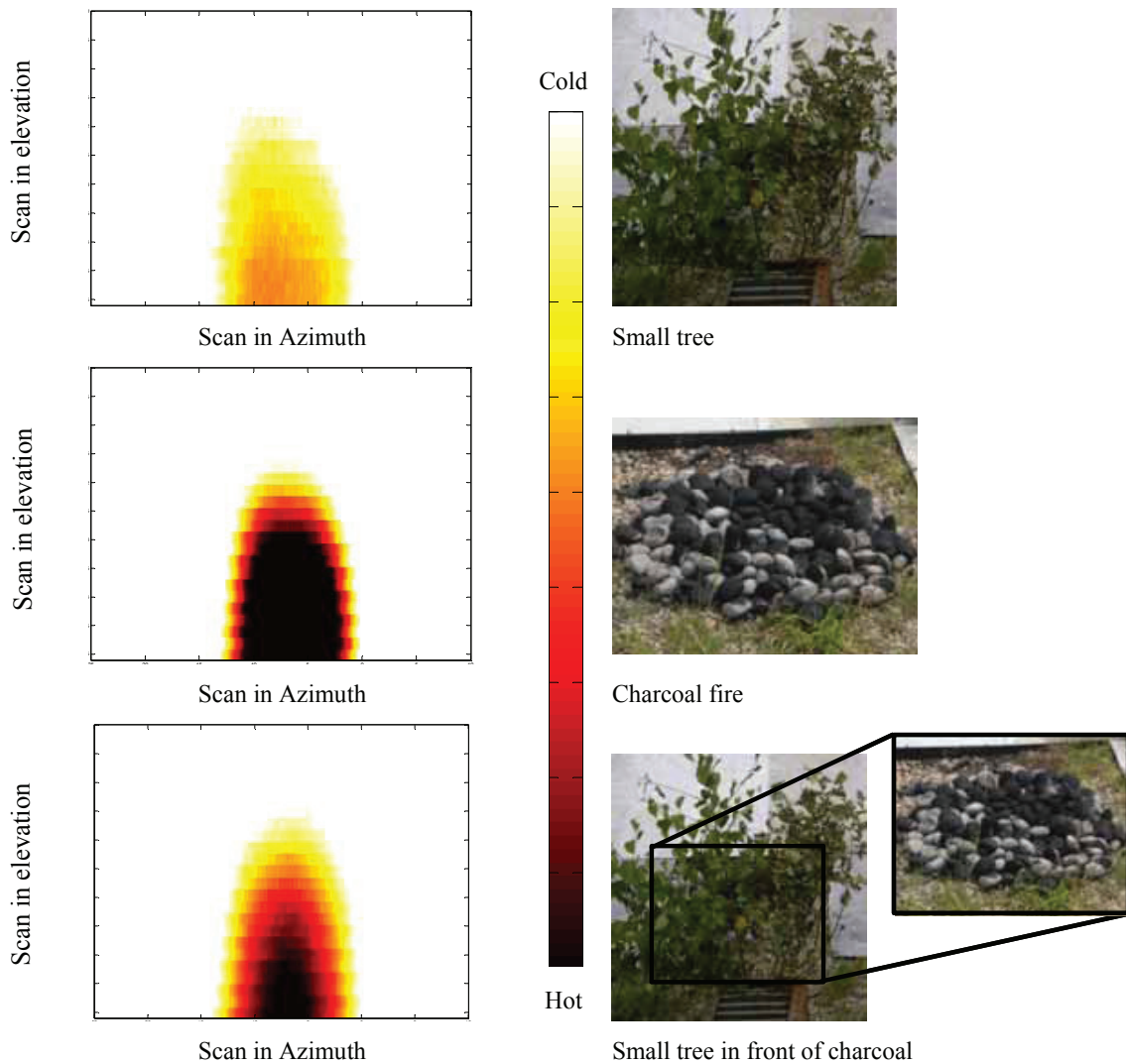

Fig. 16. Radiometric measurement results: tree alone, charcoal alone, tree in front of charcoal fire.

7. Outlook

A good interrelation of a very early and reliable smoke detection of forest fires, remote sensing techniques, logistics and technical support, training of fire fighters by simulation and an adequate extinguishing and rescue system will reduce damage and smoke impact on humans. The main focus has to be on early smoke detection because large and high-intensity forest fires are widely uncontrollable and cause very high risks.

To reduce false alarms of video-based systems, especially in hardly accessible terrain, a remote controlled UAV can fly to the place where a fire is assumed to confirm that the origin of the smoke is most likely a fire. The UAV is equipped with semiconductor gas sensors because of high immunity against disturbances like steam, fog, dust pollution and condensing water. Thus, a good discrimination between alarm and false alarm is possible.

After extinguishing forest fires or wildfires a blimp can work as a fireguard. Due to the blimps higher payload semiconductor gas sensors are used together with an aspirating smoke detection system. In this application it is possible to detect even lowest smoke and gas concentrations to confirm an alarm under laboratory conditions as well as under outdoor conditions. The 22.3 GHz radiometer is able to detect fire even under insufficient vision due to smoke emissions, dust or fog. Materials as leaves and thin walls can be partly penetrated by the microwave radiation. The current design can be further miniaturized using chip-based components.

References

- [1] von Wahl, N., Heinen, S., Tobera, R., Nüßler, D., Brauns, R., Schröder, M., Knott, P., Krüll, W., and Willms, I., 2009. Intermediate Report Internationale Waldbrandbekämpfung iWBB, FHR-Report Nr. 134, FGAN Research Institute for High Frequency Physics and Radar Techniques, Wachtberg, Germany.
- [2] Henrichs, M., 2009. Armored and Tracked Vehicle for Rescue/Extinguish/Defend Missions, 14th International Conference on Automatic Fire Detection, AUBE '09, Duisburg, Germany.
- [3] AirRobot GmbH & Co. KG, <http://www.airrobot.de>
- [4] GTE Industrieelektronik GmbH, <http://www.adicos.de>
- [5] Krüll, W., Willms, I., Tobera, R., and Wiggerich, B., 2009. Early forest fire detection and suppression - an integrated approach, 14th International Conference on Automatic Fire Detection, AUBE '09, Duisburg, Germany.
- [6] Tobera, R., Krüll, W., and Willms, I., 2009. Optical smoke and gas sensors as an additional method for early wildfire verification, 14th International Conference on Automatic Fire Detection, AUBE '09, Duisburg, Germany.
- [7] Hekatron Vertriebs GmbH, <http://www.hekatron.de>
- [8] Krüll, W., Tobera, R., Willms, I., von Wahl, N., Heinen, S., 2008. An integrated approach for early forest fire detection and suppression, First International Conference on Remote Sensing Techniques in Disaster Management and Emergency Response in the Mediterranean Region, Zadar, Croatia.
- [9] von Wahl, N., Heinen, S., 2009. Advantages of millimeter waves in fire detection and monitoring, 14th International Conference on Automatic Fire Detection, AUBE '09, Duisburg, Germany.
- [10] Nüßler, D., Essen, H., von Wahl, N., Zimmermann, R. Rötzel, S., and Willms, I., 2008. Millimeter Wave Propagation through dust, SPIE conference proceedings.