



ELSEVIER



CrossMark

Available online at www.sciencedirect.com**ScienceDirect**

Procedia Engineering 97 (2014) 1948 – 1956

**Procedia
Engineering**www.elsevier.com/locate/procedia

12th GLOBAL CONGRESS ON MANUFACTURING AND MANAGEMENT, GCMM 2014

A Fuzzy Logic based Model to predict the improvement in surface roughness in Magnetic Field Assisted Abrasive Finishing

T.C. Kanish^a*, P. Kuppan^b, S. Narayanan^c, S. Denis Ashok^d^a Assistant Professor(SG), SMBS, VIT University, Vellore- 632014, TamilNadu, India^{b,d} Professor, SMBS, VIT University, Vellore- 632014, TamilNadu, India^c Senior Professor, SMBS, VIT University, Vellore- 632014, TamilNadu, India

Abstract

In this paper the effect of process parameters during Magnetic Field Assisted Abrasive Micro Finishing (MFAAF) of SS316L material is reported. Based on the experimental results obtained, S/N ratio and ANOVA analyses were made to identify the significant process parameters to improve the percentage improvement of surface roughness (% Δ Ra). From the results it is observed that the process parameters like voltage applied to the electromagnet, machining gap, rotational speed of electromagnet followed by abrasive size are significant to improve the % Δ Ra. Based on the process parameters selected from the S/N ratio analysis and ANOVA analysis, a fuzzy logic model has been developed to predict the % Δ Ra. To develop the fuzzy model, four membership functions based on the four process parameters are assigned to be connected with each input of the model. The developed fuzzy model is tested using three different set of process parameters values that are not used in already existing experimental data set. It is found that the developed fuzzy model has a close relation with the experimental values with the maximum deviations of 7.16%.

© 2014 Published by Elsevier Ltd. This is an open access article under the CC BY-NC-ND license

[\(http://creativecommons.org/licenses/by-nc-nd/3.0/\)](http://creativecommons.org/licenses/by-nc-nd/3.0/).

Selection and peer-review under responsibility of the Organizing Committee of GCMM 2014

1. Introduction

Traditional finishing processes like grinding, lapping and honing employ a rigid tool that subjects the workpiece to substantial normal stresses which may cause micro-cracks resulting in reduced strength and reliability of the machined part[1]. So, Traditional finishing processes alone are incapable of producing required surface finish[2]. This led to the development of newer non traditional finishing process like Magnetic Field Assisted Abrasive Finishing (MFAAF). This process employs the magnetic force and magnetic abrasives for finishing a variety of engineering materials. The MFAAF process removes tiny amount of material by indentation and rotation of magnetic abrasive particles (MAPs)[3]. The MAPs are consisting of iron particles and abrasive powder which is

* Corresponding author. Tel.: 9894141493

E-mail address: tkanish@vit.ac.in

filled in the gap between the workpiece and the electromagnet. The MAPs join with each other along the lines of magnetic force and form a Magnetic Abrasive Flexible Brush (MAFB) between the workpiece and the electro magnet. Magnetic force plays a dominant role in the formation of MAFB and developing abrasion pressure. This MAFB behaves like a multi-point cutting tool while rotating the magnet [4]. The basic principle of the MFAAF process for finishing of flat surfaces were studied by Shinmura et al. [5,6] on difficult-to-machine materials. Further many researchers have investigated to improve the MFAAF process by investigating characteristics of abrasive behavior[7], forces acting during MFAAF[8] and surface texture generated for finishing of flat surfaces[9]. Jain et. al[10] studied the effect of working gap and circumferential speed on the performance of magnetic abrasive finishing process. Singh et al. [11] investigated the parametric study of Magnetic Abrasive finishing process to improve change in surface roughness. Mori et al. [12] clarified the mechanism of abrasive finishing for the non magnetic material. Kremen et al. [13] investigated the machining time required to achieve specified accuracy of the workpiece. Yang et al. [14] demonstrated the magnetic abrasive finishing of stainless steel work material using a permanent magnet. On the other hand, many researchers started to develop the mathematical modeling of MFAAF process [1,15]. Mulik and Pandey[16] developed a Response Surface Methodology (RSM) along with second order polynomial model to predict ΔRa based on variation of voltage, mesh number, rotary speed and weight percentage of abrasive particle. Recently, Lee et al. [17] developed sensor based approaches coupled with artificial neural network to correlate relationship between data obtained by force and acoustic emission signal to surface roughness. Teimouri et al. [18] developed a Feed Forward Back-Propagation Neural Network (FFBP-NN) and Adaptive Neuro-Fuzzy Inference System (ANFIS) to predict the performance of magnetic abrasive finishing process.

From the literature survey, it is observed that most of the researchers used to predict the change in surface roughness by using linear models[11], RSM based models[16], artificial evolutionary approaches[18] like Artificial Neural network models and neuro-fuzzy inference system to produce smoother surface in MFAAF process. From the literature, it is found that very few researches are carried out in MFAAF process using fuzzy inference system. So, in this study a fuzzy logic model has been developed to predict the percentage improvement in surface finish. The developed fuzzy logic model is used for analyzing the effect of process parameters and it is explained using the three dimensional surface plots. The S/N ratio and ANOVA analyses were made to find the significant process parameters. These analyses are also used to validate the experimental results before developing the fuzzy logic model.

2. Experimentation

In the present work, an experimental set-up was developed for carrying out the MFAAF process in a precision CNC vertical milling machine. The experimental setup consists of an electro magnet, mandrel, sleeve, lock-nut and power supply for electromagnet. Fig.1 shows the schematic view of experimental setup.

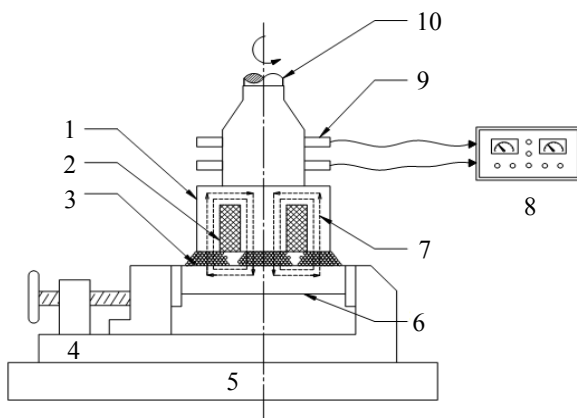

Fig. 1 Schematic view of MFAAF setup

Item No	Item Name
1	Electro Magnet
2	Coil
3	MFAFB
4	Machine Vice
5	Machining Table
6	Workpiece
7	Magnetic Flux(Φ)
8	Power Supply
9	Slip Rings
10	Machine spindle

The work material selected for this study is austenitic stainless steel 316L grade material, due to its wide applications in medical field to manufacture the medical implants and orthopaedic implants. The MAPs consisting of ferromagnetic particles and Silicon carbide (SiC) abrasive particles by 80:20 ratios (by weight percentages) are used in the study. The experiments were planned using Taguchi's design of experiments method. The process parameters selected and their levels are shown in Table 1. For the four selected parameters and three levels, the most suitable Taguchi L⁹ orthogonal array is selected for the experiments (Table 2). The other parameters such as machining time (30 min.) and feed (35 mm/min) are kept constant.

Table 1. Process parameters selected and their levels

Notation	Process parameters	Unit	Levels		
			1	2	3
A	Voltage	V	15	17.5	20
B	Machining gap	mm	1.5	1.75	2.0
C	Rotational speed of electromagnet	rpm	270	405	540
D	Abrasive size	mesh	400	800	1200

The average surface roughness values (Ra) of the workpiece material were measured before and after the MFAAF process using Mahr surfest equipment. The final surface roughness value was measured at the same points (using the template) where initial roughness values were measured initially. The percentage improvement in surface finish (%ΔRa) values have been calculated using the Eq. 1, and the calculated values for each experiment are tabulated in Table 2. An example of measured surface roughness at the condition is shown in fig 2.

$$\% \Delta R_a = \frac{\text{Initial } R_a \text{ value} - \text{Final } R_a \text{ Value}}{\text{Initial } R_a \text{ Value}} \times 100 \quad (1)$$

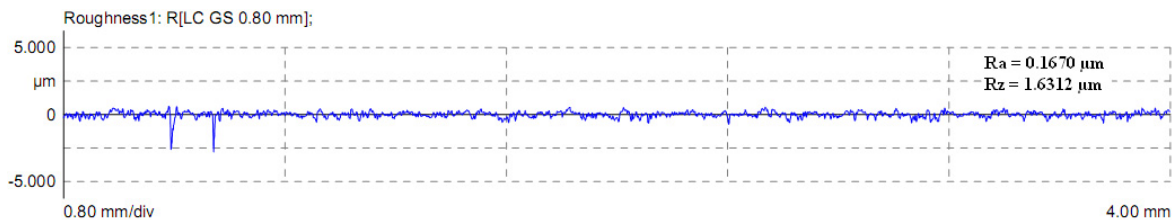

Fig 2. An example of measured surface roughness at the condition of A3, B3, C2, D1

3. Results and Discussion

3.1. S/N ratio analysis

S/N ratio is the ratio of signal to noise where signal represents the desirable values (i.e., mean for the output characteristic), and noise represents the undesirable value (i.e. the square deviation for the output characteristic). For the present investigation, “Larger is better” quality characteristic is chosen since higher percentage improvement in surface finish is desirable. Calculated S/N ratios for all experiments are listed in Table 2. The mean of S/N ratios for the process parameters on %ΔRa is shown in Fig 3. The high level of surface finish of the work material is achieved at higher signal to noise ratio. From the response of signal to noise ratio shown in Table 3, it is found that the percentage improvement of surface roughness is significantly influenced by the voltage(A3) applied to the electromagnet, machining gap(B1), Rotational speed of the electro magnet(C3) followed by Abrasive size(D3).

Table 2. %ΔRa and S/N ratio values

S.No	A (V)	B (mm)	C (rpm)	D (mesh)	%ΔRa	S/N Ratio (dB)
1	15.0	1.50	270	400	41.51	32.3631
2	15.0	1.75	405	800	35.12	30.9111
3	15.0	2.00	540	1200	38.31	31.6662
4	17.5	1.50	405	1200	70.24	36.9317
5	17.5	1.75	540	400	47.89	33.6049
6	17.5	2.00	270	800	35.12	30.9111
7	20.0	1.50	540	800	79.82	38.0422
8	20.0	1.75	270	1200	63.86	36.1046
9	20.0	2.00	405	400	51.09	34.1667

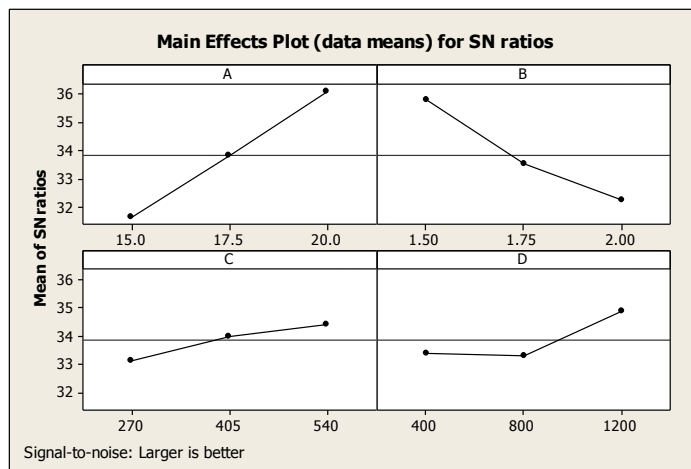

Fig. 3 Main effect plot for %Δ Ra signal to noise ratio

Table 3. Response Table for Signal to Noise Ratios

Level	A	B	C	D
1	31.65	35.78	33.13	33.29
2	33.82	33.54	34.00	33.38
3	36.10	32.25	34.44	34.90
Delta	4.46	3.53	1.31	1.61
Rank	1	2	4	3

3.2. Analysis of Variance (ANOVA)

The significant parameters influencing the surface roughness are determined by using the Analysis of Variance (ANOVA). The ANOVA results for %ΔRa are shown in Table 4. From the ANOVA results, it is found that the surface roughness is significantly influenced by the voltage(A3) applied to the electromagnet, machining gap (B1) and rotational speed of electromagnet (C3) followed by abrasive size(D3). This ANOVA result confirms with the result obtained by S/N ratio analysis.

Table 4. ANOVA results for %ΔRa

Source	DOF	SS	MS	F-ratio	P-value	(%) Contribution
A	2	2077.65	1038.83	310.44	0.000	46.35
B	2	1780.83	890.42	266.09	0.000	39.73
C	2	188.79	94.39	28.21	0.000	4.21
D	2	405.44	202.72	60.58	0.000	9.04
Error	9	30.12	3.35			0.67
Total	17	4482.84				

4. Fuzzy logic based model to predict the improvement in surface roughness:

In 1965, Zadeh [19] introduced the fuzzy set theory. Fuzzy logic is a mathematical theory of inexact reasoning that allows modelling of the reasoning process in human linguistic terms such as medium, slow, and fast, may be defined by fuzzy sets. Since its introduction, fuzzy set theory has attracted the attention of many researchers in the mathematical and engineering fields. In this work, The relation between the input process parameters which are Voltage(A) applied to the electromagnet, Machining gap(B), Rotational speed of the electro magnet(C) followed by Abrasive size(D) with the output parameter which is percentage improvement in surface roughness (%ΔRa) were referred to construct the fuzzy inference system, shown in Fig 4.

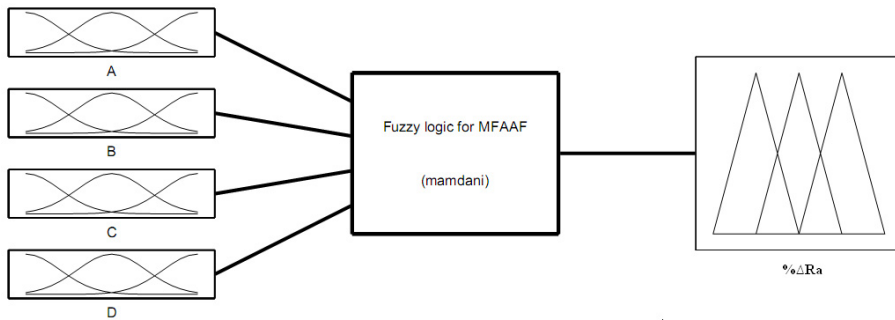

Fig 4. Overview of Fuzzy inference system

Fuzzy linguistic variables and fuzzy expressions for input and output process parameters were shown in Table 4. For each input variable, three membership functions were used which are low, medium and high. The output variable, percentage improvement in surface roughness (%ΔRa) also used three membership functions namely good, better and best. The corresponding fuzzy linguistic variables for each process parameters are shown in Table 5.

Table 5. Fuzzy linguistic variables for each input and output process parameters

Inputs				
Notation	Process parameters	Units	Linguistic variables	Range
A	Voltage	V	Low (L), Medium (M), High (H)	15 - 20
B	Machining gap	mm		1.5 - 20
C	Rotational speed	rpm		270 -540
D	Abrasive size	mesh		400 – 1200
Output				
%ΔRa	Improvement in surface finish	%	Good, Better, Best	35.12 – 79.82

4.1. Membership functions:

A membership function (MF) is a curve that defines how each point in the input space is mapped to a membership value (or degree of membership) between 0 and 1. In this fuzzy model, each input and output process parameters has three membership functions. For input process parameters gauss shape of membership function is employed to describe the fuzzy sets to achieve smoothness in the membership functions. In output variables fuzzy set, triangular shape of membership functions are used due to its gradually increasing and decreasing characteristics. According to the experiment parameter ranges the input process parameters have been divided and the created membership functions for the fuzzy input variables are depicted in Fig 5. Corresponding Membership function for the output variable percentage improvement in surface roughness is shown in Fig 6.

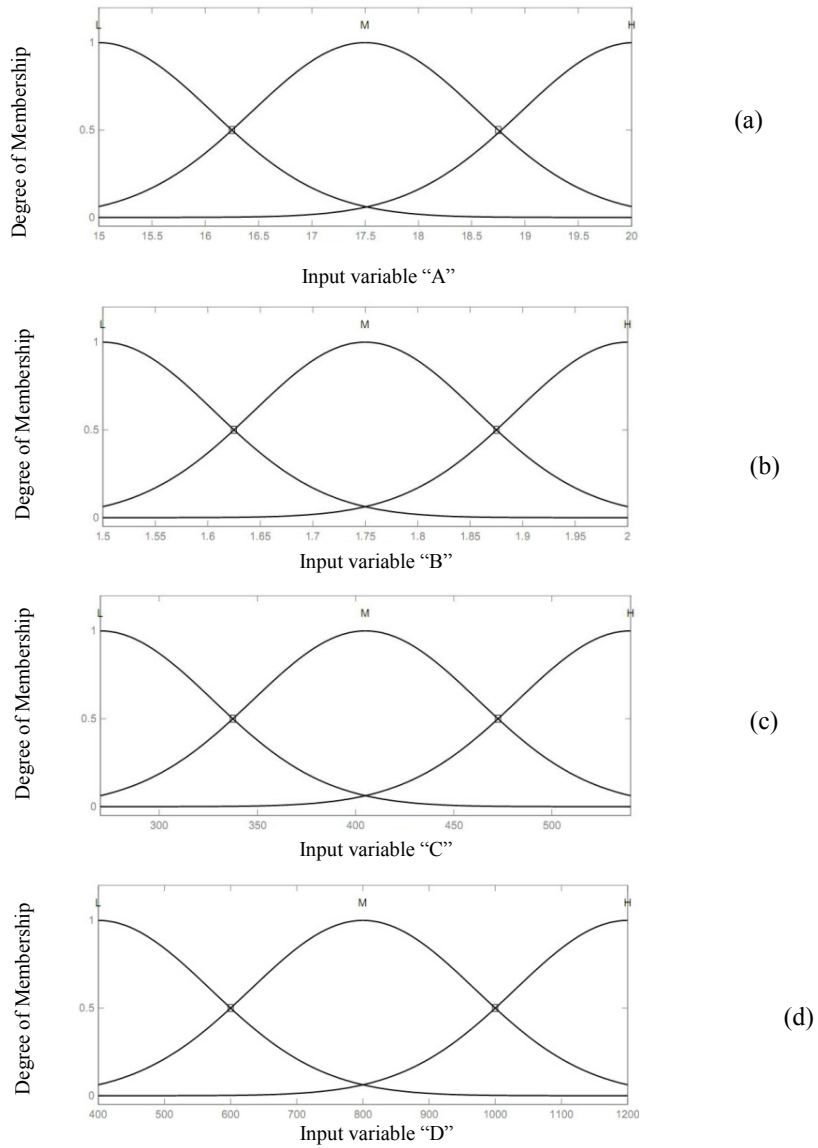

Fig. 5 Membership functions plots of input process parameters

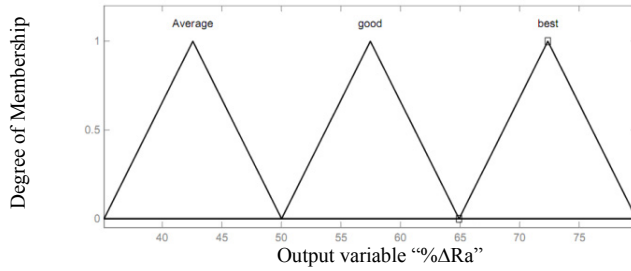

Fig. 6 Membership function for the output variable

4.2. Fuzzy Rules

Based on the knowledge extracted from experimental results, a set of 9 rules have been constructed. Experimental results were simulated in the MATLAB software based on mamdani fuzzy logic and they are as follows:

1. IF (A is L) and (B is L) and (C is L) and (D is L) then (%ΔRa is Average)
2. IF (A is L) and (B is M) and (C is M) and (D is M) then (%ΔRa is Average)
3. IF (A is L) and (B is H) and (C is H) and (D is H) then (%ΔRa is Average)
4. IF (A is M) and (B is L) and (C is M) and (D is H) then (%ΔRa is Best)
5. IF (A is M) and (B is M) and (C is H) and (D is L) then (%ΔRa is Average)
6. IF (A is M) and (B is H) and (C is L) and (D is M) then (%ΔRa is Average)
7. IF (A is H) and (B is L) and (C is H) and (D is M) then (%ΔRa is Best)
8. IF (A is H) and (B is M) and (C is L) and (D is H) then (%ΔRa is Good)
9. IF (A is H) and (B is H) and (C is M) and (D is L) then (%ΔRa is Good)

4.3. Defuzzification

Defuzzification is the conversion of a fuzzy quantity to a precise value. Even though many defuzzifying methods are available in this model, centroid of area (COA) defuzzification method is used due to its wide acceptance and capability in giving more accurate results compared to the other methods [20].

4.4. Validation of Fuzzy logic model

To validate the created Fuzzy logic model, three additional experiments were conducted to investigate the fuzzy model error. The chosen parameters for validation experiments and the obtained experimental %ΔRa and fuzzy logic predicted %ΔRa are tabulated in Table 6.

Table 6 Validation experimental results

Expt No.	A (V)	B (mm)	C (rpm)	D (Mesh)	%ΔRa		% Error
					From Expt.	From Fuzzy model	
1	16	1.6	300	600	39.94	42.8	7.160
2	18	1.8	450	800	49.53	52.9	6.803
3	19	1.9	500	1000	52.76	54.0	2.350

The individual error percentage is obtained by dividing the absolute difference between the predicted and measured by the measured value. Fig. 7 shows the fuzzy logic model prediction for the confirmation experiment no. 2.

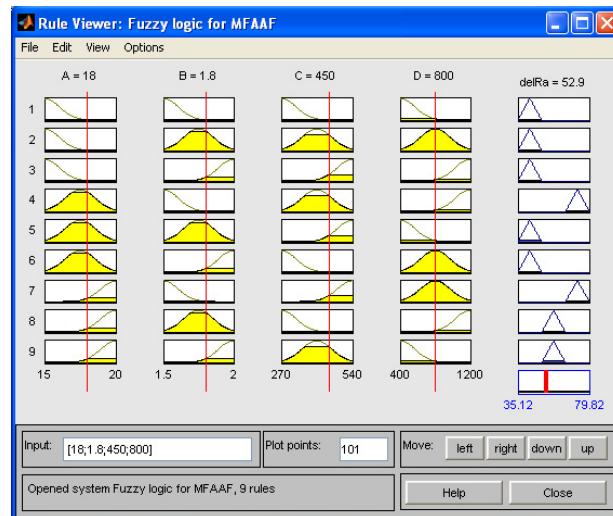

Fig 7. Screen shot of rule viewer

From the validation experiments, it is found that the obtained fuzzy logic model has a close relationship with the experimental values. The maximum % Error between the experimental and fuzzy logic model predicted values is 7.16%.

5. Conclusions

Based on the investigations from the present work the following conclusions are drawn:

- i) From the main effects of the process parameters, it is concluded that within the range of parameters evaluated, high level of voltage = 20 V (A3), a low level of working gap = 1.5 mm (B1), a high level of rotational speed = 540 rpm (C3), and a high level of abrasive size = 1200 (D3) are desirable for improving the surface finish of the SS316L material.
- ii) From the S/N ratio analysis, it is found that the percentage improvement of surface roughness is significantly influenced by the voltage(A) applied to the electromagnet, machining gap(B), rotational speed of the electro magnet(C) followed by abrasive size(D).
- iii) The obtained ANOVA result confirms with the result obtained by S/N ratio analysis.
- iv) Using the experimental data, a fuzzy model has been developed to predict the percentage improvement in surface finish. It is found that the maximum percentage deviations obtained between the fuzzy model values to the experimental values is 7.16%.
- v) The fuzzy model is tested using different set of process parameters values (3 additional test data) that are not used in already existing experimental data set. It is found that the Fuzzy model has a close relationship with the experimental values (7.16%).

References

- [1] Jayswal S.C, Jain V.K, Dixit P.M. Modeling and simulation of magnetic abrasive finishing process. *International Journal of Advanced Manufacturing Technology*, 2005, 26, pp. 477–490.
- [2] Sunil Jha, Jain V.K. Design and development of the magnetorheological abrasive flow finishing (MRAFF) process. *International Journal of Machine Tools and Manufacture*, 2004, Vol. 44, Issue 10, pp. 1019–1029.

- [3] Jain V.K. Magnetic field assisted abrasive based micro-/nano-finishing. *Journal of Materials Processing Technology*, 2009, 209, pp. 6022–6038.
- [4] Jain, V.K. Advanced Machining processes. 2002, Allied Publishers, Delhi.
- [5] Shinmura T, Takazawa K, Hatano E. Study on magnetic abrasive process-application to plane finishing. *Bulletin of the Japan Society of Precision Engineering*, 1985, 19(4), pp. 289–291.
- [6] Shinmura T, Takazawa K, Hatano E, Matsunaga M. Study on Magnetic Abrasive Finishing. *Annals of the CIRP*, 1990, 39, pp. 325–328.
- [7] Hitomi Yamaguchi, Takeo Shinmura, Study of an internal magnetic abrasive finishing using a pole rotation system discussion of the characteristic abrasive behavior, *Journal of international societies for precision engineering and nanotechnology*, 2000, 24, pp. 237-244.
- [8] Dhirendra K Singh, Jain V.K. Experimental investigations into forces acting during a magnetic abrasive finishing process. *International Journal of Advanced Manufacturing Technology*, 2006, 30, pp. 652-662.
- [9] Dhirendra K Singh, Jain V.K, Raghuram V, Komanduri R. Analysis of surface texture generated by a flexible magnetic abrasive brush, *Wear*, 2005, 259, pp. 1254-1261.
- [10] Jain V.K, Prashant Kumar, Behera P.K, Jayswal S.C. Effect of working gap and circumferential speed on the performance of magnetic abrasive finishing process, *Wear*, 2001, 250, pp. 384-390.
- [11] Dhirendra K Singh, Jain V.K, Raghuram V. Parametric study of Magnetic Abrasive finishing process, *Journal of materials processing technology*, 2004, 149, pp. 22-29.
- [12] Mori T, Hirota K, Kawashima Y. Clarification of magnetic abrasive finishing mechanism, *Journal of Materials Processing Technology*, 2003, 143-144, pp. 682-686.
- [13] Kremen G.Z, Elsayed E.A, Rafalovich V.I. Mechanism of material removal in the magnetic abrasive process and the accuracy of machining, *International Journal of Production Research*, 1996, 34, Issue 9, pp. 2629-2638.
- [14] Lih Dai Yang, Ching Tien, Han Ming Chow. Optimization in MAF operations using Taguchi parameter design for AISI304 stainless steel, *International Journal of Advanced Manufacturing Technology*, 2009, 42, pp. 595-605.
- [15] Jeong-Du Kim, Min-Seog Choi. Simulation for the prediction of surface accuracy in Magnetic abrasive machining, *Journal of Material Processing technology*, 1995, 53, pp. 630-642.
- [16] Mulik R, and Pandey P. Magnetic abrasive finishing of hardened AISI 52100 steel, *Int J. Adv Manuf Technology*, 2011, 55 (5-8), pp. 501-15.
- [17] JH Oh, SH Lee, Prediction of surface roughness in magnetic abrasive finishing using acoustic emission and force sensor data fusion, *Proceedings of the Institution of Mechanical Engineers, Part B: Journal of Engineering Manufacture, Proc. IMechE*, 2010, 225, pp. 853-865.
- [18] Reza Teimouri and Hamid Baseri. Artificial evolutionary approaches to produce smoother surface in magnetic abrasive finishing of hardened AISI 52100 steel, *Journal of Mechanical Science and Technology*, 2013, 27 (2), pp. 533-539.
- [19] L.A. Zadeh, Fuzzy sets, *Information and control*, 1965, 8, pp. 338–353.
- [20] Leung, R.W.K, Lau H.C.W, and Kwong C.K. An expert system to support the optimization of ion plating process: an OLAP-based fuzzy cum-GA approach. *Expert Systems with Applications*, 2003, 25(3), pp. 313-330.