

Heritability of Cellular Radiosensitivity: A Marker of Low-Penetrance Predisposition Genes in Breast Cancer?

S. A. Roberts,¹ A. R. Spreadborough,² B. Bulman,² J. B. P. Barber,² D. G. R. Evans,² and D. Scott²

¹Cancer Research Campaign Biomathematics and Computing Unit and ²Section of Molecular Genetics, Paterson Institute for Cancer Research, Christie Hospital NHS Trust, Manchester, United Kingdom

Summary

Many inherited cancer-prone conditions show an elevated sensitivity to the induction of chromosome damage in cells exposed to ionizing radiation, indicative of defects in the processing of DNA damage. We earlier found that 40% of patients with breast cancer and 5%–10% of controls showed evidence of enhanced chromosomal radiosensitivity and that this sensitivity was not age related. We suggested that this could be a marker of cancer-predisposing genes of low penetrance. To further test this hypothesis, we have studied the heritability of radiosensitivity in families of patients with breast cancer. Of 37 first-degree relatives of 16 sensitive patients, 23 (62%) were themselves sensitive, compared with 1 (7%) of 15 first-degree relatives of four patients with normal responses. The distribution of radiosensitivities among the family members showed a trimodal distribution, suggesting the presence of a limited number of major genes determining radiosensitivity. Segregation analysis of 95 family members showed clear evidence of heritability of radiosensitivity, with a single major gene accounting for 82% of the variance between family members. The two alleles combine in an additive (co-dominant) manner, giving complete heterozygote expression. A better fit was obtained to a model that includes a second, rarer gene with a similar, additive effect on radiosensitivity, but the data are clearly consistent with a range of models. Novel genes involved in predisposition to breast cancer can now be sought through linkage studies using this quantitative trait.

Received March 15, 1999; accepted for publication June 30, 1999; electronically published July 28, 1999.

Address for correspondence and reprints: Dr. Stephen A. Roberts, Cancer Research Campaign Biomathematics and Computing Unit, Paterson Institute for Cancer Research, Christie Hospital NHS Trust, Manchester M20 4BX, United Kingdom. E-mail: sroberts@picr.man.ac.uk

© 1999 by The American Society of Human Genetics. All rights reserved. 0002-9297/1999/6503-0026\$02.00

Introduction

A clear association between cancer predisposition and the hypersensitivity of cells to ionizing radiation (Taylor et al. 1975) was first demonstrated for patients with the recessively inherited multisystem disorder ataxia-telangiectasia (A-T [MIM 208900]). Assays of radiation-induced chromosome damage showed the greatest discrimination between A-T patients and normal controls (Taylor 1983). In such assays, 20 other inherited cancer-prone conditions have been shown to exhibit some degree of elevated chromosomal radiosensitivity (Scott et al. 1999). This suggests that defects in the processing of DNA damage of the type induced by ionizing radiation could contribute to cancer predisposition in these rare conditions. Among these in which the underlying gene has been identified, the most prevalent are A-T heterozygotes, estimated to constitute ~0.5% of the population and to have a fourfold-increased relative risk of breast cancer (Easton 1994). It has been estimated that ~4% (Easton 1994), but up to 18% (Swift et al. 1987), of all cases of breast cancer could be A-T–gene carriers. In an attempt to identify these on the basis of their enhanced chromosomal radiosensitivity, we tested an unselected series of patients with breast cancer, by irradiating lymphocytes in the G₂ phase of the cell cycle (Scott et al. 1994, 1999). We found that 42% (57/135) were sensitive, compared with 6% (6/105) of healthy controls (fig. 1). Clearly, there must be factors other than A-T heterozygosity that contribute to chromosomal radiosensitivity among cases of breast cancer and among controls. We postulated that other low-penetrance predisposing genes could be responsible. We found that age at diagnosis had no influence on radiosensitivity, suggesting that the putative genes result in a normal age at onset of breast cancer, as has been reported for A-T heterozygotes (Athma et al. 1996). Increased G₂ chromosomal radiosensitivity of cases of breast cancer, compared with controls, has now been confirmed in two independent studies (Parshad et al. 1996; Patel et al. 1997).

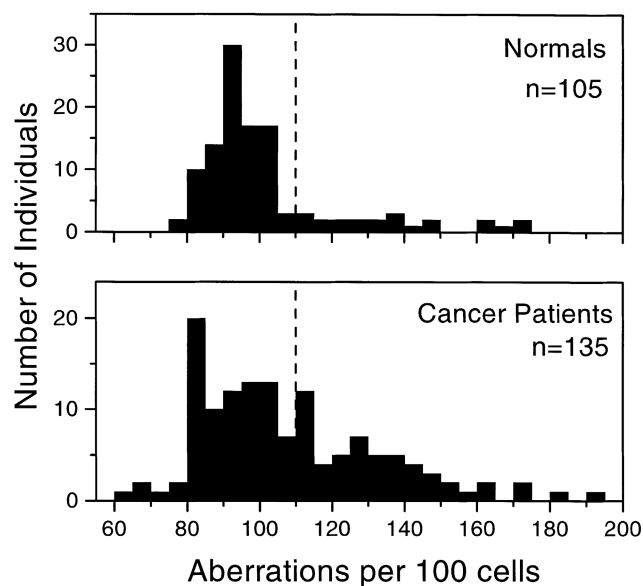

Figure 1 Yields of radiation-induced chromosomal aberrations in lymphocytes exposed to 0.5-Gy x-rays in the G₂ phase of the cell cycle. *Top*, Normal healthy donors. *Bottom*, Patients with breast cancer. The vertical dashed line indicates the cutoff point between a normal and a sensitive response. Data are from Scott et al. (1999).

The major highly penetrant genes that predispose to breast cancer—and that typically lead to a strong family history of the disease—are *BRCA1* and *BRCA2* (Ford et al. 1998). These genes have a role in DNA repair after exposure of cells to ionizing radiation (Kinzler and Vogelstein 1997). Another high-penetrance predisposing gene is *TP53*, associated with the cancer-prone Li-Fraumeni syndrome (Varley et al. 1997). However, <5% of cases of breast cancer will be associated with mutations in any of these three genes (Goldgar et al. 1996). The concept that, in addition to these highly expressed genes, there are other, low-penetrance genes predisposing to breast cancer in a substantial proportion of cases is supported by epidemiological investigations (Teare et al. 1994; Ford et al. 1998). Our results suggest that among these low-penetrance genes are those involved in the processing of DNA damage (International Commission on Radiation Protection 1999) and that these, when defective, lead to enhanced chromosomal radiosensitivity. A small proportion of these may be mutant *ATM* genes in heterozygotes, although recent findings suggest that the frequency of *ATM* mutations among patients with breast cancer may be considerably lower than early estimates (Swift et al. 1987; Bishop and Hopper 1997).

Our hypothesis would be considerably strengthened if it could be shown that chromosomal radiosensitivity is an inherited characteristic in families of patients with

breast cancer. Here we report the results of such an investigation.

Subjects and Methods

Patients and Families

Families were selected on the basis of the following criteria: (1) the level of chromosomal radiosensitivity of the patient with cancer (the index case) within the family, established on the basis of our previous study (Scott et al. 1999), was used to select the 16 most sensitive index cases who met the remaining criteria, as well as an additional 4 index cases with aberration yields close to the modal value of the historic controls; (2) the residence of family members was within a reasonable distance of our institute, so that blood samples could be taken in their homes and transported to our institute by our phlebotomist (this was to avoid transportation of samples from distant sources by courier, because poor reproducibility of results has occasionally been obtained from such samples) (Scott et al. 1999); (3) the patients were willing to participate in the study; and (4) the patients were alive and well and had at least one first-degree relative willing and able to participate. All these studies were performed with the approval of the South Manchester Health Authority Ethical Committee.

Tests were done on 60 blood relatives of 20 index cases during a period of 2 years, on 51 different occasions, with two to eight blood samples being tested on each occasion. Index cases were questioned about occurrences of breast and other cancers within their families, but no attempt was made to confirm this information, since it was not our intention within this study to obtain detailed estimates of familial cancer risk (see the Discussion section, below). Much larger population- or family-based case/control studies would be required for this purpose. Expected numbers of breast cancer cases were derived from regional cancer statistics.

In total, 43 healthy controls were also tested. These comprised 25 “traveling” controls, whose blood samples accompanied the samples from family members, and 18 “local” controls, from donors in our institute. The traveling samples were included to control for the possibility that transportation of samples over relatively short distances in this study might introduce the problems of reproducibility that have been noted above. Fifteen of the traveling controls were spouses of family members and thus contribute to the study both as nonblood-relative controls and as members of the pedigrees for genetic analysis. Some of the local controls donated blood samples on several (up to nine) occasions. All index cases had previously been tested before radiotherapy was administered. The majority (18/20) were retested 5–39 mo

after therapy; 2 patients were retested twice. Six blood relatives were tested on more than one occasion. A total of 164 samples were tested in this study.

Methods

The assay.—Full details of the methods used in this study are given in the work of Scott et al. (1999). In brief, cultures of whole blood were established <24 h after blood was drawn, and lymphocytes were stimulated to proliferate with the mitogen, phytohemagglutinin. At 72 h poststimulation, cells were exposed to 0.5-Gy x-rays or were sham irradiated. At 30 min after irradiation, colcemid was added for 60 min, to arrest cells at metaphase that were in the G₂ phase at the time of irradiation. Harvesting procedures, including hypotonic treatment, were all performed at 4°C. For analysis, slides were coded and randomized; 50 metaphases from each sample were analyzed for chromosomal damage (mainly chromatid gaps and breaks). The low yields of aberrations seen in unirradiated cells (0–14/100 cells, the highest values being found in postradiotherapy patients) were subtracted from those in irradiated cells of each sample, to give the radiation-induced yields.

Statistical analysis.—The distribution of aberration yields among the family members was fitted to a mixture model based on lognormal distributions, by direct maximization of the log likelihood (commingling analysis). The index cases and controls were excluded, since they potentially form diverse populations that may bias the analysis. In total, 78 family members were used in this analysis, comprising the 60 blood relatives and 18 non-blood relatives ascertained through the index cases. Models consisting of one to four lognormal distributions were considered, fitting a common variance parameter, and the significance of extra components was assessed by standard likelihood-ratio tests. Adding the index cases and control individuals and/or allowing different variances for the distributions gave essentially identical results.

To investigate possible genetic mechanisms that might be compatible with the data, we performed a segregation analysis (Morton and McLean 1974). A log transformation was applied to the data, on the basis of the observed distribution of values. The pretherapy aberration yields were used for the index cases, along with the mean values when there were repeat samples from the remaining individuals. A nested series of mixed (major gene plus polygenic background) models was considered, the full mixed model containing a single locus with two alleles and a residual Gaussian variance. This residual variance was partitioned into heritable and non-heritable components, with the heritability parameter (H), the ratio of the two variance components, having values between 0 (no polygenic heritability) and 1. The

nonheritable (random) component is usually attributed to environmental effects; however, in the present study, with its inherent assay error, we might expect the random component to be dominated by the assay error.

Simpler Mendelian models with either the major gene alone or solely polygenic effects were compared with the full mixed model. Two nonhereditary models were also considered, a polygene-only model with no heritability ($H = 0$; i.e., a simple Gaussian model) and a general transmission (major environmental) model, with gene transmission probabilities equal to the gene frequencies (essentially the model used in the commingling analysis discussed above). Finally, models with non-Mendelian transmission were considered, in which the allele-transmission probabilities for the major locus (τ_1 , τ_2 , and τ_3) were allowed to vary from their Mendelian values of $\tau_1 = 1$, $\tau_2 = .5$, and $\tau_3 = 0$ (Elston and Stewart 1971). First, we considered relaxing the constraint that $\tau_2 = .5$ and then considered a model in which all three transmission parameters were fitted to the data. These models provide a test for Mendelian segregation, and their use provides a safeguard against falsely imputing a genetic mechanism in situations in which the assumptions of the model (particularly normality) are violated (Demenais et al. 1986). Rejection of the Mendelian-transmission parameters indicates either that there is a more complex genetic mechanism, that the assumptions of the model are violated, or that the apparent major-locus effect is in fact a consequence of non-Mendelian commingling.

Harvey-Weinberg equilibrium was assumed, and equal variances were fitted for each genotype. Likelihoods were conditioned on the probands, to allow for ascertainment bias, under the assumption of an approximation to single selection (Thompson and Cannings 1979).

Models were compared with the full mixed model by standard likelihood-ratio tests, and models that proved to be a significantly worse fit to the data than was the full model were rejected. The model with the fewest parameters not rejected by this comparison was then accepted as the most parsimonious model consistent with the data. Analyses were performed by means of the PAP package, version 4.0 (Hasstedt and Cartwright 1981), subroutines papfqhw, paptctp or paptcms, papprmv, papwgc (Hasstedt 1993), papenqa, and papcrqa.

Since all the single-gene models showed an excess of individuals with large residual deviations from the observed phenotypic values, an additional model with two major biallelic genes and no polygenic background was considered as the simplest Mendelian model representing a more complex genetic basis. This was compared with both the full model and the accepted, most parsimonious model, by likelihood-ratio tests. In view of the complexity of two-locus models (with nine genotypes, only six of which are likely to be represented in the data set),

it is not practicable (nor would it be very informative) to consider the equivalent mixed and non-Mendelian models in a two-gene framework.

Results

Our earlier study of 135 patients and 105 controls showed evidence of an overlapping bimodal distribution of radiosensitivity values, with a value of 110 chromosome aberrations/100 cells at the point of overlap (Scott et al. 1999). This was used as the cutoff point between a normal and a sensitive response (fig. 1). Of the 20 index cases selected, 16 were shown to be sensitive in the test; 45 of their blood relatives were studied. Four patients with a normal response were also selected, and 15 of their blood relatives were tested.

Assay Reproducibility

As a measure of assay reproducibility in our earlier studies, we performed repeat tests on 28 local controls (99 samples) and obtained a coefficient of variation (CV) of 7% for intraindividual variability (Scott et al. 1999). To test for any possible influence of transportation on assay reproducibility in the present study, we compared the intraindividual CV of eight local controls (25 samples) with that of transported samples from 10 family members (20 samples). The CVs were computed on the basis of a one-way analysis of variance. Both groups had CVs of ~7% (table 1), with no significant difference between them ($P = .36$; variance-ratio *F*-test on log-transformed data).

To test for any effect of radiotherapy on radiosensitivity, we compared pre- and posttherapy values in 18 index cases (table 2). There was no significant difference ($P = .81$; Wilcoxon signed-rank test).

Sensitivity of Family Members

Results of tests for radiosensitivity are summarized in table 2. The mean sensitivity of the 45 blood relatives of the 16 sensitive index cases was intermediate between that of the controls and that of the patients and was significantly different from both ($P < .001$ for both com-

parisons, by Mann-Whitney U-tests). On the other hand, the 15 first-degree relatives of the four patients with a normal response had an average sensitivity similar to that of the patients and controls. When the sensitivity cutoff value of 110 was used, 62% (23/37) of the first-degree relatives of sensitive patients were also sensitive (fig. 2), compared with only 7% (1/15) of first-degree relatives of normal patients ($P < .001$, by Fisher's exact test). One (2%) of the 43 controls was reproducibly sensitive (fig. 2). Four of eight second-degree relatives of sensitive patients were also sensitive.

The distribution of radiosensitivities among the 78 family members (excluding index cases) is shown in figure 3. Using maximum-likelihood methodology, we have fitted this distribution to a sum of lognormal distributions (a mixture model or commingling analysis), using a common variance for each peak. We can discern three statistically significant populations within the data, with means of 88.2, 122.7, and 175.9 and with a common CV of 7.8% (fig. 3). The width of the peaks was only marginally greater than the estimated 6%–7% variability of the assay. The addition of a fourth peak was not statistically significant ($P = .18$); neither was there any significant improvement in the fit when the distributions were allowed to have different widths ($P = .26$). The proportion of the family members in each of the three populations was 61%, 32%, and 7%, respectively.

Segregation of Sensitivity in Families

The increased radiosensitivity (i.e., above that in controls) of healthy blood relatives supports the hypothesis that the sensitivity has a genetic basis, and the trimodal distribution of radiosensitivities within the families is strongly suggestive of a major gene segregating within the families. We have therefore performed a segregation analysis on the pedigree data (95 individuals in 20 families; see pedigrees shown in fig. 4), to further investigate the heritability of radiosensitivity and to elucidate potential genetic mechanisms.

We consider a series of mixed genetic models containing a major gene with two alleles (*n* and *s*) and an additive polygenic background. Eight of the models

Table 1

Assay Reproducibility of Local and Transported Samples, Assessed on the Basis of the Intraindividual Variability in Aberration Yields of Repeated Samples

	No. of Individuals (Samples)	Mean ± SD (CV) of Raw Aberration Yield	Log-Transformed SD
Traveling samples ^a	10 (20)	129.7 ± 8.5 (6.5%)	.076
Local controls	8 (25)	90.2 ± 6.3 (7.0%)	.070
All samples	18 (45)	107.7 ± 7.2 (6.6%)	.072

^a Repeat samples from six blood relatives of index cases, one spouse, and two index cases tested twice posttherapy; pretherapy samples were not included.

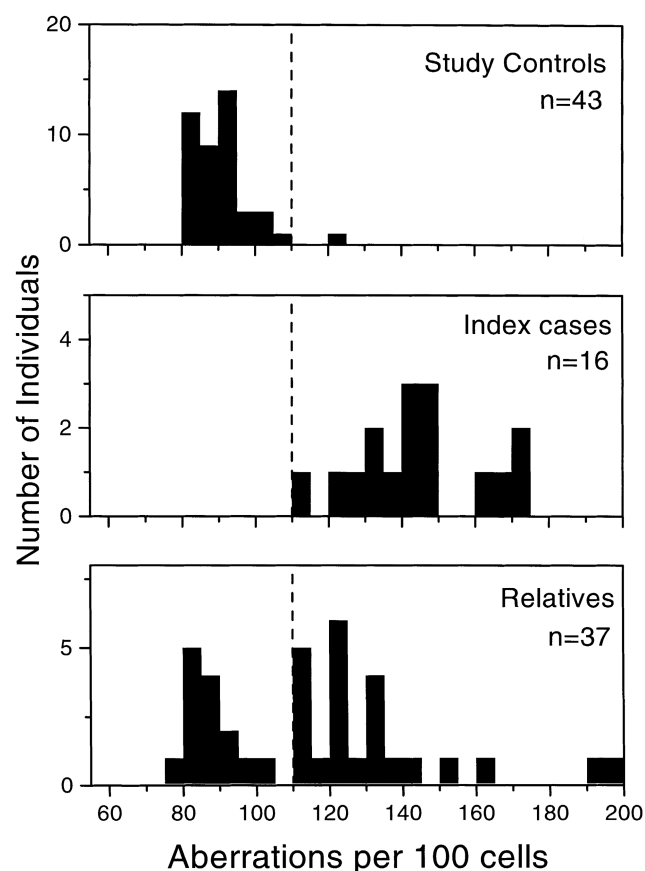

Figure 2 Yields of radiation-induced chromosomal aberrations in lymphocytes exposed to 0.5-Gy x-rays in the G_2 phase of the cell cycle. *Top*, Healthy controls tested in parallel with samples from the families. The sensitive individual (to the right of the vertical dashed line) was tested twice and gave values of 120 aberrations/cells and 126 aberrations/100 cells, respectively. *Middle*, Patients with breast cancer, selected as being sensitive in the assay when tested before radiotherapy. *Bottom*, First-degree relatives of the patients with breast cancer who are shown in the middle panel.

considered are shown in table 3. The model fits are compared with that of the most general model of non-Mendelian transmission of the three major phenotypes and a polygenic component (model 1). The three models that do not include a major-gene effect (models 3–5) are clearly rejected. The two models that include a major gene (models 2 and 6) cannot be rejected. The most parsimonious of these two models is that with a single gene only and no polygenes (model 2), and thus we accept this as the simplest genetic model consistent with the data. The addition of a polygenic component to this model does not significantly improve the fit ($P = .11$).

Thus, the segregation analysis suggests that the data can be reasonably well fitted by a single gene segregating within these families and that this single gene is sufficient to account for 82% of the variability in sensitivity be-

tween family members. The genotype means indicate that the heterozygote, *ns*, has a phenotypic value very close to half the difference between those of the two homozygotes, *nn* and *ss* (albeit on a logarithmic scale)—that is, there is no dominance, and the two alleles combine additively. The two alleles act in a codominant fashion with heterozygote expression (e.g., see family 1 in fig. 5). The difference between the *nn* and *ss* genotypes, in units of the SD (often called the “displacement”) is 7.8. This large displacement enables reasonably accurate genotype estimation and facilitates the detection of major-gene effects in such a relatively small sample. The residual SD of 0.10 is just a little larger than the value of 0.072, which would be expected from assay repeatability alone, although it does suggest an additional environmental contribution to the variance, of almost the same magnitude as the assay variability.

However, there were indications that the single-gene genetic model was not adequate to explain the data fully and that a more complex model was required. For readers familiar with segregation analyses, the details of the inadequacies are given in the next two paragraphs; the general reader may safely ignore these details.

First, we tested whether the putative genes segregate with frequencies consistent with Mendelian transmission; the single-gene model was compared with models in which we relax the constraint that the transmission probabilities τ_1 , τ_2 , and τ_3 , for the three genotypes *nn*, *ns*, and *ss*, respectively, take the values $\tau_1 = 1$, $\tau_2 = .5$, and $\tau_3 = 0$. The first test, often considered to be the most appropriate test for Mendelian inheritance (Lalouel et al. 1983; Demenais et al. 1986), relaxes the constraint that $\tau_2 = .5$, and the fitted value obtained is $\tau_2 = .35$,

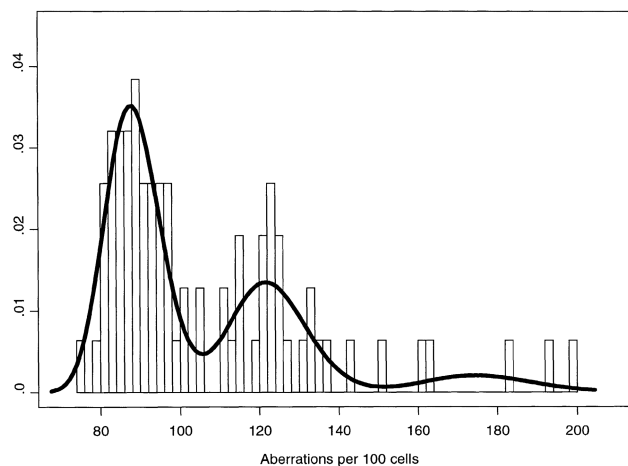

Figure 3 Relative-density histogram of the distribution of the mean G_2 values of the 78 family members in the study (excluding index cases). The line indicates the fitted density functions with three log-normal peaks of equal width.

Table 2
Yields of Radiation-Induced Aberrations in the Various Groups, Proportions of Sensitive Cases, and Significance Levels

Family Type and Category (No.)	Mean ± SD Radiation-Induced Aberration Yield	No. (%) Sensitive ^a	Significance ^b
Sensitive proband:			
Index cases:			
Pretherapy (16)	142.8 ± 19.5	16 (100)	
Posttherapy (14)	144.9 ± 20.2	13 (93)	
Relatives:			
All first degree (37)	115.4 ± 29.2	23 (62)	<.001
Parents (3)	114.7 ± 25.3	2 (67)	.11
Sibs (12)	129.6 ± 27.2	11 (92)	<.001
Children (22)	107.7 ± 28.8	10 (45)	.048
All second degree (8)	120.5 ± 34.4	4 (50)	.001
Normal proband:			
Index cases:			
Pretherapy (4)	91.5 ± 5.0	0 (0)	
Posttherapy (4)	91.5 ± 5.3	0 (0)	
Relatives:			
All first degree (15)	88.3 ± 9.6	1 (7)	.20
Sibs (9)	90.7 ± 11.0	1 (11)	.60
Children (6)	84.7 ± 6.4	0 (0)	.13
Controls:			
All (43)	90.3 ± 8.0	1 (2)	
Traveling (25)	89.5 ± 9.1	1 (4)	
Local (18)	91.5 ± 6.5	0 (0)	

^a For a cutoff of 110 aberrations/100 cells.

^b Comparison of aberration yields versus those in controls, by Mann-Whitney U-test.

which is not significantly different from the Mendelian value ($P = .087$). However, a more stringent test, in which all three transmission probabilities are unrestricted, yields an improvement to the fit, which just achieves statistical significance ($P = .045$). This borderline significance could indicate a true failure of Mendelian inheritance, with a major environmental effect leading to three phenotypes that segregate with non-Mendelian probabilities. Given the significant trimodal distribution of sensitivities, the wide separation of the putative genotypes, and the underlying biology, this is highly unlikely. Alternatively, the failure of the model to pass the most stringent test of Mendelian inheritance could be due to some residual skewness in the sensitivity distributions following the logarithmic transformation (Deménais et al. 1986) is calculated, but there is little evidence of this (fig. 3). A more likely possibility is that the inheritance is Mendelian, but with a more complex genetic mechanism.

Second, examination of the residuals indicates a generally good fit to the single-gene model, in that most of the predicted phenotypes are close to the values observed; however, there were exceptions to this, most notably in one family (family 8) in which a very sensitive individual (who had repeated scores of 162 and 160) with a normal spouse (who had a score of 88) has children with scores of 162 and 182 (fig. 5). Since the spouse

is normal, on the basis of a single-gene model these children must be heterozygous (mean score 128), 2.4 and 3.5 SDs, respectively, from the observed values. Similar but less extreme examples are also found in three other families (families 4, 6, and 15).

Thus, since there was some evidence of a lack of fit to the single-gene model, and since there was already one gene, *ATM*, known to convey a radiosensitive phenotype in a proportion of cases of breast cancer, we were led to consider more-complex genetic models. Specifically, we considered a model with two major genes, Mendelian inheritance, and no polygenes. Surprisingly, this model with seven extra parameters proved to be a significantly better fit ($2 \times \log \text{likelihood} = 88.1$) than both our most-parsimonious single-gene model (table 3, model 2; $P = .007$) and the full general-transmission model (table 3, model 1; $P = .009$). Thus, this model provides a significantly better explanation of the data than does the single-gene model with non-Mendelian transmission. The genotype means for this model are given in table 4. With this model, the within-genotype SD is 0.077, which is very close to the estimated assay error; the residual error is thus entirely accounted for by the assay error. Putative genotypes for family 8, for the two-gene model, are given in figure 5.

The genotype means (table 4) indicate two genes with similar phenotypic effects, with these effects being ad-

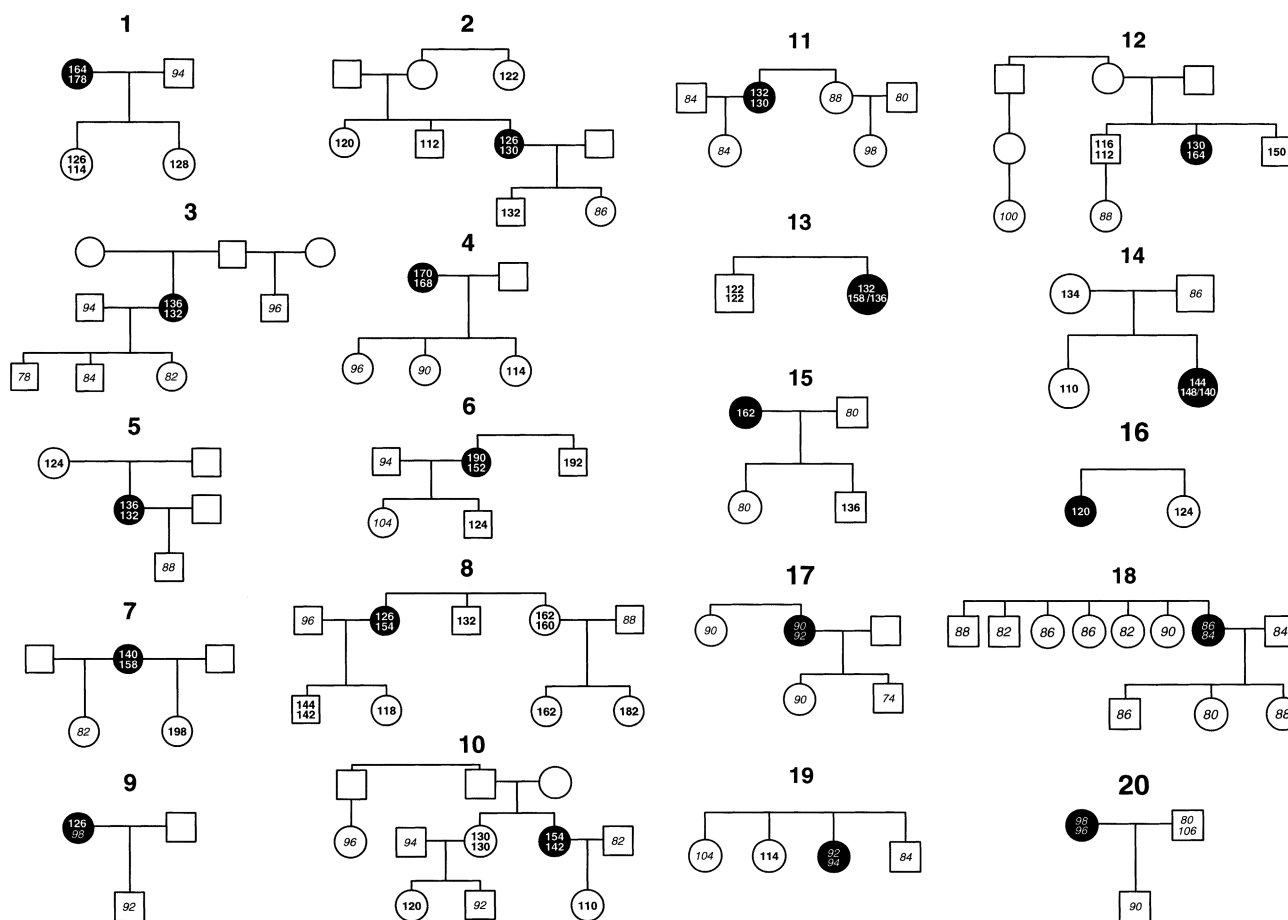

Figure 4 Pedigrees of the 20 participating families. Index patients with breast cancer are represented by blackened circles. Numbers within the symbols are scores in the assay; results of repeat tests are given as two or three numbers within a symbol. For index cases for which there are two or three numbers, the upper value is for preradiotherapy testing, and the lower value(s) is/are posttherapy. Sensitive responses are in boldface; normal responses in italics. In order to anonymize the pedigrees, we have not included ages of family members, regardless of whether they are alive or whether the family has cancers other than that in the index case.

ditive. Thus, again, the alleles act in a codominant manner, with heterozygote expression. However, only the double heterozygote is well estimated by the data set, so the nature of the interaction between the two putative genes is not well determined. The two-gene model accounts for some 91% of the variance in radiosensitivities between family members.

The analysis using the various single-gene models was repeated, excluding the four families in which both putative genes were segregating (the four outliers above). Very similar results were obtained, with no evidence for non-Mendelian transmission once these families had been excluded, again indicating that the mode of inheritance is Mendelian once the effects of the second gene have been accounted for.

Cancer Risk

Cancer frequencies in the 16 families with elevated radiosensitivity did not suggest a high-penetrance sus-

ceptibility to breast cancer or other cancers in any family. Three cases of breast cancer were observed in 18 first- and second-degree female relatives, the expected number being 1.35.

Discussion

Our results provide clear evidence of heritability of chromosomal radiosensitivity of G₂ lymphocytes in families in which there is a case of breast cancer. Earlier studies of small numbers of female-only blood relatives of patients with breast cancer showed that, on average, they were more chromosomally radiosensitive than were normal controls without a family history of breast cancer. However, these studies did not address the question of heritability by examining the segregation of sensitivity within families (Parshad et al. 1996; Patel et al. 1997; Helzlouer et al. 1996). Helzlouer et al. (1995) investigated heritability in just one family, in which four of six

Table 3**Model Parameters from Segregation Analysis of G₂ Radiosensitivity in 20 Families**

	Model 1: General Transmission and Polygenes	Model 2: Major-Gene Only	Model 3: Sporadic	Model 4: Polygene Only	Model 5: Major- Environmental Only	Model 6: Major Gene + Polygene	Model 7: Major-Gene-Only, Non-Mendelian	Model 8: General- Transmission Only
Allele frequency, <i>p</i>	.96	.96	NA	NA	.77	.96	.98	.94
Means:								
nn	4.48	4.48	4.63	4.67	4.48	4.48	4.48	4.47
ns	4.85	4.85	NA	NA	4.81	4.84	4.85	4.81
ss	5.27	5.27	NA	NA	5.17	5.30	5.28	5.18
Residual SD	.101	.101	.23	.21	.077	.10	.10	.077
Polygene heritability, <i>H</i>	0 ^a	[0]	NA	.79	[0]	.30	[0]	[0]
Genotype-transmission probabilities: ^b								
τ_1	.96	[1]	NA	NA	[<i>p</i>]	[1]	[1]	.96
τ_2	.37	[.5]	NA	NA	[<i>p</i>]	[.5]	.35	.37
τ_3	.29	[0]	NA	NA	[<i>p</i>]	[0]	[0]	.29
2 × Log likelihood	76.6	68.5	9.8	18.1	50.8	71.2	71.4	76.6
No. of fitted parameters	9	5	2	3	5	6	6	8
Likelihood-ratio χ^2 -test <i>P</i> values:								
Compared with model 1	NA	.090	<.001	<.001	<.001	.15	.16	1.0
Compared with model 2	.090	NA	<.001	NA	NA	.11	.087	.045

NOTE.—NA = not applicable. Parameters in square brackets were held fixed in the model.

^a Fitted parameter value at its lowest boundary.

^b τ_1 , τ_2 , and τ_3 take values of 1, .5, and 0, respectively, for Mendelian inheritance (see Subjects and Methods).

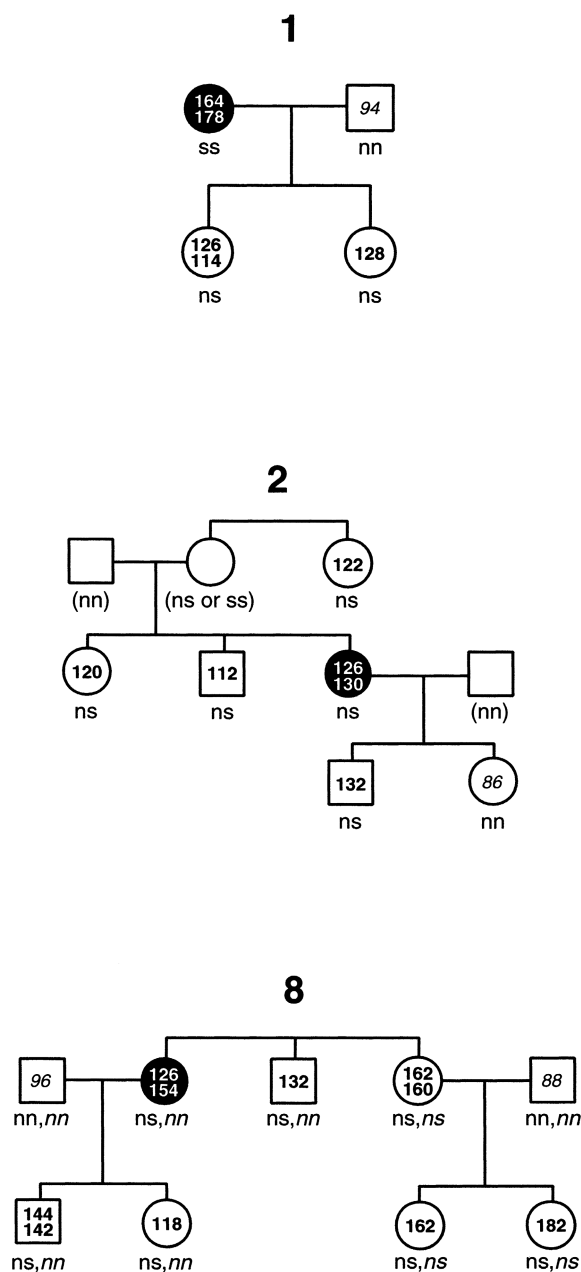

Figure 5 Pedigrees of families 1, 2, and 8, showing putative genotypes based on the single-gene (in the case of families 1 and 2) or two-gene (in the case of family 8) models. “n” and “s” denote alleles that confer a normal or a sensitive response in the assay, respectively; where two putative genes are segregating, the genotypes of the second gene are italicized; where the symbols are in parentheses, the genotypes have been inferred. Other symbols are as in figure 4.

sisters had breast cancer. Two of the three affected sisters who were tested were radiosensitive, and five of seven first-degree relatives tested also were sensitive. However, the segregation of sensitivity was non-Mendelian, in that the affected sister with a normal sensitivity score, who

had a husband who also had a normal score, had a son who was radiosensitive.

The segregation analysis presented here shows clear evidence of Mendelian heritability of chromosomal radiosensitivity, the inheritance being dominated by one or more major genes with large and additive effects. A single major gene can account for 82% of the radiosensitivity variance between the members of the 20 families; however, the data are better explained by the inclusion of a second, rarer gene, but this is largely because of the poor fit to the single-gene model of one or two individuals in each of three families. Other, more complex genetic mechanisms would probably fit the data as well, and the mechanisms and genes may differ between families.

It is rather surprising that a data set of the limited size presented here is sufficiently powerful to allow us to detect statistically significant major genes; however there are three factors that act in our favor: (1) the large phenotypic effect of the major genes (with a displacement value of nearly 8), (2) the lack of any confounding covariates, and (3) the lack of any detectable environmental influence. Against this we have to put the intrinsic assay variability, which will mask any polygenic factors up to a CV of ~10%. The large displacement, with good phenotypic separation between the normal and sensitive genotypes, ought to make gene mapping by linkage analysis relatively straightforward. However, the relative abundance of the putative gene in the population, along with the likely presence of multiple genes, will complicate any linkage study. The best approach may be a study based on a few large families, but other approaches are possible.

At present the identity of the putative genes is unknown. Their characteristics are that they appear to be involved in the processing of DNA damage of the type induced by ionizing radiation and that mutants (or variants) are relatively common within the normal population (Scott et al. 1994, 1999; Parshad et al. 1996) and present at high frequency among patients with breast cancer (Scott et al. 1994, 1999; Parshad et al. 1996; Patel et al. 1997). We predict that they lead to breast-cancer predisposition at a low level of penetrance. Possible candidates are rare microsatellite variants (polymorphisms) associated with XRCC DNA-repair genes. Mutations within the XRCC genes confer cellular radiosensitivity, and Price et al. (1997) have found that the frequency of rare microsatellite polymorphisms is very high (58% [11/19 cases]) among patients with cancer (including breast cancer) and absent from 34 healthy controls. Minisatellite variants associated with the *H-ras-1* proto-oncogene have been implicated as low-penetrance breast cancer-predisposing genes in ~10% of cases, and it has been suggested that these variants might disrupt the controlled expression of the *H-ras-1* gene

Table 4
Genotype Values for the Two-Gene Model

GENE 1 (FREQUENCY 6.5%)	GENE 2 (FREQUENCY 1.8%) ^a		
	Null	Heterozygote	Homozygote
Null	4.47 ± .01	4.82 ± .03	5.03 ± .28
Heterozygote	4.79 ± .03	5.11 ± .04	[5.05 ± .67]
Homozygote	5.27 ± .05	[4.54 ± .19]	[5.08 ± 2.45]

^a Data in square brackets are for genotypes predicted to occur with a frequency less than once in the data set and that therefore are poorly determined.

(Krontiris et al. 1993); however, known mutations in *H-ras-1* either have no influence on cellular radiosensitivity (Su and Little 1992) or confer *radioresistance* (Bernhard et al. 1998). It seems unlikely, therefore, that the radiosensitive individuals identified in our study will be carriers of these predisposing minisatellite variants. Only a small proportion of these radiosensitive individuals are likely to be A-T heterozygotes (see the Introduction section, above).

In this study we did not attempt to determine an accurate or complete family history of cancer. The limited information obtained from interviewing the probands did not indicate any dramatic history of cancer within the families. The relative risk of breast cancer was only two- to threefold greater than that in controls, with the numbers of cases being too small for statistical analysis. In our earlier work (Scott et al. 1999), a comparison of the numbers of patients and controls who were sensitive in the assay would suggest an increased (approximately fivefold) lifetime breast-cancer risk associated with the radiosensitive phenotype. However, in that study the populations of cases and controls were not sufficiently well matched, and the study size was not large enough to allow us to accurately determine the odds ratio. There is a clear need for much larger, carefully planned epidemiological studies to quantify the risk for "sensitive" individuals and their relatives. The current, crude, risk estimates suggest that the radiosensitive genotypes confer a cancer risk similar to that seen in the A-T heterozygotes (who have a similar sensitivity in the assay [Scott et al. 1994]), in whom there is reported to be a fourfold-increased cancer risk (Easton 1994) but no significant family history of cancer (Bishop and Hopper 1997).

Acknowledgments

We thank all the family members and controls for their invaluable contribution to this study. Funding was provided by the Cancer Research Campaign and the National Radiological Protection Board of the United Kingdom.

Electronic-Database Information

The accession number and URL for data in this article are as follows:

Online Mendelian Inheritance in Man (OMIM), <http://www.ncbi.nlm.nih.gov/Omim> (for A-T [MIM 208900])

References

- Athma P, Rappaport R, Swift M (1996) Molecular genotyping shows that ataxia-telangiectasia heterozygotes are predisposed to breast cancer. *Cancer Genet Cytogenet* 92:130–134
- Bernhard EJ, McKenna WG, Hamilton AD, Sebti SM, Qian Y, Wu JM, Muschel RJ (1998) Inhibiting *Ras* prenylation increases the radiosensitivity of human tumor cell lines with activating mutations of *ras* oncogenes. *Cancer Res* 58:1754–1761
- Bishop DT, Hopper J (1997) AT-ributable risks. *Nat Genet* 15:226
- Demerais F, Lathrop M, Lalouel JM (1986) Robustness and power of the unified model in the analysis of quantitative measurements. *Am J Hum Genet* 38:228–234
- Easton DF (1994) Cancer risks in A-T heterozygotes. *Int J Radiat Biol* 66 Suppl 6:S177–S182
- Elston RC, Stewart J (1971) A general model for the genetic analysis of pedigree data. *Hum Hered* 21:523–542
- Ford D, Easton DF, Stratton M, Narod S, Goldgar D, Devilee P, Bishop DT, et al (1998) Genetic heterogeneity and penetrance analysis of the BRCA1 and BRCA2 genes in breast cancer families. *Am J Hum Genet* 62:676–689
- Goldgar DE, Stratton MR, Eeles RA (1996) Familial breast cancer. In: Eeles RA, Ponder BAJ, Easton DF, Horwich A (eds) *Genetic predisposition to cancer*. Chapman & Hall, London
- Hasstedt SJ (1993) A variance components/major locus likelihood approximation for quantitative, polychotomous and multivariate data. *Genet Epidemiol* 10:145–158
- Hasstedt S, Cartwright P (1981) PAP: pedigree analysis package. Department of Medical Biophysics, University of Utah, Salt Lake City
- Helzlsouer KJ, Harris EL, Parshad R, Fogel S, Bigbee WL, Sanford KK (1995) Familial clustering of breast cancer: possible interaction between DNA repair proficiency and radiation exposure in the development of breast cancer. *Int J Cancer* 64:14–17
- Helzlsouer KJ, Harris EL, Parshad R, Perry HR, Price FM, Sanford KK (1996) DNA repair proficiency: potential susceptibility factor for breast cancer. *J Natl Cancer Inst* 88:754–755
- International Commission on Radiation Protection (1999) Genetic susceptibility to cancer. International Commission on Radiation Protection publ 79. *Ann ICRP* 28:1–157

- Kinzler KW, Vogelstein B (1997) Cancer susceptibility genes: gatekeepers and caretakers. *Nature* 386:761-763
- Krontiris TG, Devlin B, Karp DD, Robert NJ, Risch N (1993) An association between the risk of cancer and mutations in the HRAS1 minisatellite locus. *N Engl J Med* 329:517-523
- Lalouel JM, Rao DC, Morton NE, Elston RC (1983) A unified model for complex segregation analysis. *Am J Hum Genet* 35:816-826
- Morton NE, McLean CJ (1974) Analysis of family resemblance. III. Complex segregation of quantitative traits. *Am J Hum Genet* 26:318-330
- Parshad R, Price FM, Bohr VA, Cowans KH, Zujewski JA, Sanford KK (1996) Deficient DNA repair capacity, a predisposing factor in breast cancer. *Br J Cancer* 74:1-5
- Patel RK, Trivedi AH, Arora DC, Bhatavdekar JM, Patel DD (1997) DNA repair proficiency in breast cancer patients and their first-degree relatives. *Int J Cancer* 73:20-24
- Price EA, Bourne SL, Radbourne R, Lawton PA, Lamerdin J, Thompson LH, Arrand JE (1997) Rare microsatellite polymorphisms in the DNA repair genes XRCC1, XRCC3 and XRCC5 associated with cancer in patients of varying radiosensitivity. *Somat Cell Mol Genet* 23:237-247
- Scott D, Barber JBP, Spreadborough AR, Burrill W, Roberts SA (1999) Increased chromosomal radiosensitivity in breast cancer patients: a comparison of two assays. *Int J Radiat Biol* 75:1-10
- Scott D, Spreadborough A, Levine E, Roberts SA (1994) Genetic predisposition in breast cancer. *Lancet* 344:1444
- Su LN, Little JB (1992) Transformation and radiosensitivity of human diploid skin fibroblasts transfected with activated *ras* oncogene and SV40 T-antigen. *Int J Radiat Biol* 62:201-210
- Swift M, Reitnaur PJ, Morrell D, Chase CL (1987) Breast and other cancers in families with ataxia-telangiectasia. *N Engl J Med* 316:1289-1294
- Taylor AMR (1983) The effect of radiation on the chromosomes of patients with an unusual cancer susceptibility. In: Ishihar T, Sasaki M (eds) Radiation induced chromosome damage in man. Alan R Liss, New York, pp 167-199
- Taylor AM, Harnden DG, Arlett CF, Harcourt SA, Lehmann AR, Stevens S, Bridges BA (1975) Ataxia-telangiectasia: a human mutation with abnormal radiation sensitivity. *Nature* 258:427-429
- Teare MD, Wallace SA, Harris M, Howell A, Birch JM (1994) Cancer experience in the relatives of an unselected series of breast cancer patients. *Br J Cancer* 10:102-111
- Thompson EA, Cannings C (1979) Sampling schemes and ascertainment. In: Sing CF, Skolnick (eds) The genetic analysis of common diseases: applications to predictive factors in coronary heart disease. Alan Liss, New York
- Varley JM, Evans DER, Birch JM (1997) Li-Fraumeni syndrome—a molecular and clinical review. *Br J Cancer* 76:1-14