

Available online at www.sciencedirect.com**ScienceDirect**

Procedia Computer Science 48 (2015) 769 – 775

Procedia
Computer Science

International Conference on Intelligent Computing, Communication & Convergence
(ICCC-2015)

Conference Organized by Interscience Institute of Management and Technology,
Bhubaneswar, Odisha, India

An approach to Image Compression by using Sparse Approximation Technique

Nibedita Pati^{a,*}, Annapurna Pradhan^a, Lalit Kumar Kanoje^a, Tanmaya Kumar Das^a

^a*Department of Electronics and Telecommunication Engineering,
Trident Academy of Technology, Bhubaneswar, India, Odisha-751024
Email: nibedita.tech2007@gmail.com*

Abstract

Image compression has been a widely researched field for decades. Recently, there has been a growing interest in using basis selection algorithms for signal approximation and compression. Signal approximation using a linear combination of basis from an over-complete dictionary has proven to be an NP-hard problem. By selecting a smaller number of basis than the span of the signal, we achieve glossy compression in exchange for a small reconstruction error. For the past few decades orthogonal and bi-orthogonal complete dictionaries such as Discrete Cosine Transform (DCT) or wavelets were the dominant transform domain representations of signals. Over-complete dictionaries have been intensively studied and successfully applied to various application such as image de-noising, compression etc. The DCT and wavelet based compression methods suffer from blocking and ringing artefacts and also they are unable to capture the directional information. So, in this context an investigation has been made by using sparse coding method by Orthogonal Matching Pursuit (OMP) algorithm. In this proposed work, conventional DCT can be replaced by a set of trained dictionaries. For dictionary construction we have used a combination of DCT and Gabor basis and to encode the trained dictionary elements we have employed OMP algorithm. Experimental results demonstrate that the proposed method provides gains in Rate Distortion (RD) performance and improvements in perceptual quality.

© 2015 The Authors. Published by Elsevier B.V. This is an open access article under the CC BY-NC-ND license (<http://creativecommons.org/licenses/by-nc-nd/4.0/>).

Peer-review under responsibility of scientific committee of International Conference on Computer, Communication and Convergence (ICCC 2015)

Keywords: Discrete Cosine Transform; Sparse Coding; Orthogonal Matching Pursuit; Over-complete dictionary.

1. Introduction

Image compression has become a necessity due to the increasing demand on data transfer and storage. Compression in general, is either lossless (original data can be totally recovered after decomposition) or lossy (data-compression techniques in which some amount of original data is lost forever). Lossy data compression has received significant attention from the research community due to its potential to achieve higher compression ratio (CR) [1].

* Corresponding author. *Email address: nibedita.tech2007@gmail.com*

For the past few decades, orthogonal and bi-orthogonal complete dictionaries such as the Discrete Cosine Transform (DCT) or wavelets were the dominant transform domain representations of image [2],[3]. Recently sparse and redundant representations of signals using over-complete dictionaries have been intensively studied and successfully applied to various applications such as image de-noising, time series analysis, compression, indexing, compressed sensing, audio source separation, etc. The aim of this work is to develop a dictionary based hybrid image compression framework with static construction of over-complete dictionary [4]. The training is done off-line and a combination of static dictionary is used to train the dictionary. The dictionary elements are trained by using the neighboring blocks of an image and for encoding the signals, we have employed Orthogonal Matching Pursuit (OMP). In this proposed algorithm, the conventional DCT can be replaced by the dictionary based approach.

2. Related research in past sparse coding

Research works had been carried out by several authors for improving image compression using sparse approximation technique. Mallat and Zhang [4] introduced the popular algorithm of this technique, the Matching Pursuit algorithm as a greedy algorithm for time frequency analysis. The basic problem is to find a set of elements called as atoms from an over-complete dictionary, whose linear combination will efficiently approximate the given signal [5]. This problem is a NP-hard problem. An image representation can be achieved using matching pursuit while retaining the important local properties like localization, scale, preferred orientation, amplitude and phase of discontinuity. For this purpose Mallat et al. constructed an extremely redundant dictionary of oriented Gabor functions and were able to represent the image in a compact form which could be used as input in sophisticated high level processing. In [6] the author suggests that optimization of the cost or bit rate associated with the selected vectors rather than the number of vectors that are selected. Performance is achieved when the selected vectors can be coded using the shortest code. It was applied to transform based coding (DCT) and fractal coding. Liu et al. [7] proposed that the size of the dictionary should be determined such that it minimizes the number of bits required to represent the approximation of the input image. When we decompose a signal using matching pursuit we store the coefficients and the indices of the elements. Thus a dictionary of larger size will require more bits to represent the indices. In [8] the authors provide with a formula that determines the optimal number of elements of the dictionary and the optimal quantization step that will reduce the number of bits required to store the matching pursuit representation to the minimum, considering the upper bound of error.

3. Proposed Methodology for the optimized sparse Model

The detailed description of the theoretical foundation of the sparse approximation technique is discussed in a sequel. Here we discuss the details of sparse approximation, the algorithms of this technique, matching pursuit and orthogonal matching pursuit and the proposed model.

3.1. Sparse Approximation

Spare coding in a redundant basis is of considerable interest in many areas of signal processing [9]. The problem generally involves solving an under-determined system of equations under a sparsely constraint. Except for the exhaustive combinatorial approach, there is no known method to find the exact solution for general dictionaries. Among the various algorithms that find approximate solutions, pursuit algorithms are the most well-known (matching pursuit and orthogonal matching pursuit) algorithm[10]. Sparse coding in a redundant basis has attracted

considerable interest recently because of its application in many areas of signal processing such as compression, denoising, time-frequency analysis, indexing, compressed sensing, audio source separation etc[11]. The basic problem is to represent a given signal, as a linear combination of the fewest signals from a redundant signal set either exactly or with some acceptable error.

Consider a set of N signal vectors arranged as the columns of a matrix A. Each vector has dimension K where $K < N$. Using the terminology in sparse approximation theory, we will refer to these vectors as atoms and to A as the dictionary matrix. We will assume that the atoms are normalized, i.e. they have magnitudes of unity. Given a signal b, the problem is to identify the fewest atoms whose linear sum will represent b and mathematically this can be formulated as solving the following system of linear equations:

$$Ax = b \tag{1}$$

Such that 'x' has the minimum number of non-zero elements. The dictionary 'A' is a fat matrix in which

$$\#columns \gg \#rows \tag{2}$$

It is a redundant basis. Each vector in the matrix is called an atom, which are normalized and have a magnitude of unity. The sparse representation problem is thus posed as

$$Min \|x\|_0 : Ax = b \tag{3}$$

Here $\|\cdot\|_0$ denotes l_0 norm which represent the number of non-zero elements. The sparse approximation problem that allows some approximation error is posed as

$$Min \|x\|_0 : \|Ax - b\|_2 \leq d \tag{4}$$

for some $d > 0$. Here $\|\cdot\|_2$ denotes the l_2 norm.

3.2. Matching Pursuit

The matching pursuit algorithm solves the problem of decomposing a given signal over a redundant dictionary of atoms whose linear combination will produce an approximation of the image [12]. The smallest possible dictionary will be the basis.

Using this algorithm finding an exact solution requires an exhaustive combinatorial approach. So this algorithm uses a greedy approach to find the sub-optimal approximation. The algorithm works as described below.

Let $a_i, 1 \leq i \leq N$, denote the i^{th} column of the dictionary matrix A. At the j^{th} iteration $j=1,2,\dots$ the algorithm finds

$$Atom_j = \arg \max | \langle r_{j-1}, a_j \rangle | \tag{5}$$

Where A denoted the dictionary of atoms, r_{j-1} denotes the approximation error or residual at the (j-1) iteration, and $\langle \cdot, \cdot \rangle$ denotes the inner-product operation defined as $\langle u, v \rangle = u^T v$. **This is the atom selection step.**

At the start of the iteration, the approximation error is equal to the given vector and hence $r_0 = b$. The weight or coefficient of the selected atom, is $\langle r_{j-1}, atom_j \rangle$ and let us denote it as c_j . The algorithm then updates the residual as

$$r_j = r_{j-1} - c_j \cdot atom_j \tag{6}$$

This is the residual update step. So, we will send the decoder a combination of (c,p) where c is the coefficient value and p is the position. After some iteration the algorithm terminates if the norm of the residual falls below a desired approximation error bound or if the number of distinct atoms in the approximation equals a desired limit.

3.3. Orthogonal Matching Pursuit

In matching pursuit, the orthogonalization of the residual with respect to each newly selected library member can introduce components of previously selected library members into the residual [14]. To avoid this problem, at each stage, instead of finding the new residual vector by orthogonalizing the old residual with respect to the newly selected library vector, we can orthogonalize with respect to all the selected library vectors so far. The new residual generated this way is orthogonal to all previously selected library vectors and is therefore equal to the residual after finding the least squares solution using all the selected library vectors.

3.4. Proposed Compression Scheme

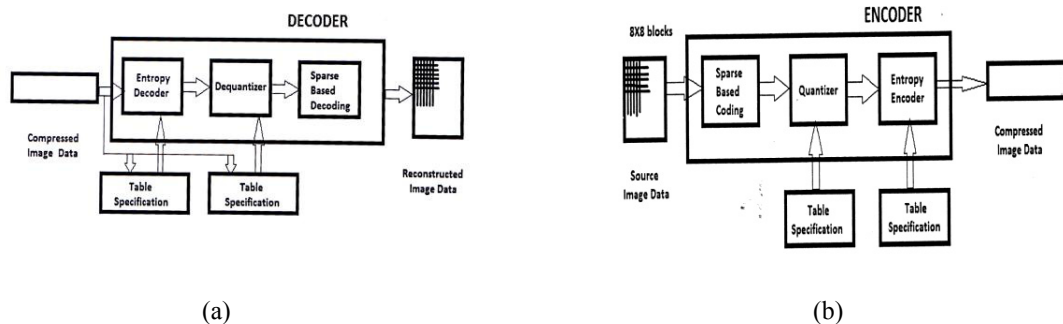

Fig. 1. Block diagram of the (a) encoder of the proposed model (b) decoder of the proposed model

In sparse approximation technique, the problem is to represent the input image using minimum number of atoms from an over-complete dictionary. This model generates representations of very large size. Instead of decomposing a given image over this whole set of Gabor functions, we use an adaptive algorithm called Matching Pursuit to select the Gabor elements which approximate at best the image, corresponding to the main features of the images. The Gabor functions take into account the directional features of the image. Image decompositions in families of Gabor functions characterize the local scale, orientation and phase of the image variations. Thus a dictionary designed from the combination of DCT and Gabor transform will consider the vertical, horizontal as well as the directional components if any in the given image. The overall steps of the approach are discussed in a sequel.

Steps:

1. Take the non-overlapping 8X8 blocks of an image.
2. Train the 8X8 blocks of an image with the proposed static based dictionary.
3. The dictionary elements are selected by the OMP algorithm.
4. After the selection of the dictionary elements, the coefficients are quantized and entropy encoded as shown in Fig.1.
5. A uniform quantizer is adapted in the proposed algorithm. In an entropy coder the coefficients are converted to binary by Huffman coding table based on the statistics.
6. The indices are encoded with the fixed length code whose size $\log_2 [m]$ where m is the number of elements in the dictionary.
7. For reconstruction, same process has been adopted as the encoder i.e. the indices specify which dictionary elements to use.

4. Proposed Methodology for the optimized sparse Model

In order to evaluate the efficiency of proposed scheme different standard images such as “peppers”, “football”, and “Gantrycrane” etc. are taken in the experiment. In the experiment four schemes i.e. JPEG, JPEG2000, DCT-

based image compression scheme, HAAR-based image compression scheme along with the proposed scheme were implemented on AMD Dual core Turion 64X2 TL-56, 1.8GHz personal computer with 2GB memory using MATLAB. The images used during our experiments are of 256 X 256 pixels with 8bit gray level.

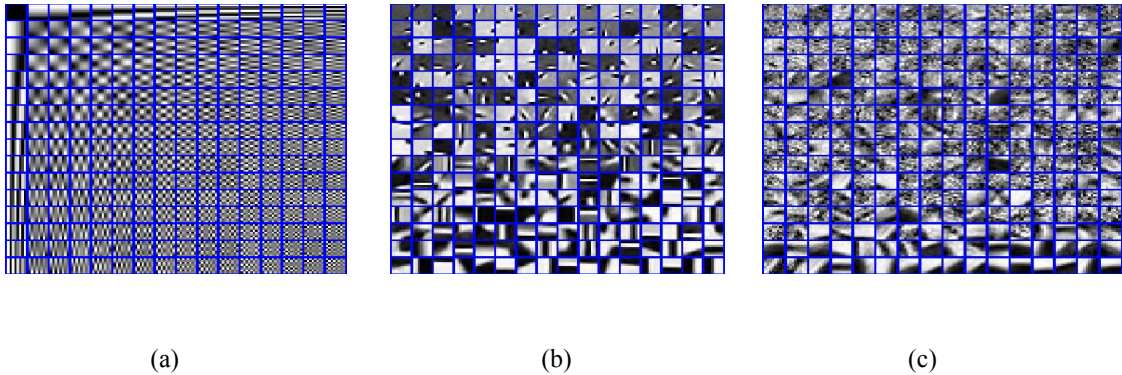

Fig. 2. (a) Over-complete DCT-based Dictionary (b) Over-complete HAAR-based Dictionary (c) Over-complete Dictionary for Proposed Model

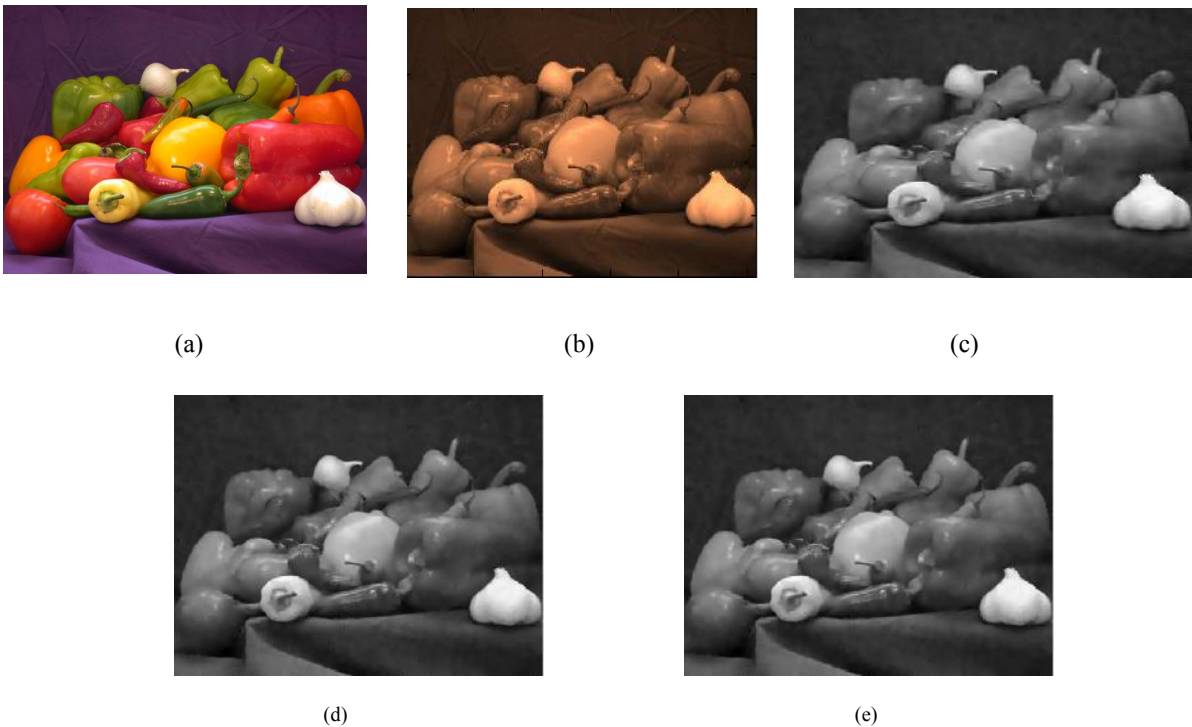

Fig. 3. (a) Image for JPEG(peppers.png) (b) Image for JPEG 2000(peppers.png) (c) Image for Over-complete DCT Dictionary(peppers.png) (d) Image for Over –complete HAAR Dictionary (peppers.png) (e) image for Over –complete Dictionary for proposed model(peppers.png)

In the experiment, the over-complete proposed dictionaries are trained with several standard image such as “peppers”, “football”, and “Gantrycrane”. During the testing the standard image like lena, cameraman etc. are taken which are not considered during training. The size of the dictionary of the proposed scheme is 64 x128. The over-complete dictionary constructed for the DCT-based over-complete dictionary image coding scheme, HAAR

based over-complete dictionary image coding scheme and the proposed scheme are shown in Fig. 2. Fig.3. shows the reconstructed image of JPEG, JPEG 2000, DCT dictionary, HAAR dictionary and the proposed scheme for the image peppers.png. Table 1 shows the PSNR(in dB) obtained for various images tested for different schemes which shows improvement in the proposed model. Fig. 4 shows that Bitrate vs. PSNR(in dB) of the proposed scheme as compared to JPEG, JPEG 2000, DCT dictionary and HAAR dictionary. The proposed algorithm yields 3.5dB, 0.5dB, 0.4dB and 0.7dB PSNR gain as compared to JPEG, JPEG 2000, DCT based dictionary and HAAR based dictionary image coding scheme for the peppers.png image as shown in the fig. 4.

Table 1. PSNR (in dB) obtained for different standard images

Standard Image Names	JPEG	JPEG 2000	DCT Dictionary	HAAR Dictionary	Proposed Model
Pepper	37.128	40.423	40.453	40.134	40.752
Football	34.634	35.288	36.004	36.555	36.876
Gantrycrane	36.655	38.144	39.245	41.367	41.566

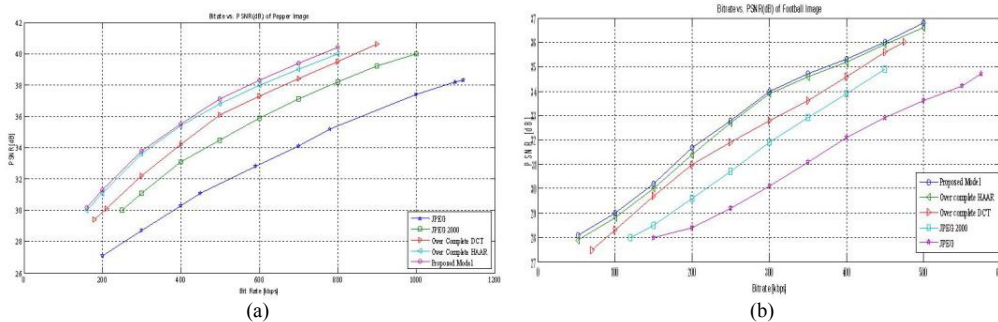

Fig. 4. (a) Bitrate vs. PSNR (in dB) of Pepper Image (b) Bitrate vs. PSNR (in dB) of Football Image

5. Conclusion

In this paper we propose an efficient over-complete static dictionary for image compression aspect. The proposed algorithm trains the static over-complete dictionary with combination of DCT and Gabor basis. The dictionary elements are trained using OMP algorithm. Experimental result shows that the proposed dictionary based image coding shows significant PSNR gains as compared to the existing scheme. There can be further modification in the dictionary with incorporation of new feature by using KSVD algorithm which uses adaptive dictionary.

References

- Gregory K. Wallace, "The JPEG still picture compression standard", IEEE transactions on Consumer Electronics, December 1991.
- Ali Bilgin, Michael W. Marcellin and Maria I. Altbach, "Compression of Electrocardiogram Signal using JPEG 2000", IEEE Transaction on Consumer Electronics (ICIP), 2003.
- Anjali Kapoor and Renu Dhi. "Image Compression Using Fast 2-D DCT Technique", International Journal on computer Science and Engineering (IJCS), ISSN: 0975-3397, Vol. 3, No.6, June 2011.
- S. Mallat and Z. Zhang, "Matching pursuits with time frequency dictionaries", IEEE trans. Signal Process., Vol.41, No.12, pp.3397-3415, Dec.1993.
- G. Rath, C.Guillemot, "Complimentary Matching pursuits Algorithms for sparse Approximation", Journal of Signal Processing, pp.702-706, January 2009.
- Francois Bergeaud and Stephane Mallat, "Matching pursuits of Images", IEEE 1995.
- Qiangsheng Liu, Qiao Wang and Lenan Wce, "Size of the Dictionary in Matching Pursuit Algorithm", IEEE 2004
- Tao Gan, Yanmin He and Weile Zhu. "Sparse Approximation using Fast Matching pursuit", IEEE 2005.
- B. K. Natarajan, "Sparse Approximation solution to linear systems", SIAMJ, Vol.24, No.2, pp.227-234, Apr.1995.
- Y.C.Pati, R. Rezaifar and P. S. Krishnaprasad, "Orthogonal Matching pursuit: Recursive function approximation with application to wavelet decomposition", Proc. 27th Conf. On Sig. sys. And Comp., Vol.1, Nov 1993.
- G.Davis, S.Mallat and Z.Zhang, "Adaptive time frequency decomposition with Matching pursuit", Proc. SPIE, Wavelet application, H.H.Szu, Vol. 2242, pp.402-413.

12. I.F.Gorodnitsky and B.D. Rao, “Sparse signal reconstruction for limited data using focus:a re-weighted minimum norm algorithm”, IEEE Transaction on Signal Processing ,Vol.45,No.3, pp. 600-616, March 1997.
13. B.A.Olshausen and D.J.Field , “Sparse coding with an over – complete basis set: a strategy employed by VI”, Vol.47, pp.3311-3325,1997.
14. D.L. Donoho, Y. Tsaig, I. Drori and J.L.Starck, “Sparse solution of underdetermined linear equations by stage wise orthogonal matching pursuit”, March 2006.