

Available online at www.sciencedirect.com**SciVerse ScienceDirect**

Advances in Mathematics 231 (2012) 1–42

**ADVANCES IN
Mathematics**

www.elsevier.com/locate/aim

On representation categories of wreath products in non-integral rank

Masaki Mori

Graduate School of Mathematical Sciences, The University of Tokyo, Tokyo 153, Japan

Received 27 September 2011; accepted 3 May 2012

Available online 28 May 2012

Communicated by Roman Bezrukavnikov

Abstract

For an arbitrary commutative ring k and $t \in k$, we construct a 2-functor \mathcal{S}_t which sends a tensor category to a new tensor category. By applying it to the representation category of a bialgebra we obtain a family of categories which interpolates the representation categories of the wreath products of the bialgebra. This generalizes the construction of Deligne's category $\text{Rep}(S_t, k)$ for representation categories of symmetric groups.

© 2012 Elsevier Inc. All rights reserved.

Keywords: Tensor categories; Deligne's category; Partition algebras

1. Introduction

Let k be a commutative ring. In [5], Deligne introduced a tensor category $\text{Rep}(S_t, k)$ for an arbitrary $t \in k$, “the category of representations of the symmetric group of rank t over k ” in some sense. This category is consisting of objects which imitate some classes of representations of the symmetric group of indefinite rank. If the rank t is a natural number, the usual representation category of the symmetric group will be restored by taking a quotient of Deligne's category.

Generalizations of Deligne's category are considered by many authors, e.g. Knop [10,11], Etingof [6] and Mathew [16]. In this paper we give another generalization: we extend Deligne's construction to a 2-functor \mathcal{S}_t which sends a tensor category to another tensor category. In other words, for each tensor category \mathcal{C} the 2-functor \mathcal{S}_t provides a new tensor category $\mathcal{S}_t(\mathcal{C})$.

E-mail address: mori@ms.u-tokyo.ac.jp.

Using this 2-functor, Deligne’s category is obtained by applying it to the trivial tensor category consisting of only one object. Moreover if we apply \mathcal{S}_t to a representation category of some bialgebra, we will get a family of new tensor categories which interpolates the representation categories of the wreath products of the bialgebra. For a finite group G , Knop’s interpolation $\text{Rep}(G \wr \mathcal{S}_t, k)$ is essentially the same as ours but in general either construction does not include the other. For example, in Knop’s category $\mathcal{T}(\mathcal{A}, \delta)$, the tensor product is always symmetric and every object has its dual; however our $\mathcal{S}_t(\mathcal{C})$ satisfies neither of them unless the base category \mathcal{C} does.

The 2-functor \mathcal{S}_t naturally preserves various structures of categories such as duals, braidings (symmetric or not), twists, traces and so on (see the [Appendix](#)). In particular, if \mathcal{C} is a braided tensor category then so is $\mathcal{S}_t(\mathcal{C})$. In this case, we can represent and calculate morphisms in $\mathcal{S}_t(\mathcal{C})$ by string diagrams. These diagrams are generalizations of those used for partition algebras [9,15] and can be regarded as “ \mathcal{C} -colored” variants of them. For example, there is a morphism in $\mathcal{S}_t(\mathcal{C})$ represented by a diagram

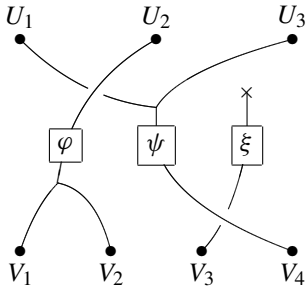

where $U_1, U_2, U_3, V_1, V_2, V_3$ and V_4 are objects of \mathcal{C} and φ, ψ and ξ are suitable morphisms in \mathcal{C} . Composition of such morphisms is expressed by vertical connection of diagrams and tensor product by horizontal arrangement. By [Theorem 4.31](#) we also prove that $\mathcal{S}_t(\mathcal{C})$ can be described in terms of generators (i.e. pieces of diagrams) and relations (i.e. local transformation of diagrams). In fact it has a universal property which says that it is the smallest braided tensor category which satisfies these relations. Its generators and the relations are listed in [Proposition 4.26](#).

In the rest of the paper we extend the result of Comes and Ostrik [3] which describes the structure of Deligne’s category. Assume that k is a field of characteristic zero and let \mathcal{C} be an abelian semisimple tensor category whose every simple object U satisfies $\text{End}_{\mathcal{C}}(U) \simeq k$. In this case, we can completely describe the structure of the category $\mathcal{S}_t(\mathcal{C})$; we classify the indecomposable objects, simple objects and blocks. We parameterize them using sequences of Young diagrams indexed by the simple objects of \mathcal{C} . See [Theorem 5.6](#) for details. In fact, ignoring the structure of tensor product, this category is equivalent to the direct sum of some copies of Deligne’s category $\text{Rep}(\mathcal{S}_{t-m}, k)$ as $m \in \mathbb{N}$ varies. In particular, if $t \notin \mathbb{N}$ then $\mathcal{S}_t(\mathcal{C})$ is also abelian semisimple and we can produce a large number of new abelian semisimple tensor categories which cannot be realized as representation category of algebraic structure.

1.1. Conventions and notations

In this paper, a ring means an associative ring with unit and ring homomorphisms preserve the unit. A module over a ring is always a left module and unital. We use the symbol k to denote a commutative ring and for k -modules U and V , we write $U \otimes V$ instead of $U \otimes_k V$ for short.

For a category \mathcal{C} the notation $U \in \mathcal{C}$ means that U is an object of \mathcal{C} . For $U, V \in \mathcal{C}$, we denote by $\text{Hom}_{\mathcal{C}}(U, V)$ the set of morphisms from U to V . If $U = V$ we also denote it by $\text{End}_{\mathcal{C}}(U)$. For a natural transformation $\eta: F \rightarrow G$ between two functors $F, G: \mathcal{C} \rightarrow \mathcal{D}$, we denote its component at an object $U \in \mathcal{C}$ by $\eta(U): F(U) \rightarrow G(U)$. We do not ask the meanings of the terms “small” and “large” about sizes of categories; some readers may interpret them with class theory while others prefer to use Grothendieck universes.

We include zero in the set of natural numbers, so $\mathbb{N} = \{0, 1, 2, \dots\}$.

2. The language of linear categories

In this section we quickly review the theory of linear categories.

2.1. Definition and properties

- Definition 2.1.** (1) A category \mathcal{C} is called a *k-linear category* if for each objects $U, V \in \mathcal{C}$, $\text{Hom}_{\mathcal{C}}(U, V)$ is endowed with a structure of k -module and the composition of morphisms is k -bilinear.
- (2) A functor $F: \mathcal{C} \rightarrow \mathcal{D}$ between two k -linear categories is called *k-linear* if for any $U, V \in \mathcal{C}$ the map $F: \text{Hom}_{\mathcal{C}}(U, V) \rightarrow \text{Hom}_{\mathcal{D}}(F(U), F(V))$ is k -linear. We define *k-multilinear functor* in the same way.
- (3) A *k-linear transformation* is just a natural transformation between two k -linear functors.

Some authors call a k -linear category a *k-preadditive category* or a *k-category*. These below are examples of k -linear categories which we use later.

- Definition 2.2.** (1) We denote by $\mathcal{T}riv_k$ the *trivial k-linear category* consisting of a single object $\mathbb{1} \in \mathcal{T}riv_k$ which satisfies $\text{End}_{\mathcal{T}riv_k}(\mathbb{1}) \simeq k$.
- (2) For a k -algebra A , we denote by $\text{Mod}(A)$ the category consisting of A -modules and A -homomorphisms, and $\text{Rep}(A)$ the full subcategory of $\text{Mod}(A)$ consisting of A -modules which are finitely generated and projective over k .
- (3) For two k -linear categories \mathcal{C} and \mathcal{D} , we denote by $\text{Hom}_k(\mathcal{C}, \mathcal{D})$ the category consisting of k -linear functors from \mathcal{C} to \mathcal{D} and k -linear transformations between them.

In a k -linear category finite product and finite coproduct coincide and both are called direct sum. k -linear functors and transformations are automatically compatible with taking direct sum.

Definition 2.3. Let \mathcal{C} be a k -linear category.

- (1) \mathcal{C} is called *additive* if for any $U_1, \dots, U_m \in \mathcal{C}$ there exists their direct sum $U_1 \oplus \dots \oplus U_m \in \mathcal{C}$ (including zero object for $m = 0$).
- (2) \mathcal{C} is called *Karoubian* (or *idempotent complete*) if for any $U \in \mathcal{C}$ and any idempotent $e = e^2 \in \text{End}_{\mathcal{C}}(U)$ there exists its image $eU \in \mathcal{C}$. In other words, \mathcal{C} is Karoubian if every idempotent $e \in \text{End}_{\mathcal{C}}(U)$ admits a direct sum decomposition $U \simeq eU \oplus (1 - e)U$.
- (3) \mathcal{C} is called *pseudo-abelian* if it is additive and Karoubian.

For example, $\text{Mod}(A)$ and $\text{Rep}(A)$ are both pseudo-abelian k -linear categories. The category $\text{Hom}_k(\mathcal{C}, \mathcal{D})$ of k -linear functors is additive or Karoubian if the target category \mathcal{D} is.

Definition 2.4. A k -linear category \mathcal{C} is called *hom-finite* (resp. *projective*) if $\text{Hom}_{\mathcal{C}}(U, V)$ is finitely generated (resp. projective) over k for every $U, V \in \mathcal{C}$.

For example, $\mathcal{R}ep(k)$ is clearly hom-finite and projective. If k is Noetherian $\mathcal{R}ep(A)$ is also hom-finite for any k -algebra A since $Hom_A(U, V) \subset Hom_k(U, V)$. Similarly if k is a hereditary ring $\mathcal{R}ep(A)$ is automatically projective.

Definition 2.5. Let \mathcal{C} be a pseudo-abelian k -linear category. An *indecomposable object* in \mathcal{C} is an object U such that $U \simeq U_1 \oplus U_2$ implies either $U_1 \simeq 0$ or $U_2 \simeq 0$. \mathcal{C} is called a *Krull–Schmidt category* if it satisfies the following two conditions:

- (1) every object in \mathcal{C} is a finite direct sum of indecomposable objects,
- (2) the endomorphism ring of each indecomposable object in \mathcal{C} is a local ring.

It is clear that every hom-finite pseudo-abelian linear category over a field is a Krull–Schmidt category. In such a category, the factors in the indecomposable decomposition of an object is uniquely determined.

Theorem 2.6. Let \mathcal{C} be a Krull–Schmidt category. Let $U \simeq V_1 \oplus \dots \oplus V_m \simeq W_1 \oplus \dots \oplus W_n \in \mathcal{C}$ be two decompositions of an object into indecomposable objects. Then $m = n$ and $V_i \simeq W_i$ after reordering if necessary.

This is a generalization of the usual Krull–Schmidt theorem for modules over a ring, and the proof of them are same. See e.g. [1]. So to describe the structure of a Krull–Schmidt category all we need is the classification of indecomposable objects and morphisms between them.

2.2. Envelopes

A k -linear category is not necessarily additive nor Karoubian in general; so the direct sum of objects or the image of an idempotent does not necessarily exist. But we can formally add the results of these operations into our category to make a new category including them.

Definition 2.7. Let \mathcal{C} be a k -linear category.

- (1) Define the k -linear category $Add(\mathcal{C})$ as follows:

Object A finite tuple (U_1, \dots, U_m) of objects in \mathcal{C} .

Morphism $Hom_{Add(\mathcal{C})}((U_1, \dots, U_m), (V_1, \dots, V_n)) := \bigoplus_{i,j} Hom_{\mathcal{C}}(U_i, V_j)$ and the composition of morphisms is same as the product of matrices.

We simply denote $(U) \in Add(\mathcal{C})$ by U , then $(U_1, \dots, U_m) \simeq U_1 \oplus \dots \oplus U_m$ and the empty tuple $()$ is a zero object. $Add(\mathcal{C})$ is called the *additive envelope* of \mathcal{C} .

- (2) Define the k -linear category $Kar(\mathcal{C})$ as follows:

Object A pair (U, e) of an object $U \in \mathcal{C}$ and an idempotent $e = e^2 \in End_{\mathcal{C}}(U)$.

Morphism $Hom_{Kar(\mathcal{C})}((U, e), (V, f)) := f \circ Hom_{\mathcal{C}}(U, V) \circ e$.

We denote $(U, id_U) \in Kar(\mathcal{C})$ by U , then $(U, e) \simeq eU$. $Kar(\mathcal{C})$ is called the *Karoubian envelope* (or the *idempotent completion*) of \mathcal{C} .

- (3) $\mathcal{P}s(\mathcal{C}) := Kar(Add(\mathcal{C}))$ is called the *pseudo-abelian envelope* of \mathcal{C} .

Clearly $Add(\mathcal{C})$ is additive and $Kar(\mathcal{C})$ is Karoubian. $\mathcal{P}s(\mathcal{C})$ is pseudo-abelian since $Kar(\mathcal{C})$ is additive when \mathcal{C} is: $(U, e) \oplus (V, f) \simeq (U \oplus V, e \oplus f)$. The base category \mathcal{C} is embedded in $Add(\mathcal{C})$ (resp. $Kar(\mathcal{C})$, $\mathcal{P}s(\mathcal{C})$) as a full subcategory and this embedding is a category equivalence if and only if \mathcal{C} is additive (resp. Karoubian, pseudo-abelian).

Example 2.8.

$Add(Triv_k) \simeq$ (The category of finitely generated free k -modules),
 $\mathcal{P}_s(Triv_k) \simeq$ (The category of finitely generated projective k -modules)
 $= Rep(k)$.

To describe the universal properties of the operation \mathcal{P}_s we should use the notions of 2-categories and 2-functors. For their definitions, see e.g. [13]. Let us denote by \mathbf{Cat}_k the 2-category consisting of (small) k -linear categories, functors and transformations, and by \mathbf{PsCat}_k the full sub-2-category of \mathbf{Cat}_k consisting of pseudo-abelian k -linear categories. For a k -linear functor $F: \mathcal{C} \rightarrow \mathcal{D}$, we can extend it to the functor $\mathcal{P}_s(F): \mathcal{P}_s(\mathcal{C}) \rightarrow \mathcal{P}_s(\mathcal{D})$ between the envelopes in the obvious manner. Moreover, for a k -linear transformation $\eta: F \rightarrow G$ we can also define the transformation $\mathcal{P}_s(\eta): \mathcal{P}_s(F) \rightarrow \mathcal{P}_s(G)$. So the operation $\mathcal{P}_s: \mathbf{Cat}_k \rightarrow \mathbf{PsCat}_k$ is actually a 2-functor between these 2-categories. This is the left adjoint of the embedding $\mathbf{PsCat}_k \hookrightarrow \mathbf{Cat}_k$ in the 2-categorical sense; that is, if \mathcal{D} is pseudo-abelian then the restriction of functors induces a category equivalence

$$Hom_k(\mathcal{P}_s(\mathcal{C}), \mathcal{D}) \xrightarrow{\sim} Hom_k(\mathcal{C}, \mathcal{D}).$$

We say a pseudo-abelian k -linear category \mathcal{C} is generated by a full subcategory $\mathcal{C}' \subset \mathcal{C}$ if every object in \mathcal{C} is isomorphic to some direct summand of a direct sum of objects in \mathcal{C}' , or equivalently, $\mathcal{P}_s(\mathcal{C}') \simeq \mathcal{C}$. When this condition is satisfied we also say objects in \mathcal{C}' generate \mathcal{C} .

2.3. Tensor categories

A tensor category is a kind of generalization of categories which have binary “product”, associative and unital up to isomorphism, such as the category of vector spaces with tensor product.

Definition 2.9. (1) A k -tensor category is a k -linear category \mathcal{C} equipped with a k -bilinear functor $\otimes: \mathcal{C} \times \mathcal{C} \rightarrow \mathcal{C}$ called the tensor product and a functorial isomorphism $\alpha_{\mathcal{C}}$ called the associativity constraint with components $\alpha_{\mathcal{C}}(U, V, W): (U \otimes V) \otimes W \xrightarrow{\sim} U \otimes (V \otimes W)$ such that the diagram below commutes:

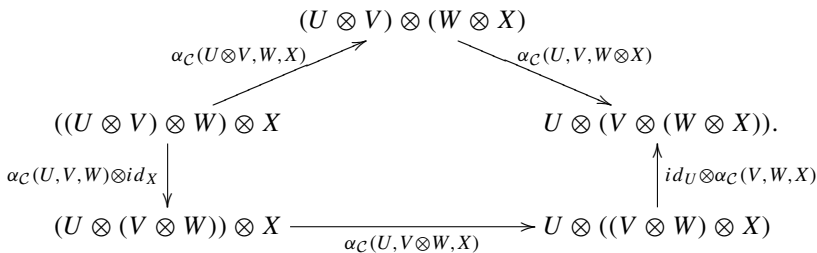

(2) A unit object of a k -tensor category \mathcal{C} is an object $\mathbb{1}_{\mathcal{C}} \in \mathcal{C}$ equipped with two functorial isomorphisms $\lambda_{\mathcal{C}}(U): \mathbb{1}_{\mathcal{C}} \otimes U \xrightarrow{\sim} U$ and $\rho_{\mathcal{C}}(U): U \otimes \mathbb{1}_{\mathcal{C}} \xrightarrow{\sim} U$ called the unit constraints

such that the diagram below commutes:

$$\begin{array}{ccc}
 (U \otimes \mathbb{1}_{\mathcal{C}}) \otimes V & \xrightarrow{\alpha_{\mathcal{C}}(U, \mathbb{1}_{\mathcal{C}}, V)} & U \otimes (\mathbb{1}_{\mathcal{C}} \otimes V) \\
 \searrow \rho_{\mathcal{C}}(U) \otimes id_V & & \swarrow id_U \otimes \lambda_{\mathcal{C}}(V) \\
 & U \otimes V. &
 \end{array}$$

Since the equality $(U \otimes V) \otimes W = U \otimes (V \otimes W)$ is too strict in category theory, we need a functorial isomorphism instead. However, Mac Lane’s coherence theorem [14] allows us to define the m -fold tensor product $U_1 \otimes \cdots \otimes U_m$ for multiple objects $U_1, \dots, U_m \in \mathcal{C}$ since it does not depend on the order of taking tensor product up to a unique isomorphism. Similarly for an object $U_1 \otimes \cdots \otimes U_m$ we can freely insert or remove tensor products of unit objects.

Remark that a unit object is unique up to a unique isomorphism if exists. If \mathcal{C} has a unit object $\mathbb{1}_{\mathcal{C}}$ then $End_{\mathcal{C}}(\mathbb{1}_{\mathcal{C}})$ is also a commutative ring and \mathcal{C} has two (possibly different) structures of $End_{\mathcal{C}}(\mathbb{1}_{\mathcal{C}})$ -linear category induced by $\lambda_{\mathcal{C}}$ and $\rho_{\mathcal{C}}$.

Assumption 2.10. In this paper we do not treat tensor categories without units. We always assume that each k -tensor category \mathcal{C} is endowed with a fixed unit object $\mathbb{1}_{\mathcal{C}} \in \mathcal{C}$. In addition, we require that the unit object $\mathbb{1}_{\mathcal{C}}$ satisfies $End_{\mathcal{C}}(\mathbb{1}_{\mathcal{C}}) \simeq k$.

In the rest of this paper, we omit writing the isomorphisms $\alpha_{\mathcal{C}}$, $\lambda_{\mathcal{C}}$ and $\rho_{\mathcal{C}}$ explicitly for a k -tensor category \mathcal{C} since the reader can complete them easily if needed.

Example 2.11. $Triv_k$ has the unique structure of k -tensor category. $Mod(k)$ and $Rep(k)$ are k -tensor categories with usual tensor products of modules. More generally, for a bialgebra A over k , the k -linear categories $Mod(A)$ and $Rep(A)$ have structures of k -tensor category. For A -modules U and V , the k -module $U \otimes V$ becomes an A -module via the coproduct of A , $\Delta_A : A \rightarrow A \otimes A$. The unit object $\mathbb{1}_A$ is defined to be k as a k -module and the action of A is the scalar multiplication by the counit of A , $\epsilon_A : A \rightarrow k$.

Next we define the corresponding structures on functors and transformations. Again we need functorial isomorphisms to avoid using equations.

Definition 2.12. (1) A k -tensor functor $F : \mathcal{C} \rightarrow \mathcal{D}$ between k -tensor categories is a k -linear functor equipped with functorial isomorphisms $\mu_F(U, V) : F(U) \otimes F(V) \xrightarrow{\sim} F(U \otimes V)$ and $\iota_F : \mathbb{1}_{\mathcal{D}} \xrightarrow{\sim} F(\mathbb{1}_{\mathcal{C}})$ such that the diagrams below commute:

$$\begin{array}{ccc}
 F(U) \otimes F(V) \otimes F(W) & \xrightarrow{id_{F(U)} \otimes \mu_F(V, W)} & F(U) \otimes F(V \otimes W) \\
 \mu_F(U, V) \otimes id_{F(W)} \downarrow & & \downarrow \mu_F(U, V \otimes W) \\
 F(U \otimes V) \otimes F(W) & \xrightarrow{\mu_F(U \otimes V, W)} & F(U \otimes V \otimes W), \\
 \\
 F(U) & \xrightarrow{id_{F(U)} \otimes \iota_F} & F(U) \otimes F(\mathbb{1}_{\mathcal{C}}) \\
 \iota_F \otimes id_{F(U)} \downarrow & \searrow & \downarrow \mu_F(U, \mathbb{1}_{\mathcal{C}}) \\
 F(\mathbb{1}_{\mathcal{C}}) \otimes F(U) & \xrightarrow{\mu_F(\mathbb{1}_{\mathcal{C}}, U)} & F(U).
 \end{array}$$

In other words, the isomorphisms μ_F and ι_F must be associative and unital.

(2) A k -tensor transformation $\eta: F \rightarrow G$ between k -tensor functors is a k -linear transformation such that the diagrams below commute:

$$\begin{array}{ccc}
 F(U) \otimes F(V) & \xrightarrow{\mu_F(U,V)} & F(U \otimes V) \\
 \eta(U) \otimes \eta(V) \downarrow & & \downarrow \eta(U \otimes V) \\
 G(U) \otimes G(V) & \xrightarrow{\mu_G(U,V)} & G(U \otimes V),
 \end{array}
 \qquad
 \begin{array}{ccc}
 \mathbb{1}_{\mathcal{D}} & \xrightarrow{\iota_F} & F(\mathbb{1}_{\mathcal{C}}) \\
 \parallel & & \downarrow \eta(\mathbb{1}_{\mathcal{C}}) \\
 \mathbb{1}_{\mathcal{D}} & \xrightarrow{\iota_G} & G(\mathbb{1}_{\mathcal{C}}).
 \end{array}$$

In other words, a k -tensor transformation η must satisfy that $\eta(U \otimes V) = \eta(U) \otimes \eta(V)$ and $\eta(\mathbb{1}_{\mathcal{C}}) = id_{\mathbb{1}_{\mathcal{D}}}$.

Beware that the category $Hom_k^{\otimes}(\mathcal{C}, \mathcal{D})$ consisting of k -tensor functors and transformations is no longer k -linear.

2.4. Braided tensor categories

A braided tensor category is a tensor category equipped with a functorial isomorphism called *braiding*, which allows us to swap two objects in a tensor product $U \otimes V$.

Definition 2.13. (1) A *braiding* (also called a *commutativity constraint*) on a k -tensor category \mathcal{C} is a functorial isomorphism $\sigma_{\mathcal{C}}(U, V): U \otimes V \xrightarrow{\sim} V \otimes U$ such that the diagrams below commute:

$$\begin{array}{ccc}
 U \otimes V \otimes W & \xrightarrow{\sigma_{\mathcal{C}}(U, V \otimes W)} & V \otimes W \otimes U, \\
 \searrow \sigma_{\mathcal{C}}(U, V) \otimes id_W & & \nearrow id_V \otimes \sigma_{\mathcal{C}}(U, W) \\
 & V \otimes U \otimes W & \\
 & \uparrow id_U \otimes \sigma_{\mathcal{C}}(V, W) & \\
 U \otimes V \otimes W & \xrightarrow{\sigma_{\mathcal{C}}(U \otimes V, W)} & W \otimes U \otimes V. \\
 & \searrow \sigma_{\mathcal{C}}(U, W) \otimes id_V & \\
 & U \otimes W \otimes V &
 \end{array}$$

The *inverse* of the braiding $\sigma_{\mathcal{C}}$ is defined by $\sigma_{\mathcal{C}}^{-1}(V, W) := \sigma_{\mathcal{C}}(W, V)^{-1}$. A braiding $\sigma_{\mathcal{C}}$ is called *symmetric* if $\sigma_{\mathcal{C}} = \sigma_{\mathcal{C}}^{-1}$.

- (2) A k -tensor category \mathcal{C} equipped with a braiding $\sigma_{\mathcal{C}}$ is called a *k -braided tensor category*. If the braiding is symmetric, we call it a *k -symmetric tensor category*.
- (3) A *k -braided tensor functor* $F: \mathcal{C} \rightarrow \mathcal{D}$ between k -braided tensor categories is a k -tensor functor such that the diagram below commutes:

$$\begin{array}{ccc}
 F(U) \otimes F(V) & \xrightarrow{\mu_F(U,V)} & F(U \otimes V) \\
 \sigma_{\mathcal{D}}(F(U), F(V)) \downarrow & & \downarrow F(\sigma_{\mathcal{C}}(U, V)) \\
 F(V) \otimes F(U) & \xrightarrow{\mu_F(V,U)} & F(V \otimes U).
 \end{array}$$

- (4) A *k -braided tensor transformation* is just a k -tensor transformation between two k -braided tensor functors.

The axiom says that the braiding $\sigma_C(U_1 \otimes \cdots \otimes U_m, V_1 \otimes \cdots \otimes V_n)$ between tensor products is determined by $\sigma_C(U_i, V_j)$ at each terms U_i and V_j . It also indicates that for each $g \in \mathfrak{B}_m$, where \mathfrak{B}_m is the braid group of order m , there is a well-defined functorial isomorphism

$$\sigma_C^g(U_1, \dots, U_m): U_1 \otimes \cdots \otimes U_m \xrightarrow{\sim} U_{g^{-1}(1)} \otimes \cdots \otimes U_{g^{-1}(m)}$$

which permutes the terms of tensor products along g using the braiding σ_C . When the braiding is symmetric then σ_C^g is well-defined for $g \in \mathfrak{S}_m$, an element of the symmetric group.

Example 2.14. If A is a cocommutative bialgebra then the transposition map $U \otimes V \xrightarrow{\sim} V \otimes U; u \otimes v \mapsto v \otimes u$ for $U, V \in \text{Mod}(A)$ is an A -homomorphism. Thus this functorial isomorphism defines a structure of k -symmetric tensor category on $\text{Mod}(A)$. On the other hand, the quantum enveloping algebra $U_q(\mathfrak{g})$ over $k = \mathbb{C}(q)$ is not cocommutative, but the category of finite dimensional \mathfrak{h} -semisimple $U_q(\mathfrak{g})$ -modules has a non-symmetric braiding introduced by an R -matrix.

3. Representation category of wreath product

Let $d \in \mathbb{N}$. For each k -algebra A , we can construct a new algebra $A \wr \mathfrak{S}_d$ called the *wreath product* of A of rank d following the two steps below:

$$A \mapsto A^{\otimes d} \mapsto A \wr \mathfrak{S}_d.$$

- (1) Create the d -fold tensor product algebra $A^{\otimes d} = A \otimes \cdots \otimes A$ from the base algebra A . Then the symmetric group \mathfrak{S}_d of rank d naturally acts on $A^{\otimes d}$ by permutation of terms.
- (2) Create the semidirect product algebra $A \wr \mathfrak{S}_d = A^{\otimes d} \rtimes \mathfrak{S}_d$ by twisting the product via the action $\mathfrak{S}_d \curvearrowright A^{\otimes d}$.

For these three algebras we have corresponding representation categories

$$\text{Rep}(A) \mapsto \text{Rep}(A^{\otimes d}) \mapsto \text{Rep}(A \wr \mathfrak{S}_d).$$

One of the remarkable facts is, under suitable conditions, that we can proceed these steps using the categorical language only and create these representation categories without the information about the base algebra A itself. This operation can be applied to an arbitrary k -linear category \mathcal{C} which is not of the form of representation category of algebra. The procedure for this construction is as follows:

$$\mathcal{C} \mapsto \mathcal{C}^{\boxtimes d} \mapsto (\mathcal{C}^{\boxtimes d})^{\mathfrak{S}_d}.$$

- (1) Create the d -fold tensor product category $\mathcal{C}^{\boxtimes d} = \mathcal{C} \boxtimes \cdots \boxtimes \mathcal{C}$ from the base category \mathcal{C} . Then the symmetric group \mathfrak{S}_d naturally acts on it.
- (2) Take the category $(\mathcal{C}^{\boxtimes d})^{\mathfrak{S}_d}$ of \mathfrak{S}_d -invariants in $\mathfrak{S}_d \curvearrowright \mathcal{C}^{\boxtimes d}$.

We denote the result above by $\mathcal{W}_d(\mathcal{C}) := (\mathcal{C}^{\boxtimes d})^{\mathfrak{S}_d}$. In this section we see how this process works. Actually the category $\mathcal{S}_t(\mathcal{C})$ for $t \in k$, which is our main product in this paper, interpolates the family of categories $\mathcal{W}_d(\mathcal{C})$ for $d \in \mathbb{N}$.

3.1. Tensor product of categories

First we study the tensor product of k -linear categories. Recall that if A and B are both k -algebras then so is $A \otimes B$ naturally. We see that tensor product of algebras in representation theory corresponds to that of categories in category theory.

Definition 3.1. Let \mathcal{C}, \mathcal{D} be k -linear categories. Their tensor product $\mathcal{C} \boxtimes \mathcal{D}$ is the k -linear category defined as follows:

Object a symbol $U \boxtimes V$ for a pair of objects $U \in \mathcal{C}$ and $V \in \mathcal{D}$.

Morphism $Hom_{\mathcal{C} \boxtimes \mathcal{D}}(U \boxtimes V, U' \boxtimes V') := Hom_{\mathcal{C}}(U, U') \otimes Hom_{\mathcal{D}}(V, V')$ and composition of morphisms is diagonal. We denote a morphism by $f \boxtimes g$ instead of $f \otimes g$ for $f \in Hom_{\mathcal{C}}(U, U')$ and $g \in Hom_{\mathcal{D}}(V, V')$.

This operation naturally defines a 2-bifunctor $\boxtimes: \mathbf{Cat}_k \times \mathbf{Cat}_k \rightarrow \mathbf{Cat}_k$. For k -linear functors $F: \mathcal{C} \rightarrow \mathcal{C}'$ and $G: \mathcal{D} \rightarrow \mathcal{D}'$, the k -linear functor $F \boxtimes G: \mathcal{C} \boxtimes \mathcal{D} \rightarrow \mathcal{C}' \boxtimes \mathcal{D}'$ acts on objects and morphisms diagonally. For k -linear transformations $\eta: F \rightarrow F'$ and $\kappa: G \rightarrow G'$, the k -linear transformation $\eta \boxtimes \kappa: F \boxtimes G \rightarrow F' \boxtimes G'$ is defined by

$$(\eta \boxtimes \kappa)(U \boxtimes V) := \eta(U) \boxtimes \kappa(V): F(U) \boxtimes G(V) \rightarrow F'(U) \boxtimes G'(V)$$

at each $U \in \mathcal{C}$ and $V \in \mathcal{D}$.

The product \boxtimes is associative and commutative up to equivalence, so we can write $\mathcal{C}_1 \boxtimes \dots \boxtimes \mathcal{C}_d$ without any confusions. If all terms are equal to \mathcal{C} , we denote it by $\mathcal{C}^{\boxtimes d} := \mathcal{C} \boxtimes \dots \boxtimes \mathcal{C}$. It is convenient to set $\mathcal{C}^{\boxtimes 0} := Triv_k$, the unit with respect to \boxtimes . The operation $\mathcal{C} \mapsto \mathcal{C}^{\boxtimes d}$ also defines a 2-functor $\mathbf{Cat}_k \rightarrow \mathbf{Cat}_k$.

One of the purpose of considering the tensor product of categories is to create a universal object related to k -bilinear functors: the category of k -bilinear functors $\mathcal{C} \times \mathcal{D} \rightarrow \mathcal{E}$ is equivalent to the category of k -linear functors $\mathcal{C} \boxtimes \mathcal{D} \rightarrow \mathcal{E}$. It is equivalent to say that the natural functor

$$Hom_k(\mathcal{C} \boxtimes \mathcal{D}, \mathcal{E}) \xrightarrow{\sim} Hom_k(\mathcal{C}, Hom_k(\mathcal{D}, \mathcal{E}))$$

is a category equivalence (recall that the category $Hom_k(\mathcal{D}, \mathcal{E})$ is again k -linear). For pseudo-abelian categories, it is natural to define the tensor product by $\mathcal{C} \overline{\boxtimes} \mathcal{D} := \mathcal{P}s(\mathcal{C} \boxtimes \mathcal{D})$. It satisfies the same universality as above in the 2-category \mathbf{PsCat}_k . The unit for $\overline{\boxtimes}$ is $\mathcal{P}s(Triv_k) \simeq \mathcal{R}ep(k)$.

Now let us pay attention to its representation-theoretic properties listed in the next proposition. Recall that for a k -algebra A , $Mod(A)$ is the category of all A -modules and $\mathcal{R}ep(A)$ is the category of A -modules which are finitely generated and projective over k .

Proposition 3.2. Let A and B be k -algebras.

- (1) There is a canonical functor $Mod(A) \overline{\boxtimes} Mod(B) \rightarrow Mod(A \otimes B)$ which sends an object $U \boxtimes V$ to the $(A \otimes B)$ -module $U \otimes V$ on which $A \otimes B$ acts diagonally.
- (2) If $\mathcal{R}ep(A)$ is hom-finite and projective, the restriction $\mathcal{R}ep(A) \overline{\boxtimes} \mathcal{R}ep(B) \rightarrow \mathcal{R}ep(A \otimes B)$ of this functor is fully faithful.
- (3) Suppose that k is a field. If A and B are separable k -algebras, the restricted functor above gives a category equivalence.

Proof. (1) Obvious.

(2) Let $U, U' \in \mathcal{R}ep(A)$ and $V, V' \in \mathcal{R}ep(B)$. By the assumptions V' and $Hom_A(U, U')$ are finitely generated and projective over k , thus we get

$$\begin{aligned} Hom_{A \otimes B}(U \otimes V, U' \otimes V') &\simeq Hom_B(V, Hom_A(U, U' \otimes V')) \\ &\simeq Hom_B(V, Hom_A(U, U') \otimes V') \\ &\simeq Hom_A(U, U') \otimes Hom_B(V, V'). \end{aligned}$$

(3) Since the functor is fully faithful by (2), it suffices to prove that the functor is essentially surjective. For a separable k -algebra C , let $I(C)$ be the set of all finite dimensional irreducible C -modules up to isomorphism. Since $A \otimes B$ is also separable, it suffices to show that the image of the functor contains $I(A \otimes B)$. If k is algebraically closed the statement follows from the well known fact

$$I(A \otimes B) = \{U \otimes V \mid U \in I(A), V \in I(B)\}.$$

For a general field k , let \bar{k} be the algebraic closure of k and let us denote a field extension $\bullet \otimes \bar{k}$ by $\bar{\bullet}$. We use the next fact to prove the statement. The proof is easy and we omit it.

Lemma 3.3. *Let C be a separable k -algebra. Then for each $L \in I(\bar{C})$ there exists unique $L' \in I(C)$ such that L appears in the irreducible components of \bar{L}' .*

By the lemma for A and B we get that each object in $I(\overline{A \otimes B})$ is a direct summand of $\overline{U \otimes V}$ for some $U \in I(A)$ and $V \in I(B)$. Using the lemma for $A \otimes B$ again, we conclude the statement. \square

We interpret these results as follows. Using the data of representation categories of A and B we can imitate that of $A \otimes B$ to some extent, even if we do not know about the base algebras A and B themselves. So we regard $\mathcal{R}ep(A) \boxtimes \mathcal{R}ep(B)$ as a replica of $\mathcal{R}ep(A \otimes B)$ for any A and B .

3.2. Group action on category

Suppose that a group G acts on a k -algebra A by k -linear automorphisms of algebra. For the consistency of notations we denote the action of $g \in G$ by conjugation $a \in A \mapsto gag^{-1} \in A$. Then for each $g \in G$ and an A -module U , we can define the twisted A -module

$$g \cdot U := \{\text{symbol } g \cdot u \mid u \in U\}$$

whose A -action is defined by $a(g \cdot u) := g \cdot (g^{-1}ag)u$. This defines a G -action on the k -linear category $\mathcal{M}od(A)$ described below.

Definition 3.4. Let G be a group and \mathcal{C} a k -linear category. An *action* $\mathcal{M}: G \curvearrowright \mathcal{C}$ is a collection of k -linear endofunctors $\mathcal{M}_g: U \mapsto g \cdot U$ on \mathcal{C} for all $g \in G$ equipped with functorial isomorphisms $\mu_{\mathcal{M}}^{g,h}(U): g \cdot (h \cdot U) \simeq gh \cdot U$ for each $g, h \in G$ and $\iota_{\mathcal{M}}(U): U \simeq 1 \cdot U$ for the unit element $1 \in G$ such that the diagrams below commute:

$$\begin{array}{ccc} g \cdot (h \cdot (k \cdot U)) & \xrightarrow{\mu_{\mathcal{M}}^{h,k}(U)} & g \cdot (hk \cdot U) \\ \mu_{\mathcal{M}}^{g,h}(k \cdot U) \downarrow & & \downarrow \mu_{\mathcal{M}}^{g,hk}(U) \\ gh \cdot (k \cdot U) & \xrightarrow{\mu_{\mathcal{M}}^{gh,k}(U)} & ghk \cdot U, \end{array} \quad \begin{array}{ccc} g \cdot U & \xrightarrow{\mu_{\mathcal{M}}^{g,1}(U)} & g \cdot (1 \cdot U) \\ \iota_{\mathcal{M}}(g \cdot U) \downarrow & \searrow & \downarrow \mu_{\mathcal{M}}^{g,1}(U) \\ 1 \cdot (g \cdot U) & \xrightarrow{\mu_{\mathcal{M}}^{1,g}(U)} & g \cdot U. \end{array}$$

For example, on any k -linear category \mathcal{C} we can define the *trivial action* of G by $\mathcal{M}_g := \text{Id}_{\mathcal{C}}$. If groups G and H act on k -linear categories \mathcal{C} and \mathcal{D} respectively, $G^{op} \times H$ and $G \times H$ naturally act on $\mathcal{H}om_k(\mathcal{C}, \mathcal{D})$ and $\mathcal{C} \boxtimes \mathcal{D}$ respectively.

Definition 3.5. Let G be a group and \mathcal{C} be a k -linear category on which G acts.

- (1) A G -invariant object $U \in \mathcal{C}$ is an object equipped with a collection of isomorphisms $\kappa_U^g : g \cdot U \simeq U$ for all $g \in G$ such that the diagrams below commute:

$$\begin{array}{ccc}
 g \cdot (h \cdot U) & \xrightarrow{g \cdot \kappa_U^h} & g \cdot U & \xrightarrow{\kappa_U^g} & U \\
 \mu_{\mathcal{M}}^{g,h}(U) \downarrow & & & & \parallel \\
 gh \cdot U & \xrightarrow{\kappa_U^{gh}} & U & & \\
 \end{array}
 \qquad
 \begin{array}{ccc}
 U & & \\
 \iota_{\mathcal{M}}(U) \downarrow & \searrow & \\
 1 \cdot U & \xrightarrow{\kappa_U^1} & U.
 \end{array}$$

- (2) A G -invariant morphism $\varphi : U \rightarrow V$ between G -invariant objects is a morphism such that the diagram below commutes:

$$\begin{array}{ccc}
 U & \xrightarrow{\varphi} & V \\
 \kappa_V^g \downarrow & & \downarrow \kappa_U^g \\
 g \cdot U & \xrightarrow{g \cdot \varphi} & g \cdot V.
 \end{array}$$

- (3) We denote by \mathcal{C}^G the k -linear category consisting of G -invariant objects and morphisms.

Remark 3.6. Although we do not use it explicitly in this paper, one can easily define the 2-category $G\text{-Cat}_k$ consisting of k -linear categories with G -actions along with G -equivalent functors and G -equivalent transformations. Taking invariants $\mathcal{C} \mapsto \mathcal{C}^G$ is a 2-functor $G\text{-Cat}_k \rightarrow \text{Cat}_k$ and this is the right adjoint of the 2-functor which attaches the trivial G -action to a given category.

Now let G be a group acts on a k -algebra A . Recall that the semidirect product $A \rtimes G$ of A and G is a k -algebra which is isomorphic to $A \otimes k[G]$ as k -module and its product is defined by $(a \otimes g)(b \otimes h) := a(gbg^{-1}) \otimes gh$ for $a, b \in A$ and $g, h \in G$. We see here that making the semidirect product of an algebra is exactly taking the invariants of a category.

Proposition 3.7. For G and A as above, there are equivalences $\text{Mod}(A)^G \xrightarrow{\sim} \text{Mod}(A \rtimes G)$ and $\text{Rep}(A)^G \xrightarrow{\sim} \text{Rep}(A \rtimes G)$.

Proof. For each G -invariant A -module U , using isomorphisms $\kappa_U^g : g \cdot U \simeq U$, we can define a $A \rtimes G$ action on it by $(a \otimes g)u := a\kappa_U^g(g \cdot u)$. On the other hand, for each $(A \rtimes G)$ -module U , there are natural A -module isomorphisms $g \cdot U \simeq U; g \cdot u \mapsto (1 \otimes g)u$. It is easy to check that they are well-defined and two functors above are inverse to each other. \square

Now suppose that a group G acts on a k -linear category \mathcal{C} . To create G -invariant objects in \mathcal{C} , we can use the technique of *restriction* and *induction* as we do for ordinary representations of groups.

Definition 3.8. Let $H \subset G$ be a group and its subgroup and \mathcal{C} a k -linear category on which G acts. We denote by $\text{Res}_H^G : \mathcal{C}^G \rightarrow \mathcal{C}^H$ the obvious forgetful functor and call it the *restriction functor*. If it has the left adjoint, we denote it by $\text{Ind}_H^G : \mathcal{C}^H \rightarrow \mathcal{C}^G$ and call it the *induction functor*.

Proposition 3.9. Let G, H and \mathcal{C} be as above. If $\#(G/H) < \infty$ and \mathcal{C} is additive, then the induction functor exists. In this case, Ind_H^G is also the right adjoint of Res_H^G .

Proof. First let us choose representatives of the left coset G/H , namely $G/H = \{g_1, \dots, g_l\}$. For $U \in \mathcal{C}^H$ we define an object $Ind_H^G(U) \in \mathcal{C}$ by

$$Ind_H^G(U) := \bigoplus_{i=1, \dots, l} g_i \cdot U.$$

Take any $h \in G$. For each $i \in \{1, \dots, l\}$, there exist unique $h^{(i)} \in H$ and $i' \in \{1, \dots, l\}$ such that $hg_i = g_{i'}h^{(i)}$. Thus there is an isomorphism

$$h \cdot Ind_H^G(U) \simeq \bigoplus_{i=1, \dots, l} h \cdot (g_i \cdot U) \simeq \bigoplus_{i=1, \dots, l} g_{i'} \cdot (h^{(i)} \cdot U) \simeq \bigoplus_{i=1, \dots, l} g_{i'} \cdot U \simeq Ind_H^G(U).$$

These isomorphisms define a structure of G -invariant object on $Ind_H^G(U)$. It is easy to check that this construction is functorial and gives the left adjoint of Res_H^G . The last statement follows from considering the opposite category. \square

Corollary 3.10. *Let \mathcal{C} be a k -linear category on which a group G acts. Suppose that $\#G < \infty$ and $\#G \in k$ is invertible. Then all objects of the form $Ind_{\{1\}}^G(U)$ for $U \in \mathcal{C}$ generate a pseudo-abelian category $\mathcal{P}S(\mathcal{C})^G$.*

Proof. Take an arbitrary $U \in \mathcal{P}S(\mathcal{C})^G$. There are morphisms in $\mathcal{P}S(\mathcal{C})^G$

$$U \xrightarrow{i} Ind_{\{1\}}^G Res_{\{1\}}^G(U) \xrightarrow{p} U$$

induced by $g \cdot U \simeq U$ for all $g \in G$. Since $p \circ i = (\#G)id_U$, the idempotent $(\#G)^{-1}i \circ p$ has its image in $Ind_{\{1\}}^G Res_{\{1\}}^G(U)$ isomorphic to U . \square

3.3. Wreath product of algebra

Now we consider the main topic of this section, representation categories of wreath products.

Notation 3.11. Let X be a finite set. We denote by $P(X)$ the set of all equivalence relations on X , and for $p \in P(X)$ we write $x \sim_p y$ if x and y are equivalent with respect to p . There is a natural bijection from the set of partitions of X to $P(X)$:

$$X = X_1 \sqcup \dots \sqcup X_l \xleftrightarrow{1:1} x \sim_p y \iff x, y \text{ are in the same } X_i.$$

So we call $p \in P(X)$ a *partition* and represent by $p = \{X_1, \dots, X_l\}$ that each X_i is an equivalence class of X by p . We denote by $\#p$ the number of its equivalence classes and call it the *length* of p .

$P(X)$ is partially ordered with respect to strength of relations. For two partitions $p, q \in P(X)$ we write $p \leq q$ if $x \sim_q y$ implies $x \sim_p y$. We also say that the partition q is a *refinement* of p when $p \leq q$. The *common refinement* $p \wedge q \in P(X)$ of two partitions $p, q \in P(X)$ is defined by

$$x \sim_{p \wedge q} y \iff x \sim_p y \text{ and } x \sim_q y.$$

Beware that it is the *least upper bound* of p and q , not the *greatest lower bound* in the language of partially ordered set.

We denote by \mathfrak{S}_X the group of all bijections from X to X itself and call the *symmetric group* on X . For $p = \{X_1, \dots, X_l\} \in P(X)$, we define the subgroup $\mathfrak{S}_p \subset \mathfrak{S}_X$ by

$$\begin{aligned} \mathfrak{S}_p &:= \{g \in \mathfrak{S}_X \mid x \sim_p g(x) \text{ for all } x \in X\} \\ &\simeq \mathfrak{S}_{X_1} \times \cdots \times \mathfrak{S}_{X_l}. \end{aligned}$$

It is called a *Young subgroup* of \mathfrak{S}_X . \mathfrak{S}_X also acts on $P(X)$ as follows: for $g \in \mathfrak{S}_X$ and $p \in P(X)$, $g(p) \in P(X)$ is a partition such that

$$x \sim_{g(p)} y \iff g^{-1}(x) \sim_p g^{-1}(y).$$

If $d \in \mathbb{N}$ and $X = \{1, \dots, d\}$, we simply denote $P(X)$ and \mathfrak{S}_X by $P(d)$ and \mathfrak{S}_d respectively.

Definition 3.12. For a k -algebra A and $d \in \mathbb{N}$, the *wreath product* $A \wr \mathfrak{S}_d$ of A by \mathfrak{S}_d is the semidirect product $A^{\otimes d} \rtimes \mathfrak{S}_d$ where the symmetric group \mathfrak{S}_d acts on the d -fold tensor product $A^{\otimes d}$ by permutation of terms. More explicitly, $A \wr \mathfrak{S}_d$ is the k -algebra which is isomorphic to $A^{\otimes d} \otimes k[\mathfrak{S}_d]$ as k -module and its product is defined by

$$(a_1 \otimes \cdots \otimes a_d \otimes g)(b_1 \otimes \cdots \otimes b_d \otimes h) = (a_1 b_{g^{-1}(1)}) \otimes \cdots \otimes (a_d b_{g^{-1}(d)}) \otimes gh$$

for $a_1, \dots, a_d, b_1, \dots, b_d \in A$ and $g, h \in \mathfrak{S}_d$. For $p \in P(d)$, let $A \wr \mathfrak{S}_p := A^{\otimes d} \rtimes \mathfrak{S}_p$. Obviously it is a k -subalgebra of $A \wr \mathfrak{S}_d$.

Let us create representation categories of wreath products of algebras in the language of categories. We already know what should it be by the preceding arguments.

Definition 3.13. Let $d \in \mathbb{N}$ and \mathcal{C} be a k -linear category. We denote by $\mathcal{W}_d(\mathcal{C}) := (\mathcal{C}^{\boxtimes d})^{\mathfrak{S}_d}$ the category of \mathfrak{S}_d -invariants in the d -fold tensor product category $\mathcal{C}^{\boxtimes d}$ where the symmetric group \mathfrak{S}_d acts on it by permutation of terms. This induces a 2-functor $\mathcal{W}_d: \mathbf{Cat}_k \rightarrow \mathbf{PsCat}_k$.

Note that the \mathfrak{S}_d -action on $\text{Mod}(A^{\otimes d})$ induced by $\mathfrak{S}_d \curvearrowright A^{\otimes d}$ coincides with that we used in the definition above. Combining Propositions 3.2 and 3.7, we obtain the next results.

Proposition 3.14. *Let A be a k -algebra.*

- (1) *There is a canonical functor $\mathcal{W}_d(\text{Mod}(A)) \rightarrow \text{Mod}(A \wr \mathfrak{S}_d)$.*
- (2) *If $\text{Rep}(A)$ is hom-finite and projective, then the restriction $\mathcal{W}_d(\text{Rep}(A)) \rightarrow \text{Rep}(A \wr \mathfrak{S}_d)$ is fully faithful.*
- (3) *Suppose that k is a field. If A is a separable k -algebra, the restricted functor above gives a category equivalence.*

It is not hard to check that when \mathcal{C} is a k -tensor category our category $\mathcal{W}_d(\mathcal{C})$ also has a canonical structure of k -tensor category induced from that of \mathcal{C} . We have an enriched 2-functor $\mathcal{W}_d: \boxtimes\text{-Cat}_k \rightarrow \boxtimes\text{-PsCat}_k$ where $\boxtimes\text{-Cat}_k$ is the 2-category of k -tensor categories, functors and transformations, and $\boxtimes\text{-PsCat}_k$ is its full sub-2-category consisting of pseudo-abelian ones. On the other hand, if A is a k -bialgebra then the coproduct Δ_A and the counit ϵ_A of A will be lifted to those of $A \wr \mathfrak{S}_d$: for $a_1, \dots, a_d \in A$ and $g \in \mathfrak{S}_d$,

$$\begin{aligned} \Delta_{A_d}(a_1 \otimes \cdots \otimes a_d \otimes g) &= \sum (a_1^{(1)} \otimes \cdots \otimes a_d^{(1)} \otimes g) \otimes (a_1^{(2)} \otimes \cdots \otimes a_d^{(2)} \otimes g), \\ \epsilon_{A_d}(a_1 \otimes \cdots \otimes a_d \otimes g) &= \epsilon_A(a_1) \cdots \epsilon_A(a_d) \end{aligned}$$

so $A \wr \mathfrak{S}_d$ is also a k -bialgebra. Here we use the Sweedler notation $\Delta_A(a) = \sum a^{(1)} \otimes a^{(2)}$ to write coproducts. These structures are of course compatible and $\mathcal{W}_d(\text{Mod}(A)) \rightarrow \text{Mod}(A \wr \mathfrak{S}_d)$ induces a k -tensor functor. The same holds for k -braided tensor categories.

3.4. Induced objects from Young subgroups

For an object $U \in \mathcal{C}$, its d -fold tensor product $U^{\boxtimes d} \in \mathcal{C}^{\boxtimes d}$ is clearly \mathfrak{S}_d -invariant. More generally, let $p \in P(d)$ and take $U_1, \dots, U_d \in \mathcal{C}$ such that $U_i = U_j$ whenever $i \sim_p j$. Then the object $U_1 \boxtimes \dots \boxtimes U_d$ is \mathfrak{S}_p -invariant and we can induce this object to the \mathfrak{S}_d -invariant object

$$Ind_p(U_1 \boxtimes \dots \boxtimes U_d) := Ind_{\mathfrak{S}_p}^{\mathfrak{S}_d}(U_1 \boxtimes \dots \boxtimes U_d) \in \mathcal{W}_d(\mathcal{C}).$$

In this subsection we study the pseudo-abelian full subcategory $\mathcal{W}'_d(\mathcal{C})$ of $\mathcal{W}_d(\mathcal{C})$ generated by objects of this form. That is, an object in $\mathcal{W}'_d(\mathcal{C})$ is a direct summand of a direct sum of objects $Ind_p(U_1 \boxtimes \dots \boxtimes U_d)$. Note that if $\#\mathfrak{S}_d = d!$ is invertible in k , $\mathcal{W}'_d(\mathcal{C})$ coincides with the whole category $\mathcal{W}_d(\mathcal{C})$ by Corollary 3.10.

By its definition in the proof of Proposition 3.9,

$$Ind_p(U_1 \boxtimes \dots \boxtimes U_d) \simeq \bigoplus_{g \in \mathfrak{S}_d / \mathfrak{S}_p} U_{g^{-1}(1)} \boxtimes \dots \boxtimes U_{g^{-1}(d)}$$

as object in $\mathcal{C}^{\boxtimes d}$, so

$$\begin{aligned} Hom_{\mathcal{C}^{\boxtimes d}}(Ind_p(U_1 \boxtimes \dots \boxtimes U_d), Ind_q(V_1 \boxtimes \dots \boxtimes V_d)) \\ \simeq \bigoplus_{\substack{g \in \mathfrak{S}_d / \mathfrak{S}_p \\ h \in \mathfrak{S}_d / \mathfrak{S}_q}} Hom_{\mathcal{C}}(U_{g^{-1}(1)}, V_{h^{-1}(1)}) \otimes \dots \otimes Hom_{\mathcal{C}}(U_{g^{-1}(d)}, V_{h^{-1}(d)}). \end{aligned}$$

The symmetric group \mathfrak{S}_d acts on the space of $\mathcal{C}^{\boxtimes d}$ -morphisms above by permutation and $\mathcal{W}_d(\mathcal{C})$ -morphisms are exactly the fixed points of this action. To describe them more precisely, we first study the diagonal action $\mathfrak{S}_d \curvearrowright \mathfrak{S}_d / \mathfrak{S}_p \times \mathfrak{S}_d / \mathfrak{S}_q$. It is clear that the map

$$\begin{aligned} \mathfrak{S}_d / \mathfrak{S}_p \times \mathfrak{S}_d / \mathfrak{S}_q &\rightarrow \mathfrak{S}_p \setminus \mathfrak{S}_d / \mathfrak{S}_q \\ (g, h) &\mapsto g^{-1}h \end{aligned}$$

induces a bijection $\mathfrak{S}_d \setminus (\mathfrak{S}_d / \mathfrak{S}_p \times \mathfrak{S}_d / \mathfrak{S}_q) \xrightarrow{1:1} \mathfrak{S}_p \setminus \mathfrak{S}_d / \mathfrak{S}_q$, and the stabilizer subgroup of each $(g, h) \in \mathfrak{S}_d / \mathfrak{S}_p \times \mathfrak{S}_d / \mathfrak{S}_q$ is

$$g\mathfrak{S}_p g^{-1} \cap h\mathfrak{S}_q h^{-1} = \mathfrak{S}_{g(p)} \cap \mathfrak{S}_{h(q)} = \mathfrak{S}_{g(p) \wedge h(q)}.$$

Thus the orbit decomposition gives a bijection

$$\begin{aligned} \bigsqcup_{k \in \mathfrak{S}_p \setminus \mathfrak{S}_d / \mathfrak{S}_q} \mathfrak{S}_d / \mathfrak{S}_{p \wedge k(q)} &\xrightarrow{1:1} \mathfrak{S}_d / \mathfrak{S}_p \times \mathfrak{S}_d / \mathfrak{S}_q \\ (k; g) &\longmapsto (g, gk). \end{aligned}$$

Here the notation $k \in \mathfrak{S}_p \setminus \mathfrak{S}_d / \mathfrak{S}_q$ means that k runs over the representatives of the \mathfrak{S}_p -orbits of $\mathfrak{S}_d / \mathfrak{S}_q$. If we choose another representative $xk \in \mathfrak{S}_d / \mathfrak{S}_q$ for $x \in \mathfrak{S}_p$, there are canonical isomorphisms

$$\begin{aligned} \mathfrak{S}_{p \wedge k(q)} &\xrightarrow{\sim} \mathfrak{S}_{p \wedge xk(q)} & \mathfrak{S}_d / \mathfrak{S}_{p \wedge k(q)} &\xrightarrow{\sim} \mathfrak{S}_d / \mathfrak{S}_{p \wedge xk(q)} \\ y &\mapsto xyx^{-1}, & g &\mapsto gx^{-1}, \end{aligned}$$

so the bijection above is well-defined. This gives us an isomorphism

$$\begin{aligned} & Hom_{\mathcal{W}_d(\mathcal{C})}(Ind_p(U_1 \boxtimes \cdots \boxtimes U_d), Ind_q(V_1 \boxtimes \cdots \boxtimes V_d)) \\ & \simeq \left(\bigoplus_{\substack{g \in \mathfrak{S}_d / \mathfrak{S}_p \\ h \in \mathfrak{S}_d / \mathfrak{S}_q}} Hom_{\mathcal{C}}(U_{g^{-1}(1)}, V_{h^{-1}(1)}) \otimes \cdots \otimes Hom_{\mathcal{C}}(U_{g^{-1}(d)}, V_{h^{-1}(d)}) \right)^{\mathfrak{S}_d} \\ & \simeq \bigoplus_{k \in \mathfrak{S}_p \backslash \mathfrak{S}_d / \mathfrak{S}_q} \left(\bigoplus_{g \in \mathfrak{S}_d / \mathfrak{S}_{p \wedge k(q)}} Hom_{\mathcal{C}}(U_{g^{-1}(1)}, V_{(gk)^{-1}(1)}) \right. \\ & \quad \left. \otimes \cdots \otimes Hom_{\mathcal{C}}(U_{g^{-1}(d)}, V_{(gk)^{-1}(d)}) \right)^{\mathfrak{S}_d} \\ & \simeq \bigoplus_{k \in \mathfrak{S}_p \backslash \mathfrak{S}_d / \mathfrak{S}_q} (Hom_{\mathcal{C}}(U_1, V_{k^{-1}(1)}) \otimes \cdots \otimes Hom_{\mathcal{C}}(U_d, V_{k^{-1}(d)}))^{\mathfrak{S}_{p \wedge k(q)}}. \end{aligned}$$

Here, for each direct summand

$$(Hom_{\mathcal{C}}(U_1, V_{k^{-1}(1)}) \otimes \cdots \otimes Hom_{\mathcal{C}}(U_d, V_{k^{-1}(d)}))^{\mathfrak{S}_{p \wedge k(q)}}$$

in the right-hand side, its embedding is induced from

$$\varphi_1 \otimes \cdots \otimes \varphi_d \mapsto \sum_{g \in \mathfrak{S}_d / \mathfrak{S}_{p \wedge k(q)}} \varphi_{g^{-1}(1)} \boxtimes \cdots \boxtimes \varphi_{g^{-1}(d)}.$$

If \mathcal{C} is a k -tensor category, we can calculate tensor product of objects in the same manner. In the k -tensor category $\mathcal{C}^{\boxtimes d}$,

$$\begin{aligned} & Ind_p(U_1 \boxtimes \cdots \boxtimes U_d) \otimes Ind_q(V_1 \boxtimes \cdots \boxtimes V_d) \\ & \simeq \bigoplus_{\substack{g \in \mathfrak{S}_d / \mathfrak{S}_p \\ h \in \mathfrak{S}_d / \mathfrak{S}_q}} (U_{g^{-1}(1)} \boxtimes \cdots \boxtimes U_{g^{-1}(d)}) \otimes (V_{h^{-1}(1)} \boxtimes \cdots \boxtimes V_{h^{-1}(d)}) \\ & \simeq \bigoplus_{\substack{g \in \mathfrak{S}_d / \mathfrak{S}_p \\ h \in \mathfrak{S}_d / \mathfrak{S}_q}} (U_{g^{-1}(1)} \otimes V_{h^{-1}(1)}) \boxtimes \cdots \boxtimes (U_{g^{-1}(d)} \otimes V_{h^{-1}(d)}) \\ & \simeq \bigoplus_{k \in \mathfrak{S}_p \backslash \mathfrak{S}_d / \mathfrak{S}_q} \bigoplus_{g \in \mathfrak{S}_{p \wedge k(q)}} (U_{g^{-1}(1)} \otimes V_{(gk)^{-1}(1)}) \boxtimes \cdots \boxtimes (U_{g^{-1}(d)} \otimes V_{(gk)^{-1}(d)}) \\ & \simeq \bigoplus_{k \in \mathfrak{S}_p \backslash \mathfrak{S}_d / \mathfrak{S}_q} Ind_{p \wedge k(q)}((U_1 \otimes V_{k^{-1}(1)}) \boxtimes \cdots \boxtimes (U_d \otimes V_{k^{-1}(d)})). \end{aligned}$$

This isomorphism is clearly \mathfrak{S}_d -invariant. Moreover if \mathcal{C} has a braiding, the induced braiding at these objects are the direct sum of the morphisms

$$\begin{aligned} & Ind_{p \wedge k(q)}((U_1 \otimes V_{k^{-1}(1)}) \boxtimes \cdots \boxtimes (U_d \otimes V_{k^{-1}(d)})) \\ & \xrightarrow{\sim} Ind_{q \wedge k^{-1}(p)}((V_1 \otimes U_{k(1)}) \boxtimes \cdots \boxtimes (V_d \otimes U_{k(d)})). \end{aligned}$$

Thus the full subcategory $\mathcal{W}'_d(\mathcal{C})$ is closed under the tensor product and the braiding of $\mathcal{W}_d(\mathcal{C})$.

3.5. Restriction and induction

Let $d_1, d_2 \in \mathbb{N}$ and put $d := d_1 + d_2$. We write $i' := d_1 + i$ for $i = 1, \dots, d_2$. There is a natural embedding of groups $\mathfrak{S}_{d_1} \times \mathfrak{S}_{d_2} \hookrightarrow \mathfrak{S}_d$ where \mathfrak{S}_{d_1} and \mathfrak{S}_{d_2} acts on $\{1, \dots, d_1\}$ and

$\{1', \dots, d'_2\}$ respectively. Since there is a fully faithful embedding of categories

$$\mathcal{C}^G \boxtimes \mathcal{D}^H \rightarrow (\mathcal{C} \boxtimes \mathcal{D})^{G \times H}$$

when groups G and H acts on \mathcal{C} and \mathcal{D} respectively, we have the induction functor

$$Ind_{\mathfrak{S}_{d_1} \times \mathfrak{S}_{d_2}}^{\mathfrak{S}_d} : \mathcal{W}_{d_1}(\mathcal{C}) \boxtimes \mathcal{W}_{d_2}(\mathcal{C}) \rightarrow \mathcal{W}_d(\mathcal{C}).$$

To keep notations simple, we also use the binary operator $*$ to denote this induction functor:

$$U_1 * U_2 := Ind_{\mathfrak{S}_{d_1} \times \mathfrak{S}_{d_2}}^{\mathfrak{S}_d} (U_1 \boxtimes U_2).$$

This operator is associative and commutative up to canonical isomorphisms. The direct sum category $\mathcal{W}_\bullet(\mathcal{C}) := \bigoplus_{d \in \mathbb{N}} \mathcal{W}_d(\mathcal{C})$ forms a graded k -symmetric tensor category with respect to the product $*$.

In the other direction, we have no natural restriction functors since the embedding of categories above is not invertible in general. However, for an object of the form $Ind_p(U_1 \boxtimes \dots \boxtimes U_d)$ we can calculate its restriction to $\mathfrak{S}_{d_1} \times \mathfrak{S}_{d_2}$. We omit the proof of the next lemma.

Lemma 3.15. For $U_1, \dots, U_d \in \mathcal{C}$, in the k -linear category $(\mathcal{C} \boxtimes \mathcal{C})^{\mathfrak{S}_{d_1} \times \mathfrak{S}_{d_2}}$

$$\begin{aligned} & Ind_p(U_1 \boxtimes \dots \boxtimes U_d) \\ & \simeq \bigoplus_{g \in \mathfrak{S}_{d_1} \times \mathfrak{S}_{d_2} \setminus \mathfrak{S}_d / \mathfrak{S}_p} Ind_q(U_{g^{-1}(1)} \boxtimes \dots \boxtimes U_{g^{-1}(d_1)}) \\ & \quad \boxtimes Ind_{q'}(U_{g^{-1}(1')} \boxtimes \dots \boxtimes U_{g^{-1}(d'_2)}). \end{aligned}$$

Here $q \in P(d_1)$ and $q' \in P(d_2)$ are the restriction of the equivalent relation $g(p) \in P(d)$ to each components. The notation $g \in \mathfrak{S}_{d_1} \times \mathfrak{S}_{d_2} \setminus \mathfrak{S}_d / \mathfrak{S}_p$ is same as the previous one.

Thus we can define the restriction functor on $\mathcal{W}'_d(\mathcal{C})$:

$$Res_{\mathfrak{S}_{d_1} \times \mathfrak{S}_{d_2}}^{\mathfrak{S}_d} : \mathcal{W}'_d(\mathcal{C}) \rightarrow \mathcal{W}'_{d_1}(\mathcal{C}) \boxtimes \mathcal{W}'_{d_2}(\mathcal{C}).$$

It is both the left and the right adjoint of the restricted induction functor on $\mathcal{W}'_d(\mathcal{C})$.

On the other hand, let $d_1, d_2 \in \mathbb{N}$ and put $d := d_1 d_2$. Let us write $i^{(j)} := (j - 1)d_1 + i$ for $i = 1, \dots, d_1$ and $j = 1, \dots, d_2$. The wreath product of the symmetric group $\mathfrak{S}_{d_1} \wr \mathfrak{S}_{d_2}$ can also be embedded into \mathfrak{S}_d naturally: the j -th component of $(\mathfrak{S}_{d_1})^{d_2}$ correspond to the permutations on $\{1^{(j)}, \dots, d_1^{(j)}\}$ and \mathfrak{S}_{d_2} shuffles the index j of $i^{(j)}$ for all $i = 1, \dots, d_1$ simultaneously. This gives us the induction functor and the restriction functor again:

$$\begin{aligned} & Ind_{\mathfrak{S}_{d_1} \wr \mathfrak{S}_{d_2}}^{\mathfrak{S}_d} : \mathcal{W}_{d_2}(\mathcal{W}_{d_1}(\mathcal{C})) \rightarrow \mathcal{W}_d(\mathcal{C}), \\ & Res_{\mathfrak{S}_{d_1} \wr \mathfrak{S}_{d_2}}^{\mathfrak{S}_d} : \mathcal{W}'_d(\mathcal{C}) \rightarrow \mathcal{W}'_{d_2}(\mathcal{W}'_{d_1}(\mathcal{C})). \end{aligned}$$

Their calculations are same for $\mathfrak{S}_{d_1} \times \mathfrak{S}_{d_2}$ but using $\mathfrak{S}_{d_1} \wr \mathfrak{S}_{d_2}$.

4. Wreath product in non-integral rank

In this section we introduce our main product in this paper, the category $\mathcal{S}_t(\mathcal{C})$. It interpolates $\mathcal{W}_d(\mathcal{C})$, the categories of representations of wreath products from $d \in \mathbb{N}$ to $t \in k$. The original idea of the arguments is due to Deligne [5] who first consider the representation theory of symmetric group of non-integral rank.

4.1. Definition of 2-functor \mathcal{S}_l

To apply the 2-functor \mathcal{S}_l , we need the fixed “unit object” in the target category. So we introduce the notion of “category with unit” as follows.

- Definition 4.1.** (1) A *k-linear category with unit* is a *k-linear category* \mathcal{C} equipped with a fixed object $\mathbb{1}_{\mathcal{C}} \in \mathcal{C}$ which satisfies $\text{End}_{\mathcal{C}}(\mathbb{1}_{\mathcal{C}}) \simeq k$.
 (2) A *k-linear functor with unit* from \mathcal{C} to \mathcal{D} is a *k-linear functor* $F: \mathcal{C} \rightarrow \mathcal{D}$ along with an isomorphism $\iota_F: \mathbb{1}_{\mathcal{D}} \xrightarrow{\sim} F(\mathbb{1}_{\mathcal{C}})$.
 (3) A *k-linear transformation with unit* from F to G is a *k-linear transformation* $\eta: F \rightarrow G$ which satisfies the same condition as *k-tensor transformations*, i.e. $\eta(\mathbb{1}_{\mathcal{C}}) = id_{\mathbb{1}_{\mathcal{D}}}$. See the diagram on the right in Definition 2.12(2).

We denote by $\mathbb{1}\text{-Cat}_k$ the 2-category consisting of *k-linear categories*, functors and transformations with unit. Obviously there are forgetful 2-functors $\otimes\text{-Cat}_k \rightarrow \mathbb{1}\text{-Cat}_k \rightarrow \text{Cat}_k$. The reader should check that we can apply all the 2-functors we have defined to categories with unit and create new categories with unit.

Now fix a *k-linear category* \mathcal{C} with unit and $d \in \mathbb{N}$.

Definition 4.2. Let I be a finite set and $U_I = (U_i)_{i \in I}$ be a family of objects in \mathcal{C} indexed by I . Set $m = \#I$ and write $I = \{i_1, \dots, i_m\}$. Let us define $[U_I]_d \in \mathcal{W}_d(\mathcal{C})$ by

$$[U_I]_d := \begin{cases} U_{i_1} * \dots * U_{i_m} * \mathbb{1}_{\mathcal{C}}^{\boxtimes(d-m)}, & \text{if } m \leq d, \\ 0, & \text{otherwise.} \end{cases}$$

This object is well-defined because it does not depend on the order of i_1, \dots, i_m . We also write $[U_I]_d$ as $[U_{i_1}, \dots, U_{i_m}]_d$.

Before studying these objects, we introduce some notations.

Definition 4.3. Let I_1, \dots, I_l be finite sets. A *recollement (gluing)* of I_1, \dots, I_l is a partition $r \in P(I_1 \sqcup \dots \sqcup I_l)$ such that for any $a = 1, \dots, l$ and $i, i' \in I_a$, $i \sim_r i'$ implies $i = i'$. In other words, r is a recollement if each $I_a \rightarrow (I_1 \sqcup \dots \sqcup I_l) / \sim_r$ is injective. Let us denote by $R(I_1, \dots, I_l)$ the set of recollements of I_1, \dots, I_l .

For $\{a_1, \dots, a_p\} \subset \{1, \dots, l\}$, let $\pi_{a_1, \dots, a_p}: R(I_1, \dots, I_l) \rightarrow R(I_{a_1}, \dots, I_{a_p})$ be the map which takes restriction of equivalence relation via $I_{a_1} \sqcup \dots \sqcup I_{a_p} \subset I_1 \sqcup \dots \sqcup I_l$.

Notation 4.4. For example, $R(I, J)$ is the set of partitions of the form

$$r = \{\{i, j\}, \dots, \{i'\}, \dots, \{j'\}, \dots\}$$

where $i, i', \dots \in I$ and $j, j', \dots \in J$. For convenience, we represent such r by

$$r = \{(i, j), \dots, (i', \emptyset), \dots, (\emptyset, j'), \dots\}$$

where \emptyset is another index different from any element of $I \sqcup J$ so that we can simply write recollement as $r = \{(i, j), \dots\}$. For more than two sets I_1, \dots, I_l , we use the same notation $r = \{(i_1, \dots, i_l), \dots\} \in R(I_1, \dots, I_l)$. For any family of objects U_I in \mathcal{C} , the symbol U_i denotes the unit element $\mathbb{1}_{\mathcal{C}}$ if $i = \emptyset$.

Definition 4.5. Let U_I, V_J be finite families of objects in \mathcal{C} . For $r \in R(I, J)$, define the k -module

$$H(U_I; V_J) := \bigoplus_{r \in R(I, J)} H_r(U_I; V_J)$$

where for each $r \in R(I, J)$,

$$H_r(U_I; V_J) := \bigotimes_{(i, j) \in r} \text{Hom}_{\mathcal{C}}(U_i, V_j).$$

This k -module is \mathbb{N} -graded by length of recollements. Let

$$H^d(U_I; V_J) := \bigoplus_{\substack{r \in R(I, J) \\ \#r=d}} H_r(U_I; V_J)$$

and write $H^{\leq d}(U_I; V_J) := \bigoplus_{e \leq d} H^e(U_I; V_J)$ and $H^{> d}(U_I; V_J) := \bigoplus_{e > d} H^e(U_I; V_J)$. Obviously $H^d(U_I; V_J) = 0$ unless $\#I, \#J \leq d \leq \#I + \#J$.

Let I, J be finite sets such that $\#I, \#J \leq d$. Write $I = \{i_1, \dots, i_m\}$, $J = \{j_1, \dots, j_n\}$ and let $p, q \in P(d)$ as

$$p = \{\{1\}, \dots, \{m\}, \{m + 1, \dots, d\}\}, \quad q = \{\{1\}, \dots, \{n\}, \{n + 1, \dots, d\}\}$$

respectively. For each $g \in \mathfrak{S}_d$, we can take a unique recollement $r \in R(I, J)$ which satisfies $i_k \sim_r j_l$ if and only if $g(k) = l$. The correspondence $g \mapsto r$ induces a bijection $\mathfrak{S}_p \setminus \mathfrak{S}_d / \mathfrak{S}_q \xrightarrow{1:1} \{r \in R(I, J) \mid \#r \leq d\}$. Thus the isomorphism in Section 3.4 gives

$$\text{Hom}_{\mathcal{W}_d(\mathcal{C})}([U_I]_d, [V_J]_d) \simeq H^{\leq d}(U_I; V_J).$$

This is also true when $\#I > d$ or $\#J > d$ because both sides are zero.

For $\Phi \in H^{\leq d}(U_I; V_J)$, let us denote by $[\Phi]_d: [U_I]_d \rightarrow [V_J]_d$ the map corresponding to Φ via the isomorphism above. We give an explicit description of it here.

Definition 4.6. Let I, J be finite sets. We say that a sequence $((i_1, j_1), \dots, (i_d, j_d))$ for $i_1, \dots, i_d \in I \sqcup \{\emptyset\}$, $j_1, \dots, j_d \in J \sqcup \{\emptyset\}$ is *adapted* to a recollement $r \in R(I, J)$ if the sequence obtained by removing all (\emptyset, \emptyset) 's from it is equal to a permutation of all the elements in the set $r = \{(i, j), \dots\}$.

Recall that $[U_I]_d$ is a direct sum of objects of the form $U_{i_1} \boxtimes \dots \boxtimes U_{i_d}$ ($i_1, \dots, i_d \in I \sqcup \{\emptyset\}$) in $\mathcal{C}^{\boxtimes d}$. Let $r \in R(I, J)$ and $\Phi \in H_r(U_I, V_J)$. Each matrix entry of $[\Phi]_d: [U_I]_d \rightarrow [V_J]_d$ at the cell

$$U_{i_1} \boxtimes \dots \boxtimes U_{i_d} \rightarrow V_{j_1} \boxtimes \dots \boxtimes V_{j_d}$$

for $i_1, \dots, i_d \in I \sqcup \{\emptyset\}$, $j_1, \dots, j_d \in J \sqcup \{\emptyset\}$ is equal to Φ (after reordering the tensor terms) if $((i_1, j_1), \dots, (i_d, j_d))$ is adapted to r and otherwise zero.

We extend the usage of this symbol $[\Phi]_d$ for $\Phi \in H^{> d}(U_I; V_J)$ so that $[\Phi]_d = 0$. Thus we have a k -linear map $[\bullet]_d: H(U_I; V_J) \rightarrow \text{Hom}_{\mathcal{W}_d(\mathcal{C})}([U_I]_d, [V_J]_d)$ which is surjective and whose kernel is $H^{> d}(U_I; V_J)$.

Example 4.7. Let us consider the case $d = 3$. Take objects $U, V \in \mathcal{C}$ then we have

$$\text{Hom}_{\mathcal{W}_3(\mathcal{C})}([U]_3, [V]_3) \simeq \text{Hom}_{\mathcal{C}}(U, V) \oplus (\text{Hom}_{\mathcal{C}}(U, \mathbb{1}_{\mathcal{C}}) \otimes \text{Hom}_{\mathcal{C}}(\mathbb{1}_{\mathcal{C}}, V)).$$

Let us confirm this directly as follows. In $\mathcal{C}^{\boxtimes 3}$,

$$\begin{aligned}
 [U]_3 &\simeq (U \boxtimes \mathbb{1}_{\mathcal{C}} \boxtimes \mathbb{1}_{\mathcal{C}}) \oplus (\mathbb{1}_{\mathcal{C}} \boxtimes U \boxtimes \mathbb{1}_{\mathcal{C}}) \oplus (\mathbb{1}_{\mathcal{C}} \boxtimes \mathbb{1}_{\mathcal{C}} \boxtimes U), \\
 [V]_3 &\simeq (V \boxtimes \mathbb{1}_{\mathcal{C}} \boxtimes \mathbb{1}_{\mathcal{C}}) \oplus (\mathbb{1}_{\mathcal{C}} \boxtimes V \boxtimes \mathbb{1}_{\mathcal{C}}) \oplus (\mathbb{1}_{\mathcal{C}} \boxtimes \mathbb{1}_{\mathcal{C}} \boxtimes V).
 \end{aligned}$$

For morphisms $\varphi: U \rightarrow V$, $\psi: U \rightarrow \mathbb{1}_{\mathcal{C}}$ and $\xi: \mathbb{1}_{\mathcal{C}} \rightarrow V$ in \mathcal{C} , the morphisms $[\varphi]_3: [U]_3 \rightarrow [V]_3$ and $[\psi \otimes \xi]_3: [U]_3 \rightarrow [V]_3$ in $\mathcal{C}^{\boxtimes 3}$ are represented by the matrices

$$\begin{aligned}
 [\varphi]_3 &:= \begin{pmatrix} \varphi \boxtimes 1 \boxtimes 1 & 0 & 0 \\ 0 & 1 \boxtimes \varphi \boxtimes 1 & 0 \\ 0 & 0 & 1 \boxtimes 1 \boxtimes \varphi \end{pmatrix}, \\
 [\psi \otimes \xi]_3 &:= \begin{pmatrix} 0 & \xi \boxtimes \psi \boxtimes 1 & \xi \boxtimes 1 \boxtimes \psi \\ \psi \boxtimes \xi \boxtimes 1 & 0 & 1 \boxtimes \xi \boxtimes \psi \\ \psi \boxtimes 1 \boxtimes \xi & 1 \boxtimes \psi \boxtimes \xi & 0 \end{pmatrix}
 \end{aligned}$$

respectively where 1 stands for $id_{\mathbb{1}_{\mathcal{C}}}: \mathbb{1}_{\mathcal{C}} \rightarrow \mathbb{1}_{\mathcal{C}}$. It is clear that the space of all \mathfrak{S}_3 -invariant morphisms in $\mathcal{C}^{\boxtimes 3}$ are spanned by them. It is true for all $d \geq 2$ but when $d = 0$ or 1 the matrices become smaller and some of the non-zero terms disappear.

What we have to do next is to compute the composition of these morphisms.

Definition 4.8. Let $r \in R(I, J)$, $s \in R(J, K)$ be two recollements. We define the set

$$R(s \circ r) := \{u \in R(I, J, K) \mid \pi_{1,2}(u) = r, \pi_{2,3}(u) = s\}.$$

For $u \in R(s \circ r)$, $\Phi \in H_r(U_I; V_J)$ and $\Psi \in H_s(V_J; W_K)$, we denote by $\Psi \circ_u \Phi \in H_{\pi_{1,3}(u)}(U_I; W_K)$ the element obtained by composing terms of $\Phi \otimes \Psi$ using compositions

$$Hom_{\mathcal{C}}(U_i, V_j) \otimes Hom_{\mathcal{C}}(V_j, W_k) \rightarrow Hom_{\mathcal{C}}(U_i, W_k)$$

for all $(i, j, k) \in u$. If both i and k are \emptyset , the composite of $\mathbb{1}_{\mathcal{C}} \rightarrow V_j \rightarrow \mathbb{1}_{\mathcal{C}}$ is regarded as a scalar in $k \simeq End_{\mathcal{C}}(\mathbb{1}_{\mathcal{C}})$.

Lemma 4.9. Let $\Phi \in H_r(U_I; V_J)$, $\Psi \in H_s(V_J; W_K)$ be as above. Then

$$[\Psi]_d \circ [\Phi]_d = \sum_{u \in R(s \circ r)} P_u(d) [\Psi \circ_u \Phi]_d$$

where P_u is the polynomial

$$P_u(T) := \prod_{\#\pi_{1,3}(u) \leq a < \#u} (T - a) = (T - \#\pi_{1,3}(u)) \cdots (T - \#u + 1).$$

Note that the degree $\#u - \#\pi_{1,3}(u)$ of P_u does not depend on the choice of $u \in R(s \circ r)$. This is equal to the number of ‘orphans’ $(\emptyset, j, \emptyset) \in u$ in J .

Proof. If $\#I > d$ or $\#K > d$, both sides above are zero and the equation clearly holds. Otherwise the composite is a sum of morphisms of the form $[\Psi \circ_u \Phi]_d$. Since $\pi_{1,3}: R(s \circ r) \rightarrow R(I, K)$ is injective, we can uniquely write

$$[\Psi]_d \circ [\Phi]_d = \sum_{\substack{u \in R(s \circ r) \\ \#\pi_{1,3}(u) \leq d}} a_u [\Psi \circ_u \Phi]_d$$

for some $a_u \in \mathbb{N}$ for each $u \in R(s \circ r)$. So take $u \in R(s \circ r)$ with $\#\pi_{1,3}(u) \leq d$ and fix a sequence $((i_1, k_1), \dots, (i_d, k_d))$ adapted to $\pi_{1,3}(u)$. Since the matrix entry of $[\Psi]_d \circ [\Phi]_d$ in $\mathbb{C}^{\boxtimes d}$ at the cell

$$U_{i_1} \boxtimes \dots \boxtimes U_{i_d} \rightarrow W_{k_1} \boxtimes \dots \boxtimes W_{k_d}$$

coincides with $a_u(\Psi \circ_u \Phi)$, a_u is equal to the number of sequences (j_1, \dots, j_d) such that both $((i_1, j_1), \dots, (i_d, j_d))$ and $((j_1, k_1), \dots, (j_d, k_d))$ are adapted to the recollements r and s respectively. For $a = 1, \dots, d$, $j_a \in J \sqcup \{\emptyset\}$ is uniquely determined if at least one of i_a and k_a is not \emptyset . Thus only we can choose is the positions of $j \in J$ correspond to orphans $(\emptyset, j, \emptyset) \in u$. The number of them is $\#u - \#\pi_{1,3}(u)$ and we can place them in $d - \#\pi_{1,3}(u)$ distinct positions. So the number of choices is $P_u(d) = (d - \#\pi_{1,3}(u)) \cdots (d - \#u + 1)$. \square

We remark that in the composition law above the rank d only appears as polynomials in the coefficients. So we can change $d \in \mathbb{N}$ into an arbitrary $t \in k$. This is the definition of our category $\mathcal{S}_t(\mathcal{C})$.

Definition 4.10. Let \mathcal{C} be a k -linear category with unit and $t \in k$. We define the k -linear category $\mathcal{S}_t(\mathcal{C})$ by taking the pseudo-abelian envelope of the category defined as follows:

Object A finite family of objects in \mathcal{C} written as $\langle U_I \rangle_t$ for $U_I = (U_i)_{i \in I}$. We also write $\langle U_I \rangle_t = \langle U_{i_1}, \dots, U_{i_m} \rangle_t$ when $I = \{i_1, \dots, i_m\}$.

Morphism For objects $\langle U_I \rangle_t$ and $\langle V_J \rangle_t$,

$$\text{Hom}_{\mathcal{S}_t(\mathcal{C})}(\langle U_I \rangle_t, \langle V_J \rangle_t) \simeq H(U_I; V_J).$$

For each $\Phi \in H(U_I; V_J)$, we denote by $\langle \Phi \rangle_t$ the corresponding morphism in $\mathcal{S}_t^0(\mathcal{C})$. The composition of morphisms is given by

$$\langle \Psi \rangle_t \circ \langle \Phi \rangle_t := \sum_{u \in R(s \circ r)} P_u(t) \langle \Psi \circ_u \Phi \rangle_t$$

for each $\Phi \in H_r(U_I; V_J)$, $\Psi \in H_s(V_J; W_K)$.

The unit object $\mathbb{1}_{\mathcal{S}_t(\mathcal{C})}$ of $\mathcal{S}_t(\mathcal{C})$ is the object $\langle \rangle_t$ corresponding to the empty family.

Lemma 4.11. *The category $\mathcal{S}_t(\mathcal{C})$ is well-defined; that is, there are identity morphisms and the composition of morphisms is associative.*

Proof. The identity morphism of $\langle U_I \rangle_t$ is given by

$$\left\langle \bigotimes_{i \in I} id_{U_i} \right\rangle_t \in \langle H_{r_I}(U_I; U_I) \rangle_t$$

where $r_I = \{(i, i) \mid i \in I\} \in R(I, I)$. To prove associativity, we first prove the case for replacing k with the polynomial ring $k[T]$ and t with the indeterminate $T \in k[T]$. Let $\Phi \in H(U_I; V_J)$, $\Psi \in H(V_J; W_K)$ and $\Theta \in H(W_K; X_L)$. Set

$$\langle \mathcal{T} \rangle_T = (\langle \Theta \rangle_T \circ \langle \Psi \rangle_T) \circ \langle \Phi \rangle_T - \langle \Theta \rangle_T \circ (\langle \Psi \rangle_T \circ \langle \Phi \rangle_T).$$

For all $d \in \mathbb{N}$, we have $[\mathcal{T}]_{T=d} = 0$ by Lemma 4.9. Since $[\bullet]_d$ is an isomorphism when $d \geq \#I + \#L$, we have $\mathcal{T}_{T=d} = 0$ for such d . Thus $\mathcal{T} = 0$ and we get the associativity for $t \in k$ by substituting $T = t$. \square

Definition 4.12. For a functor $F : \mathcal{C} \rightarrow \mathcal{D}$ with unit, let $\mathcal{S}_t(F)$ be the functor $\mathcal{S}_t(\mathcal{C}) \rightarrow \mathcal{S}_t(\mathcal{D})$ with unit which sends $\langle U_I \rangle_t$ to $\langle F(U_I) \rangle_t$ and $\langle \Phi \rangle_t$ to $\langle F(\Phi) \rangle_t$. For a k -linear transformation $\eta : F \rightarrow G$ with unit, let us define the k -linear transformation $\mathcal{S}_t(\eta) : \mathcal{S}_t(F) \rightarrow \mathcal{S}_t(G)$ with unit by

$$\mathcal{S}_t(\eta)(\langle U_I \rangle_t) := \left\langle \bigotimes_{i \in I} \eta(U_i) \right\rangle_t \in \langle H_{r_I}(F(U_I); G(U_I)) \rangle_t$$

where $r_I = \{(i, i) \mid i \in I\} \in R(I, I)$. These operations define a 2-functor $\mathcal{S}_t : \mathbb{1}\text{-PsCat}_k \rightarrow \mathbb{1}\text{-PsCat}_k$ where $\mathbb{1}\text{-PsCat}_k$ is defined as same as before.

Now the following statements are obvious.

Theorem 4.13. Let $d \in \mathbb{N}$. For finite families U_I, V_J of objects in \mathcal{C} , the map

$$\begin{aligned} \text{Hom}_{\mathcal{S}_d(\mathcal{C})}(\langle U_I \rangle_d, \langle V_J \rangle_d) &\rightarrow \text{Hom}_{\mathcal{W}_d(\mathcal{C})}([U_I]_d, [V_J]_d) \\ \langle \Phi \rangle_d &\mapsto [\Phi]_d \end{aligned}$$

is surjective and its kernel is $\langle H^{>d}(U_I; V_J) \rangle_d$. In particular, it is an isomorphism when $d \geq \#I + \#J$. This map induces a functor $\mathcal{S}_d(\mathcal{C}) \rightarrow \mathcal{W}_d(\mathcal{C})$; $\langle U_I \rangle_d \mapsto [U_I]_d$. If $d!$ is invertible in k , this functor is also essentially surjective on objects.

Remark 4.14. Deligne’s category $\text{Rep}(\mathcal{S}_t, k)$ in [5] is equal to $\mathcal{S}_t(\text{Triv}_k)$, in our language. Since $\mathcal{S}_t(\mathcal{C}) \simeq \mathcal{S}_t(\mathcal{P}_s(\mathcal{C}))$, this is also equivalent to $\mathcal{S}_t(\mathcal{R}ep(k))$. Its generalization $\text{Rep}(G \wr \mathcal{S}_t, k)$ for a finite group G by Knop [10,11] is equivalent to the full subcategory of $\mathcal{S}_t(\mathcal{R}ep(k[G]))$ generated by $\langle k[G] \rangle_t^{\otimes m}$ where $k[G]$ is the regular representation of G .

4.2. \mathcal{S}_t for tensor categories

When \mathcal{C} is a k -tensor category, we can calculate the tensor product of objects of the form $[U_I]_d$ in the same manner as in the previous subsection. It holds for families U_I and V_J that

$$[U_I]_d \otimes [V_J]_d \simeq \bigoplus_{\substack{r \in R(I, J) \\ \#r \leq d}} [T_r(U_I, V_J)]_d \simeq \bigoplus_{r \in R(I, J)} [T_r(U_I, V_J)]_d.$$

Here, for each $r \in R(I, J)$, $T_r(U_I, V_J)$ is the family

$$T_r(U_I, V_J) := (U_i \otimes V_j)_{(i, j) \in r}$$

indexed by the set $r = \{(i, j), \dots\}$. Remark that there is a bijection

$$R(I, J, K, L) \xleftarrow{1:1} \bigsqcup_{\substack{r \in R(I, J) \\ s \in R(K, L)}} R(r, s)$$

where $R(r, s)$ denotes the set of recollements between the sets $r = \{(i, j), \dots\}$ and $s = \{(k, l), \dots\}$. Via this bijection a recollement $u \in R(I, J, K, L)$ correspond to $u' \in R(\pi_{1,2}(u), \pi_{3,4}(u))$ which satisfies $((i, j), (k, l)) \in u'$ if and only if $(i, j, k, l) \in u$. So using this bijection the morphisms between tensor products are given by

$$\text{Hom}_{\mathcal{W}_d(\mathcal{C})}([U_I]_d \otimes [V_J]_d, [W_K]_d \otimes [X_L]_d) \simeq \bigoplus_{\substack{u \in R(I, J, K, L) \\ \#u \leq d}} H_u(U_I, V_J; W_K, X_L)$$

where for each $u \in R(I, J, K, L)$,

$$\begin{aligned}
 H_u(U_I, V_J; W_K, X_L) &:= H_{u'}(T_{\pi_{1,2}(u)}(U_I, V_J); T_{\pi_{3,4}(u)}(W_K, X_L)) \\
 &\simeq \bigotimes_{(i,j,k,l) \in u} \text{Hom}_{\mathcal{C}}(U_i \otimes V_j, W_k \otimes X_l).
 \end{aligned}$$

The proof of the next lemma is same as that of Lemma 4.9.

Lemma 4.15. For $\Phi \in H_r(U_I; W_K)$ and $\Psi \in H_s(V_J; X_L)$,

$$[\Phi]_d \otimes [\Psi]_d = \sum_{u \in R(r \otimes s)} [\Phi \otimes_u \Psi]_d.$$

Here,

$$R(r \otimes s) := \{u \in R(I, J, K, L) \mid \pi_{1,3}(u) = r, \pi_{2,4}(u) = s\}$$

and $\Phi \otimes_u \Psi \in H_u(U_I, V_J; W_K, X_L)$ is obtained by composing terms of $\Phi \otimes \Psi$ using tensor products

$$\text{Hom}_{\mathcal{C}}(U_i, W_k) \otimes \text{Hom}_{\mathcal{C}}(V_j, X_l) \rightarrow \text{Hom}_{\mathcal{C}}(U_i \otimes V_j, W_k \otimes X_l)$$

for all $(i, j, k, l) \in u$.

Definition 4.16. We define tensor products on $\mathcal{S}_t(\mathcal{C})$ in the same manner as above: for families U_I and V_J of objects in \mathcal{C} ,

$$\langle U_I \rangle_t \otimes \langle V_J \rangle_t := \bigoplus_{r \in R(I, J)} \langle T_r(U_I, V_J) \rangle_t$$

and for morphisms $\Phi \in H_r(U_I; W_K)$ and $\Psi \in H_s(V_J; X_L)$,

$$\langle \Phi \rangle_t \otimes \langle \Psi \rangle_t := \sum_{u \in R(r \otimes s)} \langle \Phi \otimes_u \Psi \rangle_t.$$

This tensor product induces a structure of k -tensor category to $\mathcal{S}_t(\mathcal{C})$ and we have an enriched 2-functor $\mathcal{S}_t: \otimes\text{-Cat}_k \rightarrow \otimes\text{-PsCat}_k$. For $d \in \mathbb{N}$, $\mathcal{S}_d(\mathcal{C}) \rightarrow \mathcal{W}_d(\mathcal{C})$ induces a k -tensor functor.

The generalized formula for m -fold tensor products is as follows. The symbols

$$\begin{aligned}
 &T_r(U_{I_1}, \dots, U_{I_m}) \quad \text{for } r \in R(I_1, \dots, I_m), \\
 &H_r(U_{I_1}, \dots, U_{I_m}; V_{J_1}, \dots, V_{J_n}) \quad \text{for } r \in R(I_1, \dots, I_m, J_1, \dots, J_n)
 \end{aligned}$$

are defined in the same manner as in the case $m = n = 2$.

Lemma 4.17. Let $U_{I_1}, \dots, U_{I_m}, V_{J_1}, \dots, V_{J_n}$ be families of objects in \mathcal{C} . Then

$$\begin{aligned}
 \langle U_{I_1} \rangle_t \otimes \dots \otimes \langle U_{I_m} \rangle_t &\simeq \bigoplus_{r \in R(I_1, \dots, I_m)} \langle T_r(U_{I_1}, \dots, U_{I_m}) \rangle_t, \\
 \text{Hom}_{\mathcal{S}_t(\mathcal{C})}(\langle U_{I_1} \rangle_t \otimes \dots \otimes \langle U_{I_m} \rangle_t, \langle V_{J_1} \rangle_t \otimes \dots \otimes \langle V_{J_n} \rangle_t) \\
 &\simeq \bigoplus_{r \in R(I_1, \dots, I_m, J_1, \dots, J_n)} \langle H_r(U_{I_1}, \dots, U_{I_m}; V_{J_1}, \dots, V_{J_n}) \rangle_t.
 \end{aligned}$$

By specializing it to the case that the all families are of size one, we get:

Corollary 4.18. For $U_1, \dots, U_m, V_1, \dots, V_n \in \mathcal{C}$,

$$\begin{aligned} \langle U_1 \rangle_t \otimes \dots \otimes \langle U_m \rangle_t &\simeq \bigoplus_{p \in P(m)} \langle T_p(U_1, \dots, U_m) \rangle_t, \\ \text{Hom}_{\mathcal{S}_t(\mathcal{C})}(\langle U_1 \rangle_t \otimes \dots \otimes \langle U_m \rangle_t, \langle V_1 \rangle_t \otimes \dots \otimes \langle V_n \rangle_t) \\ &\simeq \bigoplus_{p \in P(m,n)} \langle H_p(U_1, \dots, U_m; V_1, \dots, V_n) \rangle_t. \end{aligned}$$

Here $P(m) = P(\{1, \dots, m\})$ and $P(m, n) := P(\{1, \dots, m\} \sqcup \{1', \dots, n'\})$.

Note that the object $\langle U_1, \dots, U_m \rangle_t$ is obtained as a direct summand of $\langle U_1 \rangle_t \otimes \dots \otimes \langle U_m \rangle_t$ by the corollary above. Thus $\mathcal{S}_t(\mathcal{C})$ is also generated by objects of this form.

4.3. Base change

Let $r \in R(I, J)$ be a recollement between finite sets I and J . As before, we regard r as a set $r = \{(i, j), \dots\}$. This set is naturally identified with the pushout $I \sqcup J / \sim_r$. Conversely, for such r , let us denote by \bar{r} the pullback

$$\bar{r} := \{(i, j) \in I \times J \mid i \sim_r j\} = \{(i, j) \in r \mid i, j \neq \emptyset\}.$$

So I, J, r and \bar{r} form a cartesian and cocartesian square

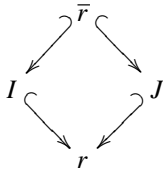

in the category of finite sets. Remark that there are bijections

$$\begin{aligned} R(I, J) \\ &\xleftrightarrow{1:1} \{\text{set } r \text{ with injective maps } I \hookrightarrow r, J \hookrightarrow r \text{ such that } I \sqcup J \rightarrow r \text{ is surjective}\} / \sim \\ &\xleftrightarrow{1:1} \{\text{set } \bar{r} \text{ with injective maps } \bar{r} \hookrightarrow I, \bar{r} \hookrightarrow J\} / \sim. \end{aligned}$$

Let U_I, V_J be families of objects in \mathcal{C} . Take a recollement $r \in R(I, J)$ and write

$$r = \{(i, j), \dots, (i', \emptyset), \dots, (\emptyset, j'), \dots\}$$

where $i, i', \dots \in I$ and $j, j', \dots \in J$. Using this representation, let us write

$$U_I = (U_i, \dots, U_{i'}, \dots), \quad V_J = (V_j, \dots, V_{j'}, \dots).$$

respectively. Let us introduce four families

$$\begin{aligned} U_r &:= (U_i, \dots, U_{i'}, \dots, V_{j'}, \dots), & U_{\bar{r}} &:= (U_i, \dots), \\ V_r &:= (V_j, \dots, U_{i'}, \dots, V_{j'}, \dots), & V_{\bar{r}} &:= (V_j, \dots) \end{aligned}$$

indexed by the sets r and \bar{r} respectively.

Take an element $\Phi \in H_r(U_I; V_J)$ of the form

$$\Phi = \varphi_{i,j}^{(1)} \otimes \dots \otimes \varphi_{i'}^{(2)} \otimes \dots \otimes \varphi_{j'}^{(3)} \otimes \dots$$

where $\varphi_{i,j}^{(1)}: U_i \rightarrow V_j, \varphi_{i'}^{(2)}: U_{i'} \rightarrow \mathbb{1}_C$ and $\varphi_{j'}^{(3)}: \mathbb{1}_C \rightarrow V_{j'}$. By the composition law in $\mathcal{S}_t(C)$, we have that the map $\langle \Phi \rangle_t: \langle U_I \rangle_t \rightarrow \langle V_J \rangle_t$ factors through $\langle U_r \rangle_t$ and $\langle V_r \rangle_t$; that is, the composite

$$\begin{array}{ccc} \langle U_I \rangle_t & & \langle V_J \rangle_t \\ \searrow & & \nearrow \\ \langle \dots \otimes \varphi_{j'}^{(3)} \otimes \dots \rangle_t & \langle U_r \rangle_t \xrightarrow{\langle \dots \otimes \varphi_{i,j}^{(1)} \otimes \dots \rangle_t} \langle V_r \rangle_t & \langle \dots \otimes \varphi_{i'}^{(2)} \otimes \dots \rangle_t \end{array}$$

is equal to $\langle \Phi \rangle_t$. Now let us consider another composite which goes through $\langle U_{\bar{r}} \rangle_t$ and $\langle V_{\bar{r}} \rangle_t$:

$$\begin{array}{ccc} & \langle U_{\bar{r}} \rangle_t \xrightarrow{\langle \dots \otimes \varphi_{i,j}^{(1)} \otimes \dots \rangle_t} \langle V_{\bar{r}} \rangle_t & \\ \nearrow & & \searrow \\ \langle \dots \otimes \varphi_{i'}^{(2)} \otimes \dots \rangle_t & & \langle \dots \otimes \varphi_{j'}^{(3)} \otimes \dots \rangle_t \\ \langle U_I \rangle_t & & \langle V_J \rangle_t \end{array}$$

We denote this morphism by the symbol $\langle\langle \Phi \rangle\rangle_t$. By the composition law, we get the formula

$$\langle\langle \Phi \rangle\rangle_t = \sum_{s \leq r} \langle \Phi|_s \rangle_t$$

immediately. Here, for each recollement $s \leq r$, $\Phi|_s \in H_s(U_I; V_J)$ is obtained by composing terms of Φ using

$$Hom_C(U_i, \mathbb{1}_C) \otimes Hom_C(\mathbb{1}_C, V_j) \rightarrow Hom_C(U_i, V_j)$$

for each $i \in I$ and $j \in J$ such that $i \approx_r j$ but $i \not\sim_s j$. Thus we have another isomorphism $\langle\langle \bullet \rangle\rangle_t: H(U_I; V_J) \rightarrow Hom_{\mathcal{S}_t(C)}(\langle U_I \rangle_t, \langle V_J \rangle_t)$ and morphisms of the form $\langle\langle \Phi \rangle\rangle_t$ also form a basis of $Hom_{\mathcal{S}_t(C)}(\langle U_I \rangle_t, \langle V_J \rangle_t)$.

Conversely, we can explicitly represent a morphism of the form $\langle \Phi \rangle_t$ as a linear combination of morphisms $\langle\langle \Psi \rangle\rangle_t$. For each recollements $s \leq r$, their Möbius function is given by $\mu(s, r) = (-1)^{\#r - \#s}$ since the subset $\{u \in R(I, J) \mid s \leq u \leq r\}$ is isomorphic to the power set of a set of order $\#r - \#s$ as partially ordered set. Thus we have the inverse formula

$$\langle \Phi \rangle_t = \sum_{s \leq r} (-1)^{\#r - \#s} \langle\langle \Phi|_s \rangle\rangle_t.$$

Now let us take two morphisms $\langle\langle \Phi \rangle\rangle_t: \langle U_I \rangle_t \rightarrow \langle V_J \rangle_t$ and $\langle\langle \Psi \rangle\rangle_t: \langle V_J \rangle_t \rightarrow \langle W_K \rangle_t$ and calculate the composite of them. Let $\Phi \in H_r(U_I; V_J)$ and $\Psi \in H_s(V_J; W_K)$ be

$$\begin{aligned} \Phi &= \varphi_{i,j}^{(1)} \otimes \dots \otimes \varphi_{i'}^{(2)} \otimes \dots \otimes \varphi_{j'}^{(3)} \otimes \dots \\ \Psi &= \psi_{j,k}^{(1)} \otimes \dots \otimes \psi_{j'}^{(2)} \otimes \dots \otimes \psi_{k'}^{(3)} \otimes \dots \end{aligned}$$

as same as before. Let $J_1 \subset J$ be the union of images $\bar{r} \hookrightarrow J$ and $\bar{s} \hookrightarrow J$ and denote by V_{J_1} the subfamily of V_J indexed by J_1 . By the composition law, the composite $\langle V_{\bar{r}} \rangle_t \rightarrow \langle V_J \rangle_t \rightarrow \langle V_{\bar{s}} \rangle_t$ is equal to the scalar multiple of the composite $\langle V_{\bar{r}} \rangle_t \rightarrow \langle V_{J_1} \rangle_t \rightarrow \langle V_{\bar{s}} \rangle_t$. Here, its scalar coefficient is given by

$$P_{r,s}(t) \prod_{j' \in J \setminus J_1} \psi_{j'}^{(2)} \circ \varphi_{j'}^{(3)}$$

where $P_{r,s}$ is the polynomial

$$P_{r,s}(T) := \prod_{\#J_1 \leq a < \#J} (T - a) = (T - \#J_1) \cdots (T - \#J + 1)$$

and we regard each $\psi_{j'}^{(2)} \circ \varphi_{j'}^{(3)} : \mathbb{1}_{\mathcal{C}} \rightarrow V_{j'} \rightarrow \mathbb{1}_{\mathcal{C}}$ as scalar via $\text{End}_{\mathcal{C}}(\mathbb{1}_{\mathcal{C}}) \simeq k$. Then we can complete the square

$$\begin{array}{ccccc} & & \langle V_{\bar{u}} \rangle_t & & \\ & \nearrow & \text{---} & \searrow & \\ \cdots & \rightarrow & \langle V_{\bar{r}} \rangle_t & & \langle V_{\bar{s}} \rangle_t \rightarrow \cdots \\ & \searrow & & \nearrow & \\ & & \langle V_{J_1} \rangle_t & & \end{array}$$

using the base change formula. To apply the formula, we regard $J_1 \in R(\bar{r}, \bar{s})$ via the injective maps $\bar{r} \hookrightarrow J_1$ and $\bar{s} \hookrightarrow J_1$. The sum is taken over all recollements $u \in R(\bar{r}, \bar{s})$ such that $u \leq J_1$. Taken together, we obtain the formula in the next proposition.

For $u \in R(\bar{r}, \bar{s})$, let us denote by $u' \in R(I, K)$ the induced recollement on I and K by the injective maps $\bar{u} \hookrightarrow \bar{r} \hookrightarrow I$ and $\bar{u} \hookrightarrow \bar{s} \hookrightarrow K$. Let $s \circ r$ be the maximal element of $R(s \circ r)$, i.e. the equivalent relation on $I \sqcup J \sqcup K$ generated by r and s , so $J'_1 = \pi_{1,3}(s \circ r)$.

Proposition 4.19. *Let $r \in R(I, J)$, $s \in R(J, K)$, $\Phi \in H_r(U_I; V_J)$ and $\Psi \in H_s(V_J, W_K)$ as above. Put $\Xi := \Psi \circ_{(s \circ r)} \Phi \in H_{J'_1}(H_I, W_K)$. Then*

$$\langle \langle \Psi \rangle \rangle_t \circ \langle \langle \Phi \rangle \rangle_t = P_{r,s}(t) \sum_{u \leq J_1} (-1)^{\#J_1 - \#u} \langle \langle \Xi|_{u'} \rangle \rangle_t.$$

The inequality $\#\bar{r}, \#\bar{s} \geq \#\bar{u} = \#u'$ for r, s and u above gives us the next corollary.

Corollary 4.20. *Let U_I, V_J and W_K be families of objects in \mathcal{C} . Take $d, e \in \mathbb{N}$ and let $f := \max\{d + \#K, e + \#I\} - \#J$. Then*

$$\langle \langle H^{\geq e}(V_J, W_K) \rangle \rangle_t \circ \langle \langle H^{\geq d}(U_I, V_J) \rangle \rangle_t \subset \langle \langle H^{\geq f}(U_I, W_K) \rangle \rangle_t.$$

In particular, $\langle \langle H^{\geq d}(U_I, U_I) \rangle \rangle_t$ is a two-sided ideal of $\text{End}_{\mathcal{S}_t(\mathcal{C})}(\langle \langle U_I \rangle \rangle_t)$ for any d .

4.4. Restriction and induction

We also interpolate the restriction functors defined in Section 3.5 to arbitrary ranks.

Definition 4.21. Let \mathcal{C} be a k -linear category with unit and $t_1, t_2 \in k$. Put $t = t_1 + t_2$. We define the functor $\text{Res}_{\mathfrak{S}_{t_1} \times \mathfrak{S}_{t_2}}^{\mathfrak{S}_t} : \mathcal{S}_t(\mathcal{C}) \rightarrow \mathcal{S}_{t_1}(\mathcal{C}) \boxtimes \mathcal{S}_{t_2}(\mathcal{C})$ by

$$\text{Res}_{\mathfrak{S}_{t_1} \times \mathfrak{S}_{t_2}}^{\mathfrak{S}_t}(\langle \langle U_I \rangle \rangle_t) := \bigoplus_{I' \subset I} \langle \langle U_{I'} \rangle \rangle_{t_1} \boxtimes \langle \langle U_{I \setminus I'} \rangle \rangle_{t_2}.$$

The map for morphisms is defined as follows. Fix subsets $I' \subset I$ and $J' \subset J$ and take $r \in R(I, J)$. Let $r' \in R(I', J')$ and $r'' \in R(I \setminus I', J \setminus J')$ be the restricted recollements of r to each subsets. Then

$$H_{r'}(U_{I'}; V_{J'}) \otimes H_{r''}(U_{I \setminus I'}; V_{J \setminus J'}) \simeq H_{r' \sqcup r''}(U_I; V_J).$$

Here $r \sqcup r' \in R(I, J)$ is the equivalence relation generated by r and r' . For each $\Phi \in H_r(U_I, V_J)$, the matrix entry of $Res_{\mathfrak{S}_{t_1} \times \mathfrak{S}_{t_2}}^{\mathfrak{S}_t}(\langle \Phi \rangle_t)$ at the cell

$$\langle U_{I'} \rangle_{t_1} \boxtimes \langle U_{I \setminus I'} \rangle_{t_2} \rightarrow \langle V_{J'} \rangle_{t_1} \boxtimes \langle V_{J \setminus J'} \rangle_{t_2}$$

is defined to be zero if $r \neq r' \sqcup r''$; otherwise $\sum \langle \Phi' \rangle_{t_1} \boxtimes \langle \Phi'' \rangle_{t_2}$ when we write $\Phi = \sum \Phi' \otimes \Phi''$ using $\Phi' \in H_{r'}(U_{I'}; V_{J'})$ and $\Phi'' \in H_{r''}(U_{I \setminus I'}; V_{J \setminus J'})$.

Definition 4.22. Let \mathcal{C} be a k -linear category with unit, $t_1, t_2 \in k$ and put $t = t_1 t_2$. We define the functor $Res_{\mathfrak{S}_{t_1} \wr \mathfrak{S}_{t_2}}^{\mathfrak{S}_t} : \mathcal{S}_t(\mathcal{C}) \rightarrow \mathcal{S}_{t_2}(\mathcal{S}_{t_1}(\mathcal{C}))$ by

$$Res_{\mathfrak{S}_{t_1} \wr \mathfrak{S}_{t_2}}^{\mathfrak{S}_t}(\langle U_I \rangle_t) := \bigoplus_{p \in P(I)} \langle U_p \rangle_{t_1} \rangle_{t_2}.$$

Here, p runs over all partitions of I and $\langle U_p \rangle_{t_1}$ is the family of objects in $\mathcal{S}_{t_1}(\mathcal{C})$ indexed by $p = \{I_1, \dots, I_l\}$:

$$\langle U_p \rangle_{t_1} := (\langle U_{I_1} \rangle_{t_1}, \dots, \langle U_{I_l} \rangle_{t_1}).$$

The map for morphisms is defined in the same manner; the matrix entry of $Res_{\mathfrak{S}_{t_1} \wr \mathfrak{S}_{t_2}}^{\mathfrak{S}_t}(\langle \Phi \rangle_t)$ for $\Phi \in H_r(U_I, V_J)$ at the cell

$$\langle \langle U_p \rangle_{t_1} \rangle_{t_2} \rightarrow \langle \langle V_q \rangle_{t_1} \rangle_{t_2}$$

is induced from Φ if r is compatible with p, q and otherwise zero.

The well-definedness of these functors is proved by the same argument as the previous one: consider the case for the indeterminate rank $T \in k[T]$ and check that equations hold for all $T = d \gg 0$ in $\mathcal{W}_d(\mathcal{C})$. Note that for a k -braided tensor category \mathcal{C} , it is easier to define them using the universality of $\mathcal{S}_t(\mathcal{C})$, see [Theorem 4.31](#).

On the other hand, it does not seem possible to interpolate the induction functors to general $t_1, t_2 \in k$. For example, if the functor $Ind_{\mathfrak{S}_{t_1} \times \mathfrak{S}_{t_2}}^{\mathfrak{S}_t}$ exists it should multiply “dimensions” of objects by the binomial coefficient $t!/(t_1!t_2!)$, which is not a polynomial in t_1, t_2 . However, in the special case where one of the parameters $t_2 = d_2 \in \mathbb{N}$ is a natural number and $d_2!$ is invertible in k , we can define associative $*$ -product by

$$\begin{aligned} \mathcal{S}_{t_1}(\mathcal{C}) \overline{\boxtimes} \mathcal{W}_{d_2}(\mathcal{C}) &\rightarrow \mathcal{S}_{t_1+d_2}(\mathcal{C}) \\ \langle U_1, \dots, U_m \rangle_{t_1} \boxtimes [V_1, \dots, V_{d_2}]_{d_2} &\mapsto \langle U_1, \dots, U_m, V_1, \dots, V_{d_2} \rangle_{t_1+d_2} \end{aligned}$$

since $\mathcal{W}_{d_2}(\mathcal{C})$ is generated by objects of this form. This defines the action of k -tensor category $\mathcal{W}_\bullet(\mathcal{C})$ on $\mathcal{S}_\bullet(\mathcal{C}) := \bigoplus_{t \in k} \mathcal{S}_t(\mathcal{C})$.

4.5. \mathcal{S}_t for braided tensor categories

If a k -tensor category \mathcal{C} has a braiding $\sigma_{\mathcal{C}}$ then the 2-functor \mathcal{S}_t naturally induces a braiding $\sigma_{\mathcal{S}_t(\mathcal{C})}$ of $\mathcal{S}_t(\mathcal{C})$. Here its component $\langle U_I \rangle_t \otimes \langle V_J \rangle_t \xrightarrow{\sim} \langle V_J \rangle_t \otimes \langle U_I \rangle_t$ is the direct sum of isomorphisms

$$\left\langle \bigotimes_{(i,j) \in r} \sigma_{\mathcal{C}}(U_i, V_j) \right\rangle_t : \langle T_r(U_I, V_J) \rangle_t \xrightarrow{\sim} \langle T_{\bar{r}}(V_J, U_I) \rangle_t$$

for all $r \in R(I, J)$ where $\tilde{r} \in R(J, I)$ is the corresponding recollement to r via $I \sqcup J \xleftarrow{1:1} J \sqcup I$. Clearly if the braiding $\sigma_{\mathcal{C}}$ is symmetric then so is $\sigma_{\mathcal{S}_t(\mathcal{C})}$.

As we have seen, it is too complicated to describe the morphisms in $\mathcal{S}_t(\mathcal{C})$. But if a braiding $\sigma_{\mathcal{C}}$ of the category \mathcal{C} is given, we can use a very powerful tool: the graphical representation of morphisms. First we represent object $\langle U_1 \rangle_t \otimes \cdots \otimes \langle U_m \rangle_t$ by labeled points placed side-by-side:

$$\langle U_1 \rangle_t \otimes \cdots \otimes \langle U_m \rangle_t = \begin{matrix} U_1 & U_2 & \cdots & U_m \\ \bullet & \bullet & \cdots & \bullet \end{matrix}.$$

When $m = 0$, “no points” denotes the unit object $\mathbb{1}_{\mathcal{S}_t(\mathcal{C})}$. Recall that objects of this form generate the pseudo-abelian category $\mathcal{S}_t(\mathcal{C})$; so to describe $\mathcal{S}_t(\mathcal{C})$ it suffices to consider morphisms between them. We represent such morphisms by strings which connect points from top to bottom.

For each morphism $\varphi: U \rightarrow V$ in \mathcal{C} , we have $\langle \varphi \rangle_t: \langle U \rangle_t \rightarrow \langle V \rangle_t$. We represent it by a string with a label $\boxed{\varphi}$. If $\varphi = id_U: U \rightarrow U$, the label may be omitted:

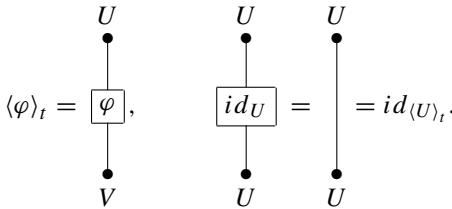

By definition, the spaces of morphisms $\mathbb{1}_{\mathcal{S}_t(\mathcal{C})} \rightarrow \langle \mathbb{1}_{\mathcal{C}} \rangle_t$ and $\langle \mathbb{1}_{\mathcal{C}} \rangle_t \rightarrow \mathbb{1}_{\mathcal{S}_t(\mathcal{C})}$ are both isomorphic to $End_{\mathcal{C}}(\mathbb{1}_{\mathcal{C}})$. Take morphisms $\iota_{\mathcal{C}}$ and $\epsilon_{\mathcal{C}}$ from them respectively which correspond to $id_{\mathbb{1}_{\mathcal{C}}}$. We represent them by broken strings:

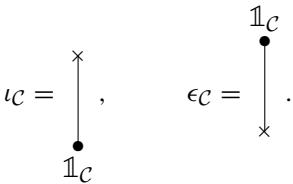

As we have seen, $\langle U \otimes V \rangle_t$ is a direct summand of $\langle U \rangle_t \otimes \langle V \rangle_t$. We denote its retraction by $\mu_{\mathcal{C}}(U, V): \langle U \rangle_t \otimes \langle V \rangle_t \rightarrow \langle U \otimes V \rangle_t$ and section $\Delta_{\mathcal{C}}(U, V): \langle U \otimes V \rangle_t \rightarrow \langle U \rangle_t \otimes \langle V \rangle_t$. We represent them by ramifications of strings:

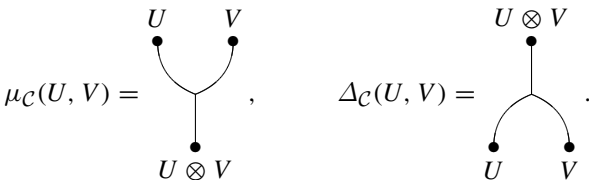

Let us denote by $\tau_{\mathcal{C}}(U, V)$ the braiding $\sigma_{\mathcal{S}_t(\mathcal{C})}(\langle U \rangle_t, \langle V \rangle_t): \langle U \rangle_t \otimes \langle V \rangle_t \xrightarrow{\sim} \langle V \rangle_t \otimes \langle U \rangle_t$ for short. This morphism is represented by crossing strings. We distinguish the braiding from its

inverse by the sign of the crossing, the overpass and the underpass:

$$\tau_{\mathcal{C}}(U, V) = \begin{array}{c} U \quad V \\ \bullet \quad \bullet \\ \diagdown \quad \diagup \\ \bullet \quad \bullet \\ V \quad U \end{array}, \quad \tau_{\mathcal{C}}^{-1}(U, V) = \begin{array}{c} U \quad V \\ \bullet \quad \bullet \\ \diagup \quad \diagdown \\ \bullet \quad \bullet \\ V \quad U \end{array}.$$

We represent the tensor product of these morphisms by placing corresponding diagrams side-by-side. Finally we connect these diagrams from top to bottom to represent the composite of them.

Example 4.23. The diagram in the introduction

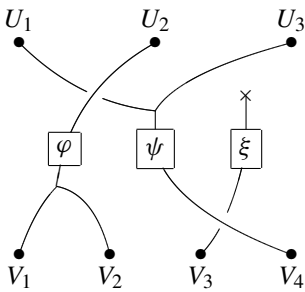

denotes the composite of morphisms

$$\begin{aligned} \langle U_1 \rangle_t \otimes \langle U_2 \rangle_t \otimes \langle U_3 \rangle_t &\xrightarrow{\tau_{\mathcal{C}}^{-1}(U_1, U_2) \otimes id_{\langle U_3 \rangle_t}} \langle U_2 \rangle_t \otimes \langle U_1 \rangle_t \otimes \langle U_3 \rangle_t \\ &\xrightarrow{id_{\langle U_2 \rangle_t} \otimes \mu_{\mathcal{C}}(U_1, U_3) \otimes id_{\mathcal{C}}} \langle U_2 \rangle_t \otimes \langle U_1 \otimes U_3 \rangle_t \otimes \langle \mathbb{1}_{\mathcal{C}} \rangle_t \\ &\xrightarrow{\langle \varphi \rangle_t \otimes \langle \psi \rangle_t \otimes \langle \xi \rangle_t} \langle V_1 \otimes V_2 \rangle_t \otimes \langle V_4 \rangle_t \otimes \langle V_3 \rangle_t \\ &\xrightarrow{\Delta_{\mathcal{C}}(V_1, V_2) \otimes id_{\langle V_4 \rangle_t} \otimes id_{\langle V_3 \rangle_t}} \langle V_1 \rangle_t \otimes \langle V_2 \rangle_t \otimes \langle V_4 \rangle_t \otimes \langle V_3 \rangle_t \\ &\xrightarrow{id_{\langle V_1 \rangle_t} \otimes id_{\langle V_2 \rangle_t} \otimes \tau_{\mathcal{C}}(V_4, V_3)} \langle V_1 \rangle_t \otimes \langle V_2 \rangle_t \otimes \langle V_3 \rangle_t \otimes \langle V_4 \rangle_t \end{aligned}$$

for $\varphi: U_2 \rightarrow V_1 \otimes V_2$, $\psi: U_1 \otimes U_3 \rightarrow V_4$ and $\xi: \mathbb{1}_{\mathcal{C}} \rightarrow V_3$.

Recall that we can decompose the space of morphisms

$$\langle U_1 \rangle_t \otimes \cdots \otimes \langle U_m \rangle_t \rightarrow \langle V_1 \rangle_t \otimes \cdots \otimes \langle V_n \rangle_t$$

by partitions $P(m, n)$ as in Corollary 4.18. It is easy to show that if we take the morphism represented by the diagram above, this morphism is decomposed as

$$\sum_{q \leq p} \langle \Theta_q \rangle_t$$

using suitable $\Theta_q \in H_q(U_1, \dots, U_3; V_1, \dots, V_4)$ for each $q \leq p$ where $p \in P(3, 4)$ is a partition $\{\{2, 1', 2'\}, \{1, 3, 4'\}, \{3'\}\}$. Moreover, the top component Θ_p is equal to $\varphi \otimes \psi \otimes \xi$.

To apply this argument globally, we have to fix a “shape” of each partition. For example,

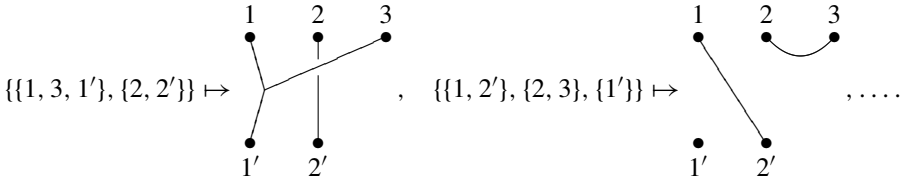

Let us describe it more precisely. For each partition $p \in P(m, n)$, first we fix an order of the components $p = \{I_1, \dots, I_l\}$. For each $k = 1, \dots, l$, write

$$I_k = \{i_{k,1}, i_{k,2}, \dots, i_{k,a(k)}, j'_{k,1}, j'_{k,2}, \dots, j'_{k,b(k)}\}$$

so that $i_{k,1} < i_{k,2} < \dots < i_{k,a(k)}$ and $j_{k,1} < j_{k,2} < \dots < j_{k,b(k)}$. Next we choose braid group elements $g \in \mathfrak{B}_m$ and $h \in \mathfrak{B}_n$ which satisfy

$$\begin{aligned} (g^{-1}(1), \dots, g^{-1}(m)) &= (i_{1,1}, i_{1,2}, \dots, i_{1,a(1)}, \dots, i_{l,1}, i_{l,2}, \dots, i_{l,a(l)}), \\ (h^{-1}(1), \dots, h^{-1}(n)) &= (j_{1,1}, j_{1,2}, \dots, j_{1,b(1)}, \dots, j_{l,1}, j_{l,2}, \dots, j_{l,b(l)}). \end{aligned}$$

These are what we called the *shape of p*. Using these data, we define a “diagram labeling” map

$$\begin{aligned} f_p &: H_p(U_1, \dots, U_m; V_1, \dots, V_n) \\ &\longrightarrow \text{Hom}_{\mathcal{S}_C}(\langle U_1 \rangle_t \otimes \dots \otimes \langle U_m \rangle_t, \langle V_1 \rangle_t \otimes \dots \otimes \langle V_n \rangle_t) \end{aligned}$$

for each $p \in P(m, n)$ as follows. Put

$$\tilde{U}_k := U_{i_{k,1}} \otimes U_{i_{k,2}} \otimes \dots \otimes U_{i_{k,a(k)}}, \quad \tilde{V}_k := V_{j_{k,1}} \otimes V_{j_{k,2}} \otimes \dots \otimes V_{j_{k,b(k)}}.$$

For $\varphi_k: \tilde{U}_k \rightarrow \tilde{V}_k$ ($k = 1, \dots, l$), the corresponding morphism $f_p(\varphi_1 \otimes \dots \otimes \varphi_l)$ is defined to be

$$f_p(\varphi_1 \otimes \dots \otimes \varphi_l) := (\tau_C^h)^{-1} \circ \Delta_C^p \circ (\langle \varphi_1 \rangle_t \otimes \dots \otimes \langle \varphi_l \rangle_t) \circ \mu_C^p \circ \tau_C^g$$

where τ_C^g and τ_C^h are braidings along g and h respectively and

$$\begin{aligned} \mu_C^p &: \langle U_{g^{-1}(1)} \rangle_t \otimes \dots \otimes \langle U_{g^{-1}(m)} \rangle_t \rightarrow \langle \tilde{U}_1 \rangle_t \otimes \dots \otimes \langle \tilde{U}_l \rangle_t \\ \Delta_C^p &: \langle \tilde{V}_1 \rangle_t \otimes \dots \otimes \langle \tilde{V}_l \rangle_t \rightarrow \langle V_{h^{-1}(1)} \rangle_t \otimes \dots \otimes \langle V_{h^{-1}(n)} \rangle_t \end{aligned}$$

are suitable composites of μ_C, ι_C and Δ_C, ϵ_C respectively (this notion is well-defined since μ_C is associative and Δ_C is coassociative; see Proposition 4.26). So the morphism in Example 4.23 is written as $f_p(\varphi \otimes \psi \otimes \xi)$ if we choose a suitable shape of p . It is easy to check that this map also satisfies unitriangularity

$$f_p(\Phi) = \langle \Phi \rangle_t + \sum_{q \lesssim p} \langle \Theta_q \rangle_t. \quad (\Theta_q \in H_q(U_1, \dots, U_m; V_1, \dots, V_n)).$$

Thus by the induction on the partial order of the partitions, we have another isomorphism

$$\begin{aligned} &\text{Hom}_{\mathcal{S}_C}(\langle U_1 \rangle_t \otimes \dots \otimes \langle U_m \rangle_t, \langle V_1 \rangle_t \otimes \dots \otimes \langle V_n \rangle_t) \\ &\simeq \bigoplus_{p \in P(m,n)} f_p(H_p(U_1, \dots, U_m; V_1, \dots, V_n)). \end{aligned}$$

Notice that this isomorphism depends on the shapes of the partitions we have chosen.

We say that a diagram is of *standard form* if it represents a composite

$$(\tau_C^h)^{-1} \circ \Delta_C^p \circ (\langle \varphi_1 \rangle_t \otimes \cdots \otimes \langle \varphi_l \rangle_t) \circ \mu_C^p \circ \tau_C^g$$

for some $p \in P(m, n)$. Of course this notion also depends on the shapes we have chosen. Bring these arguments all together, we have the next proposition.

Proposition 4.24. *Every morphism $\langle U_1 \rangle_t \otimes \cdots \otimes \langle U_m \rangle_t \rightarrow \langle V_1 \rangle_t \otimes \cdots \otimes \langle V_n \rangle_t$ can be represented by a linear combination of diagrams of standard form. In such a representation, the corresponding component of $H_p(U_1, \dots, U_m; V_1, \dots, V_n)$ at each $p \in P(m, n)$ is uniquely determined.*

Remark 4.25. Several known algebras are appeared as the endomorphism ring of an object of the form $\langle U \rangle_t^{\otimes m} \in \mathcal{S}_t(\mathcal{C})$. For Deligne’s case $\mathcal{C} = \mathcal{R}ep(k)$, $End_{\mathcal{S}_t(\mathcal{C})}(\langle \mathbb{1}_k \rangle_t^{\otimes m})$ is the *partition algebra* introduced by Jones [9] and Martin [15]. More generally, fix $r \in \mathbb{N}$ and let $\mathcal{C} := \mathcal{R}ep(k)^{\mathbb{Z}/r\mathbb{Z}}$ the category of $(\mathbb{Z}/r\mathbb{Z})$ -graded k -modules (Deligne’s case is when $r = 1$). Let $U = \mathbb{1}_k[-1]$ which has a component $\mathbb{1}_k$ at degree 1, so

$$Hom_{\mathcal{C}}(U^{\otimes m}, U^{\otimes n}) \simeq \begin{cases} k, & \text{if } m \equiv n \pmod{r}, \\ 0, & \text{otherwise.} \end{cases}$$

The endomorphism ring $End_{\mathcal{S}_t(\mathcal{C})}(\langle U \rangle_t^{\otimes m})$ is called the *r-modular party algebra* [12]. It is spanned by diagrams whose number of input legs and that of output legs are congruent modulo r at each its connected component.

Another example is Knop’s case, $\mathcal{C} = \mathcal{R}ep(k[G])$ for a finite group G . The endomorphism ring $End_{\mathcal{S}_t(\mathcal{C})}(\langle k[G] \rangle_t^{\otimes m})$ is the *G-colored partition algebra* of Bloss [2]. To represent morphisms he uses little different diagrams from ours but we can easily translate them into our form using the following morphisms: the right multiplication $k[G] \rightarrow k[G]$ by $g \in G$, the diagonal embedding $k[G] \rightarrow k[G] \otimes k[G]$ and projection $k[G] \otimes k[G] \rightarrow k[G]$. Note that in either case objects of the form $\langle U \rangle_t^{\otimes m}$ generate the whole pseudo-abelian category $\mathcal{S}_t(\mathcal{C})$.

4.6. Universality of $\mathcal{S}_t(\mathcal{C})$

The last proposition tells us that $\mathcal{S}_t(\mathcal{C})$ is generated by the morphisms $\langle \varphi \rangle_t, \mu_{\mathcal{C}}(U, V), \iota_{\mathcal{C}}, \Delta_{\mathcal{C}}(U, V)$ and $\epsilon_{\mathcal{C}}$ as pseudo-abelian k -braided tensor category. Next we study the relations between them. Note that functoriality of the braiding implies that any diagram can pass under and jump over a string (including the Reidemeister move of type III):

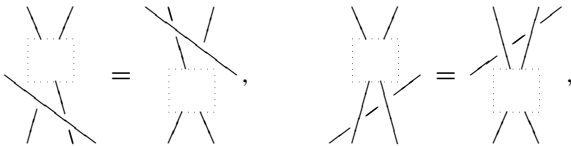

and of course we can also apply the Reidemeister move of type II:

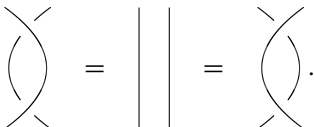

In addition, we can transform diagrams along the local moves listed in the next proposition. The proof is easy and straightforward. We prove later that these equations are enough to define $\mathcal{S}_t(\mathcal{C})$ by generators and relations.

Proposition 4.26. *In $\mathcal{S}_t(\mathcal{C})$, the morphisms $\langle \varphi \rangle_t$, $\mu_{\mathcal{C}}(U, V)$, $\iota_{\mathcal{C}}$, $\Delta_{\mathcal{C}}(U, V)$ and $\epsilon_{\mathcal{C}}$ satisfy the equations below.*

(1) $\langle \bullet \rangle_t : \mathcal{C} \rightarrow \mathcal{S}_t(\mathcal{C})$ is a k -linear functor:

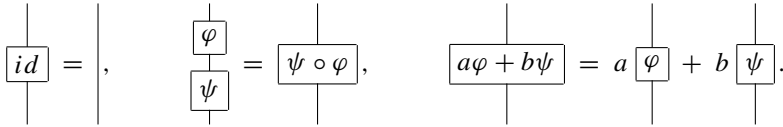

(2) $\mu_{\mathcal{C}} : \langle \bullet \rangle_t \otimes \langle \bullet \rangle_t \rightarrow \langle \bullet \otimes \bullet \rangle_t$ and $\Delta_{\mathcal{C}} : \langle \bullet \otimes \bullet \rangle_t \rightarrow \langle \bullet \rangle_t \otimes \langle \bullet \rangle_t$ are both k -linear transformations:

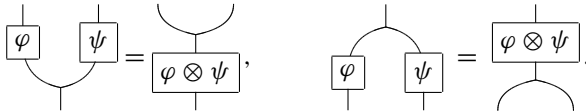

(3) Associativity and coassociativity:

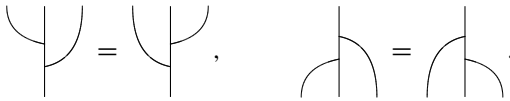

(4) Unitality and counitality:

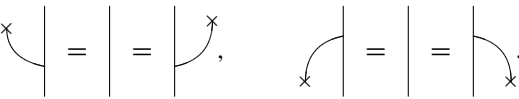

(5) $\mu_{\mathcal{C}}$ and $\Delta_{\mathcal{C}}$ commute with braidings:

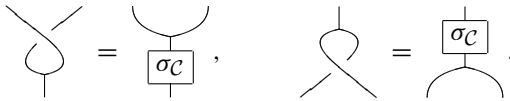

(6) Compatibility between $\mu_{\mathcal{C}}$ and $\Delta_{\mathcal{C}}$:



(7) $\mu_{\mathcal{C}}$ is a retraction and $\Delta_{\mathcal{C}}$ is a section:

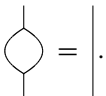

(8) Quadratic relation on braidings:



(9) The object $\langle \mathbb{1}_{\mathcal{C}} \rangle_t$ is of dimension t :

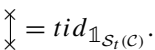

Using these equations, we can easily calculate composites of morphisms. Calculating tensor products is easier: it is nothing but arranging diagrams horizontally. Note that the rank t appears only when we remove isolated components from diagrams using the last equation (9).

Example 4.27.

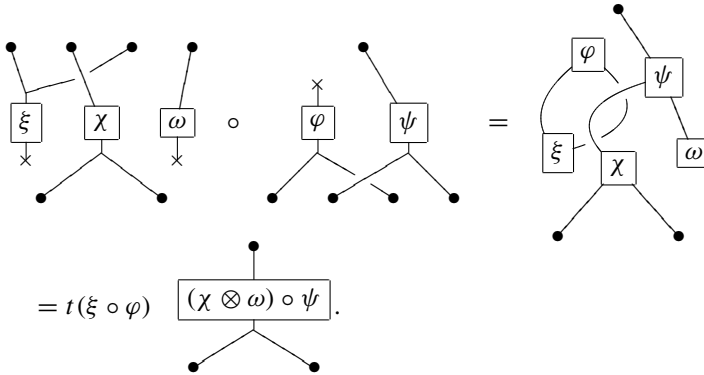

Notice that $(\bullet)_t: \mathcal{C} \rightarrow \mathcal{S}_t(\mathcal{C})$ is a k -linear functor between k -braided tensor categories but not a k -braided tensor functor. In fact, the conditions (1)–(5) is almost same as the definition of braided tensor functor but the only difference is that they do not require that $\mu_{\mathcal{C}}$ and $\Delta_{\mathcal{C}}$, $\iota_{\mathcal{C}}$ and $\epsilon_{\mathcal{C}}$ are inverse to each other. With this fact in mind, we define weaker notions of tensor functors and transformations.

Definition 4.28. Let \mathcal{C} and \mathcal{D} be k -tensor categories.

(1) A k -linear functor $F: \mathcal{C} \rightarrow \mathcal{D}$ is called a k -Frobenius functor if it is endowed with k -linear transformations

$$\begin{aligned} \mu_F: F(\bullet) \otimes F(\bullet) &\rightarrow F(\bullet \otimes \bullet), & \Delta_F: F(\bullet \otimes \bullet) &\rightarrow F(\bullet) \otimes F(\bullet), \\ \iota_F: \mathbb{1}_{\mathcal{D}} &\rightarrow F(\mathbb{1}_{\mathcal{C}}), & \epsilon_F: F(\mathbb{1}_{\mathcal{C}}) &\rightarrow \mathbb{1}_{\mathcal{D}} \end{aligned}$$

which are associative, unital, coassociative and counital (see Definition 2.12 (1)), and satisfies the compatibility conditions in Proposition 4.26 (6), i.e.

$$\begin{aligned} \Delta_F(U \otimes V, W) \circ \mu_F(U, V \otimes W) &= (\mu_F(U, V) \otimes id_W) \circ (id_U \otimes \Delta_F(V, W)), \\ \Delta_F(U, V \otimes W) \circ \mu_F(U \otimes V, W) &= (id_U \otimes \mu_F(V, W)) \circ (\Delta_F(U, V) \otimes id_W). \end{aligned}$$

The scalar $\epsilon_F \circ \iota_F \in \text{End}_{\mathcal{C}}(\mathbb{1}_{\mathcal{C}}) \simeq k$ is called the *dimension* of F and denoted by $\dim F$.

- (2) A k -Frobenius functor F is called *separable* if μ_F is a retraction and Δ_F is a section, i.e. $\mu_F(U, V) \circ \Delta_F(U, V) = id_{U \otimes V}$.
- (3) A k -Frobenius transformation $\eta: F \rightarrow G$ between two Frobenius functors is a k -linear transformation such that both the diagrams in Definition 2.12 (2) and their dual commute.

Definition 4.29. Let \mathcal{C} and \mathcal{D} be k -braided tensor categories.

- (1) A k -braided Frobenius functor $F: \mathcal{C} \rightarrow \mathcal{D}$ is a k -Frobenius functor such that μ_F and Δ_F commute with braidings. See Definition 2.13 (3).
- (2) A k -braided Frobenius functor F is called *quadratic* if it satisfies the quadratic relation

$$\begin{aligned} \sigma_{\mathcal{D}}(F(U), F(V)) - \sigma_{\mathcal{D}}^{-1}(F(U), F(V)) \\ = \Delta_F(V, U) \circ (\sigma_{\mathcal{C}}(U, V) - \sigma_{\mathcal{C}}^{-1}(U, V)) \circ \mu_F(U, V). \end{aligned}$$

- (3) A k -braided Frobenius transformation is just a k -Frobenius transformation between two k -braided Frobenius functors.

Thus Proposition 4.26 just says that $\langle \bullet \rangle_t : \mathcal{C} \rightarrow \mathcal{S}_t(\mathcal{C})$ is a k -braided Frobenius functor which is separable, quadratic, and of dimension t . Obviously an usual k -braided tensor functor is also but of dimension 1. Note that k -braided Frobenius functors are closed under composition and the properties listed above are preserved. In addition, $\dim(G \circ F) = \dim F \dim G$.

Remark 4.30. Frobenius functors, usually called Frobenius monoidal functors, were introduced and studied by Szlachányi [19,20], Day and Pastro [4]. Notice that McCurdy and Street [17] require a stronger relation

$$\sigma_{\mathcal{D}}(F(U), F(V)) = \Delta_F(V, U) \circ \sigma_{\mathcal{C}}(U, V) \circ \mu_F(U, V).$$

in their definition of the term “braided” on separable Frobenius functors than ours.

Now we state the universal property of $\mathcal{S}_t(\mathcal{C})$. That is, $\mathcal{S}_t(\mathcal{C})$ is the smallest category which has generators and satisfies relations as in Proposition 4.26. Let us denote by $\mathcal{H}om_k^{\mathbf{B}}(\mathcal{C}, \mathcal{D})$ (resp. $\mathcal{H}om_k^{\mathbf{BF}}(\mathcal{C}, \mathcal{D})$) the category of k -braided tensor (resp. Frobenius) functors and transformations.

Theorem 4.31. *Let \mathcal{C}, \mathcal{D} be k -braided tensor categories and assume that \mathcal{D} is pseudo-abelian.*

(1) *The natural functor*

$$\mathcal{H}om_k^{\mathbf{B}}(\mathcal{S}_t(\mathcal{C}), \mathcal{D}) \xrightarrow{\circ \langle \bullet \rangle_t} \mathcal{H}om_k^{\mathbf{BF}}(\mathcal{C}, \mathcal{D})$$

is fully faithful.

(2) *For $F \in \mathcal{H}om_k^{\mathbf{BF}}(\mathcal{C}, \mathcal{D})$, there exists $\tilde{F} \in \mathcal{H}om_k^{\mathbf{B}}(\mathcal{S}_t(\mathcal{C}), \mathcal{D})$ such that $F \simeq \tilde{F} \circ \langle \bullet \rangle_t$ as k -braided Frobenius functors if and only if F is separable, quadratic, and of dimension t .*

Proof. (1) Let $\tilde{F}, \tilde{G} : \mathcal{S}_t(\mathcal{C}) \rightarrow \mathcal{D}$ be k -braided tensor functors and put $F := \tilde{F} \circ \langle \bullet \rangle_t, G := \tilde{G} \circ \langle \bullet \rangle_t$. We have to show that the map between the sets of transformations

$$\begin{aligned} Hom_{\mathcal{H}om_k^{\mathbf{B}}(\mathcal{S}_t(\mathcal{C}), \mathcal{D})}(\tilde{F}, \tilde{G}) &\rightarrow Hom_{\mathcal{H}om_k^{\mathbf{BF}}(\mathcal{C}, \mathcal{D})}(F, G) \\ \tilde{\eta} &\mapsto \eta \end{aligned}$$

defined by $\eta(U) = \tilde{\eta}(\langle U \rangle_t)$ is bijective.

By the definition of k -tensor transformation, the map $\tilde{\eta}(\langle U_1 \rangle_t \otimes \cdots \otimes \langle U_m \rangle_t)$ is determined by each $\tilde{\eta}(\langle U_i \rangle_t) = \eta(U_i)$. Thus this map is injective. Conversely, for each k -braided Frobenius transformation $\eta : F \rightarrow G$, we can define $\tilde{\eta} : \tilde{F} \rightarrow \tilde{G}$ at each objects in $\mathcal{S}_t(\mathcal{C})$ as above. We can show easily that $\tilde{\eta}$ commute with all the morphisms in $\mathcal{S}_t(\mathcal{C})$; so $\tilde{\eta}$ is actually a transformation whose restriction is equal to η . Thus this map is also surjective.

(2) The “only if” part is obvious, so we prove the “if” part. Let us take a k -braided Frobenius functor $F : \mathcal{C} \rightarrow \mathcal{D}$ which is separable, quadratic and of dimension t . First we define \tilde{F} for objects $\langle U_1 \rangle_t \otimes \cdots \otimes \langle U_m \rangle_t$ by

$$\tilde{F}(\langle U_1 \rangle_t \otimes \cdots \otimes \langle U_m \rangle_t) := F(U_1) \otimes \cdots \otimes F(U_m).$$

The map for morphisms is determined by $\tilde{F}(\mu_{\mathcal{C}}) := \mu_F, \tilde{F}(\iota_{\mathcal{C}}) := \iota_F$ etc.; since all morphisms in $\mathcal{S}_t(\mathcal{C})$ are generated by them. By taking its pseudo-abelian envelope, we can extend its domain to the whole objects in $\mathcal{S}_t(\mathcal{C})$.

To prove its well-definedness, we have to show that a linear combination of diagrams which represents a zero morphism in $\mathcal{S}_t(\mathcal{C})$ is also zero in \mathcal{D} . Here we also use diagrams to denote morphisms in \mathcal{D} which are came from \mathcal{C} via F . By Proposition 4.24 it suffices to show that every

diagram can be transformed into a linear combination of diagrams of standard form using the relations listed in Proposition 4.26 only. First we state the next lemma.

Lemma 4.32. *If two strings in left-hand sides below are connected,*

$$\begin{array}{c} \diagup \\ \diagdown \\ \diagdown \\ \diagup \end{array} = \boxed{\sigma_C}, \quad \begin{array}{c} \diagdown \\ \diagup \\ \diagup \\ \diagdown \end{array} = \boxed{\sigma_C^{-1}}.$$

Proof. It suffices to prove the first equation. By the assumption we can find a loop connecting the two strings. The shape of the loop looks like either of the diagrams below depending on whether the loop contains the other side of the crossing or not:



We prove the equation by the induction on sizes of loops. So we may assume that the loop has no short circuits and other self-crossings. To prove the equation we can reverse crossings in the loop freely since the right-hand side of the relation (8) makes smaller loops. So we can remove all unconnected strings from the diagram. In addition, the crossing in the loop of second type above can be moved to the outside of the loop since the strings in the other side of the crossing are not connected to the loop:

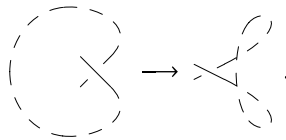

Thus we may assume that the loop is of first type.

If there is a string in the loop, by the assumptions the string is connected to the loop at only one point. If this string has a crossing with the loop, by the hypothesis of the induction we can apply the lemma to this crossing and we get a smaller loop. Otherwise we can flip it to the outside using (5):

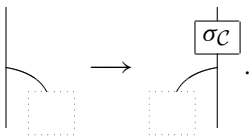

Thus we may assume that there is no strings in the loop. We can remove extra parts on the loop by using (2), (3) and (6). So it suffices to prove the equation in two special cases below:

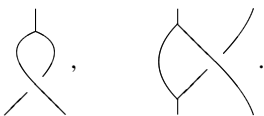

The proof is easy and we left it to the reader. \square

Let us continue the proof of the theorem. First take an arbitrary connected diagram. Using this lemma, we can remove all crossings from the diagram and we get a planar diagram. If the diagram has extra ι_C 's and ϵ_C 's we can put them together to other strings using the lemma and the relation (4). By removing all bubbles using (6), we get a tree diagram which has no extra endpoints. If the diagram represents a morphism $\mathbb{1}_{S_t(\mathcal{C})} \rightarrow \mathbb{1}_{S_t(\mathcal{C})}$, we can transform it into a scalar by (9). Otherwise we can move all μ_C 's to the top of the diagram and Δ_C 's to the bottom; then we obtain a diagram of standard form.

Next we prove this for any diagram which has more than two connected components by the induction on the number of them. For such a diagram, first we reverse some crossings using (8) so that the connected components are totally ordered from the back of the paper to the front. Because the number of the connected components of right-hand side of (8) is less than that of left-hand side, we can apply the hypothesis of the induction to the difference between them. Then we can transform each connected component to standard form in the manner described above. Reversing some crossings again, we get a diagram of standard form. \square

Remark 4.33. Let \mathcal{C} be a k -tensor category and consider the subcategory $\mathcal{TL}_t(\mathcal{C})$ of $S_t(\mathcal{C})$ whose objects are generated by $\langle U_1 \rangle_t \otimes \cdots \otimes \langle U_m \rangle_t$ for all $U_1, \dots, U_m \in \mathcal{C}$ and morphisms between them are k -linear combinations of “non-crossing” diagrams, i.e. composites of $\langle \varphi \rangle_t$, μ_C , ι_C , Δ_C and ϵ_C . This k -tensor category is a “ \mathcal{C} -colored” version of so-called Temperley–Lieb category [7] and satisfies the same universality as in Theorem 4.31 with respect to separable k -Frobenius functors of dimension t . The important difference between S_t and \mathcal{TL}_t is that we can naturally apply \mathcal{TL}_t to any k -linear bicategories, in other words, k -tensor categories with several 0-cells.

5. Classification of indecomposable objects

In this section we assume that k is a field of characteristic zero. The purpose of this section is to explain the structure of our category $S_t(\mathcal{C})$.

5.1. For Deligne’s category

Let us denote Deligne’s category $S_t(\mathcal{R}ep(k))$ by \mathcal{D}_t . We review here the result of Comes and Ostrik [3] which describes the complete classification of indecomposable objects in \mathcal{D}_t .

For $m \in \mathbb{N}$, we use the same symbol m to denote the family of objects $(\mathbb{1}_k)_{i=1}^m$ which contains the trivial representation $\mathbb{1}_k$ by multiplicity m so that we can write an object in \mathcal{D}_t as $\langle m \rangle_t$. Let us denote by $E_{t,m}$ the k -algebra $End_{\mathcal{D}_t}(\langle m \rangle_t)$. It is the direct sum of $\langle\langle H_r(m; m) \rangle\rangle_t$ for all recollements $r \in R(m, m)$ and each $H_r(m; m)$ is one-dimensional.

Lemma 5.1. *Let $m \in \mathbb{N}$ and put $A := \langle\langle H^m(m; m) \rangle\rangle_t$, $I := \langle\langle H^{>m}(m; m) \rangle\rangle_t$. Then*

- (1) $E_{t,m} = A \oplus I$ as a k -module,
- (2) A is a k -subalgebra of $E_{t,m}$ isomorphic to $k[\mathfrak{S}_m]$,
- (3) I is a two-sided ideal of $E_{t,m}$.

Thus $E_{t,m}/I \simeq k[\mathfrak{S}_m]$ as a k -algebra.

Proof. (1) and (2) are obvious. (3) follows from Corollary 4.20. \square

We recall here some facts about representations of symmetric groups in characteristic zero. For details, see e.g. [8]. A Young diagram $\lambda = (\lambda_1, \lambda_2, \dots)$ is a non-increasing sequence of natural numbers such that all but finitely many entries are zero. We call $|\lambda| := \sum_i \lambda_i$ the size

of λ and denote by $\emptyset = (0, 0, \dots)$ the unique Young diagram of size zero. We denote by \mathcal{P} the set of all Young diagrams and by \mathcal{P}_m the set of those with size m . There is a one to one correspondence

$$\mathcal{P}_m \xleftrightarrow{1:1} \{\text{irreducible representations of } \mathfrak{S}_m\}$$

and we denote by S_λ the irreducible representation of \mathfrak{S}_m corresponding to $\lambda \in \mathcal{P}_m$.

For each $\lambda \in \mathcal{P}_m$, the $k[\mathfrak{S}_m]$ -module S_λ can be regarded as an $E_{t,m}$ -module via the map $E_{t,m} \rightarrow k[\mathfrak{S}_m]$. Its projective cover $P(S_\lambda)$ is isomorphic to $E_{t,m}$ -module of the form $E_{t,m}e_{t,\lambda}$ where $e_{t,\lambda} \in E_{t,m}$ is some primitive idempotent. Then its image $L_{t,\lambda} := e_{t,\lambda}\langle m \rangle_t \in \mathcal{D}_t$ is indecomposable and well-defined up to isomorphism.

Remark 5.2. In [3], $L_{t,\lambda}$ is defined as a direct summand of $\langle 1 \rangle_t^{\otimes m}$, not $\langle m \rangle_t$.

For a Krull–Schmidt k -linear category \mathcal{C} , we denote by $I(\mathcal{C})$ the set of isomorphism classes of indecomposable objects in \mathcal{C} . For $U, V \in I(\mathcal{C})$, we say U and V are in the same block if there exists a chain of indecomposable objects $U = U_0, U_1, \dots, U_m = V \in I(\mathcal{C})$ such that either $\text{Hom}_{\mathcal{C}}(U_{i-1}, U_i)$ or $\text{Hom}_{\mathcal{C}}(U_i, U_{i-1})$ is non-zero for each $i = 1, \dots, m$. We also use the term block to refer each pseudo-abelian full subcategory of \mathcal{C} generated by all indecomposable objects in a same block. A block is called trivial if it is equivalent to $\text{Rep}(k)$. Note that such a category is equivalent to the direct sum of all its blocks.

Theorem 5.3 (Deligne [5], Comes–Ostrik [3]).

- (1) $\lambda \mapsto L_{t,\lambda}$ gives a bijection $\mathcal{P} \xrightarrow{1:1} I(\mathcal{D}_t)$.
- (2) If $t \notin \mathbb{N}$ then all blocks in \mathcal{D}_t are trivial.
- (3) For $d \in \mathbb{N}$, non-trivial blocks in \mathcal{D}_d are parameterized by Young diagrams of size d . For $\lambda \in \mathcal{P}_d$, let us define $\lambda^{(j)} = (\lambda_1^{(j)}, \lambda_2^{(j)}, \dots) \in \mathcal{P}$ by

$$\lambda_i^{(j)} = \begin{cases} \lambda_i + 1, & \text{if } 1 \leq i \leq j, \\ \lambda_{i+1}, & \text{otherwise.} \end{cases}$$

Then $L_{d,\lambda^{(0)}}, L_{d,\lambda^{(1)}}, \dots$ generate a block in \mathcal{D}_d and all non-trivial blocks are obtained by this construction. Morphisms between them are spanned by

$$\begin{array}{ccccccc} \begin{array}{c} \text{id} \\ \curvearrowright \\ L_{d,\lambda^{(0)}} \end{array} & \begin{array}{c} \xrightarrow{\alpha_0} \\ \xleftarrow{\beta_0} \end{array} & \begin{array}{c} \text{id} \\ \curvearrowright \\ L_{d,\lambda^{(1)}} \\ \curvearrowleft \\ \gamma_1 \end{array} & \begin{array}{c} \xrightarrow{\alpha_1} \\ \xleftarrow{\beta_1} \end{array} & \begin{array}{c} \text{id} \\ \curvearrowright \\ L_{d,\lambda^{(2)}} \\ \curvearrowleft \\ \gamma_2 \end{array} & \begin{array}{c} \xrightarrow{\alpha_2} \\ \xleftarrow{\beta_2} \end{array} & \dots \end{array}$$

where $\beta_n \alpha_n = \alpha_{n-1} \beta_{n-1} = \gamma_n$ for $n \geq 1$ and other non-trivial composites are zero. The canonical functor $\mathcal{D}_d \rightarrow \text{Rep}(k[\mathfrak{S}_d])$ sends $L_{d,\lambda^{(0)}}$ to S_λ for each $\lambda \in \mathcal{P}_m$ and the other indecomposable objects to the zero object.

5.2. Direct sum of categories

Let \mathcal{C} be a pseudo-abelian k -linear category with unit. Assume that \mathcal{C} admits a direct sum decomposition $\mathcal{C} \simeq \bigoplus_{x \in X} \mathcal{C}_x$ with index set X (e.g. by blocks). There is a unique \mathcal{C}_x which contains the unit object $\mathbb{1}_{\mathcal{C}}$ so let us denote its index by $x = 0$ and put $X' := X \setminus \{0\}$.

Recall that we have two kinds of $*$ -product

$$\begin{aligned} \mathcal{S}_{t_1}(\mathcal{C}) \overline{\boxtimes} \mathcal{W}_{d_2}(\mathcal{C}) &\rightarrow \mathcal{S}_{t_1+d_2}(\mathcal{C}), & \mathcal{W}_{d_1}(\mathcal{C}) \overline{\boxtimes} \mathcal{W}_{d_2}(\mathcal{C}) &\rightarrow \mathcal{W}_{d_1+d_2}(\mathcal{C}) \\ \langle U_I \rangle_{t_1} * [W_K]_{d_2} &:= \langle U_I \sqcup W_K \rangle_{t_1+d_2}, & [V_J]_{d_1} * [W_K]_{d_2} &:= [V_J \sqcup W_K]_{d_1+d_2} \end{aligned}$$

defined for objects which satisfy $\#J = d_1$ and $\#K = d_2$. By definition, as pseudo-abelian k -linear category, $\mathcal{S}_t(\mathcal{C})$ is generated by objects of the form $\langle U_I \rangle_t$ where for each $i \in I$ its component U_i is in some \mathcal{C}_{x_i} . For such a family we write $I_x := \{i \in I \mid x_i = x\}$ and denote by U_{I_x} the subfamily of U_I indexed by I_x . Then we can write

$$\langle U_I \rangle_t \simeq \langle U_{I_0} \rangle_{t_0} * \prod_{x \in X'} [U_{I_x}]_{d_x}$$

using the $*$ -product. Here $d_x := \#I_x$, $t_0 := t - \sum_{x \in X'} d_x$ and \prod denotes the $*$ -product of finite terms for $x \in X'$ with $I_x \neq \emptyset$.

Let U_I and V_J be families of objects of such form. By the assumptions $\text{Hom}_{\mathcal{C}}(\mathbb{1}_{\mathcal{C}}, W) \simeq 0 \simeq \text{Hom}_{\mathcal{C}}(W, \mathbb{1}_{\mathcal{C}})$ for all $W \in \mathcal{C}_x$ when $x \neq 0$. So in the direct sum

$$\text{Hom}_{\mathcal{S}_t(\mathcal{C})}(\langle U_I \rangle_t, \langle V_J \rangle_t) \simeq \bigoplus_{r \in R(I, J)} H_r(U_I; V_J)$$

we only need recollements $r \in R(I, J)$ all whose components $(i, j) \in r$ satisfy one of the conditions below:

$$\begin{cases} i, j \neq \emptyset & \text{and } x_i = x_j, \\ i = \emptyset & \text{and } x_j = 0, \\ j = \emptyset & \text{and } x_i = 0. \end{cases}$$

Thus $\text{Hom}_{\mathcal{S}_t(\mathcal{C})}(\langle U_I \rangle_t, \langle V_J \rangle_t) = 0$ unless $\#I_x = \#J_x$ for all $x \in X'$. Otherwise

$$\text{Hom}_{\mathcal{S}_t(\mathcal{C})}(\langle U_I \rangle_t, \langle V_J \rangle_t) \simeq H(U_{I_0}; V_{J_0}) \otimes \bigotimes_{x \in X'} H'(U_{I_x}; V_{J_x})$$

where for each $U_{I'} = (U_1, \dots, U_d)$ and $V_{J'} = (V_1, \dots, V_d)$,

$$H'(U_{I'}; V_{J'}) := \bigoplus_{g \in \mathfrak{S}_d} \text{Hom}_{\mathcal{C}}(U_1, V_{g(1)}) \otimes \dots \otimes \text{Hom}_{\mathcal{C}}(U_d, V_{g(d)})$$

which is isomorphic to $\text{Hom}_{\mathcal{W}_d(\mathcal{C})}([U_{I'}]_d, [V_{J'}]_d)$. The same arguments also hold for $\mathcal{W}_d(\mathcal{C})$ and we have following equivalences of k -linear category.

Proposition 5.4. *Let \mathcal{C} be a k -linear category which admits a decomposition $\mathcal{C} \simeq \bigoplus_{x \in X} \mathcal{C}_x$. Then the $*$ -product induces a category equivalence*

$$\bigoplus_{\substack{d_x \in \mathbb{N} \\ d = \sum_{x \in X} d_x}} \left(\overline{\boxtimes}_{x \in X} \mathcal{W}_{d_x}(\mathcal{C}_x) \right) \xrightarrow{\sim} \mathcal{W}_d(\mathcal{C}).$$

In addition, assume that \mathcal{C} has the unit $\mathbb{1}_{\mathcal{C}} \in \mathcal{C}_0$. Put $X' := X \setminus \{0\}$. Then we have another equivalence

$$\bigoplus_{\substack{t_0 \in k, d_x \in \mathbb{N} \\ t = t_0 + \sum_{x \in X'} d_x}} \left(\mathcal{S}_{t_0}(\mathcal{C}_0) \overline{\boxtimes}_{x \in X'} \overline{\boxtimes}_{x \in X'} \mathcal{W}_{d_x}(\mathcal{C}_x) \right) \xrightarrow{\sim} \mathcal{S}_t(\mathcal{C})$$

also induced by $*$ -product.

For example, let us consider the case when \mathcal{C} is a hom-finite pseudo-abelian k -linear category whose unit object $\mathbb{1}_{\mathcal{C}} \in \mathcal{C}$ has no extension, i.e. is in a trivial block $\mathcal{R}ep(k) \subset \mathcal{C}$. So there is a pseudo-abelian full subcategory $\mathcal{C}' \subset \mathcal{C}$ such that $\mathcal{C} \simeq \mathcal{R}ep(k) \oplus \mathcal{C}'$. By applying the proposition, we have

$$\mathcal{S}_t(\mathcal{C}) \simeq \bigoplus_{d \in \mathbb{N}} \left(\mathcal{D}_{t-d} \boxtimes \overline{\mathcal{W}}_d(\mathcal{C}') \right).$$

Let us take indecomposable objects $L \in \mathcal{D}_{t-d}$ and $U \in \mathcal{W}_d(\mathcal{C}')$ respectively and consider $L * U \in \mathcal{S}_t(\mathcal{C})$. By [Theorem 5.3](#), $End_{\mathcal{D}_{t-d}}(L)$ is isomorphic to either k or $k[\gamma]/(\gamma^2)$. Thus its endomorphism ring

$$End_{\mathcal{S}_t(\mathcal{C})}(L * U) \simeq End_{\mathcal{D}_{t-d}}(L) \otimes End_{\mathcal{W}_d(\mathcal{C}')} (U)$$

is still local and $L * U$ is also an indecomposable object. By [Theorem 2.6](#), all indecomposable objects in $\mathcal{S}_t(\mathcal{C})$ is of this form and each block in $\mathcal{S}_t(\mathcal{C})$ is therefore equivalent to a tensor product of two blocks in \mathcal{D}_{t-d} and $\mathcal{W}_d(\mathcal{C}')$ respectively.

5.3. For semisimple category

A hom-finite pseudo-abelian k -linear category \mathcal{C} is called *semisimple* if every non-zero morphism between indecomposable objects in \mathcal{C} is an isomorphism, or equivalently, if the endomorphism ring of each object in \mathcal{C} is a finite dimensional semisimple k -algebra. We state a simple criterion for semisimplicity of $\mathcal{S}_t(\mathcal{C})$.

Proposition 5.5. *Let \mathcal{C} be a hom-finite pseudo-abelian k -linear category with unit. Then $\mathcal{S}_t(\mathcal{C})$ is semisimple if and only if $t \notin \mathbb{N}$ and \mathcal{C} is semisimple.*

Proof. If $t \in \mathbb{N}$, $\mathcal{S}_t(\mathcal{C})$ contains a non-semisimple full subcategory \mathcal{D}_t so $\mathcal{S}_t(\mathcal{C})$ itself is not semisimple. If \mathcal{C} is not semisimple, there are indecomposable objects $U_1, U_2 \in I(\mathcal{C})$ and non-zero morphism $\varphi: U_1 \rightarrow U_2$ which is not invertible. For $i = 1, 2$, we have a k -algebra homomorphism $End_{\mathcal{S}_t(\mathcal{C})}(\langle U_i \rangle_t) \rightarrow End_{\mathcal{C}}(U_i)$. By taking its projective cover, we obtain an idempotent $e_i \in End_{\mathcal{S}_t(\mathcal{C})}(\langle U_i \rangle_t)$ such that its image $e_i \langle U_i \rangle_t$ is indecomposable and $e_2 \langle \varphi \rangle_t e_1: e_1 \langle U_1 \rangle_t \rightarrow e_2 \langle U_2 \rangle_t$ is not zero or invertible. Thus $\mathcal{S}_t(\mathcal{C})$ is not semisimple either in this case.

Conversely assume that $t \notin \mathbb{N}$ and \mathcal{C} is semisimple. Then $\mathcal{C} \simeq \mathcal{R}ep(k) \oplus \mathcal{C}'$ for some semisimple full subcategory $\mathcal{C}' \subset \mathcal{C}$. Since semisimplicity of k -algebra is preserved under tensor products and wreath products in characteristic zero, we have that $\mathcal{S}_t(\mathcal{C})$ is also semisimple by [Proposition 5.4](#) and [Theorem 5.3](#) (2). \square

Now assume that \mathcal{C} is semisimple and all blocks are trivial, i.e., every indecomposable object $U \in I(\mathcal{C})$ satisfies $End_{\mathcal{C}}(U) \simeq k$. We give a complete description of the k -linear category $\mathcal{S}_t(\mathcal{C})$ for this case parallel to [Theorem 5.3](#).

Let $\mathcal{P}^{\mathcal{C}}$ be the set

$$\mathcal{P}^{\mathcal{C}} := \{ \lambda: I(\mathcal{C}) \rightarrow \mathcal{P} \mid \lambda(U) = \emptyset \text{ for all but finitely many } U \}.$$

For each $\lambda \in \mathcal{P}^{\mathcal{C}}$, we write $|\lambda| := \sum_U |\lambda(U)|$ and $|\lambda'| := \sum_{U \neq \mathbb{1}_{\mathcal{C}}} |\lambda(U)|$. For each $d \in \mathbb{N}$, put $\mathcal{P}_d^{\mathcal{C}} := \{ \lambda \in \mathcal{P}^{\mathcal{C}} \mid |\lambda| = d \}$.

Take an idempotent $f_{\lambda} \in k[\mathfrak{S}_d]$ for each $\lambda \in \mathcal{P}_d^{\mathcal{C}}$ which satisfies $S_{\lambda} \simeq k[\mathfrak{S}_d] f_{\lambda}$. For $U \in I(\mathcal{C})$, since $End_{\mathcal{W}_d(\mathcal{C})}(U^{*d}) \simeq k[\mathfrak{S}_d]$, we can define the object $U^{\boxtimes \lambda} \in I(\mathcal{W}_d(\mathcal{C}))$ by $U^{\boxtimes \lambda} := f_{\lambda} U^{*d}$. Let

$$\bar{L}_{t,\lambda} := L_{t-|\lambda|,\lambda(\mathbb{1}_C)} * \prod_{U \neq \mathbb{1}_C} U^{\boxtimes \lambda(U)} \in \mathcal{S}_t(\mathcal{C})$$

for $\lambda \in \mathcal{P}^C$ and

$$\bar{S}_\lambda := S_{\lambda(\mathbb{1}_C)} * \prod_{U \neq \mathbb{1}_C} U^{\boxtimes \lambda(U)} \in \mathcal{W}_d(\mathcal{C})$$

for $\lambda \in \mathcal{P}_d^C$. Applying Proposition 5.4 to the block decomposition of \mathcal{C} , we have $\bar{L}_{t,\lambda}$ (resp. \bar{S}_λ) is indecomposable and all indecomposable objects in $\mathcal{S}_t(\mathcal{C})$ (resp. $\mathcal{W}_d(\mathcal{C})$) are of such form. We can now extend Theorem 5.3, the result of Comes and Ostrik.

- Theorem 5.6.** (1) $\lambda \mapsto \bar{L}_{t,\lambda}$ gives a bijection $\mathcal{P}^C \xrightarrow{1:1} I(\mathcal{S}_t(\mathcal{C}))$.
 (2) If $t \notin \mathbb{N}$ then all blocks in $\mathcal{S}_t(\mathcal{C})$ are trivial.
 (3) For $d \in \mathbb{N}$, non-trivial blocks in $\mathcal{S}_d(\mathcal{C})$ are parameterize by \mathcal{P}_d^C . The non-trivial block corresponding to $\lambda \in \mathcal{P}_d^C$ is generated by indecomposable objects $\bar{L}_{d,\lambda^{(0)}}, \bar{L}_{d,\lambda^{(1)}}, \dots$. Here $\lambda^{(0)}, \lambda^{(1)}, \dots \in \mathcal{P}^C$ is given by

$$\lambda^{(j)}(U) := \begin{cases} \lambda(\mathbb{1}_C)^{(j)}, & \text{if } U = \mathbb{1}_C, \\ \lambda(U), & \text{otherwise.} \end{cases}$$

This block is equivalent to a non-trivial block in \mathcal{D}_d which is described in Theorem 5.3(3). The canonical functor $\mathcal{S}_d(\mathcal{C}) \rightarrow \mathcal{W}_d(\mathcal{C})$ sends $\bar{L}_{d,\lambda^{(0)}}$ to \bar{S}_λ and the other indecomposable objects to the zero object.

Acknowledgments

I would like to thank Hisayosi Matumoto who taught me about representation theory from the basics for a long time. I am also grateful to my colleagues, especially to Hideaki Hosaka and Hironori Kitagawa for many useful suggestions.

Appendix. Tensor categories with additional structures

There are various kinds of additional structures on tensor categories which are introduced in many literature (e.g. see [18]) and used in various fields of mathematics, physics and even computer science. It is straightforward to show that these structures are compatible with standard operations on categories: taking an envelope, a tensor product or a category of invariants under group action. In this appendix we introduce that our 2-functor \mathcal{S}_t also respects many of them.

A.1. Duals

Definition A.1. Let \mathcal{C} be a tensor category. A left dual of an object $U \in \mathcal{C}$ is an object $U^* \in \mathcal{C}$ along with morphisms $ev_U : U^* \otimes U \rightarrow \mathbb{1}_C$ and $coev_U : \mathbb{1}_C \rightarrow U \otimes U^*$ such that the composites

$$\begin{array}{c} U \xrightarrow{coev_U \otimes id_U} U \otimes U^* \otimes U \xrightarrow{id_U \otimes ev_U} U, \\ U^* \xrightarrow{id_{U^*} \otimes coev_U} U^* \otimes U \otimes U^* \xrightarrow{ev_U \otimes id_{U^*}} U^* \end{array}$$

are both identities. Such triple $(U^*, ev_U, coev_U)$ is unique up to unique isomorphism when it exists. For a morphism $\varphi : U \rightarrow V$ between objects which have left duals, its left dual

$\varphi^* : V^* \rightarrow U^*$ is defined as the composite

$$V^* \xrightarrow{id_{V^*} \otimes coev_U} V^* \otimes U \otimes U^* \xrightarrow{id_{V^*} \otimes \varphi \otimes id_{U^*}} V^* \otimes V \otimes U^* \xrightarrow{ev_V \otimes id_{U^*}} U^*.$$

The *right dual* *U is defined similarly with the reversed tensor product so ${}^*(U^*) \simeq U \simeq ({}^*U)^*$. The tensor category \mathcal{C} is called *rigid* (or *autonomous*) if every its object has both left and right duals.

By definition $\mathbb{1}_{\mathcal{C}}^* \simeq \mathbb{1}_{\mathcal{C}}$ and there is a functorial isomorphism $(U \otimes V)^* \simeq V^* \otimes U^*$ when they exist. In addition, if $\sigma_{\mathcal{C}}$ is a braiding in \mathcal{C} , $\sigma_{\mathcal{C}}(U, V)^* = \sigma_{\mathcal{C}}(U^*, V^*)$ via the isomorphism. So a rigid (braided) tensor category \mathcal{C} is (braided) tensor equivalent to its opposite category \mathcal{C}^{op} via the functor $U \mapsto U^*$ if we define the suitable structure on \mathcal{C}^{op} .

Note that the left dual U^* of U need not to be isomorphic to its right dual *U . In a rigid tensor category every tensor transformation $\bullet^* \rightarrow {}^*\bullet$ is automatically invertible and such a functorial isomorphism is called a *pivot*.

Example A.2. When A is a Hopf algebra over k , the k -tensor category $\mathcal{R}ep(A)$ is rigid. For $U \in \mathcal{R}ep(A)$, its left dual U^* and right dual *U are both defined as an A^{op} -module $Hom_k(U, k)$ and A acts on them via the antipode $\gamma_A : A \rightarrow A^{op}$ and its inverse γ_A^{-1} respectively. Note that $Mod(A)$ is not rigid since we cannot define a suitable map $\mathbb{1}_A \rightarrow U \otimes U^*$ for an arbitrary $U \in Mod(A)$.

If $U \in \mathcal{C}$ has a left dual U^* , $\langle U \rangle_t \in \mathcal{S}_t(\mathcal{C})$ also has a left dual $\langle U^* \rangle_t$. The equipped morphisms are the composites

$$\begin{aligned} \langle U^* \rangle_t \otimes \langle U \rangle_t &\xrightarrow{\mu_{\mathcal{C}}(U^*, U)} \langle U^* \otimes U \rangle_t \xrightarrow{\langle ev_U \rangle_t} \langle \mathbb{1}_{\mathcal{C}} \rangle_t \xrightarrow{\epsilon_{\mathcal{C}}} \mathbb{1}_{\mathcal{S}_t(\mathcal{C})}, \\ \mathbb{1}_{\mathcal{S}_t(\mathcal{C})} &\xrightarrow{\iota_{\mathcal{C}}} \langle \mathbb{1}_{\mathcal{C}} \rangle_t \xrightarrow{\langle coev_U \rangle_t} \langle U \otimes U^* \rangle_t \xrightarrow{\Delta_{\mathcal{C}}(U, U^*)} \langle U \rangle_t \otimes \langle U^* \rangle_t \end{aligned}$$

illustrated as

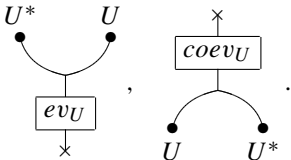

Conversely, suppose that $\langle U \rangle_t$ has a left dual $\langle U \rangle_t^*$. The equation $id_{\langle U \rangle_t^*} = (ev_{\langle U \rangle_t} \otimes id_{\langle U \rangle_t^*}) \circ (id_{\langle U \rangle_t^*} \otimes coev_{\langle U \rangle_t})$ implies that $id_{\langle U \rangle_t^*}$ factors through some $\langle V \rangle_t$ so $\langle U \rangle_t^*$ is isomorphic to the image of an idempotent $f : \langle V \rangle_t \rightarrow \langle V \rangle_t$. Now f can be decomposed as

$$f = \langle e \rangle_t + \sum_i \langle \varphi_i \rangle_t \otimes \langle \psi_i \rangle_t$$

by $e : V \rightarrow V$ and $\varphi_i : V \rightarrow \mathbb{1}_{\mathcal{C}}, \psi_i : \mathbb{1}_{\mathcal{C}} \rightarrow V$. Then e is also idempotent and its image eV is a left dual of U . The same holds for right duals and thus $\mathcal{S}_t(\mathcal{C})$ is rigid if and only if \mathcal{C} is rigid.

A.2. Traces

Definition A.3. A (right) trace on a k -tensor category \mathcal{C} is a family $\{Tr_X\}_{X \in \mathcal{C}}$ of k -linear transformations $Tr_X : Hom_{\mathcal{C}}(\bullet \otimes X, \bullet \otimes X) \rightarrow Hom_{\mathcal{C}}(\bullet, \bullet)$ which satisfies

- (1) $Tr_X(\varphi \circ (id_U \otimes \psi)) = Tr_Y((id_V \otimes \psi) \circ \varphi)$ for each $\varphi : U \otimes Y \rightarrow V \otimes X$ and $\psi : X \rightarrow Y$,

- (2) $\text{Tr}_X(\varphi \otimes \psi) = \varphi \otimes \text{Tr}_X(\psi)$,
- (3) $\text{Tr}_{\mathbb{1}_C}(\varphi) = \varphi$ and $\text{Tr}_{X \otimes Y}(\varphi) = \text{Tr}_X(\text{Tr}_Y(\varphi))$.

We remark that if the category is rigid there is a one to one correspondence between traces and pivots. For a given trace we can define a pivot $p_C(U) := \text{Tr}_U(U^* \otimes U \xrightarrow{ev_U} \mathbb{1}_C \xrightarrow{coev_{*U}} *U \otimes U)$. Conversely, each pivot $p_C: \bullet^* \rightarrow * \bullet$ induces a trace defined by

$$\text{Tr}_X(\varphi) := (U \xrightarrow{id_U \otimes coev_X} U \otimes X \otimes X^* \xrightarrow{\varphi \otimes p_C(X)} V \otimes X \otimes * X \xrightarrow{id_V \otimes ev_{*X}} V)$$

for $\varphi: U \otimes X \rightarrow V \otimes X$.

For each trace on C there is a unique trace on $S_t(C)$ which satisfies

$$\begin{aligned} &\langle \text{Tr}_X(\varphi) \rangle_t \\ &= \text{Tr}_{\langle X \rangle_t}(\langle U \rangle_t \otimes \langle X \rangle_t \xrightarrow{\mu_C(U, X)} \langle U \otimes X \rangle_t \xrightarrow{\langle \varphi \rangle_t} \langle V \otimes X \rangle_t \xrightarrow{\Delta_C(V, X)} \langle V \rangle_t \otimes \langle X \rangle_t) \end{aligned}$$

for every $\varphi: U \otimes X \rightarrow V \otimes X$. To construct this trace it suffices to define transformations $\text{Tr}_{\langle X \rangle_t}$ for each $X \in C$. First let $f \mapsto \bar{f}$ be an idempotent endomorphism on $\text{Hom}_{S_t(C)}(A \otimes \langle X \rangle_t, B \otimes \langle X \rangle_t)$ defined by

$$\begin{aligned} \bar{f} := & (A \otimes \langle X \rangle_t \xrightarrow{id_A \otimes \Delta_C(X, \mathbb{1}_C)} A \otimes \langle X \rangle_t \otimes \langle \mathbb{1}_C \rangle_t \xrightarrow{f \otimes id_{\langle \mathbb{1}_C \rangle_t}} B \otimes \langle X \rangle_t \otimes \langle \mathbb{1}_C \rangle_t \\ & \xrightarrow{id_B \otimes \mu_C(X, \mathbb{1}_C)} B \otimes \langle X \rangle_t). \end{aligned}$$

By the axioms of trace it must satisfy $\text{Tr}_{\langle X \rangle_t}(\bar{f}) = \text{Tr}_{\langle X \rangle_t}(f)$. Now let U_I and V_J be families of objects in C . The image of $\bar{\bullet}$ on $\text{Hom}_{S_t(C)}(\langle U_I \rangle_t \otimes \langle X \rangle_t, \langle V_J \rangle_t \otimes \langle X \rangle_t)$ is the direct sum

$$\bigoplus_{\substack{i \in I \cup \{\emptyset\} \\ j \in J \cup \{\emptyset\}}} \langle H(U_{I \setminus \{i\}}; V_{J \setminus \{j\}}) \otimes \text{Hom}_C(U_i \otimes X, V_j \otimes X) \rangle_t.$$

For $\Phi \in H_r(U_{I \setminus \{i\}}; V_{J \setminus \{j\}})$ and $\psi: U_i \otimes X \rightarrow V_j \otimes X$, the trace of $\langle \Phi \otimes \psi \rangle_t$ is defined by and must be

$$\text{Tr}_{\langle X \rangle_t}(\langle \Phi \otimes \psi \rangle_t) := \begin{cases} (t - \#r)\text{Tr}_X(\psi) \cdot \langle \Phi \rangle_t, & \text{if } i = j = \emptyset, \\ \langle \Phi \otimes \text{Tr}_X(\psi) \rangle_t, & \text{otherwise.} \end{cases}$$

Then these transformations satisfy the axioms of trace. It is easy to prove that every trace on $S_t(C)$ is obtained by this construction. Note that in a braided tensor category the trace we defined satisfies the equation $\text{Tr}_{\langle X \rangle_t}(\tau_C(X, X)) = \langle \text{Tr}_X(\sigma_C(X, X)) \rangle_t$.

A.3. Twists

Definition A.4. A *twist* on a braided tensor category C is a functorial isomorphism $\theta_C(U): U \rightarrow U$ such that $\theta_C(\mathbb{1}_C) = id_{\mathbb{1}_C}$ and $\theta_C(U \otimes V) = \sigma_C(V, U) \circ (\theta_C(V) \otimes \theta_C(U)) \circ \sigma_C(U, V)$. A *balanced tensor category* is a braided tensor category equipped with a twist. It is called a *ribbon category* (or a *tortile category*) if it is rigid and satisfies $\theta_C(U^*) = \theta_C(U)^*$.

For example, each trace in C induces a twist $\theta_C(U) := \text{Tr}_U(\sigma_C(U, U))$. When C is rigid, this trace can be recovered from the pivot

$$U^* \xrightarrow{id_{U^*} \otimes coev_{*U}} U^* \otimes *U \otimes U \xrightarrow{\sigma_C^{-1}(U^*, *U) \otimes \theta_C(U)} *U \otimes U^* \otimes U \xrightarrow{id_{*U} \otimes ev_U} *U$$

so pivots, traces and twists are the same things in a rigid braided tensor category.

Similarly as traces, twists on a braided tensor category \mathcal{C} and those on $\mathcal{S}_t(\mathcal{C})$ are in one to one correspondence via the 2-functor \mathcal{S}_t for transformations with unit. In particular, \mathcal{S}_t also sends a balanced tensor category to a balanced tensor category and a ribbon category to a ribbon category. One of the most interesting application of tensor category theory is that a ribbon category induces an oriented link invariant such as (a constant multiple of) the Jones polynomial or the HOMFLY-PT polynomial. Now let J and J_t be link invariants induced by ribbon categories \mathcal{C} and $\mathcal{S}_t(\mathcal{C})$ respectively. One can prove that the new invariant J_t only depends on J ; for example, $J_t(\text{a knot}) = t \cdot J(\text{a knot})$ and $J_t(\text{a Hopf link}) = (t^2 - t) \cdot J(\text{a Hopf link}) + t \cdot J(\text{two trivial knots})$.

References

- [1] D.J. Benson, Representations and cohomology. I, in: Cambridge Studies in Advanced Mathematics, vol. 30, Cambridge University Press, Cambridge, 1991, Basic representation theory of finite groups and associative algebras.
- [2] M. Bloss, G -colored partition algebras as centralizer algebras of wreath products, *J. Algebra* 265 (2003) 690–710.
- [3] J. Comes, V. Ostrik, On blocks of Deligne’s category $\text{Rep}(\mathcal{S}_t)$, *Adv. Math.* 226 (2011) 1331–1377.
- [4] B. Day, C. Pastro, Note on Frobenius monoidal functors, *New York J. Math.* 14 (2008) 733–742.
- [5] P. Deligne, La catégorie des représentations du groupe symétrique S_t , lorsque t n’est pas un entier naturel, in: Algebraic Groups and Homogeneous Spaces, Tata Inst. Fund. Res. Stud. Math., Tata Inst. Fund. Res., Mumbai, 2007, pp. 209–273.
- [6] P. Etingof, Representation theory in complex rank, Conference talk at the Isaac Newton Institute for Mathematical Sciences, 2009. Available at <http://www.newton.ac.uk/programmes/ALT/seminars/032716301.html>.
- [7] M.H. Freedman, A magnetic model with a possible Chern-Simons phase, *Comm. Math. Phys.* 234 (2003) 129–183. With an appendix by F. Goodman and H. Wenzl.
- [8] W. Fulton, Young tableaux, in: London Mathematical Society Student Texts, vol. 35, Cambridge University Press, Cambridge, 1997, With applications to representation theory and geometry.
- [9] V.F.R. Jones, The Potts model and the symmetric group, in: Subfactors (Kyuzeso, 1993), World Sci. Publ, River Edge, NJ, 1994, pp. 259–267.
- [10] F. Knop, A construction of semisimple tensor categories, *C. R. Math. Acad. Sci. Paris* 343 (2006) 15–18.
- [11] F. Knop, Tensor envelopes of regular categories, *Adv. Math.* 214 (2007) 571–617.
- [12] M. Kosuda, Characterization for the modular party algebra, *J. Knot Theory Ramifications* 17 (2008) 939–960.
- [13] T. Leinster, Higher operads, higher categories, in: London Mathematical Society Lecture Note Series, vol. 298, Cambridge University Press, Cambridge, 2004.
- [14] S. Mac Lane, Categories for the working mathematician, second edition, in: Graduate Texts in Mathematics, vol. 5, Springer-Verlag, New York, 1998.
- [15] P. Martin, Temperley–Lieb algebras for nonplanar statistical mechanics—the partition algebra construction, *J. Knot Theory Ramifications* 3 (1994) 51–82.
- [16] A. Mathew, Categories parametrized by schemes and representation theory in complex rank, 2010. [arXiv:1006.1381](https://arxiv.org/abs/1006.1381).
- [17] M. McCurdy, R. Street, What separable Frobenius monoidal functors preserve? *Cah. Topol. Géom. Différ. Catég.* 51 (2010) 29–50.
- [18] P. Selinger, A survey of graphical languages for monoidal categories, in: B. Coecke (Ed.), *New Structures for Physics*, in: Lecture Notes in Physics, vol. 813, Springer, Berlin, Heidelberg, 2011, pp. 289–355.
- [19] K. Szlachányi, Finite quantum groupoids and inclusions of finite type, in: *Mathematical Physics in Mathematics and Physics* (Siena, 2000), in: Fields Inst. Commun., vol. 30, Amer. Math. Soc., Providence, RI, 2001, pp. 393–407.
- [20] K. Szlachányi, Adjointable monoidal functors and quantum groupoids, in: *Hopf Algebras in Noncommutative Geometry and Physics*, in: Lecture Notes in Pure and Appl. Math., vol. 239, Dekker, New York, 2005, pp. 291–307.