

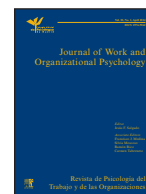

# Journal of Work and Organizational Psychology

[www.elsevier.es/rpto](http://www.elsevier.es/rpto)



## Organizational citizenship behavior, organizational justice, job stress, and work-family conflict: Examination of their interrelationships with respondents from a non-Western culture

Aharon Tziner\* and Gil Sharoni

Netanya Academic College, Israel

### ARTICLE INFORMATION

Manuscript received: 29/08/2013  
Revision received: 10/02/2014  
Accepted: 24/02/2014

#### Keywords:

Work-family conflict  
Organizational citizenship behavior  
Organizational justice  
Job stress

### ABSTRACT

This study proposed two plausible models regarding these inter-relationships: 1) The first model posited a positive relationship between (i) organizational justice and OCB, (ii) stress and OCB, and (iii) work-family conflict and stress. This first model indicates that the variables OCB and stress mediate between organizational justice and work-family conflict. 2) The second model proposes a positive relationship between (i) organizational justice and OCB, (ii) work-family conflict and OCB, and (iii) work-family conflict and stress. This second model points to OCB and work-family conflict as mediators between organizational justice and stress. In sum, drawing upon Arab respondents, our findings partially supported both conceptual models: in both models, the first and third hypotheses were confirmed, namely, that positive associations exist, respectively, between organizational justice and OCB and between work-family conflict and stress. However, for each model a significant negative, rather than positive, association was found for the second hypothesis that predicted a positive correlation between OCB and stress.

© 2014 Colegio Oficial de Psicólogos de Madrid. Production by Elsevier España, S.L. All rights reserved.

## Conducta cívica organizacional, justicia organizacional, estrés laboral y conflicto entre familia y trabajo: análisis de sus interrelaciones en una muestra de cultura no occidental

### RESUMEN

Este estudio propone dos modelos plausibles referentes a una serie de interrelaciones. 1) El primer modelo plantea una relación positiva entre (i) justicia organizacional y conducta cívica organizacional (CCO), (ii) estrés y CCO y (iii) conflicto trabajo-familia y estrés. Este primer modelo indica que las variables CCO y estrés mediatizan la relación entre justicia organizacional y conflicto trabajo-familia. 2) El segundo modelo propone una relación positiva entre (i) justicia organizacional y CCO, (ii) conflicto trabajo-familia y CCO y (iii) conflicto trabajo-familia y estrés. Este segundo modelo apunta al CCO y al conflicto trabajo-familia como mediadores de la justicia organizacional y el estrés. En síntesis, utilizando una muestra árabe nuestros resultados apoyan en parte ambos modelos conceptuales: en ambos se han confirmado la primera y tercera hipótesis, es decir, que hay asociaciones positivas respectivamente entre justicia organizacional y CCO y entre conflicto trabajo-familia y estrés. No obstante, en cada modelo se encontró una asociación significativa negativa más que positiva en la segunda hipótesis que predecía una correlación positiva entre CCO y estrés.

© 2014 Colegio Oficial de Psicólogos de Madrid. Producido por Elsevier España, S.L. Todos los derechos reservados.

#### Palabras clave:

Conflicto familia-trabajo  
Conducta cívica organizacional  
Justicia organizacional  
Estrés laboral

As the pace of industry and organizations rapidly increases in response to ever-expanding and competitive markets, the role of the individual worker's contribution to the work force has become equivalently more critical and the object of scrutiny. In today's

marketplace, where productivity is so critical, managers that want to achieve maximum job performance are already looking at two distinct, but related, aspects of the employee's work life. On the one hand, there is the standard, if not traditional, job description, which defines the worker's formal relationship with his employer. On the other hand, there is a fast emerging new side to the job that incorporates informal optional behaviors that depend on the employee's personal discretion and judgment.

\*Correspondence concerning this article should be addressed to Prof. Dr. Aharon Tziner, Schools of Behavioral Studies and Business Administration, Netanya Academic College, 1. University St Netanya, Israel. E-mail: [atziner@netanya.ac.il](mailto:atziner@netanya.ac.il)

This latter category of work life has become the subject of much recent research in the field of management in organizations. For the most part, the research has indicated that companies benefit when their employees are willing to contribute to the workplace above and beyond what is required of them by the formal requirements of their jobs (Organ, 1988; Podsakoff, Mackenzie, Paine & Bachrach, 2000).

This discretionary behavior, which is neither formally recognized nor rewarded, is termed Organizational Citizenship Behavior (OCB). In the increasingly dynamic and competitive environment in which organizations operate, OCB is considered a highly valuable contribution to the effective functioning of an organization. Indeed, there has been increasing interest in OCB recorded by several management scholars (Podsakoff, Whiting, Podsakoff, & Blume, 2009) who significantly noted that since 2000 no fewer than 400 articles on OCB and related constructs were published.

There are various types of organizational behaviors that can be defined as OCBs. These include altruistically assisting colleagues who have high workloads, preventing conflicts at the workplace, respecting others' rights, following rules and regulations (even if not overseen by supervisors), and not complaining about trivial issues.

Earlier research focused on individual psychological antecedents of OCB such as affective, cognitive, and dispositional factors (e.g., Organ, 1988), while later studies revealed that OCB also correlates highly with employee loyalty and employee identification with organizational goals. Notably, however, the significant underlying thread linking these behaviors is that they result in the facilitation of organizational functioning and productivity (e.g., Podsakoff et al., 2000, 2009). Thus, OCB has been shown to facilitate planning, scheduling, problem solving and the efficient allocation of resources (e.g., Podsakoff et al., 2009).

OCB can be construed in one of two ways: either as an aggregate concept or by referring to its various aspects or dimensions. Accordingly, Organ (1988) proposed a five-dimensional model of OCB consisting of altruism, courtesy, consciousness, civic virtue, and sportsmanship.

Although these studies have contributed to our understanding of altruistic behaviors in the workplace, there appears to be a lack of a singular overarching up-to-date model that outlines (1) how specific factors in the organizational realm affect OCB and (2) how OCB affects the workplace – and beyond, the home and family environment (i.e., the consequences of OCB). The current paper aims to advance two such parallel and appropriate models and to report findings of an empirical investigation that will throw light on the veracity and probable superiority of one model over the other.

In order to arrive at these paradigms, we first describe three pivotal aspects of OCB that have been researched in recent years. These are (1) Organizational Justice, (2) Job Stress, and (3) Work-Family Conflict. From these accounts, which include a review of the antecedents and consequences associated with these phenomena, and we draw hypotheses that form the basis of these two, competing, models.

### Antecedents and Consequences of OCB

**Organizational justice.** Research literature has consistently shown that perceptions of organizational justice or injustice are a key factor affecting the attitudes and behaviors of individuals in organizations (Cole, Bernerth, Walter, & Holt, 2010). The construct 'organizational justice' generally refers to three specific components, namely, distributive justice, procedural justice, and interactional justice. Traditionally, the notion of *distributive justice* is based on a general theory of fairness, which offers a broad explanation of the motives underlying the actions of individuals. In particular, Adams (1965) argues that individuals determine a value for the ratio between the outcomes of their work and the inputs they invest. The results are (i) material compensation manifested in wages and

benefits and (ii) non-material compensation, such as social recognition, enhanced interest in the work, and the greater potential to fulfill oneself. It has been argued that the cardinal aspect of distribution is that the individual worker believes that fairness exists in the allocation of rewards in the organization. Thus, workers consider reward distribution to be fair if it is based on rules that are acknowledged as just, such as an acceptable balance between employees' contributions and their compensation. It can also be contended that workers consider reward distribution to be fair when they perceive equitable distribution of resources in the organization to peers or other employees whose jobs are comparable to theirs.

In a similar fashion, *procedural justice* relates to perceived fairness in the processes through which decisions are reached. Notably, procedural justice comprises both subjective aspects, such as the manner in which a specific procedure is perceived, and objective aspects such as the way in which a specific procedure is carried out *de facto*. In certain situations a clash, or a partial or full overlap, may transpire between these subjective and objective aspects. The possibility of partial or complete incongruity between these subjective and objective factors has implications regarding the way in which procedural justice perceptions can be changed.

The third component of justice perception is *interactional justice*, which is divided into two main components: (1) the interpersonal, which defines the degree to which employees are given proper and respectful treatment in the organization and (2) the informational, which defines the extent to which explanations given are compatible with the decisions reached. These two components reflect the extent of respect that employees feel they are given by the organization and its managers. Interactional justice is generally regarded as the dimension that complements procedural justice.

The interpersonal component, which reflects the attitudes of decision-makers to subordinates, is one of the most significant parameters considered by workers when it comes to perceptions of justice within their organizations. The many different facets that contribute to these employee judgments include both general and specific impressions as to how the decision makers respect others, give consideration to the attitudes and feelings of their subordinates, and approach and communicate their decisions to the staff working under them. In addition to understanding the theoretical underpinnings of each of these dimensions, it is critical to investigate how individuals process judgments within each of these categories in order to discern what effects these perceptions have on various aspects of work behavior, including OCB.

**Consequences of perceived justice.** In the first place, research has shown that perceived justice affects attitudes towards work. Employees who perceive the workplace as fair are more satisfied with their work are more committed to the organization, are more likely to rely on their superiors, and display a greater desire to retain their jobs (e.g., Loi, Yang, & Diefendorf, 2009). In contrast, employees who perceive injustice at work engender negative attitudes toward their organizations suffer from reduced personal welfare and achieve lower levels of daily functioning (Bobocel & Hafer, 2007).

Specifically, research has consistently pointed to a positive association between perceptions of organizational justice and OCB, indicating higher OCB manifestations among employees who perceived that the organization and its leaders treated them fairly (while the converse relationship also held true). This global conclusion is in line with a string of previous findings spanning many years (Colquitt, Conlon, Wesson, Porter, & Ng, 2001; Konovsky & Pugh, 1994; Moorman, 1991; Moorman, Blakely, & Niehoff, 1998; Niehoff & Moorman, 1993), which significantly demonstrate how workers who perceive organizational decision-making and implementation processes as fair consequently benefit the overall efficiency of the organization through these informal and "extracurricular" behaviors.

These studies lead us to propose our first hypothesis, namely:

*Hypothesis 1: Organizational justice will associate positively to OCB.*

**Job stress.** Job stress has received extensive theoretical and research attention. Once employees perceive any work situation as presenting demands that threaten to exceed their capabilities and resources for meeting them – or as being too costly if not met – they are expected to assess the situation as stressful. These perceptions are, of course, very subjective; the stress is in “the eye of the beholder”.

Drawing on the Work Adjustment Theory, Tziner and Dawis (1988) contended that the adjustment of individuals to work environments could be described in terms of the mutual responsiveness/corresponsiveness of both the individual and the environment to each other. To infer the state of *corresponsiveness*, it is necessary to describe both the individual and the environment in the same commensurate terms, but with data obtained independently for each. From the perspective of the individual, these commensurate terms are “abilities” and “preferences for rewards”, while on the environment side they incorporate “ability requirements” and “reinforcement potential”. The terms “preferences for rewards” and “reinforcement potential” imply that the worker has a certain potential value to the environment. Thus, applying this corresponsiveness approach one could posit that the degree of occupational stress at any given time would be determined by the respective concurrent levels of ability and value or discordance between the perspective of the employee and his working environment, i.e., his direct superior or employer, as the case may be.

**OCB and stress.** Stress at the workplace has become an important issue because its consequences can take a heavy toll on organizations and their employees (Francis & Barling, 2005; Hart & Cooper, 2001) and high levels of stress can impair workers' performance and result in negative behavioral and attitudinal work outcomes (Oplatka, 2009). Of interest, recent studies have also shown that despite a positive relationship between OCB and satisfaction, high levels of OCB can have a negative impact on the individual (Bergeron, 2007; Bolino & Turnley, 2005; Bolino, Turnley, & Niehoff, 2004; Bolino, Turnley, Gilstarp, & Suazo, 2010).

Bolino and Turnley (2005) explained the high frequency of this seemingly unusual correlation by suggesting that OCB requires an individual worker to fill a number of roles simultaneously. Thus, employees who exhibit high OCB in addition to their formal job could be subject to work overload and consequently perceive their work as stressful. Furthermore, employees who exhibit high OCB might well experience role conflict and ambiguity regarding their actual job definition that could also contribute to their perception of stress at work (Belogolovsky & Somech, 2010).

COR is a general stress theory that is based on the premise that individuals seek to preserve, renew, and enhance their resources – and when they cannot do so, they experience stress. In other words, stress occurs when resources are perceived as unstable, threatened or lost, or when individuals are unable to attain or preserve resources with available means (Hobfoll, 2001). Resources are defined as objective personal characteristics, conditions, or energies that are valued in themselves or because they contribute to achieving or preserving valued resources. COR Theory has been suggested as an integrative stress theory, which includes both the worker's subjective processes (i.e., personality attributes such as locus of control and flexibility, which might exert influence on the perception of stress at work) and objective or external environmental sources of stress (e.g., inherent extreme or noxious stimuli such as risk of physical harm, extreme temperature work conditions). Based on this theory, Bergeron (2007) claimed that as OCB is a behavior that exceeds the bounds of the official job, it robs the worker of many resources that

are required to fulfill the formal job, thus leaving the worker with less resources to devote to the regular tasks, which, in turn, increases the sense of stress (Cropanzano & Byrne, 2000).

Recently, Bolino et al. (2010) drew attention to a new phenomenon in organizations, namely, that of managers encouraging OCB by means of organizational norms and culture, employee performance evaluation, and stories that highlight the expected beyond-duty behavior (OCB), thus putting pressure on employees to engage actively in OCB. This inflated sense of duty to perform activities that are defined as OCB and that are not part of the formal job requirements increases the employees' stress levels. In other words, if a worker feels *obligated* to behave in a certain way, his/her sense of stress increases.

These research findings lead us to our second hypothesis, namely,

*Hypothesis 2: OCB will relate positively to stress.*

**Work-family conflict.** As the demands of the workplace increase in our technologically advanced societies, so are the pressures upon workers becoming increasingly tough and harder to bear. Although there may be individual differences regarding employees' reactions to stress at work, it is probably fair to say that individuals spend many more hours invested in work than in the previous generation, and that stress at work is increasingly likely to affect their productivity. However, as has become increasingly acknowledged, these pressures also affect family life (Greenhaus & Beutell, 1985).

Workers tend to be torn between demands at home and pressures at work. One of the major concomitants of this conflict is the difficult challenge of dividing one's resources – especially time – between the demands of work and family. The ultimate question is how to allocate personal resources effectively between work and home. It seems, at least in Western industrialized societies, that resources invested in the job by individual workers are becoming increasingly less available to their families. The result is the greater likelihood of conflicts between work and family.

This notion is borne out by Greenhaus and Beutell (1985), who defined the work-family conflict as a type of *inter-role* conflict in which the pressures of work and family are mutually incompatible in a number of ways. Consequently, performing the job at work becomes more difficult when it clashes with demands at home and coping with family matters correspondingly becomes more challenging when work pressures increase. The work-family conflict could also be viewed as an *intra-role* conflict, whereby the pressures emanating from work roles are seen as not only incompatible with family demands but also as competing with pressures in other areas of life. Kossek, Noe, and DeMarr (1999) refined this definition even further by stressing the extent to which taking part in one role clashes with the ability to fulfill the obligations of one or several other roles.

Specifically, it has been found useful to define three major types of work-family conflicts (Greenhaus and Beutell (1895). These are (1) *time-based conflict*, whereby time expended in one domain precludes time spent in the other in such a way as to deplete energy and to create stress; (2) *strained-based conflict*, whereby the stress in one role affects performance in another role; and (3) *behavior-based conflict*, which refers to incompatibility between the various and desirable behavior patterns in the two competing domains.

Lastly, we note the different types of pressure on the individual that have been identified as sources of the work-family conflict. At work, these include external, *objective* pressures in the individual's job environment such as expectations that are communicated by peers in the person's role set or work demands such as the excessive job overloads and time pressures associated with rush jobs and deadlines (Frone, Russell, & Cooper, 1992). Notably, as already indicated, these pressures have to be perceived by the individuals in

order for them to be reckoned as objective pressures that affect role performance. Alternately, there are perceived *subjective* pressures that exist within the individual's own psychological environment that are largely the product of the person's socialization (see below). In contradistinction to work demands, family demands can be exemplified by time pressures associated with housekeeping and child care or responsibilities to elderly parents; but, clearly, there are many different demands impinging on family members, according to various circumstances operating at any one time.

**Work-family conflict and stress.** Moving beyond definitions, recent research has given much attention to the relationship between the work-family conflict and stress. Indeed, there is much evidence that the work-family conflict has a significant impact on the individual's physical, behavioral and cognitive-emotional wellbeing (Kirrane & Buckley, 2004), with one of the most significant negative outcomes expressed as increased stress at work (Frone et al., 1992).

Many scholars tend to focus on examining stressors at the workplace as a primary source of the work-family conflict because employees have relatively little control over their work life, in contrast to the relatively high degree of management they can exert in the home situation (Higgins & Duxbury, 1992). Of course, the degree to which family-related pressures exert themselves on an individual may well be a function of the specific circumstances of both the individual and the family. Thus, a person's age and maturity, number of children and other dependents, are factors that impinge, among others, on the individual's ability to cope.

Cultural factors also play a part in how stress is perceived and managed at the workplace and how the overall family copes with work-related pressures. It has been noted that work and family pressures reflect social expectations and self-expectations, which are most susceptible to values, beliefs, and role-related self-conceptions internalized through socialization. It appears that these role-related self-conceptions have a direct impact on the perceived demands within the domain – work, family, other – and that demands and pressures will be perceived as greater in the domain with the highest priority. To put it more succinctly, a person becomes more ego-involved, and invests more time and energy, in the high priority domain.

How these priorities are fixed is an interesting study in itself and is clearly culturally based. For instance, cross-cultural studies have found that Eastern societies give greater priority to work than do Western societies. Indeed, it was found that despite popular images of Americans as career-oriented, Western families in individualistic societies valued family and personal time more strongly than Eastern collective societies: when work and family conflict, Americans are expected to side with family and cannot necessarily expect support from their family members (Adams, King, & King, 1996). The family, it appears, is central to the American emphasis on the quality of life and much research has shown that it has a greater impact than work on the psychological well-being of workers in North America and Western Europe.

All this does not mean that work and work pressures are insignificant to the mental health and productive functioning of individuals in Western societies. Studies have consistently found a positive relationship between work-related stress factors (such as role ambiguity, role conflicts, and overload) and work-family conflicts (Bacharach, Bamberger, & Conley, 1991; Frone, Russell, & Cooper, 1997; Fu & Schaffer, 2001; Greenhaus & Beutell, 1985; Parasuraman, Purhoit, Godshalk, & Beutell, 1996). Hughes and Galinsky (1994), for example, found that individuals who experience stress at work, demands for high output, and lack of a supportive work relationship reported negative moods at home and a higher frequency of disagreements in their marriage. In this respect, the 'spillover model' is helpful: It indicates specifically that psychological reactions to work, such as satisfaction or emptiness, are transferred to family life

(Repetti, 1989). For instance, Jones and Fletcher (1996) used the model to describe the effects of both husbands' and wives' work-related stress on their personal, psychological, and physical welfare.

In related investigations, where workers complained of being torn between work life and family life and unable to perform adequately in either world, their confused emotions affected their behavior both at work and at home, resulting in even more stress. However, when individuals struck a balance and found a *modus vivendi* between the demands of home and work stress decreased concomitantly (Adams, King & King, 1996; Anderson, Coffey, & Byerly, 2002; Frone et al, 1992; Greenhaus & Powell, 2006; Madsen, 2006).

Based on the above discussion, we hypothesize that:

*Hypothesis 3 (Model #1): Work-family conflict will relate positively to stress.*

Alternatively, we propose that stress determines the level of experienced work-family conflict. Thus, we may suggest an equally likely proposition, that:

*Hypothesis 3 (Model #2): Stress will positively affect work-family conflict.*

### Summary of Research Hypotheses

The following hypotheses are based on the above literature review and derive from it. They generate two parallel, but competing, explanatory models.

#### Model #1:

*Hypothesis 1: Organizational justice will associate positively to OCB.*

*Hypothesis 2: Perception of stress will relate positively to OCB.*

*Hypothesis 3: Work-family conflict will relate positively to stress.*

#### Model #2:

*Hypothesis 1: Organizational justice will associate positively to OCB.*

*Hypothesis 2: Work-family conflict will relate positively to OCB.*

*Hypothesis 3: Stress will positively affect work-family conflict.*

The purpose of the present study is to examine the relationships between these variables and to investigate which of the competing models offers a more valid and rigorous description of the relationships between the variables of the study. The subjects were drawn from a sample of Arab respondents in Israel.

## Method

### Participants

The data were collected from 120 from Arab respondents, of whom 22.5% were men and 77.5% women. Their mean of age was 39.1 years ( $SD = 8.73$ ). The mean tenure in the present organization was  $M = 15.23$  years ( $SD = 9.5$ ). 1.7% had above high school education, 80.8% held a BA degree, and 17.5% an MA degree; 87.5% were married, 10.8% were single and 1.75% - widowed.

### Measures

**Organizational citizenship behavior (OCB)** was tapped by means of the 20-item scale employed by Niehoff and Moorman (1993). Sample items included: "I help other employees who have heavy workloads" or "I never take long lunches or breaks." Responses were marked on a 6-point scale ranging from 1 (strongly disagree) to 6 (strongly agree). Cronbach's alpha coefficient for the instrument in the current sample was .83 ( $M = 4.72$ ,  $SD = 0.59$ ).

**Organizational justice** perceptions were also assessed using the 20-item scale employed by Niehoff and Moorman (1993). Sample items included: "I think that my level of pay is fair" or "Job decisions are made by the general manager in an unbiased manner." Participants indicated the degree to which they believed each statement was descriptive of the reality in their organization, marking their responses on a 6-point scale ranging from 1 (strongly disagree) to 6 (strongly agree). Cronbach's alpha was .92 ( $M = 4.46$ ,  $SD = 0.70$ ). We used a global measure because we intended to capture and examine the effect of the overall perception of justice rather than of its individual components (e.g., distributional).

**Stress** was gauged using a 14-item scale developed by Dupuy (1977). Sample items included: "I experienced a low mood during the last year " or "I felt tense and under pressure during the last year". Participants indicated the frequency with which they experienced the situation described by each item using a 6-point Likert scale ranging from 1 (never) to 6 (all the time). Cronbach's alpha was .92 ( $M = 2.61$ ,  $SD = 0.86$ ).

**Work-family conflict** was tapped with Carlson, Kacmar and Williams' (2000) 18-item instrument. Sample items included: "My work distances me from family-related activities" or "I miss family-related events because I am overburdened with work duties". The respondents were asked to mark the degree to which each statement described their personal experience using a 6-point Likert scale with 1 (strongly disagree) to 6 (strongly agree). Cronbach's alpha was .93 ( $M = 3.38$ ,  $SD = 0.84$ ).

(thereby corroborating Hypothesis 3) and work-family conflict ( $r = -.55$ ,  $p < .01$ ;  $-.39$ ,  $p < .05$ , respectively). Finally, as expected, work-family conflict was found to correlate strongly positively with stress. Thus, Hypothesis 2 received full empirical support.

Confirmatory factor analysis was run in order to examine the veracity of the entire set of relationships between this study's variables as a whole, according to Model 1 and Model 2, respectively. The results relating to Model 1 are displayed in Figure 1.

The chi-square ( $\chi^2$ ) test is normally used as a first step to measure model fit. Because the null hypothesis for the overall model fit states that *the model fits the data*, the probability ( $p$ ) value of  $\chi^2$  should be insignificant. The  $p$  value associated with  $\chi^2$  represents the likelihood of obtaining a  $\chi^2$  value that exceeds the critical region value when the null hypothesis is true. In this regard, if the  $p$  value of  $\chi^2$  is less than the conventional threshold (cutting point) of 0.05 then the model is rejected; otherwise it is accepted (Ullman, 2007). In this study,  $\chi^2(2) = 0.59$ ,  $p = .769$ , CFI = 1.0, NFI = .99 (both indices – CFI and NFI – are above .95). The root mean square error of approximation (RMSEA) = .000 is well below .05. Figure 1 reveals that organizational justice affects OCB strongly positively ( $\beta = .44$ ,  $p < .01$ ). OCB turned out strongly negatively related to stress ( $\beta = -.44$ ,  $p < .01$ ) and stress emerged very strongly positively impinging on work-family conflict ( $\beta = .71$ ,  $p < .01$ ). Thus, all hypothesized relationships of Model 1 were upheld. Additionally, a direct association has unfolded between organizational justice and stress, a significant negative one ( $\beta = -.25$ ,  $p < .01$ ), thereby leading to the conclusion that organizational justice affects stress both directly and through the mediation of OCB.

We proceed now with the examination of Model 2.

Inspecting the findings, we note that as in Model 1, organizational justice links strongly positively with OCB ( $\beta = .44$ ,  $p < .01$ ); OCB associates strongly negatively with work-family conflict ( $\beta = -.39$ ,  $p < .01$ ); and work-family conflict associates strongly positively with stress ( $\beta = .57$ ,  $p < .01$ ). Consequently, all the hypotheses of this model were also confirmed. Moreover, organizational justice entertains a direct negative relationship with stress ( $\beta = -.18$ ,  $p < .01$ ) and OCB also displays a strong negative link to stress ( $\beta = -.26$ ,  $p < .01$ ).

The entire model fits the data as follows:  $1.77$ ,  $p = .184$ , CFI = .995, NFI = .989 and RAMSEA = .08. Clearly, Model 1 proves to be superior to Model 2 because it offers a better fit.

**Results**

Table 1 provides the descriptive statistics of the study variables.

**Table 1**  
Means, standard deviations, and correlations among study variables

|                           | Mean | SD   | 1       | 2       | 3      | 4    |
|---------------------------|------|------|---------|---------|--------|------|
| 1. Organizational Justice | 4.46 | 0.70 | 0.92    |         |        |      |
| 2. OCB                    | 4.72 | 0.59 | 0.44**  | 0.83    |        |      |
| 3. Stress                 | 2.61 | 0.86 | -0.44** | -0.55** | 0.92   |      |
| 4. Work Family Conflict   | 3.38 | 0.84 | -0.57** | -0.39   | 0.71** | 0.93 |

Note.  $N = 120$ , \* $p < .05$ , \*\* $p < .01$

Table 1 indicates that organizational justice correlates positively strongly with OCB, (confirmation of Hypothesis 1) and negatively strongly with both stress and work-family conflict ( $r = .44$ ,  $p < .01$ ;  $r = -.44$ ,  $p < .01$ ;  $-.57$ ,  $p < .01$ ; respectively). Additionally, it emerges from Table 1 that OCB relates negatively strongly to both stress

**Discussion**

In an attempt to approach a plausible model of the relationship between a number of variables that impinge on work relationships and productivity, this paper reviews the relationships between organizational justice, OCB, stress, and work-family conflict, as they were expressed by a corpus of Arab respondents. In particular, we sought to examine how specific factors in the organizational realm

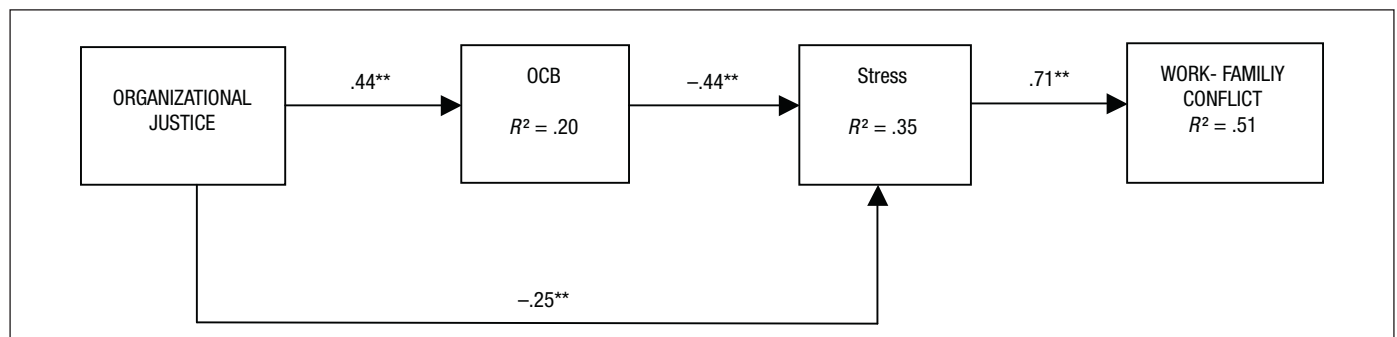

**Figure 1.** Model #1 - Structural Equation Model and Standardized Path Estimates for Organizational Justice, Organizational Citizenship Behavior, Stress and Work- Family Conflict \*\* $p < .01$

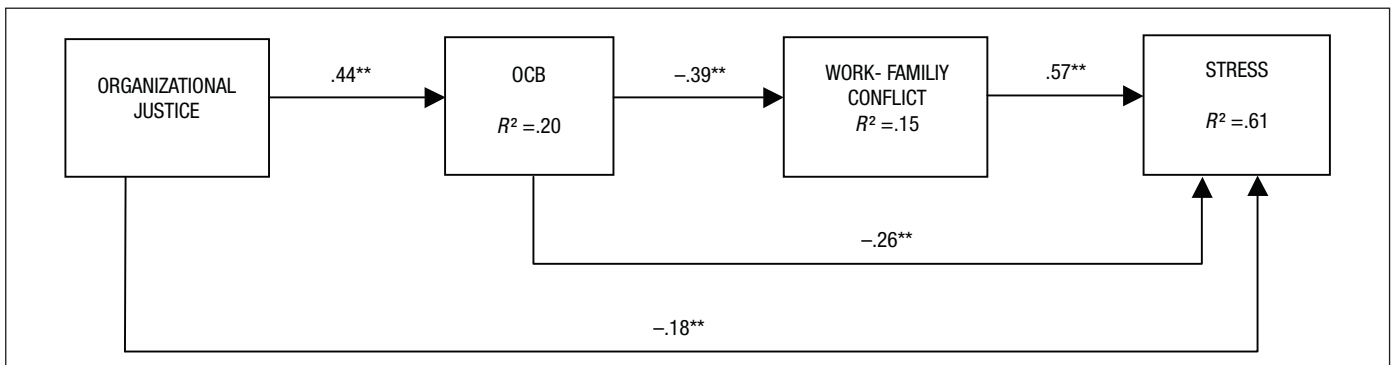

**Figure 2.** Model #2 - Structural Equation Model and Standardized Path Estimates for Organizational Justice, Organizational Citizenship Behavior, Work-Family Conflict and Stress. \*\* $p < .01$

affect OCB and how OCB affects the workplace and the home, and vice versa.

This study proposed two plausible models regarding these inter-relationships:

1. The first model posited (i) a positive relationship between organizational justice and OCB, (ii) a negative relationship between stress and OCB, and (iii) a positive relationship between work-family conflict and stress. This model indicates that the variables OCB and stress mediate between organizational justice and work-family conflict.
2. The second model proposes (i) a positive relationship between organizational justice and OCB, (ii) a negative relationship between work-family conflict and OCB, and (iii) a positive relationship between stress and work-family conflict (i.e., stress is likely to lead to work-family conflict rather than the opposite). This second model points to OCB and work-family conflict as mediators between organizational justice and stress.

In sum, our findings partially supported both conceptual models: In both models, the first and third hypotheses were confirmed, namely, that positive associations exist, respectively, between organizational justice and OCB and between work-family conflict and stress. However, for each model a significant *negative*, rather than positive, association was found for the second hypothesis that predicted a positive correlation between OCB and stress.

The statistical results also offer an opportunity to see which of the two models is the more rigorous and offers a more valid description of the relationships between the investigated variables of the study. In this respect, as indicated above, the first model was found to be a superior fit than the second model.

We shall now discuss the implications of these specific findings according to the proposed hypotheses, with emphasis on the more rigorous of the two models, namely the first model.

### The First Model

The first hypothesis was upheld, namely, a positive relationship was found between organizational justice and OCB, implying, as discussed, that the more individuals perceive their organizations as just, the higher the levels of OCB they exhibit and vice versa. From these specific findings and the extensive research on this subject we can easily reiterate the conclusion that managers in organizations should serve as role models for their subordinates. If managers treat their employees with respect, justice, support, sharing, and teaching, then the employees, in turn, treat the organization respectfully and take their jobs seriously. In this respect, the relationship between managers and employees can be viewed as one of a mutual exchange of respect, caring and communication, factors that go a long way to establishing workers' sense of fairness.

Of more specific interest is our observation that the second hypothesis of the first model was *not* confirmed; rather, a significant negative relationship was found between stress and OCB. In other words, OCBs, minimally, did not cause the respondents to perceive work-related stress and, maximally, they actually contributed to the well-being of the subjects studied, as well as contributing to the overall productivity of the workplace. Thus our finding does not correspond with those many studies cited above that found a positive association between OCBs and the personal *negative* price employees pay for these behaviors.

There are several possible explanations for this specific finding in the present study. Perhaps at the simplest level, we recall that negative effects on employees' welfare and productivity occur only when OCBs are exhibited at a *high* level (Bergeron, 2007; Bolino & Turnley, 2005; Bolino et al., 2004; Bolino et al., 2010). We suggest, therefore, that the degree of OCB that featured among the respondents in our study was, perhaps, not sufficiently high to produce negative concomitants such as work dissatisfaction or high levels of stress.

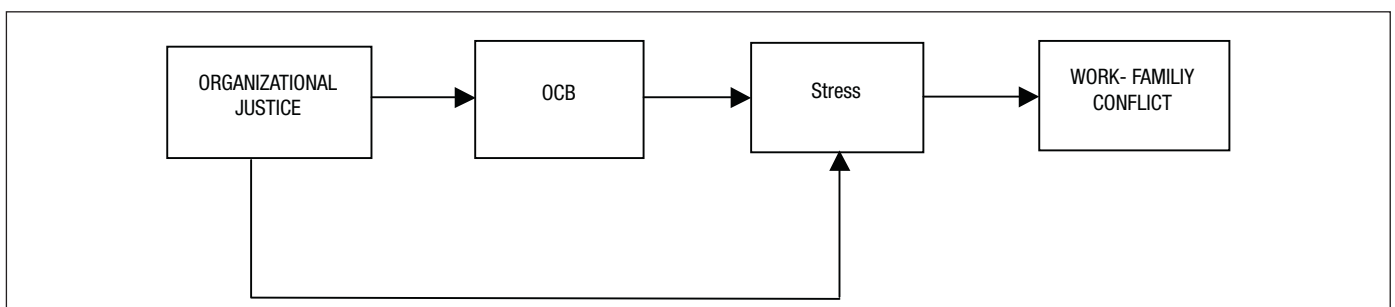

**Figure 3.** Suggested model (Model #1)

With respect to our opening observations on the influence of social and cultural factors on the work ethic, we could possibly explain our results as partially deriving from a very high aspiration level of achievement or, perhaps, an unwillingness of the Arab respondents to share negative outcomes as a minority group in a wider culture.

The third hypothesis of the first model was substantiated, i.e., a positive relationship was found between work-family conflict and stress, in line with the cited studies that consistently revealed a positive relationship between work-related stress factors and work-family conflict. That is to say, the higher the stress experienced by employees, the more work-family conflict they experience, and the lower the stress, the less they experience work-family conflict. This can be explained by the 'spillover model', such that if the subjects experience minimal stress at work this state of mind is reflected in their home life, which in turn reduces the work-family conflict.

In addition to the above-mentioned findings relating to the first model, we also found an impact of perceived organizational justice on stress, namely, that the higher the level of organizational justice, the less the respondents experience stress, confirming studies alluded to above such as Bobocel and Hafer (2007).

In summing up the first model, we found that the variables were linked in the following way: greater perceived organizational justice directly affects OCB (which increases) and stress (which diminishes). As indicated, we also found an *indirect* influence of organizational justice on stress, mediated by OCB. These findings translate as follows: The more organizational justice is perceived, the greater the likelihood that OCB increases. This increased OCB subsequently reduces stress. Stress directly impacts work-family conflict, so that when stress decreases, the respondents experience less work-family conflict. Thus, perceived organizational justice affects the work-family conflict in two ways: 1) with stress as a mediator, and 2) with OCB and stress as mediators.

## The Second Model

In the second model, the findings indicate a positive relationship between organizational justice and OCB, a negative relationship between OCB and work-family conflict, and a positive relationship between work-family conflict and stress.

The first hypothesis is identical in both models and was discussed in full. As was the case with the first model, the second hypothesis of the second model was also not confirmed, namely, OCB was not found to relate positively to work-family conflict; on the contrary, a significant negative relationship was found. And, equivalently, this result does not corroborate the studies of Bolino et al. (2010) and Oplatka (2006), among others, that revealed a positive relationship between OCB and work-family conflict.

Concerning our second model, however, the negative finding might also be explained by assuming that there are additional covariant factors – such as social support – that were not examined in the present study and that relate to the interactions between the variables. For example, as noted in the opening remarks, the emotional and practical support and assistance offered to stressed employees by their families is an invaluable resource that helps individuals cope with the daily challenges of fulfilling roles in both work and home (Adams et al., 1996). Consequently, we could argue that the higher the perception of organizational justice and the more they perform OCBs *with the support of their immediate family*, the less work-family conflict they will experience.

Interesting to note is the further possibility that the reduced stress levels found in our study may also be partly explained by the mediation of the social support variable between stress and OCB (see the second hypothesis of Model #1). As an aside, we might add that a relatively novel aspect of social support is the cellular phone that enables people with intensive schedules to stay in touch with their

families when they cannot be physically present at home. This, naturally, contributes to a decline in work-family conflict which may well be better reflected in future (longitudinal) studies, whereby similar groups of subjects demonstrate increasingly less work-family stress as a result of improved tools of social communication.

The third hypothesis of the second model was substantiated, that is to say that a positive relationship was found between stress and work-family conflict, in line with the extensive cited literature on the subject.

In addition to the above findings of the second model, we also found *direct* influence of OCB on stress, so that the higher the degree of OCBs that our respondents undertake the less stress they experience (as was noted above in the discussion of the second hypothesis in the first model).

To sum up the second model, the four variables could be linked in the following way: greater perceived organizational justice directly affects OCB, which increases. When OCB increases, it affects stress directly and indirectly, directly by causing stress to decrease, and indirectly so that respondents who exhibit more OCB experience less work-family conflict, which in turn decreases stress. In summary, perceived organizational justice affects stress in two ways: 1) with OCB as a mediator and 2) with OCB and work-family conflict as mediators.

Both models reveal that organizations and their principals have a vested interest in maintaining their employees' loyalty and performance levels so that the organizations are able to cope with challenges successfully and achieve their goals.

In general, perceived organizational justice affects employees' behavior, satisfaction, esteem, loyalty, and commitment to the organization and its leaders. One of the by-products of organizational justice is OCB, which contributes to the organization's success and expresses the employees' loyalty and commitment to the organization's goals. Devoted employees who do more than their formal job definition help to increase productivity, efficiency, and the positive atmosphere in the organization, which in turn promote organizational success.

As indicated, if organizations and managers wish to promote OCBs in order to increase organizational effectiveness, they must, first and foremost, uphold a high level of organizational justice.

We noted the effect of the various work stressors on the work-family relationship (and vice-versa), a topic that appears to be an increasingly dominant area of research. In particular, we suggested that several undisclosed factors that affect the work-family relationship, such as social support, might be further complementary factors worth investigating, as the approach towards an all-inclusive model of work relationships continues.

## Conclusions and Recommendations for Future Research

The results of the first model indicate that there is a positive relationship between organizational justice and OCB, a negative relationship between OCB and stress, and a positive relationship between stress and work-family conflict. The results of the second model indicate that there is a positive relationship between organizational justice and OCB, a negative relationship between OCB and work-family conflict, and a positive relationship between work-family conflict and stress.

We recommend performing similar studies that continue to examine the relationships between these variables. However, in future research, the following factors should be considered:

1. This particular investigation is a cross-sectional study at a specific point in time, so that causal conclusions could not be drawn. A longitudinal study would help provide information about changes in attitudes and relationships over time, and additionally support the investigation of the influence of

cultural contexts as they impinge on subjective feelings and attitudes at work.

2. Further research should examine respondents in a variety of sectors and geographic locations. In general, in the context of cross-cultural studies, differences between various cultural norms and those of other Western societies are also worth exploring.
3. In this respect, there was the possibility of social compliance, i.e., the subjects in this study responded to questions with answers that they thought were acceptable but were not necessarily representative of their true feelings. Future research should employ enhanced methodology for establishing both the reliability and validity of subjects' responses.
4. The study sampled only 120 interviewees, a relatively small and unrepresentative sample. Clearly, similar studies on a more extensive scale will help establish both the reliability and validity of the current findings and better serve the goals of reaching an all-encompassing model of the relationship between the investigated variables in the workplace.
5. Future studies in this field might increase the search for confounding variables, such as social support, that possibly cloud the interpretation of the empirical observations. This is particularly germane with respect to the work-family association, an area that is becoming increasingly relevant in Western, industrialized societies and those, like Israel, where family values are very highly prized.
6. In order for the implications of studies like this to have practical consequences for the future welfare of workers in organizations and their efficient functioning, ongoing research should increasingly reflect the attempt to seek out causality in the relationships between the variables.

### Conflict of Interest

The authors of this article declare no conflicts of interest.

### References

- Adams, G. A., King, L. A., & King, D. W. (1996). Relationships of job and family involvement, family social support, and work-family conflict with job and life satisfaction. *Journal of Applied Psychology, 81*, 411-420.
- Adams, J. S. (1965). Inequity in social exchange. In: L. Berkowitz (Ed.), *Advances in experimental social psychology* (Vol. 2, pp. 267-299). New York: Academic Press.
- Anderson, S. E., Coffey, B. S., & Byerly, R. T. (2002). Formal organizational initiatives and informal workplace practices: A review and agenda for future research. *Journal of Occupational Health Psychology, 5*, 278-308.
- Bacharach, S. B., Bamberger, P., & Conley, S. (1991). Work-home conflict among nurses and engineers: Mediating the impact of role stress on burnout and satisfaction at work. *Journal of Organizational Behavior, 12*, 39-53.
- Belogolovsky, E., & Somech, A. (2010). Teachers' organizational citizenship behavior: Examining the boundary between in-role behavior and extra-role behavior from the perspective of teachers, principals and parents. *Teaching and Teacher Education, 26*, 914-923.
- Bergeron, D. M. (2007). The potential paradox of organizational citizenship behavior: Good citizens at what cost? *Academy of Management Review, 32*, 1078-1095.
- Bobocel, D. R., & Hafer, C. L. (2007). Justice motive theory and the study of justice in work organizations: A conceptual integration. *European Psychologist, 12*, 283-289.
- Bolino, M. C., & Turnley, W. H. (2005). The personal costs of citizenship behavior: The relationship between individual initiative and role overload, job stress and work-family conflict. *Journal of Applied Psychology, 90*, 740-748.
- Bolino, M. C., Turnley, W. H., & Niehoff, B. P. (2004). The other side of the story: Reexamining prevailing assumptions about organizational citizenship behavior. *Human Resource Management Review, 14*, 229-246.
- Bolino, M. C., Turnley, W. H., Gilstarp, J. B., & Suazo, M. M. (2010). Citizenship under pressure: What's a 'good soldier' to do? *Journal of Organizational Behavior, 5*, 835-855.
- Carlson, D. S., Kacmar, K. M., & Williams, L. J. (2000). Construction and initial validation of a multidimensional measure of work-family conflict. *Journal of Vocational Behavior, 56*, 249-276.
- Cole, M. S., Bernerth, J. B., Walter, F., & Holt, D. T. (2010). Organizational justice and individuals' withdrawal: Unlocking the influence of emotional exhaustion. *Journal of Management Studies, 47*, 367-390.
- Colquitt, J. A., Conlon, D. E., Wesson, M. J., Porter, C. O., & Ng, K. Y. (2001). Justice at the millennium: A meta-analytic review of 25 years of organizational justice research. *Journal of Applied Psychology, 86*, 425-445.
- Cropanzano, R., & Byrne, Z. S. (2000). *The relationship of emotional exhaustion to work attitudes, job performance ratings, and organizational citizenship behaviors*. The 15<sup>th</sup> Annual Conference of the Society for Industrial and Organizational Psychology in New Orleans, LA.
- Dupuy, H. J. (1977). The general wellbeing schedule. In: I. McDowell & C. Newell (1987), *Measuring health: A guide to rating scales and questionnaires*. New York: Oxford University Press.
- Francis, L., & Barling, J. (2005). Organizational injustice and psychological strain. *Canadian Journal of Behavioral Science, 37*, 250-261.
- Frone, M. R., Russell, M., & Cooper, M. L. (1992). Antecedents and outcomes of work-family conflict: Testing a model of the work-family interface. *Journal of Applied Psychology, 77*, 65-78.
- Frone, M. R., Russell, M., & Cooper, M. L. (1997). Relationship of work-family conflict to health outcomes: A four-year longitudinal study of employed parents. *Journal of Occupational and Organizational Psychology, 70*, 325-335.
- Fu, C. K., & Schaffer, M. A. (2001). The tug of work and family: Direct and indirect domain-specific determinants of work-family conflict. *Personnel Review, 30*, 502-522.
- Greenhaus, J. H., & Beutell, N. J. (1985). Sources of conflict between work and family roles. *Academy of Management Review, 10*(1), 76-88.
- Greenhaus, J. H., & Powell, G. N. (2006). When work and family are allies: A theory of work-family enrichment. *Academy of Management Review, 31*(1), 72-92.
- Hart, P. M., & Cooper, C. C. (2001). Occupational stress: Toward a more integrated framework. In: N. Anderson, D. S. Ones, H. K. Sinangil, & C. Viswesvaran (Eds.), *Handbook of Industrial, Work and Organizational Psychology* (Vol. 2, pp. 93-114). Belmont, CA: Thompson Wadsworth.
- Higgins, C. A., & Duxbury, L. E. (1992). Work-family conflict: A comparison of dual-career and traditional-career men. *Journal of Occupational Behavior, 13*, 389-411.
- Hobfoll, S. E. (2001). The influence of culture, community and nested-self in the stress process: Advancing conservation of resources theory. *Applied Psychology: an International Review, 50*, 337-421.
- Hughes, D., & Galinsky, E. (1994). Work experiences and marital interactions: Elaborating the complexity of work. *Journal of Organizational Behavior, 15*, 423-438.
- Jones, F., & Fletcher, B. (1996). Taking work home: A study of daily fluctuations in work stressors, effects on moods and impacts on marital partners. *Journal of Occupational and Organizational Psychology, 69*, 89-106.
- Kirrane, M., & Buckley, F. (2004). The influence of support relationships on work-family conflict: Differentiating emotional from instrumental support. *Equal Opportunities International, 23*, 78-96.
- Konovsky, M. A., & Pugh, S. D. (1994). Citizenship behavior and social exchange. *Academy of Management Journal, 37*, 656-669.
- Kossek, E. E., Noe, R., & DeMarr, B. (1999). Work-family role synthesis: Individual, family and organizational determinants. *International Journal of Conflict Resolution, 10*, 102-129.
- Loi, R., Yang, J., & Diefendorf, J. M. (2009). Four-factor justice and daily job satisfaction: A multi-level investigation. *Journal of Applied Psychology, 94*, 770-781.
- Madsen, S. R. (2006). Work and family conflict: Can home-based teleworking make a difference? *International Journal of Organization Theory and Behavior, 9*, 307-350.
- Moorman, R. H. (1991). The relationship between organizational justice and organizational citizenship behavior: Do fairness perceptions influence employee citizenship? *Journal of Applied Psychology, 76*, 845-855.
- Moorman, R. H., Blakely, G. L., & Niehoff, B. P. (1998). Does perceived organizational support mediate the relationship between procedural justice and organizational citizenship behavior? *Academy of Management Journal, 41*, 351-357.
- Niehoff, B. P., & Moorman, R. H. (1993). Justice as a mediator of the relationship between methods of monitoring and organizational citizenship behavior. *Academy of Management Journal, 36*, 527-556.
- Oplatka, I. (2006). Going beyond role expectations: Toward an understanding of the determinants and components of teacher organizational citizenship behavior. *Education Administration Quarterly, 42*, 385-423.
- Oplatka, I. (2009). Organizational citizenship behavior in teaching: The consequences for teachers, pupils and the school. *Journal of Educational Administration, 47*(1), 108-126.
- Organ, D. W. (1988). *Organizational citizenship behavior: The good soldier syndrome*. Lexington, MA: Lexington Books.
- Parasuraman, S., Purhoit, Y. S., Godshalk, V. M., & Beutell, N. J. (1996). Work and family variables, entrepreneurial career success, and psychological well-being. *Journal of Vocational Behavior, 48*, 275-300.
- Podsakoff, N. P., Whiting, S. W., Podsakoff, P. M., & Blume, B. D. (2009). Individual and organizational level consequences of organizational citizenship behaviors: A meta-analysis. *Journal of Applied Psychology, 94*(1), 122-141.
- Podsakoff, P. M., MacKenzie, S. B., Paine, J. B., & Bachrach, D. G. (2000). Organizational citizenship behaviors: A critical review of the theoretical and empirical literature and suggestions for future research. *Journal of Management, 26*, 513-563.
- Repetti, R. L. (1989). Effects of daily workload on subsequent behavior during marital interaction: The roles of social withdrawal and spouse support. *Journal of Personality and Social Psychology, 57*, 651-659.
- Tziner, A., & Dawis, R. (1988). Occupational stress: A theoretical look from the perspective of Work Adjustment Theory. *International Journal of Management, 5*, 423-430.
- Ullman, J. E. (2007). Structural Equation Modeling. In B. G. Tabachnick & L. S. Fidell, *Using Multivariate Statistics* (5<sup>th</sup> ed.). Boston, MA: Allyn and Bacon.