

Available online at [www.sciencedirect.com](http://www.sciencedirect.com)

SCIENCE @ DIRECT®

Vision Research 45 (2005) 2972–2985

Vision  
Research[www.elsevier.com/locate/visres](http://www.elsevier.com/locate/visres)

# Illusory rebound motion and the motion continuity heuristic

P.-J. Hsieh, G.P. Caplovitz, P.U. Tse \*

*Department of Psychological and Brain Sciences, Moore Hall, Dartmouth College, H.B. 6207, Hanover, NH 03755, USA*

Received 25 November 2004; received in revised form 22 February 2005

## Abstract

A new motion illusion, “illusory rebound motion” (IRM), is described. IRM is qualitatively similar to illusory line motion (ILM). ILM occurs when a bar is presented shortly after an initial stimulus such that the bar appears to move continuously away from the initial stimulus. IRM occurs when a second bar of a different color is presented at the same location as the first bar within a certain delay after ILM, making this second bar appear to move in the opposite direction relative to the preceding direction of ILM. Three plausible accounts of IRM are considered: a shifting attentional gradient model, a motion aftereffect (MAE) model, and a heuristic model. Results imply that IRM arises because of a heuristic about how objects move in the environment: In the absence of countervailing evidence, motion trajectories are assumed to continue away from the location where an object was last seen to move.

© 2005 Elsevier Ltd. All rights reserved.

*Keywords:* Illusory rebound motion; Illusory line motion; Attention; Motion after effect; Heuristic

## 1. Introduction

Motion perception evolved to convey accurate and useful information about changes in the world. A fundamental processing hurdle arises because any motion at the level of the retinal image is consistent with an infinite number of possible motions in the world. Because visual information permits us to interact adequately with our environment, it must be the case that the visual system has overcome this ambiguity. The visual system must at least implicitly make assumptions about the likelihoods of various possible correspondences between image motion and world motion. These “Bayesian priors” about the likelihoods of image-world motion correspondence constrain the interpretation of the inherently ambiguous sensory input, permitting the rapid construction of the motion that most likely happened in the

world. A shorthand way to describe such priors is to describe them in ordinary language as “heuristics”, even when it is acknowledged that their neuronal instantiation is likely to have little in common with such a high-level description. Examples of possible “heuristics” include the following: objects tend to travel along trajectories that are continuous; objects tend to change shape continuously; objects rarely appear out of nowhere; and objects rarely disappear into thin air.

The constructive and interpretive nature of perception is exemplified by stimuli in which visual input changes shape, position or motion trajectory in a discontinuous or discrete manner. Instead of perceiving a discrete change, which the input in fact undergoes, the visual system typically interpolates a continuous trajectory or change in object shape, such that the change is perceived as a smooth displacement or deformation. It is as if the visual system assumes that discrete inputs arise from changes that are in fact continuous in the world, and “corrects” sensory information in order to construct percepts about the most likely state of the world. This correction presumably leads to veridical

\* Corresponding author. Tel.: +1 603 646 4014.

E-mail addresses: [po-jang.hsieh@dartmouth.edu](mailto:po-jang.hsieh@dartmouth.edu) (P.-J. Hsieh), [gideon.caplovitz@dartmouth.edu](mailto:gideon.caplovitz@dartmouth.edu) (G.P. Caplovitz), [peter.u.tse@dartmouth.edu](mailto:peter.u.tse@dartmouth.edu), [peter.tse@dartmouth.edu](mailto:peter.tse@dartmouth.edu) (P.U. Tse).

perception in most cases, but can lead to illusions when, in fact, one is viewing discrete stimulus changes.

The phenomenon of apparently smooth and continuous shape change has been termed “transformational apparent motion” (TAM; Tse & Cavanagh, 1995). A precedent to TAM was first described by Kanizsa (1951, 1971), and termed “polarized gamma motion”. This phenomenon was rediscovered in a more compelling form by Hikosaka, Miyauchi, and Shimojo (1993a, 1993b). They showed that when a horizontal bar is presented shortly after an initial stimulus, the bar appears to shoot away from the initial stimulus. This phenomenon (Fig. 1(a)) has been termed “illusory line motion” (ILM). Hikosaka et al. hypothesized that the effect was due to the formation of an attentional gradient around the initial stimulus. In particular, they argued ILM could be explained by the principle of attentional “prior entry” (Titchener, 1908), which states that visual information near an attended locus is processed more quickly than information elsewhere. Because an attentional gradient presumably falls off with distance from the initial stimulus, and because it has been shown that attention increases the speed of stimulus detection (Stelmach & Herdman, 1991; Stelmach, Herdman, & McNeil, 1994; Sternberg & Knoll, 1973), they hypothesized that ILM occurs because of the asynchronous arrival of visual input to a motion detector such as human area V5. Several authors immediately argued that ILM is not due to this mechanism, but is actually an instance of apparent motion, not of object translations, but of object shape changes or deformations (Downing & Treisman, 1997; Tse & Cavanagh, 1995; Tse, Cavanagh, & Nakayama, 1996, 1998). These authors have shown that TAM arises even when attention is paid to the opposite end of the initial stimulus, implying that there must be other contributors to the motion percept than a gradient of attention. In particular, Tse and Logothetis (Tse & Logothetis, 2002) have shown that figural parsing plays an essential role in determining the direction of TAM. Figural parsing involves a comparison of contour relationships among successive scenes and takes place over 3D representations.

Here, we report a new illusion (Fig. 1(b)) that we call “illusory rebound motion” (IRM). When a bar of a different color replaces a bar over which ILM has just occurred, observers report that the bar appears to shoot in the opposite direction relative to the previous direction of ILM. Additionally, if bars of different colors are presented one after another at a constant stimulus onset asynchrony (SOA) following ILM, IRM can be perceived to occur over every bar with alternating direction, as if a “zipper” were opening and closing (Fig. 1(c)).

The purpose of this paper is twofold: First we describe the spatiotemporal dynamics of IRM (Experiments 1

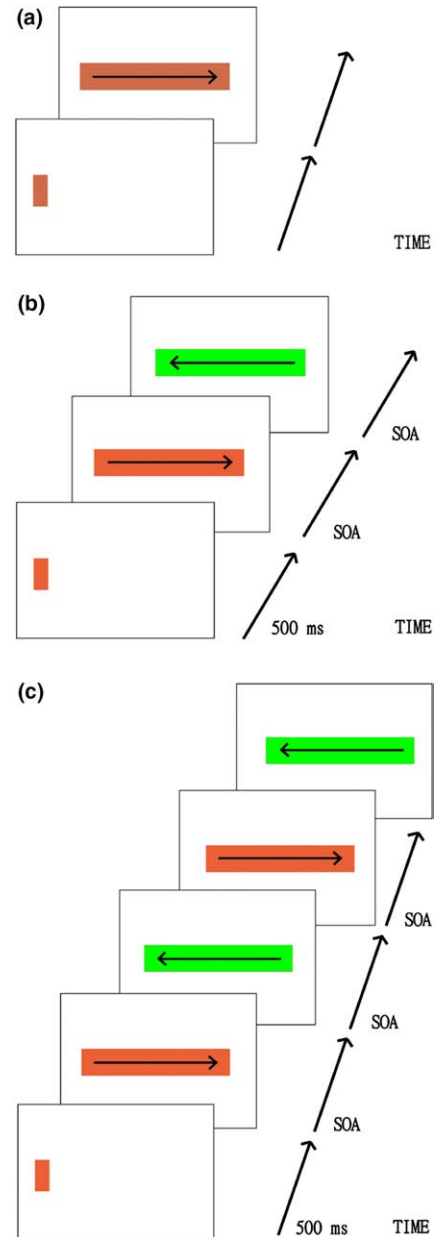

Fig. 1. (a) *Illusory line motion*: When a horizontal bar is presented shortly after an initial stimulus, the bar is perceived to shoot smoothly away from the initial stimulus. (b) *Illusory rebound motion*: When a second bar of a different color instantaneously replaces a bar over which ILM has just occurred, observers report that the bar appears to shoot smoothly in the opposite direction. (c) *Repeated IRM*: If bars of alternating colors are repeatedly presented after an ILM (one after another with a constant SOA), IRM can be perceived to occur over every bar with alternating direction. The arrows on the bars indicate the perceived motion direction. All bars are in fact presented all at once. Any perceived motion is illusory.

and 2). In particular, we describe the interaction between SOA and IRM. Second, we distinguish among three candidate models of IRM (Experiments 3–5): (1) a motion aftereffect hypothesis, (2) an attentional gradient hypothesis, and (3) a heuristic hypothesis. The results of Experiments 3 and 4 show that IRM can be induced

independently of an attention gradient. The results of Experiment 5 show that IRM is not compatible with either the motion aftereffect or attentional gradient hypotheses. Our data suggest that IRM may be governed by a new heuristic, according to which motion is assumed to recommence away from the location where it last ceased. This heuristic will be related to other heuristics that others have argued play a role in visual processing.

## 2. Experiment 1: The spatiotemporal dynamics of IRM

The goal of Experiment 1 was to determine the minimal stimulus duration necessary to generate IRM. We tested this by systematically varying the duration of the initial ILM-inducing bar that was displayed before the second IRM bar was displayed.

### 2.1. Method

#### 2.1.1. Observers

Twelve subjects (10 naïve Dartmouth undergraduates and two of the authors) with normal or corrected-to-normal vision carried out the experiment. All of them participated in practice trials composed of 5 min of single IRM (Fig. 1(b)) and 5 min of repeated IRM (Fig. 1(c)). The procedures of practice trials were the same as the procedures in Experiments 1 and 2. Those who reported that they could not see IRM (3/12) during the practice trials were excluded from participating further in the experiments. Therefore, nine subjects participated in this experiment.

#### 2.1.2. Stimulus displays

The fixation was a yellow (R: 255 G: 255 B: 0; luminance: 89.08 cd/m<sup>2</sup>) square that subtended 0.05° of visual angle on a black background (luminance: 1.68 cd/m<sup>2</sup>), and the initial stimulus was a red (R: 180 G: 77 B: 77; luminance: 31.45 cd/m<sup>2</sup>) square that subtended 1.05° in height and 0.45° in width. The first red bar and the target bar (green; R: 77 G: 230 B: 77; luminance: 80.51 cd/m<sup>2</sup>) subtended 1.05° in height and 7.37° in width.<sup>1</sup> The initial stimuli were presented 3.46° to either the left or the right of fixation, and the first bar and the target bar were all centered at the fixation point.

The visual stimulator was a 2 GHz Dell workstation running Windows 2000. The stimuli were presented on a 23-in SONY CRT monitor with 1600 × 1200 pixels resolution and 85 Hz frame rate. Observers viewed the stimuli from a distance of 76.2 cm with their chin in a chin rest. Fixation was ensured using a head-mounted

eyetracker (Eyelink2, SR research, Ont., Canada; Tse, Sheinberg, & Logothetis, 2002). Any time the subject's monitored left eye was outside a fixation window of 1.5° radius, the trial was automatically aborted, and a new trial was chosen at random from those remaining. The eyetracker was recalibrated when the subject's monitored eye remained for whatever reason outside the fixation window while the subject reported maintaining fixation. Once calibration was completed, the experiment resumed with a random trial.

#### 2.1.3. Procedure

The stimulus configuration used in Experiment 1 is shown in Fig. 1(b). Each trial began with a fixation point presented alone for approximately 500 ms (42 frames ≈ 494.12 ms; the frame rate = 85 Hz), after which a red initial stimulus was presented for 500 ms. A red bar (first bar) was presented after the initial stimulus for a duration randomly selected from the set (SOAs): 50 ms (4 frames ≈ 47.06 ms), 75 ms (6 frames ≈ 70.59 ms), 100 ms (8 frames ≈ 94.18 ms), 200 ms (17 frames), 300 ms (25 frames ≈ 294.18 ms), 400 ms (34 frames), or 500 ms. The practice trials indicated that at each of these durations the red bar was perceived to continuously extend away from the initial stimulus (ILM).

After the red bar was displayed, a target green bar (second bar) was presented. Observers had to indicate the direction of motion of the final bar presented (target bar) by pressing one of two buttons on a USB mouse (a two-alternative forced-choice task). The green bar remained present until the response triggered the next trial. There were two variables in this experiment: (1) The side on which the initial stimulus was presented, and (2) the seven SOAs that were tested. In this experiment, 25% of the trials were control trials. These were similar to test trials except that the target bars in the control trials were composed of "real motion". The test and control trials were randomly mixed across 240 presentations.

Real motion was created by presenting eight frames with a very short SOA between them (1 frame ≈ 11.76 ms). If the real motion was a leftward (rightward) motion, the first frame would contain a shortest bar centered 3.22° to the right (left) of fixation which subtended 1.05° in height and 0.92° in width. Each subsequent frame would contain a bar 0.92° longer than the bar in the previous frame, and centered 0.46° more to the left (right) of the bar in the previous frame. In half of the control trials, the target bar had the same direction of motion as the previous ILM. In the other half of the control trials, the target bar had the opposite direction of motion direction as the previous ILM. Though the control/real motion was perceptually distinguishable from ILM, the basic idea of using control/real motion was to (1) create confidence that observers reported their perceived motion correctly, and (2) counter-

<sup>1</sup> For interpretation of color in figures, the reader is referred to the web version of this article.

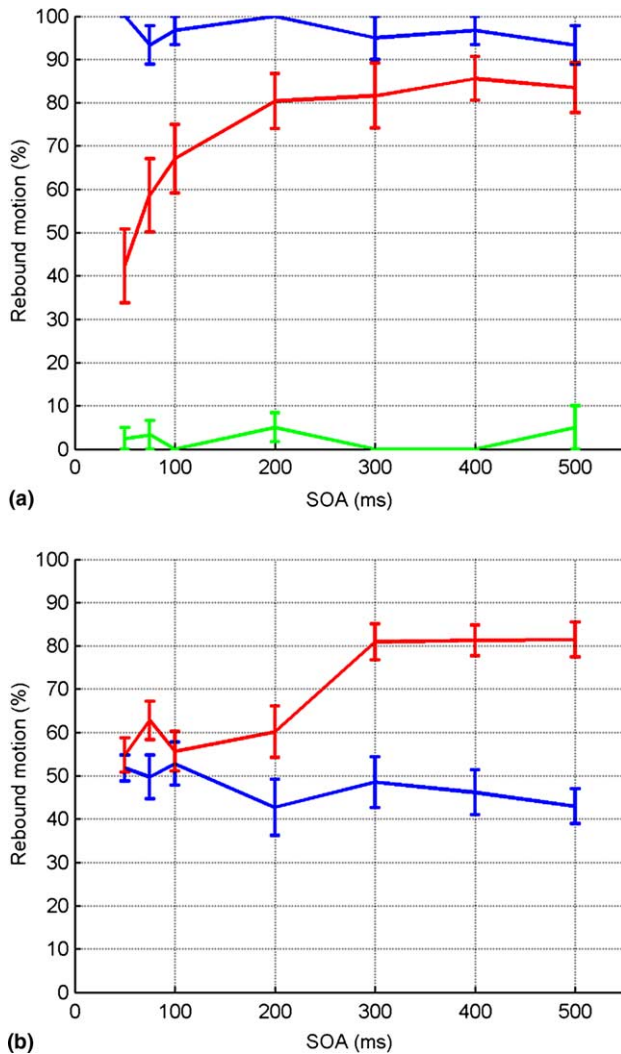

Fig. 2. (a) *Timecourse of IRM*. The red curve ( $n = 9$ ) shows that the percentage of IRM is 50% (chance rate) at the shortest SOA tested (50 ms), and increases quickly as a function of SOA. The rebound motion was perceived 80% at about 200 ms, and was still perceived at this high level at the longest SOA tested (500 ms). The blue curve shows that, in control trials containing a “real rebound motion” (see Methods), the percentage of trials on which IRM was perceived was always high (>90%) with respect to any SOA. The green curve shows that, in control trials that contained a “real same-way motion” (see Methods) in the same direction as the prior ILM, the percentage of trials on which IRM was perceived was consistently low (<10%) with respect to any SOA. (b) *Timecourse of repeated IRM*. The red curve ( $n = 15$ ) shows that the percentage of IRM reported, which was consistent with a back and forth motion commencing from the initial stimulus, was about 50% (chance rate) at the shortest SOAs tested (50 ms). The rebound motion was perceived for 80% of the trials shown at about 300 ms, and was still perceived at this high rate at the longest SOAs tested (500 ms). The data demonstrate that there is a minimum SOA for repeated IRM to be observed (300 ms), the blue curve shows that in control trials, where no initial stimulus was presented to initiate ILM or IRM, the percentage of IRM reported that was consistent with a continuous back and forth motion was always at a chance rate (50%) with respect to any SOA.

balance the amount of rebound motion and same-way motion to keep subjects from always anticipating and therefore seeing only one kind of motion.

## 2.2. Results

The results are shown in Fig. 2(a), where the percentage of perceived IRM is plotted against SOA. The percentage of perceived IRM is about 50% (chance rate) at the shortest SOA tested (50 ms), and increases quickly as a function of SOA. The perception of IRM asymptotes to 80% starting at about 200 ms, and can still be perceived at this high level at the longest SOA tested (500 ms).

## 2.3. Discussion

The data suggest that there is a minimum SOA necessary for the perception of IRM. At the shortest SOA, subjects report rebound motion at the 50% chance rate. A possible reason why IRM cannot be seen at the shortest SOA (50 ms) may be that the visual motion processing system may have to sample information for a minimal duration (>100 ms) before being able to assign motion to the target bar. It is also possible that when SOA is short (50 ms), the target bar acts as a mask so that the ILM presented before the target bar becomes less visible. Because the ILM is less visible, the likelihood of seeing IRM may be lower. The data also indicates that the perception of IRM persists even at the longest SOA tested. An outstanding question is how long of an SOA is necessary for the percept to fade?

## 3. Experiment 2: Repeated IRM

In Experiment 2, we tested the effects of various delays (SOAs) on the perceived strength (duration and percentage) of IRM by repeatedly presenting bars after an ILM at a given SOA.

### 3.1. Method

#### 3.1.1. Observers

Eighteen Dartmouth undergraduates with normal or corrected-to-normal vision were paid to carry out the experiment. Twelve of them were naïve about ILM and IRM, and six of them had participated in Experiment 1. All of the 12 naïve subjects had participated in practice trials as described above. Those who reported that they could not see ILM (3/12) during the practice trials were excluded from participating further in the experiments. Therefore, 15 subjects participated in this experiment.

#### 3.1.2. Stimulus displays

The procedures of Experiment 2 are shown in Fig 1(c). All the stimuli and procedures are similar to those of Experiment 1 except that, instead of one bar, multiple bars of different colors (alternating between red and green) were presented one after another at a constant SOA following ILM (Fig. 1(c)).

### 3.1.3. Procedure

The stimulus configuration used in Experiment 2 is shown in Fig 1(c). Each trial began with a fixation point presented alone for 500 ms, after which an initial stimulus (red or green) was presented for 500 ms. A bar (the first bar), with the same color as the initial stimulus, was presented after the initial stimulus following a randomized time delay (SOAs): 50, 75, 100, 200, 300, 400 or 500 ms to create ILM. After that, the second bar, with a different color, was presented for the same duration of time as the first bar. A variable number of subsequent bars were presented one after another with alternating color, for the same duration of time as the first bar. The last bar (target bar) was presented and continuously displayed until a button press response triggered the next trial. There were four variables in this experiment: (1) The initial stimulus could appear on the left or right side. (2) The initial stimulus could be either red or green. (3) The number of successive bars presented was either seven or eight so that the final bar could be either red or green in a manner not predictable by the color or location of the initial stimulus. (4) There were seven possible stimulus onset asynchronies (SOAs). Twenty-five percent of the trials were control trials. These were similar to test trials except that there was no initial stimulus at the beginning of a control trial. Test and control trials were randomly mixed across 210 presentations. Observers were required to indicate the last direction (rightward or leftward) of IRM perceived over the last bar (target bar) by pressing one of two buttons on a USB mouse (a two-alternative forced-choice task).

### 3.2. Results

Results are shown in Fig. 2(b) where the percentage of perceived IRM is plotted against SOA. The percentage of IRM reported, which was consistent with a back and forth motion that commenced at the initial stimulus, was about 50% (chance rate) at shorter SOAs (50, 75, 100, and 200 ms). The perception of IRM asymptotes to 80% starting at about 300 ms, and can still be perceived at this high level at the longest SOA tested (500 ms).

### 3.3. Discussion

Though the timecourses are similar in Experiments 1 and 2, IRM could be seen at a shorter SOA (200 ms) in Experiment 1 than in Experiment 2 (300 ms). The main difference between Experiments 1 and 2 was that only one new bar was presented after ILM in Experiment 1, whereas several were presented after ILM in Experiment 2. Multiple bar presentations at a fast rate (SOA < 300 ms) in Experiment 2 may have made the judgment of final motion direction more difficult because more bar alternations would provide more time

for distraction or losing track of the illusory motion signal, accounting for the difference between the results of the two experiments.

Our data also suggest that the occurrence and location of the initial stimulus have long-term effects on motion perception. Because there were always either seven or eight bars presented in succession after presentation of the initial stimulus, for the longest SOA tested, the data imply that IRM was perceived for up to 4 s after initial stimulus onset. Longer durations were not tested, but informal observations indicate that IRM can continue for much longer even than this and is difficult to extinguish. This is true even when effort is made to see the stimulus veridically, namely, as a succession of bars with no real motion.

## 4. Experiment 3: Attention is not drawn to the end of the ILM at a long SOA

One possible explanation for IRM would be the attentional gradient hypothesis (Hikosaka et al., 1993a, 1993b), which had been originally proposed to explain ILM. According to this account, a gradient of attention centered at the initial stimulus may speed up the processing of stimuli presented closer to the initial stimulus. This model cannot explain IRM because the gradient of attention is assumed to be centered on the location of the initial stimulus, and in Experiment 1, the IRM is observed towards this location. However, a modified gradient model can perhaps account for IRM. For example, if attention can be drawn to the end of the ILM and then build up a new attentional gradient there, the same mechanism may operate over the second and subsequent bars to induce the illusory percept of motion. Any information presented closer to the new attentional gradient's center would be processed more quickly by a motion detection mechanism and would become conscious faster.

Therefore, in Experiment 3, we directly measured whether attention is drawn to the end of ILM by measuring reaction time, in order to further constrain theories of the mechanisms underlying ILM and IRM. If the IRM observed after an ILM, is really caused by a stronger attentional gradient located at the end of the ILM, as the attentional gradient hypothesis would suggest, then we should be able to detect some attentionally induced benefit immediately following ILM. One such observable benefit should be a faster reaction time (Carrasco & Yeshurun, 1998; Posner, 1980; Yeshurun & Carrasco, 1999) at one end of the bar relative to the other. Additionally, if an attentional gradient is the cause of the IRM percept then the timecourse of IRM and the timecourse of any measured attentional benefits should be similar. For example, the hypothesis predicts that at a short (~50 ms) SOA the attentional benefit,

similar to the likelihood of perceived IRM, will be low, and the attentional benefit will be high at a long (~500 ms) SOA, where the IRM percept is strong.

4.1. Method

4.1.1. Observers

Nine subjects (seven paid Dartmouth undergraduates and two of the authors) with normal or corrected-to-normal vision carried out the experiment. Five of them had participated in Experiment 2, and four of them were naïve about the ILM and IRM.

4.1.2. Stimulus displays

The fixation was a yellow square that subtended 0.05° of visual angle on a black background. The initial stimulus was a green square (R: 77 G: 180 B: 77; luminance 65.44 cd/m<sup>2</sup>), presented 3.46° to either the left or the right of fixation, which subtended 1.05° in height and 0.45° in width. The green bar that was presented after the initial stimulus to create ILM was centered at the fixation point and subtended 1.05° in height and 7.37° in width. The target was a red square, presented 3.46° to either the left or the right of fixation, which subtended 0.3° in height and 0.3° in width.

4.1.3. Procedure

Each trial began with a fixation point presented alone for 1000 ms (85 frames), after which a green initial stimulus was presented for 500 ms. A green bar was presented after the initial stimulus for a given time delay (stimulus onset asynchronies; 50 ms, 500 ms, 900 ms (76 frames ≈ 894.12 ms); separated blocks) to create ILM, after which a red target square was presented and continuously displayed until the response triggered the next trial. The side of the initial stimulus (left or right) and the target side (left or right) were counterbalanced and randomly mixed across 240 trials in each block. In the “test” trials, a red target square was presented at the end of illusory motion. In the “control” trials, a red target square was presented at the opposite end of ILM (i.e., where the initial stimulus had appeared). Observers had to indicate the location (left or right of the green bar) of the target square by pressing one of two buttons on a USB mouse as fast and accurately as they could.

4.2. Results

The results are shown in Fig. 3. The left column shows that when SOA is short (50 ms), test trials had a lower error rate and faster reaction time. The attentional benefit, calculated by subtracting the reaction time in test trials from control trials, is about 35 ms (Fig. 3, left lower). The middle and right columns show that when SOA is long (500 and 900 ms), test trials and control trials had a similar error rate and reaction time.

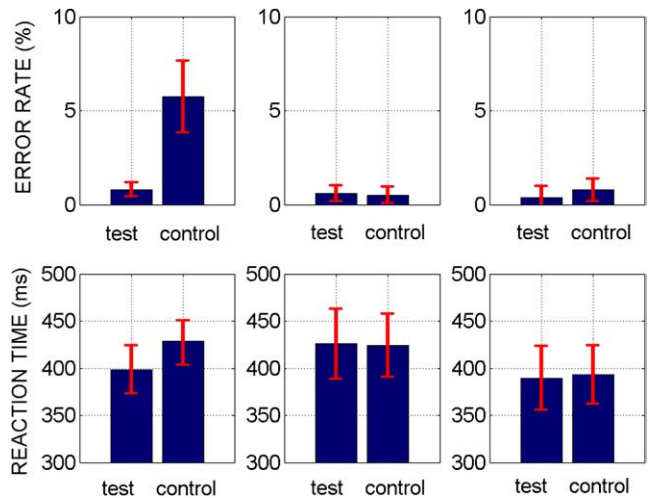

Fig. 3. Results of Experiment 4. The left column shows that when SOA is short (50 ms), test trials had a lower error rate and faster reaction time. The attentional benefit, calculated by subtracting the reaction time in test trials from control trials, is about 35 ms (left lower). The middle and right columns show that when SOA is long (500 and 900 ms), test trials and control trials had a similar error rate and reaction time. There is no significant attentional benefit for long SOAs (middle lower and right lower).

There was no significant attentional benefit for long SOAs (Fig. 3, middle lower and right lower).

4.3. Discussion

The timecourse of the attentional benefit, shown in Fig. 4 by plotting attentional benefits against SOA, re-

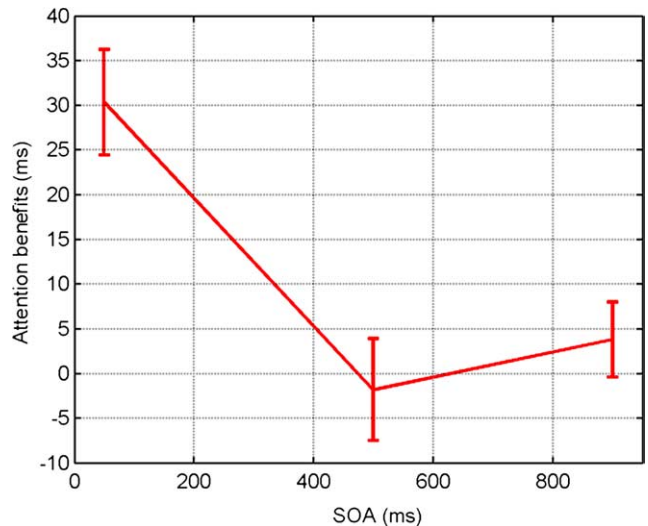

Fig. 4. Attention benefit fades as the SOA increases. When comparing the timecourse of the attentional benefit to that of IRM (Fig. 2(a)), it is obvious they are very different timecourses. At the short SOA (50 ms) tested, the attentional benefit is high, but the percentage of perceived IRM is low. At long SOAs (500 or 900 ms), the attentional benefit is low, but the percentage of perceived IRM is high. Therefore IRM is not likely to be caused by an attentional mechanism.

veals that the attentional benefit decreases as the SOA increases. When compared to the timecourse of IRM in Fig. 2(b), it is obvious that the attentional benefit and IRM have radically different timecourses, suggesting that they arise for different reasons. At the shortest SOA (50 ms) tested, the attentional benefit is high, but the percentage of perceived IRM is low. At longer SOAs (500 or 900 ms), the attentional benefit is low, but the percentage of perceived IRM is high. Thus the predictions made by the attentional gradient hypothesis are not observed in the empirical data.

## 5. Experiment 4: Attention gradients do not cause IRM

Though the timecourse of the attentional benefit and that of IRM are different, some might still want to argue that this does not rule out the possibility of the attentional gradient hypothesis because reaction times might not be a good criterion for measuring attention. Experiment 4 was conducted to find out whether or not attention may follow the ILM and IRM at an SOA of up to 500 ms using another measure of attention: contrast sensitivity. In Experiment 4a, we replicated Carrasco et al.'s experiment (Carrasco, Ling, & Read, 2004) showing that contrast sensitivity can be enhanced by attention. In Experiment 4b, we replaced the cue (dot) with ILM to test whether contrast sensitivity is enhanced at the end of ILM. In Experiments 4c and 4d, we replaced the cue (dot) with IRM to test whether contrast sensitivity is enhanced at the end of IRM. If attention is drawn to the end of the ILM or IRM, contrast sensitivity at that location should be increased.

### 5.1. Method

#### 5.1.1. Observers

Ten subjects (nine paid Dartmouth undergraduates and one of the authors) with normal or corrected-to-normal vision participated in Experiments 4a and 4b. Five of them had participated in Experiment 2, and five of them were naïve about the ILM and IRM.

Sixteen subjects (15 paid Dartmouth undergraduates and one of the authors) with normal or corrected-to-normal vision carried out Experiments 4c and 4d. Five of them had participated in Experiment 2, and 11 of them were naïve about the ILM and IRM.

Ten subjects (paid Dartmouth undergraduates) with normal or corrected-to-normal vision carried out Experiments 4e and 4f. All of them were naïve about the ILM and IRM.

#### 5.1.2. Stimulus displays

In Experiment 4a, the fixation was a yellow square that subtended  $0.05^\circ$  of visual angle on a gray (R: 128 G: 128 B: 128; luminance  $44.37 \text{ cd/m}^2$ ) background.

The cue was a black square (luminance  $1.68 \text{ cd/m}^2$ ) that subtended  $0.2^\circ$  in height and  $0.2^\circ$  in width, which was presented  $2.5^\circ$  to the left of fixation, or  $2.5^\circ$  to the right of fixation, or centered at fixation. The targets were two horizontal sinewave gratings ( $3.7 \text{ cycles/deg}$ ). The mean luminance of sinewave gratings was equivalent to that of the background. Both subtended  $2.7^\circ$  in height and  $2.7^\circ$  in width. They were presented separately, one centered  $5.1^\circ$  to the left and the other centered  $5.1^\circ$  to the right of fixation. The contrast of the standard target sinewave grating was always 1%, and the contrast of the test target sinewave grating was chosen from a randomized list (0.25%, 0.5%, 1%, 1.5%, 1.75%).

In Experiment 4b, all stimuli were the same as in Experiment 4a, except that the cue was replaced by an ILM. The ILM was created by first presenting a green square subtending  $1.05^\circ$  in height and  $0.45^\circ$  in width, which was followed by a green bar subtending  $1.05^\circ$  in height and  $7.37^\circ$  in width. The square was presented  $3.46^\circ$  to either the left or the right of fixation, and the bar was centered at the fixation point.

In Experiment 4c, all stimuli were the same as in Experiment 4a, except that the cue was replaced by a single-rebound IRM. The IRM was created by first presenting a green square subtending  $1.05^\circ$  in height and  $0.45^\circ$  in width, which was followed by a green bar subtending  $1.05^\circ$  in height and  $7.37^\circ$  in width, and then followed by another red bar subtending  $1.05^\circ$  in height and  $7.37^\circ$  in width. The square was presented  $3.46^\circ$  to either the left or the right of fixation, and the bars were centered at the fixation point.

In Experiment 4d, all stimuli were the same as in Experiment 4c, except that the cue was replaced by a twice-rebound IRM. The IRM was created by first presenting a green square subtending  $1.05^\circ$  in height and  $0.45^\circ$  in width, followed by a green bar. It is then followed by another red bar, and then followed by another green bar. All the green and red bars subtend  $1.05^\circ$  in height and  $7.37^\circ$  in width. The square was presented  $3.46^\circ$  to either the left or the right of fixation, and the bars were centered at the fixation point.

#### 5.1.3. Procedure

Fig. 5 depicts the stimulus timecourses for a single trial in Experiments 4a–4d. In Experiment 4a, each trial began with a fixation point presented alone for 1000 ms, after which a cue was presented for 70 ms (6 frames  $\approx 70.59 \text{ ms}$ ). After a given time delay (inter stimulus interval; 70 ms, 500 ms; separated blocks), two sinewave gratings were presented for 70 ms and then disappeared (switching on and off abruptly). One of the sinewave gratings was the “control” sinewave grating, which was fixed at 1% contrast. The other sinewave grating was the “test” target sinewave grating, which was chosen from a randomized list of contrasts (0.25%, 0.5%, 1%, 1.5%, 1.75%). The mean luminance

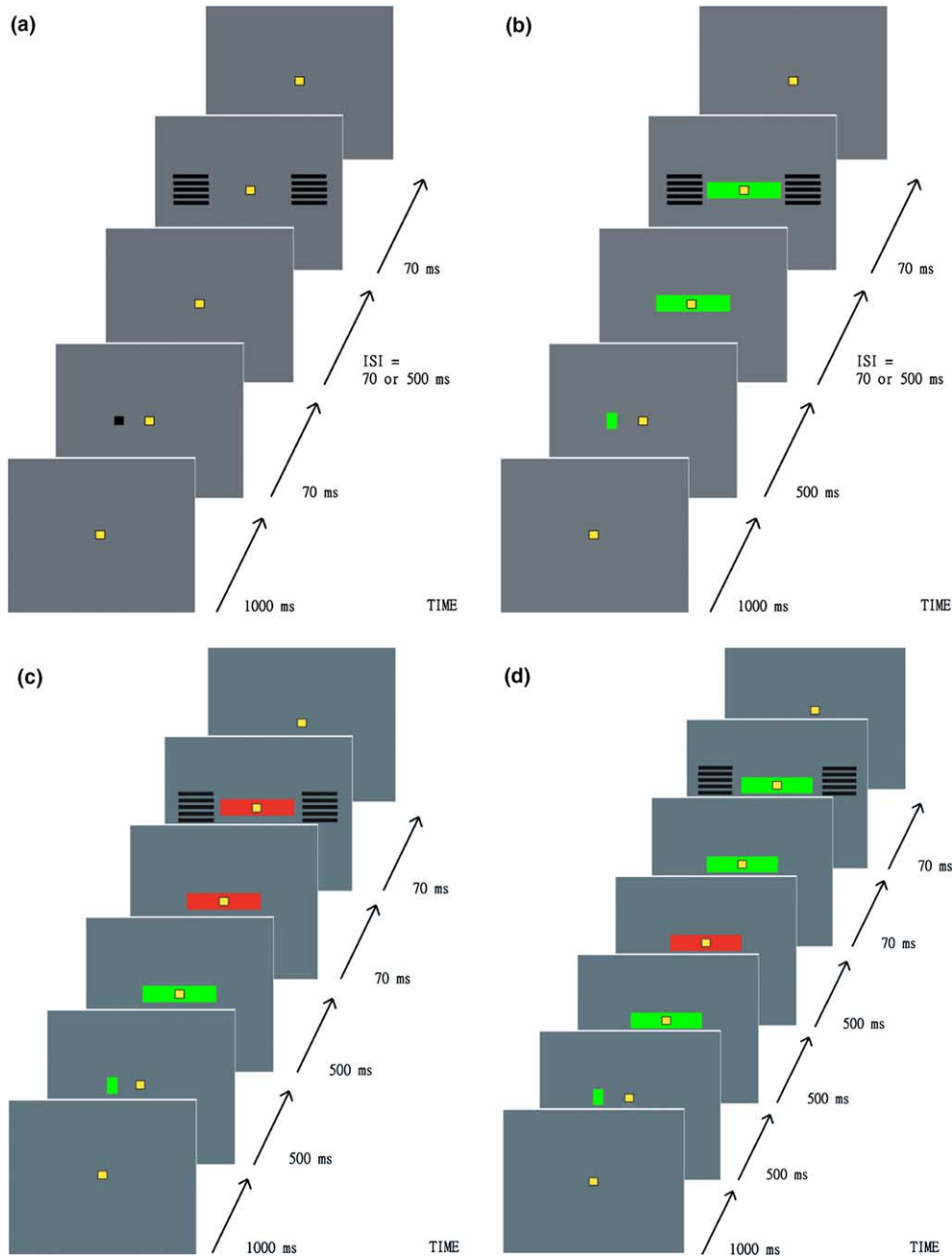

Fig. 5. Example trials of Experiments 4a and 4b: (a) In Experiment 4a, each trial began with a fixation point presented alone for 1000 ms, after which a cue was presented for 70 ms. After a given time delay (inter stimulus interval; 70 ms, 500 ms; separated blocks), two target sinewave gratings were presented for 70 ms and then disappeared. (b) In Experiment 4b, each trial began with a fixation point presented alone for 1000 ms, after which a square was presented for 500 ms. A bar was presented after the initial stimulus to create ILM and remained present. After a given time delay (stimulus onset asynchronies; 70 or 500 ms; separated blocks), two target sinewave gratings were presented for 70 ms and then disappeared together with the bar. (c) In Experiment 4c, each trial began with a fixation point presented alone for 1000 ms, after which a green square was presented for 500 ms. A green bar was presented after the initial stimulus for 500 ms to create ILM, after which another red bar was presented to create single-rebound IRM. After a given time delay (stimulus onset asynchronies; 70 ms), two target sinewave gratings were presented for 70 ms and then disappeared together with the bar. (d) In Experiment 4d, each trial began with a fixation point presented alone for 1000 ms, after which a green square was presented for 500 ms. A green bar was presented after the initial stimulus for 500 ms to create ILM, after which another red bar was presented for 500 ms and then followed by another green bar to create twice-rebound IRM. After a given time delay (stimulus onset asynchronies; 70 ms), two target sinewave gratings were presented for 70 ms and then disappeared together with the bar.

of sinewave gratings was equivalent to that of the back-ground. Observers had to indicate the location of the sinewave grating that appeared to have higher contrast

by pressing one of two buttons on a USB mouse (a two-alternative forced-choice task). The screen remained gray until the response triggered the next trial.



To avoid response bias, cued side (left or right) and test target side (left or right) were counterbalanced and randomly mixed across 240 trials in each block.

In Experiment 4b, the stimuli and procedures are similar to Experiment 4a, except that the cue in Experiment 4a is replaced with ILM. In this experiment, each trial began with a fixation point presented alone for 1000 ms, after which an initial stimulus was presented for 300 ms. A bar was presented after the initial stimulus to create ILM and remained present. After a given time delay (stimulus onset asynchronies; 70 or 500 ms; separated blocks), two target sinewave grating were presented for 70 ms (6 frames  $\approx$  70.59 ms) and then disappeared together with the bar. The screen remained gray until the response triggered the next trial. The direction of ILM (to the left or right) and test target side (left or right) were counterbalanced and randomly mixed across 240 trials in each block. Observers had to indicate the location of the sinewave grating that appeared to have higher contrast by pressing one of two buttons on a USB mouse (a two-alternative forced-choice task).

In Experiment 4c, the cue was replaced with single-rebound IRM (one rebound). Each trial began with a fixation point presented alone for 1000 ms, after which an initial stimulus (green square) was presented for 300 ms. A green bar was presented after the initial stimulus for 500 ms to create ILM, after which another red bar was presented to create single-rebound IRM. After a given time delay (stimulus onset asynchronies; 70 ms), two target sinewave gratings were presented for 70 ms and then disappeared together with the bar.

In Experiment 4d, the cue was replaced with twice-rebound IRM. Each trial began with a fixation point presented alone for 1000 ms, after which an initial stimulus (green square) was presented for 500 ms. A green bar was presented after the initial stimulus for 300 ms to create ILM, after which another red bar was presented for 500 ms and then followed by another green bar to create twice-rebound IRM. After a given time delay (stimulus onset asynchronies; 70 ms), two target sinewave gratings were presented for 70 ms and then disappeared together with the bar.

## 5.2. Results

The results of Experiment 4a are shown in Fig. 6(a) and (b). The percentage of trials where observers reported seeing the test sinewave grating as having higher contrast than the control is plotted as a function of the test sinewave grating's contrast. The results of Experiment 4a confirmed the previous findings of Carrasco et al. (2004) and showed that cueing a test sinewave grating enhanced its perceived contrast only at a short ISI (70 ms), but not at a long ISI (500 ms). For example, at a short ISI (70 ms), the percentage reporting greater contrast for the test sinewave grating (1%) was 65%

when the cue was presented before the test sinewave grating (blue curve, Fig. 6(a)); the percentage reporting greater contrast for the test sinewave grating (1%) was 50% when the cue was neutral (black curve, Fig. 6(a)); and the percentage reporting greater contrast for the test sinewave grating (1%) was 35% when the cue was presented before the control sinewave grating (red curve, Fig. 6(a)). In other words, the percentage reporting greater contrast for the test sinewave grating (1%) was enhanced by 15% when the cue was presented before the test sinewave grating. However, when the ISI was long (500 ms), this enhanced contrast effect disappeared (blue curve, Fig. 6(b)).

As shown in Carrasco et al. (2004, Fig. 6), response bias cannot account for their results, and by extension cannot account for ours. In that experiment, all stimulus parameters remain unchanged, but subjects now had to respond to the dimmer of two targets rather than the brighter of two objects after attentional cuing. The results under either set of instructions were identical, establishing that response bias does not account for attention-induced contrast sensitivity enhancement.

The results of Experiment 4b are shown in Fig. 6(c) and (d). Similar enhanced contrast effect was observed at a short SOA (70 ms). However, the effect is weaker. The percentage reporting greater contrast for the test sinewave grating (1%) was enhanced by <10% (blue curve, Fig. 6(c)). When the SOA was long (500 ms), the enhanced contrast effect disappeared (blue curve, Fig. 6(d)). The results of Experiments 4c and 4d are shown in Fig. 6(e) and (f), which show no enhanced contrast effects.

## 5.3. Discussion

In summary, the results of Experiment 4a imply that when cueing with a dot, using a short ISI, attention is drawn to the cued location because the subsequently presented sinewave grating is perceived to have relatively elevated contrast. However, when the ISI is longer (500 ms), the attentional benefit indicated by contrast enhancement disappeared. Similar results were observed in Experiment 4b by using ILM itself as a cue to measure potential benefits of attention. This implies that attention is drawn to the end of ILM when the SOA is short, but not when the SOA is long (500 ms). Additionally, the attentional benefit decreases as the SOA increases, in accordance with Experiment 3. These results are therefore inconsistent with the fact that the percentage of trials where IRM is perceived increases as the SOA increases. Furthermore, Experiments 4c and 4d showed that contrast sensitivity is not enhanced at the end of the IRM, which means that attention is not following IRM, and there is no attentional gradient at the end of IRM. All together, they suggest that IRM is not caused by an attentional gradient.

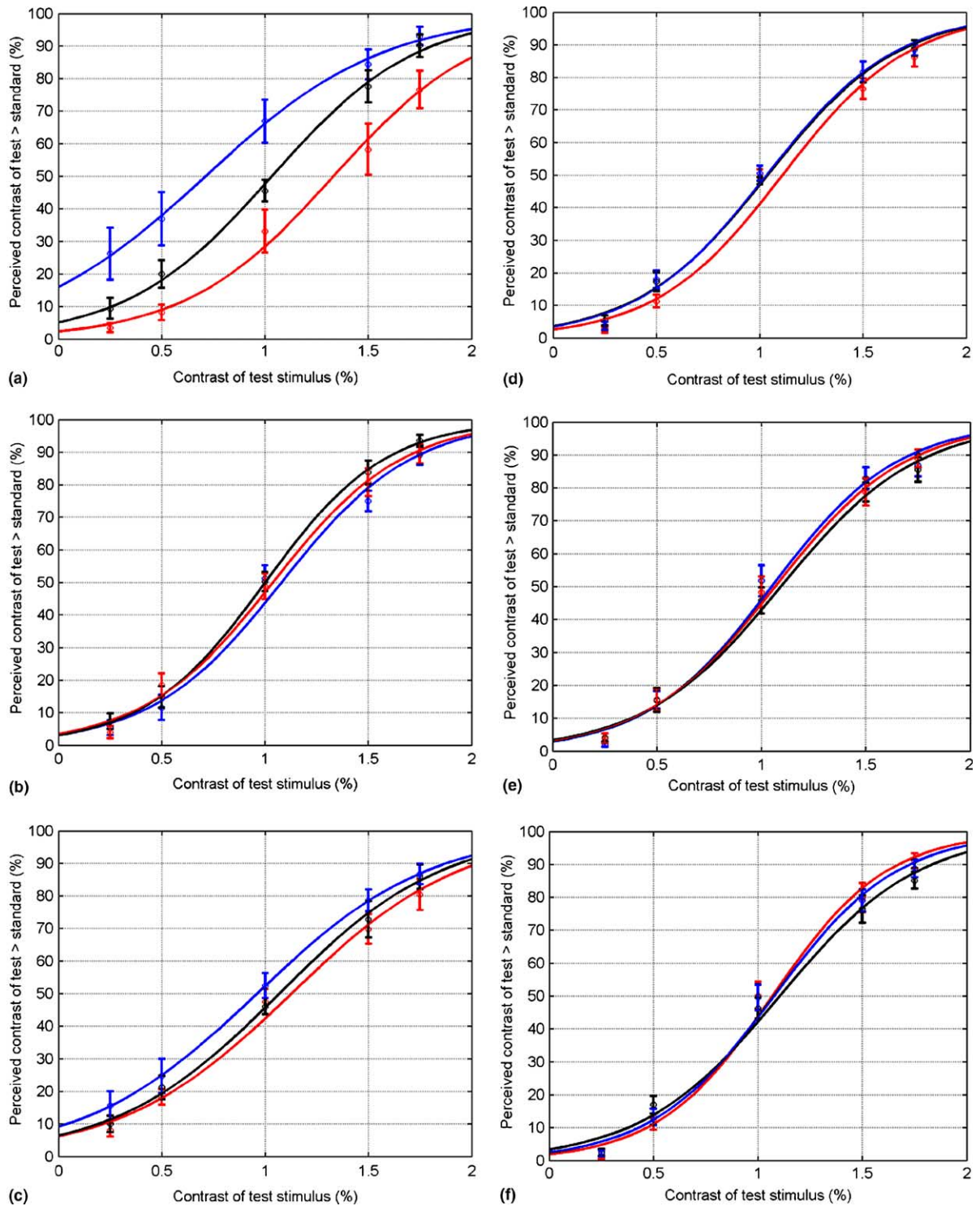

Fig. 6. Results of Experiment 4. Percentage of trials where observers reported the test sinewave grating to have higher contrast than the standard is plotted as a function of the test sinewave grating's contrast. The blue curve in every plot shows the percentage of trials where observers reported that the test sinewave grating had higher contrast than the standard when the test sinewave grating was cued. The red curve in every plot shows the percentage of trials where observers reported that the test sinewave grating had lower contrast than the standard when the standard was cued. The black curve shows the percentage of trials where observers reported that the test sinewave grating had higher contrast than the standard when the cue was at the fixation spot. In Experiment 4a, when the ISI was 70 ms (a), the leftward shifting of the blue curve reveals that cueing a test sinewave grating enhanced its perceived contrast, and the rightward shifting of the red curve reveals that cueing a standard sinewave grating lowered the perceived contrast of the test wave in relative terms; when the ISI is long (500 ms), the enhancement of perceived contrast disappeared (b). The results of Experiment 4B showed similar, but weaker effects ((c) and (d)). The results of Experiments 4c and 4d showed no effects ((e) and (f)).

To conclude, these results effectively eliminate either the traditional or modified versions of the attentional gradient hypothesis from contention as explanations of IRM or ILM. Since IRM could be perceived after ILM without the formation of an attentional gradient, IRM as well as ILM must be governed by some other mechanism than that posited by the attentional gradient hypothesis.

## 6. Experiment 5: MAE hypothesis vs. heuristic hypothesis

Experiments 3 and 4 eliminated the attentional gradient hypothesis from contention as a possible explanation of IRM or ILM. In Experiment 5 two other plausible hypotheses are considered and experimentally pitted against one another. These two hypotheses are

1. *the motion aftereffect hypothesis* suggests that IRM might be induced by neuronal adaptation caused by a previously perceived motion. The motion aftereffect (MAE), also called the “waterfall illusion”, refers to the illusory motion perceived on a stationary object or image following prolonged exposure to visual motion (Wohlgemuth, 1911). This phenomenon has been attributed to adaptation of directionally sensitive neuronal filters. Though it has never been shown that a MAE can be observed after exposure to any transient motion (real or illusory), such as ILM, it is still conceivable that IRM is due to a kind of MAE. If so, this aftereffect would have to be extremely fast-acting, because IRM is perceived at SOAs as short as 200 ms;
2. *the heuristic hypothesis*: a second plausible hypothesis is that the visual system interprets objects as moving away from where they last stopped moving, in the absence of image evidence suggesting otherwise. Such a heuristic would have ecological validity. For example, when an animal appears to move after having stopped, or after having momentarily blended with the background due to camouflage, it would be ecologically valid to see that animal move away from the location where it was last seen moving, all else being equal.

In Experiment 5 we pitted these conflicting hypotheses against one another. An example trial is shown in Fig. 7. The four cues moved smoothly and at a constant velocity to the location of their clockwise or anti-clockwise neighboring corner. After that, a green bar (target bar) was presented all at once, either above or below the fixation on the top or bottom side of the imaginary square defined by these cue locations, and remained present until the response triggered the next trial. Subjects were asked to indicate the perceived direction of target bar motion.

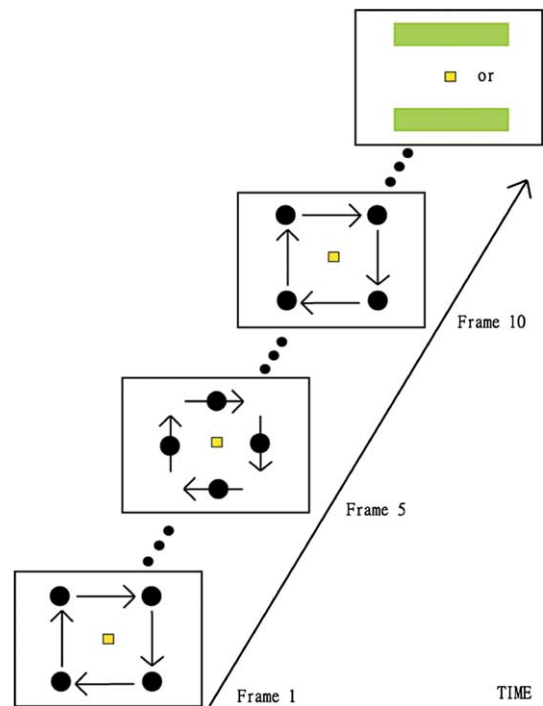

Fig. 7. An example trial of Experiment 5. In a given trial, the motion of the cues was created by presenting 10 frames with a short SOA (10 ms) between each of them. The four cues moved smoothly and at a constant velocity to the location of their clockwise or anti-clockwise neighboring corner. The 10th frame was presented for a randomized time delay (SOAs): 50 ms (4 frames  $\approx$  47.06 ms), 75 ms (6 frames  $\approx$  70.59 ms), 100 ms (8 frames  $\approx$  94.18 ms), 200 ms (17 frames), 300 ms (25 frames  $\approx$  294.18 ms), 400 ms (34 frames), or 500 ms (42 frames  $\approx$  494.12 ms). After that, a green bar (target bar) was presented all at once, either above or below the fixation on the top or bottom side of the imaginary square defined by these cue locations, and remained present until the response triggered the next trial. Arrows indicate the motion of the cues perceived by observers.

The two hypotheses make conflicting predictions about how a subject will perceive a target bar. The MAE hypothesis predicts that there will be IRM in the direction opposite that given by the cue motion, because the target bar is presented immediately after the cue's motion. Since the MAE hypothesis suggests that IRM can be induced after exposure to a transient illusory motion such as ILM, it should also predict that IRM can be induced after exposure to a transient real motion such as the cue motion in this experiment, especially since it has been shown that ILM is an instance of apparent motion (Tse, Cavanagh, & Nakayama, 1998; Tse & Logothetis, 2002).

Depending on the nature of the heuristic, the heuristic hypothesis either predicts that there will not be a net favored direction for IRM or that there will be. If the heuristic is simply that motion proceeds away from the location of the most recent cessation of object motion, then the heuristic hypothesis, like the attention hypothesis, predicts that there should not be a net favored

direction for IRM across all counterbalanced trials, because the four cues stop moving at the same time at each of the four corners. Since four motion offsets appear at four corners at the same time, there should be no preference to see motion in either the leftward or rightward directions on the next target bar. We can call this heuristic the “Location continuity heuristic”. However, if the heuristic is instead one according to which object motion continues not only away from the location where it left off, but also in a direction most similar to the direction that it last had, then the heuristic hypothesis would predict motion that proceeds in the same direction, either clockwise or anti-clockwise, as the cues themselves had undergone. This version we can call the “Trajectory continuity heuristic”.

## 6.1. Method

### 6.1.1. Observers

Seven subjects (five paid Dartmouth undergraduates and two of the authors) with normal or corrected-to-normal vision carried out the experiment. Six of them had participated in Experiment 2, and one of them was naïve about the ILM and IRM effects.

### 6.1.2. Stimulus and displays

The fixation point was a yellow square that subtended  $0.05^\circ$  of visual angle on a black background. The cues were four white (R: 255 G: 255 B: 255; luminance  $40.41 \text{ cd/m}^2$ ) dots with a  $0.25^\circ$  radius located separately at four corners, centered  $3.16^\circ$  (left or right) and  $3.16^\circ$  (up or down) relative to the location of the fixation point. The target bar was a green bar that subtended  $1.05^\circ$  in height and  $7.37^\circ$  in width, and that was centered either  $3.16^\circ$  above or below the fixation point.

### 6.1.3. Procedure

Fig. 7 depicts the timecourse of a single trial in this experiment. Each trial began with a fixation point that was presented alone for 500 ms, after which four white dots were presented as if they were moving smoothly and at a constant speed ( $0.0597 \text{ deg/ms}$ ) along the straight trajectories from their starting positions to the locations of their neighbor’s corners (clockwise or counterclockwise). The motions of these cues were created by presenting 10 frames with a very short SOA (1 frame  $\approx 11.76 \text{ ms}$ ) between them. If the motion was clockwise, the first frame would contain four white circles ( $0.25^\circ$  radius) located separately at the four corners, centered  $3.16^\circ$  (left and right) and  $3.16^\circ$  (up and down) relative to the fixation point. Each subsequent frame would contain four new white dots, centered  $0.632^\circ$  closer to their clockwise neighbor corner. If the motion was counterclockwise, the first frame would contain the four white circles located separately at the four corners, centered  $3.16^\circ$  (left and right) and  $3.16^\circ$  (above and below)

relative to the fixation point. Each subsequent frame would contain four new white dots, centered  $0.632^\circ$  closer to their counterclockwise neighbor corner. The 10th frame, which contained four dots located at four corners just like the very first frame, was presented for a randomized time delay (SOAs): 50, 75, 100, 200, 300, 400 or 500 ms. After that, a horizontal green target bar, centered  $3.16^\circ$  (above or below) relative to the fixation point, was presented and remained present until the response triggered the next trial by indicating the direction of perceived motion (left or right) in a two alternative forced-choice design. 15% of the trials were control trials, which were similar to test trials except that the target bars in the control trials were composed of “real motion” as described above. The test trials, the motion of the cues (clockwise or counterclockwise), location of the target bar (above or below), and seven stimulus onset asynchronies (SOAs) were randomly mixed across 240 trials. Observers had to indicate the perceived direction of target bar motion by pressing one of two buttons on a USB mouse (a two-alternative forced-choice task).

## 6.2. Results

The results of Experiment 5 are shown in Fig. 8, where the percentage of IRM is plotted against SOA. The percentage of IRM is about 25% at all SOAs, indicating that not only was motion perceived, but also that “same-way motion” predominated. This finding

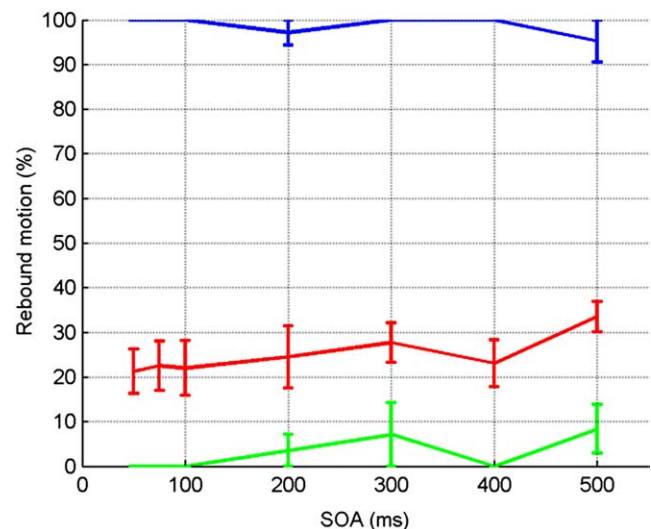

Fig. 8. Timecourse of Experiment 5. The percentage of IRM is about 25% at all SOAs, which means that no rebound motion was observed, rather subjects perceived “same-way motion”. The blue curve shows that in control trials that contained a “real rebound motion” relative to the direction of the cues, the percentage of trials where rebound motion was perceived was always high ( $>90\%$ ) with respect to any SOA. The green bar shows that in control trials that contained a “real same-way motion” relative to the direction of the cues, the percentage of trials where rebound motion was perceived was always low ( $<10\%$ ) with respect to any SOA.

supports the “trajectory continuity heuristic”. That is, the data are consistent with there being a heuristic to interpret the discrete appearance of an object as a motion signal away from the location at which a previously moving object stopped, with a motion trajectory that best continues in the direction of the previous trajectory.

### 6.3. Discussion

This experiment rules out the motion aftereffect as the cause of IRM. The MAE hypothesis predicts motion percepts (of IRM) in the direction opposite that observed. However, the data show that “same-way motion” is perceived, which supports the claim that a trajectory continuity heuristic operates in visual motion processing.

The results of this experiment also provide additional evidence against the attentional gradient hypothesis that we rejected on the basis of the results of Experiments 3 and 4. The attentional gradient hypothesis predicts that there should not be any perceived motion because attention should be equally distributed to the four corners after the four cues have stopped moving. Since attention at the four corners is presumably equal, there should either be no preference to see motion on the next target bar in any particular direction, or, if attentional gradients are set up at all four corners simultaneously, motion should appear to meet in the middle of the bar. Under a two-alternative forced-choice design that has been counterbalanced, there should therefore be no net preference to see motion in one direction or another. However, the results are contradictory to this prediction. Therefore, the attentional gradient hypothesis must be incorrect.

## 7. General discussion

In Experiments 1 and 2 we described a new illusory motion percept called “illusory rebound motion” (IRM). These experiments indicate that there is a minimum SOA necessary to create the percept of IRM, furthermore the percept of IRM persists over extended durations of time. Experiments 3–5 were designed to test possible hypotheses for the underlying mechanisms that drive the percept. Our data (Experiments 3–5) rule out the attentional gradient hypothesis, and imply that IRM and ILM are induced by some mechanism other than attentional gradients. We suspect that the percept of IRM is governed by a new heuristic principle according to which motion is perceived to move away from the location where it last occurred, in the absence of stimulus information suggesting otherwise. This heuristic hypothesis suggests that the visual system tends to interpret objects as moving from where they last stopped moving, and in a direction most consistent with that previous motion.

Evolution surely favored those visual systems that correctly represented information about events occurring in the world. Because objects rarely appear out of nowhere and rarely disappear into thin air, visual systems that made the conservative assumption that new motions are changes in the states of already existing objects would more likely represent the correct object motion than visual systems that assumed that motions emerge *de novo* upon each onset. For example, when a predator or prey animal appears to move after having stopped, or after having momentarily blended with the background due to camouflage, it would be ecologically sensible to see that animal move away from the location where it was last seen moving, rather than posit the disappearance of one animal and the spontaneous appearance of another.

The heuristic that motion continues from where it left off is closely related to another heuristic that was proposed by Anstis and Ramachandran (1987). They suggested that object motion trajectories have “visual inertia”. By this they meant that objects tend to travel in trajectories that maintain their direction of motion over time. For example, if two dots are placed on the opposite corners of an imaginary square and then replaced by two dots placed on the remaining corners, an ambiguous “quartets” apparent motion will result. On average, observers are as likely to see up-down as left-right motion in the quartets stimulus. However, if this ambiguous motion is preceded by left-right motion, such that the quartets apparent motion can be seen as the continuation of this motion, then the majority of observers see left-right motion in the quartets stimulus. It is as if objects are assumed to have a certain “momentum” and are therefore more likely to continue along the same trajectory they have been on. The present heuristic differs from the visual inertia heuristic in that motions can continue even after having stopped, and can lead to motion that violates the preference for trajectory continuity if the only motion path available is one that goes in the opposite direction of the previous motion, as in IRM. Both heuristics may be an example of a more general “motion continuity” heuristic which assumes continuous motion trajectories.

How heuristics might be implemented at the neuronal level is an open question. On the one hand, heuristics are high-level descriptions that summarize how the visual system appears to interpret ambiguous input in light of assumptions about how objects move in the world. On the other hand, there is no evidence that assumptions about object motion need to be realized in high-level neuronal mechanisms, such as top-down feedback from areas that process objects and scenes. It is entirely possible that heuristics are realized in a low-level and bottom-up manner. For example, a simple motion-energy detector circuit can be described as a series of propositions of the sort: “If rightward motion-energy, fire, if leftward,

do not fire”. But the actual implementation in terms of neural circuitry can be entirely non-propositional. Thus, although we discuss heuristics in terms of high-level propositions, such as “Select the possible motion that best maintains trajectory continuity”, there is no reason to think that such a heuristic cannot be realized in bottom-up, stimulus-driven processing by the neuronal circuitry underlying motion perception. Whether heuristics are realized in a bottom-up or top-down manner has not yet been resolved. However it is neuronally realized, the motion continuity heuristic evolved because it usually helped the perceptual apparatus construct veridical information about events in the environment, despite the inherent ambiguity of sensory input.

### Acknowledgments

We thank Heather Kiefer for assistance in collecting data. This project was funded by NIH R03 MH0-609660-01 grant to P.U.T.

### References

- Anstis, S., & Ramachandran, V. S. (1987). Visual inertia in apparent motion. *Vision Research*, 27(5), 755–764.
- Carrasco, M., Ling, S., & Read, S. (2004). Attention alters appearance. *Nature Neuroscience*, 7, 308–313.
- Carrasco, M., & Yeshurun, Y. (1998). The contribution of covert attention to the set-size and eccentricity effects in visual search. *Journal of Experimental Psychology: Human Perception and Performance*, 24, 673–692.
- Downing, P., & Treisman, A. (1997). The line motion illusion: Attention or impletion? *Journal of Experimental Psychology: Human Perception and Performance*, 23, 768–779.
- Hikosaka, O., Miyauchi, S., & Shimojo, S. (1993a). Focal visual attention produces illusory temporal order and motion sensation. *Vision Research*, 33, 1219–1240.
- Hikosaka, O., Miyauchi, S., & Shimojo, S. (1993b). Voluntary and stimulus-induced attention detected as motion sensation. *Perception*, 22, 517–526.
- Kanizsa, G. (1951). Sulla polarizzazione del movimento gamma [The polarization of gamma movement]. *Archivio di Psicologia, Neurologia e Psichiatria*, 3, 224–267.
- Kanizsa, G. (1971). *Organization in vision: Essays on Gestalt perception*. New York: Praeger.
- Posner, M. I. (1980). Orienting of attention. *Quarterly Journal of Experimental Psychology*, 32, 3–25.
- Stelmach, L. B., & Herdman, C. M. (1991). Directed attention and perception of temporal order. *Journal of Experimental Psychology: Human Perception and Performance*, 17(2), 539–550.
- Stelmach, L. B., Herdman, C. M., & McNeil, R. (1994). Attentional modulation of visual processes in motion perception. *Journal of Experimental Psychology: Human Perception and Performance*, 20, 108–121.
- Sternberg, S., & Knoll, R. L. (1973). The perception of temporal order: Fundamental issues and a general model. In S. Kornblum (Ed.), *Attention and performance IV* (pp. 629–685). New York: Academic Press.
- Titchener, E. B. (1908). *Lecture on the elementary psychology of feeling and attention*. New York: McMillan.
- Tse, P. U., & Cavanagh, P. (1995). Line motion occurs after surface parsing. *Investigative Ophthalmology and Visual Science*, 36, S417 [Abstract].
- Tse, P. U., Cavanagh, P., & Nakayama, K. (1996). The roles of attention in shape change apparent motion. *Investigative Ophthalmology and Visual Science*, 37, S213 [Abstract].
- Tse, P. U., Cavanagh, P., & Nakayama, K. (1998). The role of parsing in high-level motion processing. In T. Watanabe (Ed.), *High-level motion processing—computational, physiological and psychological approaches* (pp. 249–266). Amsterdam: North Holland.
- Tse, P. U., & Logothetis, N. K. (2002). The duration of 3-D form analysis in transformational apparent motion. *Perception & Psychophysics*, 64(2), 244–265.
- Tse, P. U., Sheinberg, D. L., & Logothetis, N. K. (2002). Fixational eye movements are not affected by abrupt onsets that capture attention. *Vision Research*, 42, 1663–1669.
- Wohlgemuth, A. (1911). In *On the after-effect of seen movement*. University of London.
- Yeshurun, Y., & Carrasco, M. (1999). Spatial attention improves performance in spatial resolution tasks. *Vision Research*, 39, 293–306.