

Available online at [www.sciencedirect.com](http://www.sciencedirect.com)

ScienceDirect

Procedia CIRP 21 (2014) 159 – 164

[www.elsevier.com/locate/procedia](http://www.elsevier.com/locate/procedia)

24th CIRP Design Conference

## Design and Evaluation of In-Line Product Repair Strategies for Defect Reduction in the Production of Electric Drives

M. Colledani<sup>a\*</sup>, D. Coupek<sup>b</sup>, A. Verl<sup>b</sup>, J. Aichele<sup>c</sup>, A. Yemane<sup>a</sup><sup>a</sup>Politecnico di Milano, Mechanical Engineering Department, Via la Masa, 1, 20156, Milano, Italy<sup>b</sup>Institute for Control Engineering of Machine Tools and Manufacturing Units (ISW), Seidenstraße 36, 70174 Stuttgart, Germany<sup>c</sup>Corporate Research Robert Bosch GmbH, Postfach 300240, 70442 Stuttgart, Germany\* Corresponding author. Tel.: +39-02-23998587; fax: 39-02-23998585. E-mail address: [Marcello.colledani@polimi.it](mailto:Marcello.colledani@polimi.it)

### Abstract

Manufacturing companies are continuously facing the challenge of operating their manufacturing processes and systems in order to deliver the required production rates of high quality products of increasing complexity, with limited use and waste of resources. This aspect is particularly critical in emerging sectors, such as the e-mobility industry, where state of the art quality and process control technologies show strong limitations. This paper proposes new solutions for implementing in-line product repair strategies in the production of electric drives for the automotive industry. Moreover, it develops an innovative quantitative tool to estimate the impact of the proposed strategies on the overall process-chain performance. The benefits of the approach are validated within a real industrial context.

© 2014 Published by Elsevier B.V. This is an open access article under the CC BY-NC-ND license

(<http://creativecommons.org/licenses/by-nc-nd/3.0/>).

Selection and peer-review under responsibility of the International Scientific Committee of “24th CIRP Design Conference” in the person of the Conference Chairs Giovanni Moroni and Tullio Tolio

Keywords: Product Repair, Electric Drives Assembly, Zero-defect Manufacturing;

### 1. Introduction, Motivation and Objectives

“Zero Defect Manufacturing” is an emerging paradigm aiming at going beyond traditional six-sigma approaches in highly technology intensive and emerging strategic manufacturing sectors through knowledge-based approaches. Traditional six-sigma techniques show strong limitations in highly turbulent, variable and changeable production contexts, characterized by small batch productions and in-line product inspections. Innovative and integrated product, process and system design, management and control methods as well as advanced technological enablers have a key role to achieve the overall “Zero Defect Manufacturing” objective.

The work proposed in this paper is part of the activity of the European funded project “MuProD - Innovative proactive quality control system for in-process multi-stage defect reduction”. The zero defect manufacturing paradigm proposed in MuProD is based on methodological and technological advances tackling both the defect generation phase, i.e. at

process level the creation of a non-conformity on the manufactured workpiece, and the defect propagation phase, i.e. at process-chain level, the transmission of a defect throughout the stages of the manufacturing system. The work reported in this paper is focused on this second issue.

#### 1.1. Industrial context of reference

Cars are with about 12 million manufactured units (EU27) one of the most important products in Europe. Due to the threatening lack of petrol and efforts for a healthy environment the change from the combustion engine towards electrical drives in cars is on going. For example, suppliers and car manufacturers in Germany are working together to reach the ambitious goal of 1 million sold electrical vehicles in 2020. Therefore, the current manufacturing processes for producing electrical drives must be improved to support the achievement of this goal. As a result of the complete different construction technique of electrical motors, the perfected

methods of manufacturing and quality control of combustion engines cannot be directly transferred to electrical drives.

In the production of automotive electric drives, the state of the art quality control is the so called “End Of Line” (EOL) testing, as the major final product functional and quality test and as approval test for the customers. This testing method is executed after all manufacturing steps have been completed and can therefore be classified as off-line inspection. If a defect occurs in one of the upstream production stages, it will not be detected in-line. Consequently, value adding processes will still be applied on an already defective product. Following the EOL testing approach, there is no possibility of applying in-process quality control techniques, since process data are not available at the relevant process stages.

To overcome this drawback, a new inline quality inspection strategy, involving a new device and a new methodology, is developed within the EU funded research project MuProD. In addition to EOL testing, inspections are also shifted to upstream process stages. By doing so, more detailed information about the product quality features can be gathered. For example, the currently applied total magnetic flux measurement of the laminated steel stacks can be replaced by a space-resolved measurement of the flux. This permits the identification and allocation of deviations in the magnetic field caused by specific defective or weak magnets. With this new inspection technology it is possible to support the development and implementation of advanced in-line strategies for profitably managing non-conforming stacks, thus avoiding the propagation of defects throughout the process stages. However, in order to select the most proper defect management strategy, the analysis of their impact on the overall integrated quality and production logistics performance of the process chain needs to be carried out.

### 1.2. Literature Review

The design and development of methodologies and technologies for defect management practices in the automotive industry, including in-line product repair, scrap, and rework have been recently addressed in the scientific literature. In [1] the problem of designing in-line rework practices in automotive paint shops, jointly considering quality and productivity implications, is addressed. Product repair and defect propagation in multi-stage systems has also been addressed in battery manufacturing [2]. The application of selective assembly strategies in the automotive industry has also been investigated. However, selective assembly is mainly being proposed for traditional mechanical problems, such as the sleeve-and-shaft type assembly. In [3] a General Selective Assembly approach is presented, which extends the classical approach of selective assembly. Repair strategies are identified as critical aspects in electric drive production. A prototype system for disassembly of internal magnets in a rotor stack for product repair is proposed in [4]. In [5] two possible assembly strategies were presented for the product repair in the production of electric drives. These strategies influence the performance of the overall production system and this aspect is generally neglected.

### 1.3. Objectives of the paper

As shown in the previous section, an approach for considering several different defect management actions in the same framework and evaluate their impact on the overall integrated quality and production logistics performance of the system has never been proposed. Moreover, advanced technologies for in-line repair of electric drives are currently not industrial state of the art solutions. Issues like “What is the impact of product rework at a given process stage on the output throughput of conforming items?” or “What are the overall benefits of selective assembly at system level?” still remain unsolved. The objective of this paper is to develop a general methodology and quantitative tools to design on-line defect management policies in manufacturing systems. The effectiveness of the proposed approach is demonstrated within the electric drive production system at Bosch. The paper is structured as follows: in Section 2, the current process-chain in the industrial case is described. In Section 3, the defect management strategies are described in detail. In Section 4, the developed system level model is explained and applied to the real system in Section 5. Results are shown in Section 6.

## 2. Description of the Rotor Assembly Line

The current production process for electric drives is represented in Fig. 1, where squares represent processing and inspection stages ( $M_i$ ) and circles represent buffers ( $B_{i,j}$ ) for storing inventory between  $M_i$  and  $M_j$ . The line produces a number  $T$  of different rotors,  $t=1, \dots, T$ . A rotor  $t$  is composed of  $S_t$  laminated stacks, which can be seen as the size of the batch of stacks to be assembled. Each stack has  $N_t$  magnets. The line is composed of two main branches, respectively dedicated to the assembly of the rotor and to the production of the stator. The focus of this study is the rotor line. This line is composed of seven main stages, dedicated to the following operations:

- $M_1$ : loading of the stacks on the pallet.
- $M_{2,1}, M_{2,2}$ : assembly of the magnets on the stacks. The station is composed of a pick and place system for positioning the magnets in their locations.
- $M_3$ : stack magnetization and total flux measurement.
- $M_4$ : heating station. A rotating table moves the stacks into a heating chamber.
- $M_5$ : assembly machine. The required number of stacks is taken and a pile of stacks in the z direction of the machine is formed by mounting each stack on the central shaft.
- $M_6$ : rotor balancing station.
- $M_7$ : rotor marking station.

After assembling the rotor and the stator, the completed motor undergoes the EOL inspection. At this stage, motor characteristics as well as customer requirements such as torque, speed, etc. are tested. Since defects in the magnetic circle have a considerable effect on the performance of the whole electric car, 100% EOL testing is needed.

Each stage in the system is subject to breakdowns, characterized by a failure rate  $p$ , which is the inverse of the mean time to failure, and a repair rate  $r$ , which is the inverse of the mean time to repair. The company collects estimates of these parameters. Their value is not provided for

confidentiality reasons. Moreover, each stage is characterized by a specific processing rate (parts/time) that is also omitted.

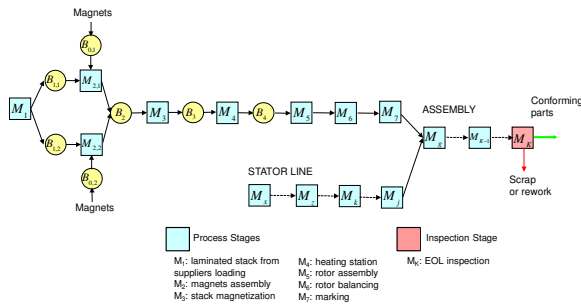

Fig. 1. Current production line for electric drives with EOL inspection.

In the current production line, several defect sources have been identified and classified. Each defect is coded as  $(i,j)$  where  $i$  indicates the stage where it is generated and  $j$  is a progressive index. These defects are described in Table 1.

After applying the MuProD solution to the production system, new measurement devices will be included at stages  $M_3$  and  $M_5$  for detection of deviations in the magnetic field of a single rotor stack and the complete rotor, respectively. In details, these actions will consist in:

- The implementation of a sensor for the space resolved measurement of the magnetic flux of each stack. This results in an inspection point located after machine  $M_3$ .
- The development of a new multi-sensor system distributed in the z axis of the rotor, for measuring the field of each stack in the assembled rotor and check for uniformity of the overall rotor magnetic flux after stage  $M_5$ .

### 3. Characterization of Defect Management Strategies

A reference framework that comprehensively describes all possible defect management actions is shown in Fig. 2. This is the basis for the selection of those technically feasible actions, among which the optimal solution to be implemented for each specific defect type can be selected. The main classes of defect management strategies include: (1) No action, (2) Scrap and (3) Repair. This last class includes different options that are further detailed and described, relating to the industrial reference case, in the following.

#### 3.1. In-line Rework

In-line rework involves product inspection and repair in the same process stage. In this way, the defective part can be corrected without re-clamping. The workpiece repair can be performed by one of the following possible controller actions. Firstly, machine or process parameters can be adjusted; secondly, the actuators can be directly set, either by switching them on/off (e.g. heaters, valves) or by setting new continuous or discrete set-points; thirdly new code-segments to the numeric control of the machine can be generated and loaded.

In the production of electric drives, rotor assembly at stage  $M_5$  can be seen as a process with  $S_i$  stacks as input and exactly one complete rotor as output. The stacks enter the assembly

stage in the order in which they are produced in the previous stages. A priori, there is no knowledge available about the stacks and the magnetization of the single magnets. Therefore, no sorting policy is applied on the stacks before entering the assembly station. Once the stacks are piled up, the resulting rotor is inspected after  $M_5$  by a space resolved measurement of the magnetic field. Stacks containing magnets with deviations from the nominal value can be rotated for compensation if there is a second peak in a different stack. Then one stack can be rotated so that the weak magnet of the first stack is located next to the strong magnet of the second stack. If the deviation in the magnetic field exceeds the tolerances and cannot be compensated (e.g. broken magnet), then the defective stack has to be replaced by a stack from a buffer. In both cases, the output of the assembly process is a fully assembled rotor with a magnetic field that is within the desired tolerances.

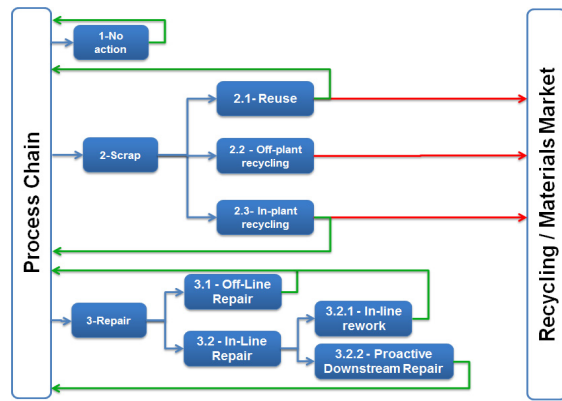

Fig. 2. Defect management actions: proposed reference framework. Red lines represent costs for the company.

#### 3.2. Downstream Repair

As deviations in the magnetic field of single rotor stacks are generated at stage  $M_3$ , the goal is to measure them after  $M_3$  and to compensate these deviations by applying an optimal strategy  $\pi^{opt}$  in the downstream assembly stage  $M_5$ , where a number  $S_i$  of stacks is assembled to form one rotor. Two possible downstream repair methods are investigated, namely sequential assembly and selective assembly.

**Sequential Assembly.** A batch of  $S_i$  stacks is produced, stored in a buffer and inspected, so that  $S_i$  magnetic profiles  $B_s(n)$ ,  $n=1, \dots, N_s$ , are available, where  $n$  indicates the specific magnet. The space resolved measurement of stacks yields the profiles matrix  $B$ .

$$B = \begin{bmatrix} B_1(n) \\ \vdots \\ B_{S_i}(n) \end{bmatrix} = \begin{bmatrix} b_{1,1} & \dots & b_{1,N_s} \\ \vdots & & \vdots \\ b_{S_i,1} & \dots & b_{S_i,N_s} \end{bmatrix} \quad (1)$$

The aim of this approach is to change the stack order and to impose an angular misalignment  $\alpha$  between the  $S_i$  stacks with respect to a reference axis in order to gain uniformity and reduce variability of the output field intensity. This yields the optimal sequential assembly strategy  $\pi^{opt}$  for a specific batch

of measured  $S_i$  stacks. The entity of the misalignment, namely the elements of the vector  $\alpha$ , has to be computed by an optimization algorithm. In order to find the global optimum a brute-force method is used as it searches for the minimum in the complete solution space. The number of possible permutations  $\pi^{all}$ , as well as the computational time, grow exponentially with respect to the number of stacks  $S_i$ .

$$\pi^{all} = \binom{N_S}{2}^{S-1} \tag{2}$$

To reduce the computational effort and consequently the negative influence on the production cycle time, the value of  $\pi^{all}$  has to be decreased, with the risk of deteriorating the quality of the proposed assembly strategy  $\pi^{opt}$ . Two strategies are investigated for reducing the number of combinations. The first approach is to consider only stacks with magnets out of tolerances in order to decrease the exponent of  $\pi^{all}$ . The second approach aims at reducing  $\pi^{all}$  by consideration of the most relevant magnets of the stacks within one batch.

**Selective Assembly.** In industry, selective assembly is applied to produce high precision assemblies from low precision components [6]. Selective assembly consists in measuring the key quality characteristics of each sub-component and sorting the components into bins according to the measurement outcome. Depending on the space resolved magnetic field measurement  $B_i(n)$  of each stack, clusters of stacks  $C_i$  are formed and the stacks are temporarily stored in class-dependent buffers. The binning strategy  $\pi^{binning}$  fixes the number of clusters and the sorting policy. For improving the product quality, the assembly station is allowed to assemble components only according to the assigned bins' matching policy  $\pi^{matching}$ . This strategy determines how many stacks have to be taken from each class  $C_i$  to form one rotor. The assembly policy  $\pi^{assembly}$  finally defines the loading policy from different classes.

3.2.1. Selection of Technically Feasible Actions

For each defect type, the technically feasible defect management actions, selected in the framework of Fig.2, are associated (Table 1). In order to select among the feasible actions the most suitable solution for each defect type a model will be presented that considers, at system level, the impact of the defect management action on the production logistics performance (Work in Progress, throughput) as well as on the quality performance (yield).

Table 1: Typical defects and corresponding potential management strategy.

Defect Code	Defect Description	Defect Category	Stage Generated	Stage Inspected	Feasible Actions
(2,1)	Missing magnet.	Binary	M <sub>2</sub>	M <sub>3</sub>	1, 2.1, 2.2, 3.1, 3.2.1, 3.2.2
(3,1)	Magnet with low magnetic field intensity.	Dimensional	M <sub>3</sub>	M <sub>3</sub>	1, 2.1, 2.2, 3.1, 3.2.1, 3.2.2
(3,2)	Non-uniform magnetic field intensity of the magnets in the stack.	Geometric	M <sub>3</sub>	M <sub>3</sub>	1, 2.1, 2.2, 3.1, 3.2.1, 3.2.2

(5,1)	Non-uniform magnetic field intensity of the stacks in the rotor.	Geometric	M <sub>5</sub>	M <sub>5</sub>	1, 2.1, 2.2, 3.1, 3.2.1
-------	--	-----------	----------------	----------------	-------------------------

4. Production Line Model

A generalized production system model for the joint analysis of quality and production logistics performance under application of the defect repair strategies is developed to study their influence at system level. The proposed model analyzes a general manufacturing system that is composed of multiple processing stages (blue squares) and inspection stages (red squares) defined as  $M_k, k=1, \dots, K$ , (Fig. 3).

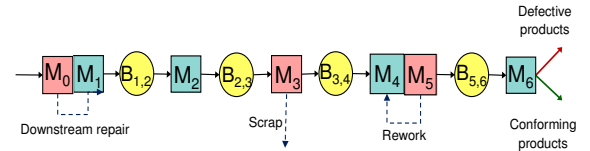

Fig. 3. Modelling formalism for a generic multi-stage production line.

Individual stages are connected by material transportation systems or inter-operational buffers (yellow circles),  $B_{i,j}$  storing work in progress between stage  $M_i$  and  $M_j$ . For example, in Fig. 3, processing stages  $M_1, M_2$  and  $M_4$  perform manufacturing transformation processes on the incoming workpieces. Inspection stations  $M_0, M_3$  and  $M_5$  measure key quality features of parts processed at upstream manufacturing stages. Based on the information collected by inspection machines and these actions are indicated in blue arrows.

The behaviour of each stage is modelled as a continuous time-discrete state Markov chain of general complexity. The underlying transition rate matrix is  $\lambda$ . This framework allows to model machines having multiple operational and failure states, connected by means of an arbitrarily complex Markovian structures. When the machine is in an operational state  $o$ , it processes parts at a rate of  $\mu_o$  parts per minute. A breakdown state is simply characterized by  $\mu=0$ . These processing rates [parts/t.u.] are collected in the quantity reward vector  $\mu$ . For each operational state a statistical distribution of the processed quality characteristic  $y$  is assumed, namely  $f_o(y)$ . According to the Specification Limits imposed by design on the processed feature, the yield is defined for every state  $o$ , namely  $Y_o$ ; these elements are collected in the quality reward vector  $Y$ . The total fraction of defects generated by the stage is denoted as  $\gamma$ . The performance measures of interest are the following:

- Average total production rate of the system,  $E^{Tot}$ , including both conforming and defective parts, observed in output.
  - Average effective production rate,  $E^{Eff}$ , of conforming parts, observed in output.
  - System yield,  $Y^{system}$ , that is the fraction of conforming parts produced by the system ( $E^{Eff} / E^{Tot}$ ).
  - WIP, which is the total average inventory of the system.
- Having derived the characteristic parameters ( $\lambda_i, \mu_i, Y_i$ ) for each stage, the steady-state probability vector  $\pi_i$  of the

Markov chain and the performance of the stage in isolation, i.e. not integrated in the production line, can be computed:

$$\pi_i \lambda_i = 0$$

$$E_i^{Tot} = \pi_i \cdot \mu_i^T \quad E_i^{Eff} = \pi_i \cdot \text{diag}(\mu_i) \cdot Y_i^T \quad Y_i^{M_i} = \frac{E_i^{Eff}}{E_i^{Tot}} \quad (3)$$

The above formalism does not consider the application of the defect management actions. Since the defect management policies affect the material flow and the behavior of stages, this impact has to be included in the stage models.

**5. Modeling the Effect of Defect Repair Strategies at Process-chain Level**

*5.1. Model of a stage performing scrap*

Scrapping can be an appropriate policy on defective parts if repairing the non-conformity is not economical or is technically infeasible. There are different actions that can be considered as post treatment for the scrapped parts that might entail further decisions, as sketched in the defect classification framework of Fig. 2. However, in this analysis, these further decisions are neglected. The state transition diagram of a machine with single failure mode without (a) and with (b) the scrapping policy is shown in Fig. 4. The transition rates can be evaluated using equation (4). State *U* is the operational state and *D* is the down state. Since produced parts do not proceed to the next stages when scrapping is activated, the processing rate of the scrapping state *Sc* is set to 0.

$$P_{sc} = \mu_U \cdot \gamma$$

$$r_{sc} = \mu_U \cdot (1 - \gamma) \quad (4)$$

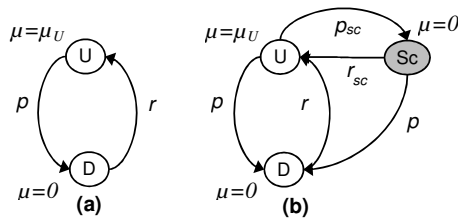

Fig. 4. State transition diagram of stages without (a) and with (b) scrapping.

*5.2. Model of a stage performing inline rework*

The main logistics consequence of inline rework is related to the need to reprocess the fraction  $\gamma$  of defective parts generated by the stage. After the reprocessing, it is assumed that the reworked parts continue the flow in the remaining portion of the line. In Fig. 5(a) the state transition diagram of a stage performing rework is presented.

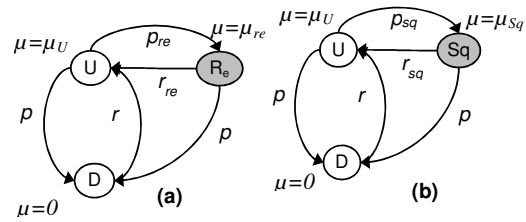

Fig. 5. State transition diagram of stages performing rework (a) and sequential assembly (b).

The modelling of this policy requires knowledge on the time required for the rework operation i.e. *RT*. The adjusted transition rates and processing rates of the machine in the reworking state (*R<sub>e</sub>*) can be evaluated with equations (5).

$$P_{re} = \mu_U \cdot \gamma$$

$$r_{re} = \mu_U \cdot (1 - \gamma)$$

$$\mu_{re} = \frac{\mu_U}{1 + RT \cdot \mu_U} \quad (5)$$

*5.3. Model of a stage performing downstream repair policies*

*Sequential assembly:* under the sequential assembly policy the machine performs measurement, optimization and assembly of components, according to the optimized angle. Since additional time is needed for these activities, the production logistics behavior of this stage needs to be adjusted accordingly. Consequently, this policy can be modeled with the state transition diagram in Fig. 4, with the specific set of transition and processing rates given in equation (6). In this case, the times related to assembly (*T<sub>asbl</sub>*), inspection (*T<sub>insp</sub>*), optimization (*T<sub>opt</sub>*), and additional operations, i.e. part positioning (*T<sub>add</sub>*) must be considered.

$$P_{sq} = \mu_U \cdot \gamma$$

$$r_{sq} = \mu_U \cdot (1 - \gamma)$$

$$\frac{1}{\mu_U} = T_{asbl} + T_{insp}; \quad \frac{1}{\mu_{sq}} = T_{asbl} + T_{insp} + T_{add} + T_{opt} \quad (6)$$

*Selective assembly:* By employing selective assembly, high precision products can be assembled from low precision components, at the cost of increasing the complexity of the system management. In the reference industrial case, selective assembly is applied as follows. Each stack is sorted in two classes depending on the measured total magnetic flux intensity. The buffer size for the two classes is identical and equal to half the size of the buffer in the current configuration. Then, the assembly machine only couples stacks with high flux with stacks with low flux intensity. Due to the complexity in the system management, modeling selective assembly requires more technical mathematical derivations than previous defect management policies. Due to space limitations, we omit this derivation. It can be found in [7].

5.4. System Performance Evaluation

The proposed analytical method is based on a recent idea of decomposition approach that applies to Markovian machines, characterized by transition rate matrix  $\lambda$  and processing rate vector  $\mu$ , that was recently proposed in [8]. Therefore, it applies to the stage models described in the previous section. The idea of the decomposition approach is to decompose the  $K$ -machine system into a set of  $K-1$  two-machine one-buffer sub-systems  $l(k)$ , i.e. one for each buffer in the original system. The performance of each sub-system can be evaluated with the exact analytical method developed in [9]. The decomposition equations for such general system settings are provided in [8]. This method proved to be accurate in estimating the system performance, showing errors against simulation below 3%.

6. Numerical Results and Strategy Comparison

By combining the stage level defect management policies described in the previous sections and associated to each defect type at production system level, six system level defect management scenarios have been generated for the electric drive production system under analysis. Considering the existing defect management policy (no action) as the baseline case, five additional scenarios are evaluated and compared in terms of system performance. The five scenarios are:

- Scenario 1: scrap at  $M_3$  and rework at  $M_5$ .
- Scenario 2: no action at  $M_3$  and rework at  $M_5$ .
- Scenario 3: scrap at  $M_3$  and sequential assembly at  $M_5$ .
- Scenario 4: no action at  $M_3$  and sequential assembly at  $M_5$ .
- Scenario 5: no action at  $M_3$  and selective assembly at  $M_5$ .

The results are summarized in Table 2. As shown, the application of the best scenario (scenario 4) can yield an improvement of 16.55% in the production rate of conforming parts of the system (the time unit is hidden for confidentiality reasons). The proposed approach for the quantitative analysis of defect management policies at system level suitably supports the strategy design in industrial settings.

Table 2: Comparison of scenarios; electric drive production system.

Strategy	$E^{Eff}$ [parts/t.u]	$E^{Tot}$ [parts/t.u]	$\gamma^{system}$	$\Delta\% E^{Eff}$ vs. Baseline
Base line	0.5752	0.6729	0.85	-
Scenario 1	0.6478	0.6478	1.00	+12.62%
Scenario 2	0.5693	0.5693	1.00	-1.04%
Scenario 3	0.6613	0.6613	1.00	+14.96%
Scenario 4	0.6704	0.6704	1.00	+16.55%
Scenario 5	0.6261	0.6726	0.93	+8.85%

7. Conclusions and Guidelines for Implementation

The paper proposes several technical solutions for avoiding the propagation of defects in multi-stage production lines and

a quantitative methodology to support the design of the best possible strategy by estimating the impact of the actions on the overall system performance. The benefits of the approach are demonstrated within a real industrial process-chain, dedicated to the production of electric drives.

Some guidelines for the implementation of the tools supporting this approach are given. Although it is a system level approach, some aspects are not directly taken into account. The implementation of selective and sequential assembly strategies in the production system of electric drives requires additional component handling devices. In addition, by using an optimal matching policy, the inspection of the entire rotor could be removed. Furthermore, the algorithms for solving the sequential assembly optimization problems in real-time require high calculation capacity, which must be provided by adequate computers or machine controls. These implications should be considered before implementation.

The proposed approach is general and applicable to systems in several industries, thus paving the way to the implementation of the zero-defect manufacturing paradigm in industry.

Acknowledgements

The research leading to these results has received funding from the European Union Seventh Framework Program (FP7/2007-2011) under grant agreement n° 285075.

References

- [1] Li, J., Blumenfeld, D.E., Marin, S.P. Manufacturing system design to improve quality buy rate: an automotive paint shop application study. IEEE Trans Autom Sci Eng 2007; 4 (1), 75-79.
- [2] Ju, F., Li, J., Xiao, G., Huang, N., Biller, S. A quality flow model in battery manufacturing systems for electric vehicles. To appear in IEEE Trans Autom Sci Eng, 2013.
- [3] Tan, M., Wu, C. Generalized selective assembly. IIE Transactions 2012; 44(1), 27-42.
- [4] Klier, T., Risch, F., Franke, J. Disassembly strategies for recovering valuable magnet material of electric drives. Proceedings of the 3rd Int. EDPC, IEEE Catalog Number CFP1385P-PRT, 2013, pp. 12-14.
- [5] Coupek, D., Verl, A., Aichele, J., Colledani, M. Proactive Quality Control System for Defect Reduction in the Production of Electric Drives. Proceedings of the 3rd Int. EDPC, IEEE Catalog Number CFP1385P-PRT, 2013, pp. 440-445.
- [6] Iyama, T., Mizuno, M., McKay, K. N., Yoshihara, N., Nishikawa, N. Optimal strategies for corrective assembly approach applied to a high-quality relay production system. Comput Ind 2013; 64, 556-564.
- [7] Colledani, M., Ebrahimi, D. Performance Evaluation of Selective and Adaptive Assembly Systems. SMMSO 2013.
- [8] Colledani, M., Gershwin, S.B. A Decomposition Method for Approximate Evaluation of Continuous Flow Multi-stage Lines with General Markovian Machines, Ann Oper Res 2012; 209(1), 5-40.
- [9] Gershwin, S., Tan, B. Analysis of a general Markovian two-stage continuous flow production system with a finite buffer. Int J Prod Econ 2009; 120(2), 327-339.