

Available online at [www.sciencedirect.com](http://www.sciencedirect.com)**SciVerse ScienceDirect**

Energy Procedia 14 (2012) 364 – 369

Energy

**Procedia**

# 2011 2nd International Conference on Advances in Energy Engineering (ICAEE 2011) Permanent Magnet Synchronous Motor with Linear Quadratic Speed Controller

Wen-Jun Xu

*School of Urban Rail Transportation, Soochow University, No.178 East Ganjiang Road Suzhou Jiangsu 215000, China*

---

## Abstract

A linearized mathematical model of Permanent Magnet Synchronous Motor is proposed with the help of vector control method and the definition of new variables. Then Linear Quadratic regulator (LQR) control methodology is investigated and an optimal speed controller is designed for PMSM system. The control performance of LQR is compared with that of traditional PID controller in Simulink environment of MATLAB. Simulation results indicate that the PMSM system using proposed LQR control methodology has better dynamic performance and stronger robustness than using traditional PID controller.

© 2011 Published by Elsevier Ltd. Selection and/or peer-review under responsibility of the organizing committee of 2nd International Conference on Advances in Energy Engineering (ICAEE). Open access under [CC BY-NC-ND license](http://creativecommons.org/licenses/by-nc-nd/3.0/).

*Keywords:* Permanent Magnet Synchronous Motor (PMSM), Linear Quadratic Regulator(LQR), PID controller, Simulink.

---

## 1. Introduction

In this paper, vector control theory [1] is discussed in control of PMSM. It is because of the vector control theory that performance of PMSM servo drive reaches and even surpluses that of dc drives. Vector control theory with the help of the principle of Clarke and Park transforms, transforms the actual three phase current into the corresponding torque current and field current in order to decouple the mathematical control model of PMSM.

As the PMSM motor is replacing the conventional dc motor for small output power rating variable speed control system, the performance of PMSM which requires quick transient response must be improved [2]. PID controller has been dominating the control system of PMSM especially in practical conditions, however the performance of PMSM using PID controller is not always satisfactory. Hence, alternative methods like Linear Quadratic Regulator (LQR) is being used in speed control of PMSM [3][4]. LQR is an optimal control methodology that uses the quadratic cost function to determine its

---

\*Wen-Jun Xu. Tel.: 86-15106206270

E-mail address: [xuwenjunwendy@hotmail.com](mailto:xuwenjunwendy@hotmail.com).

control performance. In order to apply LQR to the speed control system of PMSM, however, the original non-linear, mathematical model of PMSM must first be linearized. The linearization method proposed in [5][6] was used.

The focus of this paper is to apply the method of LQR to improve the dynamic performance of PMSM. The arrangement of the paper is as follows: description of linearized, decoupled mathematical model of PMSM is presented in section 2. The principle of LQR and the design of a speed controller using optimal control method is introduced in section 3. Section 4 introduces the simulation models of PMSM with PID controller and LQR respectively and the comparison of simulation results of these two control methods. Section 5 concludes the entire paper.

## 2. Mathematical model of PMSM

The equations that govern the electric dynamics of PMSM are expressed in the rotor reference frame (qd frame) as follows:

$$\frac{d}{dt}i_d = \frac{1}{L_d}v_d - \frac{R}{L_d}i_d + \frac{L_q}{L_d}p\omega_r i_q \quad (1)$$

$$\frac{d}{dt}i_q = \frac{1}{L_q}v_q - \frac{R}{L_q}i_q - \frac{L_d}{L_q}p\omega_r i_d - \frac{\lambda p\omega_r}{L_q} \quad (2)$$

$$T_e = 1.5p[\lambda i_q + (L_d - L_q)i_d i_q] \quad (3)$$

Where:

$L_q$  and  $L_d$  are  $q$  and  $d$  axis inductances;

$R$  is the resistance of the stator windings;

$i_q$  and  $i_d$  are  $q$  and  $d$  axis currents;

$v_q$  and  $v_d$  are  $q$  and  $d$  axis voltages;

$\omega_r$  is the angular velocity of the rotor;

$\lambda$  is the amplitude of the flux induced by the permanent magnets of the rotor in the stator phases;

$p$  is number of pole pairs;

$T_e$  is electromagnetic torque.

The dynamic model of PMSM described by equation (1) and (2) is nonlinear due to the cross coupling and the angular speed and current produced in  $d$  and  $q$  axis respectively. The linearization process of the above model of PMSM was conducted by defining new variables which is described in detail in [6]. If we consider the magnetic symmetry in the motor which is often the case in PMSM of many kinds (like surface mounted PMSM for example), then inductance in  $d$  axis is equal to inductance in  $q$  axis. So we define:  $L_q = L_d = L$ . New variables are given as follows:

$$v_{d0} = -LP\omega_r i_q \quad (4)$$

$$v_{q0} = LP\omega_r i_d \quad (5)$$

After equations (4) and (5) have been put into equations (1) and (2), the linearized dynamic model of PMSM takes the form of following equations:

$$\frac{d}{dt}i_d = \frac{1}{L}v_d - \frac{R}{L}i_d \quad (6)$$

$$\frac{d}{dt}i_q = \frac{1}{L}v_q - \frac{R}{L}i_q - \frac{\lambda p \omega_r}{L} \quad (7)$$

It can be seen from equations (6) and (7) that the dynamical model of PMSM has been decoupled because the current in  $d$  axis has relations with variables in  $d$  axis only, it is the same case in  $q$  axis.

The mechanical model for PMSM is presented by the following two equations:

$$\frac{d}{dt}\omega_r = \frac{1}{J}(T_e - D\omega_r - T_L) \quad (8)$$

$$\frac{d}{dt}\theta = \omega_r \quad (9)$$

Where:

$J$  is the combined inertia of rotor and load;

$D$  is the damping coefficient.

$\theta$  is rotor angular position;

$T_L$  is the load torque.

The above equations (3), (6), (7) and (8) can be used to form a continuous state-space model for PMSM as follows:

$$\dot{x} = Ax + Bu + Ew \quad (10)$$

Where  $x$  is the state vector which takes the forms of  $x = [i_q \ i_d \ \omega_r]^T$ ;  $u$  is the input vector which is given by:  $u = [v_q \ v_d]^T$ ;  $w$  is the disturbance input of the system, in this case it can be considered as the mechanical load which is governed by  $w = T_L$ . Matrices A and B of the state space model can be described as follows:

$$A = \begin{bmatrix} -\frac{R}{L} & 0 & \frac{\lambda P}{L} \\ 0 & -\frac{R}{L} & 0 \\ \frac{1.5P\lambda}{J} & 0 & -\frac{D}{J} \end{bmatrix}, B = \begin{bmatrix} \frac{1}{L} & 0 \\ 0 & \frac{1}{L} \\ 0 & 0 \end{bmatrix}, E = \begin{bmatrix} 0 \\ 0 \\ -\frac{1}{J} \end{bmatrix} \quad (11)$$

The vector control method, which is based on field orientation, is constantly applied in the control of PMSM. Specifically, we use the method which requires  $i_d$  to be kept as zero [7], so that the stator current vector is kept along  $q$  axis direction and the electromagnetic torque is linearly proportional to the  $q$  axis current which is determined by closed loop control. This method is easy to apply but can lead to high dynamic performance. In this way, the state-space dynamic model of PMSM can be further simplified while still take the form of equation (10) but with different definitions of the parameters in the equation. Please refer to the following description.

$$\begin{aligned} \dot{x} &= Ax + Bu + Ew \\ y &= Cx \end{aligned} \quad (12)$$

$$x = [i_q \quad \omega_r \quad \theta_r]^T, u = v_q, w = T_L \quad (13)$$

$$A = \begin{bmatrix} -\frac{R}{L} & -\frac{\lambda P}{L} & 0 \\ \frac{1.5P\lambda}{J} & -\frac{D}{J} & 0 \\ 0 & 1 & 0 \end{bmatrix}, B = \begin{bmatrix} \frac{1}{L} \\ 0 \\ 0 \end{bmatrix}, E = \begin{bmatrix} 0 \\ \frac{1}{J} \\ 0 \end{bmatrix}, C = [0 \quad 1 \quad 0] \quad (14)$$

### 3. Design of Optimal Linear Quadratic Regulator

The linear quadratic regulator (LQR) is an optimal control methodology of dynamic systems where the state equation of the plant is linear and the cost function is quadratic. It can be seen from equations (12) to (14) that the output variable is also the state variable, so the LQR designed is both state regulator and output regulator. The cost function can be described as the following equation:

$$J = \frac{1}{2} \int_0^{\infty} (x^T Q x + u^T R u) dt \quad (15)$$

Where  $Q \in R^{n \times n}$  is the symmetric semi-positive or positive definite matrix and  $R \in R^{m \times m}$  is the symmetric positive definite matrix.

The optimal feedback gain matrix  $K = [k_1 \quad k_2 \quad k_3]$  makes the cost function take the minimum value that satisfies the equation:

$$K = R^{-1} B^T P \quad (16)$$

Where P is the real positive definite solution of the following Riccati equation:

$$A^T P + P A - P B R^{-1} B^T P + Q = 0 \quad (17)$$

So the optimal control is given by:

$$u = -Kx \quad (18)$$

In order to obtain fast response and good dynamic performance of the system, the weight matrices  $Q$  and  $R$  must be chosen properly [8]. In this case we set  $Q = \text{diag}[100 \quad 1 \quad 1]$  and  $R = 1$ , then the corresponding optimal feedback gain is  $K = [7.9117 \quad 0.7249 \quad 1.0000]$ .

### 4. Simulation and results

In order to validate the LQR control methodologies of PMSM and its advantages over the traditional PID controller, we use the Simulink environment in MATLAB as the simulation tool.

The simulation model of PMSM system [9] consists of six major blocks: the PMSM block, the PWM inverter block, Clarke and Park transforms block, current to voltage transforming block, current regulation block and speed control block. The simulation models of PMSM which use PID controller and LQR control methodology are shown in Fig.1 and Fig.2 respectively.

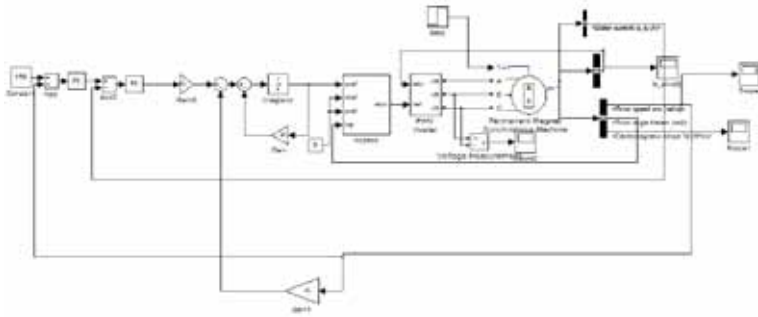

Fig. 1 Simulation model of PMSM system which uses traditional PID controller

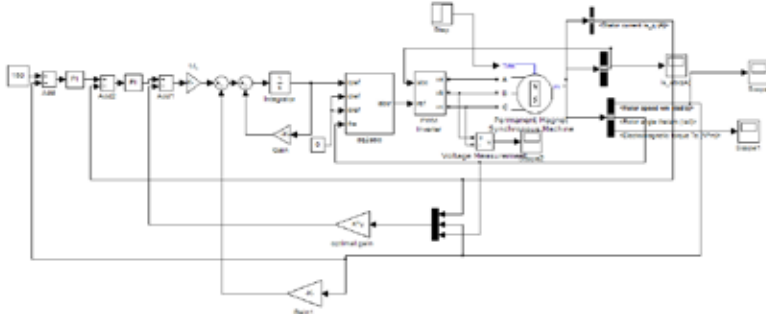

Fig. 2 Simulation model of PMSM system which uses LQR control methodology

The parameters of PMSM used in the simulation process are as follows:

$$R = 2.875\Omega, L = 8.5mH, P = 2, \lambda = 0.175Wb, J = 0.0008kg.m^2, D = 0.0021N.m.s / rad.$$

Set the speed reference as 50r/min, the simulation results of speed response of PMSM system without disturbance load torque are shown in Fig.3 and Fig. 4. As can be seen from these two figures, the transition time of PMSM system using traditional PID controller is 0.01s, while the transition time of LQR control methodology(with the same PID parameter) is 0.0075s. Speed overshoot of PMSM system using PID controller is 32% while speed overshoot of LQR method is 10%. These results show that PMSM system using LQR control methodology has better dynamic performances in terms of transition time, speed overshoot etc.

At 0.04s, load torque of 3N.m is applied to the PMSM system as a disturbance input. The simulation results of speed response of the system with load disturbance are shown in Fig.5 and Fig. 6 respectively. The results show that PMSM system using LQR control methodology can return back to the steady state in situation of disturbance faster than system using traditional PID controller which indicates strong robustness of system using LQR control methodology.

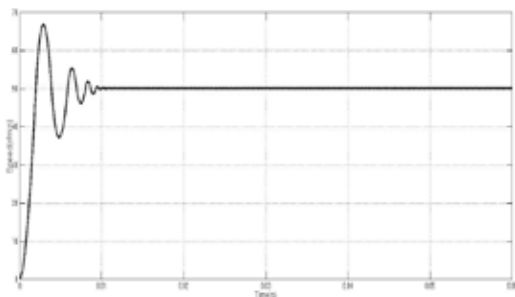

Fig. 3 Speed response of PID controller

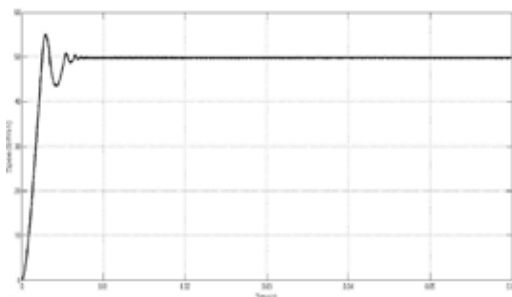

Fig. 4 Speed response of LQR

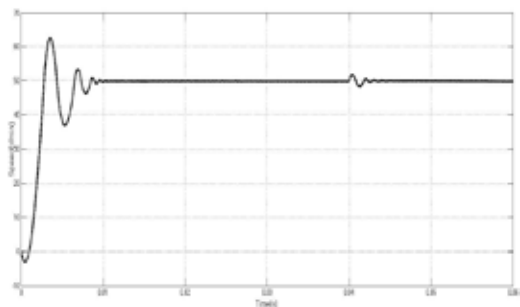

Fig. 5 Speed response of PID controller with load disturbance

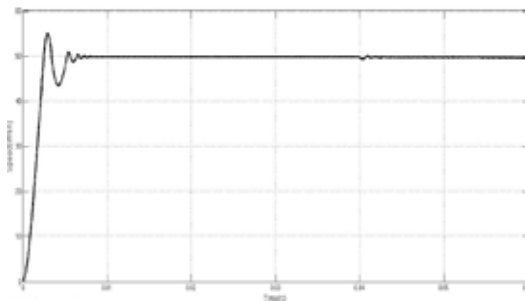

Fig. 6 Speed response of LQR with load disturbance

## 5. Conclusion

In this paper, the mathematical model of PMSM dynamic system was set up. Considering the nonlinearity and cross coupling of the system, a linearized model was proposed using the method of defining new variables and by applying the vector control method which requires  $i_d$  to be kept as zero.

The LQR control methodology was investigated and its control performance was compared with that of the traditional PID controller in a PMSM dynamic system. This was achieved with the help of Simulink environment of MATLAB. The simulation results validate the proposed LQR methodology and display a better dynamic performance in terms of transition time and speed overshoot and also stronger robustness of LQR control methodology than of traditional PID controller.

## Acknowledgement

The work described in this paper is fully sponsored by “Chun-Tsung Endowment”, an endowment dedicated to supporting young scholars from universities in mainland China and Taiwan for scientific researches, which was directed by doctor Tsung-Dao Lee

## References

- [1] N. P. Quang, Vector control of three-phase Ac machines, London: Springer Verlag, 2008
- [2] RB. Sepe, J.H. Lang, Real-time adaptive control of the permanent-magnet synchronous motor, *IEEE Transaction on Industry Application*, vol.28, no.6, pp.1345-1352,2002
- [3] M.Yin, W. Cong, J. Lin, L. Wang, Optimal Speed Control of PMSM for Electric Propulsion Based on Exact Linearization via State Feedback, *Proceedings of the 2010 IEEE International Conference on ICIA*, pp.1972-1977, 20-23 June 2010
- [4] R. Molavi, D. Khaburi, optimal control strategies for speed control of permanent-magnet synchronous motor drives, *Proceedings of World Academy of Science, Engineering and Technology*, vol. 34, pp.428-432, October.2008.
- [5] L.M. Grzesiak, T. Tarczewski, Permanent magnet synchronous discrete linear quadratic speed controller, *2011 IEEE Internatioanl Symposium on ISIE*, pp.667-672, 27-30 June 2011
- [6] L.M. Grzesiak, T. Tarczewski, Permanent magnet synchronous servo-drive with state position controller, *13<sup>th</sup> Power Electronics and Motion Control Conference. EPE-PEMC 2008*, pp.1071-1076
- [7] Y.P Xu, Y.R. Zhong, H.Yang, Research on vector control and direct torque control for permanent magnet synchronous motors, *Power Electronics*, vol.42, no.1, pp.60-62,2008.
- [8] C.X. Wang, Study of the weight matrix in LQR optimal control system, *Journal of Northwest Minorities University(Natural science)*, vol.24, no.2, pp.29-31,2003.
- [9] L.H. Hoang, Modeling and simulation of electrical drives using MATLAB/Simulink and power system blockset, *The 27<sup>th</sup> Annual Conference of the IEEE Industrial Electronics Society*, vol.3, pp.1603-1611,2001.