



15th CIRP Conference on Modelling of Machining Operations

Predictive modeling of surface roughness in grinding

Sanchit Kumar Khare^a, Sanjay Agarwal^{b,*}^aDepartment of Mechanical Engineering, Bundelkhand Institute of Engineering and Technology, Jhansi, India^bDepartment of Mechanical Engineering, Bundelkhand Institute of Engineering and Technology, Jhansi, India* Corresponding author. Tel.: +91-510-232-0394; fax: +91-510-232-0312. E-mail address: sanjay72ag@rediffmail.com**Abstract**

Surface quality of the machined component is one of the most important criteria for the assessment of grinding process. The importance of the surface finish of a product depends upon its functional requirements. Since surface finish is governed by many factors, its experimental determination is laborious and time consuming. So the establishment of a model for the reliable prediction of surface roughness is still a key issue for grinding. In this study, a new analytical surface roughness model is developed on the basis of stochastic nature of the grinding process, governed mainly by the random geometry and the random distribution of cutting edges on the wheel surface having random grain protrusion heights. A simple relationship between the surface roughness and the chip thickness was obtained, which was validated by the experimental results of AISI 4340 steel in surface grinding.

© 2015 The Authors. Published by Elsevier B.V. This is an open access article under the CC BY-NC-ND license

(<http://creativecommons.org/licenses/by-nc-nd/4.0/>).

Peer-review under responsibility of the International Scientific Committee of the “15th Conference on Modelling of Machining Operations

Keywords: Grinding; Surface roughness; Chip thickness

1. Introduction

Advanced engineering materials have been extensively used in industrial applications during the last two decades [1, 2]. However, the actual utilization of advanced ceramics has been quite limited mainly because of the machining difficulties and associated high cost of machining these materials by grinding while ensuring the workpiece quality. A technological basis to achieve more efficient utilization of the ceramic grinding process requires an understanding of the interaction between the abrasive and the workpiece, which has direct bearing on the surface roughness, produced using electron discharge machining. Although extensive research has been carried out to predict the surface roughness of the ground ceramic workpiece, a complete understanding is yet to be achieved.

Theoretical methods of surface roughness evaluation, as reported in the literature, can be classified into empirical and analytical methods. In empirical methods, the surface roughness model is developed as a function of kinematic conditions [3-4]. Although the development of empirical models require minimum efforts and are used in the field of grinding technology they have limited applicability. Hence,

the scope of these models is limited.

The analytical models are always preferred to empirical models as these models are deductively derived from fundamental principles. So, the main advantage of the analytical model is that the results can easily be transferred to other grinding conditions and other grinding processes. Hence, these results can be made applicable to a wide range of process conditions. The analytical models for surface roughness have always been characterized by the description of the microstructure of the grinding wheel, in one-dimensional form, taking the grain distance, the width of cutting edge and the grain diameter into account [5-7]. However, these models did not consider the different height of cutting edges and assumed that the distance between the cutting edges was uniform. Tonshoff et al. [8] described the state of art in the modeling and simulation of grinding processes comparing different approaches to modeling. This work identified one simple basic model where all the parameters such as wheel topography, material properties, etc. were lumped into the empirical constant.

Several analytical models, based on stochastic nature of grinding process, were proposed [9-11] to simulate the surface profile generated during grinding. Assuming a particular

probability distribution of these random cutting points, output surface profiles were generated for known input surface profile and input grinding conditions. Experiments conducted by Lal and Shaw [12] with single abrasive grain under fine grinding conditions indicated that the grain tip could be better approximated by circular arc. Therefore, it is evident that the groove produced by an individual grain can be better approximated by an arc of a circle. Based on this concept, Agarwal and Rao [13-15] developed an analytical model for the prediction of surface roughness in ceramic grinding. A probabilistic approach, for geometric analysis of the grooves generated, was used to describe the surface roughness, in which, the random variable had been defined by undeformed chip thickness probability density function. A simple relationship between the surface roughness and the undeformed chip thickness was found.

In this paper, an analytical model has been envisaged to evaluate surface roughness from the chip thickness probability density function. A simple relationship between surface roughness and the chip thickness has been established with the chip thickness as random variable. The model is then verified using experimental data from the surface grinding of AISI 4340 steel with aluminum oxide abrasive.

2. Model development

A schematic diagram showing the transformation of the grain tip to the work piece is given in Fig. 1. At any transverse section, the profile of groove generated by any grain is as shown in Fig. 2. Since an individual grain has many tiny cutting points on its surface and the speed ratio is high, the groove produced by an individual grain can be assumed to be an arc of a circle. It can be further assumed that the material is either plowed with little side pile-up or removed in the form of chips whenever grain-work piece interference occurs. Since the position of grain tip will be random due to random occurrence of grains on the wheel surface, a probability density function is required to describe the surface roughness for all the grains engaged. Thus, the undeformed chip thickness 't' can be better described by Rayleigh's probability density function 'f(t)' [18] as;

$$f(t) = \frac{t}{\beta^2} \exp \left\{ -\frac{1}{2} \left(\frac{t}{\beta} \right)^2 \right\} \text{ for } t \geq 0 \tag{1}$$

$$= 0 \text{ for } t < 0$$

where β is a parameter that completely defines the probability density function and it depends upon the cutting conditions, the direction of grinding wheel and the properties of work piece materials. The expected value and the variance of the above function will be given as where β is a parameter that completely defines the probability density function and it depends upon the cutting conditions, the direction of grinding wheel and the properties of work piece materials. The expected value and the variance of the above function will be

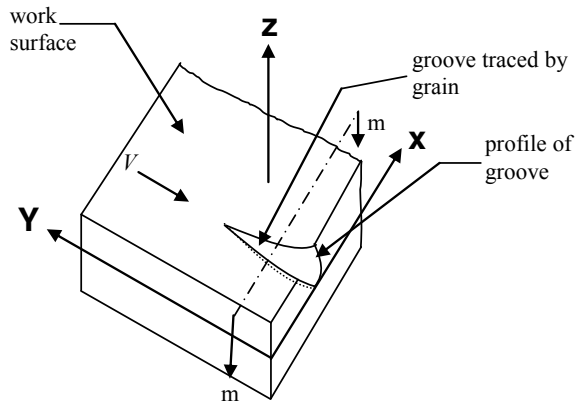

Fig. 1 Schematic view of the workpiece in cartesian coordinate system

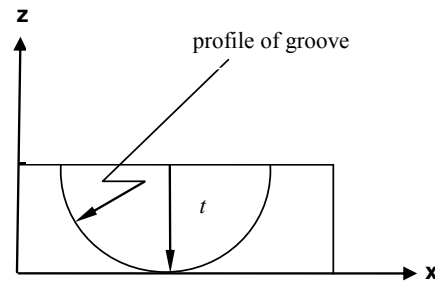

Fig. 2 Sectional view showing the shape of groove generated

given as

$$E(t) = \beta \sqrt{\pi/2} \text{ and } sd(t) = \beta \sqrt{(2 - \pi)/2}$$

The surface roughness R_a which is defined as the arithmetic average of the absolute values of the deviations of the surface profile height from the mean line within the sampling length l . R_a can be expressed as

$$R_a = \frac{1}{l} \int_0^l |y - y_{cl}| dl$$

where y_{cl} denotes the center line drawn in such a way that the areas above and below it are equal. It can also be expressed statistically as

$$R_a = \frac{1}{l} \int_{y_{min}}^{y_{max}} |y - y_{cl}| \cdot p(y) \cdot dy \tag{2}$$

where y_{max} and y_{min} are the lowest and highest peak height of the surface profile and $p(y)$ is the probability that height y of grain has a particular value y and may be expressed as

$$p(y) = \lim_{\Delta y \rightarrow 0} \frac{\text{probability}\{y - (1/2)\Delta y \leq y \leq y + (1/2)\Delta y\}}{\Delta y}$$

The surface roughness R_a can be calculated using probability density function defined in eq. (1). The complete description of surface generated is very difficult due to the complex behavior of different grains producing grooves because of the random grain-work interaction. Thus, certain assumptions have to be made while predicting the surface roughness. The assumptions are as:

- (1) The profile of the grooves generated is same and completely defined by the depth of engagement or undeformed chip thickness 't'
- (2) There is no groove overlapping
- (3) An individual grain has many tiny cutting points in its surface, therefore, for simplicity, the grains are approximated as uniform spheres of diameter d_g ($=2t$), randomly distributed throughout the wheel volume.

On the average, the expected value of an interference area through a sphere is about half of the area of a circle.

As per definition of surface roughness, the area above and below the centre line must be equal i.e. the total expected area can be written as

$$E\{A(t)\} = 0 \tag{3}$$

The above expression can be represented in terms of the probability density function $f(t)$ as

$$\int_0^\infty A(t).f(t).dt = 0 \tag{4}$$

There are two types of grooves generated depending upon their depth of engagement is either less or greater than centre line y_{cl} . For the case when the depth of engagement is less than y_{cl} can be expressed as

$$E\{A(t_1)\} = \int_0^{y_{cl}} A(t_1).f(t).dt, \tag{4a}$$

Similarly, for the groove with depth of engagement is greater than y_{cl} can be expressed as

$$E\{A(t_2)\} = \int_{y_{cl}}^\infty A(t_2).f(t).dt \tag{4b}$$

Substituting the values from eq. (4a) and (4b), in eq. (3), equation becomes

$$\int_0^{y_{cl}} A_1 f(t) dt + \int_{y_{cl}}^\infty (A_2^{upper} - A_2^{lower}) f(t) dt = 0 \tag{5}$$

$$\text{or, } p_1 E(A_1) + p_2 \{E(A_2^{upper}) - E(A_2^{lower})\} = 0 \tag{6}$$

where p_1 and p_2 are the probabilities defined in terms of the chip thickness probability density function $f(t)$ as

$$p_1 = \int_0^{y_{cl}} f(t) dt \quad \text{for } t < y_{cl} \tag{7}$$

$$p_2 = \int_{y_{cl}}^\infty f(t) dt \quad \text{for } t > y_{cl} \tag{8}$$

The expected area value, for the groove with depth less than centre line contributing to surface roughness R_a can be calculated as

$$E\{A(t_1)\} = 2 y_{cl} E(t_1) \frac{\pi}{2} E(t_1^2) \tag{9}$$

and the expected value of area, for the groove with depth greater than the centre line contributing to surface roughness R_a will be given as

$$E(A_2^{upper}) = 2y_{cl}E(t_2) - \frac{\pi}{2}E(t_2^2) + E\left\{t_2^2 \sin^{-1}\left(\frac{k}{t_2}\right)\right\} - E\left\{k\sqrt{(t_2^2 - k^2)}\right\} \tag{10}$$

$$E(A_2^{lower}) = E\left\{t_2^2 \sin^{-1}\left(\frac{k}{t_2}\right)\right\} - E\left\{k\sqrt{(t_2^2 - k^2)}\right\} \tag{11}$$

where $E(A_2^{lower})$ and $E(A_2^{upper})$ are the areas below and above the centre line as shown in Fig. 3. Rewriting the eq.(6) after substituting the expected values from eq. (9), (10), (11) as

$$2 y_{cl} \{p_1 E(t_1) + p_2 E(t_2)\} = \frac{\pi}{2} \{p_1 E(t_1^2) + p_2 E(t_2^2)\} \tag{12}$$

To calculate the expected values in the above equation requires another probability density function for the cases where the chip thickness is smaller and greater than the centre line y_{cl} . Thus, the conditional probability density function $f_1(t)$ and $f_2(t)$ defined for each region as

$$f_1(t) = f_1(t | 0 \leq t < y_{cl}) = f(t) / \int_0^{y_{cl}} f(t) dt \tag{13}$$

for chip thickness smaller than y_{cl} and for rest of the chip thickness

$$f_2(t) = f_2(t | y_{cl} \leq t < \infty) = f(t) / \int_{y_{cl}}^\infty f(t) dt \tag{14}$$

Substituting the eq. (7), (8), (13) and (14) in eq. (6) to find y_{cl} .

After simplification the expression for centre line can be expressed as

$$y_{cl} = \left(\frac{\pi}{4}\right) \left\{ \frac{E(t^2)}{E(t)} \right\} \tag{15}$$

substituting the expected values in the above equation, and after mathematical simplification, the value of the centre line will be

$$y_{cl} = \sqrt{\frac{\pi}{2}} \cdot \beta \tag{16}$$

For the calculation of the surface roughness, both types of grooves are required. Since the contribution of two types of grooves is different, thus, the total expected value of surface roughness can be calculated as;

$$E(R_a) = p_1 E(R_{a1}) + p_2 E(R_{a2}) \tag{17}$$

Where $E(R_{a1})$ and $E(R_{a2})$ are the expected value of the surface roughness for depth of engagement smaller or greater than y_{cl} . Thus, the values of the expected values can be calculated by the definition of the surface roughness according to which the surface roughness can be calculated by adding the area between the profile and the centre line and divide it by the total profile length. Hence from Fig. 3, the values can be written as

$$E(R_{a1}) = E\left(\frac{A_1}{2t_1}\right) \tag{18}$$

$$E(R_{a2}) = E\left(\frac{A_2^{upper} + A_2^{lower}}{2t_2}\right) \tag{19}$$

Rewriting the eq. (18) & (19) after substituting the expressions of A_1 , A_2^{upper} & A_2^{lower} from eq. (9), (10) and (11) as

$$E(R_{a1}) = y_{cl} - \left(\frac{\pi}{4}\right) E(t_1) \tag{20}$$

$$E(R_{a2}) = y_{cl} - \left(\frac{\pi}{4}\right) E(t_2) + E\left(R_2 \sin^{-1} \sqrt{1 - \left(\frac{y_{cl}^2}{t_2^2}\right)}\right) - y_{cl} \left(\sqrt{1 - \left(\frac{y_{cl}^2}{t_2^2}\right)}\right) \tag{21}$$

Substituting the expected values of $E(t_1)$, $E(t_2)$

$$E\left(R_2 \sin^{-1} \sqrt{1 - \frac{y_{cl}^2}{t_2^2}}\right) \text{ and } E\left(\sqrt{1 - \frac{y_{cl}^2}{t_2^2}}\right) \text{ from eq. (8),}$$

(10), (13) and (16) in eq. (20), (21) and then from eq. (17), the expected value of surface roughness can be expressed as

$$E(R_a) = 0.592 \beta \tag{22}$$

It can also expressed also in terms of the chip thickness expected value $E(t)$ by replacing β in terms of $E(t)$, as

$$E(R_a) = 0.471 E(t) \tag{23}$$

Eq.(23) shows a proportional relationship between the surface roughness and the chip thickness expected values under the assumption that the profile of groove generated by an individual grain to be a semicircular in shape and the phenomena like back transferring of material, grain overlapping are absent.

3. Prediction of surface roughness

The model has to be evaluated to determine its validity and versatility. The validity of the model is assessed through a comparison between the predicted value and measured value of the surface roughness within the predefined range of parameters. The versatility is based upon the usefulness of the model in predicting the kinematic conditions which would be required in order to produce specified surface finish. In order to compare the theoretical results obtained by making use of the model developed, experiments has been conducted in the horizontal surface grinding configuration. The work material taken was AISI 4340 steel with hardness 65HRC. The amount of material removed was the same for each experiment to maintain a consistent state of the wheel surface. The other conditions taken for experiment purpose are as follows; wheel speed 36.6 m/sec, wheel diameter 250 mm, wheel width 19 mm. The kinematic parameters for each experiment are depth of cut (a_e) and the speed ratio (v_s/v_w) where v_w (5, 10 and 15 m/min) is the feed rate and v_s is the wheel speed, as shown in table 1.

Exp.No.	1	2	3	4	5	6	7	8	9
a_e (μm)	5	5	5	10	10	10	15	15	15
v_s/v_w	440	220	146	440	220	146	440	220	146
R_a (μm)	.184	.271	.329	.206	.297	.367	.220	.331	.394

Table 1 Experimental Conditions

Surface roughness measurements were made using Talysurf-VI (cut-off length was 0.8mm) at five different places on the $20 \times 5\text{mm}^2$ cross-section of the workpiece after grinding and the arithmetic mean of the values of the measurements has been reported in the experimental results as shown in Table 1. The experiments are replicated five times (as shown in Table 1) to mask the variability of the process. By making use of the model of chip thickness developed in [16], the chip thickness expected value was calculated for each experiment.

To validate the model, the centre line average of surface roughness of all ground work pieces of the each set of experiment after a single pass was obtained using Talysurf-6 surface roughness measuring instrument. The results are

plotted along with the experiment values of the surface roughness as shown in Fig. 3. It can be easily observed that the predicted value of the surface roughness shows a good agreement with the experimental data obtained from the different kinematic conditions in horizontal surface grinding.

4. Results and discussion

The number of variables that influence the surface roughness of ground surfaces are numerous. These include the wheel, work and machine characteristics and the operating characteristics. Since the surface roughness model developed above is based on the chip thickness model which includes many parameters such as kinematic conditions, material properties etc. Therefore, this model can be used to calculate the surface roughness under different conditions of these parameters. The most common kinematic parameters are depth of cut and the speed ratio. Further the deviation of the surface roughness of the new models from the actual values, for various feeds and depth of cut is shown in Fig. 4. Typical results showing the effect of the grinding conditions on the surface roughness. It is seen that with increase in the values of feeds and depth of cut, surface-finish deteriorates. This is probably due to the forces generated at higher feeds and depth

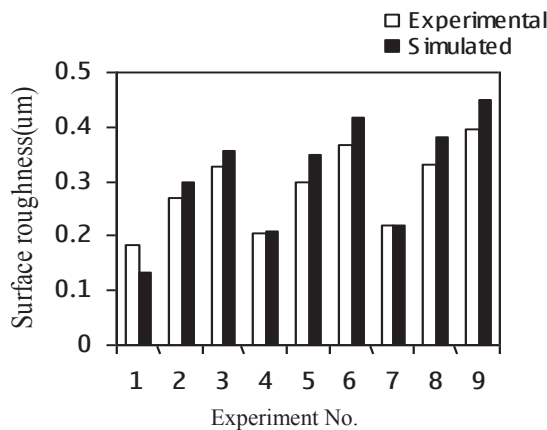

Fig. 3 R_a experimental and simulated values of surface roughness for surface grinding

of cut that results in higher deflections. Also, the value of surface roughness is slightly higher than the measured value for various values of feeds and depth of cut. The probable reason for this is the assumption that the profile of grooves generated is perfectly semi-circle which is not always the case. It can be observed from the Fig. 4 that the maximum deviation in the prediction of surface roughness with chip thickness model is about 1.15 times from the actual value. Another important parameter that will have significant effect on the surface roughness is the undeformed chip thickness. With increasing chip thickness, surface roughness will increase. Thus it appears that the chip thickness has pronounced effect causing a deterioration of surface finish. This

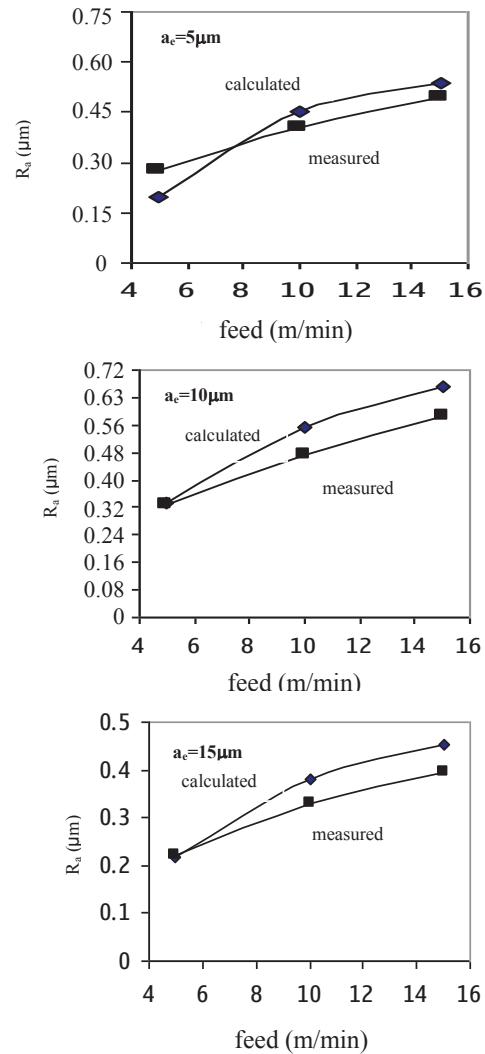

Fig. 4 Surface roughness presented against feed at various depths of cut

aspect is indicated by both theoretical and experimental results as shown in Fig. 3. Further, there appears to be reasonably close agreement between the experimental and simulated results.

5. Conclusion

In this paper, a simplified model is proposed for predicting the surface roughness of the work piece during the grinding process, taking into consideration the random distribution of the grain protrusion heights and assuming the profile of groove generated by an individual grain to be an arc of a circle. The model is based on the relationship between the variables of the surface roughness and the undeformed chip thickness. The variables like kinematic conditions, material

properties etc. are taken into considerations. The predicted surface roughness appears to yield results which agree reasonably well with the experimental values for different kinematic conditions in the horizontal surface grinding of AISI 4340 steel. Thus, the analytical model developed above proves to be a powerful and useful time efficient solution for the prediction of surface roughness.

References

- [1] Agarwal Sanjay, Rao PV. Grinding characteristics, material removal and damage formation mechanisms in high removal rate grinding of Silicon Carbide. *International Journal of Machine Tools and Manufacture* 2010; 1077–1087:50-12,
- [2] Agarwal Sanjay, Rao P V. Experimental Investigation of Surface/Subsurface Damage Formation and Material Removal Mechanisms in SiC Grinding. *International Journal of Machine Tools and Manufacture* 2008; 698-710:48-6.
- [3] Malkin, S. *Grinding Technology: Theory and Applications of Machining with Abrasives*, 1989 (Ellis Horwood, Chichester, West Sussex).
- [4] Suto, T, Sata, T. Simulation of grinding process based on wheel surface characteristics. *Bull. Jap. Soc. Prec. Engng*, 1981; 27-33: 15-1.
- [5] Sato, K. On the surface roughness in grinding technology. *Reports of Tokohu University*, 1955; 59-70: 20-1.
- [6] Orioka, T. Probabilistic treatment on the grinding geometry. *Bull. Japan Soc. Grinding Engrs*, 1961; 27-29.
- [7] Lal, GK, Shaw, MC. The role of grain tip radius in fine grinding. *Trans. ASME, J. Engng for Industry*. 1975; 1119-1125.
- [8] Tonshoff, H, Peters, J, Inasaki, I, Paul, T. Modeling and simulation of grinding processes. *Ann. CIRP*. 1992; 677-688: 41-2.
- [9] Zhou, X, Xi, F. Modeling and predicting surface roughness of the grinding process. *Int. J. Mach. Tools Mf.* 2002; 969-977:42.
- [10] Law, SS, Wu, SM. Simulation study of the grinding process. *Trans. ASME, J. Engng for Industry*. 1973; 972-978:95.
- [11] Hecker, RL, Liang, S. Predictive modeling of surface roughness in grinding. *Int. J. Mach. Tools Mf.* 2003; 755-761: 43.
- [12] Lal, GK, Shaw, MC. Wear of single abrasive grain in fine grinding. *Proc. Int. Grinding Conf.*, Carnegie-Mellon University, Pittsburgh, USA. 1972; 107.
- [13] Agarwal, S, Rao, PV. A probabilistic approach to predict surface roughness in ceramic grinding. *Int. J. Mach. Tools Mf.* 2005; 609-616: 45-6.
- [14] Agarwal, S, Rao, PV. A new surface roughness prediction model for ceramic grinding. *Proc. of IMechE, Part B, Journal of Engineering Manufacture*. 2005; 811-821: 219.
- [15] Agarwal, S, Rao, PV. Modeling and prediction of surface roughness in Ceramic Grinding. *International Journal of Machine Tools and Manufacture*. 2010; 1065–1076: 50-2.
- [16] Agarwal, S, Rao, PV. Predictive modeling of undeformed chip-thickness in ceramic grinding. *International Journal of Machine Tools and Manufacture*. 2012; 59-68: 56.