



Study of polypropylene surface modification by air dielectric barrier discharge operated at two different frequencies



K.G. Kostov^{a,*}, T.M.C. Nishime^a, L.R.O. Hein^b, A. Toth^c

^a Department of Physics and Chemistry, DFQ, Engineering Faculty in Guaratinguetá, FEG Universidade Estadual Paulista, UNESP, 12516-410, Guaratinguetá, SP, Brazil

^b Department of Materials and Technology, DMT, Engineering Faculty in Guaratinguetá, FEG Universidade Estadual Paulista, UNESP, 12516-410, Guaratinguetá, SP, Brazil

^c Research Centre for Natural Sciences, Institute of Materials and Environmental Chemistry, Hungarian Academy of Sciences, H-1025 Budapest, Hungary

ARTICLE INFO

Available online 2 October 2012

Keywords:

Dielectric barrier discharge
Plasma surface modification
Polypropylene
Surface morphology
Oxidation

ABSTRACT

In this work, air dielectric barrier discharge (DBD) operating at the line frequency (60 Hz) or at frequency of 17 kHz was used to improve the wetting properties of polypropylene (PP). The changes in the surface hydrophilicity were investigated by contact angle measurements. The plasma-induced chemical modifications of PP surface were studied by X-ray photoelectron spectroscopy (XPS) and Fourier-transformed infrared spectroscopy (FTIR). The polymer surface morphology and roughness before and after the DBD treatment were analyzed by atomic force microscopy (AFM). To compare the plasma treatment effect at different frequencies the variation of the contact angle is presented as a function of the deposited energy density. The results show that both DBD treatments led to formation of water-soluble low molecular weight oxidized material (LMWOM), which agglomerated into small mounts on the surface producing a complex globular structure. However, the 60 Hz DBD process produced higher amount of LMWOM on the PP surface comparing to the 17 kHz plasma treatment with the same energy dose. The hydrophilic LMWOM is weakly bounded to the surface and can be easily removed by polar solvents. After washing the DBD-treated samples in de-ionized water their surface roughness and oxygen content were reduced and the PP partially recovered its original wetting characteristics. This suggested that oxidation also occurred at deeper and more permanent levels of the PP samples. Comparing both DBD processes the 17 kHz treatment was found to be more efficient in introducing oxygen moieties on the surface and also in improving the PP wetting properties.

© 2012 Elsevier B.V. All rights reserved.

1. Introduction

Polypropylene (PP) is a common polymeric material frequently used in diverse industrial applications because of its excellent mechanical properties, lightweight, low cost and easy recyclability. Because of its non-polar nature and low surface energy the PP exhibits hydrophobic characteristics, which results in poor wettability, adhesion and printability [1,2]. However, many polymer applications require good adhesion properties, for instance in packing, coatings, lamination, painting, and printing in this way limiting the PP usage. Generally, the presence of polar groups and the surface morphology greatly influence the material wettability [2,3]. Therefore, different surface modification techniques were developed for improving the polymer adhesion properties. Recently, the classical, wet chemical technologies have been gradually replaced by the environmental friendly and low-cost plasma treatments, which can be conducted under low, medium or high-pressure conditions [2–4]. Since many industrial processes require a plasma technology that can be implemented in

continuous production line atmospheric pressure air plasmas have been widely employed [2,5,6]. Among them the dielectric barrier discharge (DBD) has attracted special attention due to the ability to produce large volume of non-thermal plasma and to its simple construction and safe operation [5–9].

DBD is characterized by the presence of at least one insulation layer in the discharge gap between two metal electrodes. When a high ac voltage (typically tens of kV in the frequency range of 50–10⁴ Hz) is applied to this configuration the gas breakdown occurs. In air the DBD normally operates in filamentary mode i.e. it is constituted by large number of tiny filaments distributed uniformly over the entire dielectric layer. Following the discussions in [10,11] the DBD can be characterized as non-thermal, weakly ionized plasma. The active plasma species, such as, UV photons, excited species and radicals react with the polymer surface and alter its surface energy [4]. Surface modification of polymers occurs through surface oxidation and scission as well as by surface roughening [12]. However, the incorporation of new functional groups at polymer surface by plasma has limitations due to the gradual surface degradation. Besides the oxygen incorporation on the surface through hydrogen abstraction, the plasma reactive species can also break C–C bonds

* Corresponding author. Tel.: +55 12 31232180; fax: +55 12 31232840.
E-mail address: kostov@feg.unesp.br (K.G. Kostov).

in the polymer chains. Thus, as the treatment proceeds, increasingly lighter oligomers are generated on the surface. Therefore, the prolonged exposure of polymers to oxygen containing plasmas leads to formation of low-molecular-weight oxidized material (LMWOM), which greatly affects the surface wettability, stability and adhesion properties [13]. These highly oxidized species tend to agglomerate into “bumps” or “mounds” like structures on surface [14]. The globular shapes are explained in terms of the difference in surface energy. Since the LMWOM has a higher surface tension than the naturally hydrophobic polymers the highly oxidized short polymer fragments formed during the plasma exposure would rather form a cohesive drop instead of spreading on the low-energy polymer surface [15]. Formation of these droplet-like structures basically depends upon the energy dose of the treatment and was observed by some authors using AFM analysis [15,16]. The LMWOMs are loosely bonded to the polymer and can be removed by rinsing with polar solvents [13–16]. However, the exact mechanism of LMWOM production and agglomeration at different plasma process parameters is not quite understood, yet.

The present study deals with surface modification of PP films by a filamentary air DBD operating at frequency of 60 Hz or 17 kHz. To promote surface modification of polymers DBD treatments in the kHz frequency range typically demand treatment time in the order of tens of seconds. Some studies reported that increasing the power supply frequency not only led to reduction of treatment time but also resulted in more efficient surface modification [17,18]. On the other hand plasma treatments at the line frequency usually require at least several minutes of exposure time. However, for some industrial applications a simple power source operating at the line frequency is more attractive, although longer processing time will be required. In this work, to evaluate the effect of the DBD process frequency on the PP surface modification the treatment intensity was expressed in terms of the energy dose, defined as the energy dissipated per unit area during the treatment period. To achieve a certain energy dose the duration of the 17.0 kHz DBD treatment scaled from couple of seconds up to 14 s while the treatment time of the 60 Hz DBD ranged from 1 to 15 min. As shown by some authors [18] the level of polymer surface modification is not only determined by the energy density of the process but also can be influenced by some other parameters, such as, the discharge regime or the type of working gas. In this work we have compared the PP modification at two different DBD frequencies varying the energy dose and maintaining the other process parameters fixed. The surface characteristics of PP before and after the plasma treatments were studied using contact angle measurements, atomic force microscopy (AFM), X-ray photoelectron spectroscopy (XPS) and infrared spectroscopy (FTIR) operated in the attenuated total reflection (ATR) mode.

2. Experimental setup

2.1. Plasma treatment

The experimental arrangement used to generate air DBD discharge at atmospheric pressure is sketched in Fig. 1.

The DBD discharge was generated between two 9.5-cm-diam parallel aluminum electrodes. Both reactor electrodes were covered by 2-mm-thick, 12-mm-diam, glass disks. The upper electrode was grounded and the lower one was employed as high-voltage electrode. For all DBD treatments the gas gap between the electrodes was fixed at 2.5 mm. Two different power sources were used in this study. A 60 Hz power supply consisted of a step-up high-voltage transformer (110/20,000 V) driven by an autotransformer Variac. During the experiments the high voltage applied to the reactor was set to 35 kV peak–peak while the treatment time was varied.

To induce DBD in the kHz range, a Minipuls4 generator from GBS Elektronik GmbH, Dresden, Germany was employed. Depending on

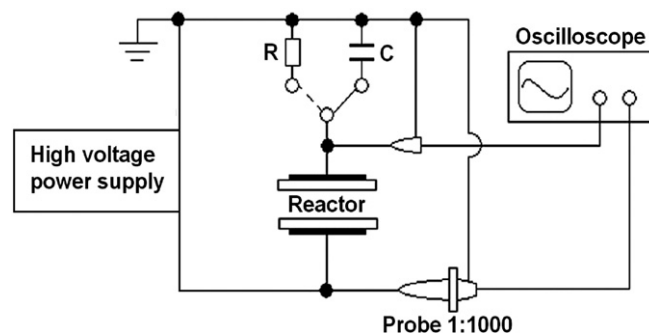

Fig. 1. Schematic drawing of the experimental setup.

the load it can provide sinusoidal voltages in the range 5–20 kHz and amplitudes up to 20 kV. In this work the operating frequency was fixed at 17 kHz because at this condition the signal amplitude delivered to the load was 18 kV, which closely approaches the peak-to-peak voltage magnitude of 35 kV applied during the low frequency DBD treatment.

The AC voltage applied to the reactor was measured by using a 1000:1 high-voltage probe (Tektronix P6015A, 75 MHz) and monitored on a digital oscilloscope (Tektronix TDS 2024B, 200 MHz). For displaying the waveform of the discharge current on the oscilloscope the reactor upper plate was grounded through a current measuring resistor of 10 Ω . The charge on the reactor plates was obtained from the voltage drop across a serial capacitor of 10 nF.

2.2. Materials

Before starting the plasma processing the samples (10 \times 15 mm), cut from a 0.3-mm-thick, additive-free PP polymer provided by Goodfellow, Brazil, were placed on the lower electrode. Prior to the DBD treatment, the samples were ultrasonically cleaned in distilled water and detergent for half an hour. To remove organic contaminants from the surface the specimens were washed by rinsing in isopropyl alcohol for 10 min and after that dried at room temperature. All plasma treatments were carried out in air at atmospheric pressure and ambient temperature. After the DBD treatment some samples were rinsed for 1 min in distilled water, air dried for 1 h and then subjected to further analysis.

2.3. Characterization techniques

The contact angle between a test liquid and the polymer surface was obtained by the sessile drop method on a standard Rame-Hart goniometer, model 300 using the DROImage software. The measurements were carried out at room temperature in controlled environment kept at relative humidity of 60%. The contact angle assessments were performed within 30 min after the treatments. The volume of each liquid drop was 2 μ l and de-ionized water was used as a test liquid. At least five different drops were deposited on the polymer surface to obtain the average value of the contact angles. The maximum error in the contact angle assessments did not exceed 3%.

Surface chemical composition of PP samples was analyzed by XPS and ATR–FTIR spectroscopy. XPS studies were performed by a Kratos XSAM 800 system, using Mg K_{α} radiation and fixed analyzer transmission mode (80 and 40 eV pass energies for the wide scan and detailed spectra, respectively). The spectra were referenced to the C 1s line (binding energy, BE = 285.0 eV) of the hydrocarbon type carbon. Data acquisition and processing were performed with the Kratos Vision 2 program. It is known that the surface chemical composition of plasma-treated polymers is not stable during first couple of weeks after the treatment and the O content usually tends to decrease.

Therefore, the XPS spectra of PP samples were obtained 2 weeks after the DBD process to ensure that the surface atomic composition has reached a steady state.

XPS analysis of PP was corroborated by FTIR spectroscopy, which was performed on a Perkin–Elmer Spectrum 100 system equipped with an ATR accessory. A diamond crystal was used as internal reflection element and the IR radiation incident angle was 45° . For each sample 32 scans with a resolution of 4 cm^{-1} were taken in the wavenumber range from 650 to 4000 cm^{-1} . The samples were analyzed half an hour after the DBD treatment.

Atomic Force Microscopy – AFM, was used to analyze surface morphology of the polymer samples. The AFM analysis was performed in air with a Shimadzu model SPM-9600 atomic force microscope. During the analysis, the microscope was operated in tapping mode with a scanning rate of 0.5 Hz for all scanning sizes using etched silicon probe ($k=50\text{ N/m}$). For each sample several images on area $10 \times 10\ \mu\text{m}^2$ were acquired at different locations. After that from the AFM topographic images the root mean square roughness (r_{rms}) was evaluated.

3. Experimental results

3.1. Plasma treatment

Both DBD treatments, at 60 Hz and 17 kHz , were conducted in air at atmospheric pressure and the discharges were operated in filamentary mode, i.e. they were constituted by many tiny microdischarges (filaments) randomly distributed over the entire area of the electrodes. Fig. 2(a–b) shows typical oscillograms of the applied voltage and the discharge current for both processes. As usual for

the filamentary DBDs the discharge currents in Fig. 2 are constituted by many tiny current peaks occurring during the rising or falling part of the voltage [6]. However, for the kHz frequency treatment shown in Fig. 2(b) the current peaks are superimposed on a relatively large capacitive current. Since the discharge power is consumed in many short living filamentary discharges it is not an easy task to determine the power dissipated in the DBD. A common method employed for calculating the discharge power is the so-called charge–voltage Lissajous figure, whose shape for DBD is typically a parallelogram [19]. The area of the closed loop for one period of applied voltage is equal to energy dissipated in one cycle. The mean discharge power is then simply the energy per cycle times the applied frequency. The corresponding Lissajous figures of the line frequency and the 17 kHz DBD treatments are shown in Fig. 3 exhibiting the typical shape of DBD operating in the filamentary regime.

As can be seen the area of the Lissajous figures corresponding to the different applied frequencies is quite distinct. Although the figure's area of the 17 kHz DBD is smaller (13 mJ) the average discharge power in this case is higher – 220 W . On the other hand the larger Lissajous figure of the DBD operated at 60 Hz (area of 59 mJ) corresponds to power of only 3.5 W . To evaluate the effect of DBD treatment at different process frequencies the treatment intensity was expressed in terms of the deposited energy density (discharge power multiplied to treatment time divided by the electrode area). Considering the average DBD powers calculated above an energy dose around 20 J/cm^2 can be achieved using 9.5 s DBD process at 17 kHz or by applying 10 min DBD treatment at 60 Hz . Therefore, the duration of the plasma exposure at 17.0 kHz DBD treatment scaled from couple of seconds up to 14 s while the treatment time for the 60 Hz DBD ranged from 1 to 15 min .

3.2. Surface chemical composition

The alteration of PP surface chemistry by the plasma was assessed by XPS and FTIR–ATR analysis. The untreated polymer contained only traces of O (about 2%) due to slight surface contamination and exhibited a narrow C 1s shown in Fig. 4(a). The C 1s peaks of PP samples treated at energy dose of 20 J/cm^2 but with different DBD frequencies are presented in Fig. 4(b–c). The broad shoulders on the high bonding energy side of these peaks suggests that C–O, C=O and COO– groups were introduced by the plasma.

The details of C 1s peaks decomposition for all PP samples are summarized in Table 1. Judging by the decomposition of the C 1s peaks it can be concluded that in each case the DBD treatment led to surface oxidation of PP. As shown in Table 1 the oxygen content of PP surface increases to 10% and 13% for the low and high frequency treatments, respectively. The oxygen can be added to the surface

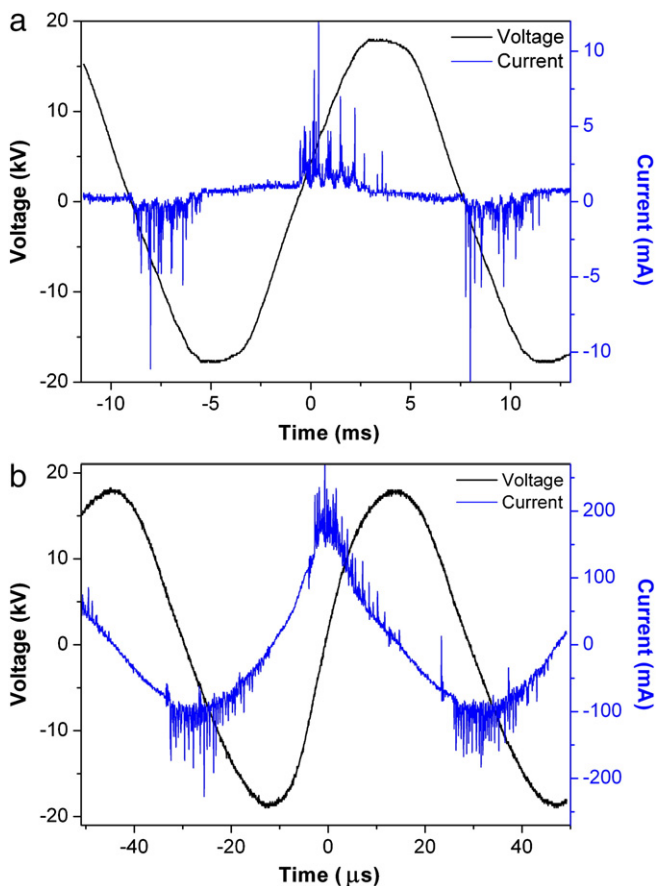

Fig. 2. Typical current and voltage waveforms for (a) 60 Hz and (b) for 17 kHz DBD.

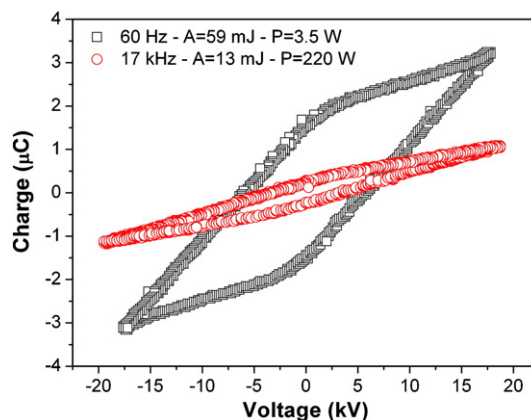

Fig. 3. Q–V Lissajous figures for both DBD processes.

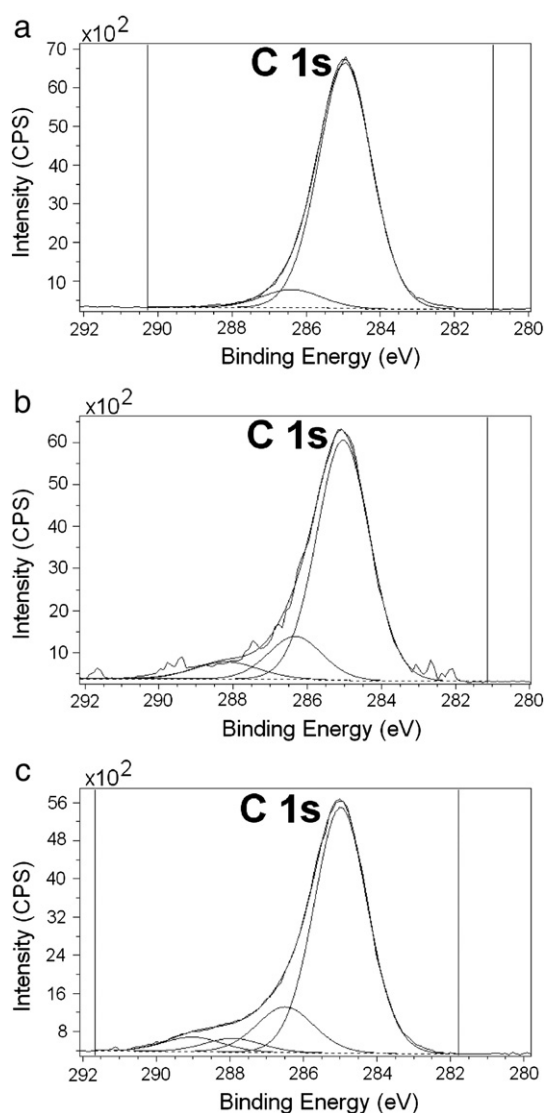

Fig. 4. Carbon C1s XPS spectra of (a) untreated PP and plasma-treated samples at 20 J/cm² with frequency of (b) 60 Hz and (c) 17 kHz.

during the plasma treatment and also by post-treatment reaction with oxygen from air with active radical created on the polymer surface by the DBD process (so-called auto-oxidation). Small amounts of N were also incorporated during the DBD treatment. This finding is an evidence for the incorporation of plasma species because the molecular nitrogen from air cannot easily attach to radicals on the polymer surface. Upon subsequent washing, the O-content of the DBD-treated samples always decreases as observed by other authors [20]. As can be seen in Table 1 the most oxidized C-components, C3 for PP, DBD-treated at low frequency and C4 for PP, DBD-treated at high frequency disappear after the washing. This suggests the

Table 1
Results of quantification of the XPS peaks (at.%).

	O	N	C4	C3	C2	C1
BE, eV			289.0	288.1 ± 0.3	286.4 ± 0.2	285.0
Bond type			O=C–O	C=O O–C–O	C–O	C–C C–H
Untreated	2				7	91
LF – unwashed	10			6	13	71
LF – washed	4	1		0	8	86
HF – unwashed	13	2	4	3	13	64
HF – washed	6	1	0	3	12	78

presence of soluble, low-molecular-weight oxidized compounds on the surface. After rinsing in water, the O-content of the treated samples still remains higher than that of the untreated surface, indicating that the oxidation also occurred at deeper and more permanent levels of the PP. The high frequency DBD treatment leads to more intense oxidation than the low frequency DBD treatment.

The reason for the slightly higher process efficiency at 17 kHz may be the more evenly distributed plasma in this case. Although both DBD operated in the filamentary mode, at high frequency the discharge was constituted by so many closely packed microdischarges so that it looked quite uniform. On the other hand, in the case of the line frequency DBD treatment single filaments can be easily discerned, probably leading to faster quenching of the atomic oxygen [8].

Further analysis of plasma chemical effect on the PP surface was conducted by infrared spectroscopy FTIR-ATR. Normally, surface functionalization of polyolefins is hardly detectable by ATR-FTIR because the plasma treatment modifies only the outmost (~few nm) layer of the polymer. However, in case of prolonged plasma treatments, when intense polymer degradation occurs, the FTIR analysis can detect the accumulation of LMWOM on the surface. Examples of the PP absorption spectra of DBD-treated samples are shown in Fig. 5(a–b).

The FTIR spectrum of a sample washed after the DBD treatment at 60 Hz in Fig. 5(a) is practically identical to the spectrum of untreated PP and exhibited only the typical PP bands, such as CH₂ and CH₃ stretching vibration modes (2820–2980 cm⁻¹), CH₃ symmetric and asymmetric bending modes (1373 and 1456 cm⁻¹, respectively) and vibration modes associated to the C–C bonding (1166–841 cm⁻¹ zone) [21]. After both DBD treatments (at 17 kHz and 60 Hz) the FTIR

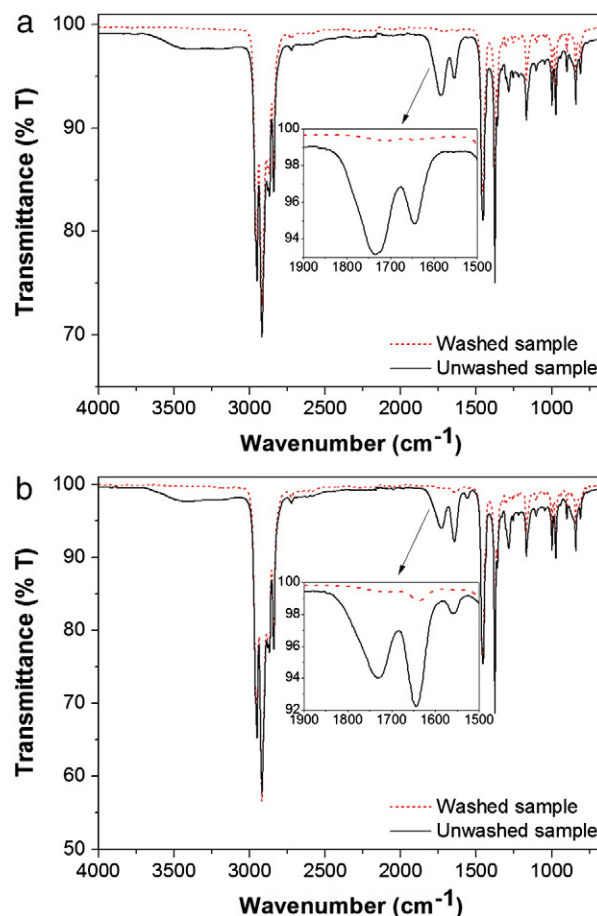

Fig. 5. FTIR spectra of PP treated at 60 Hz and 17 kHz DBD using the same energy dose of 20 J/cm² with discharge frequency of (a) 60 Hz and (b) 17 kHz.

spectra show some new features. Most important of them are found in the range of $1840\text{--}1600\text{ cm}^{-1}$ and indicate the existence of different kind of carbon–oxygen double bonds. The carbonyl groups presented in aldehydes, ketons and acids have strong absorption in the range of $1850\text{--}1650\text{ cm}^{-1}$. For example, the $\text{C}=\text{O}$ bonds in aldehyde and ketone usually have characteristic absorption bands at $1725\text{--}1740\text{ cm}^{-1}$ and 1715 cm^{-1} , respectively. The carboxylic acid COOH absorbs at 1760 cm^{-1} and its dimer in the range of $1720\text{--}1680\text{ cm}^{-1}$. Therefore, the absorption at 1640 cm^{-1} can be due to the carboxyl acid dimer or to terminal vinyl. The peak at 1280 cm^{-1} can be ascribed to COO –symmetric stretching vibration. The large absorption band between 3100 and 3670 cm^{-1} is attributed to the $\text{O}\text{--H}$ stretching vibration in alcohols and acids and also to absorbed water. Upon washing the DBD-treated samples the new absorption bands in the infrared spectra tend to disappear especially in the case of 60 Hz DBD process. However, the more detailed spectral examination (see the insets in Fig. 5a–b) reveals that some $\text{C}=\text{O}$ groups are still present on the washed sample surface leading to small absorption bands around 1710 and 1640 cm^{-1} . This observation is more evident in the spectrum of 17 kHz DBD process indicating more intense surface oxidation for this case as revealed by the XPS analysis. By summarizing, the FTIR spectroscopy indicates changes in the chemical structure of plasma-treated PP that are quite consistent with the results of XPS analysis and confirms that some oxygen containing groups remained on the polymer surface after the specimen washing.

3.3. Surface morphology

A series of AFM images of plasma-treated PP are presented in Fig. 6 together with an image of the pristine sample. The latter exhibits relatively smooth surface with several parallel trenches probably originated from the film manufacturing process. Several small indentation defects can also be noticed. As can be seen in Fig. 6(b) and Fig. 6(c), the DBD processing of PP resulted in formation of mount-like structures on the surface. The characteristic size of these structures grew with the treatment time increasing.

Both DBD treatments, at low and high frequencies, led to the formation of globular features however, the size of the structures formed at the 17 kHz DBD process was smaller than the granule dimension observed at the 60 Hz DBD with the same energy density.

The nodules observed in Fig. 6(b–c) are constituted by highly oxidized short polymer fragments, called in the literature low-molecular-weight oxidized materials (LMWOMs) [13,14]. These short oligomers behave like a viscous polar liquid and tend to de-wet the hydrophobic polymer surface forming the droplet structures in Fig. 6. However, the LMWOMs are loosely bonded to the polymer surface and can be easily removed by rinsing the samples in a polar solvent resulting in the change of the surface morphology and roughness. The images of the samples washed after the DBD treatment shown in Fig. 6 (d–e) present smoother surfaces without bumps. This finding is in accordance with the XPS and FTIR results, which showed that the surface oxygen content of PP samples decreased after washing. Therefore,

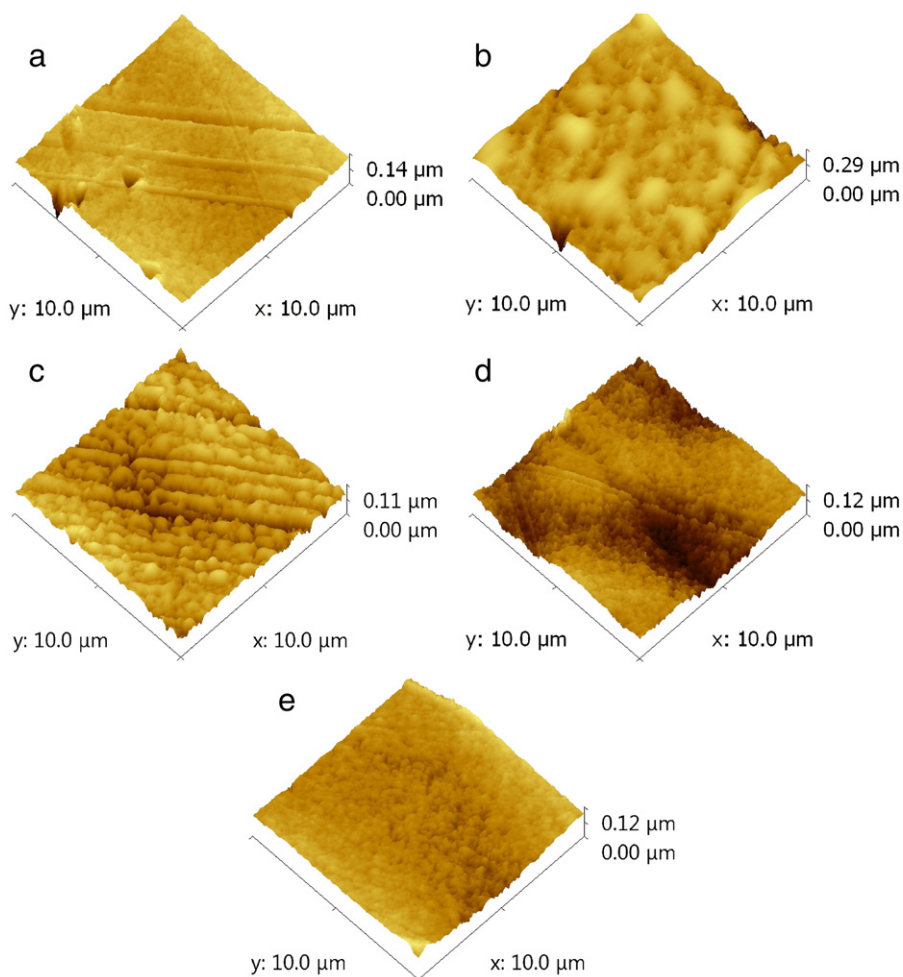

Fig. 6. AFM images of polypropylene samples: (a) untreated PP; (b) PP treated by low frequency DBD; (c) PP treated by high frequency DBD; (d) the same treatment as in item b) upon washing and (e) the same treatment as in item c) upon washing.

it is clear that the highly oxidized short polymer segments, generated by the plasma surface interaction, were concentrated into bumps on the PP samples and removed from the surface by the water rinsing.

The rms roughness of the as-treated PP samples together with the roughness of samples washed after the treatment is shown in Fig. 7 for different treatment intensities. As can be seen in this figure, in general for both treatment frequencies the PP roughness tends to increase linearly with the plasma exposure time due to the polymer surface degradation and the formation of LMWOM, which coalesced in nodule-like features [13,14]. The 60 Hz DBD process resulted in larger amount of LMWOM that agglomerated into bigger structures and correspondingly led to a rougher surface than the surface of the sample treated at 17 kHz. The surface of washed PP samples in Fig. 6(d and e) presents quite smooth surface with rms roughness close to the one of untreated sample. As can be seen in Fig. 7 the washed samples presented by open symbols in Fig. 7 have smaller roughness, which exhibits non-monotonic behavior with the increment of the treatment dose. Several other authors have also reported a similar roughness trend for the plasma-treated polymers [9,21]. Summarizing, the surface morphology and roughness of PP samples were greatly affected by the formation and removal of the water-soluble LMWOM.

3.4. Polymer wettability

The wettability of polymer indirectly indicates its susceptibility to molecular interaction with the liquid phase and the presence of polar groups on the surface. The measurements of the water contact angle for plasma-treated polymers with much LMWOM should be considered with caution. Still the WCA measurements can provide some qualitative information about the PP surface modification especially in the case when similar treatments are compared. The treatment of PP with plasma resulted in a decrease in the water contact angle. Fig. 8 shows the water contact angle (WCA) of DBD-treated PP samples as a function of the energy density for both treatment frequency at 60 Hz and 17 kHz. The improvement in surface wettability was obtained within a short time of plasma–polymer interaction (low energy density). This can be explained in terms of incorporation of new oxygen related functional groups on the surface as proved by XPS and FTIR analysis. However, the extension of the treatment time did not result in further improvement of polymer hydrophilicity and the WCA of plasma modified PP attained saturation value of around 65°.

The surface modification of polymers by plasma can be attributed to two processes: the incorporation of plasma species and formation of new functional groups on the surface and also gradual polymer degradation by hydrogen abstraction, formation of volatile products, sputtering and formation of low-molecular-weight products. In steady state, both processes occur simultaneously and lead to a

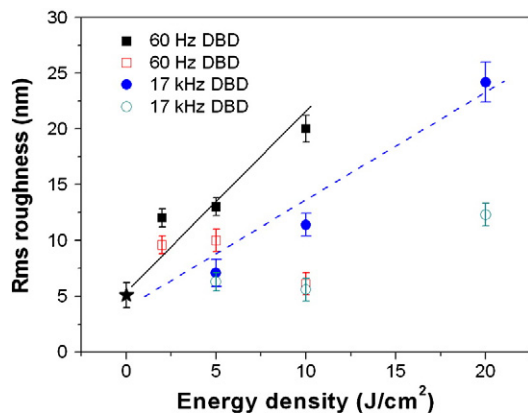

Fig. 7. Polypropylene rms roughness as a function of the treatment intensity. The open symbols represent the surface roughness upon washing.

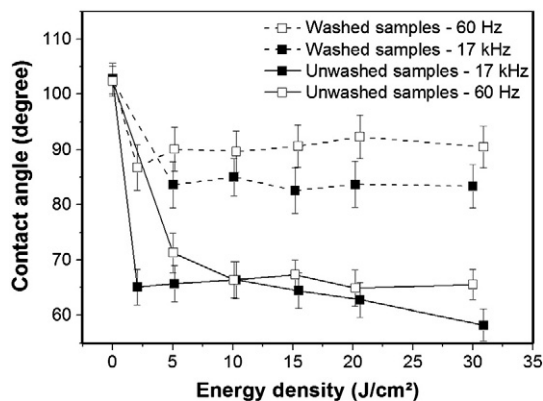

Fig. 8. WCAs of PP samples as a function of the energy density of the DBD process with and without subsequent washing.

modified layer of only few nm thickness. Therefore, after equilibrium between both processes is achieved, further increase of the treatment time does not result in changes of the polymer wettability. The major cause of this limitation is the plasma-induced polymer surface degradation and the formation of LMWOMs as evidenced by AFM. Within the measurement uncertainty the DBD treatment at 60 Hz and 17 kHz led to about the same reduction in the WCA.

For better comparison the WCAs of plasma treated PP samples upon washing are also depicted in Fig. 8. The removal of highly oxidized components from the PP surface, as evidenced by AFM, XPS and FTIR analysis, resulted in much modest improvement in the polymer wetting properties. One can also notice that the high-frequency DBD treatment seems to be a little bit more efficient with WCA around 85° in comparison with about 90° WCA for the 60 Hz DBD process. This finding is in agreement with the XPS measurements, which indicated more intense surface oxidation for the 17 kHz DBD treatment.

Besides the polymer degradation, which results in formation of LMWOM, another limitation of plasma modification process is the so-called surface hydrophobic recovery. When polymers treated by plasma are kept in ambient temperature and pressure conditions they usually partially recover their original wetting properties [13,22]. The recovery of material wetting characteristics is caused by the natural tendency of every thermodynamic system to reduce its surface energy. In case of the hydrophobic recovery of polymers several processes may simultaneously take place – reorientation of polymer chains so as the polar functional groups introduced on the surface by the plasma exposure are buried in the bulk of material, post-treatment interactions of surface radicals with air species, migration of non-polar groups from the bulk to the surface and diffusion of LMWOM towards the bulk of the material. This polymer surface instability can limit the advantages of the plasma treatment for some subsequent applications like coating or painting. In order to remedy the surface aging of plasma-treated polymers a lot of research has been performed, but a satisfactory solution has not been found, yet. However, there are some indications that there exists a relationship between the evolution of material wetting properties and the amount of LMWOM formed on the surface [23–25]. Therefore, to understand how polymer surface characteristics evolve with the time after the treatment, it is important to control the conditions of storage because they can directly influence the oxidized material formed on the surface.

After the plasma exposure the samples were stored in a controlled ambient at 22 °C and relative humidity of 40%. The evolution of polymer WCA can be observed in Fig. 9 for both DBD treatments. As can be seen all DBD-treated samples were subjected to hydrophobic recovery. However, the increase in WCA of the samples treated at 17 kHz was smaller, which is consistent with the lesser amount of LMWOM formed on the PP surface by this process.

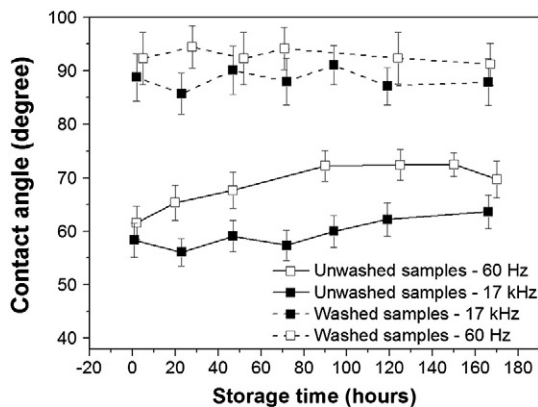

Fig. 9. Variation of PP wetting properties as function of the time after the treatment.

The WCA of treated and washed samples as a function of the storage time is also shown in Fig. 9. Although the WCA of the washed samples is higher (because the rinsing removes the LMWOM from the surface) as can be seen in Fig. 9 the PP surface is not subjected to hydrophobic recovery keeping practically constant its wetting properties for a period of one week. Thus one can conclude that in the case of DBD treatment of PP the accumulation of LMWOM on the surface plays an important role in the process of surface hydrophobic recovery.

The polymer aging behavior showed that the PP samples treated at higher frequency were less prone to hydrophobic recovery, which can be associated with the smaller amount of LMWOM formed on the surface. How to preserve the wetting properties of plasma-treated polymers is still an open question, however controlling the amount of LMWOM on the surface seems to be an important issue [23]. As reported in the literature the formation of LMWOM scales with the energy dose of plasma treatment [20,24], but it is also influenced by other factors, such as, the addition of water vapor, the usage of different discharge gases like N_2 and the sample storage conditions (pressure, temperature and humidity) [21,23,25]. Therefore, the detailed investigation of all factors that can affect the formation and the evolution of LMWOMs on the surface of plasma-treated polymers is crucial for controlling the process of surface hydrophobic recovery.

4. Conclusions

In this work, PP samples were treated by air DBD at atmospheric pressure using two different frequencies and the plasma-induced surface modifications in both processes were compared. The changes in polymer surface were governed by the surface oxidation and the formation of LMWOMs, which tended to agglomerate into nodule-like structures substantially affecting the surface roughness and wettability. However, as shown by XPS, FTIR and contact angle measurements the highly oxidized components were loosely bonded to the polymer surface and could be easily removed by rinsing. Although this process resulted in removal of most polar groups

from the PP surface the samples did not fully recover their original wetting characteristics. This finding indicates that oxidation also occurred in deeper and more permanent level of the polymer. Contrary to the as-treated polymer the treated and washed samples did not present hydrophobic recovery, which can be interesting for some applications.

Finally, the comparison of surface chemical composition and hydrophilicity for both DBD treatments showed that the 17 kHz DBD process was slightly more efficient in introduction oxygen atoms to the PP surface than the low frequency DBD. Also judging by the smaller size of the mount-like structures formed on the surface of PP samples treated by 17 kHz DBD less LMWOM was produced in this process. This finding may be explained by the fact that the 17 kHz DBD was constituted by larger number of filaments evenly distributed over the entire electrode area, which probably contributed for less oxygen quenching in the discharge.

Acknowledgments

The authors acknowledge the financial support from Conselho Nacional para Desenvolvimento Científico e Tecnológico – CNPq under the grant 507445/2010-4. Partial financial support from the National Scientific Research Fund (OTKA) and the National Development Agency (NFÜ), Hungary, through project K-67741 is acknowledged.

References

- [1] J. Balart, V. Fombuena, J.M. España, L. Sánchez-Nácher, R. Balart, *Mater. Des.* 33 (2010) 1.
- [2] J.F. Friedrich, P. Rohrer, W. Saur, Th. Gross, A. Lippitz, W. Unger, *Surf. Coat. Technol.* 59 (1993) 371.
- [3] W. Urbaniak-Domagala, *J. Appl. Polym. Sci.* 122 (2011) 2529.
- [4] R. Dogai, M.J. Kushner, *J. Phys. D: Appl. Phys.* 36 (2003) 666.
- [5] N. Encinas, J. Abenojar, M.A. Martínez, *Int. J. Adhes. Adhes.* 33 (2012) 1.
- [6] Ch. Wang, X. He, *Surf. Coat. Technol.* 201 (2006) 3377.
- [7] F. Leroux, C. Campagne, A. Perwuelz, L. Gendembre, *J. Colloid Interface Sci.* 328 (2008) 412.
- [8] Z. Fang, X. Xie, J. Li, H. Yang, Y. Qiu, E. Kuffel, *J. Phys. D: Appl. Phys.* 42 (2009) 085204.
- [9] O.J. Kwon, S. Tang, S.W. Myung, N. Lu, H.S. Choi, *Surf. Coat. Technol.* 192 (2005) 1.
- [10] N. Jidenko, E. Bourgeois, J.-P. Borra, *J. Phys. D: Appl. Phys.* 43 (2010) 295203.
- [11] U. Kogelschatz, *Plasma Chem. Plasma Process.* 23 (2003) 1.
- [12] G. Ma, B. Liu, C. Li, D. Huang, J. Sheng, *Appl. Surf. Sci.* 258 (2012) 2424.
- [13] S. Guimond, M.R. Wertheimer, *J. Appl. Polym. Sci.* 94 (2004) 1291.
- [14] N. Sellin, J.S.C. Campos, *Mater. Res.* 6 (2003) 163.
- [15] L.A. O'Hare, S. Leadley, B. Parbhoo, *Surf. Interface Anal.* 33 (2002) 335.
- [16] V. Jones, M. Strobel, M.J. Prokosch, *Plasma Processes Polym.* 2 (2005) 547.
- [17] J. Pichal, J. Sláma, *Probl. At. Sci. Technol.* 3 (2010) 188.
- [18] F. Massines, G. Gouda, N. Gherardi, M. Duran, E. Croquesel, *Plasma Polym.* 6 (2001) 35.
- [19] Z. Falkenstein, J.J. Coogan, *J. Phys. D: Appl. Phys.* 30 (1997) 817.
- [20] M. Strobel, C. Lyons, *J. Adhes. Sci. Technol.* 17 (2003) 15.
- [21] R. Morrent, N. De Geyter, C. Leys, L. Gengembre, E. Payen, *Surf. Interface Anal.* 40 (2008) 597.
- [22] N.Y. Cui, N.M.D. Brown, *Appl. Surf. Sci.* 189 (2002) 31.
- [23] M. Strobel, V. Jones, Ch.S. Lyons, M. Ulsh, M.J. Kushner, R. Dorai, M.C. Branch, *Plasma Polym.* 8 (2003) 61.
- [24] J. Song, U. Gunst, H.F. Arlinghaus, G. Julius Vansco, *Appl. Surf. Sci.* 252 (2007) 9489.
- [25] O. Mrad, J. Saunier, C. Aymes-Chodur, V. Mazel, V. Rosilio, F. Agnely, J. Vigneron, A. Etcheberry, N. Yagoubi, *Eur. Polym. J.* 47 (2011) 2403.