

GHGT-12

Octavius: Establishment of guidelines and standard operating procedures (SOPs) regarding sampling and analyses for the monitoring of pollutants emitted in CCS process liquid and atmospheric matrices

Isaline Fraboulet^{a*}, François Lestremau^a, Jean Poulleau^a, Hugues Biaudet^a, Ludovic Chahen^b

^aINERIS, Environment Characterization Department, Chronical Risk Division, Parc Technologique Alata, BP2, 60550 Verneuil-en-Halatte, France

^bIFPEN, Etablissement de Lyon, Rond-point de l'échangeur de Solaize - BP 3, 69360 Solaize - France

Abstract

Within OCTAVIUS EU FP7 SP1 subproject, a work package has been dedicated to the promotion of guidelines for the measurement of regulated pollutants (SO₂, NO_x, aldehydes, CO, CO₂, etc) and nitrogenous compounds (amines, nitrosamines, amides, etc) in the three matrices generated by CO₂ capture processes using amine based solvents i.e atmospheric emissions, wash water liquid wastes and circulating solvent. Processes of post combustion CO₂ capture using amine based solvents are indeed likely to generate, and emit, not only common pollutants, but also nitrogenous compounds whose effects on environment and human health may not be negligible. It is of primary importance to be able to measure those compounds using a reliable and accurate methodology. The guidelines have been delivered under the form of standard operating procedures (SOPs) which consist in recommendation in terms of sampling methods, samples storage, sample preparation and analyses. They are based on a review of existing standards, international literature and feedback from Octavius partners involved in such measurements, as well as evaluation tests performed on site and round robins on analytical methods.

© 2014 The Authors. Published by Elsevier Ltd. This is an open access article under the CC BY-NC-ND license (<http://creativecommons.org/licenses/by-nc-nd/3.0/>).

Peer-review under responsibility of the Organizing Committee of GHGT-12

Keywords: CCS matrices; emissions monitoring; regulated pollutants; nitrogenous compounds; nitrosamines; SOPs

* Corresponding author. Tel.: +33 344556334; fax: +33 344556302.

E-mail address: isaline.fraboulet@ineris.fr

1. Glossary

LOQ: limit of quantification

SOPs: standard operating procedures

CCS: CO₂ capture and storage

FTIR: Fourier Transformed Infra Red

GC-FID: Gas chromatography combined to Flame ionisation Detector

GC-MS: Gas chromatography combined to Mass spectrometry Detector

LC-MS: Liquid chromatography combined to Mass spectrometry Detector

LC/MS/MS: Liquid chromatography combined to Two Mass spectrometry Detectors used in Tandem

LC-MS-MS(QQ): Liquid chromatography combined to Two Mass spectrometry Detectors used in Tandem with triple quadrupole

PTRMS/PTRTOF-MS: *Proton-transfer-reaction mass spectrometry* / *Proton-transfer-reaction* Time of flight mass spectrometry

IMS: Ion mobility Spectrometry

NDIR Nondispersive infrared

TDLAS: Tunable diode Laser Absorption Spectroscopy

NDUV: Nondispersive ultra violet

TEA : Thermal Energy Analyser

NCD: Nitrogen Chemiluminescence detector

NDMA : N-nitrosodimethylamine

NMEA : N-nitrosomethylethylamine

NDEA : N-nitrosodiethylamine

NDPA : N-nitrosodipropylamine

NMOR : N-nitrosomorpholine

NPYR : N-nitrosopyrrolidine

NPIP : N-nitrosopiperidine

NDBA : N-nitrosodibutylamine

NDELA: N-nitrosodiethanolamine

tVOCs: total volatile organic compounds

2. Introduction

Processes of post combustion CO₂ capture using amine based solvents are likely to generate, and emit, not only common pollutants like SO₂, NO_x, CO, CO₂, aldehydes, etc) but also nitrogenous based compounds whose effects on environment and human health may not be negligible. Moreover, experiences from previous related studies such as the CASTOR[†] and CESAR[‡] programs have shown that the results from CCS emission measurements may be quite sensitive to the applied procedures of determination. As a result, it is of primary importance to be able to measure those compounds using a reliable and accurate methodology. This is particularly true when taking into account the specific issues and challenges associated to CCS matrices and the difficulty of measuring nitrogenous compounds in those matrices.

Within OCTAVIUS EU FP7 SP1 subproject, a work package has been dedicated to the promotion of guidelines for the measurement of regulated pollutants (SO₂, NO_x, aldehydes, CO, CO₂, etc) and nitrogenous compounds (amines, nitrosamines, amides, etc) in the three matrices generated by CO₂ capture processes using amine based solvents i.e atmospheric emissions, wash water liquid wastes and circulating solvent. Its aim is to provide recommendations under the form of Standard Operating Procedures (SOPs) for the measurement of regulated species (SO₂, NO_x,

[†] CASTOR CO₂, From Capture to Storage, FP6 project

[‡] CO₂ Enhanced Separation and Recovery, FP7 project

aldehydes, CO, CO₂, etc) and nitrogenous compounds (amines, nitrosamines, amides) in the three matrices generated by CO₂ capture processes using amine based solvent, to be used as a common methodology. SOPs are essential when carrying pollutants measurements in order:

- to make sure emissions measurements are carried out the same way when used by different laboratories ;
- to estimate the level of confidence that can be attributed to the monitoring methods used, and the results obtained.

A first step consisted of a brief assessment of existing knowledge amongst the literature, international standard methods and experiences acquired inside and outside the consortium from previous projects. Then, once gaps in knowledge identified, some developments of methods and evaluations have been performed in a second step. In a third step, the SOPs are proposed as a synthesis of the knowledge existing prior to the project and method development and evaluation work performed. The proposed paper presents the different steps that lead to the delivery of such SOPs.

3. The challenges of monitoring pollutants in CCS pilot plant matrices

The main challenges associated to the monitoring of pollutants in CCS pilot plant matrices are the following:

- the characteristics of the matrices make the sampling of some pollutants difficult;
- the levels at which the target pollutants are present and the lack of stability of some compounds;

3.1. Challenges associated to the matrices characteristics

Three types of matrices are considered in CCS emissions:

- the atmospheric matrix emitted at the chimney;
- the amine based solvent matrix used in the process;
- the wash water matrix;

The atmospheric matrix is a saturated flue gas characterized by a low temperature (25-50°C) and high moisture content which are penalizing conditions for sampling since they are causing risk of condensation of the pollutants if the temperature is not properly controlled. This risk of condensation can lead to measurements of artefacts. The amine based solvent matrix and the wash water matrix respectively contain around 5% and 30% of amines solvent which can enhance the lack of stability of nitrogenous target pollutants in samples and make their extractions difficult when performing analysis. As a result, the challenges concerning the atmospheric matrix mainly concern the sampling step whereas those associated to the wash water and solvent matrices are related to the analysis and more precisely the step of sample preparation.

3.2. Challenges associated to the levels of the target pollutants and the lack of stability of some compounds

The nitrogenous compounds are likely to exhibit thermal degradation if exposed to high temperature, degradation and formation by reaction with by products such as O₂, NO_x or acid gases, and degradation due to exposition to UV light. These reactions may lead to measurement of artifacts. This is particularly problematic if it leads to the in-situ-formation of nitrosamines. The measurement method used should address those issues, and should not generate alterations (degradation or artifact formation). This includes the sampling step as well as the storage, the sample preparation and the analytical steps.

4. Results

Three types of target species can be considered:

- the compounds which remain stable under the flue gas conditions such as SO₂, NO_x, aldehydes, CO, CO₂. For those compounds, standard methods for stationary combustion sources can be used;
- the compounds which do not remain stable under the flue gas conditions such as nitrogenous compounds (ammonia, amines, nitrosamines, amides, nitramines). For those compounds, specific approaches that enable to eliminate and control the risk of degradations and side reactions have to be applied;
- the gas flow to be sampled which includes dust, droplets and aerosols. Sampling aerosol under such conditions of moisture and temperature of the flue gas can be quite challenging due to the risk of condensation, evaporation, size distribution modification that may arise when sampling. Since the knowledge available, the literature and the feedback within the partners of the Octavius program remained quite limited on this point, no SOPs has been proposed on aerosol measurements from CCS atmospheric emissions.

4.1. Guidelines regarding sampling and measurements of atmospheric emissions

Requirements for the collection of representative samples from atmospheric emissions are described in a dedicated standard numbered EN 15259. CCS processes pilot plants are not specifically designed for emissions measurement studies, as a result, their design and the scale of the facilities, may not comply with those requirements. This can cause risk of flue gas stratification and lack of homogeneity of the flue gas i.e lack of representativeness of the samples collected. Moreover, the space, available in the facilities to perform samplings, may not allow performing proper flue gas homogeneity test measurements such as defined in this standard. These two aspects have to be considered in order to reach a compromise between best practices such as described in the EN 15219 standard, and real on-site practices according to facilities characteristics.

4.1.1. Measurement of stable compounds in CCS pilot plant atmospheric emissions

For most stable compounds (SO₂, NO_x, aldehydes, CO, CO₂, etc), reference methods can be applied; although since the flue gas is saturated with moisture, a particulate attention is necessary to avoid condensation of target pollutants during sampling. The general sampling approach for those compounds is presented in . It consists of a heated sampling probe connected to a heated filter for the collection of the particulate phase, at the outlet of the filter a derivation can be applied to simultaneously perform measurements of gaseous species in absorption solutions, on cartridges or using a gas analyser. The samples are collected under isokinetic conditions to take into account the components dissolved in droplets. The standard methods used for the different regulated pollutants are presented in Table 1.

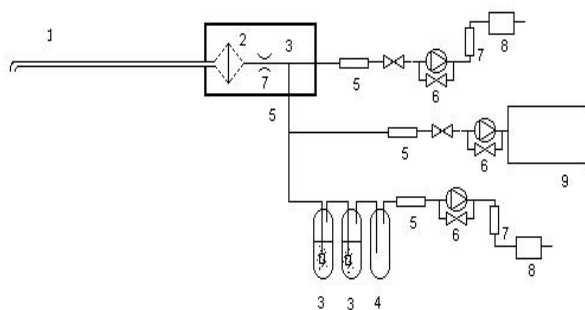

Figure 1: Schematic of the general sampling approach for stable compounds

- 1 heated sampling probe (glass, teflon)**
- 2 heated particle filter (instack or outstack)**
- 3 absorber(s)**
- 4 back-up impinger (optional)**
- 5 cartridge with desiccant (optional)**
- 6 pump**
- 7 flow meter behind the filter (e.g. diaphragm) or before the gas meter**
- 8 gas meter**
- 9 online measurement method**

The standard methods based on the sampling train presented above and used for the different regulated pollutants are presented in Table 1.

Table 1: Recommended standard methods for the measurement of stable regulated compounds in the atmospheric matrix

Compound	Method description	Standard	Alternative methods
CO/CO ₂	Use of an automatic analyser using Infra-Red (IR) absorption principle.	EN 15058	FTIR with a heated line
NH ₃	Sampling according to EN 13284-1, 2 washing bottles filled in with sulfuric acid placed at the outlet of the filter Analysis of the filter and the washing bottles using Ion Chromatography or molecular absorption spectrophotometry	NF X 43-303 JIS K099	Analysis using: GC-MS after derivatization for gas and liquids LC-MS for liquids Measurements using: PTRMS/PTRTOF-MS hot NDIR or FTIR with a heated line Tunable diode Laser Absorption Spectroscopy (TDLAS)
NO _x	Automatic method based on the chemiluminescence principle	EN 14792	FTIR with a heated line Tunable diode Laser Absorption Spectroscopy (TDLAS) UV or IR absorption
Aldehydes/ Ketones	Gaseous and particulate pollutants are sampled according to EN 13284-1, solution of aqueous acidic 2,4-dinitrophenylhydrazine placed at the outlet of the filter. Aldehydes react with the 2,4-dinitrophenylhydrazine to form the aldehyde dinitrophenylhydrazone derivative Analysis using HPLC/UV	California EPA method 430 / US EPA 0011 placed at the outlet of the filter of the EN13284-1	Analysis using: LC/MS/MS Measurement using: PTRMS/PTRTOF-MS
O ₂ *	Automatic method based on the paramagnetic principle (0 to 21% O ₂)	EN 14789	
SO ₂	Sampling according to EN 13284-1, solution of water placed at the outlet of the filter. Analysis using Ion Chromatography or Thorin method	EN 14791 US EPA 6	hot NDIR or FTIR with a heated line NDUV
Hg	Sampling according to EN 13284-1, 3 washing bottles filled with a mixture of HNO ₃ 20% m/m and K ₂ Cr ₂ O ₇ 4%	EN 13211	
Heavy metals	Sampling according to EN 13284-1, 3 washing bottles filled with a mixture of w(HNO ₃) ≈ 3.3 % and w(H ₂ O ₂) ≈ 1,5 %. Analysis using ICP-MS or ICP-OES	EN 14385	
tVOCs	Automatic method based on combustion of VOC in a H ₂ or H ₂ /He flame with a detector of flame ionization (FID)	EN 12619	FTIR with a heated line

*determination necessary to express the levels of concentration according to a standard level of O₂

4.1.2. Main recommendations for general sampling train for the collection of unstable compounds in CCS pilot plant atmospheric emissions

The sampling system and procedures used for the collection of atmospheric emissions shall not generate alterations (degradation or artifact formation) of the target compounds. Thermal instability of nitrogenous compounds in a gas saturated with water vapor requires the use of dedicated strategies to avoid and control degradation reactions and to properly monitor the amount of the species that may degrade or that may be produced by these degradation reactions. The standardized methods when they exist have to be adapted.

More precisely, the following recommendations should be followed (SINTEF 2010):

- the dilution of the flue gas should be avoided,
- the use of sampling heated lines should be avoided for the compounds that may degrade
- avoid adsorbents or absorbents that may lead to an effect on the compounds to be measured (during desorption for example)

It is also recommended to simultaneously and appropriately sample the different phases (CSIRO 2010).

The proposed sample strategy (SINTEF 2010 a) consists of an isokinetic sampling train with a sampling probe heated at flue gas temperature and impingers placed in an ice bath. A minimum velocity of 82-93 m/s at the impinger nozzle is required, in order to fulfill collection efficiency above 95% of 1.4-1.5 μm diameter droplets in the first impinger. The condensate is collected in impingers protected from light with aluminium foil and can be analyzed. A very short sample tube between the nozzle opening and the sample capture device minimizes contact of the target species with the wetted surface area of the probe. If necessary, reagents can be added to the impinger solution to preserve specific compounds. In the case of nitrosamines sampling for example, a sulfamic acid solution at 0.1 mol/l is used to avoid side reactions. It is recommended to adapt the flow rate and the duration of sampling in order to maximize the volume of gas samples, and as a result obtain LOQ per cubic meter as low as possible.

The main advantages of this sampling method are the fact that the sample is not disturbed (no evaporation, heating or filtration) before absorption, the thermal degradation and side reactions are avoided, which limits measurement artifacts, and the sampling is relatively easy to perform. On the other hand, the use of this method requires the determination of collection efficiency. Another disadvantage of this method concerns the risk of condensation of the target compounds in the sample probe and lines which need to be cleaned or changed between samplings to avoid sample contamination. The contribution of losses in the sampling probe due to condensation needs to be evaluated.

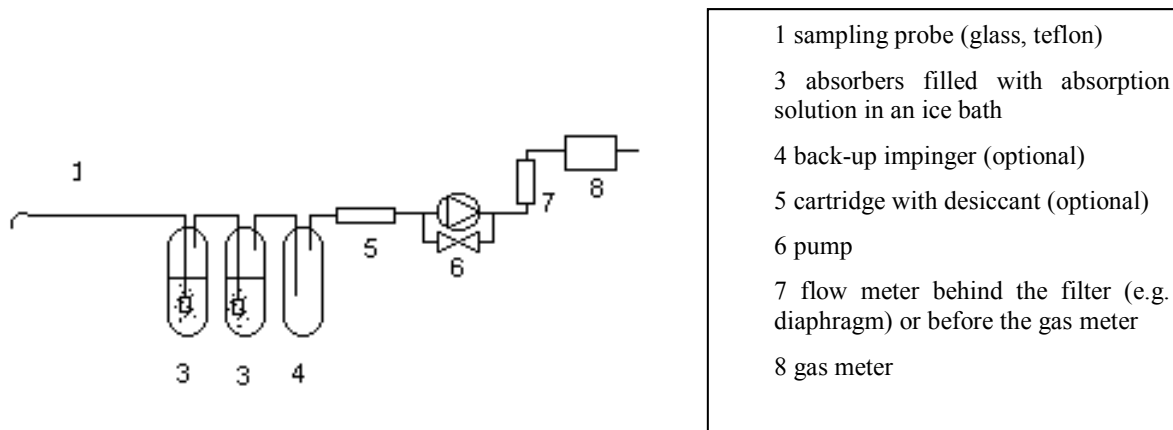

Figure 2 : Schematic of the general sampling approach for unstable compounds

The proposed method has been evaluated on real pilot emissions. First, the contribution probe to the total concentration of NDMA determined from a pilot plant emissions using this sampling train has been determined by rinsing the probe and analyzing the rinsing solution. It lead to concentrations below the LOQ of 1 ng/volume of the rinsing solution. This result indicates that, for the samples collected, the contribution of losses in the probe was negligible for a volatile nitrosamine like NDMA. Secondly, in order to determine the collection efficiency of the two impingers, a separate analysis of the second impinger has been performed. The contribution of the concentration in comparison with the total concentration has been determined. The calculation based on the results of analyses of NDMA of the second impinger leads to an average contribution of 19%. As a comparison in standardized methods, the requirement is a contribution of the concentration in the second washing bottle not higher than 5% of the total concentration determined (eg. NF X 43-304 for HF and EN 14791 for SO₂). Although this can be considered as acceptable, an improvement of the method may be to add a third impinger of sulfamic acid to the sampling train. These results would need to be confirmed by carrying more trials on other pilot plants; moreover, for less volatile species like NDELA which was not measured during those trials, no final conclusions can be drawn based on these results.

4.1.3. Recommendations in terms of sample storage

Sample preservation is challenging because of the limited knowledge about interferences between individual compounds and degradation due to UV (natural radiation) and exposure to air. Therefore, preservation of samples requires special care. Some results (SINTEF 2011) indicate that the most important parameter in terms of samples stability is UV light exposure; temperature and duration of storage seem to have a limited impact on the stability of the samples. However, those tests were performed with nitrosamines in water matrix only and at high levels of concentration (2 mg/l). More results of stability tests for nitrosamines in solvent matrices and at low concentrations would be necessary to conclude on this point.

The following procedures are appropriate:

- air and liquid tight sealing of containers.
- storage at reduced temperatures (refrigerator, freezer according to the analyte) in a refrigerated environment protected from UV-light.

For all kind of samples, it is recommended to perform analysis as early as possible, ideally within a week after sampling.

4.1.4. Guideline regarding the analysis of unstable compounds

- General guidelines (CSIRO 2010, SINTEF 2010b)

During sample preparation, the temperature of the sample should be kept low whenever possible and exposure to light should be minimized. In addition, the sample preparation procedures should be minimized regarding the number of steps / duration of the procedure. If possible, the sample should not be exposed to extreme pH conditions or other strong reagents that may interfere with the result of the analysis. When possible, extractions should be avoided, and dilution or direct injection should be preferred because it causes minimal interference with the sample and is a very simple and cost-effective way to prepare a large number of samples. However, in order to reach low quantification limits, concentration steps may be necessary. In that case, extra care needs to be taken to avoid unwanted chemical reactions during sample preparation. A relevant example is the possible reaction between nitrite and secondary amines that form nitrosamines as an artifact. It must be controlled and verified that no degradation or unwanted chemical reactions takes place during the whole sample preparation process and analysis.

• Methods review

The following table presents the recommended methods for the analysis of unstable nitrogenous compounds in CCS processes matrices. Alternative methods, when they exist, are also mentioned. The characteristics of these alternative methods has been studied (Mertens et al, 2012; Mertens and Faniel, 2014, SINTEF, 2010), but they have not necessarily been compared to the recommended methods.

Table 2: Recommended methods for the analysis of unstable nitrogenous compounds in CC S processes matrices

Compound	Description of the recommended methods (SINTEF 2010 b, SINTEF 2011, Ramboll 2010, Ramboll 2011) ,	Standard	Alternative method
Amines	<p><u>Atmospheric emissions matrix:</u> ion chromatography LC-MS, MS can be performed by single quadrupole (MS-SQ) or preferably with triple quadripole technology (MS-QQQ), direct injection</p>	-	<p>-Analysis using : GC-MS for gas and liquids or LC-MS for liquids - OSHA methods 34, 36, 40, and 41, 60, PV2018, PV 2111, PV 2145 (amines in ambient air) could be used in combination with a condensate analysis by LC-MS or ion chromatography -Measurement with PTRMS/PTRTOF-MS used directly with a heated sampling line (risk of degradation and measurements artefacts in the heated line) or behind a cooling sampling which implies a combined analysis of condensates by LC/MS or GC/MS (SINTEF, 2010) - Measurement with IMS used directly with a heated sampling line (risk of degradation and measurements artefacts in the heated line) or used behind a cooling sampling which implies a combined analysis of condensates by LC/MS or GC/MS (SINTEF, 2010) -Measurement with FTIR with a heated line (risk of degradation and measurements artefacts in the heated line) (Mertens et al, 2012; Mertens and Faniel, 2014, SINTEF, 2010)</p>
	<p><u>Liquid matrices</u> LC-MS, MS performed by single quadrupole (MS-SQ) or preferably with triple quadrupole technology (MS-QQQ). Direction injection for wash water samples Dilution before injection for solvent amines samples</p>		

Compound	Description of the recommended methods (SINTEF 2010 b, SINTEF 2011, Ramboll 2010, Ramboll 2011) ,	Standard	Alternative method
Alkylamines	<p><u>Atmospheric emissions matrix:</u> Derivatization step using NDB chloride followed by GC/MS low-molecular weight compounds and LC-MS high-molecular weight compounds</p>		<p>-Direct analysis using GC- FID or GC-MS but poor detection limits or LC-MS but poor detection limits for low-molecular weight compounds -OSHA methods 34, 36, 40, and 41 could be used in combination with a condensate analysis by LC-MS or GC-MS -Measurement with PTRMS/PTRTOF-MS used directly with a heated sampling line (risk of degradation and measurements artefacts in the heated line) or behind a cooling sampling which implies a combined analysis of condensates by LC/MS or GC/MS (SINTEF, 2010) - Measurement with IMS used directly with a heated sampling line (risk of degradation and measurements artefacts in the heated line) or used behind a cooling sampling which implies a combined analysis of condensates by LC/MS or GC/MS (SINTEF, 2010)</p>
	<p><u>Liquid matrices</u> Derivatization step using NDB chloride followed by GC/MS low-molecular weight compounds and LC-MS high-molecular weight compounds</p>		

Compound	Description of the recommended methods (SINTEF 2010 b, SINTEF 2011, Ramboll 2010, Ramboll 2011) ,	Standard	Alternative method
Amides	<u>Atmospheric emissions matrix:</u> LC-MS QQQ, direct injection		-GC- FID or GC-MS but poor detection limits or LC-MS but poor detection limits for low-molecular weight compounds -OSHA method 2084 (amides in ambient air matrix) could be used in combination with a condensate analysis using LC-MS or GC-MS -PTRMS/PTRTOF-MS used directly with a heated sampling line (risk of degradation and measurements artefacts in the heated line) or behind a cooling sampling which implies a combined analysis of condensates by LC/MS or GC/MS (SINTEF, 2010) -IMS used directly with a heated sampling line (risk of degradation and measurements artefacts in the heated line) or used behind a cooling sampling which implies a combined analysis of condensates by LC/MS or GC/MS (SINTEF, 2010)
	<u>Liquid matrices:</u> LC-MS QQQ, direct injection		

Compound	Description of the recommended methods (SINTEF 2010 b, SINTEF 2011, Ramboll 2010, Ramboll 2011) ,	Standard	Alternative method
Specific Nitrosamines (NDMA, NMEA, NDEA, NDPA, NMOR, NPYR, NPIP, NDBA, NDELA)	<u>Atmospheric emissions matrix:</u> -samples diluted and analyzed without any further pretreatment, analysis using (LC-MS-MS(QQQ)). -samples pretreated with SPE to extract and concentrate nitrosamines in the extract, analysis using GC-MS-MS ion trap or GC-HRMS for volatile nitrosamines (except NDELA). -liquid liquid extraction (LLE) , GC-TEA for NDMA and NMOR, GC-TEA cation exchange and derivatization for NDELA -liquid liquid extraction (LLE) for all nitrosamines except NDELA, continuous liquid liquid extraction (CLLE) for NDELA, to extract and concentrate nitrosamines in the extract, analysis using GC-HRMS for all nitrosamines except NDELA, UPLC-MS-MS for NDELA	US EPA 521	-
	<u>Liquid matrices</u> -samples diluted and analyzed without any further pretreatment, analysis using (LC-MS-MS(QQQ)). -samples pretreated with SPE to extract and concentrate nitrosamines in the extract, analysis using GC-MS-MS ion trap for all nitrosamines except NDELA. -liquid liquid extraction (LLE) , GC-TEA for NDMA and NMOR, GC-TEA cation exchange and derivatization for NDELA -samples pretreated with SPE to extract and concentrate nitrosamines in the extract, analysis using GC-HRMS for NDMA and NMOR and LC-MS-MS for NDELA -liquid liquid extraction (LLE) for all nitrosamines except NDELA, continuous liquid liquid extraction (CLLE) for NDELA, to extract and concentrate nitrosamines in the extract, analysis using GC-HRMS for all nitrosamines except NDELA, UPLC-MS/MS for NDELA	ISO 15819: 2008	-
Total nitrosamines	- Chemical denitrosation and subsequent chemiluminescence detection. Total nitrosamines measured as released NO gas (from the nitroso group of the nitrosamine) by TEA (NCD) after treatment of the sample with CuCl and HCl (Wang. et al. 2005) -Chemical denitrosation and subsequent chemiluminescence detection. Total nitrosamines measured as released NO gas (from the nitroso group of the nitrosamine) by TEA (NCD) after addition to the samples of HBr/Glacial acetic acid/Ethyl acetate and boiling of the mixture at 80 °C (Frischmann, 2011)	-	-

Round robin tests have been organized, on solvent samples and atmospheric emission samples collected using the sampling train described in Figure 2, to test the comparability of those methods. This work will be presented later on.

5. Conclusions

The work carried out in this review allowed pointing the challenges of measuring nitrogenous unstable compounds emitted from CCS matrices. Although the measurement of stable regulated compounds can be performed by applying standard methods while taking into account the fact that the flue gas is saturated, the measurement of nitrogenous compounds requires specific attention.

On the one hand, due to the fact that the flue gas is saturated, the sampling step is particularly critical when characterizing atmospheric emissions. On the other hand, the analytical step and more precisely the preparation step aiming at determining nitrogenous compounds, is made difficult by the liquid matrices which are characterized with a high level of amines (5% to 30%). Guidelines have been formulated in order to provide a representative determination of these compounds and to avoid any alteration of the samples along the process of determination. Regarding unstable nitrogenous compounds, the main conclusions are as follows:

- for atmospheric emission, an isokinetic sampling method with a sampling probe heated at flue gas temperature and impingers placed in an ice bath is recommended. If necessary, like in the case of nitrosamines, reagents such as sulfamic acid can be added to the impinger solution to preserve specific compounds;
- samples should be stored, in air and liquid tightly sealed containers in refrigerated environment and protected from UV-light;
- analyses of the samples should be performed as early as possible, ideally within a week after sampling;
- during sample preparation, the temperature of the sample should be kept low whenever possible and exposure to light should be minimized. In addition, the sample preparation procedures should be minimized regarding the number of steps / duration of the procedure. When concentration steps are necessary, extra care needs to be taken to avoid unwanted chemical reactions during sample preparation.

Several analytical methods have been proposed, and their results compared by carrying out round robin tests whose results will be presented later on.

6. Acknowledgements

This work has been performed within the FP7 project OCTAVIUS (Grant Agreement n° 295645). The authors thank the Octavius partners for their contribution to this work by their feedback and expertise.

7. References

7.1. Standard methods

California EPA Method 430 Determination of Formaldehyde and Acetaldehyde in Emissions from Stationary Sources, 1991

EN 12619 :2013 Stationary source emissions. Determination of the mass concentration of total gaseous organic carbon. Continuous flame ionisation detector method

EN 13211: 2001 Air quality. Stationary source emissions. Manual method of determination of the concentration of total mercury

EN 13284-1 :2002 Stationary source emissions. Determination of low range mass concentration of dust. Manual gravimetric method

EN 14385 Stationary source emissions Determination of the total emission of As, Cd, Cr, Co, Cu, Mn, Ni, Pb, Sb, Tl and V

EN 14789: 2005 Stationary source emissions. Determination of volume concentration of oxygen (O₂). Reference method. Paramagnetism

EN 14791 : 2005 Stationary source emissions. Determination of mass concentration of sulphur dioxide. Reference method

EN 14792: 2005 Stationary source emissions. Determination of mass concentration of nitrogen oxides (NO_x). Reference method: Chemiluminescence

EN 15058:2006 Stationary source emissions. Determination of the mass concentration of carbon monoxide (CO). Reference method: non-dispersive infrared spectrometry

EN15259 EN 15259:2007, Air quality. Measurement of stationary source emissions. Requirements for measurement sections and sites and for the measurement objective, plan and report

ISO 15819: 2008 Cosmetics. Analytical methods. Nitrosamines. Detection and determination of N-nitrosodiethanolamine (NDELA) in cosmetics by HPLC-MS-MS

Japanese Standards Association JIS K099 Impinger-Boric acid solution , spectrophotometry and IC analysis for the determination of ammonia emissions

Method PV2018, Sampling and analysis of diethanolamine using NITC coated XAD-2 tube+HPLC/UV analysis

Method PV 2111, Sampling and analysis of ethanolamine using NITC coated XAD-2 tube+HPLC/UV analysis

Method PV 2145 Sampling and analysis of 2-amino-2-methyl-1-propanol using NITC coated XAD-2 tube+HPLC/UV analysis

OSHA method 34, Sampling and analysis of dimethylamine using NBD-Chloride coated XAD-7 tube and HPLC/Flu analysis:

OSHA method 36, Sampling and analysis of ethylamine using NBD-Chloride coated XAD-7 tube and HPLC/Flu analysis:

OSHA method 40, Sampling and analysis of methylamine using NBD-Chloride coated XAD-7 tube and HPLC/Flu analysis:

OSHA method 41, Sampling and analysis of diethylamine using NBD-Chloride coated XAD-7 tube and HPLC/Flu analysis:

OSHA method 60, Sampling and analysis of ethylenediamine using NITC coated XAD-2 tube+HPLC/UV analysis

OSHA method 2084, *Sampling and Analytical Methods of Acetamide using silica gel tube sampling, liquid desorption and GC-NPD analysis*

US EPA Method 521 Determination of nitrosamines in drinking water by solid phase extraction and capillary column gas chromatography with large volume injection and chemical ionization tandem mass spectrometry (MS/MS), version 1.0 September, 2004

US EPA Method 0011: Sampling for selected aldehyde and ketone emissions from stationary sources

US EPA Method 6: determination of sulfur dioxide emissions from stationary sources

7.2. Literature

CSIRO 2010- H&E TQP ID1 -EP 105542 CO₂ Capture Mongstad - Project A - Task 4 • Literature Survey and Recommendations, http://www.gassnova.no/no/Documents/Literaturesurveyanalyticalprocedures_CSIRO.pdf

CSIRO 2011 - H&E TQP ID1- CO₂ Capture Mongstad - Project A – Establishing sampling and analytical procedures for potentially harmful components from post-combustion amine based CO₂ capture Task 5: Establish Analytical Procedures, http://www.gassnova.no/no/Documents/Establishanalyticalprocedures_CSIRO.pdf

Frischmann M, IEAGHG Seminar, Control of Nitrosamine Formation in CO₂ capture plants, Plausibility of total and individual nitrosamine measurements and improvements, 1st and 2nd February 2011, Essen, Germany

Mertens, J., Knudsen, J., Thielens, M.L., Andersen, J., 2012. On-line monitoring and controlling emissions in amine post combustion carbon capture: a field test. *International Journal of Greenhouse Gas Control* 6, 2–11

Mertens J., Faniel N., Characterising aerosols in flue gas using impinger methods, FTIR and ELPI+, International conference on emissions monitoring, CEM 2014, 14th-16th May, Istanbul, Turkey

Ramboll H&E TQP ID1: Establish sampling and analytical procedures for potentially harmful components post combustion amine based CO₂ capture, Ramboll-subtask 2 – Procedures for manual sampling

Ramboll H&E TQP ID1: Establish sampling and analytical procedures for potentially harmful components post combustion amine based CO₂ capture, Ramboll- subtask 3 (online analysis and sampling) http://www.gassnova.no/no/Documents/Onlinesamplingandanalysis_Ramboll.pdf

Ramboll 2010 H&E TQP ID1: Establish sampling and analytical procedures for potentially harmful components post combustion amine based CO₂ capture, subtask 4 (literature survey of analytical procedure and recommendations) http://www.gassnova.no/no/Documents/Literaturesurveyanalyticalprocedures_Ramboll.pdf

Ramboll, 2011 H&E TQP ID1: Establish sampling and analytical procedures for potentially harmful components post combustion amine based CO₂ capture, SubTask 5: Establish analytical procedures, draft report, http://www.gassnova.no/no/Documents/Establishanalyticalprocedures_Ramboll.pdf

SINTEF 2010 a H&E TQP ID1: Establish sampling and analytical procedures for potentially harmful components post combustion amine based CO₂ capture, - Subtask 2 procedure for manual sampling FM07-AJZ00-S-RA-0001-03, http://www.gassnova.no/no/Documents/Proceduresformanualsampling_SINTEF.pdf

SINTEF 2010 b H&E TQP ID1: Establish sampling and analytical procedures for potentially harmful components post combustion amine based CO₂ capture, - Subtask 4 (literature survey of analytical procedure and recommendations),

SINTEF 2010 c H&E TQP ID1: Establish sampling and analytical procedures for potentially harmful components post combustion amine based CO₂ capture, subtask 3 (literature survey of online sampling and analysis), http://www.gassnova.no/no/Documents/Onlinesamplingandanalysis_SINTEF.pdf

SINTEF 2011 H&E TQP ID1: Establish sampling and analytical procedures for potentially harmful components post combustion amine based CO₂ capture, Subtask 5: Establish analytical procedures, AJZOO-S-RA-0003-03, SINTEF 2011, http://www.gassnova.no/no/Documents/Establishanalyticalprocedures_Sintef.pdf

Wang J, Chan WG, Haut SA, Krauss MR, Izac RR, Hempfling WP, Determination of total N-nitroso compounds by chemical denitrosation using CuCl, *J. Agric. Food Chem.* 2005, 53, 4686-4691