



Capability of smart appliances to provide reserve services



Silviu Nistor^a, Jianzhong Wu^{a,*}, Mahesh Sooriyabandara^b, Janaka Ekanayake^{a,c}

^a Institute of Energy, School of Engineering, Cardiff University, Cardiff, UK

^b Toshiba Research Europe Ltd, Telecommunications Research Laboratory, Bristol, UK

^c Faculty of Engineering, University of Peradeniya, Sri Lanka

HIGHLIGHTS

- A smart appliance model considering cycle delay and interruption was developed.
- 20% of smart appliances can provide up to 1.5 GW of reserve in GB power system.
- Peak load created by load recovery is mitigated by randomizing reconnection time.
- Increasing instruction notification time enhances the level of demand response.

ARTICLE INFO

Article history:

Received 31 October 2013

Received in revised form 25 August 2014

Accepted 7 September 2014

Available online 30 September 2014

Keywords:

Power system
Operating reserves
Smart appliances
Demand response
Ancillary services

ABSTRACT

The growing share of electricity generation from renewable energy creates difficulties in maintaining the balance of generation and demand. This is mainly due to uncertainties caused by prediction errors in renewable generation. In order to maintain power system security, the participation of demand side response to the balancing services such as operating reserve is critical. In this paper, the capability of smart appliances to act as operating reserves for the system operator is investigated. The smart appliances considered are washing machines, dish washers and tumble dryers equipped with communication modules. A novel framework is introduced which enables system operators to access demand response from smart appliances in a timeframe suitable for operating reserves. A mathematical model is developed to simulate appliances with multiple discrete power phases. The delay and interruption of appliances cycles are considered in the model. A multiple time-step simulation is introduced that assesses the load reduction from a number of households as a response to a reserve instruction which is modelled as a price increase with a short notification period. The results are used to estimate the available demand response from Great Britain (GB) households at any moment of the day. With a 20% penetration of smart appliances, the demand response can provide up to 54% of the operating reserve requirements of the GB power system depending on the time of day.

© 2014 The Authors. Published by Elsevier Ltd. This is an open access article under the CC BY license (<http://creativecommons.org/licenses/by/3.0/>).

1. Introduction

The Intergovernmental Panel on Climate Change showed that because of human activity the atmospheric concentration of CO₂ has increased by 40%, methane by 150% and nitrous dioxide by 20% since pre-industrial times [1]. According to [2] the electricity and heating sector is the largest contributor, with 41%, of CO₂ emissions from fossils combustion. The United Kingdom (UK) is committed to reduce its greenhouse gases emissions 80% by

2050 from a 1990 baseline. In order to achieve this target the UK Government supports renewable energy additions through policy mechanisms such as Renewable Energy Obligation certificates and feed-in tariffs. According to [3] 5118 MW of new wind capacity and 2319 MW of solar have been installed between 2010 and the second quarter of 2013, reaching a total of 13GW capacity from intermittent generation. Great Britain's transmission system operator, National Grid Electricity Transmission plc. (NGET), has concluded that, as more wind power will be introduced, the level of reserve needed to operate the power system in 2030 will increase by 55% from the 2011 level [4]. The additional reserve will cover for wind forecast errors and wind farms shutdowns due to faults and maintenances. A lower share of flexible units in the generation mix is likely to raise the cost of procuring reserve. There is now a greater emphasis of obtaining reserves services from demand side

* Corresponding author at: Room E/2.19, Cardiff School of Engineering, Newport Road, Cardiff CF24 3AA, UK. Tel.: +44 (0)29 2087 0668.

E-mail addresses: NistorS@cardiff.ac.uk (S. Nistor), WuJ5@cardiff.ac.uk (J. Wu), Mahesh@toshiba-trel.com (M. Sooriyabandara), Ekanayakej@cardiff.ac.uk (J. Ekanayake).

and throughout this paper we will refer to it as demand response (DR). Market efficiency and system reliability can potentially be improved by using DR in reserve services.

The main services that NGET uses to procure reserve are *Fast Reserve* and *Short Term Operating Reserve (STOR)*. The reserve contracted through the *Fast Reserve* service helps control the system frequency in case of sudden demand increase due to unexpected weather change or TV pick-ups. *Fast Reserve* will also be utilised to reinstate the frequency response reserves if a generation loss occurs. The provider's maximum commitment time is 5 min and the delivery should last for 15 min. Hydro power plants are among the main providers. DR is another technology that has been providing *Fast Reserve* using the radio teleswitch electricity meters which can disconnect consumers' storage heaters when a radio instruction is issued. However, the DR from storage heaters is only available during the night in the off-peak hours of the Economy 7 tariff [5]. Economy 7 is a Time of Use (TOU) tariff offering 7 h of low electricity rates starting from midnight, with a number of subscribers estimated at approximately 9% of UK households [6]. The annual payment for *Fast Reserve* in 2011/2012 was £92 millions.

Reserve provided through *STOR* covers for the imbalances caused by the errors in supplier's demand forecast and in wind forecast. Although the system operator (SO) specifies a maximum commitment time for *STOR* of 4 h, 98% of the selected *STOR* providers can respond within 20 min [7], as one of the roles of *STOR* is to take over from *Fast Reserve* and to reinstate the committed sources. The *STOR* provider should be able to maintain the response, either increase in generation or demand reduction, for a minimum of 2 h. At the moment, the main providers of *STOR* are Open Cycle Gas Turbine (OCGT) power generators and standby diesel generators covering 54% and 18% of the *STOR* market [8]. DR participation in *STOR* is approximately 200 MW [9] from the maximum required of 2800 MW. Apart from the utilisation payment (£/MWh), NGET pays the providers for their reserved capacity (£/MW) during the periods – referred to as availability windows [10] – where events are most likely to occur. The annual *STOR* payment in 2011/2012 was £104 millions. All the above DR services are currently provided by large commercial and industrial customers.

Advances in ICT (Information and Communication Technologies) infrastructure and the reduction in its cost have motivated the appliance manufacturers to provide integrated communication modules for home automation in appliances, such as fridges, ovens and washing machines. These appliances, when aggregated, could also provide DR services. At the moment, the communication module is used to remotely turn on/off an appliance or an appliance to send an alarm to the user when the cycle is over or when maintenance is needed. However, there is an opportunity to make appliances automatically interact with the power systems towards providing reserve services such as *Fast Reserve* and *STOR*, through load shifting, within minutes of receiving instructions.

Smart appliances that delay their starting time according to a utility signal are being tested in a number of pilot projects [11,12], including some in the UK [13], and are commercially available in Europe [14]. More advanced features, such as cycle interruption, are mainly described in the research literature and not commercially available. In reference [15], a mathematical model of smart appliances with load shifting is introduced. Cycle interruption and discrete power consumption are also discussed as a possible expansion of the model. However, they were not investigated in [15]. In our paper, a smart appliance model was developed considering cycle interruption and discrete power consumption. The model was utilised to evaluate the level of demand response suitable for power system balancing services.

A review [16] on the current DR practices showed an increasing utilisation of DR as a cost-effective way to provide balancing services. The value of smart appliances in balancing the demand

and supply with high wind penetration was investigated in [17]. The shifting of appliances using a linear programming algorithm that implements a centralised direct load control (DLC) scheme was illustrated to decrease the number of part-loaded power plants that maintain the reserve margins and reduce wind curtailment. However, there are evident scalability issues with coordinating the appliances with a central controller at national level. An assessment of the flexibility of aggregated residential loads using Monte Carlo simulation was described in [18]. The study concluded that the average flexibility of a washing machine or a dishwasher, resulted from interrupting them by 15 min, is 30 W per device. In the study reported in [19], based on the smart-grid ready General Electric appliances that are capable of providing spinning reserve (similar to *NGET Fast Reserve*, but used by Independent System Operators in the United States), it was shown that through participation in this service the user of appliances could obtain an estimated 2% reduction in the annual electricity bill. A case study [20] on the Belgium power system operation with smart appliances found that the appliances have the potential to reduce the peak demand with 150 MW.

This paper investigates the potential of load flexibility enabled by domestic smart appliances to be used in reserve services, in particular for *NGET's STOR* service. An overview of the system, including the actors and the communication infrastructure that enables appliances to respond to reserve instructions from system operators, was described. A decentralised control scheme was assumed, with a shifting algorithm at the appliance level that permits the appliance to act on user settings and on a dynamic pricing signal that incorporates reserve instructions. The contribution from the appliances towards the reserve requirements of the Great Britain (GB) power system was found through simulation. The impact on appliance response from different parameters of the reserve instruction was also discussed.

2. Framework for smart appliances utilisation

With the prospect of an uptake of smart appliances, it is envisioned that the system operator can make use of their flexibility and the capability to respond to external signals to integrate them in the operating reserve. One of the important decisions for this study was the selection of appliances out of a wide variety of appliances available in modern homes today. The appliances considered in this study – washing machine, dishwasher and tumble dryer (WM, DW, TD) – have a high level of ownership (95%, 28% and 53% respectively) in the UK [21]. The selected appliances allow load management with minimum impact on user comfort. This is confirmed by the high user acceptance of smart operation for these appliances (95% for WMs, 91% for DWs and 92% for TDs [22]). Residential loads, which are used traditionally in demand response programs in many other countries, have a low ownership in the UK. For example, the ownership of air-conditioning units is estimated at 2.4% [23] and they only operate for a short summer period. For electric space heaters the ownership is below 10% [24], while most of their demand is at night where the need for reserve is low. Therefore only WM, DW and TD were considered in this study.

2.1. System overview

The envisioned system to enable reserve from appliances is depicted in Fig. 1. The participating residential customers of the DR aggregator have adopted the smart grid ready technology for their appliances (WM, DW, TD). A DR aggregator takes the responsibilities of predicting the available response from the appliances, verifying the response and rewarding the customers. The DR aggreg-

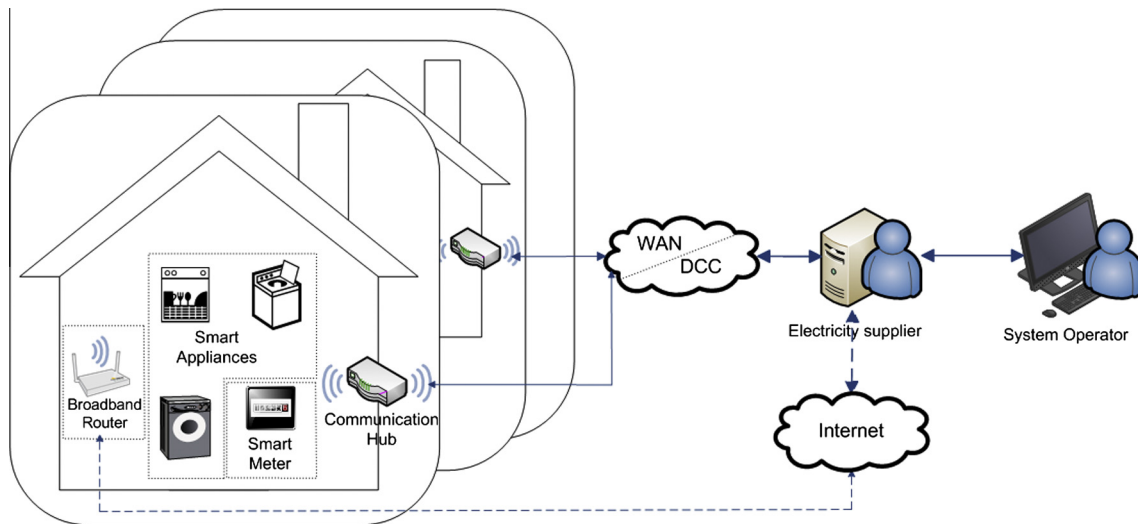

Fig. 1. Framework for the participation of residential DR in the power system balancing services.

gator will enter the *STOR* market, operated by the system operator, to capitalize the response from the appliances.

Depending on the available communication infrastructure and the contractual agreements between the DR aggregator and the customers there could be multiple solutions to facilitate the residential DR to participate to reserve services. One solution available for new entrants offering aggregation services is to use the broadband internet and the router (or a Home Energy Management System) to send the instruction to appliances. In this work, it was assumed that the electricity suppliers take the role of the DR aggregator.

The communication between the SO's central server and the electricity supplier is accomplished by an Asymmetric Digital Subscriber Line (ADSL). Through this infrastructure the supplier is declaring the available response ahead of real time. If the SO decides that reserve is needed from a supplier, it will issue a reserve instruction, e.g. 15 min ahead of real time, when the demand reduction is needed. At receipt of the reserve instruction, the supplier will increase the electricity price starting from the next 15 min interval for the duration specified by the SO. The price increase will be delivered through the smart metering communication infrastructure, owned by the Data and Communication Company (DCC) in the UK, which consists of a Wide Area Network (WAN) and a Communication Hub [25]. The smart appliances connected to the hub will receive the increased price and will delay their cycle; thus, a decrease in aggregated consumption will be achieved. This solution, where the DR signal is integrated in the price signal, is similar to Critical Peak Pricing (CPP) [26]. CPP is a DR program that relies on the customers to respond manually, therefore the notification time is on a day-ahead basis and the critical rate is up to eight times higher. In this case shown in Fig. 1, because the response is automatic, the notification time can be shorter, 15 min, and the price increase can be small, so that the cost of operating the appliances that are not shiftable to remain roughly the same.

2.2. Load management features

The appliances' cycles are modelled in detail to capture the energy as well as the power consumption. The cycle is represented by a number of processes where the consumption is approximately constant, called power phases. In Fig. 2, an approximate cycle of a tumble dryer is illustrated with six power phases. The duration of

each power phase is assumed to be 15 min, and this is used as the time step of the simulation. The average power profiles for WM, DW and TD were specified in [27] and are shown in Table 4 of the Appendix. One advantage for having power phases is the high level of control that can be imposed on the appliance operation with the help of load management features.

The load management features of the appliance are *smart start* and *cycle interruption*. The *smart start* feature allows the appliance cycle to be shifted in response to an external signal. An example of this function is also shown in Fig. 2, where the tumble dryer's operation is delayed by $T_{StartDelay}$ from evening to night, avoiding peak electricity rates. The user still has to retain the control of the appliance; thus, the *smart start* feature is dependent on the user defined parameter called *maximum delay*. The *cycle interruption* feature can pause the appliance operation between power phases as shown in Fig. 2, where the tumble dryer's operating cycle is interrupted for $T_{Interruption}$.

2.3. User dependent parameters

One of the user dependent parameters is the *activation time*, which is defined as the time the user presses the appliance ON button after he finished loading the appliances with clothes for WM and TD or dishes for DW. A domestic energy demand model (CREST [28]) was employed to generate the *activation times* for appliances. The model is based on data, such as people activity profile and ownership of appliances, derived from the UK Time Use survey [29] based on samples which, according to [30], match the distribution income of the UK population. The model outputs 24 h load profiles for each house, at a resolution of one minute, depending on the number of household occupants, season and day of the week. The profile of a house distinctly shows the load profiles of all the appliances that constitute it. In this study, it was assumed that the *activation times* of appliances are the start times of the appliances from the CREST model. This assumption is made at the expense of completing the cycle within the *maximum delay* defined by the user not within the appliances' cycle.

In this work, the number of occupants, which is required as an input to the CREST model, was chosen according to the distribution of the 25.6 million households of the GB housing stock by the number of people living in them [31] as seen in Table 1. A random generator was used to assign the number of occupants in each household according to the percentages given in Table 1. Another

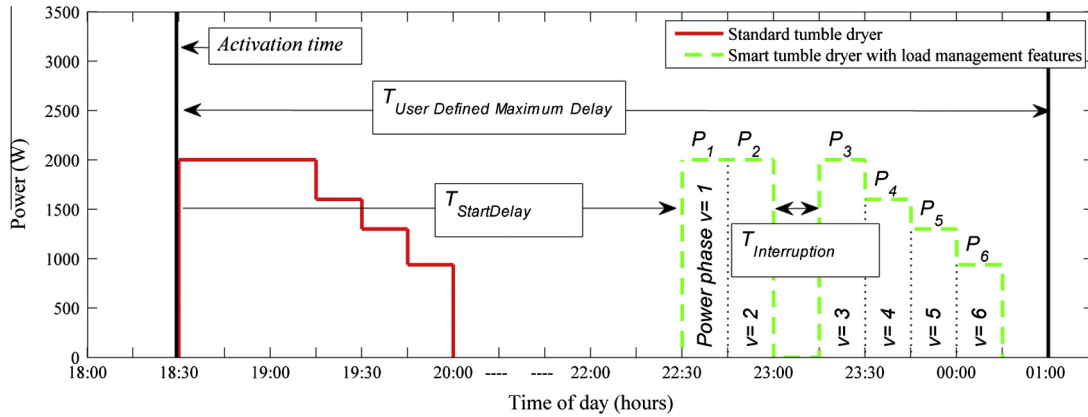

Fig. 2. Tumble dryer load profile.

Table 1
Household distribution by number of people living in them in GB [31].

No. of residents	1	2	3	4	5
Percentage from total no. of households	29	35	16.5	13	6.5

input of the model is the annual electricity consumption of the simulated households. For this study a value of 3300 kWh representing the UK average [32] was selected.

The values from a survey completed in the Smart-A project [33] were considered when deciding the user defined *maximum delay* parameter. One of the questions that the survey addressed to the users of appliances equipped with ‘start delay’ button was: “How long does your machine remains in start delay position before programme starts?” The percentages of the respondents under each number of hours of delay are given in Table 2. In this study, a random generator was used to assign from 1 h to 7 h of delays for each appliance according to the percentages given in Table 2.

2.4. The simulation model

The simulation modelled the aggregated consumption of smart appliances from N households and their response to a reserve instruction. The response is the load reduction for the duration of the reserve instruction resulted from the difference between the usual consumption and the consumption in the case with instruction. As described in Section 2.1, the reserve instruction is converted in an increase in electricity price after the notification time and lasts for the duration of the instruction. The appliances, assumed to be equipped with the load management features described in Section 2.2, will try to minimise the cost of supplying their power phases. The simulation duration was 24 h with a time step of a quarter of an hour.

The simulation, illustrated in Fig. 3, starts by generating the number of residents living in a single household, according to the percentages given in Table 1. This number inputs to the CREST energy demand model that will generate the *activation times* of appliances over 24 h. These steps will be repeated for each of the N households. Conveyed to the next step of a simulation is the matrix A , which gives the number of WM, DW, TD that are in activation mode in each time step up to 24 h.

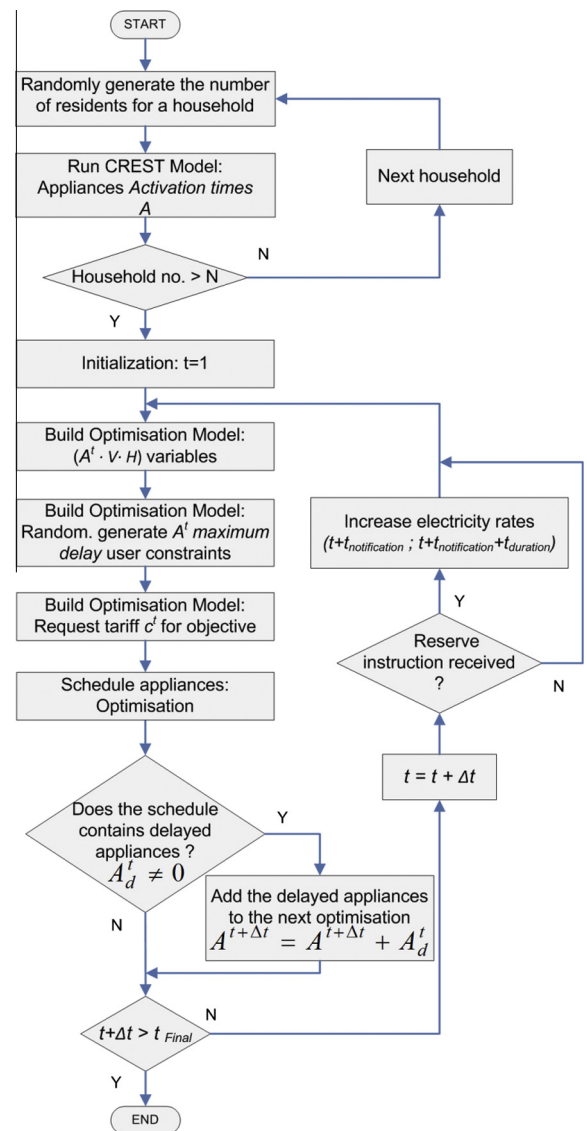

Fig. 3. Flowchart of the simulation model.

Table 2
Discrete probability for user defined *maximum delay*.

Maximum delay (hours)	1	2	3	4	5	6	7
Percentage of respondents (%)	19	19	19	9	9	9	16

At time step t_0 of the simulation there are A^0 appliances to be scheduled. Deciding the starting time of the appliances is formulated as an optimisation problem. The decision variables, x_v^t , are binary and represent the operation status of power phase v at time

t. For example, the smart tumble dryer's load profile in Fig. 2 is described with the help of the binary variables in (1).

$$\begin{pmatrix} x_1^1 & x_2^1 & \dots & x_v^1 & \dots & x_6^1 \\ x_1^2 & x_2^2 & \dots & x_v^2 & \dots & x_6^2 \\ \dots & \dots & \dots & \dots & \dots & \dots \\ x_1^t & x_2^t & \dots & x_v^t & \dots & x_6^t \\ \dots & \dots & \dots & \dots & \dots & \dots \\ x_1^7 & x_2^7 & \dots & x_v^7 & \dots & x_6^7 \end{pmatrix} \cdot \begin{bmatrix} P_1 \\ P_2 \\ P_3 \\ P_4 \\ P_5 \\ P_6 \end{bmatrix} = \begin{bmatrix} P_1 \\ P_2 \\ 0 \\ P_3 \\ P_4 \\ P_5 \\ P_6 \end{bmatrix} \quad (1)$$

The objective function of the optimisation is to minimise the cost of operating the power phases, and its mathematical formulation is given in Eq. (2). The optimisation horizon, of 8 h, was selected to accommodate the maximum delay that the user can allow for an appliance, i.e. 7 h which was selected according to the survey results shown in Table 2.

$$\min_{x_{v,a}^t} \left\{ \sum_{a=1}^{A^{t_0}} \sum_{v=1}^{V_a} \sum_{t=t_0}^{t_0+H} C^t \cdot x_{v,a}^t \cdot P_{v,a} \cdot \Delta t \right\} \quad (2)$$

where $x_{v,a}^t$ is the binary variable representing if the power phase v of the appliance 'a' is operating at time t , A^{t_0} is the number of appliances activated at time t_0 , H is the horizon of the optimisation, V_a is the number of power phases of the appliance 'a', C^t is the electricity rate at time t , $P_{v,a}$ is the power consumption for the power phase v of the appliance 'a', Δt is the 15 min time step.

The constraint in Eq. (3) requires the appliance 'a', and therefore each of its power phases, to operate in the interval defined by the user ($t_0, t_0 + T_{MaxDel}$), where T_{MaxDel} is generated for each appliance according to Table 2. The constraint given in Eq. (4) ensures the correct order of the power phases, more explicitly that the power phase $v + 1$ will operate after v (see Fig. 2), for example that in a washing machine the rinse phase is scheduled following the washing phase. The maximum interruption time between power phases is modelled by Eq. (5) as the difference between the operation times of the successive power phases v and $v + 1$.

$$\sum_{t=t_0}^{t_0+T_{MaxDel}} x_{v,a}^t = 1 \quad x \in \{0, 1\}, \quad \forall a \in (1, \dots, A^{t_0}), \quad \forall v_a \in (1, \dots, V_a) \quad (3)$$

$$\left(\sum_{t=t_0}^{t_0+T_{MaxDel}} x_{v+1,a}^t \cdot t - \sum_{t=t_0}^{t_0+T_{MaxDel}} x_{v,a}^t \cdot t \right) \geq 1, \quad x \in \{0, 1\}, \quad \forall a \in (1, \dots, A^{t_0}), \quad \forall v_a \in (1, \dots, V_a - 1) \quad (4)$$

$$\left(\sum_{t=t_0}^{t_0+T_{MaxDel}} x_{v+1,a}^t \cdot t - \sum_{t=t_0}^{t_0+T_{MaxDel}} x_{v,a}^t \cdot t \right) \leq T_{offv} \quad x \in \{0, 1\}, \quad \forall a \in (1, \dots, A^{t_0}), \quad \forall v_a \in (1, \dots, V_a - 1) \quad (5)$$

Following the optimisation, the appliances that are not scheduled to start immediately, A_a^t , will be added for the optimisation at the next time interval. At the next time interval, the simulation checks if there is a reserve instruction, in which case it will increase the electricity rate after the notification period for the duration of the reserve. These simulation steps are repeated until the end of the day. By comparing the resulting consumption with the usual consumption, without the reserve instruction, the load reduction is found.

In order to assess the potential reserve level that could be obtained by appliances in the GB power system, the user behaviour in each of the 25.6 million households needs to be ascertained. However, considering the limited diversity in the utilisation of appliance, a smaller number of customers can be assumed to rep-

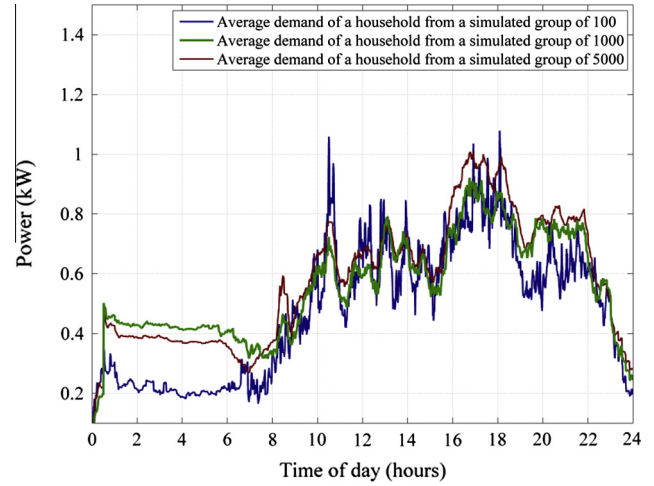

Fig. 4. Average household demand simulated with a high resolution energy demand.

resent this large population. As illustrated in Fig. 4, the average load profile shows small changes after aggregating a certain number of households. For example the changes seen between the aggregated load profile of 1000 households and 5000 households are not significant. For this reason, and also for computational efficiency, 1000 households were used to model the response from the GB residences.

3. Performance and results

3.1. Performance test of the algorithm

Fig. 5 illustrates the response of smart appliances (WM, DW, TD) from 1000 households to a reserve instruction. In this example the households are subscribed to single rate electricity tariffs. The reserve instruction has the parameters of a STOR instruction: 15 min notification time and duration of 2 h. The appliances receive the increased electricity rates at 9:45 am. The load reduction that was considered as reserve was measured between 10:00 am and 12:00 am. The load reduction obtained from the 1000 households during the 2 h is variable and has a mean of 156 kW.

The load reduction is followed by a load recovery period. The load recovery has higher values than the reduction due to the loss in diversity of usage of appliances. The appliances allowed to be delayed or interrupted by the user will start or continue their operations immediately after the instruction ends. The post instruction peak is increased by 270% compared to the original peak. The load diversity was reinstated by delaying the appliances that want to start after the reserve instruction with a random offset. The random offset takes values between 1 and 60 min and is applied to appliances for 2 h after the instruction. For this scenario, the new peak, represented in blue¹ in Fig. 5, is only 170% of the original peak.

Fig. 6 shows the response to a reserve instruction from 1000 households subscribed to the TOU electricity tariff. The tariff with ten off-peak hours, five of them in the afternoon and evening, shapes the aggregated load profile of the appliances. To exemplify the impact of the tariff on the appliances' response, a STOR instruction is issued at 12:00. In the first hour of the instruction the load reduction obtained has an average of 42 kW due to the low availability of appliances during the peak price period. For the second

¹ For interpretation of colour in Fig. 5, the reader is referred to the web version of this article.

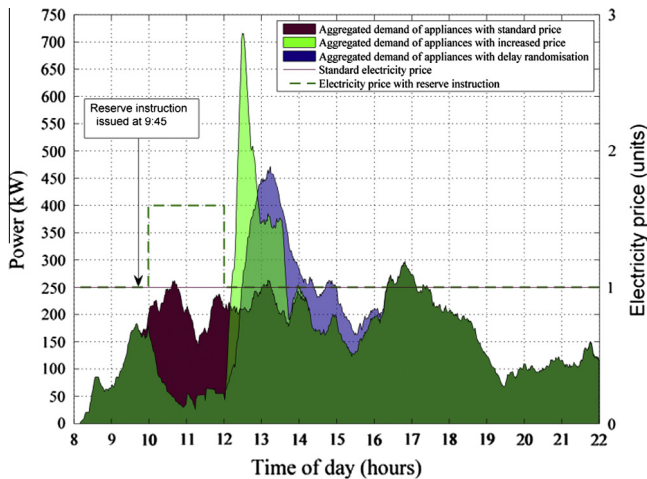

Fig. 5. Aggregated demand of appliances (WM, DW, TD) from 1000 households with single rate tariff and their response to a reserve instruction.

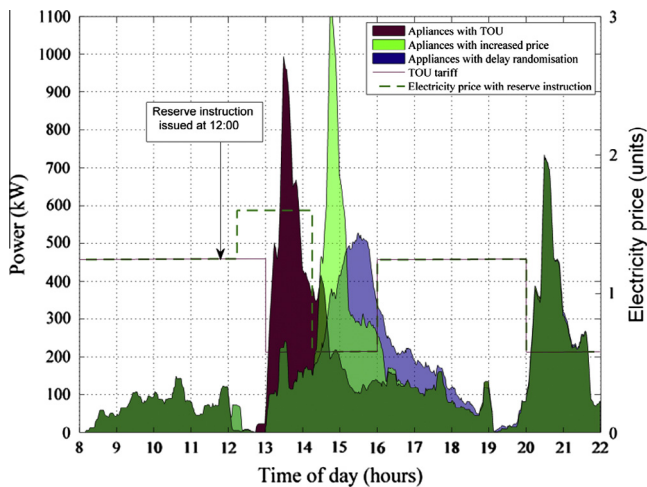

Fig. 6. Aggregated demand of appliances (WM, DW, TD) from 1000 households with TOU tariff and their response to a reserve instruction.

hour, the load reduction has an average of 458 kW because the appliances that have been waiting to start at the lower price period will be further delayed at the end of the instruction. For TOU, the random offset between 1 and 60 min will reduce the original peak by 47%.

3.2. Availability of reserves from smart appliances for the GB power system

The response obtained using the previous simulations was scaled in order to estimate the reserve that smart appliances can provide at the national level. The scaling was performed without a loss of rigor, as the samples were calibrated to be representative of the UK population as a whole, as detailed in Section 2.3. The assumption for this scenario is that 20% of GB households have adopted smart appliances (WM, DW and TD). The response was compared against the maximum required *STOR* level at the moment of 2800 MW. As shown in Section 3.1, the response depends on the time of the day when the reserve instruction is issued. Hence, to get the available response during a day, simulations were repeated with uncorrelated reserve events over a 24 h period. The influence on the load reduction of the reserve instructions parameters – notification and duration – was investigated.

The available reserve in the case where the instructions' duration is 2 h is illustrated in Fig. 7. To highlight the relation between the available reserve and the time at which the instructions are issued, two lines have been plotted, representing the load reductions if instructions are issued at even or odd hours throughout the day. It is worth noting that even though Fig. 7 shows a continuous variation of the available reserve, in fact it constitutes of a number of 2 h plots shown in a single 24 h time axis. A notification time of 15 min for the instructions is considered in the left figure and 60 min in the right figure. The load reduction can cover up to 49% of the maximum *STOR* that *NGET* requires to safely operate the GB power system. When the appliances are notified 1 h prior to the delivery time a higher result is achieved: 54% or 1.5 GW. Additionally, the increased notification time means that demand reduction is prompter in its response, similar to a generator with a quicker ramp-up capability, at the times the delivery of the response is required.

The available reserve in the case where the instructions' duration is 1 h is illustrated in Fig. 8. In the left figure, the instructions are issued with 15 min notification at 00' of each hour, with black, and at each 30' of each hour with grey. In the figure on the right side the reserve instructions have a notification of 1 h. By comparing with the previous case it can be seen that the notification of the reserve instruction has a bigger impact on the magnitude of the load reduction than the duration of the modification.

The availability windows are the periods during the time span of a day where providers are rewarded for committing their resources for *STOR*. Outside the availability windows the providers are paid only if their resource is utilised. The number of windows in a day and their durations varies with the system demand. They reflect the intervals with the highest requirements for operating reserves. Although the available reserve from appliances varies throughout the day, the average values during the availability windows could provide a rule of thumb for policy makers. The results for the estimated load reductions with different reserve instruction parameters are summarised in Table 3.

In the context discussed in Section 2.1, the shifting of the appliances will leave the electricity supplier, acting as the DR aggregator, with volumes of energy different from those contracted. For the period of the reserve instruction, the supplier has its contracted volume suitably adjusted with the response provided to the system operator, thus avoiding imbalance charges. However, the supplier will have to cater for the load recovery period. The suppliers can modify their contracted position by trading in power market exchanges between the time that reserve notification is received and gate closure. At a system level, the described solution allows reserve to be supplied through more efficient power plants. In the case of GB, the smart appliances could help replacing less efficient OCGTs and diesel generators by more efficient combined cycle gas turbine (CCGT) power plants even though they have a slower response.

Another observation is that the load reduction is not constant throughout the reserve call. This is caused by user behaviour and variable load profile of appliances. At the moment, the system operators' requirements for accurate and constant response during the reserve instruction are more appropriate for generators and therefore new services will have to be introduced for DR integration.

Based on the results obtained in this paper, future research could be carried out to improve the control over the level of demand response obtained from smart appliances by segmenting the pool of consumers into smaller groups, each with different reserve instructions. In addition, demand response could be used by transmission system operators for frequency response and reserve services, and by distribution network operators for network support. Therefore, future research is needed to investigate

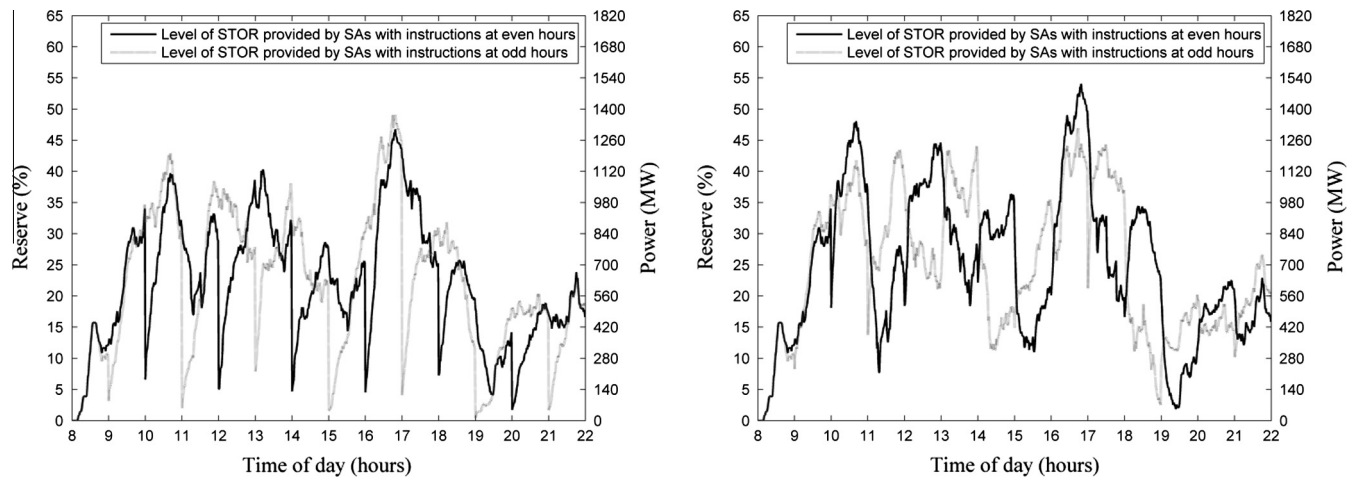

Fig. 7. Available reserve from 20% of appliances (WM, DW, TD) in GB for reserve instructions with duration of 2h and: (left) 15 min notification time and (right) 1 h notification time.

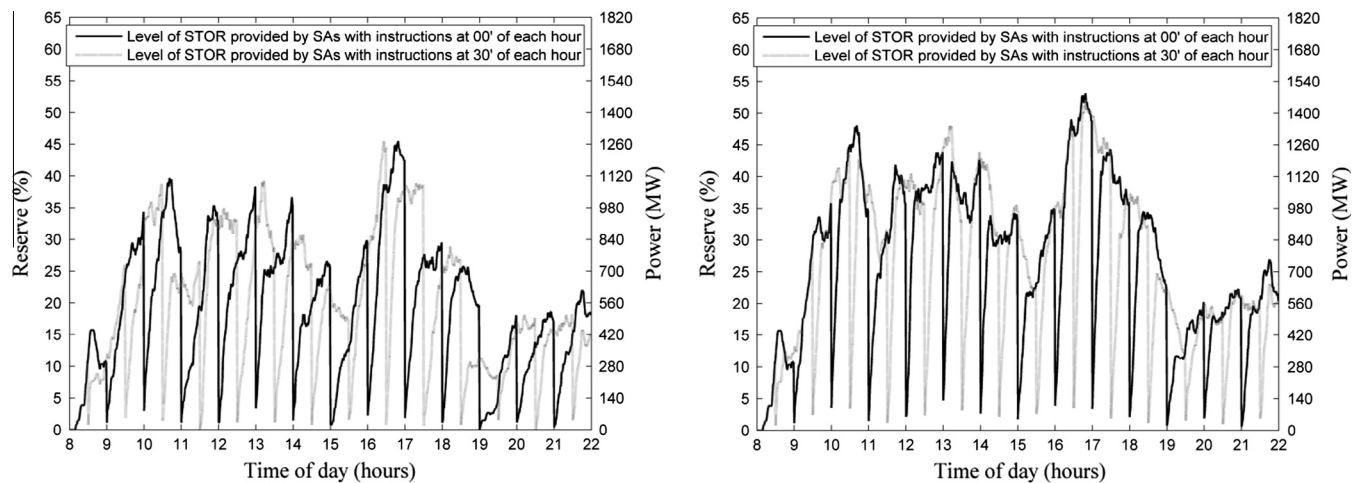

Fig. 8. Available reserve from 20% of appliances (WM, DW, TD) in GB for reserve instructions with duration of 1 h and: (left) 15 min notification time and (right) 1 h notification time. (Note: SAs abbreviates smart appliances).

Table 3

Estimates of the availability of DR from 20% of appliances (WM, DW, TD) in GB.

Instruction parameters	Reserve level available from smart appliances (MW)						
	Availability windows						
Duration / Notification	00:00–07:30	07:30–14:00	14:00–16:00	16:00–18:00	18:00–19:30	19:30–22:30	22:30–00:00
1 h/15 min	20	634	636	935	499	396	109
1 h/60 min	26	807	874	1213	756	518	163
2 h/15 min	23	693	677	1040	575	434	101
2 h/60 min	26	788	810	1179	678	497	160

the coordination of smart appliances to provide various services effectively.

4. Conclusions

The capability of smart appliances to participate in power system balancing services was investigated. A framework to enable demand response from smart appliances, with the electricity supplier acting as a demand response aggregator, was discussed. The simulation used an energy demand model to obtain activation times of appliances from N households. The task of deciding, at

each time step, the starting times of appliances with respect to electricity price and user preferences was formulated as an optimisation problem. The reserve instruction was modelled as price increase with a short notification period. One thousand households in GB participating in the *STOR* service were simulated.

The results showed that the response of the considered appliances (washing machine, dishwasher and tumble dryer) is well suited to be integrated in the balancing services. The shifting and interruption of appliance operation, according to user preferences, resulted in a fast decrease in consumption at the system level. The electricity tariff, to which the customer has subscribed, shaped the

Table 4
Appliances consumption profiles [27].

Power phase (15 min)	Washing machine	Dish washer	Tumble dryer
P_1	100 W	80 W	2000 W
P_2	2000 W	2000 W	2000 W
P_3	900 W	80 W	2000 W
P_4	100 W	80 W	1600 W
P_5	100 W	80 W	1300 W
P_6	300 W	2000 W	940 W
P_7	50 W	300 W	–
P_8	–	150 W	–

availability of the appliances and the reserve they can provide over 24 h. Increasing the time between the moment when the reserve instruction was issued and the delivery time of the reserve ensured a higher value of response from appliances. With only 20% penetration of smart appliances in the GB residential sector, a significant share of up to 54% of the maximum STOR level required in the GB power system operation can be achieved. The smart appliance model with cycle delay and interruption is generic and is applicable to various countries. The same statement is valid for the framework used to obtain the level of operating reserves from the studied appliances. However, the results of the simulation are likely to differ from one country to another because of the country specific data related to appliance utilisation. Consideration should be given on heating and air conditioning units for demand response, if a country has more intense climate than that of the UK.

Acknowledgements

This work described in this report was sponsored by Toshiba Research Europe Ltd and by Cardiff University President's Scholarship Scheme. The authors acknowledge the UK-China EPSRC Grant EP/K006274/1 for partial financial support of this work.

Appendix A

(See Table 4).

References

- [1] Alexander L, Allen S, Bindoff N, Bréon F-M, Church J, Cubasch U, et al. IPCC 2013: summary for policymakers. In: Climate change 2013: the physical science basis. Contribution of working group I to the fifth assessment report of the intergovernmental panel on climate change, 2013. p. 7.
- [2] International Energy Agency. CO₂ emissions from fuel combustion. <<http://www.iea.org/co2highlights/co2highlights.pdf>>; 2012.
- [3] Hemingway J, Prime J. Section 6 – renewables. DECC – energy trends. <https://www.gov.uk/government/uploads/system/uploads/attachment_data/file/244726/renewables.pdf>; 2013 [accessed 13.08.13].
- [4] National Grid. Operating the electricity transmission operating networks the in 2020. <<http://www.nationalgrid.com/uk/Electricity/Operating+in+2020/>>; 2011.
- [5] Energy Networks Association. Radio teleswitch services. <<http://79.171.36.154/rts/moreinfo.asp>>; 2013 [accessed 01.02.13].
- [6] Ipsos Mori. Consumer experiences of time of use tariffs. <<http://www.consumerfocus.org.uk/files/2012/09/Ipsos-MORI-report-on-Consumer-Experiences-Of-Time-Of-Use-Tariffs.pdf>>; 2012.
- [7] National Grid. Short term operating reserve: annual market report 2010/2011. <http://www.nationalgrid.com/NR/rdonlyres/AD980857-E490-4943-81D5-D08A84B6776B/50871/STOR_End_of_Year_Report_2010_11.pdf>; 2011.
- [8] National Grid. Short term operating reserve: fuel type analysis – season 7.3 (19/08/13–23/09/13). <http://www.nationalgrid.com/NR/rdonlyres/445313F5-1F90-4289-AB1E-E12D5A2B4942/62970/STOR_Fuel_Type_Analysis_Summary_Season_7_3.pdf>; 2013.
- [9] Ward BJ, Pooley M, Owen G, First S. What demand-side services can provide value to the electricity sector? <http://www.sustainabilityfirst.org.uk/docs/2012/Sustainability_First_-_GB_Electricity_Demand_-_Paper_4_-_What_demand_side_services_can_provide_value_to_the_electricity_sector_-_June_2012.pdf>; 2012.
- [10] National Grid. STOR market information report: TR 13. <<http://www.nationalgrid.com/NR/rdonlyres/87A8E26D-1F52-476E-9CFA-8B21974A0D43/46451/MIRTR13.pdf>>; 2012.
- [11] ENEXIS, Jouw energie moment pilot project. <http://jouwenergiemoment.nl/pdf/factsheet_uk.pdf>; 2012.
- [12] MeRegio Smart Grid Project. <<http://www.meregio.de/en/>>. [accessed 01.02.14].
- [13] Sidebotham L. Customer-led network revolution: progress report 6, 2013. p. 1.
- [14] SG Ready' gains momentum. Miele the magazine. <http://press.miele.com/de/en/press/article/artikel_109_2011.aspx>; 2011 [accessed 01.02.14].
- [15] Mohsenian-Rad A-H, Leon-Garcia A. Optimal residential load control with price prediction in real-time electricity pricing environments. *Smart Grid IEEE Trans* 2010;1(2):120–33.
- [16] Shen B, Ghatikar G, Lei Z, Li J, Wikler G, Martin P. The role of regulatory reforms, market changes, and technology development to make demand response a viable resource in meeting energy challenges. *Appl Energy* 2014;130:814–23.
- [17] Silva V, Stanojevic V, Pudjianto D, Strbac G. Value of smart domestic appliances in stressed electricity networks. <http://www.smart-a.org/W_P_4_D_4_4_Energy_Networks_Report_final.pdf>; 2009.
- [18] Pagliuca S, Lampropoulos I, Bonicolini M, Rawn B, Gibescu M, Kling WL. Capacity assessment of residential demand response mechanisms. In: Universities' power engineering conference (UPEC), proceedings of 2011 46th international, 2011. p. 1–6.
- [19] Fuller J, Parker G. Modeling of GE appliances: cost benefit study of smart appliances in wholesale energy, frequency regulation, and spinning reserve markets, Washington; 2012.
- [20] Dupont B, Dietrich K, De Jonghe C, Ramos A, Belmans R. Impact of residential demand response on power system operation: a Belgian case study. *Appl Energy* 2014;122:1–10.
- [21] Möllering C, Löwenhag J. Local energy & smart appliances: impact of smart appliances on the use of locally generated renewable energy. <http://www.smart-a.org/WP_3_D_3_3_Local_Energy_and_Smart_Appliances.pdf>; 2009.
- [22] Mert W. Smart-A project: consumer acceptance of smart appliances, 2008. p. 20.
- [23] He J, Young AN, Pathan A, Oreszczyn T. Air conditioning energy use in houses in Southern England. In: Dynamic analysis, simulation and testing applied to the energy and environmental performance of buildings, 2005. p. 6.
- [24] Palmer J, Cooper I. United Kingdom housing energy fact file, 2013.
- [25] Department of Energy and Climate Change. Smart metering implementation programme: government response to the consultation on the second version of the smart metering equipment technical specifications, 2013.
- [26] Bego A, Li L, Sun Z. Identification of reservation capacity in critical peak pricing electricity demand response program for sustainable manufacturing systems. *Int J Energy Res* 2013. n/a–n/a.
- [27] Stamminger R, Broil G, Pakula C, Jungbecker H, Braun M, Rudenauer I, et al. Synergy potential of smart appliances – smart-a project. <http://www.smart-a.org/D2.3_Synergy_Potential_of_Smart_Appliances_4.00.pdf>; 2008.
- [28] Richardson I, Hodgson G, Thomson M, Infield D, Delahunty A. Simulation of high-resolution domestic electricity demand based on a building occupancy model and its applicability to the study of demand side management. In: The 5th international conference on energy efficiency in domestic appliances and lighting (EEDAL), June 16–18, Berlin, 2009.
- [29] Richardson M. The United Kingdom 2000 time use survey. National Statistics Publication; 2003.
- [30] Burchardt T. UK Time use survey 2000 – imputed net income and childcare expenditure variables. London School of Economics; 2000. p. 6.
- [31] Office for National Statistics. Families and households, 2001 to 2011. <http://www.ons.gov.uk/ons/dcp171778_251357.pdf>; 2012.
- [32] OFGEM. Typical domestic energy consumption figures, 2011. p. 1.
- [33] Suljug A, Hillenstedt A. Domestic washing machines and dishwashers. Task 3: economic and market analysis. Preparatory studies for eco-design requirements of EuPs, Bonn, 2007. p. 56–7.