

Contents lists available at ScienceDirect

Sensing and Bio-Sensing Research

journal homepage: www.elsevier.com/locate/sbsr

Human security from death defying gases using an intelligent sensor system



Kumar Visvam Devadoss Ambeth

Computer science and Engineering, Panimalar Engineering College, Chennai 600123, India

ARTICLE INFO

Article history:

Received 17 December 2015

Accepted 11 January 2016

Keywords:

Human

Hazardous gas

GSM

Environment

ABSTRACT

Hazardous gas contamination causes threat to human life. In many developing countries, the sewers are still cleaned by unskilled laborers. Situations may arise where harmful gases may get emitted via sewage and can potentially endanger life. Furthermore, in coal mining, there is a possibility of hitting a source of natural gas which cannot be determined unless or until a sensor is utilized. To prevent such hazardous situations, this new gas detection system detects those types of gases, analyzes them for us and provides essential details about it.

Our system is designed to track the presence of hazardous gases, identify the safety limit and calculate the level in that situation, thereby preventing hazards to human life. It allows detection of carbon monoxide and methane at the given time, along with their accurate concentration values in ppm. The system also provides a threat detection alert so that the persons immediately evacuate that area, thereby preventing any possible dangers. The alert messages are broadcasted using GSM technology and hence, can be used to notify other rescue workers about the potential hazard the worker is facing at the moment.

© 2016 Published by Elsevier B.V.

1. Introduction

The ardent passion towards contributing to the society in order to save human lives was the main reason behind the origin of this project. Various articles which stated the numerous cessations of human lives while attempting to treat underground sewers intrigued our team to develop the model. [1,2] For those who work in atmospheres that could be hazardous to their health, selecting the right gas detector could be the single most important decision they could ever make. Their life could hinge on that decision so it is critical that the user make him aware of the hazards that could be encountered and the proper sensors to protect them. Data gathered in the late seventies and early eighties indicated that 65% of all those who died in confined spaces were unaware that the space they were entering was a potential hazard. Over 50% of confined space deaths occur to the rescuers and over one third of the fatalities occurred after the space was tested and declared safe and the gas detector was removed.

Gas detectors have been around for a long time, starting with that infamous methane sniffing canary, which sadly was a one-shot device, which when subjected to methane, tended to die rather quickly with no audio and visual alarm capabilities other than being slightly cheap and a total lack of motion. Fortunately technology has advanced significantly and we find ourselves at this point in time with some very sophisticated electronic equipment. But even the most sophisticated

technology is useless if the sensors used are unable to detect the gases present.

Such references and may more throw light on the fact that the sewer gases contribute a major role in the mortality rate. The overall causal ratio may be small in comparison with others, but is still not a good reason to ignore the situation as life, however small it may be still has to be valued.

Tragedies like this frequently happen when gas monitors either are used improperly or not used at all. Manufacturers tirelessly work to make their instruments easier to use in an effort to eliminate such tragedies. But no matter how user-friendly the instruments become, if employees do not use them properly, injury and death on the job will continue to occur. Deciding to use a gas detector is a smart thing to do. These factors formed the basis behind the origin of the paper.

Sewer gas is a complex mixture of toxic and nontoxic gases produced and collected in sewage systems by the decomposition of organic household or industrial wastes, typical components of sewage. Sewer gases may include hydrogen sulfide, ammonia, methane, carbon monoxide, sulfur dioxide, and nitrogen oxides. Improper disposal of petroleum products such as gasoline and mineral spirits contributes to sewer gas hazards. Sewer gases are of concern due to their odor, health effects, and potential for creating fire or explosions.

In developing countries like India, the sewers are still being cleaned by unskilled laborers. Situations may arise where the hazardous gases emitted by the sewage endanger their lives. Furthermore, a similar situation may arise during the process of coal mining where the miners may get exposed to such harmful gases, a highly concentrated exposure of

E-mail address: ambeth_20in@yahoo.co.in.

which, may even lead to their death. Thus an efficient method to detect the presence of such harmful gases becomes a necessity.

Our prime objectives are:

- ✓ To track the presence of hazardous gases, the most threatening among them namely carbon monoxide and methane present in trenches
- ✓ To identify the safe limits of these gases and calculate the level in that situation.
- ✓ Concentration of these toxic gases present in the air is identified accurately in ppm (parts per million)
- ✓ To warn the workers about the potential threats that they might face on account of exposure to such gases above a safe limit by sending the effect of the gas at that level through GSM technology.

2. Related work

In 2013, Sunny et al. [3] came up with a new method for classification of gases/odors called average slope multiplication (ASM) using dynamic characteristics of thick film gas sensor array. In 2013, W. Khalaf [4] pointed out in Sensor array system for gases identification and quantification that a practical electronic nose for simultaneously estimating many kinds of odor classes and concentrations. The multi-input/multi-output function is decomposed into multiple many to one task. Dae-Silk Lee et al. [5] designed a sensor array with nine discrete sensors integrated on a substrate to recognize the species and quantify the amount of explosive gases. A review of the pattern analysis of machine olfaction was laid before by Ricardo Gutierrez-Osuna [6] a member of IEEE.

In 2014, Sunny et al. [7] proposed a new feature technique called average slope multiplication to quantify individual gases/odors using dynamic responses of sensor array. Ozmen and Tekce [8] presented a system which is made of an array of eight phthalocyanine-coated QCM sensors and an ANN to find the corresponding composition of a gas mixture. In 2011, Ravi Kumar et al. [9] laid before a new soft computational approach using multi scale principle component analysis/ (MSPCA) for discrimination of gases. The network was found to identify the gases with a high success rate. Ali Gulbag and FevzullahTemurtas [10] put forward an adaptive neuro-fuzzy inference system (ANFIS) for quantitative identification of individual gas concentrations in their gas mixtures. S. Capone et al. [11] proposed an array of highly sensitive and mechanically stable gas sensors based on different sol-gel fabricated Pd-doped SnO₂ nanocrystalline thick films which were used to detect concentrations of the range 0–100 ppm CO and 0–4000 ppm CH₄ at 50% relative humidity. Li Jing et al. [12] applied the principle of electronic nose system in artificial olfactory system which combines gas sensor array and artificial neural network recognition.

3. Proposed method

A gas detecting system is developed to protect the life of trench workers from toxic gases. The basic idea of this system is to calculate a safe limit point 'x', when the system detects a value 'y' (near to and less than 'x') and then alert the environment. If the value exceeds 'x', then system should provide a higher level threat detection alert so that the persons immediately evacuate that area, thereby preventing any possible dangers. The alert messages are broadcasted using GSM technology.

The system is designed in such a way to detect the presence of carbon monoxide and flammable gases. The most commonly found flammable gas in trenches is methane. The system uses two sensors namely MQ-2 and MQ-7 for the detection of these gases in air. An Arduino board containing an Atmega 328 microcontroller is used for processing. Arduino senses the environment by receiving inputs from the two sensors, and affects its surroundings by controlling the

actuators. The actuators used are an alarm and a LED light. The actuators are configured in such a way they light up or give out a warning noise only if the gases present in air exceed the threshold value. The whole system is developed using the Arduino programming language in the Arduino development environment. A GSM shield is used to alert the user about the presence of toxic gases using text messages. It can also be used to alert co-workers or rescue workers to help the users in case of an emergency. Given below is the basic system's architecture Fig. 3.1

The components present in the gas detecting system are:

- Power Device and Sensor System
- Arduino Component
- Voltage Divider Circuit
- Calibration
- LCD Arduino Circuit
- GSM System

3.1. Power device and sensor system

The power device is designed to convert high voltage AC mains electricity to a suitable low voltage supply for electronic circuits and other devices. This unit in the gas detecting system is used to convert the 230 V Alternating current from the mains and provide the electrical components with the required regulated 5 V direct Current. The sensors, Arduino board and the LCD display need a regulated power supply but the GSM modem contains an inbuilt voltage regulator and hence does not need the power device.

The transformer of 230v/15-0-15v is used to perform the step down operation where a 230 V AC appears as 15 V AC across the secondary winding. The rectifier is used to convert the Alternating Current (AC) to Direct Current (DC) with the use of four diodes. This process is known as rectification. The filtering circuit is used to smoothen out the circuits so that it doesn't damage even the most sensitive of the circuits. Capacitor is introduced into the circuit to accomplish the filtering process. The voltage regulator is used to maintain a constant voltage level which is being supplied to devices.

A sensor is a transducer whose purpose is to detect some characteristic of its environment. It detects any change in events or change in quantity and provides an output as an electrical signal. The two metal oxide semiconductors used are MQ-7 for the detection of carbon monoxide and MQ-2 for the detection of flammable gases. The sensors can work with very less amount of power supply and hence it makes them portable. The sensors contain 6 pins, 4 of them are used to fetch signals and the other two are used for providing heating current. Optimal heating current is needed for the working of the sensor. The sensors are connected to a power supply of 5 V which provides the required circuit voltage for the proper functioning of the sensors. The sensor unit detects the change in environment and reports it to the Arduino in the form of electrical signals.

The preferred wiring for the sensor is to connect both 'A' pins together and both 'B' pins together. It is safer and it is assumed that it has more reliable output results. In the picture, the heater is for +5 V and is connected to both 'A' pins. This is only possible if the heater needs a fixed +5 V voltage. The variable resistor in the picture is the load-resistor and it can be used to determine a good value. A fixed resistor for the load-resistor is used in most cases.

3.2. Arduino-sensor circuit

Arduino is used for the processing of the electrical signals received from the two sensors. The connections between the Arduino and the sensor board are shown in the figure below. The black wire indicates the ground connection and the red wire indicates 5 V circuit voltage. The analog output from the sensor is connected to the analog input

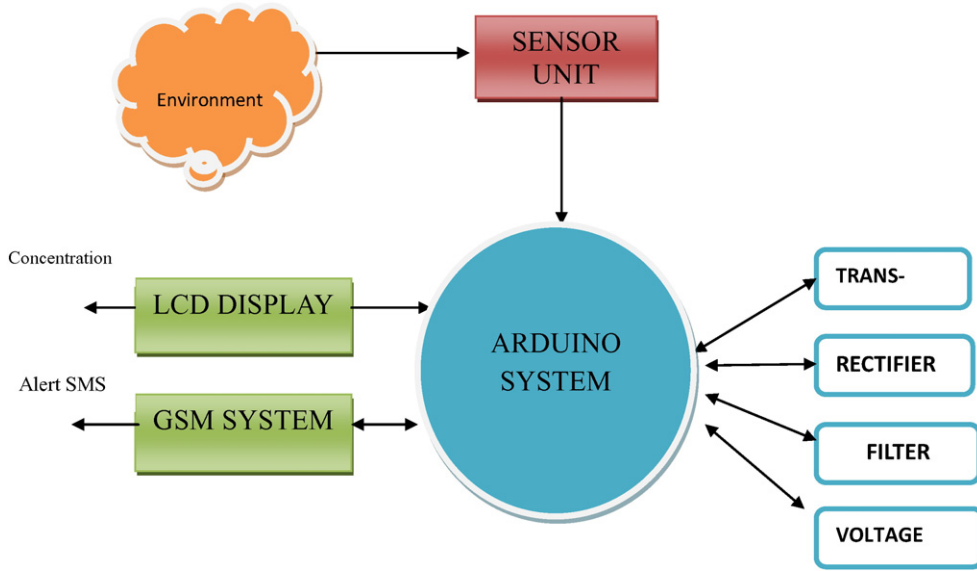

Fig. 3.1. Proposed System.

pin in the Arduino. Similarly the digital output from the sensor is connected to one of the digital input pins.

1. GND of Arduino to GND of sensor
2. 5 V of Arduino to 5 V of sensor
3. Analog O/p of sensor to any one of the analog ports of Arduino
4. Digital O/p of sensor to any one of the digital pins of Arduino.

Fig. 3.2 represents the Sensor and Arduino Connection. The Arduino is made to read the analog output from the sensor using the analog read () function. The analog read function reads the value from the specified analog pin. The Arduino board contains a 6 channel bit analog to digital converter. This means that it will map input voltages between 0 and 5 V into integer values between 0 and 1023 [11].

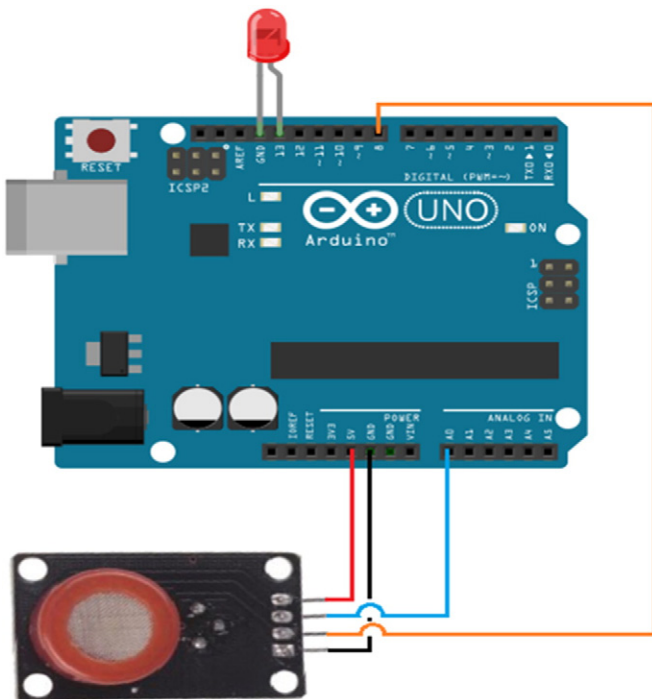

Fig. 3.2. Sensor and Arduino Connection.

The integer values read using the analog read function are converted back to their analog voltages using the arithmetic calculation:

$$V = 5.0 * \text{analog Read}(\text{pin})/1023$$

In Table 3.1, the analog voltage is calculated to find the resistance of the sensor at any moment. A voltage divider circuit explains the resistance calculation. (See Tables 3.2–3.5.) (See Tables 4.1 and 4.2.)

3.3. Voltage divider circuit

Fig. 3.3 represents the voltage divider circuit. It contains a load resistor R1 of known value and a variable resistor R2 which keeps changing. Voltage division is the result of distributing the input voltage among the components of the divider. A simple example of a voltage divider is two resistors connected in series with the input voltage applied across the resistor pair and the output voltage emerging from the connection between them. Since the two resistors are connected in series, the current passing through each resistor at every point is equal.

$$\text{Ampere}(R1) = \text{Ampere}(R2)$$

Ohm's law states that the current through a conductor between two points is directly proportional to the potential difference (voltage) across the two points. Introducing the constant of proportionality, the resistance, one arrives at the usual mathematical equation that describes this relationship:

$$V = IR$$

Table 3.1
Analog values and their respective voltages.

Analog value	Voltage conversion
100	0.48828
200	0.97656
300	1.46484
400	1.95313
500	2.92969

Table 3.2
Voltage with their respective resistance values.

Voltage V	Resistance R
1	4000
2	1500
3	666.667
4	250
4.99	2.0041

Table 3.4
Output of LINEST function.

-2.69208	8.343234
-2.69208	8.343234
-2.69208	8.343234
-2.69208	8.343234
-2.69208	8.343234

So the amount of current passing through resistor R1 can be expressed as:

$$\text{Ampere}(R1) = V1/R1$$

Similarly the current passing through the resistor R2 can be calculated in terms of voltage and resistance. The voltage in resistor R2 is V2 which should be the reduction of voltage V1 from the input voltage. In other words the voltage through the resistors R1 and R2 should sum up to the input voltage Vin. Hence the current through the variable resistor R2 can be calculated by

$$\text{Ampere}(R2) = (V2 = Vin - V1)/R2$$

Since the amount of current passing through resistor R1 is equal to the current passing through resistor R2.

$$V1/R1 = (Vin - V1)/R2$$

Multiply with R2 on both sides gives:

$$R2 * V1/R1 = (Vin - V1)$$

Divide by V1 on both sides gives:

$$R2/R1 = (Vin - V1)/V1$$

The variable resistance of the gas sensor can be calculated using the formula:

$$R2 = R1 * (Vin - V1)/V1$$

where R2 is the amount of resistance in the variable resistor. Vin is the input voltage and V1 is the voltage at load resistance R1. The load resistance is used to accept electric current from a source and causes a voltage drop when it is conducting a current. With no load (open-circuited terminals), all of Vin falls across the output. However, the circuit will behave differently if a load is added. The load resistance used in both MQ-2 and MQ-7 sensor is 1 kohm. This gives good selectivity but increasing the load resistance reduces the

accuracy of the concentration of the specific gas present in the air at very high levels.

3.4. Calibration

Calibration is a comparison between measurements – one of known magnitude or correctness made or set with one device and another measurement made in as similar a way as possible with a second device. The device with the known or assigned correctness is called the standard. The second device is the device being calibrated. To calibrate the sensors a known reference/standard value is used and the known reference value changes according to the type of sensor being used.

Fig. 3.4 depicts the calibration cylinder. The MQ-7 sensor uses 100 ppm of Carbon Monoxide as the known reference value and the MQ-2 sensor uses 1000 ppm of hydrogen as the known reference value. The calibration procedure's accuracy is based on this reference value and the whole procedure is only as good as the known standard gas. (See Figs. 3.5– 3.7.)

Using the resistance values obtained from the sensor and the resistance of the known standard reference value a ratio is calculated to co-relate with the concentration of the gas present in air. The ratio is calculated using the formula $R1/R0$. Based on the ratio values the concentration can be calculated in ppm using the sensitivity characteristics of each sensor.

Ordinate contains the resistance ratio of the sensor ($R1/R0$). Abscissa is the concentration of gases in ppm. R1 is the resistance of gases in different concentrations and R0 is the resistance of sensor in the known standard reference 1000 ppm of hydrogen. Both the axes are of logarithmic values. The power series equation = $4201.7x^{\wedge}-2.692$ for the chart is obtained using the formula

$$\text{Equation : } y = c * x^b$$

$$c \quad \text{EXP(INDEX(LINEST(LN(y),LN(x)),1,2)).}$$

$$b \quad \text{INDEX(LINEST(LN(y),LN(x)),1).$$

The LINEST function calculates the statistics for a line by using the least squares method to calculate a straight line that best fits the data, and then returns an array that describes the line. LINEST function can be combined with other functions to calculate the statistics for other types of models that are linear in the unknown parameters,

Table 3.3
Sensitivity characteristics of methane in MQ-2.

RATIO	CONC
3	200
2.25	500
1.85	800
1.7	1000
1.45	1600
1.33	2000
1.15	3000
0.95	5000
0.7	10,000

Table 3.5
Sensitivity characteristics of CO in MQ-7.

RATIO	CONC
1.75	50
1	100
0.39	400
0.21	1000
0.092	3000

Table 3.6
Carbon monoxide and its effects.

PPM	Percent	Health effects
0–1	0.0001	None; normal background levels
9	0.0009	None; recommended maximum allowable concentration in short term living area
50	0.005	Maximum exposure allowed in the workplace for 8 h (MSHA)
200	0.02	Mild headache, fatigue, nausea and dizziness
400	0.04	Serious headache – other symptoms intensify. Life threatening after 3 h maximum exposure allowed in the workplace for 15 min (MSHA M/NM)
800	0.08	Dizziness, nausea and convulsions – unconscious within 2 h – death within 2 to 3 h
1600	0.16	Headache, dizziness and nausea – death within 1–2 h
3200	0.32	Headache, dizziness and nausea – death within 1 h
6400	0.64	Headache, dizziness and nausea – death within 25 to 30 min
12,800	1.28	Death within 1 to 3 min

including polynomial, logarithmic, exponential, and power series [12].

The LN function returns the natural logarithm of a number. Natural logarithms are based on the constant e (2.71828182845904). LN is the inverse of the EXP function and the syntax of LN function is LN(number) where number is the positive real number for which the natural logarithm is required.

The INDEX function is used when it is needed to look a reference to a cell within a single range [12]. The EXP function returns e raised to the power of number. The constant e equals 2.71828182845904, the base of the natural logarithm. The syntax of the function is EXP(number) where number is the real number which is used as the exponent. EXP is the inverse of LN, the natural logarithm of number. To calculate powers of other bases, the exponentiation operator (^) is to be used.

$$\text{EXP}(8.343234) == 2.71828182845904^8.343234 = 4201.7$$

The slope of the above line is –2.69208 and hence the power line equation is given by $y = 4201.7 \times e^{-2.69208x}$.

Similarly in an MQ-7 sensor ordinate contains the resistance ratio of the sensor (R1/R0). Abscissa is the concentration of gases in ppm. R1 is the resistance of gases in different concentrations and R0 is the resistance of sensor in 100 ppm of carbon monoxide in clean air. The equation to find the concentration of carbon monoxide present in air is given by $y = 106.13 \times e^{-1.409x}$. The resistance of the sensor at 100 ppm of carbon monoxide in clean air is first calculated and this in turn is used to arrive at the ratio R1/R0. The ratio on substitution in the power equation gives the exact concentration of carbon monoxide present.

3.5. LCD— Arduino circuit

A 16 × 2 LCD display can display 2 lines of 16 characters each. The display unit needs a regulated power supply of 5 V. The Arduino

Table 4.1
Results for carbon monoxide.

	Sample input	Expected output	Output	Deviations
1.	Carbon monoxide	20 ppm	20.23 ppm	1.15%
2.	Carbon monoxide	30 ppm	30.492 ppm	1.64
3.	Carbon monoxide	40 ppm	40.852 ppm	2.13%
4.	Carbon monoxide	50 ppm	51.395 ppm	2.79%

Table 4.2
Results for methane.

	Sample input	Expected output	Output	Deviations
1.	Methane	500 ppm	511.75 ppm	2.35%
2.	Methane	1000 ppm	554.70 ppm	5.47%
3.	Methane	2000 ppm	2164.20 ppm	8.21%

contains a special library specifically for the LCD display unit called the Liquid Crystal Library. It consists of many in built functions which eases the access of the LCD display. The connections between the Arduino and the LCD display are shown in the figure given below.

Algorithm. Display concentration of gases in LCD.

Input: Concentration from arduino

Output: Display in LCD

Step 1: Initialize LCD with LiquidCrystal Library.

Step 2: Create $\alpha(x)$ to access Liquid Crystal Library Functions.

Step 3: if(no_Param($\alpha(x)$)=6)

Use Liquid Crystal function with 6 param

Else

Use Liquid Crystal function with 7 param

Step 4: Initialize begin-> a(t): (16,2)

Step 5: Data: input concentration p(x)

Step 6: write->a(t): p(t)

3.6. GSM system

The GSM modem can't be powered using the Arduino and hence it draws its power from an external power source. It is built in with a voltage regulator and hence it does not need any regulation of power. The GSM cannot be powered with a 9 V battery because it needs more than 1 A of current during transmission. During transmission the GSM modem needs a high amount of current, about 2 A and hence the external power supply should be able to provide it.

1. Rx of Arduino is connected to the Tx of GSM modem.
2. Tx of Arduino is connected to the Rx of GSM modem.

Fig. 3.8 represents GSM Modem to Arduino connection. The Arduino has to be uploaded with the code before it is connected to the GSM modem. The Arduino board consists of two serial ports called the Rx and Tx pin which are connected to the Tx and Rx pins in the GSM modem respectively. The GND pins of both the boards are also connected together. The Arduino transmits the message to be sent using the serial ports. The GSM on receiving the message to be sent fulfills the transmission. The Arduino controls the GSM modem using AT commands. The AT commands are written to the GSM modem using the serial port [13].

Algorithm. Provide GSM alert to user along with their effects.

```



---

Input: Concentration from Arduino

---

Output: SMS Alert

---

Step 1: Initialise GSM with AT commands
Step 2: Data : input concentration p(t)
Step 3: Set GSM to text mode AT+CMGS=1
Step 4: Enter Mobile Number AT+CGMS=n(t)
    If( $\mu(x) \in >$ )
        Enter Message Alert
    Else
        Re- enter n(t)
Step 5: nl(t) -> Ox1A to send SMS

---

    
```

Table 3.6 shows the different concentrations of carbon monoxide and its health effects. The GSM modem is used to send the health effects which each concentration might bring to the user. Based on the concentration messages can also be sent to rescue workers.

4. Result and discussion

The system developed was able to work with a power supply of 5 V while most detectors need a minimum of 24 V for proper functioning. The life of sensor is also stable and with proper calibration has a minimum lifetime of 5 years. The response time for the system is 20–30 s and it does not need any laboratory experiments to predict the concentration of the gases present. The cross sensitivities of the sensor is eased out through an intelligent system. The system is designed in such a way the optimal working conditions are the temperature and humidity of South India. Different working conditions would require different kind of calibration procedure. The concentrations of the gases were predicted with a high level of accuracy and the deviation in percentage was less than 4% for carbon monoxide in low concentration of gases. In methane the deviation is less than 10% for lower concentration of gases. The deviation in percentage was found to be higher in higher concentration of gases [14].

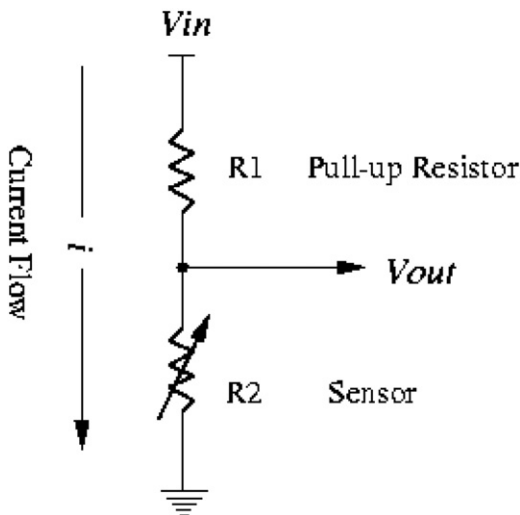

Fig. 3.3. Voltage divider circuit.



Fig. 3.4. Calibration cylinder.

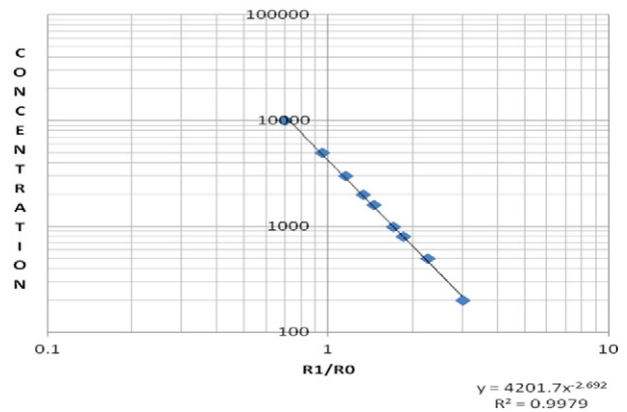

Fig. 3.5. Sensitivity characteristics– MQ-2.

The main advantages of the gas detecting system are that

- It has a high level of accuracy. The accuracy in detection of methane and carbon monoxide is very high.
- It requires very less amount of power and can operate with a power supply of 5 V while other systems need a minimum of 24 V.
- The response time of the system is between 20 and 30 s. The delay is typically set to avoid nuisance alarms.
- Cross-sensitivity is managed between methane and carbon monoxide.
- The detector can be made to go on monitoring the environment while the workers are working due to the low amount of power needed.

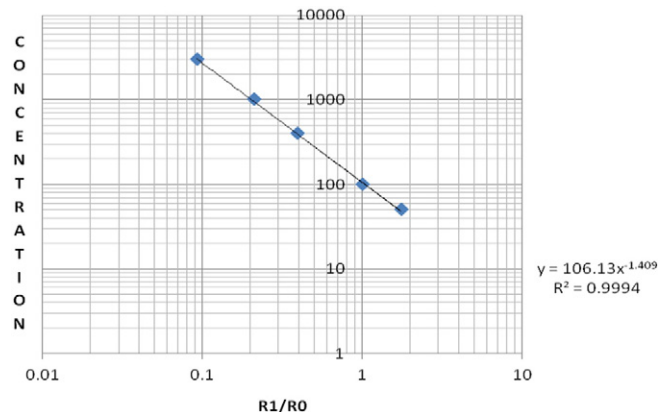

Fig. 3.6. Sensitivity characteristics MQ-7.

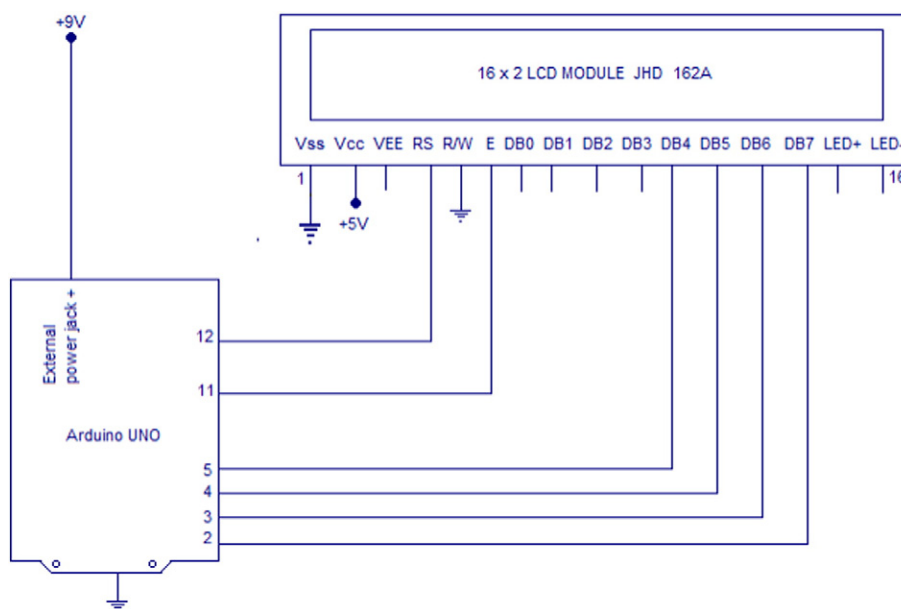

Fig. 3.7. LCD to Arduino circuit.

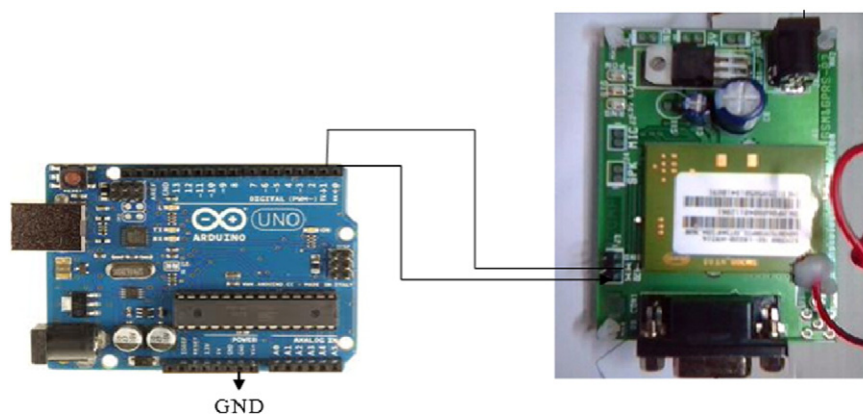

Fig. 3.8. GSM to Arduino Connection.

5. Conclusion

The accuracy of our intelligent sensor system owes to the calibration procedure. This system was able to detect carbon monoxide and methane at the same time adding to its efficiency. The system provides the user with potential health hazards on continuous exposure to a certain concentration of the gas in addition to its existence amount. Thus, the workers using the detector not only get the concentration of the toxic gases present in air but also the health hazards it could bring. The concept of providing the user with the effects it could cause eliminates the effect of illiteracy and carelessness. The system can be enhanced by increasing the number of gases which can be detected by the detector. Thus system can be extended to multiple purposes and can be modified according to the environment by adding or removing the sensors in the system. Thus the detector would have the same goal of detecting toxic gases but would find its applications in many fields.

Conflict of interest

No conflict.

Acknowledgment

We would like to express our thanks to the management of Panimalar Engineering College for executing and validating our proposed system.

Appendix A. Supplementary data

Supplementary data to this article can be found online at <http://dx.doi.org/10.1016/j.sbsr.2016.01.006>.

References

- [1] <http://www.thehindu.com/opinion/op-ed/deaths-in-the-drains/article5868090.ece>.
- [2] <http://www.thehindu.com/todays-paper/tp-national/tp-tamilnadu/their-life-clogged-with-dangers/article1357153.ece>.
- [3] S. Sharma, V.N. Mishra, R. Dwivedi, R.R. Das, Classification of gases/odors using dynamic responses of thick film gas sensor array, *IEEE Sensors J.* 13 (12) (Dec. 2013) 4924–4930.
- [4] W. Khalaf, Sensor array system for gases identification and quantification, in: M.A. Strangio (Ed.), *Recent Advances in Technologies*, InTech, Rijeka, Croatia, 2013.

- [5] D. Lee, H. Jung, J. Lima, M. Leeb, S. Banb, J. Huhc, et al., Explosive gas recognition system using thick film sensor array and neural network, *Sensors Actuators B Chem.* 71 (1–2) (2010) 90–98.
- [6] Ricardo Gutierrez-Osuna, Pattern analysis for machine olfaction: a review, *Microelectron. J. IEEE Sensors J.* 2 (3) (June 2012).
- [7] S. Sharma, V.N. Mishra, R. Dwivedi, R.R. Das, Quantification of individual gases/odors using dynamic responses of gas sensor array with ASM feature technique, *IEEE Sensors J.* 14 (4) (Apr. 2014) 1006–1011.
- [8] A. Özmen, F. Tekce, M.A. Ebeo`glu, C. Taşaltin, Z.Z. Öztürk, Finding the composition of gas mixtures by a phthalocyanine-coated QCM sensor array and an artificial neural network, *Sensors Actuators B Chem.* 115 (1) (2012) 450–454.
- [9] R. Kumar, R.R. Das, V.N. Mishra, R. Dwivedi, Wavelet coefficient trained neural network classifier for improvement in qualitative classification performance of oxygen-plasma treated thick film tin oxide sensor array exposed to different odors/gases, *IEEE Sensors J.* 11 (4) (Apr. 2011) 1013–1018.
- [10] A. Gulbag, F. Temurtas, A study on quantitative classification of binary gas mixture using neural networks and adaptive neurofuzzy inference systems, *Sensors Actuators B Chem.* 115 (1) (2014) 252–256.
- [11] S. Capone, P. Siciliano, N. Bârsan, U. Weimar, L. Vasanelli, Analysis of CO and CH₄ gas mixtures by using a micromachined sensor array, *Sensors Actuators B Chem.* 78 (1–3) (2011) 40–48.
- [12] Li Jing, Shi Yingchun, Chang Wenhui, Bo Xufang, Application research on gas detection with artificial olfactory system, *Sensors Actuators B Chem.* 3 (2012) 233–254.
- [13] <http://arduino.cc/en/reference/homePage>.
- [14] <http://www.seeedstudio.com/depot/datasheet/MQ-2.pdf>.