

Available online at www.sciencedirect.com

Procedia Engineering 14 (2011) 3317–3324

**Procedia
Engineering**

www.elsevier.com/locate/procedia

The Twelfth East Asia-Pacific Conference on Structural Engineering and Construction

Analysis and Design of Disturbed Regions in Concrete Structures.

ATTAULLAH SHAH^{1ab}, EHSANUL HAQ², and SALIMULLAH KHAN³¹ Project Directorate Allama Iqbal Open University Islamabad-Pakistan.² Capital Development Authority Islamabad Pakistan.³ Hazara University Mansehra Pakistan.

Abstract

The ordinary beams theory based on Bernoulli's theorem is not applicable to non linear and non prismatic members, in RC structures like deep beams, pile caps, dapped ended beams and corbels etc. Such structures normally fail due to shear failure rather than flexural failure and cannot be analyzed and designed with the flexural analysis or beam theory. Strut and Tie Model (STM) provides an acceptable analysis and design solution for the non linear and disturbed regions in RC structures. In this research four pile caps, six corbels, three deep beams, and three dapped ended beams, designed on the basis of assumed Strut and Tie Model were tested in the laboratory under monotonic loads. The failure loads were compared with the assumed design loads. It has been observed that STM provides reasonable solution for the design of disturbed region in RC structures. In most of the cases the actual failure loads were reasonably closed to the theoretical design loads. However for generalization of the STM as an alternative design solution, more experimental work is required on non linear and disturbed region.

Keywords: Non linear, Non prismatic, Strut and Tie Model, Shear, Flexure.

1. INTRODUCTION

Non-flexural members are common in reinforced concrete structures and include elements such as deep beams, corbels and nibs, pile caps, connections and the end zones of pre-stressed girders. The ordinary Bernoulli's theorem cannot be applied to such structures, as the plane sections don't remain plain after bending (Saeed *et al*, 2009). The principle of stress analysis or sectional analysis is not valid

^a Corresponding author and presenter: Email: pdaiou@yahoo.com

for such sections. The failure of such structures is normally dominated by shear rather than flexural failure.

The structural components are sometimes divided into Beam regions (B-regions) and Disturbed region (D-regions). In beam regions, it is reasonable to assume that there is a linear variation in strain over the depth of the section, whereas in Disturbed regions, there is a complex variation in strain, occurring near abrupt changes in geometry (geometrical discontinuities) or concentrated forces (statical discontinuities). The extent of D-region spans approximately to one section depth according to St. Venant's principle as shown in Fig.2

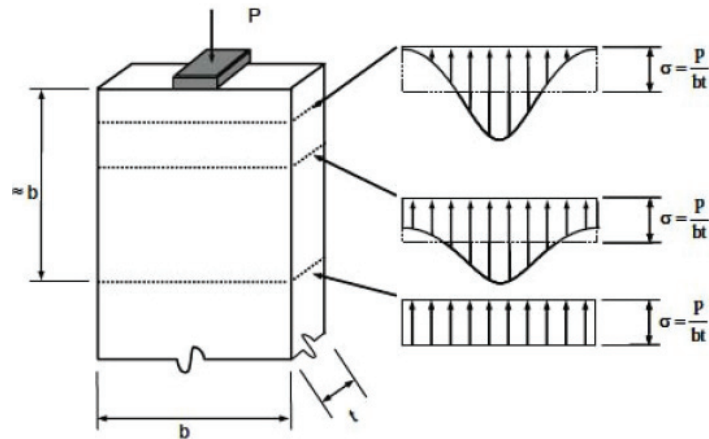

Fig. 2- Illustration of St. Venants principle (FHWA, 2006).

The typical B-regions and D-regions have been shown in Fig. 3

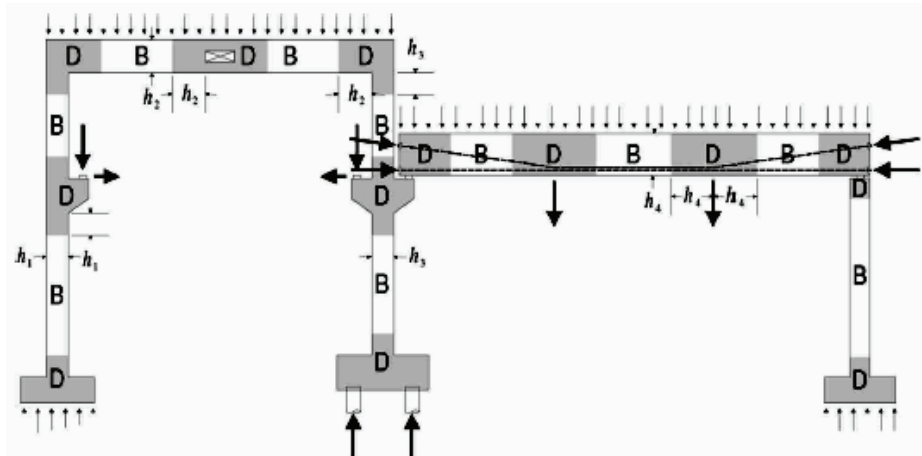

Fig. 3 – Examples of division of B and D regions in common structures (Tjen and Kuchma, 2002).

The strut-and-tie method (STM) is emerging as a code worthy methodology for the design of all types of D-regions in structural concrete (Marti, 1985),(Schlaich,1987), (Schlaich,1991). The truss analogy and Strut and Tie Model (STM) have its root in the pioneering work of Ritter (1899) and Morsch (1909), but

the model has been extensively used for the analysis and design of deep beams, corbels, dapped ended beams, pile caps and beams having openings and discontinuities in the section during last one decade (Saeed *et al.*,2009).

In STM, a load-resisting truss is idealized to carry the forces through the D-region to its supports. The shape of the load resisting truss and its selection depends on the experience of designer, who is free to choose the shape of the load-resisting truss with only limited guidance and constraints. The structure is assumed to be sufficiently ductile so that the load is supported in the same fashion as envisioned by the designer and no part of the truss is over stressed. The compression members of the Truss are called Struts, which resist the compression forces and the struts capacities are determined on the basis of equations proposed by ACI 318-06. These struts are assumed as prismatic, bottle shaped or fan shaped. The tensile members of the truss are called ties, which are reinforced with steel bars. The joints of truss are called “Nodes” (Tjen and Kuchma, 2002).

For the design of complex D-regions, the designer must exercise greater care in the selection of an appropriate idealized truss, application of STM code provisions, the plasticity assumption, and the performance of the structure under service loads.

2. DESIGN STEPS OF DISTURBED REGIONS BY STRUT AND TIE MODEL (STM):

Tjen and Kuchma (2002) have proposed the following steps for the design of disturbed region by STM.

1. Defining the boundaries of the D-region and then evaluating the concentrated,
2. Distributed, and sectional forces that act on the boundaries of this region;
3. Sketching a strut-and-tie model and solving for the truss member forces;
4. Selecting the reinforcing or pre-stressing steel that is necessary to provide the required tie capacity and ensuring that this reinforcement is properly anchored in the nodal zones.
5. Evaluating the dimensions of the struts and nodes such that the capacity of these components is sufficient to carry the design force values; and
6. Providing distributed reinforcement to increase the ductility of the D-region.

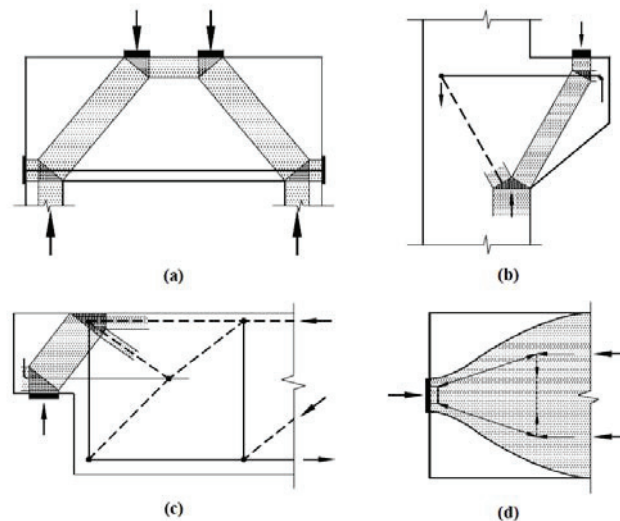

Fig.3- Examples non-flexural members showing typical strut-and-tie models for a) deep beam; b) Corbel; c) Dapped connection; and d) Pre-stressed anchorage zone (ASCE-ACI, 1998).

The equilibrium of the truss with the boundary forces must be satisfied and stresses everywhere in the assumed truss must be below defined code limits as the STM is a lower bound (static or equilibrium) method of limit analysis. Some of the typical Strut and Tie Models have been given for various disturbed regions in Fig.3

The flowchart for design of D-regions is given in Fig.4.

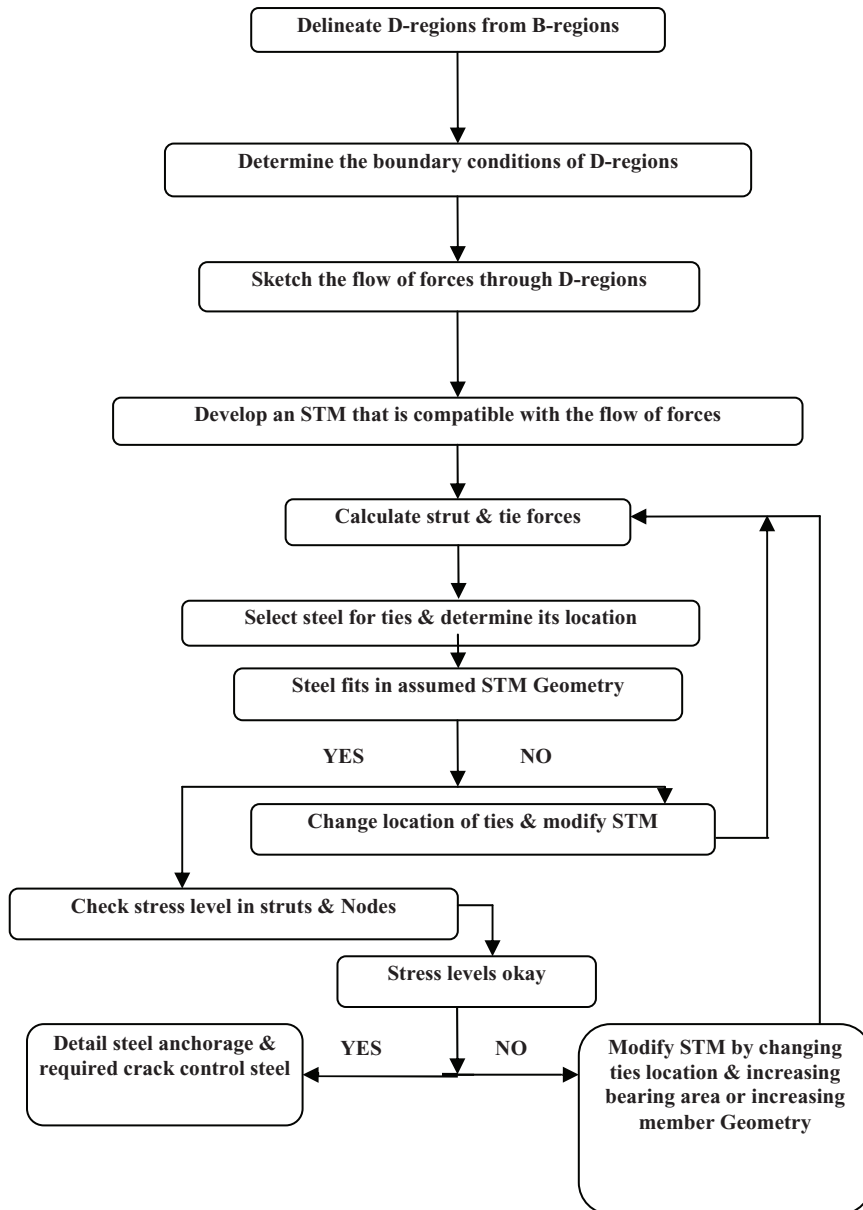
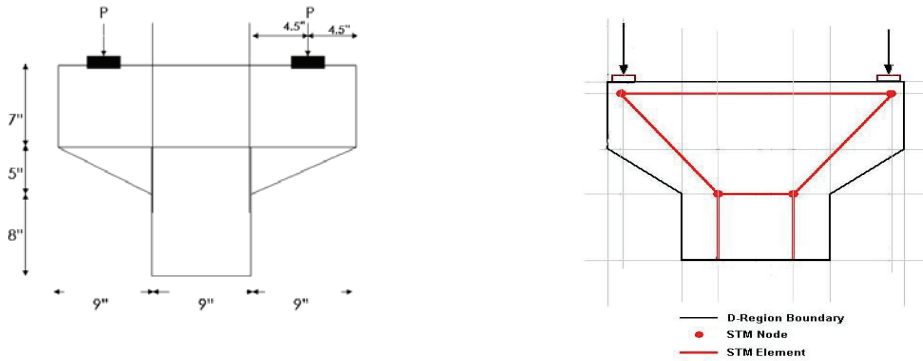

Fig. 4 - Flowchart illustrating STM steps. (Brown *et al.* 2008).

In this research work, the application of STM to the analysis and design of pile caps, corbels and deep beams was explored and full scale members were tested to check the reasonability and accuracy of the STM for design of disturbed regions in concrete.

3. EXPERIMENTAL PROGRAM

A series of research work was initiated at University of Engineering and Technology Taxila Pakistan, in which corbels, deep beams and pile caps were designed against the external assumed loads with the help of STM and later tested under monotonic loads. The geometries of the corbels, beams and pile caps are given in Fig.5.



a. Double Corbel

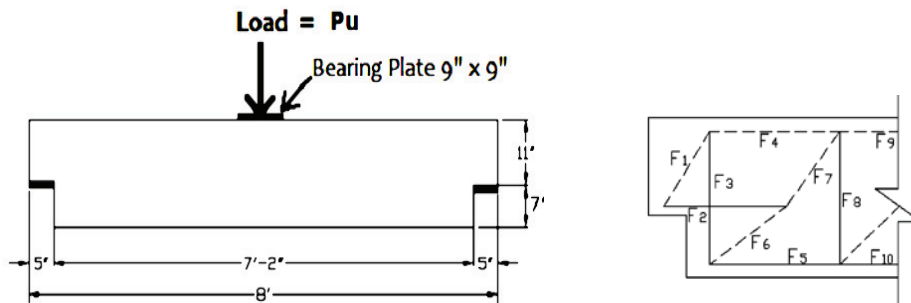

b. Dapped ended beam.

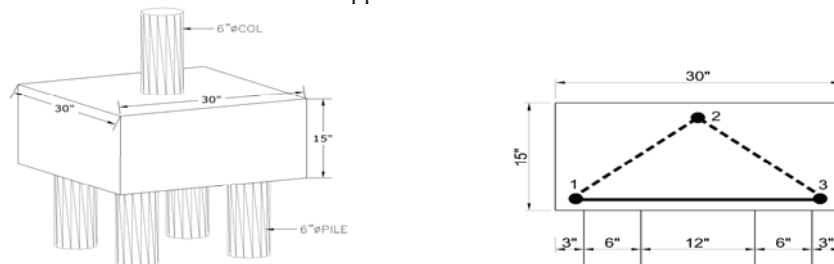

c. Pile caps

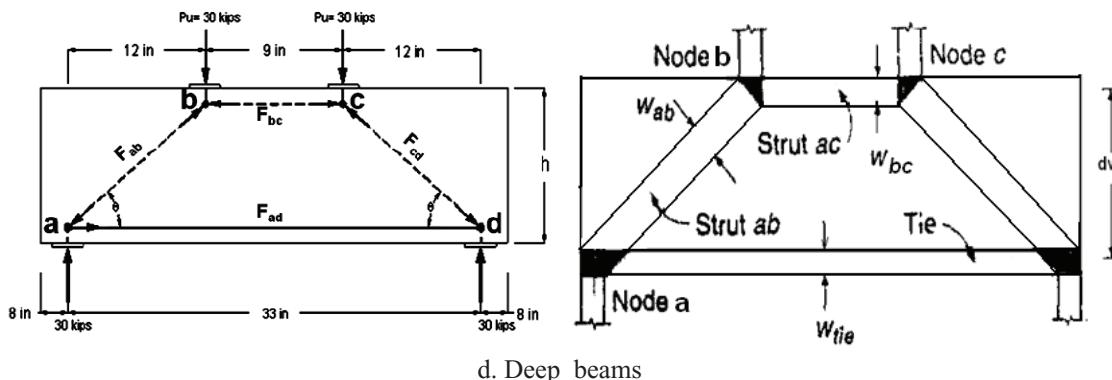

d. Deep beams

Fig.5 Geometries and assumed STM for the disturbed structures tested.

For assumed external loads, the member forces were worked out after resolving the idealized trusses. The compressive forces are normally resisted by the struts of concrete and tensile forces are resisted by longitudinal steel bars. For compressive forces, the allowable struts capacities by ACI318-06 were used to determine the corresponding compressive strengths of struts. For digonal struts, bottled shaped struts have been assumed, whereas for horizontal struts, prismatic struts have been considered to detrmine the compressive strengths of struts. The steel bars required to carry the tensile forces of ties were determined. The details of assumed external loads and actual failure loads are shown in Table 1.

Table 1 Comparison of theretical STM loads and actual failure loads for various structures.

Structure	No of samples tested	Average compressive strength (f_c')	Average Theretical failure load (V_{STM}) (kN)	Average Actual failure load (V_{test}) (kN)	V_{test}/V_{STM}
Pile caps (PC)	04	21	220	251	1.14
Corbles (CB)	06	32	200	225	1.125
Deep beams (DB)	03	35	380	443	1.166
Dapped ended beams (DEB)	03	35	250	315	1.26
				<i>Average</i>	<i>1.17</i>

4. OBSERVATIONS AND DISCUSSIONS:

The tested stcutres having small shear span to depth ratio have mostly failed in shear due to digonal shear cracking. Due to small moment arm, the flexural cracks have not been dominant in theses strcutres. The faliure is more sudden and abrupt,as there are no appreciable flexural cracks in the strcutres prior to developing the digonal cracks, which ultimately caused failure of the strcutres. The design of the stcutres was carriedout with the Strut and Tie Model (STM) and the actaul failure loads after testing have been compared with the theretical loads in Table 1. The detailed calculations have not been produced here due

to shortage of space, however the same can ne obtained from the corresponding author. The actual failure loads when compared with the theretical load carrying capacity were observed slightly on higher side, with mean value of 1.17, which means that the values are 17% more than the theoretical failure loads of the strcutures, when workedout with STM. The selection of appropriate STM is one of the most imporatant and crtical decision on the part of designer, which requires experience and better understanding of the basic structure and its behavior. A comprehinsive report on the disturbed strcutures designed on the basis of STM shall be developed which shall incoporate the design assumptions and other revlant details, which shall be shared with the researchers in due course of time.

Some of the disturbed regions of RC stcutures at failure have been shown in Fig.6.



Fig.6 Typical failure modes of deep pile caps, corbelsl, deep beams and dapped ended beams.

5. CONCLUSIONS

On the basis of comparison of actual and theoretical values of shear strength based on assumed STM of the pile caps, deep beams, corbels and dapped ended beams, it can be infered that the STM provides a useful analysis and design tools for disturbed regions in concrete. However further research work is required for the selection of most optimal Strut and Tie Model (STM) for varios strcutures and applied loads. The slection of the idleaized STM is a a crtical consideration in the use of STM for analysis and design of disturbed region in RC structures. More research is thus required to check the strength of compression struts and nodal zones for assumed STM.

REFERENCES

- [1] ACI-ASCE (1998), “ Recent Approaches to Shear Design of Structural Concrete” Vol.124 pp.1375-1417.
- [2] Ritter, W., “Die Bauweise Hennebique,” *Schweizerische Bauzeitung*, V. 33, No. 7, Feb. 1899, pp. 59-61.
- [3] Mörsch, E (1909)., *Concrete-Steel Construction*, E. P. Goodrich, translation McGraw-Hill, New York, 1909, 368 pp.
- [4] Marti, P (1985)., “Basic Tools of Reinforced Concrete Beam Design,” *ACI Journal, Proceedings* V. 82, No. 1, pp. 46-56.

- [5] Schlaich, J.; Schäfer, K.; and Jennewein, M (1987)., “Toward a Consistent Design of Structural Concrete,” *Journal of the Pre-stressed Concrete Institute*. 32, No. 3, pp. 74-150.
- [6] Schlaich, J., and Schäfer, K., (1991), “Design and Detailing of Structural Concrete Using Strut-and-Tie Models,” *The Structural Engineer*, V. 69, No. 6, Mar. 1991, pp. 113-125.
- [7] Saeed A., Shah.A., (2009) “Evaluation of Shear Strength of High Strength Concrete Corbels using Strut and Tie Model” *The Arabian Journal of Science and Engineering*, Vol.34(2B) pp 27-35.
- [8] Saeed .A., Shah.A, Zaman S., (2009), “ Evalaution of the shear strength of four piles caps, using Strut and Tie Model” *Journal of Chinese Institute of Engineers* Vol.32(2) pp.243-250.
- [9] M.D. Brown and Oguzhan Bayrak.,” Design of Deep Beams Using Strut-and-Tie Models—Part II: Design Recommendations” *ACI Structural Journal*, V. 105, No. 4, July-August 2008 pp 142-149.
- [10] Tjen N. Tjhin and Daniel A. Kuchma., “Computer-Based Tools for Design by Strut-and-Tie Method: Advances and Challenges” *ACI Structural Journal*, V. 99, No. 5, September-October 2002. Pp 586-594.
- [11] M.D. Brown, C.L. Sankovich, O.B,James, O. J.E. Breen, S.L. Wood (2006), “ Design for Shear in Reinforced Concrete Using Strut and Tie Models” Report No. FHWA/TX-06/0-4371-2, pp 3