

Available online at [www.sciencedirect.com](http://www.sciencedirect.com)**SciVerse ScienceDirect**

Procedia Engineering 39 (2012) 182 – 191

**Procedia  
Engineering**[www.elsevier.com/locate/procedia](http://www.elsevier.com/locate/procedia)

XIIIth International Scientific and Engineering Conference “HERVICON-2011”

## Balancing With the Presence of a Rub

Nicolas PETON<sup>a</sup>, a\*<sup>a</sup>*GE Energy, Measurement and Control Solutions, 2 rue de Flandre, La Chapelle sur Erdre 44241, France*

---

### Abstract

During commissioning of a cogeneration plant the air cooled generator can not be run up to synchronization speed because of high 1X vibration during startup. Several attempts were done by the commissioning team to balance the rotor but proven ineffective. Article presents the vibration analysis performed by GE MDS Engineer. As a result of the analysis it was concluded the high levels of synchronous vibration are caused by thermally induced bow because of rub in the new type of seals installed in generator casing. The seals were removed for test and the generator was started successfully. The next part of the article discusses the differences between Newkirk and Morton type thermally induced bows as they can be observed in the machinery diagnostics during field analysis

© 2011 Published by Elsevier Ltd. Selection and/or peer-review under responsibility of Sumy State University. Open access under [CC BY-NC-ND license](https://creativecommons.org/licenses/by-nc-nd/4.0/).

*Keywords:* Rubbing; balancing; rolling phase; thermal phenomenon; Newkirk/Morton effect.

---

### 1. Discussion

Machine train as shown in figure 1 consists of Steam Turbine driven, Gearbox and Generator. The air cooled generator is coming from another site where, according to maintenance data it was running with low vibration levels. Because of damages caused by shortcut in the stator the rotor was in overhauled and later it was installed in current location. During the overhaul no works were done on the rotor so balancing condition should be unchanged.

Each of the machine train's bearing is monitored by displacement transducers mounted on the machine casing in a plane (XY) perpendicular to the rotor axis of the machine to observe radial motion of the shaft. The XY pairs of non-contacting proximity probes are mounted at 45-degrees left (Y-probe) and 45-

---

\* Corresponding author. Tel.: +33-611408614.

E-mail address: [nicolas.peton@ge.com](mailto:nicolas.peton@ge.com)

degree right (X-probe). The machine train layout is shown in figure 1. The driver shaft rotates clockwise, when viewed from the driver to the driven. The driven machine shaft rotates counter clockwise.

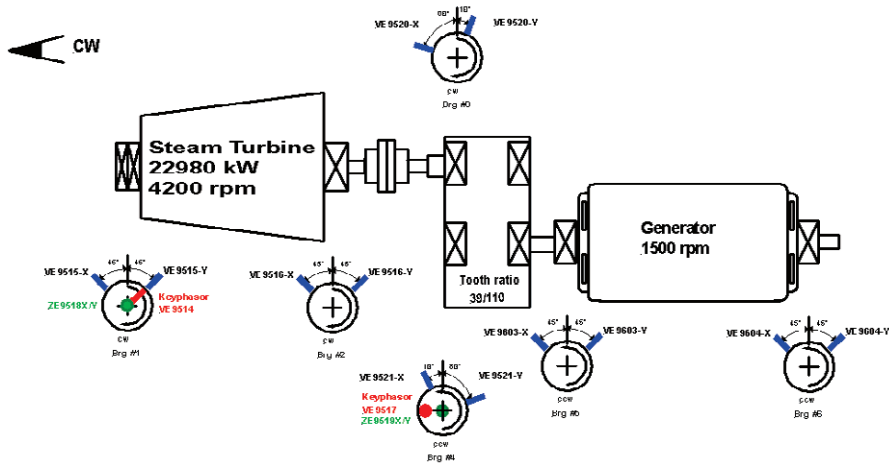

Fig. 1. Machine train layout

During each startup very high vibration levels on the DE and NDE bearings of the generator was noticed and synchronization speed couldn't be reached. Several attempts were done by the commissioning team to balance the rotor but proven ineffective. DCS data from the customer on figure 2 show two different attempts.

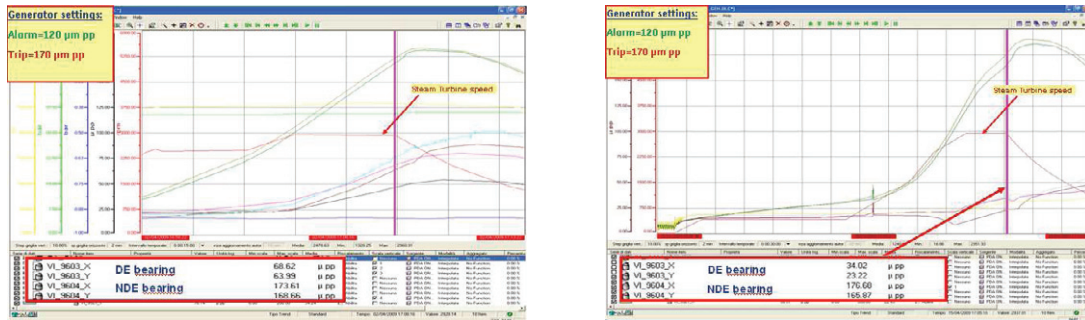

Fig. 2. Customer data showing high vibrations on generator bearings while trying to reach nominal speed. Data show two attempts to reach synchronization speed within two weeks

The DCS trends are showing only overall vibration trends so diagnostic system need to be used to obtain more informative characteristics. A first set of vibration data was recorded using ADRE 408 DSPi (Dynamic Signal Processing Instrument) connected to vibration signals from the existing Bentley Nevada's 3500 Series vibration monitor system. During the coast down the vibration level exceeded the vibration level observed while running up. Synchronization speed couldn't be reached. The following facts can be observed from analysis of the data as in figure 3.

- An hysteresis between run up and coast down is noticed on the Bode plots figure 3: during coast down the vibration level observed is much higher than during the run up and the shape of coast down

characteristics is unusual. Indeed for a speed below the first resonance the shape of the 1X amplitude versus the speed should be parabolic as shown on figure 4 where typical Bode plot of a rotor system is described

- Though the critical speeds were unknown no phase change of 180° during speed up was observed suggesting no critical was crossed

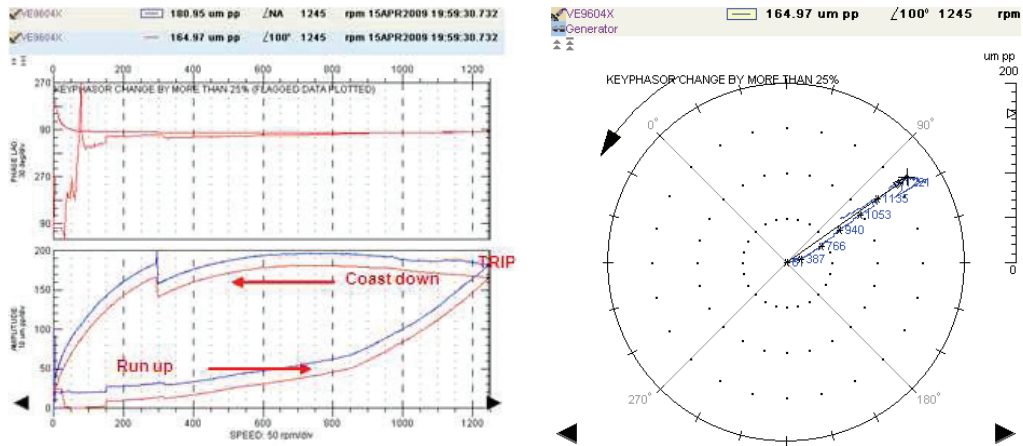

Fig. 3. Direct and 1X Bode plots with 1X polar plot for NDE generator bearings during run up and coast down after a trip because of high vibrations

Figure 5 shows Bode plot showing resonance of an ideal single mass rotor system (Jeffcott rotor). The upper plot shows the phase lag versus rotor speed. The lower plot shows the amplitude of vibration versus rotor speed. When rotor speed nears the rotor system natural frequency the amplitude of vibration increases and a phase shift of 180° occurs. As the rotor speed passes beyond the natural frequency the amplitude decreases

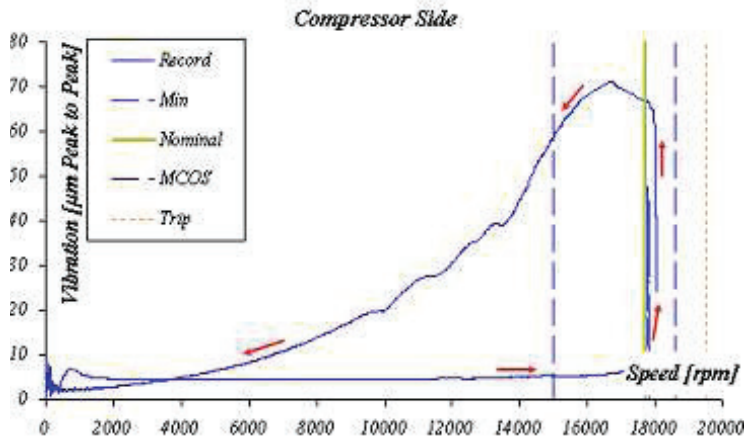

Fig. 4. Vibration hysteresis in Bode plot. Typical behavior for a spiral vibration [1]

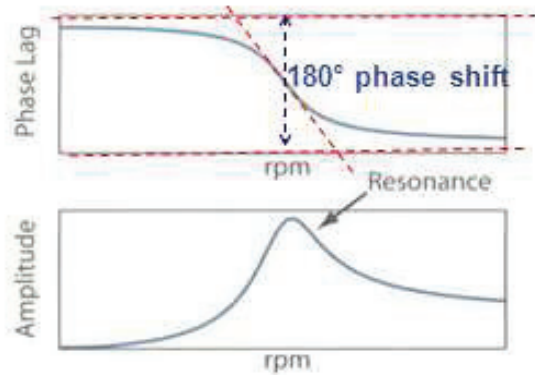

Fig. 5. Bode plot of an ideal rotor system [2]

The Bode plots and polar plots on figure 6 shows the vibration level is increasing at constant speed suggesting something else rather than response to unbalance. If during run up thermal bending occurs at a particular speed the thermal unbalance will result in an increase of synchronous rotor vibration. A quick reversal of speed (because of a trip for example) will result in a hysteresis loop (see figure 4) because of the time constants associated with the thermal phenomenon. Polar plots on figure 5 and trend plot on figure 7 show those changes in amplitude and phase while the speed is constant

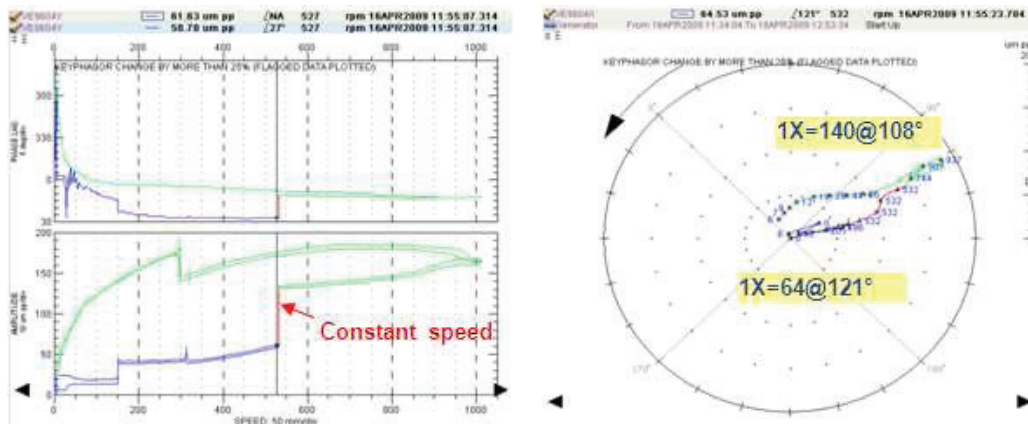

Fig. 6. Direct and 1X Bode plots with 1X polar plots for NDE generator bearings during run up/coast down with a step at 500 rpm showing vibration increase and phase change

Once the machine dropped below a certain speed (100rpm) the vibration levels decreased rapidly indicating that if there would have been any residual unbalance this would have been still noticeable. This abrupt-speed related absence of vibration is also suggesting the problem isn't a balance related phenomenon. Below this speed 1X forces because of thermal unbalance drop because the contact disappear and 1X vibration go back to “no bow” response

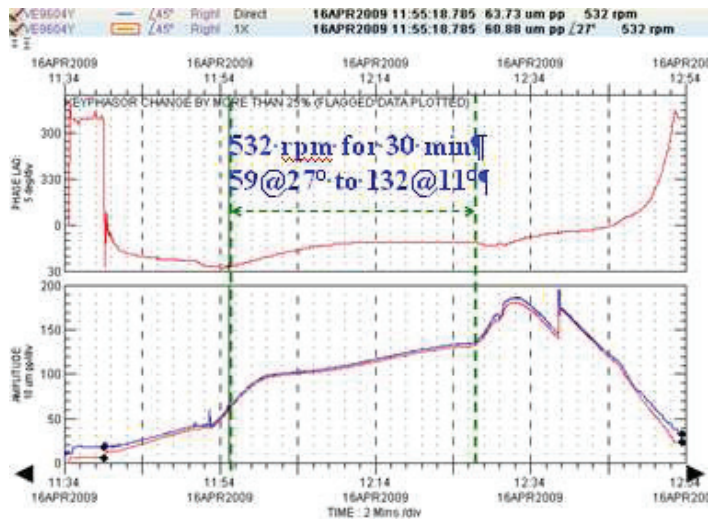

Fig. 7. Direct and 1X trend plots for NDE generator bearings during run up/coast down with a step at 500 rpm showing vibration increase and phase change

The shaft movement is composed of 1X (shaft rotative speed) vibration frequencies (see full waterfall plots figure 8). Even as the turbine is coasting down the vibration level remains with a dominant 1X forward component

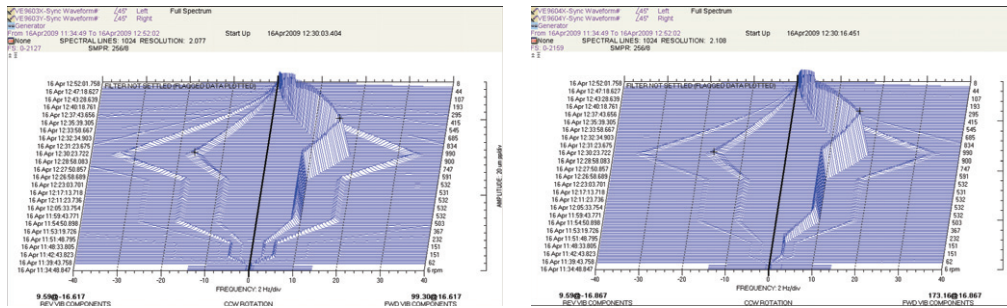
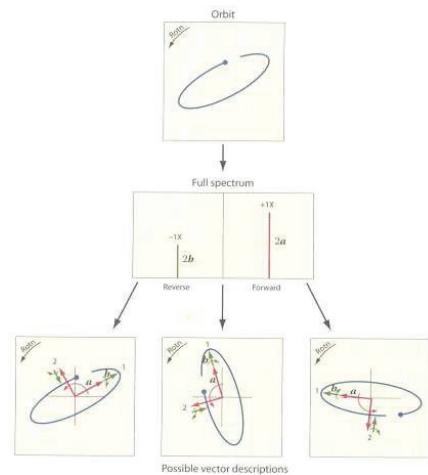

Fig. 8. Full Waterfall plot of DE and NDE generator bearings showing dominant 1X forward vibration component (circular orbit)

The Full spectrum is a tool that allows the user to examine the shape and precession of an orbit at any frequency with the measure frequency range. The relative magnitude of the forward and reverse components can be used to determine orbit shapes as well as precession. Most forcing functions applied to rotating machinery are acting with or in the same direction as rotor rotation. Rotor to stationary part rubs are example of forces applied to the rotor opposite to the direction of rotation. This type of force can introduce precession forces and reverse precession orbital motion.

The presence of reverse components in the full spectrum plot does not always imply that reverse precession forces are present. For example, a mass unbalance force on the rotor with an anisotropic bearing stiffness; e.g. elliptical bearings. The response of the system at the plane of measurement will yield an elliptical orbit. The full spectrum plot will define the orbit shape with a display of reverse and forward components at the rotor frequency (1X). However, this does not imply that forward and reverse forcing functions are present. Mass unbalance (centrifugal force) is an integral part of the rotor geometry and produces only a forward direction force



Conclusion of the analysis of the data showed that it wasn't a balancing issue but rather a rub. The localization of the rub can be predicted from analysis of machine design. In generators the clearances are big when compared to fluid machines so the typical localization of rub are machine seals (air seals in the housing) or the bearing oil seals. An inspection of the NDE and DE bearings of the generator showed the machine seals had indeed sustained a heavy rub. Corresponding marks were found on the shaft. Picture on figure 10 shows the seals as they were found after opening the bearings

Decision was then made to run the unit again without those air seals to confirm diagnostics. figure 9 shows the difference in vibration level before the issue and after the issue confirming the rub on the machine seals. The machine could then be started up to full speed no load with no vibration issue

Following this founding decision was made by the manufacturer to look for new machine seals. At the time GE was on site those new air seals weren't available and so no new data are available

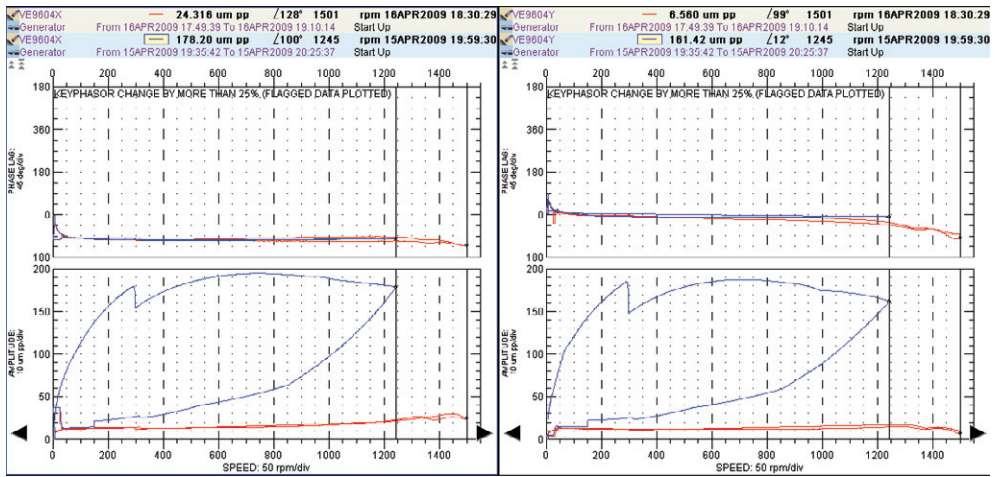

Fig. 9. 1X Bode plots showing the difference in vibration level before (in blue) and after (in red) the issue

To prevent leakage to the inside of the machine due to negative pressure or high air velocity, the housing has an integrated air or machine seal. Floating labyrinth seals catch and divert oil mist and vapors away from the rotating shaft.

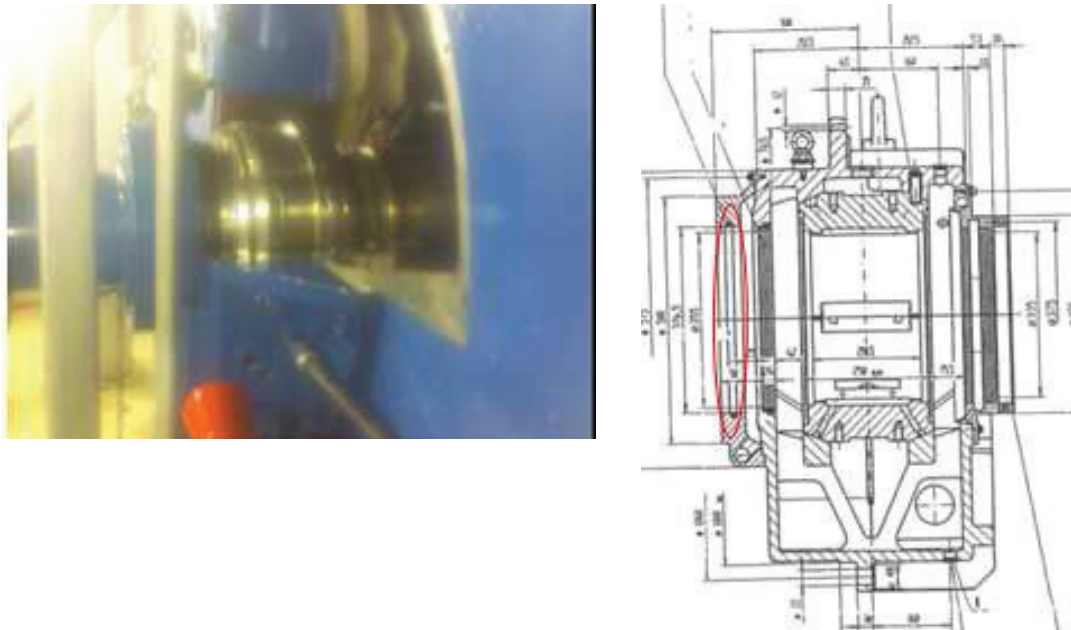

Fig. 10. Picture and drawing showing seals details on generator bearings (air cooled generator)

## 2. Difference between Newkirk and Morton effect

There is another phenomena with identical vibration pattern (1X rotating) but without rub mechanism: it is the Morton effect.

Newkirk effect is a spiral phenomenon that can be observed in various types of rotating machines. It is due to a vibration-induced hot spot on the shaft surface generated by friction due to a “soft” rubbing of the shaft to stationary parts (labyrinth seals, seal rings, hydrogen seals or brushes on slip rings).

Morton effect is also a spiral phenomenon but in this case the vibration induced hot spots takes place in radial fluid film bearings. Because of this, machine showing this phenomenon are essentially limited to high speed flexible rotors that have relatively large overhung masses.

The Morton effect occurs when the journal is executing a synchronous orbit around the bearing center. Because of the load the center of the shaft isn't at the center of the bearing. If there is no vibration all the points on the journal surface will follow the same way: there is no area exposed to a different oil thickness.

Some corrective actions for Morton effect can be: limit the “design” speed, reduce of overhung moments, change bearing clearances, reduce bearing length, change bearing type or geometry, increase specific bearing loading and eccentricity, change shaft material, change lubrication oil viscosity or increase oil flow.

In case of a synchronous vibration the motion of the center of the shaft will be an orbit and will move from O to O' for a rotation of 180°.

A will move to A' and B to B'. A will always be at minimum oil thickness than B. In other words it is always the same point on the shaft which is subject to maximum (A) friction and minimum friction (B).

Thus this difference will lead to temperature gradient across the journal and a hot spot will occur.

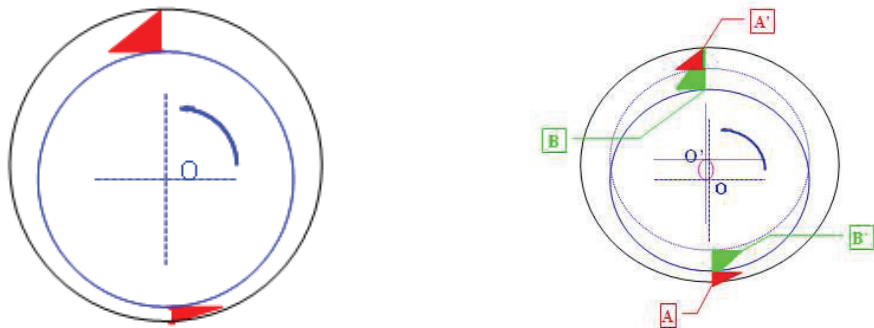

Fig. 11. Drawing showing motion of the center of the shaft when moving from O to O'



Parameter	Newkirk Effect	Morton Effect
Rotor Motion	synchronous whirl	synchronous whirl
Overhung Configuration	not required	required
Mechanical Unbalance	in phase with hot spot	out of phase with hot spot
Cause of Hot Spot	rotor-to-stator rub	differential viscous shearing
Location of Hot Spot	outside bearing	within bearing

Fig. 12. Comparison between the Newkirk effect and the Morton effect

In the following two models (in between bearing and overhung configuration) will be studied. For the case of a rub in between bearings the hot spot location could be a seal between both bearings. Because of the thermal expansion of shaft material at the point of run contact (local heating) the shaft bows and gravity center of the shaft moves in the direction of the hot spot angular position.

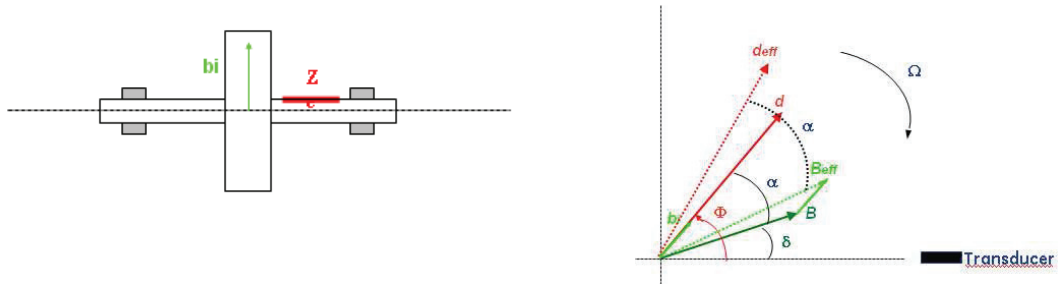

Fig. 13. In between bearing configuration

Initial unbalance **B** causes the response **d** located at angle  $\alpha$  lagging the initial unbalance location. In this case the center of gravity is shifted in the same direction of the displacement and we have a new unbalance **bi** that will be added (vector adding) to the initial unbalance to create a final unbalance **Beff**. In fact we are adding bowing at the point of contact **F**. It is assumed that the additional “unbalance” is small when compared to original one. So the angle of the resultant unbalance moved slightly in opposite direction to rotation. So the response **deff** is moved from the same angle if the speed and the stiffness didn't change ( if stiffness changes, which is likely to happen, then there would be a new phase lag). The phase lag is increasing and the rotation direction of the 1X vector is reversed.

In the case of overhung configuration the Hot Spot could be a seal between both bearings or the bearing itself. Practically speaking... What can be rubbing in bearing? Light rubbing... It also can be only seal.. Because of the thermal effect the gravity center of the overhung moves in the direction opposite of the generatrice where the hot spot is located. The same method as before will give us a new response that is moving in the same direction of rotation of the shaft.

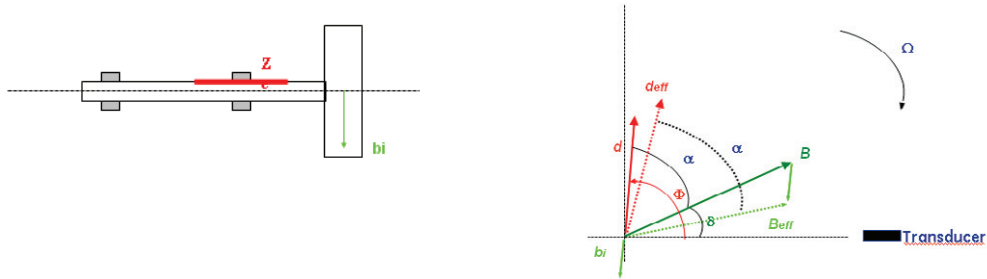

Fig. 14. Overhung configuration

Because of the initial unbalance  $\mathbf{B}$  we have a response  $\mathbf{d}$  located at  $\alpha$  degree lagging. In this case the center of gravity is shifted in the opposite direction of the displacement and we have a new unbalance  $\mathbf{bi}$  that will be added to the initial unbalance  $\mathbf{B}$  to create a final unbalance  $\mathbf{B_{eff}}$  (same direction of rotation). The phase lag is decreasing and the rotation direction of the 1X vector is forward.

## References

- [1] Schmied J, Pozivil J, Walch J: *Hot spots in turboexpander bearings, Case History, Stability Analysis, Measurement and Operational Experience*. Proceedings of ASME Turbo Expo 2008 Power for Land, Sea and Air, June 9-13 2008, Berlin, Germany.
- [2] Bently D.E, Hatch C.H: *Fundamentals of Rotating Machinery Diagnostics*. Bently Pressurized Bearing Company, (2002).
- [3] De Jongh F.M, Morton P.G: *The synchronous instability of a compressor rotor due to bearing journal differential heating*. Journal of Engineering for Gas Turbines and Power, Vol. 118, (1996), pp. 816-823.
- [4] Muszynska A: *Thermal rub effect in rotating machines*. Orbit 3/93.
- [5] Eckert L, Schmied J, Ziegler A: *Case History and Analysis of the spiral vibration of a large turbogenerator using three different heat input models*, Alstom and Delta JS AG. 7th IFToMM conference on rotordynamics, (2006), Vienna, Austria.