

MutS α Binds to and Promotes Synapsis of Transcriptionally Activated Immunoglobulin Switch Regions

Erik D. Larson,^{1,*} Michelle L. Duquette,¹
W. Jason Cummings,¹ Raphael J. Streiff,¹
and Nancy Maizels^{1,2}

¹Departments of Immunology and Biochemistry

²Molecular and Cellular Biology Graduate Program
University of Washington School of Medicine
1959 N.E. Pacific Street, Box 357650
Seattle, Washington 98195

Summary

Immunoglobulin class switch recombination joins a new constant (C) region to the rearranged and expressed heavy chain variable (VDJ) region in antigen-activated B cells (Figure 1A) (reviewed in [1, 2]). Switch recombination is activated by transcription of intronic, G-rich and repetitive switch (S) regions and produces junctions that are heterogeneous in sequence and position in the S regions. Switch recombination depends upon the B cell-specific cytidine deaminase, AID, and conserved DNA repair factors, including the mismatch repair heterodimer, MutS α (MSH2/MSH6). In mice, ablation of *Msh2* or *Msh6*, but not *Msh3*, decreases levels of switch recombination and diminishes heterogeneity of switch junctions [3–7]. Here, we demonstrate that MSH2 associates with transcribed S regions in primary murine B cells activated for switch recombination. Electron microscopic imaging reveals that MutS α binds in vitro to DNA structures formed within transcribed S regions and mediates their synapsis. MutS α binds with high affinity to G4 DNA formed upon transcription of the S regions and also binds to U-G mismatches, initial products of DNA deamination by AID. These results suggest that MutS α interacts with the S regions in switching B cells to promote DNA synapsis and recombination.

Results and Discussion

MSH2 Associates with Transcribed S Regions in Switching B Cells

We assayed association of MSH2 with S regions in vivo by chromatin immunoprecipitation (ChIP), monitoring recovery of S γ 3 switch regions by duplex PCR relative to a triosephosphate isomerase (TPI) control. Primary murine splenocytes were cultured with lipopolysaccharide (LPS) to induce switching from IgM to IgG3 (Figure 1B). In chromatin prepared from these switching B cells, normalized enrichment of S γ 3 sequences after immunoprecipitation with anti-MSH2 antibodies was 1.5-fold (Figure 1C, top); and there was no enrichment of S γ 3 sequences after immunoprecipitation from the murine pre-B cell line PD31, which proliferates robustly but does not switch (Figure 1C, bottom).

Specific association of MSH2 with transcriptionally

activated S γ 3 regions was assayed by serial immunoprecipitation or “ChIP/reChIP” of chromatin from LPS-cultured B cells. The first IP was with an anti-acetylated histone H4 antibody to enrich for transcribed genomic regions, and the second was with anti-MSH2 antibodies. The normalized enrichment of S γ 3 sequences was 1.8-fold (Figure 1D). These enrichment levels, measured in a heterogeneous population of primary mammalian cells, compare well with observations in other systems. For example, after induction of HO endonuclease cleavage in a synchronized *S. cerevisiae* culture, a 3.5-fold maximal enrichment of recombination factors including Rad51p is evident at the HO cleavage site [8]. We conclude that MSH2 associates with transcribed S γ 3 regions in B cells switching to IgG3, consistent with participation of MSH2 in the recombination mechanism.

MutS α Binds In Vitro to G4 DNA and U-G Mismatches

To identify potential DNA targets for MutS α at activated S regions in vivo, we assayed binding of purified, recombinant human MutS α (see Figure S1A available with this article online) to substrates representing activated S regions. Transcription of S regions causes formation of G loops in which a stable, cotranscriptional RNA/DNA hybrid formed on the C-rich strand prevents reannealing of the DNA duplex after transcription, and the G-rich strand includes regions of G4 DNA interspersed with single-stranded DNA [9]. In G4 DNA, four strands associate, stabilized by Hoogsteen bonding between planar arrays of guanines, or G-quartets. MutS α bound tightly to G4 DNA formed from the TP oligonucleotide, which carries a consensus sequence from a murine S region (apparent $K_D = 1$ nM) (Figures 2A and 2B), and to G4 DNAs formed from other G-rich sequences (Figure S1B). MutS α binding to G4 DNA is therefore structure specific not sequence specific.

AID converts C to U in transcribed regions, thereby creating U-G mismatches (reviewed in [10, 11]). MutS α bound to a synthetic heteroduplex carrying a U-G mismatch with affinity (apparent $K_D = 32$ nM) greater than its affinity for homoduplex DNA (Figures 2A–2C). Human MutS α has also been shown to bind UU-GG double mismatches (apparent $K_D = 24$ nM) [12]. MutS α did not specifically bind other predicted intermediates in the AID/UNG pathway, including duplex oligonucleotides carrying an abasic site opposite G or duplexes cleaved at an abasic site produced by combined action of UNG and APE-1 (not shown).

Binding to G4 DNA resulted in formation of higher-order complexes, even at very low MutS α concentrations (≤ 2 nM) (Figure 2A). Higher order complexes were also observed upon binding of MutS α to T-G and U-G heteroduplexes at higher protein concentration (Figure 2A). Homologs of MutS α can oligomerize in vitro [13, 14] but at concentrations three orders of magnitude greater than those used in the binding assays shown. Thus, the higher order complexes are unlikely to reflect

*Correspondence: edlarsen@u.washington.edu

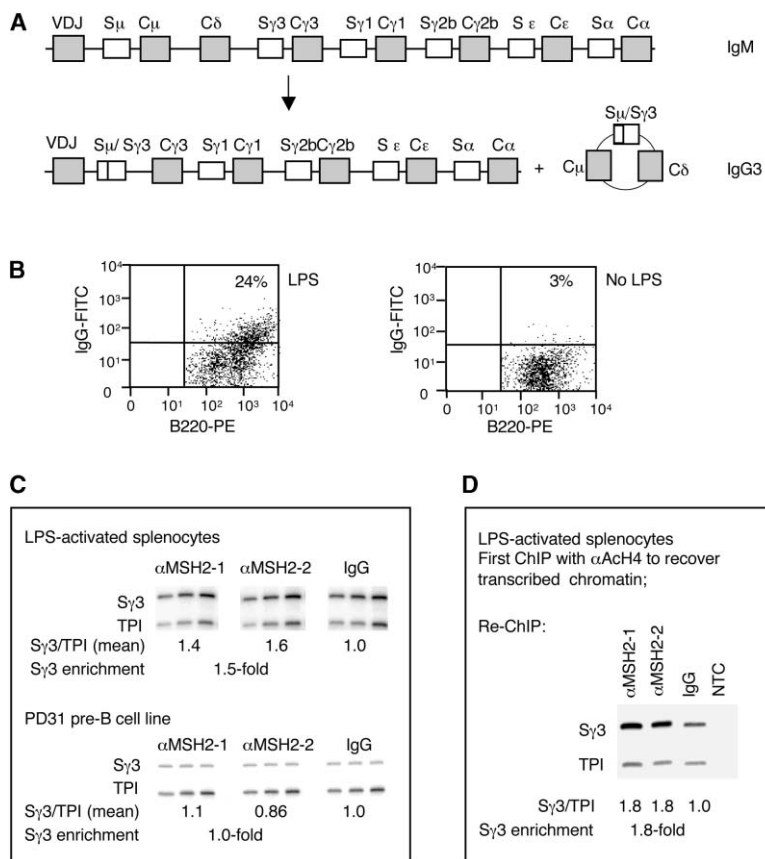

Figure 1. MSH2 Associates with the S Regions in Switching B Cells

(A) Class-switch recombination from μ to γ 3. The rearranged murine heavy chain locus is shown, including the rearranged variable region (VDJ) and proximal switch (S) and constant (C) regions. Recombination joins a new constant region (C γ 3) to the expressed variable region, rejoining chromosomal DNA and generating a circle containing the excised sequences (bottom).

(B) Flow cytometry of LPS-activated murine splenocytes. Splenocytes were cultured for 72 hr with (left) or without (right) LPS, stained with anti-B220 antibodies (X-axis), specific for B cells, and anti-IgG (y axis), and analyzed. The percentage of cells that have switched is indicated in the upper right quadrant of each plot.

(C) Enrichment of S γ 3 regions in MSH2 bound chromatin. Native gel electrophoresis of duplex PCR products amplified with primers specific for the S γ 3 switch region (S γ 3) or the triosephosphate isomerase gene (TPI) from immunoprecipitated chromatin templates. Left, products of amplification from immunoprecipitations with anti-MSH2 antibodies (α MSH2-1, Oncogene, and α MSH2-2, Santa Cruz Biochemicals) or polyspecific rabbit IgG (IgG) of chromatin from splenocytes cultured for 72 hr with LPS (top) or PD31 pre-B cells (bottom); serial 2-fold dilutions of template are shown. S γ 3 enrichment was calculated as the recovery ratios of S γ 3/TPI amplicons normalized to the IgG control for nonspecific immunoprecipitation: anti-MSH2 (S γ 3/TPI)/

IgG (S γ 3/TPI). Mean enrichment is shown below the gel; recovery is tabulated in Table S1.

(D) Enrichment of transcribed S γ 3 regions in MSH2 bound chromatin. Products of amplification of chromatin from LPS-activated splenocytes immunoprecipitated first with anti-acetylated H4 antibodies followed by anti-MSH2 antibodies. NTC, no template control. Other notations as in (C).

nonspecific aggregation, which raised the possibility that they might be relevant to the physiological function of MutS α . The observed higher order complexes (Figure 2A) could represent multiple MutS α heterodimers bound to one DNA molecule or interactions between MutS α heterodimers bound to different DNA molecules.

MutS α Binding to G4 DNA Is ATP Resistant

Mismatch repair by MutS α is governed by ATP binding and hydrolysis, and MutS α does not stably bind heteroduplex DNAs in the presence of ATP (reviewed in [15]). Mutation of the *Msh2* ATPase has only modest impact on class-switch recombination [16], prompting us to ask if G4 DNA binding is sensitive to ATP. MutS α binding to G4 DNA binding was stable in ATP concentrations as high as 1 mM, in contrast to heteroduplex binding (Figures 2D and S2A). MutS α binding to another DNA structure, the Holliday junction, was also resistant to ATP (Figures 2D and S2B) [17]. This difference in ATP sensitivity suggests that MutS α may have distinct modes of binding and responding to DNA structures and heteroduplexes. These results raise the possibility that the ATPase-independent component of MutS α function in switch recombination may involve binding to DNA structures.

MutS α Binds to G Loops within Transcribed S Regions

To study the interaction of MutS α with individual transcribed S regions, we used electron microscopy to image complexes of MutS α with transcribed S μ or S γ 3 regions in plasmid templates. S region transcription resulted in formation of distinctive G loops (e.g., Figure 3A), as previously reported [9]. MutS α is very large (\sim 250 kDa) and was clearly visible bound to the G loops (e.g., Figure 3B). The fraction of bound G loops was dependent upon the concentration of MutS α , reaching 42% in a typical reaction containing 5 nM MutS α and 17 nM DNA. MutS α bound only to the thinner filament, which corresponds to the G-rich strand [9], and not to the thicker filament, which contains the RNA/DNA hybrid, nor to the duplex region of the plasmid (e.g., Figure 3B). Inclusion of a 10-fold molar excess of synthetic G4 DNA decreased the percentage of molecules bound from 42% to less than 4% (1 of 27 molecules) (not shown). The high affinity of MutS α for G4 DNA (Figures 2 and S1B) suggests that G4 DNA is a binding target for MutS α within the G loops.

MutS α Promotes S Region Synapsis

Strikingly, MutS α not only bound to G loops but also promoted interactions between them, effectively allowing

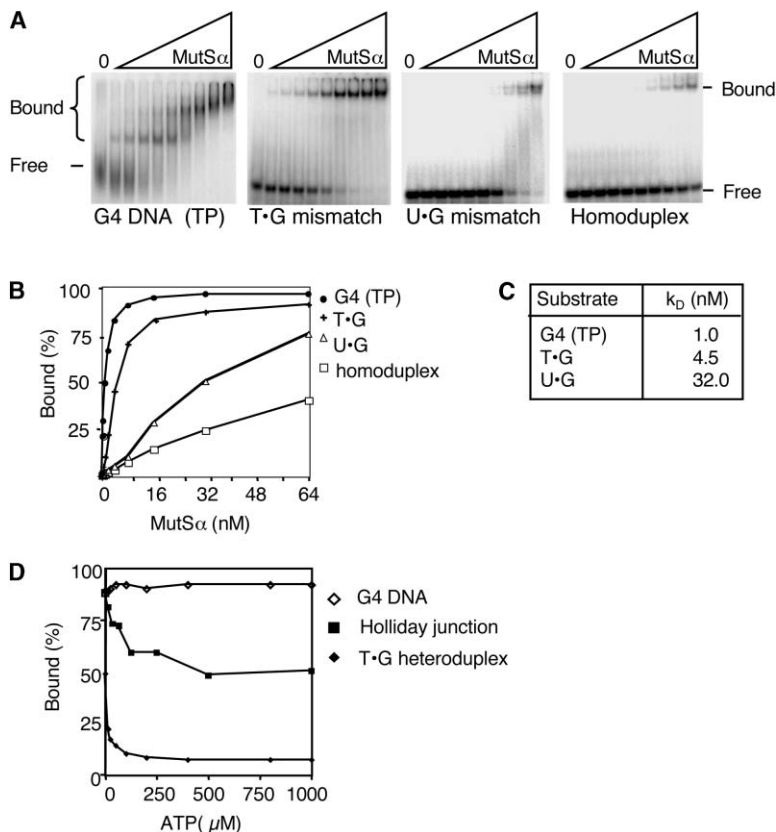

Figure 2. MutS α Specifically Recognizes G4 DNA, and Binding Is ATP Resistant

(A) Gel mobility shift analysis of hMutS α (0.25–64 nM) bound to ³²P-labeled oligonucleotides containing G4 DNA formed from the TP oligonucleotide (S γ 2b consensus sequence), heteroduplexes containing a single T·G or a single U·G mismatch, or a homoduplex. Free DNAs and MutS α bound complexes are indicated.

(B) Binding to G4 DNA, T·G and U·G mismatch heteroduplexes, and homoduplexes as a function of MutS α concentration, quantified by phosphorimager.

(C) Apparent affinities of MutS α binding to G4 DNA or heteroduplexes carrying T·G or U·G mismatches.

(D) ATP resistance of MutS α binding to G4 DNA, Holliday junctions, and T·G mismatch heteroduplexes, quantified by phosphorimager.

two DNA molecules to synapse (e.g., Figure 3C). In a representative reaction, 27% of molecules containing G loops were synapsed in the presence of MutS α (32 of 120 molecules). No synapsis was observed if BSA was substituted for MutS α (not shown). In all cases, the interactions between synapsed molecules localized to the G loops, and involved the thinner filaments of the G loops, corresponding to the G-rich DNA strand (Figure 3C). Inclusion of a 10-fold molar excess of synthetic G4 DNA efficiently inhibited synapsis by MutS α so that only 1% (2 of 200) of molecules that contained G loops were synapsed (not shown). Competition by synthetic G4 DNA is consistent with the possibility that G4 DNA is the target for MutS α binding and synapsis within the G loops but does not eliminate the possibility that other structures are bound by MutS α . The synapsed structures imaged by electron microscopy may correspond to the higher order complexes evident in gel mobility shifts (Figures 2 and S1).

The plasmids pRX15F3 (S μ) and pPH600 (S γ 3) differ in length by 0.5 kb, allowing them to be distinguished in electron micrographic images. When equal amounts of these two plasmids were transcribed, incubated with MutS α , linearized, and imaged, there were examples not only of S μ -S γ 3 synapsis (e.g., Figure 3C, bottom), but also of S μ -S μ and S γ 3-S γ 3 synapsis (e.g., Figure 3C, top). Intra-S region synapsis (S μ -S μ or S γ 3-S γ 3) would produce intra-S region deletions, which are commonly found at switch junctions. Synapsed S μ -S γ 3 regions (Figure 3C, bottom) are a predicted intermediate in switch recombination from μ to γ 3 (see Figure 1). We

conclude that MutS α can promote S region synapsis in vitro.

Model for MutS α Function in Recombination at the S Regions

We have shown that MSH2 is enriched at activated S regions in switching B cells and that MutS α can promote synapsis of transcriptionally activated switch regions in vitro. Based on our findings, we propose a model for one possible function of MutS α in class-switch recombination (Figure 4). Transcription of S regions causes formation of a stable RNA/DNA hybrid on the C-rich template strand and formation of G4 DNA interspersed with single stranded regions on the G-rich strand and allows AID to deaminate C to U on the G-rich strand. Colocalization of transcribed sequences to transcription factories may contribute to juxtaposition of S regions targeted for recombination. MutS α binds the activated S regions, and MutS α molecules interact to promote S region synapsis.

Our results identify two potential targets for MutS α at the activated S regions: G4 DNA and U·G mismatches produced by AID deamination. Genetic analysis suggests that both these targets may be used in activated B cells. Switch recombination is absolutely dependent upon *Msh2* in a strain of mice lacking a highly repetitive region of S μ consisting of tandem reiterations of GAGTC, a hotspot for AID deamination [18]. This deletion leaves intact regions within S μ that are G rich and may therefore form G4 DNA, and recognition of G4 DNA by MutS α could provide an alternative route to class switch recom-

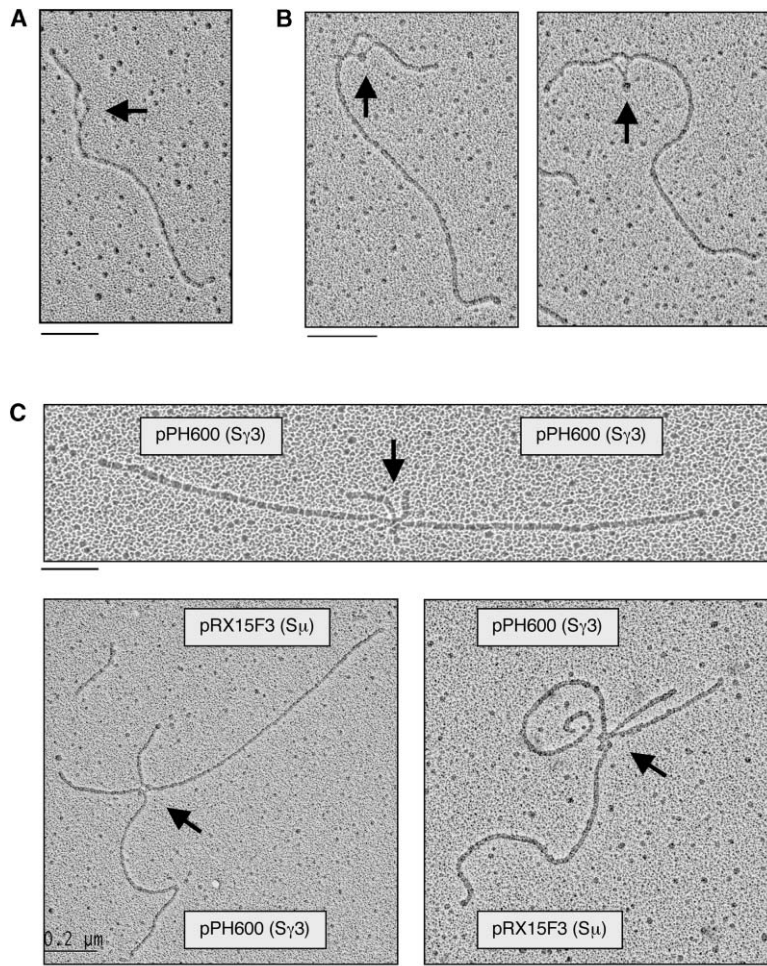

Figure 3. MutS α Binds to the Nontranscribed Strand of G Loops

(A) Example of G loop formed upon transcription, indicated by arrow. Bar, 200 nm.

(B) Representative EM image of MutS α bound to transcribed S γ 3 switch region in pPH600. Transcribed molecules were incubated with purified recombinant hMutS α and cross linked. MutS α bound to G loops is indicated by arrows. Bar, 200 nm.

(C) Representative EM images of MutS α -mediated synapsis between transcribed S μ and S γ 3 sequences. Transcribed plasmids were incubated with MutS α , cross linked, and linearized to distinguish the arms of plasmids containing S μ (pRX15F3) and S γ 3 (pPH600) sequences. Top, S γ 3-S γ 3 synapsis; bottom, S μ -S γ 3 synapsis. Bar, 200 nm.

bination involving the intact G-rich regions. Conversely, a low level of switch recombination can occur in *Ung*^{-/-} mice [19], but switching is completely abolished in *Ung*^{-/-} *Msh2*^{-/-} double mutants [20]. It is an intriguing possibility that in the *Ung*^{-/-} background, MutS α bound to U-G mismatches may recruit factors with downstream functions in recombination.

Supplemental Data

Supplemental Data include two figures, one table, and Supplemental Experimental Procedures and can be found with this article online at <http://www.current-biology.com/cgi/content/full/15/5/470/DC1/>.

Acknowledgments

We thank all members of the Maizels laboratory, especially Dr. Munehisa Yabuki, for valuable discussions. This research was supported by funding from the National Institutes of Health R01 GM39799 and R01 GM65988 (to N.M.) and F32 GM67482 (to E.D.L.) and from the University of Washington Medical Student Research Training Program (to R.J.S.). We also acknowledge the subsidized services of the National Cell Culture Center.

Received: September 27, 2004

Revised: December 27, 2004

Accepted: December 30, 2004

Published: March 8, 2005

References

1. Manis, J.P., Tian, M., and Alt, F.W. (2002). Mechanism and control of class-switch recombination. *Trends Immunol.* 23, 31–39.
2. Li, Z., Woo, C.J., Iglesias-Ussel, M.D., Ronai, D., and Scharff, M.D. (2004). The generation of antibody diversity through somatic hypermutation and class switch recombination. *Genes Dev.* 18, 1–11.
3. Ehrenstein, M.R., and Neuberger, M.S. (1999). Deficiency in *Msh2* affects the efficiency and local sequence specificity of immunoglobulin class-switch recombination: parallels with somatic hypermutation. *EMBO J.* 18, 3484–3490.
4. Schrader, C.E., Edelmann, W., Kucherlapati, R., and Stavnezer, J. (1999). Reduced isotype switching in splenic B cells from mice deficient in mismatch repair enzymes. *J. Exp. Med.* 190, 323–330.
5. Vora, K.A., Tumas-Brundage, K.M., Lentz, V.M., Cranston, A., Fishel, R., and Manser, T. (1999). Severe attenuation of the B cell immune response in *Msh2*-deficient mice. *J. Exp. Med.* 189, 471–481.
6. Li, Z., Scherer, S.J., Ronai, D., Iglesias-Ussel, M.D., Peled, J.U., Bardwell, P.D., Zhuang, M., Lee, K., Martin, A., Edelmann, W., et al. (2004). Examination of *Msh6*- and *Msh3*-deficient mice in class switching reveals overlapping and distinct roles of MutS homologues in antibody diversification. *J. Exp. Med.* 200, 47–59.
7. Martomo, S.A., Yang, W.W., and Gearhart, P.J. (2004). A role for *msh6* but not *msh3* in somatic hypermutation and class switch recombination. *J. Exp. Med.* 200, 61–68.
8. Wolner, B., van Komen, S., Sung, P., and Peterson, C.L. (2003). Recruitment of the recombinational repair machinery to a DNA double-strand break in yeast. *Mol. Cell* 12, 221–232.

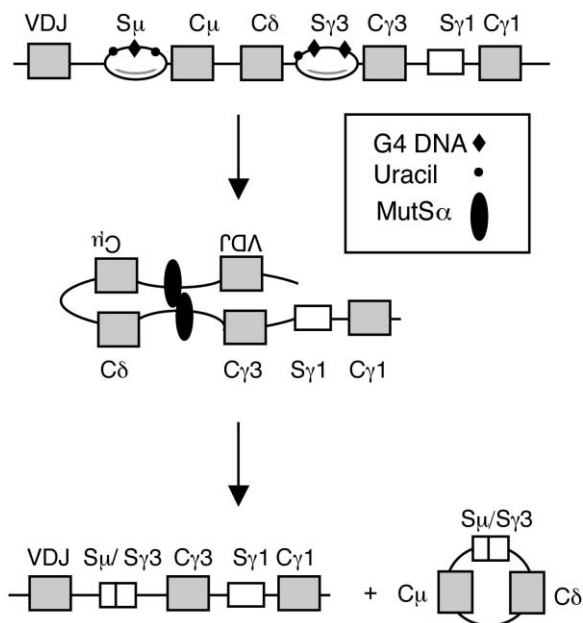

Figure 4. Model for MutS α Function in Class-Switch Recombination
Switch recombination is initiated by transcription, which produces a stable RNA:DNA hybrid (RNA, gray line); G4 DNA forms on the nontranscribed strand (diamonds) and within the transcribed region; AID deaminates cytidines to generate uracil (circles). MutS α (ovals) synapses the activated S regions. Resolution of DNA breaks generates a chromosomal S μ /S γ 3 junction and a switch circle.

9. Duquette, M.L., Handa, P., Vincent, J.A., Taylor, A.F., and Maizels, N. (2004). Intracellular transcription of G-rich DNAs induces formation of G-loops, novel structures containing G4 DNA. *Genes Dev.* 18, 1618–1629.
10. Neuberger, M.S., Harris, R.S., Di Noia, J., and Petersen-Mahrt, S.K. (2003). Immunity through DNA deamination. *Trends Biochem. Sci.* 28, 305–312.
11. Larson, E.D., and Maizels, N. (2004). Transcription-coupled mutagenesis by the DNA deaminase AID. *Genome Biol.* 5, 211.
12. Wang, H., Lawrence, C.W., Li, G.M., and Hays, J.B. (1999). Specific binding of human MSH2.MSH6 mismatch-repair protein heterodimers to DNA incorporating thymine- or uracil-containing UV light photoproducts opposite mismatched bases. *J. Biol. Chem.* 274, 16894–16900.
13. Biswas, I., Ban, C., Fleming, K.G., Qin, J., Lary, J.W., Yphantis, D.A., Yang, W., and Hsieh, P. (1999). Oligomerization of a MutS mismatch repair protein from *Thermus aquaticus*. *J. Biol. Chem.* 274, 23673–23678.
14. Bjornson, K.P., Blackwell, L.J., Sage, H., Baitinger, C., Allen, D., and Modrich, P. (2003). Assembly and molecular activities of the MutS tetramer. *J. Biol. Chem.* 278, 34667–34673.
15. Buermeyer, A.B., Deschenes, S.M., Baker, S.M., and Liskay, R.M. (1999). Mammalian DNA mismatch repair. *Annu. Rev. Genet.* 33, 533–564.
16. Martin, A., Li, Z., Lin, D.P., Bardwell, P.D., Iglesias-Ussel, M.D., Edelman, W., and Scharff, M.D. (2003). Msh2 ATPase activity is essential for somatic hypermutation at A-T basepairs and for efficient class switch recombination. *J. Exp. Med.* 198, 1171–1178.
17. Snowden, T., Acharya, S., Butz, C., Berardini, M., and Fishel, R. (2004). hMSH4-hMSH5 recognizes Holliday junctions and forms a meiosis-specific sliding clamp that embraces homologous chromosomes. *Mol. Cell* 15, 437–451.
18. Min, I.M., Schrader, C.E., Vardo, J., Luby, T.M., D'Avirro, N., Stavnezer, J., and Selsing, E. (2003). The Smu tandem repeat region is critical for Ig isotype switching in the absence of Msh2. *Immunity* 19, 515–524.

19. Rada, C., Williams, G.T., Nilsen, H., Barnes, D.E., Lindahl, T., and Neuberger, M.S. (2002). Immunoglobulin isotype switching is inhibited and somatic hypermutation perturbed in UNG-deficient mice. *Curr. Biol.* 12, 1748–1755.
20. Rada, C., Di Noia, J.M., and Neuberger, M.S. (2004). Mismatch recognition and uracil excision provide complementary paths to both Ig switching and the A/T-focused phase of somatic mutation. *Mol. Cell* 16, 163–171.