



Original Article

The collecting performance and interaction mechanism of sodium diisobutyl dithiophosphinate in sulfide minerals flotation



Hong Zhong*, Zhenrui Huang, Gang Zhao, Shuai Wang, Guangyi Liu, Zhanfang Cao

College of Chemistry and Chemical Engineering, Central South University, Changsha, China

ARTICLE INFO

Article history:

Received 20 June 2014

Accepted 4 December 2014

Available online 15 January 2015

Keywords:

Sodium diisobutyl

dithiophosphinate

Flotation

Interaction mechanism

Sulfide minerals

ABSTRACT

The interaction mechanism of sodium diisobutyl dithiophosphinate (DTPiNa) with chalcocopyrite, pyrite, galena and sphalerite was investigated by single mineral flotation experiment, adsorption measurement and FTIR spectrum analysis. Single mineral flotation experiments showed that sodium diisobutyl dithiophosphinate exhibited a strong ability to collect chalcocopyrite and galena. For chalcocopyrite and pyrite, the recovery of chalcocopyrite can reach 96.2% when the dosage is 12 mg/L and pH value is 8. In the same situation, the recovery of pyrite is as low as 13.5%. For galena and sphalerite, the recovery of galena reached 91.7% when the dosage was 50 mg/L at pH 11, and the recovery of sphalerite was only 16.9%. DTPiNa adsorbed on chalcocopyrite and galena surfaces are more than that on pyrite and sphalerite surfaces. The adsorption capacity of DTPiNa on the minerals surface is proportional to its dosage. The FTIR spectrum analysis results showed that the adsorption of DTPiNa on sulfide minerals surface is chemical and S atoms in $-P=S$ and $-P-S$ may have taken part in the reaction. The natural ores experiments also confirmed the excellent performance of sodium diisobutyl dithiophosphinate.

© 2014 Brazilian Metallurgical, Materials and Mining Association. Published by Elsevier Editora Ltda. All rights reserved.

1. Introduction

Chalcocopyrite is the major and most abundant commercial source of copper [1]. It is often accompanied with pyrite, which is the most widespread naturally occurring metal sulfides. The floatability of pyrite is quite similar to chalcocopyrite [2,3]. Pyrite in copper concentrates will not only lower their quality but also increase the economic and environmental costs in the subsequent smelting process [4]. The collecting ability of traditional sulfides collectors is very strong but their selectivity

is poor; thus, usually the ideal copper–sulfur separation could not be realized by these collectors. The copper released from chalcocopyrite will activate pyrite and increase the difficulty for the separation of chalcocopyrite and pyrite as well [5,6]. There are five common copper–sulfur separation processes, which are known as high pH process, inorganic inhibitors process, organic inhibitors process, electrochemical controlling process and cyanide process [7]. High pH value process is the most widely used process [8,9]. Even though this process could get perfect flotation and separation result, a large amount of lime must be consumed and the recovery and grade of copper

* Corresponding author.

E-mail: zhongh@mail.csu.edu.cn (H. Zhong).

<http://dx.doi.org/10.1016/j.jmrt.2014.12.003>

2238-7854/© 2014 Brazilian Metallurgical, Materials and Mining Association. Published by Elsevier Editora Ltda. All rights reserved.

concentrate will be lowered. Meanwhile, this method often brings difficulties of activating highly depressed pyrite, environmental pollution and high depression of noble metal such as Au, Ag and Mo. What is more, the floatability of chalcopyrite will be decreased because of the formation of hydrogen bond [10]. Consequently, it has aroused wide concern that the research of reagents can realize copper-sulfur separation at acidic and neutral pH [11,12], and a series of novel reagents were prepared, some of which appeared good performance in laboratorial and industrial practice [13-17].

Some researchers found an effective method to separate pyrite from chalcopyrite. In their research, BKY-1 was used as depressant in a wide range of pH. The following researches showed that the difference in interaction energy contributes to the selective depression. So xanthate could be used as the collector to float chalcopyrite selectively [18]. Peng used a specially designed mill, which could control the pH throughout the grinding processing to investigate the influence of grinding conditions on the flotation of chalcopyrite and copper-sulfur separation. It turned out that iron oxidation species from grinding media played a key role in depressing the floatability of chalcopyrite. The floatability of pyrite was significantly improved after grinding with mild steel medium. 30 wt% chromium medium will increase chalcopyrite floatability as well as decrease the pyrite floatability to strengthen the copper-sulfur separation effects [19]. Martin demonstrated that nitrogen conditioning could enhance the floatability of pyrite because of galvanic interaction. But this effect could be reversed by raising the pulp pH or introducing air. This phenomenon could be used to separate pyrite from some other sulfide ores with air [20]. The depressing ability of small polymers with various substituted functional groups such as carboxyl, sulfonate, hydroxyl and thiourea was researched. The results showed that hydroxy had the best depressing ability for pyrite depression and carboxyl had the best mineral selectivity. Their depressing ability in pyrite was strong because of the reaction with ferric ions/hydroxides, but they had no or little depression ability for sphalerite and copper activated sphalerite [21]. Mitchell proposed that heterocoagulation with different minerals was an effective way to selectively separate minerals involved. They discovered that pyrite had a positive zeta potential (ζ) up to its isoelectric point (IEP) at pH about 2.2, while chalcopyrite has a positive ζ up to its IEP at pH about 5.5 and the heterocoagulation of chalcopyrite with pyrite will happen between pH 2.2 and pH 5.5; thus it, is impossible to separate these two minerals. Flotation tests showed that at pH=10 thionocarbamate had good selective flotation of chalcopyrite from pyrite [22]. It was revealed that pulp oxidation potential (Eh) and zinc sulfate played an important role in copper-activated pyrite recovery. At pH 9.0 the maximal recovery of chalcopyrite and pyrite realized when the Eh was 275 and 135 mV, respectively. The maximal separation effect achieved at 275 mV and the addition of zinc sulfate could increase the mineral separation by selectively depressing pyrite flotation because large amount of ferric hydroxide groups formed on the pyrite surface, while at a lower Eh, such as 38 mV, the addition of zinc sulfate would improve flotation adversely because of the large increase of Eh. So zinc sulfate is not an effective mineral depressant at lower Eh values [23]. Chen investigated the combination of

sodium humate and lime in a low pH medium. By adding sodium humate to the pulp and adjusting the pH to 10-10.5, the recovery of Cu and combined Au, Ag and Mo in the copper concentrate was enhanced due to the reduced pH of the pulp. The following research showed that sodium humate was chemically adsorbed on the surface of pyrite and there was a strong hydrophilic interaction between sodium humate and the surface of pyrite [24].

For galena and sphalerite separation, there are two commonest processes, which are known as high pH process and inorganic inhibitors process. High pH process has significant disadvantages, such as decreasing the recovery of associated rare and precious metals and causing pipe blockage. Zinc sulfate is the commonly used inhibitor; its exorbitant price is the biggest drawback. Thus, the development of cheap inhibitors has aroused concerns. Rath investigated the influence of guar gum on the separation of galena and sphalerite by flotation. It was found out that at the pH 7.5 and 11.5 sphalerite and galena could get their maximum adsorption capacity, respectively. After the addition of guar gum, the recovery of galena was less than 20%, while the recovery of sphalerite did not have obvious change. Thus, it was possible to use guar gum as a depressant for galena [25].

DTPINa is the main efficient ingredient of Aerophine 3418A, and it is mainly recommended to float copper and lead sulfide ores compared with rare and noble metal [26]. Some researchers had investigated the interaction mechanism of DTPINa for its excellent flotation performance. Piantadosi used TOF-SIMS method to investigate the amount of DTPINa adsorbed onto the surface of galena and pyrite. The result showed that the affinity of DTPINa on galena was much higher than that onto pyrite and the presence of hydrophobic DTPINa and PbDTPINa were the key factors for flotation [27]. The inaction mechanism of DTPINa was investigated with activated and inactivated galena and pyrite. The research demonstrated that DTPINa was adsorbed onto galena and pyrite surface by a chemical absorption way and DTPINa displayed a strong affinity toward galena. The floatability of pyrite will be enhanced if it was activated by Pb-ions [28-30]. Güler investigated the influence of pH on the flotation for chalcopyrite through electrochemical control method. According to his research, slight oxidation was essential for a hydrophobic chalcopyrite surface; the increase of pH would result in excess oxidation and then decrease the floatability of chalcopyrite [31]. Liu used density functional theory (DFT) calculations to investigate the structure-reactivity relationship of diisobutyl dithiophosphate (DIBDTPA), diisobutyl dithiophosphinate (DIBDTPI), diisobutyl monothiophosphate (DIBMTPA) and diisobutyl monothiophosphinate (DIBMTPI) which are all used as sulfide minerals collectors. It showed that O atom(s) in the regents could significantly affect S atom(s), which made a critical difference in the flotation performance. Among the four collectors, DIBDTPI had the strongest reactive power to mineral surface and the ionized thiophosphorus collectors exhibited the strongest affinity to mineral surfaces in aqueous phase [32].

In this study, the collecting abilities and interaction mechanism of DTPINa with chalcopyrite, pyrite, galena and sphalerite were investigated through flotation experiments, adsorption capacity measurements and FTIR spectrum

Table 1 – Chemical composition analysis results of copper–sulfur natural ore.

| Elements | Cu (%) | Mo (%) | S (%) | Au (g/t) | Ag (g/t) | Fe (%) | Oxidation ratio (%) |
|-------------|--------|--------|-------|----------|----------|--------|---------------------|
| Composition | 0.413 | 0.0032 | 1.21 | 0.286 | 0.95 | 4.07 | 13.26 |

Table 2 – Copper phase analysis in copper–sulfur natural ore.

| Phase | Copper sulfide | Copper oxide | Total copper |
|------------------|----------------|--------------|--------------|
| Content (%) | 0.360 | 0.055 | 0.415 |
| Distribution (%) | 86.75 | 13.25 | 100.00 |

Table 3 – Chemical composition analysis results of lead–zinc natural ore.

| Elements | Pb (%) | Zn (%) | Ag (g/t) | S (%) |
|-------------|--------|--------|----------|-------|
| Composition | 8.85 | 13.12 | 113.2 | 10.87 |

analysis. It was considered that DTPINa has a stronger collecting ability and better selectivity, compared with traditional sulfide collectors. Therefore, copper–sulfur and lead–zinc separation could be realized at neutral or weak alkaline pulp.

2. Experimental

2.1. Reagents and minerals

Hand-picked chalcopyrite and pyrite were obtained from Tonglushan Copper Mine of Hubei Province and Yunfu Mine of Guangdong Province, China, respectively. Galena and sphalerite ores were obtained from Huangshaping Lead–zinc Mine of Hunan Province. Each kind of pure mineral was porcelain ground to a diameter between 0.032 and 0.074 mm. After rinsing with de-aerated water, the minerals were dried in vacuum drying oven for pure mineral flotation experiments. Chemical analysis of the four mineral samples indicated that their purities were 90.31% (chalcopyrite), 94.89% (pyrite), 93.34% (galena) and 94.56% (sphalerite), respectively.

The copper–sulfur natural ore samples were obtained from Sizhou Mine from Jiangxi Province (China), and the chemical composition analysis results are listed in Table 1 and the results of copper phase analysis are listed in Table 2. The lead–zinc natural ore samples were obtained from Guangxi province (China). The chemical composition analysis results are listed in Table 3 and the X-fluorescence spectrometry analysis is listed in Table 4. The purity of collector sodium-diisobutyl dithiophosphate (DTPINa) was as high as 99.77%, which was qualified for the following tests [29]. Butyl xanthate ethylthiocarbamate (Z-200), Ammonium dibutyl dithiophosphate and Sodium diethyldithiocarbamate were obtained from Zhuzhou Flotation Reagents Company. Methyl isobutyl carbinol (MIBC) was chosen as frother. Solutions of HCl and NaOH were used to adjust the pH of the pulp. Calcium oxide, cupric chloride dehydrates, ferrous chloride, lead chloride and zinc chloride reagents were used in the experiments. All the reagents, except collectors and frother, were analytical grade products and distilled water was used in all monomineral tests.

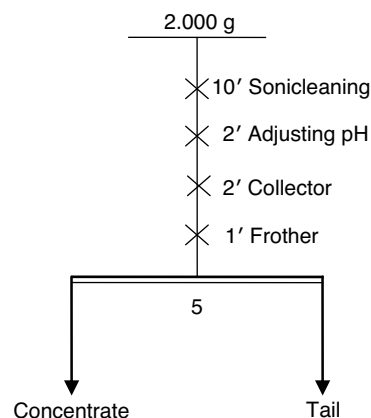
**Fig. 1 – Pure minerals flotation process.**

2.2. Flotation tests

Flotation tests were carried out with a XFG5-35 flotation machine with 40 mL effective cell volume and the impeller speed fixed at 1650 r/min. 2.0 g pure mineral was put into a 100.0 mL breaker with 40.0 mL distilled water to clean the surface for 10 min to wipe off the attached oxide by using ultrasonic cleaner. The treated mineral was washed with distilled water for three times and then transferred into the flotation cell. The pulp pH was adjusted with HCl or NaOH aqueous solution and then agitated for 2 min. After adding the desired amount of reagents, the suspension was agitated for 2 min, and the frother was last added before flotation. The flotation process was conducted for 5 min. The products and tails were weighed separately after filtration and dried and the recovery was calculated.

The specific flotation process was shown in Fig. 1 and the recovery was calculated according to the following equation:

$$R = \frac{m_1}{m_1 + m_2} \times 100\%$$

where R represents the pure minerals' recovery; m_1 and m_2 are the weight of froth products and products in the cell, respectively.

2.3. Natural ore samples experiments

The copper–sulfur and lead–zinc ores were crushed to 2.0 mm before samples were ground to 65.0% passing 0.074 mm in a closed stainless steel XMQ-φ240 × 90 ball mill at a pulp density of 62.5% by weight. To depress the pyrite and sphalerite, 1200 g/t and 6000 g/t lime were put into the mill while grinding and the pulp pH will be adjusted to 8 and 11 respectively. During the flotation the milled ores were transferred into a 3.0 L XFG single-trough flotation cell. The reagents were added into the flotation cell in sequence of collector and frother with a containing time of 2 and 1 min. The time of rough

Table 4 – X- fluorescence spectrometry analysis of lead–zinc natural ore (%).

| | | | | | | | | | |
|-------------|-------|-------|-------|--------|-------|--------|--------|--------|--------|
| Elements | Pb | Zn | Ag | Cu | Fe | S | O | Zr | Cd |
| Composition | 9.198 | 12.76 | 0.009 | 0.0289 | 2.522 | 5.689 | 38 | 0.0073 | 0.0528 |
| Elements | Na | Mg | Al | Si | P | Cl | K | Sb | Ba |
| Composition | 0.682 | 0.933 | 5.42 | 26.72 | 0.037 | 0.021 | 1.81 | 0.002 | 0.677 |
| Elements | Ca | Ti | Cr | Mn | Ni | Rb | Sr | | |
| Composition | 2.07 | 0.176 | 0.022 | 0.167 | 0.004 | 0.0105 | 0.0172 | | |

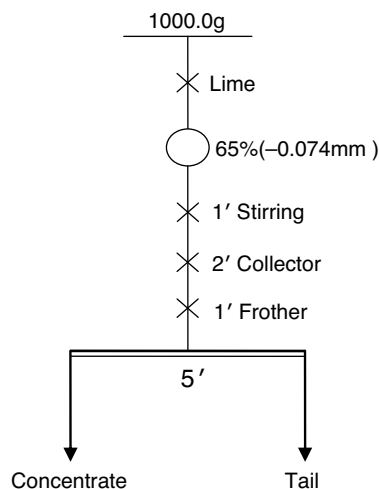
**Fig. 2 – Natural ore flotation process.**

flotation was controlled as 5 min. The distilled process is shown in Fig. 2. The rougher concentrates and tailings were filtered, dried, weighed, sampled and assayed for copper and tap water used in the test.

2.4. Adsorption experiments

2000 g pure minerals were added into a ground Erlenmeyer with specific concentration and then diluted to 40.0 mL with distilled water. The solution pH was regulated before vibrating at room temperature for 120 min. The upper clear liquid was centrifuged and then transferred into a 100.0 mL volumetric flask. The supernatant was analyzed by Total Organic Carbon Analyser (TOC-VCPH) to calculate the adsorption capacity.

2.5. FTIR-spectrum measurements

The DTPiNa solution was slowly added into metal ions (Cu^{2+} , Fe^{2+} , Pb^{2+} and Zn^{2+}) solutions of 10^{-2} mol/L in weak acid medium until no more precipitate was generated to prepare metal-collector complexes. The compounds were washed by distilled water for three times to wipe off redundant collector and metal ions attached on the compounds surface and dried at room temperature in a vacuum drying oven for 48 h. The IR spectra of metal-collector complexes were obtained by the using of a FTIR Avatar model 360 from Nicolet DIR Nicolet accessory (Nicolet spectrometer, AVATAR360, USA), and the dry KBr particles were used as the background.

Diffuse reflectance infrared spectroscopy (DIR) was used to characterize the surface species on the mineral particles treated. Samples were ground to be less than $5\ \mu\text{m}$ and were prepared the same way used in micro-flotation tests. The spectrum was obtained with the same instrument and presented without any baseline correction.

3. Results and discussions

3.1. Pure mineral flotation tests

3.1.1. Flotation recovery of pure minerals as a function of pH values

High alkaline process is often applied for traditional collectors in copper–sulfur separation process, but it will decrease the recovery of associated rare and precious metals and cause environmental pollution as well. Thus, it is essential to investigate the influence of pH on the floatability. In this paper butyl xanthate, Z-200 and DTPiNa were used as collectors with the dosage of 10.0 mg/L. MIBC was used as frother (7.5 mg/L). The results are displayed in Fig. 3a and b.

As shown in Fig. 3a and b, along with the increase of pH, the floatability by the three collectors will decrease. For chalcopyrite, DTPiNa had very strong collecting ability, its recovery was higher than 90.0% at all pH values from 2 to 13 and the highest recovery reached 98.6%. In the same dosage, the recovery by Butyl xanthate and Z-200 was less; especially in high pH situation, their recovery would decrease sharply. The three collectors had a similar collecting ability in pyrite; in acid environment the recovery was relatively high. Among them DTPiNa was the most sensitive to pH, the recovery would decrease most quickly in alkaline environment. When the pH was higher than 8, the recovery would be less than 10.0%, and the difference of recovery between chalcopyrite and pyrite could reach 81.8%, it was ready to realize copper–sulfur separation. The results showed that in DTPiNa pH had a weak influence on the recovery of chalcopyrite, while pyrite was quite sensitive to pH and the recovery would be depressed to a very low level. DTPiNa could be used to separate copper–sulfur in weak alkaline environment.

The flotation recovery of galena or sphalerite as a function of pH values under 20.0 mg/L DTPiNa, ammonium dibutyl dithiophosphate and sodium diethyldithiocarbamate is shown in Fig. 3d and c, where it could be seen that using DTPiNa as collector galena exhibited the best collecting ability. And the recovery was higher than ammonium dibutyl dithiophosphate and sodium diethyldithiocarbamate over the

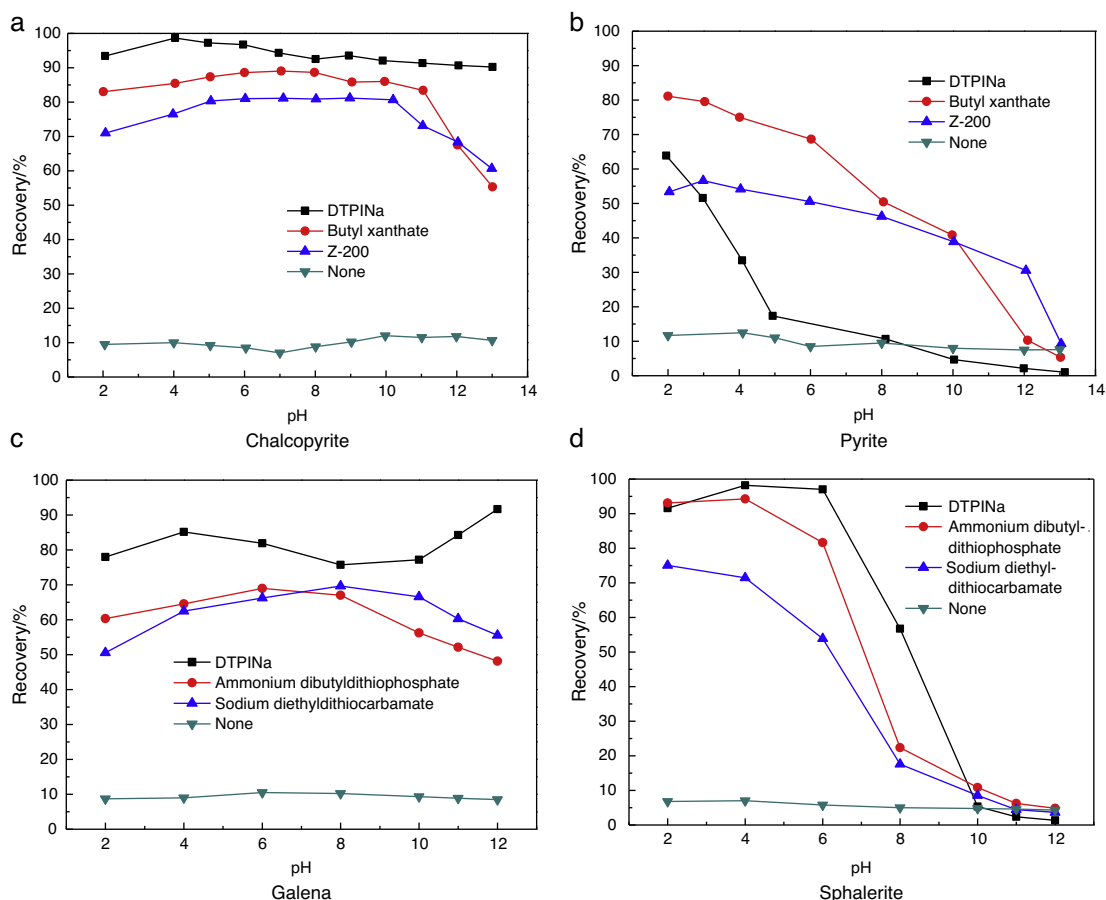

Fig. 3 – Flotation recoveries of pure minerals as a function of pH values.

whole pH range. In sphalerite, all the three collectors achieved excellent recoveries in acid environment and DTPiNa the highest recovery, while the recovery by DTPiNa was the lowest in alkaline pulp.

3.1.2. Effect of dosage on floatability of minerals

The pH was adjusted to 8 with sodium hydroxide solution to investigate the collecting ability of DTPiNa, butyl xanthate and Z-200 and the results were presented in Fig. 4a and b. From the figure, the recovery of chalcopyrite and pyrite was both increased with the increasing of collectors' dosage. For chalcopyrite, DTPiNa achieved a higher recovery than butyl xanthate and Z-200 in the same dosage and the recovery would reach the balance in a small dosage. The recovery of chalcopyrite could reach 96.2% in the dosage of 12.0 mg/L; meanwhile, the recovery of pyrite was as low as 13.7% and the difference reached up to 82.5%. For pyrite, in the same dosage, the recovery by DTPiNa was less than butyl xanthate and Z-200 and the recovery would reach the maximum value of 15.2%. The results suggested that DTPiNa had the strongest collecting ability and the best selectivity among the three collectors, and copper-sulfur separation could be realized in weak alkaline environment.

The effect of dosage on galena and sphalerite flotation recoveries of the three collectors is shown in Fig. 4c and d. In galena flotation the pulp pH of DTPiNa, ammonium

dibutyl dithiophosphate and sodium diethyldithiocarbamate was adjusted to 11. The results indicated that with increasing concentration of collectors, the flotation recoveries increased. When DTPiNa concentration was greater than 50.0 mg/L, the recovery reached its maximum (91.7%). In the same dosage, the recovery by DTPiNa was absolutely higher compared with ammonium dibutyl dithiophosphate and sodium diethyldithiocarbamate. In sphalerite, the pH was adjusted to 11. From the figure, we know that the recovery by DTPiNa was highest in sphalerite and the lead-zinc separation could be realized.

3.2. Natural ore flotation experiments

Butyl xanthate, Z-200 and DTPiNa were used as copper sulfide collectors. Ammonium dibutyl dithiophosphate, Sodium diethyldithiocarbamate and DTPiNa were used as lead sulfide collectors, respectively, to contrast their flotation ability (Tables 5 and 6). When Butyl xanthate, Z-200, ammonium dibutyl dithiophosphate and sodium diethyldithiocarbamate were used as collectors, MIBC was used as frother. The table indicated that DTPiNa exhibited stronger foaming ability and preferable collecting efficiency without extra frother.

The tables presented the grade and recovery of Cu and Pb by using different collectors. As it could be seen, the highest

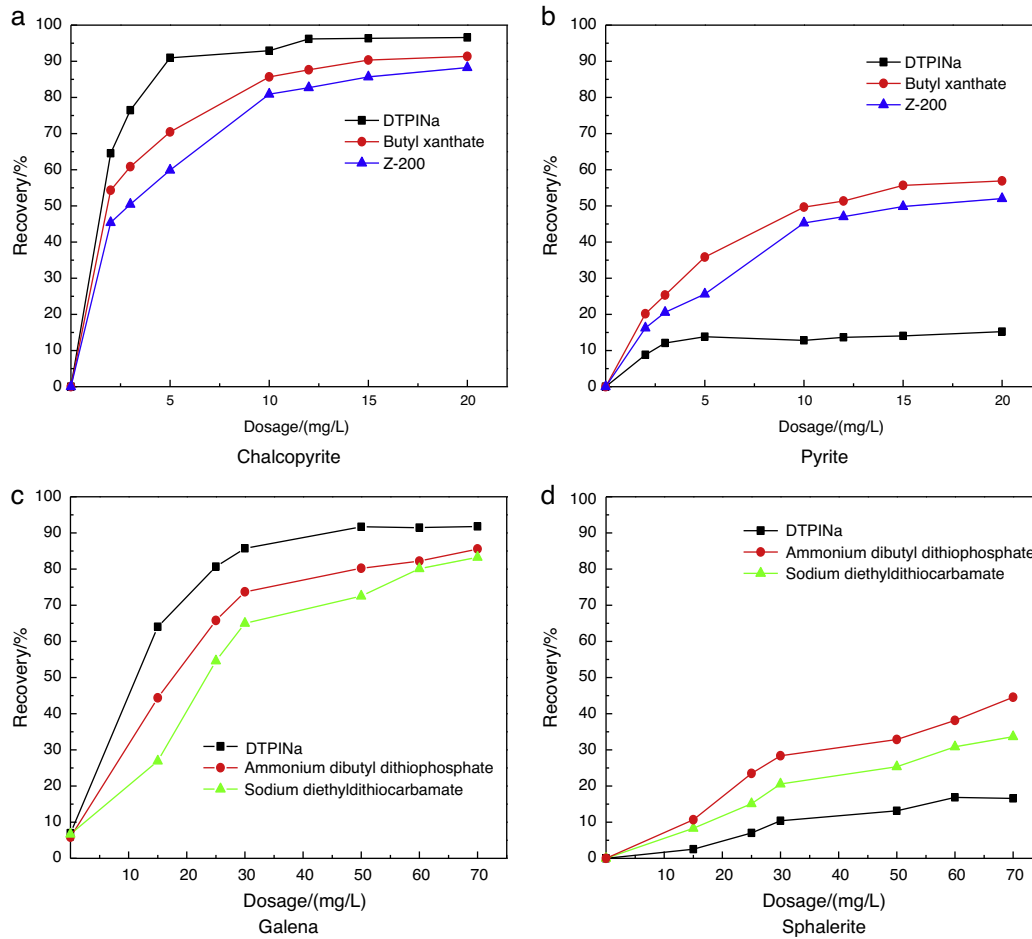

Fig. 4 – Effect of dosage on floatability of minerals.

Table 5 – Copper-sulfur ore flotation results.

| Reagents | Dosage (g/t) | Product | Yield (%) | Grade (%) | Recovery (%) |
|-----------------------|--------------|-------------|-----------|-----------|--------------|
| None | 0 | Concentrate | 1.20 | 3.56 | 10.56 |
| | | Tail | 98.8 | 0.37 | 89.44 |
| | | Raw ore | 100.00 | 0.41 | 100.00 |
| Butyl xanthate + MIBC | 50 + 32 | Concentrate | 4.76 | 7.27 | 84.49 |
| | | Tail | 95.24 | 0.067 | 15.51 |
| | | Raw ore | 100.00 | 0.41 | 100.00 |
| Z-200 + MIBC | 50 + 32 | Concentrate | 4.44 | 4.65 | 82.84 |
| | | Tail | 95.56 | 0.074 | 17.16 |
| | | Raw ore | 100.00 | 0.41 | 100.00 |
| DTPiNa | 40 | Concentrate | 5.92 | 6.33 | 91.35 |
| | | Tail | 94.08 | 0.038 | 8.65 |
| | | Raw ore | 100.00 | 0.41 | 100.00 |
| DTPiNa | 30 | Concentrate | 4.53 | 8.02 | 88.61 |
| | | Tail | 95.47 | 0.049 | 11.39 |
| | | Raw ore | 100.00 | 0.41 | 100.00 |

Table 6 – Lead-zinc ore flotation results.

| Reagents | Dosage (g/t) | Product | Yield (%) | Grade (%) | Recovery (%) |
|---|--------------|-------------|-----------|-----------|--------------|
| None | 0 | Concentrate | 2.57 | 30.27 | 8.45 |
| | | Tail | 97.43 | 8.64 | 91.55 |
| | | Raw ore | 100.00 | 9.19 | 100.00 |
| Ammonium dibutyl dithiophosphate + MIBC | 30 + 24 | Concentrate | 13.25 | 62.20 | 89.68 |
| | | Tail | 86.75 | 1.09 | 10.32 |
| | | Raw ore | 100.00 | 9.19 | 100.00 |
| Sodium diethyldithiocarbamate + MIBC | 30 + 24 | Concentrate | 12.15 | 66.42 | 87.81 |
| | | Tail | 87.85 | 1.27 | 12.19 |
| | | Raw ore | 100.00 | 9.19 | 100.00 |
| DTPiNa | 30 | Concentrate | 12.82 | 67.89 | 94.71 |
| | | Tail | 87.18 | 0.56 | 5.29 |
| | | Raw ore | 100.00 | 9.19 | 100.00 |
| DTPiNa | 24 | Concentrate | 11.88 | 71.01 | 91.80 |
| | | Tail | 88.12 | 0.86 | 8.20 |
| | | Raw ore | 100.00 | 9.19 | 100.00 |

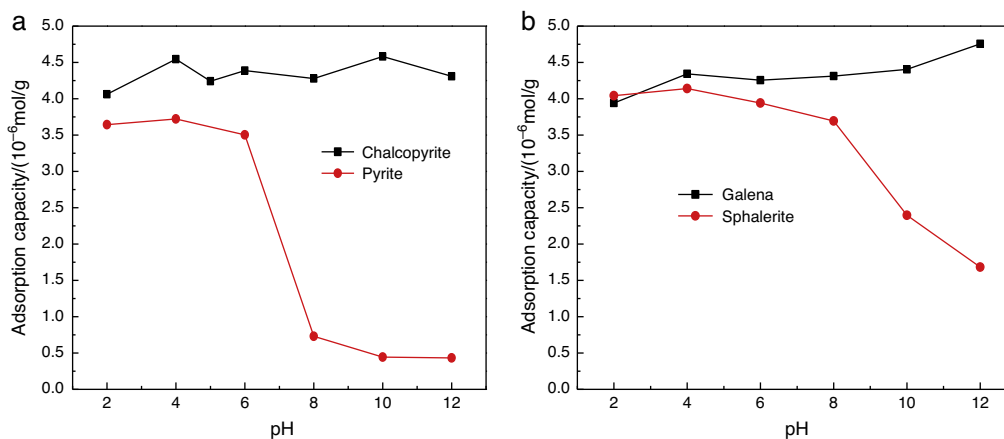

Fig. 5 – The influence of pH on adsorption capacity.

Cu and Pb grade and recovery were achieved by using the collector DTPiNa in a less dosage of collector without the using of frother. The tests indicated that DTPiNa had the strongest flotation ability and the best selectivity in copper sulfides and lead sulfides compared with the common collectors.

3.3. The interaction mechanism of minerals and DTPiNa

3.3.1. Adsorption analysis

The dosage of collector DTPiNa was fixed in 2.62×10^{-4} mol/L to investigate the influence of pH on the adsorbing capacity on

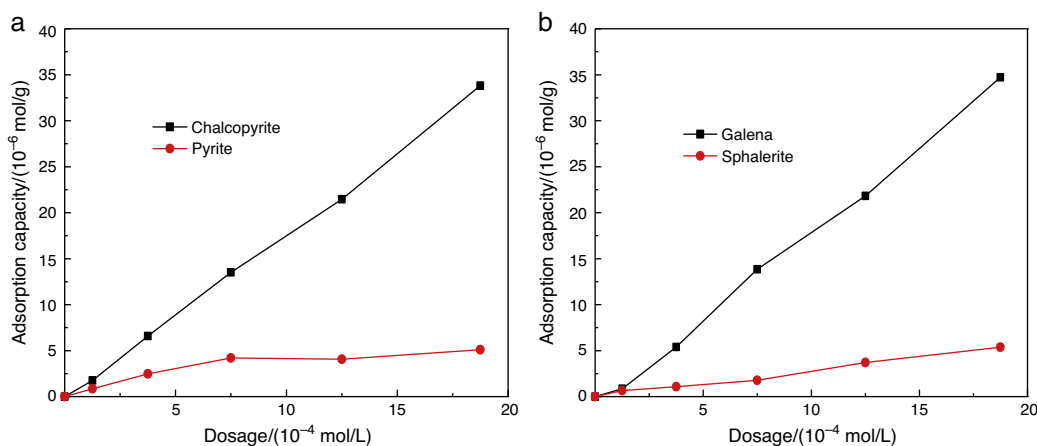

Fig. 6 – The influence of dosage on adsorption capacity.

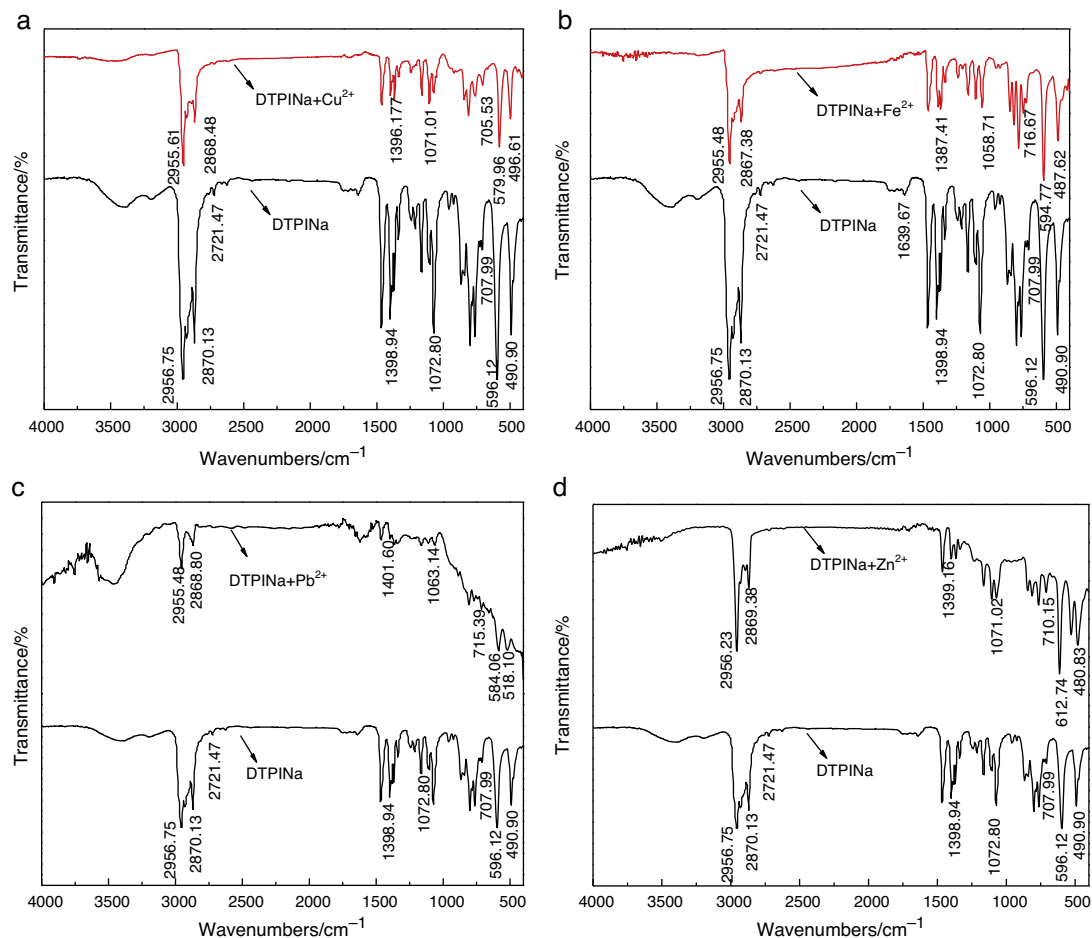

Fig. 7 – The spectrum of DTPiNa and metal-collector compounds.

the surface of minerals, and the results were shown in Fig. 5. Fig. 5a showed that the collector adsorbed on the chalcopyrite surface was enormous compared with that on pyrite. What is more, the adsorption capacity of chalcopyrite almost had nothing to do with the pH of pulp. In acid environment, the collector adsorbed on the pyrite surface was not much lesser than that on chalcopyrite surface; however, in alkaline environment the collector adsorbed on the pyrite surface would decrease rapidly. When the pH value was higher than 8 the pyrite adsorption capacity was down to 0.5×10^{-6} mol/g, while in the same situation, the chalcopyrite adsorption capacity was higher than 4.0×10^{-6} mol/g. The experiment indicated that DTPiNa was apt to adsorb on the chalcopyrite surface and pulp pH value had an obvious influence on pyrite adsorption capacity; in alkaline environment, the adsorption capacity difference between chalcopyrite and pyrite was tremendous. For galena and sphalerite, in acid pulp the adsorption capacity is similar, while in alkaline pulp the difference will become bigger and bigger. It suggested that in alkaline pulp DTPiNa preferred to react with galena.

The relationship between adsorption capacity and collector's concentration in chalcopyrite and pyrite was researched at the pulp pH 8. The results were displayed in Fig. 6a. It was discovered from the figure that with the enlargement of collector's concentration the collector adsorbed on

both minerals' surfaces would increase correspondingly. The adsorption capacity on chalcopyrite surface was throughout larger than that on pyrite surface and this tendency will become larger and larger due to the increasing of collector concentration. This test indicated that in weak alkaline situation collector was easier to adsorb on chalcopyrite surface, and the collector adsorbed on pyrite surface was quite small. Adsorption capacity test was in accordance with flotation test.

At pH 11, the adsorption of DTPiNa on galena and sphalerite surfaces as a function of its initial concentration is shown in Fig. 6b. The adsorption amounts of DTPiNa on these two minerals increased with the increase of DTPiNa concentration. The adsorbability of the two minerals in DTPiNa was followed in the order: galena > sphalerite. The adsorption results were consistent with the flotation results mentioned above.

3.3.2. Infrared spectrum analysis

The infrared spectrums of DTPiNa, DTPiNa+Cu²⁺, DTPiNa+Fe²⁺, DTPiNa+Pb²⁺, DTPiNa+Zn²⁺, chalcopyrite, pyrite, galena, sphalerite, DTPiNa +chalcopyrite, DTPiNa +pyrite, DTPiNa+galena, and DTPiNa+sphalerite are presented in Figs. 7 and 8. As was observed from Fig. 7, the peaks identified on DTPiNa sample show that the -CH₃ and -CH₂- stretching vibration peak was located at 2956.75 and

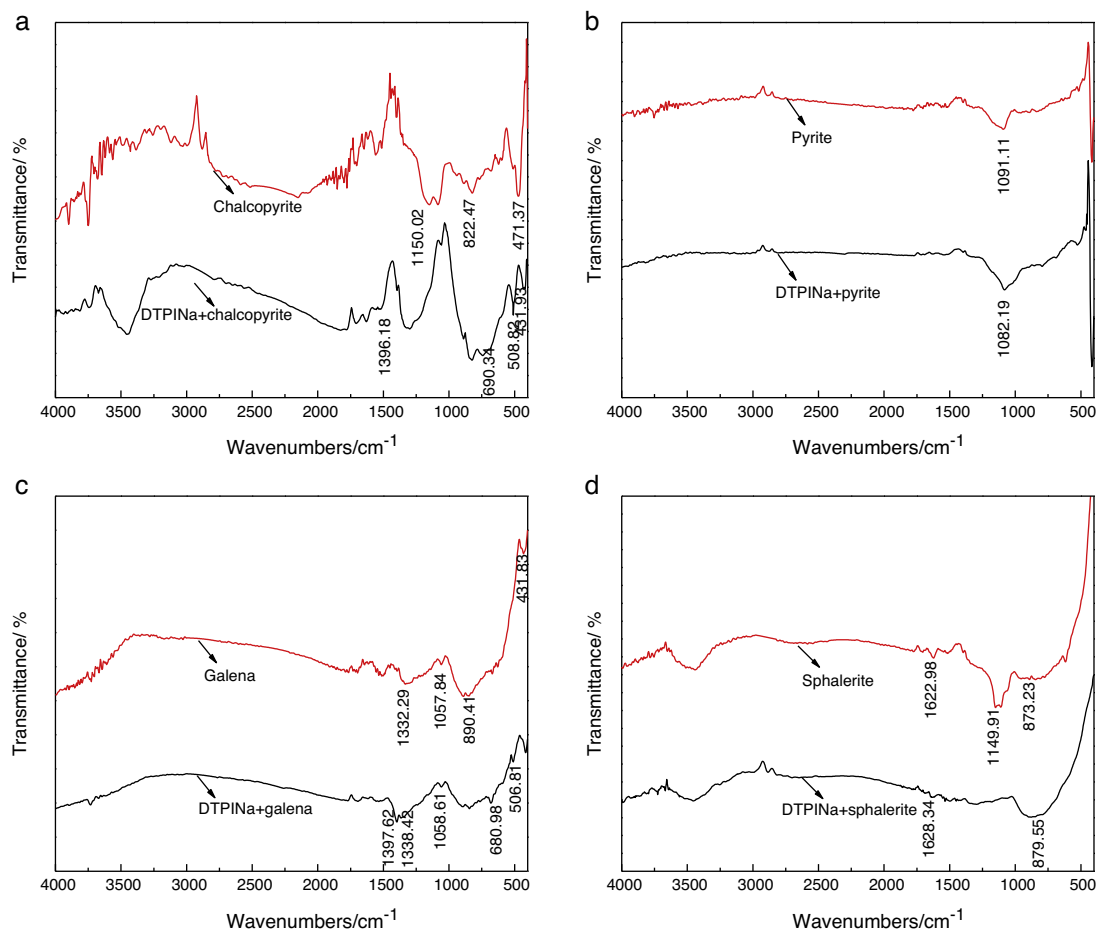

Fig. 8 – Infrared spectra of pure minerals and pure minerals interaction with DTPiNa.

2870.13 cm^{-1} ; 2721.47 cm^{-1} comes from $-\text{SNa}$ stretching vibration; the $-\text{C}(\text{CH}_3)_2$ stretching vibration was corresponding to 1398.94 cm^{-1} ; peak in 707.99, 596.12, and 490.90 cm^{-1} belonged to $\text{P}-\text{C}$ stretching vibration, $\text{P}=\text{S}$ stretching vibration and $\text{P}-\text{SNa}$ stretching vibration, respectively.

The infrared spectrums of synthesized metal-collector compounds are presented in Fig. 7. The figure showed that the spectra of the metal-collector compounds were similar to that of DTPiNa except the following small changes. After reacting with Cu^{2+} , Fe^{2+} , Pb^{2+} and Zn^{2+} the characterized peak of $-\text{SNa}$ in DTPiNa at around 2721 cm^{-1} was almost lost, it revealed that $-\text{SNa}$ may take part in the reaction with these ions. The stretching vibration peak of $-\text{CH}_3$, $-\text{CH}_2-$ at around 2956 cm^{-1} had faint transformation. The bending vibration of $-\text{C}(\text{CH}_3)_2$ at 1398 cm^{-1} had shifted to 1396, 1387, 1401 and 1399 cm^{-1} respectively. The stretching vibration peak of $-\text{P}-\text{C}$ at 708 cm^{-1} had offset to 705, 716, 715 and 710 cm^{-1} separately. The strong peak at 596 cm^{-1} in the DTPiNa spectrum due to the $\text{P}=\text{S}$ vibration was shifted to 579, 594, 584 and 612 cm^{-1} . The stretching vibration peak of $-\text{P}-\text{S}-$ at 491 cm^{-1} had offset to 496, 487, 518 and 480 cm^{-1} . All the changes suggested that the S atoms in $-\text{P}=\text{S}$ and $-\text{SNa}$ may have taken part in the reaction with these ions.

The diffuse reflectance infrared spectra for the four minerals before and after adsorption of DTPiNa are recorded

in Fig. 8. After interaction with DTPiNa the characteristic peaks for pure chalcopyrite become weak and the characteristic peak (1396.18 cm^{-1}) of DTPiNa appears. It also could be obviously seen that the $-\text{P}-\text{C}$ stretching vibration peak shifted from 707.99 to 690.34 cm^{-1} and $-\text{P}-\text{S}$ stretching vibration peak shifted from 490.90 to 508.82 cm^{-1} . All these indicate that chemical adsorption had occurred when DTPiNa was absorbed onto chalcopyrite surface and hydrophobic $\text{Cu}(\text{DTPI})_2$ and $(\text{DTPI})_2$ may be generated [33,34]. After interaction with DTPiNa, the $-\text{C}(\text{CH}_3)_2$, $\text{P}-\text{C}$ and $-\text{P}-\text{S}$ vibrations at around 1398, 681 and 507 cm^{-1} , respectively, appeared on galena surface, which inferred that DTPiNa might initially adsorb on chalcopyrite and galena surfaces by chemisorptions. While for pyrite and sphalerite, Fig. 8 demonstrated that no new characteristic adsorption peaks appeared on their surfaces, which may be caused by the equipment limitations or the weak characterized peak of DTPiNa.

4. Conclusions

Pure mineral tests made it clear that DTPiNa had very strong collecting ability to chalcopyrite that was little affected by the pulp pH. DTPiNa had better selectivity to chalcopyrite and the recovery of pyrite would drop to be less than 5.0% when the

pulp pH was higher than 8 and the copper-sulfur separation could be realized in this situation.

For galena and sphalerite pure minerals, high floatability was achieved by DTPiNa as well. DTPiNa exhibited stronger collecting ability and better selectivity than ammonium dibutyl dithiophosphate and sodium diethyldithiocarbamate. At pH value 11 the lead-zinc separation could be realized.

Adsorption test showed that DTPiNa preferred to be adsorbed on the chalcopyrite and galena surfaces and was far more than that absorbed onto pyrite and sphalerite surfaces, especially in alkaline pulp. The FTIR test revealed that S atoms in $-P=S$ and $-P-S$ may have taken part in the reaction with Cu^{2+} , Fe^{2+} , Pb^{2+} and Zn^{2+} to produce metal-collector complexes. After interacting with DTPiNa, the infrared spectrum of chalcopyrite and galena changed greatly and the characteristic adsorption peak of DTPiNa was raised, while the infrared spectrum of pyrite and sphalerite had no obvious change compared with the treated pyrite and sphalerite. The adsorption test and FTIR spectrum analysis indicated that it was chemical absorption when DTPiNa was adsorbed on the mineral surfaces.

The natural ore mineral experiments demonstrated that DTPiNa had a stronger collecting ability and better selectivity for copper sulfide ores and lead-zinc sulfide ores than common collectors.

Conflicts of interest

The authors declare no conflicts of interest.

Acknowledgments

The authors would like to thank the National High Technology Research and Development Program of China (863 program) (2013AA064101 and 2013AA064102) for the financial supports of this research.

REFERENCES

- [1] Acres RG, Harmer SL, Beattie DA. Synchrotron XPS, NEXAFS and ToF-SIMS studies of solution exposed chalcopyrite and heterogeneous chalcopyrite with pyrite. *Miner Eng* 2010;23:928-36.
- [2] Chandraprabha MN, Natarajan KA, Modak JM. Selective separation of pyrite and chalcopyrite by biomodulation. *Colloids Surf B: Biointerfaces* 2004;37:93-100.
- [3] Heyes GW, Trahar WJ. The natural floatability of chalcopyrite. *Int J Miner Process* 1977;4:317-44.
- [4] Gu G, Sun X, Li J, Hu Y. Influences of collector DLZ on chalcopyrite and pyrite flotation. *J Cent South Univ Technol* 2010;17:285-8.
- [5] Finkelstein NP. The activation of sulphide minerals for flotation: a review. *Int J Miner Process* 1997;52:81-120.
- [6] Zhang Q, Xu Z, Bozkurt V, Finch JA. Pyrite flotation in the presence of metal ions and sphalerite. *Int J Miner Process* 1997;52:187-201.
- [7] Li C, Sun Y. The research progress of copper sulfide flotation separation. *Met Ore Dress Abroad* 2000;08:2-7.
- [8] López VA, Celedón CT, Song S, Robledo CA, Laskowskib JS. Dextrin as a non-toxic depressant for pyrite in flotation with xanthates as collector. *Miner Eng* 2004;17:1001-6.
- [9] Smith RW. Liquid and solid wastes from mineral processing plants. *Miner Process Extr Metall Rev* 1996;16:1-22.
- [10] Trahar WJ. The influence of pulp potential in sulphide flotation. *Princ Miner Flotat* 1984;40:117-35.
- [11] Li Z, Liu J, Wang Z, Zhu R. Domestic research status on flotation separation of Cu-S. *Mod Min* 2010;3:12-5.
- [12] Shao F, Wang F. Computer aided molecular design for the high selectivity collectors of chalcopyrite and pyrite. *Nonferr Met* 2010;2:41-4.
- [13] Ou L, Feng Q, Shen G. Reacting mechanism of new collector CSU-A with chalcopyrite. *J Cent South Univ Technol* 2003;34:603-5.
- [14] Liu G, Zhong H, Dai T. The separation of Cu/Fe sulfide minerals at slightly alkaline conditions by using ethoxycarbonyl thionocarbamates as collectors: theory and practice. *Miner Eng* 2006;19:1380-4.
- [15] Sharma PK, Hanumantha RK, Forssberg E, Natarajan KA. Surface chemical characterisation of *Paenibacillus polymyxa* before and after adaptation to sulfide minerals. *Int J Miner Process* 2001;62:3-25.
- [16] Shen W, Fornasiero D, Ralston J. Effect of collectors: conditioning pH and gases in the separation of sphalerite from pyrite. *Miner Eng* 1998;11:145-58.
- [17] Reyes BL, Herrera UR, Sáez NC, Alfonso FO, Godoy FA, Ginocchio R. Rougher flotation of copper sulphide ore using biosolids and humic acids. *Miner Eng* 2011;24:1603-8.
- [18] Tao K, Wei M. Mechanism research on a new type of organic depressant BKY-1 for separation of chalcopyrite and pyrite. *Nonferr Met* 2013;5:73-7.
- [19] Peng Y, Grano S, Fornasiero D, Ralston J. Control of grinding conditions in the flotation of chalcopyrite and its separation from pyrite. *Int J Miner Process* 2003;69:87-100.
- [20] Martin CJ, Rao SR, Finch JA, Leroux M. Complex sulphide ore processing with pyrite flotation by nitrogen. *Int J Miner Process* 1989;26:95-110.
- [21] Boulton Adrian, Fornasiero Daniel, Ralston John. Selective depression of pyrite with polyacrylamide polymers. *Int J Miner Process* 2001;61:13-22.
- [22] Mitchell TK, Nguyen AV, Evans GM. Heterocoagulation of chalcopyrite and pyrite minerals in flotation separation. *Adv Colloid Interface Sci* 2005;114:227-37.
- [23] He S, Skinner William, Fornasiero Daniel. Effect of oxidation potential and zinc sulphate on the separation of chalcopyrite from pyrite. *Int J Miner Process* 2006;80:169-76.
- [24] Chen J, Li Y, Chen Y. Cu-S flotation separation via the combination of sodium humate and lime in a low pH medium. *Miner Eng* 2011;24:58-63.
- [25] Rath RK, Subramanian S. Effect of guar gum on selective separation of sphalerite from galena by flotation. *Trans Inst Min Metall C: Miner Process Extr Metall* 1999;108:C1-7.
- [26] Mingione P. Use of AEROPHINE® 3418A promoter for sulphide minerals flotation[C]. In: The 120th Annual Meeting of SME/AIME and 75th Annual Meeting of WAAIME, Feb. 25-28, Denver, Colorado, USA. 1991. p. 54.
- [27] Piantadosi C, Smart RSC. Statistical comparison of hydrophobic and hydrophilic species on galena and pyrite particles in flotation concentrates and tails from TOF-SIMS evidence. *Int J Miner Process* 2002;64:43-54.
- [28] Pecina ET, Uribe A, Nava F, Pérez GR. On the sodium-diisobutyl dithiophosphinate (Aerophine 3418A) interaction with activated and unactivated galena and pyrite. *Int J Miner Process* 2003;71:201-17.
- [29] Pecina ET, Uribe A, Finch JA, Nava F. Mechanism of di-isobutyl dithiophosphinate adsorption onto galena and pyrite. *Miner Eng* 2006;19:904-11.

-
- [30] Pecina ET, Uribe A, Nava F, Finch JA. The role of copper and lead in the activation of pyrite in xanthate and non-xanthate systems. *Miner Eng* 2006;19:172-9.
- [31] Güler Taki, Hiçyılmaz Cahit. Hydrophobicity of chalcopyrite with dithiophosphate and dithiophosphinate in electrochemically controlled condition. *Colloids Surf A: Physicochem Eng Asp* 2004;235:11-5.
- [32] Liu G, Xiao J, Zhou D, Zhong H, Phillip C, Xu Z. A DFT study on the structure-reactivity relationship of thiophosphorus acids as flotation collectors with sulfide minerals: implication of surface adsorption. *Colloids Surf A: Physicochem Eng Asp* 2013;434:243-52.
- [33] Güler T, Hiçyılmaz C, Gökağaç G, Ekmeçi E. Adsorption of dithiophosphate and dithiophosphinate on chalcopyrite. *Miner Eng* 2006;19:62-71.
- [34] Güler Taki. Investigation of the Adsorption of Dithiophosphate and Dithiophosphinate on Chalcopyrite as a Function of Pulp Potential and PH. Middle East Technical University, Department of Mining Engineering; 2002.