

Available online at www.sciencedirect.com**ScienceDirect**

Procedia Engineering 160 (2016) 207 – 213

**Procedia
Engineering**www.elsevier.com/locate/procedia

XVIII International Colloquium on Mechanical Fatigue of Metals (ICMFM XVIII)

Self-compacting concrete, protecting steel reinforcement under cyclic load: evaluation of fatigue crack behavior

Thomas Thienpont^{a,b}, Wouter De Corte^a, Stanislav Seitl^{b,c,*},^a*Ghent University, Department of Structural Engineering, Faculty of Engineering and Architecture, V. Vaerwyckweg 1, 9000 Ghent, Belgium*^b*Brno University of Technology, Faculty of Civil Engineering, Veveří 331/95, Brno 602 00, Czech Republic*^c*Institute of Physics of Materials, Academy of Sciences of the Czech Republic, Žitkova 22, 616 62 Brno, Czech Republic*

Abstract

The unique properties of self-compacting concrete of high workability without loss of stability and improved durability allow better protection of steel reinforcement in concrete structures. Recently, fatigue behavior has become more important for the design of constructions due to slimmer structures, which are more sensitive to fatigue loading. This article aims to evaluate the fatigue crack propagation rate in vibrated concrete and self-compacting concrete under different stress ratios using the Paris-Erdogan law, based on crack mouth opening displacement measurement from cyclic three-point bend tests on single edge notched beams.

© 2016 The Authors. Published by Elsevier Ltd. This is an open access article under the CC BY-NC-ND license

(<http://creativecommons.org/licenses/by-nc-nd/4.0/>).

Peer-review under responsibility of the University of Oviedo

Keywords: Steel Reinforcement; Fatigue Crack Behavior; Self-compacting Concrete; Three-point Bending Test; Paris' Law; Stress Ratio

1. Introduction

Worldwide, the market share of self-compacting concrete (SCC) is rapidly growing because of the economic opportunities and improvements of the quality of the concrete and the working environment [3]. Its unique properties of high workability without loss of stability have allowed for complex construction and rigorous construction schedules. For example, SCC was used in the construction of the anchorage blocks of the Akashi Kaikyō Bridge in

* Corresponding author. Tel.: +42-532-290-361.

E-mail address: seitl@ipm.cz

Japan, the suspension bridge with the largest main span in the world. The use of this new material shortened the anchorage construction period by 20%, from 2.5 to 2 years [13].

One of the original drivers in the development of SCC was increased durability of the finished product. The durability of concrete is governed by the permeability and uniformity of consolidation. SCC typically has a low water-cement ratio and high paste content. The high quality transition zone between the paste and aggregate also decreases permeability [17]. When it comes to the design of long lifetime structure, durability and especially permeability play an important role. A lower permeability decreases the chance of penetration of water and chemicals, which might otherwise lead to corrosion of the steel reinforcement. Low permeability thus increases the lifetime of the structure.

After two decades of research, the short term properties and behaviour of this new concrete type are thoroughly researched [10], while its long term fatigue behaviour is not yet fully understood. The availability of data from long term field performance is scarce because of limited use and relatively recent introduction [5]. However, a distinct fracture behaviour can be expected, since the strength of the cement paste and the location and size of the aggregates play an important role in the crack propagation phenomenon [8]. In order to reliably predict the behaviour of SCC in applications which involve millions of load cycles (e.g. bridges, beam cranes, offshore constructions), more research is required. Fatigue behaviour in concrete is a complex process, and even though a tremendous effort has been made by the international scientific community, no universally accepted strategy suitable to efficiently perform the fatigue assessment of concrete has been agreed yet [18].

This article aims to evaluate and compare the fatigue crack propagation rate in SCC and traditional vibrated concrete (VC) by the well-established Paris-Erdogan law [15]. Therefore, three types of concrete were assessed: a traditional VC, a SCC with comparable strength (SCC1) and a SCC with a comparable water/cement ratio (SCC2). Herein, VC is used for comparison, since its fracture properties are well known [2]. The comparison is based on data from three-point bend tests (3PBT) specimens, loaded under four different stress ratios, and was obtained from the research of Korte et al [18,19]. In this research, the data was obtained from static tests (strength of material, fracture toughness, Young's modulus and Poisson ratio) and by performing cyclic tests on notched specimens, while measuring the crack mouth opening displacement (CMOD) for each load cycle. For this study, finite element analysis software ANSYS [1] was then used to correlate the measured CMOD data with the Paris-Erdogan law for crack propagation. Herein, the crack propagation rate da/dN is plotted against the corresponding stress intensity range ΔK in a log-log graph. In a final step, the Paris-Erdogan law parameters C and m were obtained through linear curve fitting on the data points from the obtained graphs. The parameters C and m are then used to compare and evaluate the fatigue crack behaviour in SCC and VC.

2. Theoretical background

Fatigue may be defined as a process of progressive, permanent internal structural changes in a material subjected to repeated loading. In concrete, these changes are mainly associated with the progressive growth of internal microcracks, which results in a significant increase of irrecoverable damage. At the macro level, this will result in changes in the material's mechanical properties [14].

Three-point bend tests (3PBT) are often used to determine the fatigue fracture properties of structural materials such as cement based composites [16]. In the reference tests used in this research, the specimens were subjected to a sinusoidal load function (0.33 Hz) until failure, while measuring the CMOD at the crack mouth for each cycle, using a clip gauge. The 3PBT on single edge notched beams is a useful configuration for fracture toughness testing since it can be easily shaped and tested. For the test specimens, a value of $S/W=3$ was used in which S is the span between the supports, and W the depth of the specimen. Its geometry (Fig. 1) is included in all international standards for fracture toughness testing [6].

In order to evaluate fatigue behaviour of VC, the 3PBT results were correlated with the Paris-Erdogan law (eq. 1), which describes the relationship between the crack propagation rate da/dN and the stress intensity ratio ΔK [15]:

$$\frac{da}{dN} = C * (\Delta K)^m. \quad (1)$$

Herein, C and m depend on the material, the specimen geometry and the loading conditions. They are therefore different for each material and must be obtained experimentally. The formula in equation 2-1 is applicable to a wide range of materials and describes their crack propagation behaviour in a relatively correct way over a wide range of stress ratios. If the crack propagation law for a certain material is known, it is possible to calculate by integration the number of cycles required for the crack to grow from one length to another [7]. In this article, the Paris' law parameters C and m will be used to compare the data from the 3PBT's.

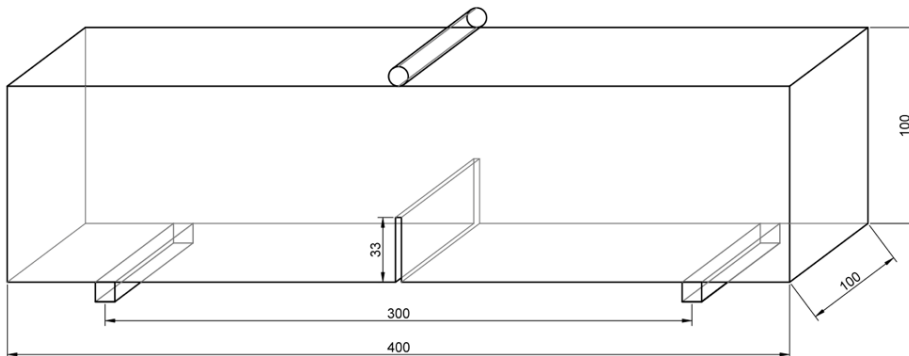

Fig. 1. Three-point bend test geometry (dimensions in mm)

3. Finite element analysis

3.1. Numerical model

The finite element analysis software ANSYS [1] was used to create and evaluate the numerical 3PBT model (Fig. 2). The model was built using macro's in the ANSYS Parametric Design Language (APDL). Only one half of the test piece is modelled, since its shape is symmetrical. All calculations were executed as a simplified 2D model, using 8-node isoparametric PLANE183 elements. From a comparative study, in which four different mesh sizes were evaluated, it was concluded that a 1 mm mesh size is dense enough to obtain accurate results. In order to accurately model the stresses near the crack tip, the ANSYS command KSCON is used. This creates a dense circular mesh around the crack tip which also allows for the calculation of the stress intensity factor, using the KCALC command. Since the differences in the results for the deflection and the stress fields for both 2D and a 3D models are very small [11,18], the use of a 2D model is preferred, since a simplified 2D model requires little computing power compared to complex 3D models.

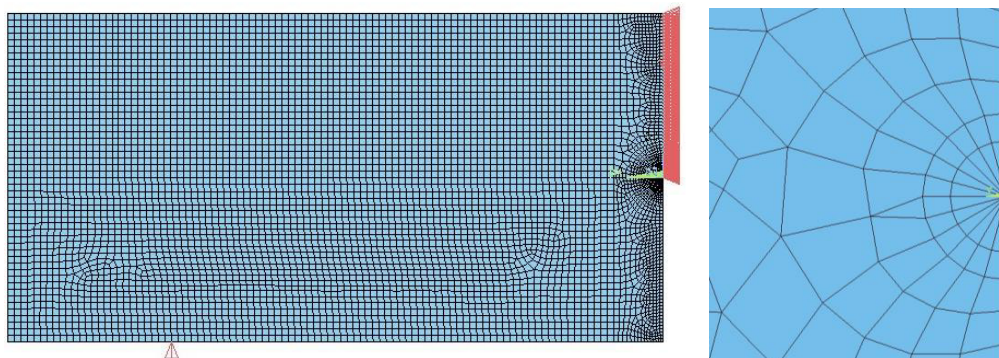

Fig. 2. (a) 3PBT numerical model in ANSYS; (b) detailed view of the mesh near the crack tip

For all concrete mixtures, cyclic tests under four stress ratios R were executed in the research of Korte et al. In these stress ratios, the lower load limit of was chosen to be 10% of the average ultimate load of the static tests. For the upper limit various percentages were selected: 70%, 75%, 80%, and 90% [18]. The stress ratio R is usually expressed as: $R = \sigma_{min}/\sigma_{max}$. Using this formula, the four stress ratios are: $R_{10-70} = 0.1429$, $R_{10-75} = 0.1333$, $R_{10-80} = 0.1250$ and $R_{10-90} = 0.1111$. In order to calculate the crack propagation rate and stress intensity ranges for all four ratios, the numerical model was loaded under 10%, 70%, 75%, 80% and 90% of the average ultimate load of the static tests. The material input parameters were taken from [18]-[21]: Young’s modulus $E_{VC} = 38.4$ GPa, $E_{SCC1} = 38.1$ GPa, $E_{SCC2} = 35.3$ GPa and Poisson ratio $\nu = 0.2$.

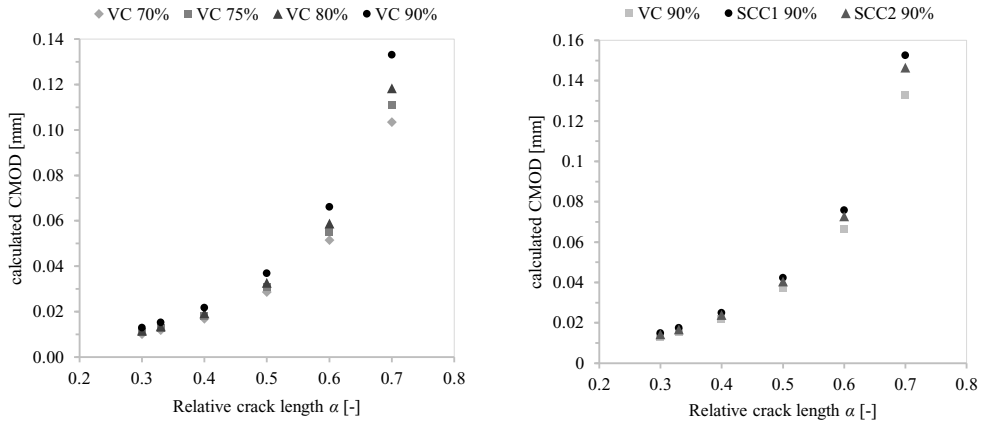

Fig. 3. (a) calculated CMOD for loads 70% ,75% ,80% and 90% on VC; (b) calculated CMOD for VC, SCC1 and SCC2 under 90% load

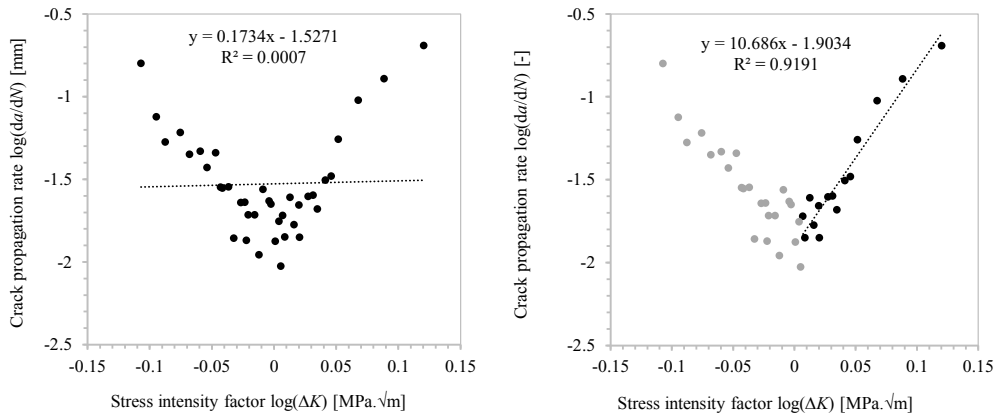

Fig. 4. (a) Paris-Erdogan data points on log-log graph (b) data points in acceleration phase, with linear fitting curve

3.2. Data evaluation

Neither the crack propagation rate da/dN nor the stress intensity range ΔK , used in the Paris-Erdogan law, can be directly measured during a cyclic 3PBT. They must therefore be obtained using a combination of finite element analysis and a number of calculation procedures. First, a mathematical relationship between the relative crack length $\alpha (= a/W)$, the dimensionless ratio between the crack length a and the height W , and the CMOD is calculated through inverse analysis. This was achieved by calculating the CMOD for fixed values of α , at intervals of 0.1. Fig. 3.a depicts the calculated CMOD values from the 3PBT on VC, under the load values, ranging from 70% to 90% of the ultimate

static load. Fig. 3.b on the other hand depicts the calculated CMOD values from the three tested concrete mixtures, under 90% of the ultimate static load.

The plotted fitting curves show that an exponential relationship between the CMOD and the relative crack length can be found. Exponential fitting curves were calculated for all stress ratios and all concrete mixtures. The inverse functions, which relate the relative crack length α to the CMOD where then used in further calculations. In a next step, the stress intensity range ΔK is computed for both geometries under the four stress ratios, using the built-in ANSYS command KCALC [1]. Similar to the CMOD calculations, an exponential relationship between ΔK and α can be found through curve fitting. The mathematical functions, which relate the relative crack length α to the stress intensity range ΔK where then used in further calculations.

Finally, the crack propagation rate da/dN is plotted against the stress intensity ratio ΔK . As shown in Fig. 4.a, the data points with an according smaller value of ΔK do not fit the linear relationship described by the Paris-Erdogan law. This is due to the fact that in concrete, two stages of crack growth can be observed: deceleration and acceleration [9]. Concrete fatigue fracture in the acceleration stage follows the Paris- Erdogan law [22],[23]. Therefore, in order to obtain a fitting curve with a reasonably high R^2 value, only the data points in the acceleration stage are used while the grey data points (Fig. 4.b) were ignored. This method was used to determine the linear fitting curves for all tested stress ratios.

4. Discussion of results

The fitting curves for VC and the two SCC type are given in Fig. 5a for the 10-70% and and for the 10-75% stress ratio in Fig. 5.b. For both the 10-80% and 10-90% stress ratio, no comparative graphs were made, since test data from VC and SCC1 for these stress ratios is not available, due to failure of the test specimens after very few load cycles. The Paris' law parameters m and C in eq. 1 from the 3PBT, which were obtained from the fitting curves of the $da/dN-\Delta K$ plots are given in Table 1. Depending on the total number of cycles and the quality of the curve fitting, two or three equations were obtained from each cyclic 3PBT. The parameters m and C are both the average values from the obtained fitting curves from each experiment. The last column shows the number of cycles N_{tot} from each test.

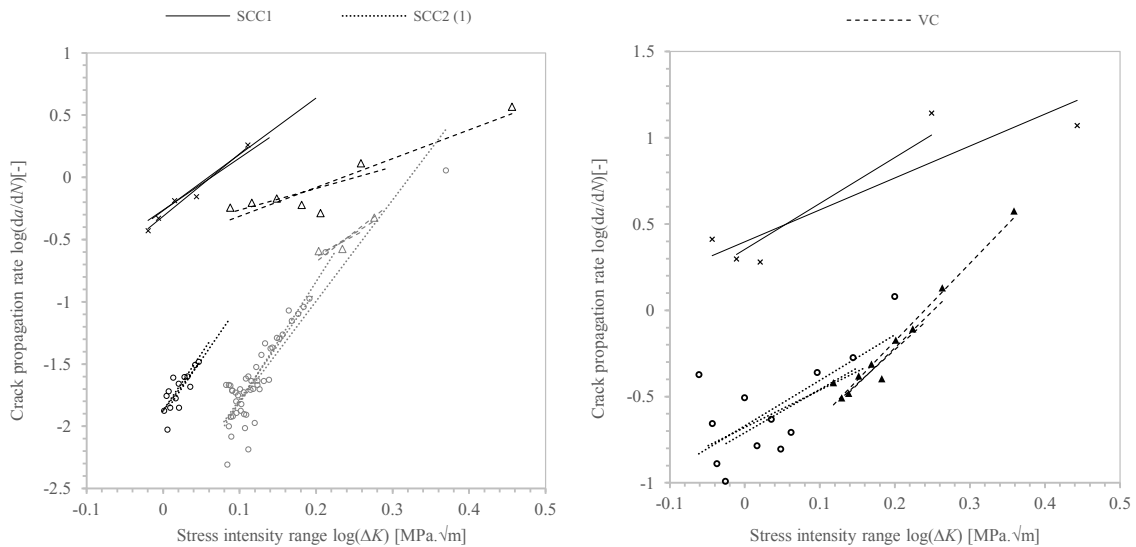

Fig. 5. (a) Fitting curves from 10-70% stress ratio 3PBT; (b) Fitting curves from 10-75% stress ratio 3PBT

From the fitting curves for the 10-70% stress ratio in Fig. 5a, it can be concluded that the average value m is smallest for VC, and the largest for SCC2. As a consequence, when ΔK increases, the crack propagation rate for SCC2 increases faster compared to VC and SCC1. In these tests, the average value C is the highest for SCC1. As a consequence, for

a fixed value of ΔK , the crack propagation for SCC1 is the largest. However, the validity of this conclusion could be questioned since the SCC1 test specimen failed after only 18 load cycles.

From the fitting curves for the 10-75% stress ratio, the following can be concluded: the average value of m is the largest for VC and smallest for SCC1, although the difference between SCC1 and SCC2 is rather small. As a consequence, when ΔK increases, the crack propagation for VC increases faster compared to SCC. Moreover, the average value C is greatest for SCC1. Therefore, for a fixed value of ΔK , the crack propagation SCC1 is the greatest. Similar to the 3PBT's for the 10-70% stress ratio, the validity of this conclusion can be questioned since the SCC1 test specimen failed after only 6 load cycles.

Table 1. Paris-Erdogan law parameters for all 3PBT's.

Stress ratio	Concrete	m	C	N_{tot}
10-70%	VC	2.0198	0.6141	25
		3.9681	0.2383	51
	SCC1	4.3519	0.7669	18
	SCC2	8.7660	0.1515	406
		8.8363	0.0685	678
10-75%	VC	4.2299	0.3558	30
	SCC1	2.2540	1.4563	6
	SCC2	2.4373	0.5037	65
10-80%	VC	-	-	2
	SCC1	-	-	1
	SCC2	4.8119	0.5969	39
10-90%	VC	-	-	3
	SCC1	-	-	1
	SCC2	2.4709	1.0796	9

5. Conclusions

In this contribution, the effect of the stress ratios on VC and two SCC types was numerically studied on based on test results from 3PBT samples. Despite the absence of data for certain stress ratios, the following conclusions can be drawn from this study:

- SCC1 has the highest overall value of parameter C , for both the 10-70 and 10-75% stress ratio. This implies that for a given stress intensity range ΔK , the crack propagation rate in SCC1 is larger, compared to VC and SCC2. Furthermore, the results for the 10-70 and 10-75% stress ratio show that SCC2 has the lowest overall value of C .
- For the 10-70% stress ratio, SCC2 has the highest value of m while VC has the lowest value, thus implying that when ΔK increases, the crack propagation in SCC2 rate increases the quickest. However, in the 10-75% stress ratio, VC has the greatest value of parameter m , while the m parameters of SCC1 and SCC2 are merely identical.
- Overall, SCC with comparable strength has the highest value of parameter C , while SCC with a comparable w/c-ratio has the lowest value. Furthermore, for the lowest 10-70% stress ratio, SCC2 has a higher value of parameter C , while in the 10-75% stress ratio VC has the highest value. The results do not always allow conclusions to be drawn. This might be caused by the fact that concrete is a heterogeneous material known to be prone to scatter in the results. Overall, it can be stated that SCC is more brittle than VC. This conclusion corresponds with the conclusions stated in the work of Korte et al [18-21] on which this numerical analysis is based.

Due to improved durability and decreased permeability, SCC performs better compared to VC in static loading conditions. However, when it comes to cyclic loading situations, SCC with a comparable strength is more brittle and repetitive loading leads to faster crack propagation compared to VC. Therefore, it can be stated that in the long run, VC outperforms SCC with equal strength. Therefore, precaution is required when using SCC with a similar strength in applications which involve cyclic loading. However, the graphs in Fig. 5. show that, especially for smaller values of ΔK , SCC with a comparable w/c-ratio outperforms VC. It can therefore be stated that SCC with a comparable w/c-ratio can be a valuable substitute for traditional VC in the protection of encased steel reinforcement, hence its improved durability and superior performance under cyclic loading.

Acknowledgements

The authors acknowledge the support of Czech Sciences foundation project No. 15- 07210S and Brno University of Technology Project No. FAST-S-16-3475. The research was conducted in the frame of IPMinfra supported through project No. LM2015069 of MEYS.

References

- [1] ANSYS Inc, ANSYS Parametric Design Language Guide. (14.0). Canonsburg, Pennsylvania, USA (2011).
- [2] B.L. Karihaloo, Fracture Mechanics and Structural Concrete. Hoboken, New Jersey, USA: Longman Scientific and Technical Publishers, John Wiley (1995).
- [3] D. Bonen, S.P. Shah, Fresh and hardened properties of self-consolidating concrete. *Progress in Structural Engineering and Materials* 7(1) (2005) 14–26.
- [4] D. Pryl, J. Mikolášková, R. Pukl, Modeling fatigue damage of concrete, *Key Engineering Materials*, 557-578 (2014) 385–388
- [5] G. De Schutter, K. Audenaert, Final report of RILEM TC 205-DSC: Durability of Self- Compacting Concrete. *Materials and Structures/Materiaux et Constructions* 41(2) (2008) 225–233.
- [6] G.V. Guinea, J.Y. Pastor, J. Planas, M. Elices, Stress intensity factor, compliance and CMOD for a general three-point-bend beam. *International Journal of Fracture*. 89(2) (1998) 103–116.
- [7] J. Charles, F. Crane, J. Furness, Fatigue. In *Selection and Use of Engineering Materials*. Oxford: Butterworth-Heinemann. (1997) 101–119.
- [8] J. de Oliveira e Sousa, T. Bittencourt, Experimental analysis of fracture processes in concrete. *Journal of the Brazilian Society of Mechanical Sciences* 23(4) (2001) 545–550.
- [9] J.J. Kruzic, R.M. Cannon, J.W. Ager, R.O. Ritchie, Fatigue threshold R-curves for predicting reliability of ceramics under cyclic loading. *Acta Materialia* 53(9) (2005) 2595–2605.
- [10] K. H. Khayat, G. De Schutter, Mechanical Properties of Self-Compacting Concrete. RILEM State-of-the-Art Reports, 2014.
- [11] L. Østergaard, L. Damkilde, H. Stang, Early-age fracture mechanics and cracking of concrete: Experiments and modeling. Denmark: Technical University of Denmark, Department of Civil Engineering. 2003.
- [12] L. Susmel, High-cycle fatigue of notched plain concrete. *Procedia Structural Integrity* 1 (2016) 2–9.
- [13] M. Ouchi, Self-compacting concrete: development, applications and key technologies, In *Proceedings of the Fourth International Conference on Materials Engineering for Resources* 58 (2001) Akita: Society of Materials Science Japan.
- [14] M.K. Lee, B.I. Barr, An overview of the fatigue behaviour of plain and fibre reinforced concrete. *Cement and Concrete Composites*. 26(4) (2004) 299–305.
- [15] P. C. Paris, F. Erdogan, A Critical Analysis of Crack Propagation Laws. *Journal of Basic Engineering* 85(4) (1963) 528–533.
- [16] R. Ince, K.E. Alyamaç, Determination of fracture parameters (K_{Ic} and $CTOD_c$) of plain concrete using three-point bend tests, *Indian Journal of Engineering and Materials Sciences* 15 (2008) 14–22.
- [17] R. Szecsy, N. Mohler, Self-Consolidating Concrete. Washington DC: Portland Cement Association (2009).
- [18] S. Korte, V. Boel, W. De Corte, G. De Schutter Comparative study on the fatigue behaviour of SCC and VC, *Key Engineering Materials* 627 (2015) 333–336.
- [19] S. Korte, V. Boel, W. De Corte, G. De Schutter, Behaviour of fatigue loaded self-compacting concrete compared to vibrated concrete, *Structural Concrete*, 15(4) (2014) 575–589.
- [20] S. Korte, V. Boel, W. De Corte, G. De Schutter, Static and fatigue fracture mechanics properties of self-compacting concrete using three-point bending tests and wedge-splitting tests. *Construction and Building Materials* 57 (2014) 1–8.
- [21] S. Korte. Experimental and Numerical Investigation of the Fracture Behaviour and Fatigue Resistance of Self-Compacting Concrete. Ghent, Belgium: Ghent University, Faculty of Engineering and Architecture (2014).
- [22] S.V. Kolluru, E.F. O’neil, J.S. Popovics, S.P. Shah, Crack Propagation in Flexural Fatigue of Concrete. *Journal of Engineering Mechanics* 126(9) (2000) 891–898.
- [23] Z.P. Bazant, K. Xu, Size Effect in Fatigue Fracture of Concrete. *ACI Material Journal* 88(4) (1991) 390–399.