



ELSEVIER

Available online at www.sciencedirect.com**SciVerse ScienceDirect**

Procedia Engineering 16 (2011) 772 – 781

**Procedia
Engineering**

www.elsevier.com/locate/procedia

International Workshop on Automobile, Power and Energy Engineering
**Design and Simulation Based on Pro/E for a Hydraulic Lift
Platform in Scissors Type**

Tian Hongyu^{*}, Zhang Ziyi

Beijing Union University, Beijing Chaowai baijiazhuang, Beijing 100020, China

Abstract

Scissors lift platform with a wide range, the main platform, lift mechanism and the bottom are composed of three parts. Lifting from low to high lifting, the scissors posts, and the hydraulic cylinder layout multiple, mobile way has traction, self-propelled, booster, etc. Scissors lift mechanism of scissors post number and cylinder layout by lifting height. This paper is about a design based 3D software Pro/E with 8m high scissors lift platform, which gives a entire platform dimension with 1800 × 900mm². A rated load of features so that the whole platform can be set up by two pairs of scissors refers to like products. The platform is designed to be folded away doors, to save more space for convenient storage. Lift platform uses a hydraulic driver, which runs smoothly, stably, and accuracy factors relative to high.

© 2010 Published by Elsevier Ltd. Selection and/or peer-review under responsibility of Society for Automobile, Power and Energy Engineering. Open access under [CC BY-NC-ND license](http://creativecommons.org/licenses/by-nc-nd/3.0/).

Keywords: Lift platform; hydraulic drive; 3D design; Pro/E ;

1. Introduction

Scissors lift platform is the one of the vertical lifting equipment, which can be used indoor or outdoor with a considerable extensive space. It can be used in the mechanical industries, automatic production lines, the basements and physical distribution lines and so on. In order to fulfill the more and more using areas, scissors lift platform must be given higher and higher loading capability, faster and faster moving velocity and more and more steady starting and stopping of the platform.

The scissors lift mechanism is the crucial constituent part of scissors lift platform, whose force characteristic will influence the performance of the whole equipment directly. Therefore, the most

^{*} Corresponding author. Tel.: +86- 13671195535.

E-mail address: jdthongyu@buu.edu.cn.

important problem for the designing the platform is to resolve the structure dimension of the main departments such as the scissors posts, the bottom car and the upper platform, the hydraulic control parts and the driving hydraulic cylinder.

There are many kinds of constructions for the scissors lift platform, but the main departments of the typical lift platform usually are the upper platform, the scissors posts and the bottom car. The numbers of the scissors posts and the position of the hydraulic cylinders even have different assortment, which determine the lifting height of the platform. In this paper, we give a height of 8m for the platform to lift. An about $1800 \times 900 \text{mm}^2$ areas will be given for the upper platform to lift enough matters and a bigger rated loading capability can be gained. There are three manners for the bottom car to move as for dragging, automatic running and force aiding. The whole platform is designed to have a pair of scissors mechanisms, which are put on the bottom car for two parts symmetrically. Each scissors mechanism has four posts pairs to fulfill the height requirement.

Using the three dimensions simulation software Pro/E, the mechanism design and simulation about the equipment of the scissors lift platform can be done just like the structures depicted upwards. The whole components' 3D modeling, the simulated assembling and mechanism simulating are extruded though the software. During these simulations, the check of interference between the components can be given perfectly, as well as the problems likely can be avoided, which can improve that the mechanism design we have done is reliable.

The design process of this mechanism simulation is given, which have several steps below, see figure 1 [1].

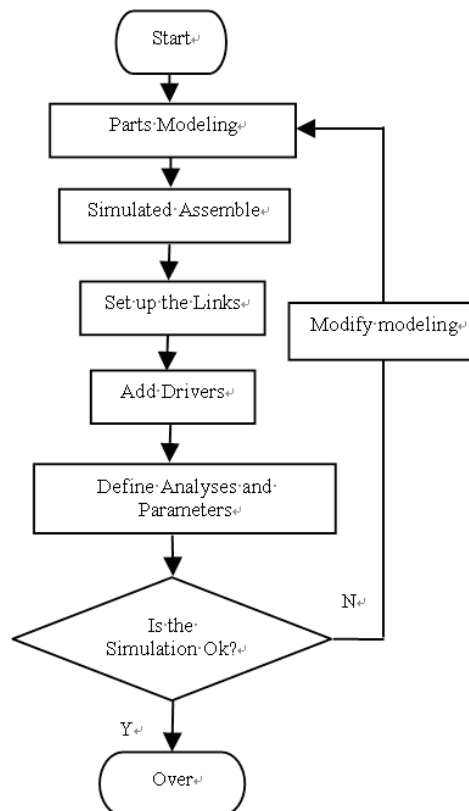

Fig. 1. Design process of simulation

2. The plan design and the parameters determination

In this design, an automatic running scissors lift platform is proposed, with the characteristic of the agility moving, lifting steadily, convenient operating, heavy carrying capacity etc..

2.1. The main parameters determination

The main parameters of the lift platform are described below.

- Rated carrying capacity with 500kg;
- Working height with 8m;
- Platform height with 6.2m;
- Platform areas with 1800×900mm²;
- Rated moving velocity upward with 6~9 m/min;
- Rated moving velocity downward with no more than 6 m/min.

The moving velocity analyzed below. See figure 2. And the different comparison result of platform moving velocity has been given when the driving cylinder velocity is 1 m/min or 5 m/min. Though the figure of table 1, we can conclude that the faster the cylinder velocity moves, the sharper the platform is lift.

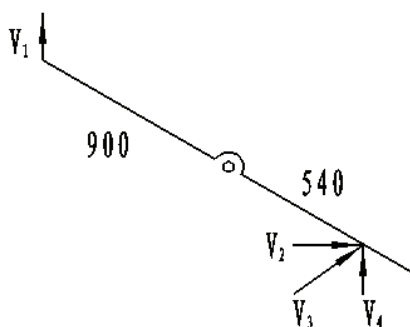

Fig. 2. velocity analyses

Table 1. Platform velocity comparison

Angle Degree	20°	30°	40°	50°	60°
cylinder velocity: 1m/min	0.51 m/min	0.75 m/min	0.96 m/min	1.15 m/min	1.30 m/min
cylinder velocity: 5m/min	9.6 m/min	6.6 m/min	5.13 m/min	4.31 m/min	3.81 m/min

When fix the platform velocity, the cylinder will gain a variable velocity. Because there had not given the limit to the upward velocity of the platform, we can choose the fixed hydraulic cylinder velocity and get a variable platform velocity for a simple design. So we apply the jack cylinder as the execution when design the hydraulic system, who can give a high strength and a suitable velocity upward which will not

exceed the prescribed velocity limit of national standard. As the platform moves downward, the speed control valve can guarantee the value of the platform velocity with 5 m/min then the cylinder gives 3.8 m/min velocity.

2.2. The plan design

Plan 1: two hydraulic cylinders driving type

In order to keep the platform's moving smoothly up and down, we can adopt two hydraulic cylinders type lift platform. See figure 3a. The cylinders are put vertically, which can save labors, give the scissors equality force. For the hydraulic system, using the type, the smaller pump working pressure is offering. The defect of this type is it needs the smoother floor because when the scissors posts are folded the cylinders are tending to touch the floor or other components.

Plan 2: one hydraulic cylinder driving type

In this type the hydraulic cylinder is put away (see figure 3b), which bring along the main post arm and others posts can move with the main one exploiting the hinge principle of mechanics. Without the equality force on the scissors posts, the equipment needs the bigger driving force than two hydraulic cylinders type. The advantage of the type is when the platform is folded more space is saving. But when starting the machine, the more heavy force must be given to the post in order to offer the bigger vertical force. So using this type platform, the higher pump working pressure must be offered to drive the hydraulic cylinder to extend.



Fig. 3. (a) two hydraulic cylinders driving type platform; (b) one hydraulic cylinder driving type platform

In consideration of the application in a popular style and the saving space, one hydraulic cylinder driving type platform is determined to be the optimal plan. Adopt this plan, the cost will be saved as the number of the cylinders using.

3. The structure design of the platform

Depending on the parameters needed, the pair numbers have been determined to be four, the whole mechanism schematic diagram can be given, see figure 4.

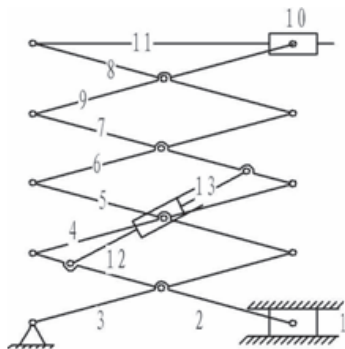

Fig. 4. mechanism schematic diagram of the platform

In view of the position of the hydraulic system and the space of the device according to the numbers from calculating, the inclined hydraulic cylinder structure is applied. See figure 5.

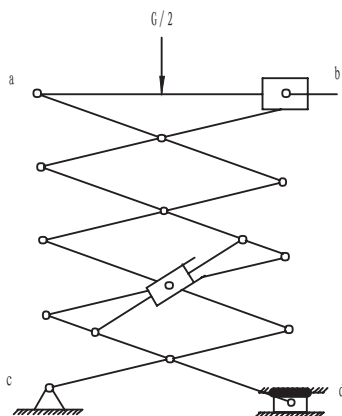

Fig. 5. inclined hydraulic cylinder structure

In the platform, point c is fixed with a ream support, and point b and d leave a sliding ream supports with the bottom and the upper platform each other. When the same structure is used at point b and d, the parameters of the friction is the same one and is express as the letter f. All the scissors posts have the same length expressed as the letter l, whose weight are ignored when analyzing the forces. The inclined driving hydraulic cylinder is fixed to two scissors posts at whose middle points, see figure 5.

Suppose that the included angle of the cylinder’s work line and the bottom is β , and α is the included angle from the inclined scissors post to the bottom. The weights of the platform itself and the load on the platform are added to be G , and the force point of the weight has a distance from the point b expressed with the letter p . When the whole machine goes up and down, the distance of p will not be changed. See figure 6.

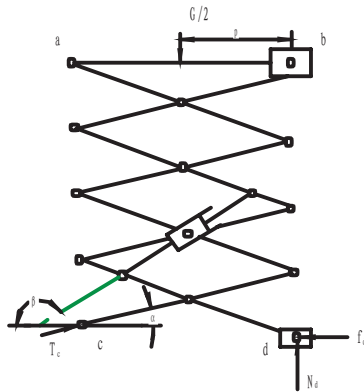

Fig. 6. the scissors posts force analysis

The first step of force analysis of the scissors mechanism is the analysis to the whole scissors platform. The weight G is distributed the two scissors mechanism, so the single one’s weight is $G/2$. The correlated forces are displayed below.

$$T_c \cdot \cos \alpha = f_d \tag{1}$$

$$T_c \cdot \sin \alpha + N_d = \frac{G}{2} \tag{2}$$

$$f_d = f \cdot N_d \tag{3}$$

The force analysis of upper platform can be seen in figure 7.

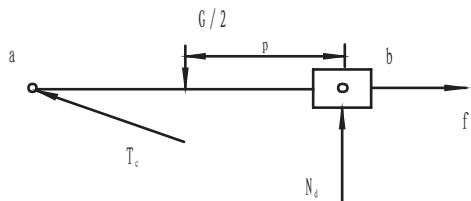

Fig. 7. the force analysis of the platform

$$T_{cx} = T_c \cdot \cos \alpha = f_d = f \cdot N_d \quad (4)$$

$$T_{cy} = T_c \cdot \sin \alpha \quad (5)$$

$$\frac{G}{2} = T_{cy} + N_d = T_c \cdot \sin \alpha + N_d \quad (6)$$

$$\frac{G}{2} \cdot p = T_{cy} \cdot l \cos \alpha \quad (7)$$

Through the force analysis and the cooperation calculation, the force demanded can be gained.

4. Modeling based on Pro/E

In traditional design of the mechanism, after the force analysis the design of the mechanical-drawing is a difficult work and will be spend most of the design time. But now, with the development of the computer technique, our design can be done on the computer, and the simulation of the mechanism can be seen before the prototype is born. Using the 3D software such as Pro/E, the whole time will be shorted and the design will be more scientific and with high feasibility.

In consideration of the placement of the platform, the platform is designed with two doors which can be folded when needed. The enclosure of the platform is welded with the $25 \times 25 \text{ mm}^2$ hollow heart posts, and the platform is made of steel sheet with the thickness of 6mm whose dimension is $1800 \times 900 \text{ mm}^2$, see figure 8.

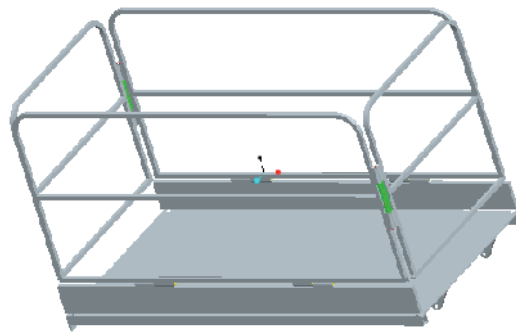

Fig. 8. the platform model

When the doors of the upper platform are opened, the biggest angle will be 270 degree, so as to obtain more commodious space, see figure 9.

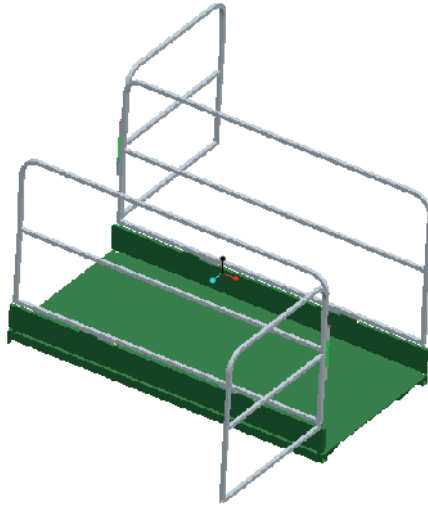

Fig. 9. side door opening model

Both the main enclosure and the two side doors can be folded together for bigger space, see figure 10.

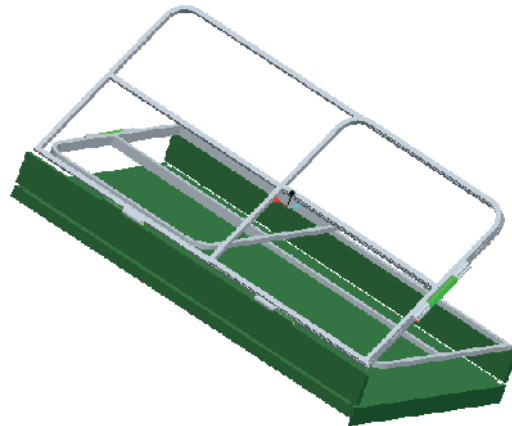

Fig. 10. the folded enclosure model

The whole lift platform is designed based the software Pro/E, through which permit us to simulate the mechanism .See figure 11.

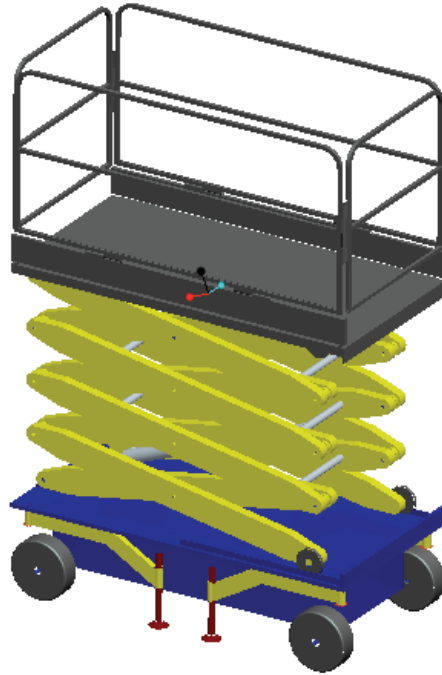

Fig. 11. the whole lift platform model

Through adjusting parameters of the motion included the drive motor parameters, moving time and the sequence of the movement, the perfect and satisfied simulation motion model can be obtained by the software Pro/E^[2].

Choose the interference check at the play again interface and set the whole check mode. There is not any interference district in the simulation modeling. This result is satisfied and ideal^[1, 3].

5. Conclusion

In this paper the design of a scissors lift platform based on Pro/E can be done such as the main components 3D modeling, visual assemble, interference checking etc., which help the designer find the problems in the 2D design^[4]. The model set up from the three dimension software expression the designer's idea sufficiently about the work.

Design technique face to assemble change a lot from traditional method of the production design, manufacture mode and assemble process. This technique makes the possibility of assemble and the using performance analyses in front of manufacture come to be true. It causes the problems to occur earlier which get out only through the sample machine^[5]. The design optimization, short cycle from design to manufacture, low development cost and the capacity of response to market are also can be gained through this technique.

References

- [1] National Research Council. Modeling and simulation in manufacturing and defense acquisition: pathway to success. USA: The National Academy Press, 2002.
- [2] Huang Weizhong. Application of Pro/E in Shear-sheet Machine Solid Modeling and Assembly Design. *Coal Mine Machine*, Vol.30, No.3, Mar. 2009.
- [3] Ge Jianbing. Movement Simulation of Z. B Combinatory Cam Mechanism Based on Pro/E. *Light Industry Machinery*, Vol.25, No.2, Apr. 2007.
- [4] Ge Jianbing. Movement Simulation of Z. B Combinatory Cam Mechanism Based on Pro/E. *Light Industry Machinery*, Vol.25, No.2, Apr. 2007 (In Chinese).
- [5] National Research Council. Modeling and simulation in manufacturing and defense acquisition: pathway to success. USA: The National Academy Press, 2002