

Report

Analysis of Mitochondrial DNA Diversity in the Aleuts of the Commander Islands and Its Implications for the Genetic History of Beringia

Olga A. Derbeneva,¹ Rem I. Sukernik,¹ Natalia V. Volodko,¹ Seyed H. Hosseini,² Marie T. Lott,² and Douglas C. Wallace²

¹Laboratory of Human Molecular Genetics, Institute of Cytology and Genetics, Siberian Division, Russian Academy of Sciences, Novosibirsk, Russia; and ²Center for Molecular Medicine, Emory University, Atlanta

The Aleuts are aboriginal inhabitants of the Aleutian archipelago, including Bering and Copper (Medny) Islands of the Commanders, and seem to be the survivors of the inhabitants of the southern belt of the Bering Land Bridge that connected Chukotka/Kamchatka and Alaska during the end of the Ice Age. Thirty mtDNA samples collected in the Commanders, as well as seven mtDNA samples from Sireniki Eskimos in Chukotka who belong to the Beringian-specific subhaplogroup D2, were studied through complete sequencing. This analysis has provided evidence that all 37 of these mtDNAs are closely related, since they share the founding haplotype for subhaplogroup D2. We also demonstrated that, unlike the Eskimos and Na-Dene, the Aleuts of the Commanders were founded by a single lineage of haplogroup D2, which had acquired the novel transversion mutation 8910A. The phylogeny of haplogroup D complete sequences showed that (1) the D2 root sequence type originated among the latest inhabitants of Beringia and (2) the Aleut 8910A sublineage of D2 is a part of larger radiation of rooted D2, which gave rise to D2a (Na-Dene), D2b (Aleut), and D2c (Eskimo) sublineages. The geographic specificity and remarkable intrinsic diversity of D2 lineages support the refugial hypothesis, which assumes that the founding population of Eskimo-Aleut originated in Beringian/southwestern Alaskan refugia during the early postglacial period, rather than having reached the shores of Alaska as the result of recent wave of migration from interior Siberia.

The Aleut people of the Eskimo-Aleut language group inhabit about a dozen of the hundred or so islands that extend from the Alaska Peninsula of North America to the Kamchatka Peninsula of northeastern Siberia. At present, there are several Aleut villages in the United States, as well as a group of Aleuts living on Bering Island in Russia (Black and Liapunova 1988). Archeological records of Kamchatka, Chukotka, and Alaska suggest that proto-Eskimo-Aleut culture derived from the remnants of fishing and sea mammal-hunting groups who survived in Beringia, southern Alaskan, and the Northwest Coast refugia at the end of the Last Glacial Maximum and in the postglacial period (Laughlin 1980; Rogers et al. 1991; Dikov 1994; West 1996). Therefore, they

are of great importance for understanding the evolution of both Siberian and Native American populations.

Analysis of mtDNA diversity in aboriginal populations of the Chukchi Peninsula and the adjacent coast of Alaska and British Columbia has revealed that they encompass haplogroups A and D, a subset of the four primary Native American haplogroups (A–D). Haplogroup A is the most prevalent in the Coastal Chukchi, Eskimos, and northern North American Indians, whereas D is the most prevalent among the Aleuts (Torrioni et al. 1993; Merriwether et al. 1995; Starikovskaya et al. 1998; Saillard et al. 2000).

In the first study, to our knowledge, of mtDNA variation in the Aleuts, which analyzed individuals from Saint Paul Island, 66.7% (38/57) fell into haplogroup D, whereas the remainder belonged to haplogroup A (Merriwether et al. 1995). More recently, the ancient mtDNAs representing Paleo- and Neo-Aleut remains in the Aleutian islands showed similar haplogroup frequencies (28%–42% A and 58%–71% D), regardless of geographic location (Hayes and O'Rourke 2001). However, the low-resolution RFLP analysis used in these studies did not permit elucidation of internal sequence

Received March 7, 2002; accepted for publication May 9, 2002; electronically published June 25, 2002.

Address for correspondence and reprints: Dr. Rem I. Sukernik, Laboratory of Human Molecular Genetics, Institute of Cytology and Genetics, 10 Lavrent'ev Ave, Novosibirsk 630090, Russia. E-mail: sukernik@bionet.nsc.ru

© 2002 by The American Society of Human Genetics. All rights reserved. 0002-9297/2002/7102-0021\$15.00

variation in the Aleut haplogroup D lineages, thus making it impossible to elucidate the specific relationships with the sublineages of haplogroup A and D defined in the Chukchi and Eskimos (Starikovskaya et al. 1998; Saillard et al. 2000). To address the question of the origin of the Eskimo-Aleut linguistic group of Beringia, we have surveyed the mtDNA variation in the remaining Aleuts of the Commander Islands.

The Commanders are two islands off the coast of Kamchatka, the inhabitants of which encompass the descendants of the two main dialect groups of the Aleutian native population (Jochelson 1933; Lyapunova 1975). The Aleutian archipelago, including Bering and Copper (Medny) Islands of the Commanders, was discovered by the Bering-Chirikov expedition in 1741 (fig. 1). Subsequent contact with Russians, the first Europeans to visit the Aleutian Islands and Alaska, led to a precipitous decline in the size of the native population. Prior to contact, the Aleut population was estimated to be 8,000–16,000. By 1820–1821, it had shrunk to <1,500 individuals (Veniaminov 1840). In 1825–1826, the Russian-American company transferred Aleut families from Attu Island, the westernmost of the Aleutian chain, as well as from Atka/Andreyanov Islands, to the Com-

manders. In 1840, to increase the number of sea otter hunters, additional settlers were brought from Saint Paul and Fox Islands, as well as from Sitka (Jochelson 1933). In 1879, 168 nonadmixed Aleuts lived on the Commander Islands, with ~100 of these on Copper Island.

Today, the Aleut community of the Commanders numbers ~300 individuals. Although this population has become extensively admixed with Russians, quite a few families can trace their Aleutian ancestry through the maternal side. Accordingly, we collected blood samples from individuals in the village of Nikolskoye on Bering Island (Aleutskiy district, Kamchatkan region, Russian Federation), most of whom reported Aleut ancestry on their maternal line but a few of whom were uncertain about their Aleut or Native American ancestral continuity. Approximately half of the current residents of Nikolskoye were born on Copper Island, in the village of Preobrazhenskoye, which no longer exists.

In the present study, 30 mtDNAs collected in the Commanders were subjected to complete sequencing. The procedure entailed PCR amplification of 10 overlapping mtDNA fragments that were then sequenced in both forward and reverse directions by use of BigDye Terminator chemistry (PE Applied Biosystems). Electropho-

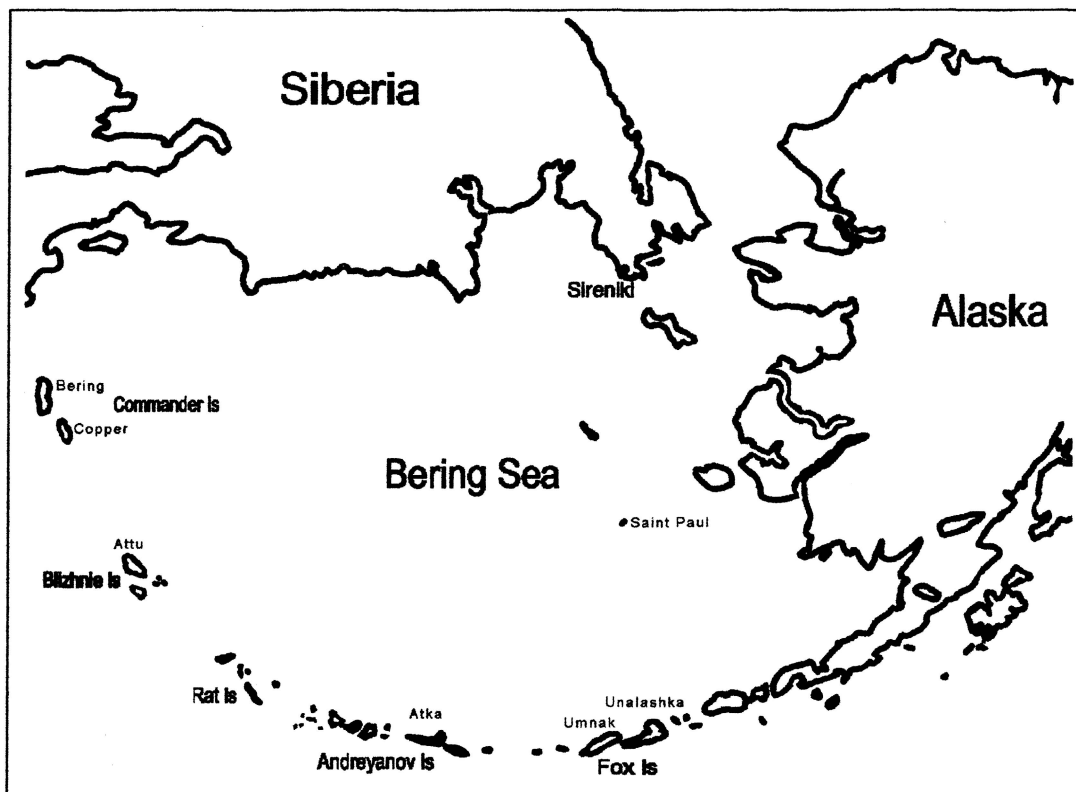

Figure 1 Map of the Bering Sea region, showing locations of the Commander and Aleutian Islands

M	Aleuts									Eskimos					
	D2b							D2	D2a	D2 ^{other}		D2c			
	I (n=13)	II (n=4)	III (n=3)	IV (n=3)	V (n=1)	VI (n=1)	VII (n=1)	VIII (n=3)	IX (n=1)	X (n=1)	XI (n=1)	XII (n=3)	XIII (n=1)	XIV (n=1)	
73	3316	3316	3316	3316	3316	3316	3316	3316	3316	3316	3316	3316	3316	795	
263	<u>4883</u>	<u>4883</u>	<u>4883</u>	<u>4883</u>	<u>4883</u>	<u>4883</u>	<u>4883</u>	<u>4883</u>	<u>4883</u>	<u>4883</u>	<u>4883</u>	<u>4883</u>	<u>4883</u>	3316	
489	<u>5178A</u>	<u>5178A</u>	<u>5178A</u>	<u>5178A</u>	<u>5178A</u>	5081	<u>5178A</u>	<u>5178A</u>	<u>5178A</u>	<u>5178A</u>	4991	4991	<u>5178A</u>	<u>5178A</u>	<u>4883</u>
750	7493	6554	7493	7493	7493	7493	<u>5178A</u>	7493	7493	7493	<u>5178A</u>	<u>5178A</u>	7493	7403	<u>5178A</u>
1438	<u>8414</u>	7493	<u>8414</u>	<u>8414</u>	<u>8414</u>	7493	<u>8414</u>	<u>8414</u>	<u>8414</u>	<u>8414</u>	7493	7493	<u>8414</u>	7493	7493
2706	8703	<u>8414</u>	8703	8703	8460	<u>8414</u>	8703	8703	8703	8703	<u>8414</u>	<u>8414</u>	8703	<u>8414</u>	<u>8414</u>
3010	8910A*	8639	8910A*	8910A*	8703	8703	8910A*	9536	9536	9536	8703	8703	9536	8703	8703
4769	9536	8703	9536	9536	8910A*	8910A*	9536	11215	11215	11215	9536	9536	9667	9536	8895
7028	9667	8910A*	9667	9667	9536	9536	9667	11959	11959	11959	11215	11215	11215	9667	9536
8701	11215	9536	11215	11062	9667	9667	10695	<u>14668</u>	<u>14668</u>	11959	11959	11959	11215	9667	9667
8860	11959	9667	11959	11215	11215	11215	11113	16129	16092	16092	<u>14668</u>	<u>14668</u>	<u>14668</u>	11959	11215
9540	<u>14668</u>	11215	<u>14668</u>	11959	11959	11959	11215	16271	16129	16129	16129	16111	<u>14668</u>	11959	11959
10398	16129	11959	16129	<u>14668</u>	<u>14668</u>	<u>14668</u>	11959	16362	16271	16271	16271	16129	16129	16111	<u>14668</u>
10400	16271	<u>14668</u>	16271	16129	16129	16129	<u>14668</u>				16362	16271	16271	16129	16111
10873	16362	16129	16362	16271	16271	16271	16129					16362	16362	16271	16129
11719		16271	16519	16362	16362	16362	16271						16366	16362	16271
12705		16311					16362							16366	16294
14766		16362											16519	16362	16362
14783															16366
15043															
15301															
15326															
16223															

Figure 2 Lineage D2 sequence variation in Aleuts and Siberian Eskimos. “M” is macrohaplogroup M, which is shared by all of the Aleut and Eskimo mtDNA samples. Four diagnostic variants for haplogroup D mtDNAs are underlined. These were inferred through comparisons with four complete sequences (three Native Siberian and one Native American mtDNA) belonging to haplogroup D lineages other than D2, as well as with the data given by Herrnstadt et al. (2002). Asterisks (*) indicate the Aleut-specific 8910A transversion. Only those nucleotide positions that differ from the Cambridge Reference Sequence (Andrews et al. 1999) are shown. Mutations are transitions, unless specified explicitly. The Aleuts were sampled in the Commanders, and the Eskimo sample consists of Sireniki Eskimos from the Chukchi Peninsula. Note that site 8683 *AluI*+, reported by Starikovskaya et al. (1998), was incorrectly mapped and, instead, is 8700 *AluI*+ (because of transitions at nps 8701 and 8703).

resis was performed using an ABI 3100 sequencer with 96 capillaries. Sequence analysis and comparison to the Cambridge Reference Sequence were performed by use of the program Sequencher (version 4.0.5, GeneCode). The primers used for PCR amplification and sequencing are given in online-only tables 1 and 2.

All of the 30 Commander sequences were found to contain 3316A, 16129A, and 16271C, thus indicating relevance to subhaplogroup D2, as classified by Forster et al. (1996) and, more recently, by Saillard et al. (2000), using the RFLP and hypervariable segment I (HVS-I) data of Starikovskaya et al. (1998). In addition, seven mtDNAs from Siberian (Sireniki) Eskimos in Chukotka, attributable to D2 on the basis of high-resolution RFLP analysis and HVS-I sequences (Starikovskaya et al. 1998), were also subjected to complete sequencing. Finally, four haplogroup D mtDNAs with different haplotypes, including one Nganasan of the Taimir Peninsula, two Ulchi of the Lower Amur River in Siberia, and one Central American mtDNA, also were completely sequenced. Comparison of

these sequences revealed that all harbor the sequence variants of macrohaplogroup M, and their characteristic haplogroup D markers in the coding region are 4883, 5178A, 8414, and 14468 (fig. 2).

All of the 37 Commander and Sireniki mtDNAs are closely related, since they share 3316A, 7493T, 8703T, 9536T, 11215T, 11959G, 16129A, and 16271C, thus forming the founding haplotype for a lineage D2 (sequence type VIII in figs. 2 and 3). This particular sequence type, as such, was defined in only 3 of 30 Commander mtDNA complete sequences. Intriguingly, one of the Commander mtDNA samples (type IX in figs. 2 and 3) has the 16092C variant, resulting in the 16092C, 16129A, 16223T, 16271C, 16362C sequence motif in the end of mtDNA molecule, previously described in one Na-Dene Indian (Apache) haplogroup D mtDNA sample that was studied through RFLP/HVS-I analysis (Torroni et al. 1993). Indeed, a few families in the Commanders reported Eskimos and/or American Indians as being in their remote ancestry, consistent with the historical rec-

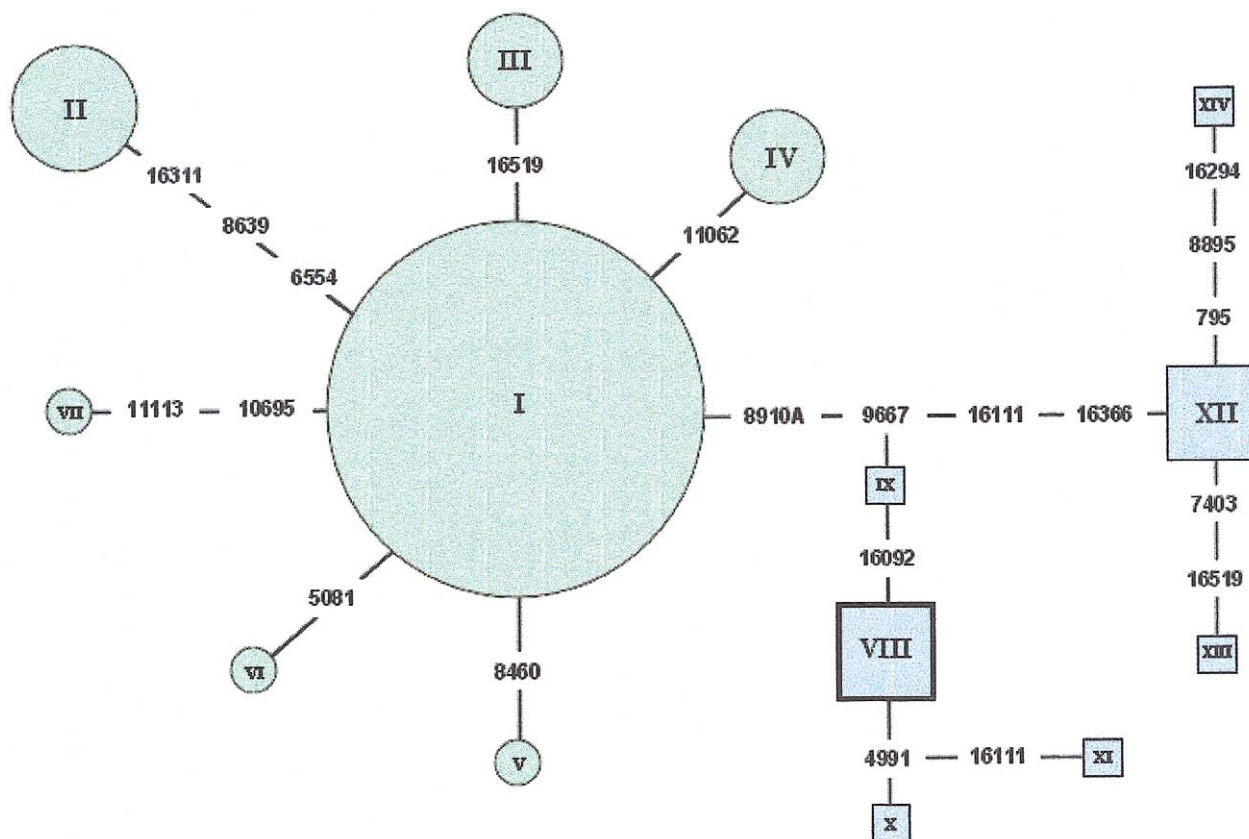

Figure 3 Schematic phylogenetic representation of the sequence types, numbered from I to XIV. The sizes of the circles (Aleuts) and squares (non-Aleuts) are proportional to the number of individual mtDNA samples. The 8910A mutation is a transversion. The rest of the mutations are transitions. The founding sequence type (VIII) for lineage D2 is shown in the square with a bold outline.

ords noted by Jochelson (1933). We have designated this lineage “D2a.” It is most likely that D2a has derived from the Na-Dene tribes of southern Alaska or the adjacent Northwest Coast, since historical records indicate that some Alaskan natives, including Kodiak Eskimo and Tlingit women, were brought to the Commanders by the Russian-American Company in 1840 (Jochelson 1933). The remaining 26 Commander mtDNA samples harbored a unique coding-region mutation, 8910A, which has not been reported elsewhere. Thirteen of these 8910A sequences are identical (type I in fig. 2). Since the Commander Aleut sample is an amalgamation of the eastern and western Aleutian populations sampled, the 8910A mutation must define the founding haplotype for the distinct Aleut D lineage that we designated as Aleut-specific D2b. The remaining Aleut mtDNA samples with the 8910A variant harbored one to three additional transitions: 6554T-8639C-16311C; 16519C; 11062T; 8460G; 5081C; and 10695A-11113C (types II–VII in figs. 2 and 3).

Hence, all of the Siberian Eskimo mtDNAs of haplogroup D2 sequenced in the present study lacked the

8910A mutation. This transversion was also absent in the Eskimo (“Siberian Inuit”) mtDNA sequenced by Ingman et al. (2000), and our Siberian Eskimo mtDNA sample (sequence type XIII in fig. 2) is identical to the one they reported. The mtDNA sequences of the Aleutian mtDNA D2b lineage show only occasional polymorphisms in the coding and control regions, whereas the Eskimo haplogroup D2 lineages exhibit extensive variation in the control region. The differentiation between modern Eskimo and Aleut mtDNA pools is further supported by the presence of lineage D3, which is found at low frequencies in the Chukchi and Siberian Eskimos (haplotype SIB40 in Starikovskaya et al. 1998) but not in the Aleuts. Lineage D3, which is distinguished by 239C, 297G, 951A, 10181T, 15440C, and 16319A, has also been observed in the Uralic-speaking Mansi and Nganasans, Tungusic-speaking Evenks and Ulchi, and Turkic-speaking Tuvan (Derbeneva et al. 2002; authors’ unpublished data). However, lineage D3 has not been reported in Native Americans and apparently arose in mainland Siberia, reflecting minor and relatively recent migration into the Bering Strait area.

A nucleotide variant of the D cluster defined in the Central American mtDNA sample is distinguished by 2092T, 9966A, 11092G, 14459A, 16291T and 16325C. We have called this lineage “D^{CA}” (Central American), since it is distinctly different from the remaining lineage D complete sequences, which also include two D Ulchi mtDNA samples from the Lower Amur (given in the caption to fig. 4). Consequently, the mutations specific to D^{CA} must have arisen among the earliest inhabitants of Beringia who passed further inland to the New World to become Central and South American Indians. The phylogeny of the haplogroup D cluster also shows that the Na-Dene are genetically closer to the Eskimo-Aleut than are the rest of the American Indians. It demonstrates that the Aleuts were founded by a single lineage of haplogroup D2, which had acquired the novel transversion mutation 8910A. Phylogenetic reconstruction makes it clear that the Aleut 8910A sublineage of D2

was part of a larger radiation of rooted D2 that gave rise to D2a (Na-Dene), D2b (Aleut), and other D2 types restricted to Sireniki Eskimos (figs. 2 and 4). It is apparent that the 4883, 5178A, 8414, and 14468 mutations represent a founding haplotype for all Native American and Native Siberian haplogroup D mtDNAs, the most recent common ancestor of D2, D3, and D^{CA}, and logic dictates that we term it “D^F.” Note that two of the seven Sireniki Eskimo sequences (X and XI) differed from the founding D2 lineage by the presence of a transition at nucleotide position (np) 4991 (a private polymorphism). On the other hand, both lack the 9667 mutation, which is ubiquitously present in the Aleuts that have the 8910A transversion. It is possible that the sequences lacking the 9667 mutation (VIII–XI) originated in different parts of the North Pacific and may represent a separate sublineage of D2 that is ancestral to both the Eskimos and the Na-Dene Indians. Since five

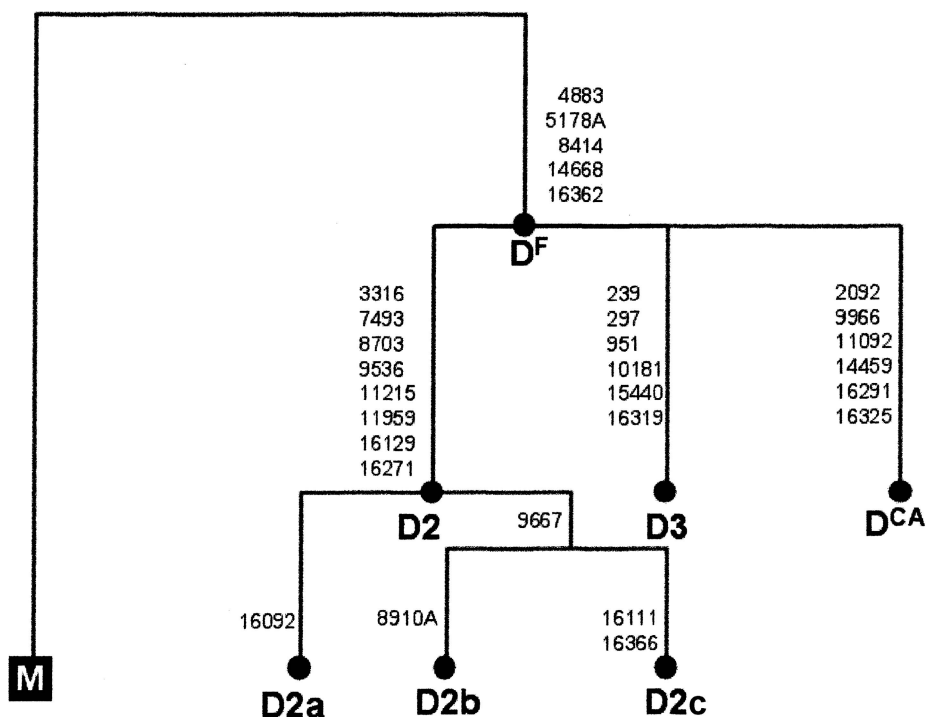

Figure 4 Intraspecific phylogeny of haplogroup D, rooted with the macrohaplogroup M haplotype as an outgroup, which, in turn, has been inferred from the complete sequences of Siberian haplogroup C, D, Z, and G mtDNAs and an American Indian D mtDNA sample. The complete sequences of three Siberian and one Native (Central) American used for phylogenetic reconstructions are as follows—Ulchi number 1: 73, 195, 263, 489, 750, 1438, 2706, 3010, 4769, 4883, 4907, 5178A, 7028, 8414, 8701, 8860, 9077, 9540, 10398, 10400, 10646, 10873, 11719, 12705, 13812, 14016, 14668, 14766, 14783, 15043, 15301, 15326, 16093, 16223, 16232, 16290, 16362; Ulchi number 2: 73, 263, 489, 750, 961, 1438, 2706, 3010, 3336, 3644, 4769, 4883, 5048, 5178A, 7028, 8269, 8414, 8701, 8860, 9540, 10398, 10400, 10873, 11719, 12705, 13879, 14668, 14766, 14783, 15043, 15236, 15301, 15326, 16223, 16278, 16325, 16362, 16519; Nganasan: 73, 239, 263, 297, 489, 722, 750, 951, 1438, 2706, 3010, 4023, 4769, 4883, 5178A, 6374, 7028, 8020, 8414, 8701, 8860, 9540, 9785, 10181, 10398, 10400, 10873, 11719, 12705, 14034, 14668, 14766, 14783, 15043, 15301, 15326, 15440, 15951, 16223, 16319, 16362; and Native American: 73, 263, 489, 750, 1438, 2092, 2706, 3010, 4769, 4883, 5178A, 7028, 8414, 8701, 8860, 9540, 9966, 10398, 10400, 10873, 11092, 11719, 12705, 13879, 14459, 14668, 14766, 14783, 15043, 15301, 15326, 16223, 16291, 16325, 16362, 16519. Mutation positions, relative to the Cambridge Reference Sequence (Andrews et al. 1999), are transitions unless the base change is specified.

of the seven Sireniki Eskimo mtDNA samples (sequences XII–XIV) harbored, in addition to the 9667 mutation, two additional transitions, at nps 16111 and 16366, this implied the presence of a new sublineage, which we termed “D2c” (figs. 2 and 4).

Since the Eskimo mtDNA gene pool is also conspicuous in its variety of haplogroup A2 sublineages (Starikovskaya et al. 1998; Saillard et al. 2000), it is apparent that the mitochondrial genome has shown greater diversity in the Eskimo populations than in those of the Aleuts of the Commanders. Unlike the Aleuts of Saint Paul Island, who harbored haplogroup A mtDNAs (Merriwether et al. 1995), this haplogroup has not been found in the inhabitants of the Commanders. It is apparent that haplogroup A mtDNAs were present in the parental Aleut groups residing on the Aleutians (Hayes and O’Rourke 2001) but then were lost through genetic drift, because of the genocide of the natives at the end of 18th century.

As has been suggested elsewhere (Forster et al. 1996; Starikovskaya et al. 1998) on the basis of haplogroup A analysis, the contemporary populations of the northern Pacific Rim may all have been derived from restricted geographic areas, including Beringia and southern Alaska coast refugia. We have now shown that the distribution of haplogroup A2 lineages observed in the former Beringia (Starikovskaya et al. 1998) is mirrored in the radiation of haplogroup D2. Both the A2 and D2 lineages may represent the remnants of the mtDNA gene pool of initially subdivided coastal populations of early Beringians persisting in a highly restricted geographic area. The geographic specificity and remarkable intrinsic diversity of the D2 lineage support the refugial hypothesis, which assumes the origin of the founding population of Eskimo-Aleut to be in the Beringian/southwestern Alaskan refugia during the early postglacial period, ~15,000 years ago (Rogers et al. 1991), rather than reaching the shores of Alaska as the result of recent wave of migration from interior Siberia ~6,000 years ago (Greenberg et al. 1986; Fortescue 1998).

The acquisition of the 8910A transversion by prehistoric Aleuts and the availability of complete sequences make it possible to reestimate the mtDNA mutation rate. Radiocarbon dates indicate that the earliest Aleut settlement (the Anangula site, with an entirely unifacial lithic tradition) existed at 8,750 years before present (West 1996). The mutations radiating from the founder Aleut 8910A haplotype include nine base substitutions in 16,569 bases. The resulting ratio, expressed as a percentage, is 0.054%. Therefore, assuming a simple model of neutral evolution with a uniform molecular clock, we can estimate the mtDNA nucleotide substitution rate to be 3.2% per million years. As a result, the variation that had accumulated within haplogroup D since its putative origin in the Lower Amur region could be quantified with

previously unattainable precision and accuracy, as soon as more complete haplogroup D sequences are available from the native people still residing on both sides of the Bering Strait.

Acknowledgments

We are indebted to Aleut people of the Nikolskoye village on Bering Island, who, through informed consent, allowed us to draw blood and provided us with family histories, and to Drs. Kim I. Borisov and Evdokiya I. Nozhikova and the personnel of Nikolskoye Hospital, for their help and hospitality. Special thanks to Matthew Molnar for his excellent technical assistance. We are also indebted to Dr. Robert S. Hoffmann (Smithsonian Institution, Washington D.C.), for discussions of the biogeographic influence of Beringian and southern Alaskan refugia on the genetic diversity of Native Americans in the early postglacial period and for valuable comments on an earlier draft of this manuscript. This research received support from National Institutes of Health grants TW1175 (to R.I.S.) and NS21328, AG13154, NS41850, and HL64017 (all to D.C.W.).

References

- Andrews RM, Kubacka I, Chinnery PF, Lightowlers RN, Turnbull DM, Howell N (1999) Reanalysis and revision of the Cambridge reference sequence for human mitochondrial DNA. *Nat Genet* 23:147
- Black LT, Liapunova RG (1988) Islanders of the North Pacific. In: Fitzhugh WW, Crowell A (eds) *Crossroads of continents: cultures of Siberia and Alaska*. Smithsonian Institution Press, Washington, DC, pp 52–57
- Derbeneva OA, Starikovskaya EB, Wallace DC, Sukernik RI (2002) Traces of early Eurasians in the Mansi of northwest Siberia revealed by mitochondrial DNA analysis. *Am J Hum Genet* 70:1009–1014
- Dikov N (1994) The Paleolithic of Kamchatka and Chukotka and the problem of the peopling of America. In: Fitzhugh WW, Chausonet V (eds) *Anthropology in the Pacific Rim*. Smithsonian Institution Press, Washington, DC, pp 87–95
- Forster P, Harding R, Torroni A, Bandelt H-J (1996) Origin and evolution of Native American mtDNA variation: a reappraisal. *Am J Hum Genet* 59:935–945
- Fortescue M (1998) *Language relations across Bering Strait: reappraising the archeological and linguistic evidence*. Cassel, New York
- Greenberg JH, Turner CG II, Zegura SL (1986) The settlement of the Americas: a comparison of the linguistic, dental and genetic evidence. *Curr Anthropol* 27:477–497
- Hayes MG, O’Rourke DH (2001) Genetic signatures of migrations and population replacements during human colonization of the North American Arctic. *Am J Hum Genet Suppl* 69:179
- Herrnstadt C, Elson JL, Fahy E, Preston G, Turnbull DM, Anderson C, Ghosh SS, Olefsky JM, Beal MF, Davis RE, Howell N (2002) Reduced-median-network analysis of complete mitochondrial DNA coding-region sequences for the

- major African, Asian, and European haplogroups. *Am J Hum Genet* 70:1152–1171
- Ingman M, Kaessmann H, Pääbo S, Gyllenstein U (2000) Mitochondrial genome variation and the origin of modern humans. *Nature* 408:708–713
- Jochelson W (1933) *History, ethnology, and anthropology of the Aleut*. Carnegie Institution of Washington, Washington
- Laughlin WS (1980) *Survivors of the Bering Land Bridge*. Holt, Rinehart and Winston, New York
- Lyapunova RG (1975) *Essays on the ethnology of the Aleut (Ocherki po etnografii aleutov)*. Nauka, Leningrad (in Russian)
- Merriwether DA, Rothhammer F, Ferrell RE (1995) Distribution of the four founding lineage haplotypes in Native Americans suggests a single wave of migration for the New World. *Am J Phys Anthropol* 98:411–430
- Rogers RA, Rogers LA, Hoffmann RS, Martin LD (1991) Native American biological diversity and the biogeographic influence of Ice Age refugia. *J Biogeogr* 18:623–630
- Saillard J, Forster P, Lynnerup N, Bandelt H-J, Norby (2000) mtDNA Variation among Greenland Eskimos: the edge of the Beringian expansion. *Am J Hum Genet* 67:718–726
- Starikovskaya YB, Sukernik RI, Schurr TG, Kogelnik AM, Wallace DC (1998) Mitochondrial DNA diversity in Chukchi and Siberian Eskimos: implications for the genetic history of ancient Beringia and the peopling of the New World. *Am J Hum Genet* 63:1473–1491
- Torroni A, Schurr TG, Cabell MF, Brown MD, Neel JV, Larsen, Smith DG, et al (1993). Asian affinities and continental radiation of the four founding Native American mtDNAs. *Am J Hum Genet* 53:563–590
- Veniaminov I (1840) *Notes on the islands of the Unalashka district*. Vols 1–3 (*Zapiski ob ostrovah Unalashkinskogo Otdela*). Russian-American Company, Saint Petersburg (in Russian)
- West FH (1996) *American beginnings, the prehistory and paleoecology of Beringia*. University of Chicago Press, Chicago