



FACULTY OF ENGINEERING
ALEXANDRIA UNIVERSITY

Alexandria University
Alexandria Engineering Journal

www.elsevier.com/locate/aej
www.sciencedirect.com



ORIGINAL ARTICLE

Investigation of emissions and combustion characteristics of a CI engine fueled with waste cooking oil methyl ester and diesel blends



K. Nantha Gopal ^{a,*}, Arindam Pal ^a, Sumit Sharma ^a, Charan Samanchi ^a,
K. Sathyanarayanan ^a, T. Elango ^b

^a School of Mechanical and Building Sciences, VIT University, Vellore 632014, Tamil Nadu, India

^b Dhanalakshmi Srinivasan College of Engineering, Thuraiyur Road, Perambalur, Tamil Nadu, India

Received 13 December 2013; revised 11 February 2014; accepted 23 February 2014

Available online 19 March 2014

KEYWORDS

Transesterification;
Waste cooking oil;
Waste cooking methyl ester;
Performance;
Exhaust emission;
Combustion;
Biodiesel

Abstract Biodiesel has been identified as a potential alternative fuel for CI engines because use of biodiesel can reduce petroleum diesel consumption as well as engine out emissions. Out of many biodiesel derived from various resources, biodiesel from Waste Cooking Oil (WCO) can be prepared economically using usual transesterification process. In the present study, in-depth research and comparative study of blends of biodiesel made from WCO and diesel is carried out to bring out the benefits of its extensive usage in CI engines. The experimental results of the study reveal that the WCO biodiesel has similar characteristics to that of diesel. The brake thermal efficiency, carbon monoxide, unburned hydrocarbon and smoke opacity are observed to be lower in the case of WCO biodiesel blends than diesel. On the other hand specific energy consumption and oxides of nitrogen of WCO biodiesel blends are found to be higher than diesel. In addition combustion characteristics of all biodiesel blends showed similar trends when compared to that of conventional diesel.

© 2014 Production and hosting by Elsevier B.V. on behalf of Faculty of Engineering, Alexandria University.

1. Introduction

Industrialization and growing population have pushed the nation to confront with twin crisis of fossil fuel depletion and environmental degradation. Indiscriminate extraction and lavish consumption of petroleum reserves have led to reduction of carbon resources [1]. An alternative energy resource like biodiesel from edible and non-edible oils such as soya beans, jatropha (*Jatropha curcas*), sunflower and karanja (*Pongamia Pinnata*), palm and neem has started attracting significant attention of researchers, governments and industries as

* Corresponding author. Tel.: +91 4162202267; fax: +91 416 2243092/2240411.

E-mail address: nanthagopalk@yahoo.com (K. Nantha Gopal).

Peer review under responsibility of Faculty of Engineering, Alexandria University.



Production and hosting by Elsevier

renewable, biodegradable, and non-toxic energy source. Several studies conducted by researchers identify that biofuels as a potential alternative fuel for internal combustion engines [2–5]. They have acclaimed to have zero net production of CO₂ gas in global context. It has been found that engines running on biodiesel run successfully for longer durations and the performance and emission characteristics are quite comparable to that of petroleum based diesel fuel [6–8]. Kalligeros et al. [9] conducted the test with biodiesel produced from sunflower and olive oils in a single cylinder stationary diesel engine and observed lower particulate matter (PM), carbon monoxide (CO), unburned hydrocarbon (UBHC) and nitrogen oxides (NO_x) emissions with a slight increase in fuel consumption. Yuceer et al. [10] investigated the performance and emission trends of biodiesel obtained from leather industry pre-fleshings and found that performance trends were quite similar to that of petroleum diesel with a considerable reduction in particulate and CO emissions. Conversely use of edible and non-edible vegetable oil makes the process of production of biofuels expensive. A study on production of biodiesel from various resources that survey reveals that the feedstock alone costs almost 75% of the total cost of production of biodiesel [11]. So cheaper raw materials are required to bring down the cost of biodiesel.

Repeated frying for preparation of food makes the edible vegetable oil, no longer suitable for consumption due to free fatty acid (FFA) content [12]. In addition waste cooking oil also brings many disposal problems all around the world by polluting river water, choking of drainage, etc. So, use of WCO may bring in many benefits if it is used as a fuel source. Thus production of biodiesel from waste cooking oil is one of the better ways to utilize it efficiently and economically eliminating the disposal related problems [13].

Presently, India produces only 30% of the total petroleum fuels required and the remaining 70% is imported, which costs about Rs. 80,000 million per year. It is evident that mixing of 5% of biodiesel fuel to the present diesel fuel can save Rs. 40,000 million per year. It is also estimated that India can supplement 41.14% of the total diesel fuel consumption, if resources like waste cooking oil and other bio wastes were used as raw material for biodiesel production [14]. Due to renewable in nature, low cost and green house gas reduction potential biodiesel is nowadays incorporated all over the world especially in developed countries like USA, France, Brazil in different proportions with diesel.

Waste cooking oil cannot be used directly in diesel engines as it has higher viscosity, free fatty acid and moisture content with low volatility leading to severe engine deposits, injector

coking and piston ring sticking [15,16]. These undesirable effects can be removed by transesterification of waste cooking oil. The process of transesterification removes glycerin from the triglyceride molecules present in waste cooking oil and replaces it with alcohol used in the process. The viscosity is decreased without much affecting the cetane number and the heating values. The chemical reaction of transesterification is shown in Fig. 1. Product of the reaction is methyl ester. In stoichiometric reaction, three moles of carbinol is required for one mole of triglycerides, however this being a reversible reaction, excess carbinol is required to shift the equilibrium to the product side. The base catalyzed transesterification has been selected rather than an acid catalyzed transesterification due to high conversion rate [4–6]. The data on requirement of petroleum diesel and availability of waste cooking oil in any country indicate that biodiesel obtained from waste cooking oil may not replace petroleum diesel completely. However, a substantial amount of biodiesel fuel can be prepared from waste cooking oil, which would partially decrease the dependency on petroleum based diesel.

2. Materials and methods of biodiesel preparation

2.1. Source

The primary raw material for biodiesel preparation used is waste cooking oil, which was collected from different sources such as hostels, restaurants, canteen and cafeterias. Unnecessary impurities in the oil such as solid matter and food residues were removed using vacuum filtration.

2.2. Prior preparation

The traces of water present in the oil are removed before transesterification process by initial heating. The WCO is boiled for 20 min to ensure the minimal presence of water in the oil and to use it for further process.

2.3. FFA neutralization

Soap content is removed in the WCO transesterification process and correct amount of catalyst has to be added. Various titrations are performed to determine the amount of catalyst. The pH of the sample is maintained between 8 and 9 on pH scale using pH paper. Solution A containing 1 gram KOH was prepared with 10 ml of water. Another solution B containing 10 ml of iso-propyl alcohol is prepared with 1 ml of WCO. Then to get pH between 8 and 9 equivalents of KOH have to be determined which will neutralize FFA in the oil. This is carried out using drop-wise addition of solution A into solution B.

2.4. Transesterification of WCO using alkali

An alkali catalysis is required for transesterification process due to the presence of FFA in WCO. The WCO was heated up to 60 °C in flat bottom flask in order to prevent evaporation of methanol from the solution. The amount of KOH required (in grams) to be poured into reaction vessel, is obtained by adding FFA neutralization to a standard KOH solution.

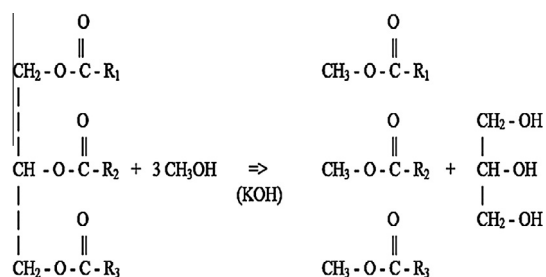

Figure 1 Transesterification reaction.

Solution C is prepared with this KOH weight in 200 ml water. Then, 1 l of filtered WCO is poured into the reaction vessel and heated with continuous stirring using a magnetic stirrer. When the temperature reaches 60 °C, 120 ml of solution C is poured into the reaction vessel and constant temperature is maintained for one hour. The entire solution is put in separating funnel for six hours to retrieve glycerol and WCO methyl ester layerwise. Recovered methyl ester is again subjected to the same procedure with 80 ml of solution C to remove traces of glycerol in order to achieve rich quality of biodiesel (WCME). Different blends of biodiesel (WCME20, WCME40, WCME80 and WCME100) are prepared for conducting experiments on CI engine to investigate its performance and emission characteristics. The fuel properties of blends along with petroleum diesel are listed in Table 1.

3. Experimental setup

In the present study, a constant speed, single cylinder, 4-stroke, air cooled DI diesel engine designed for agricultural purpose was used to test the fuels. The schematic arrangement of the experimental setup is shown in Fig. 2. The engine is coupled to an air cooled eddy current dynamometer. Using a load cell the engine torque was measured. Load on

the engine is varied with the help of a digital controller provided with the dynamometer. Fuel flow rate was measured using standard burette apparatus. Exhaust gas temperature was measured using K-type thermocouple. The exhaust gas emissions such as CO, HC, NO_x and fuel–air equivalence ratio were measured using a AVL digas 444 exhaust gas analyzer. The smoke opacity was measured by AVL 437C smoke meter. Table 2 shows the specifications of the engine. AVL pressure transducer GH14D/AH01 along with AVL INDIMICRA 1602-T10602A crank angle encoder was used for combustion analysis. The experiments are carried out with fixed injection timing of 23° bTDC at an injection pressure of 200 bar. The engine performance parameters such as brake thermal efficiency, engine out emissions, smoke opacity are recorded during the test. Engine was run at 1500 rpm and load was varied from no load to maximum load in 5 steps.

4. Results and discussions

4.1. Performance analysis

Various engine performance characteristics such as BTE, SFC, SEC and engine out emissions such as CO, UBHC, NO_x and

Table 1 Fuel properties.

S. no	Fuel	Kinematic vat 40 °C (Cst)	Flash point (°C)	Specific gravity	Calorific value kJ/kg
1	WCME20	5.2	65	0.860	42900
2	WCME40	5.4	78	0.865	41700
3	WCME80	5.7	80	0.875	40200
4	WCME100	6.1	94	0.900	39600
5	Diesel	4.2	50	0.840	44500

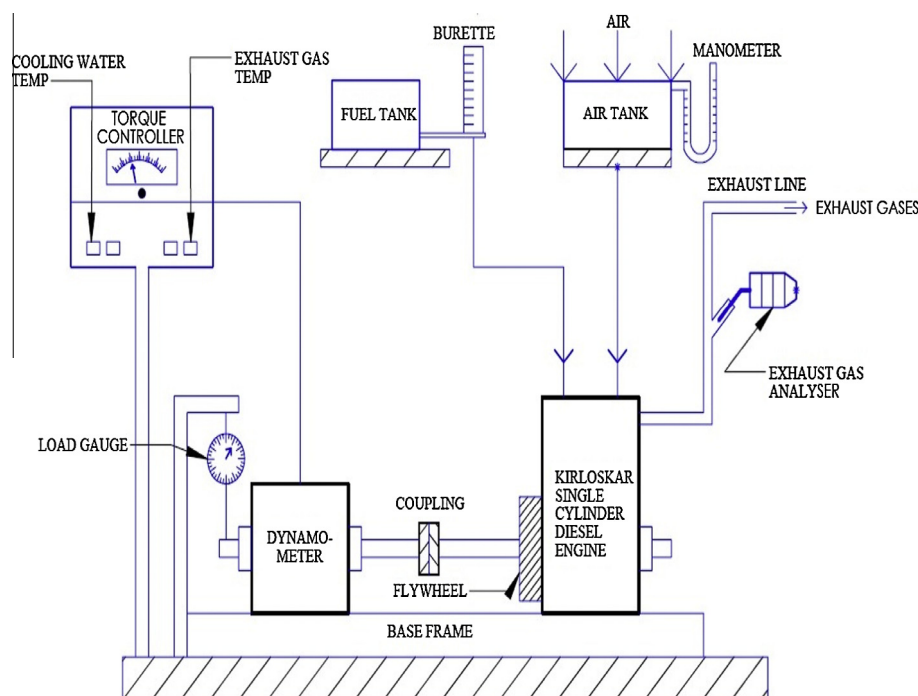

Figure 2 Schematic diagram of experimental setup.

Table 2 Engine specifications.

Type of engine	Four stroke, vertical air cooled diesel engine
Number of cylinders	Single
Bore/stroke	87.5/110
Compression ratio	17.5:1
Rated power	4.4 kW
Rated speed	1500 rpm
Injection timing	23°
Injection pressure	200 bar

smoke were analyzed for all blends of biodiesel along with fuels with petroleum diesel at different engine loads.

4.1.1. Specific fuel consumption (SFC)

The specific fuel consumption of various biodiesel blends and petroleum diesel is shown in Fig. 3. It is observed that SFC is higher for all WCME and its blends than diesel under various loading conditions. SFC is 0.351 kg/kW h for WCME100 and is 0.275 kg/kW h for diesel fuel. This is due to high viscosity, density and lower heating value of biodiesel. Specific fuel consumption is not a rational parameter to compare the performance of fuels having different calorific values. A more relevant parameter to compare engine parameter is specific energy consumption.

4.1.2. Specific Energy Consumption (SEC)

Fig. 4 shows the variation of SEC with respect to brake power for various WCME blends and petroleum diesel. When fuels with different heating value are tested, it is better to compare the specific energy consumption instead of specific fuel consumption. It is observed that, as the load increases, SEC of all fuels decreases. At full load condition, the difference in SEC of all biodiesels (WCME20, WCME40, WCME80 and WCME100) and diesel was found to be marginal. This may be attributed to the combined effect of lower heating value, higher density and viscosity of WCME.

4.1.3. Brake Thermal Efficiency

Brake Thermal Efficiency (BTE) is the ratio of brake power to the energy released during the combustion process. Fig. 5 shows the variations of brake thermal efficiency of biodiesel and its blends with respect to diesel fuel. It was found that BTE of WCME and its blends is slightly lower than that of

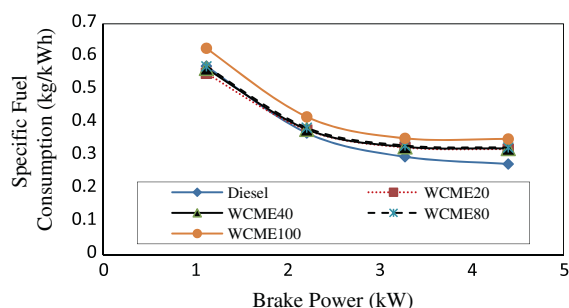

Figure 3 Variation of brake specific fuel consumption with brake power.

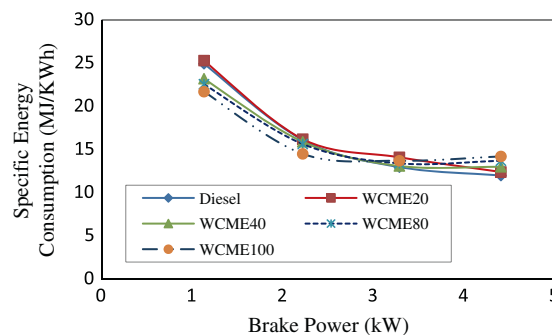

Figure 4 Variation of specific energy consumption with brake power.

diesel fuel, the maximum BTE of diesel fuel is 30% and those of WCME100 is 26%. This is due to WCME's lower heating value, higher density and increased viscosity which leads to poor atomization and fuel vapourization. Similar results were also reported in [17].

4.2. Emission characteristics

4.2.1. Unburned hydrocarbon emission

The unburned hydrocarbon emission trends for all biodiesel blends and diesel are shown in Fig. 6. It is shown that UBHC emissions decrease with increasing WCME percentage in the blend. It is also observed that UBHC emission increases as the load of the engine was increasing with diesel and blends of WCME as the result of increase in fuel consumption at high engine loads. A 57% reduction of UBHC in the case of WCME100 as compared to diesel indicates better combustion of WCME. WCO biodiesel involves high oxygen content, which leads to more complete combustion [18].

4.2.2. Carbon monoxide emission

Fig. 7 gives the comparison of the carbon monoxide (CO) emission of biodiesel and its blends with conventional diesel. CO is one of the intermediate compounds formed during the intermediate combustion stage of hydrocarbon fuels. CO formation depends on air fuel equivalence ratio, fuel type, combustion chamber design, starting of injection timing, injection pressure and speed. Experimental results reveal that CO concentration of biodiesel and its blends is 59%, 38%, 35% and 31% lesser for WCME20, WCME40, WCME80 and WCME100, respectively, when compared to diesel fuels operation. The results for the CO emissions are in-line with most of the literature [17–19]. This is due to the oxygen content in biodiesel which allows more carbon molecules to oxidize when compared with diesel fuel.

4.2.3. Oxides of Nitrogen Emission

The variation of Oxides of Nitrogen (NO_x) concentration with load for biodiesel blends and diesel is shown in Fig. 8. The formation of NO_x in the cylinder is affected by oxygen content, combustion flame temperature and reaction time. NO_x formation of all biodiesel and blends is slightly higher than that of diesel fuel and NO_x content of WCME100 is 18.33% higher than conventional diesel fuel under full load condition. It is also observed that as load increases, the NO_x formation

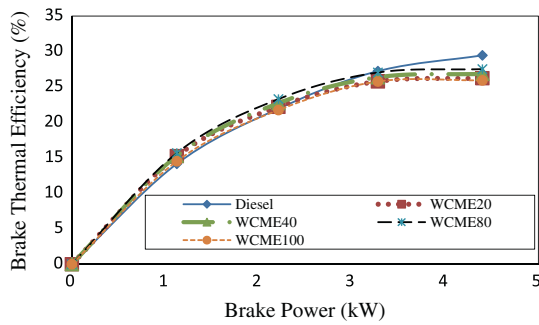

Figure 5 Comparison of brake thermal efficiency with brake power.

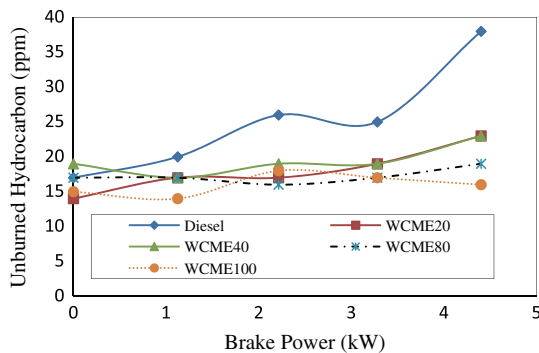

Figure 6 Variation of UBHC emission with brake power for various blends and diesel.

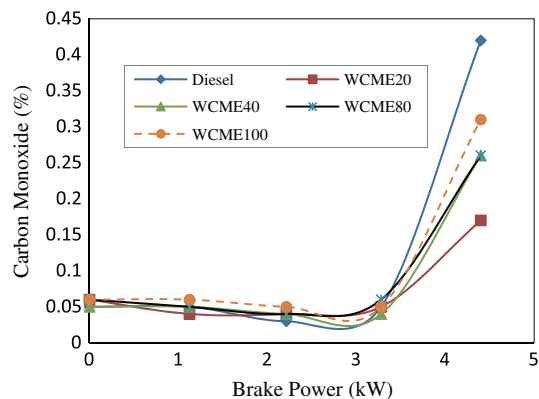

Figure 7 Variation of CO emission with brake power for various biodiesel blends and diesel.

increases and attains maximum value at maximum load. This is due to higher temperature of combustion and the presence of oxygen with biodiesel cause higher NO_x emission. The NO_x obtained in this study follows the trends as reported by Nabi et al. [20].

4.2.4. Smoke opacity

The smoke opacity of all the fuels used in this study is shown in Fig. 9. From the figure it can be seen that the smoke content of biodiesel and its blends are 24% higher than that of diesel fuel at low and middle engine loads. This is due to high

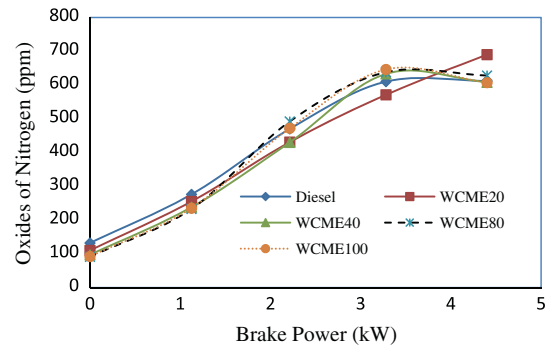

Figure 8 Comparison of NO_x emission with brake power.

viscosity of biodiesel, which results in poor atomization and locally rich mixtures at part load operations. But, at high engine load, smoke opacity of all biodiesel blends is lower than diesel fuel. It is because of low C/H ratio and oxygen content of biodiesel compared to conventional diesel fuel [21].

4.3. Combustion characteristics

Combustion characteristics of WCME biodiesel can be explained by cylinder pressure, peak pressure and heat release rate. Fig. 10 shows the variation of cylinder gas pressure with crank angle for all blends of WCME and with diesel fuel at 100% full load. Cylinder pressure characterizes the ability of the fuel to mix well with air and burn. The pressure waves in the cylinder during combustion indicate engine noise. All biodiesel blends of WCME20, WCME40, WCME80 and WCME100 follow similar cylinder gas pressure trends to that of diesel fuel under full load condition. The peak cylinder pressures are 6.70 MPa, 6.74 Mpa, 6.79 Mpa, 6.8 Mpa and 6.39 Mpa for WCME20, WCME40, WCME80, WCME100 with diesel fuel respectively at full load conditions. It can be observed from the Fig. 10 that peak cylinder gas pressure occurred within the range of 7–10° CA ATDC for all biodiesel and with diesel fuel. Similar results observed by Rao et al. [19]. The comparison of heat release rate variations for biodiesel and its blends with diesel fuel at 100% full load is shown in Fig. 11. Heat release pattern of a fuel is helpful to get some valuable information about the combustion process in an

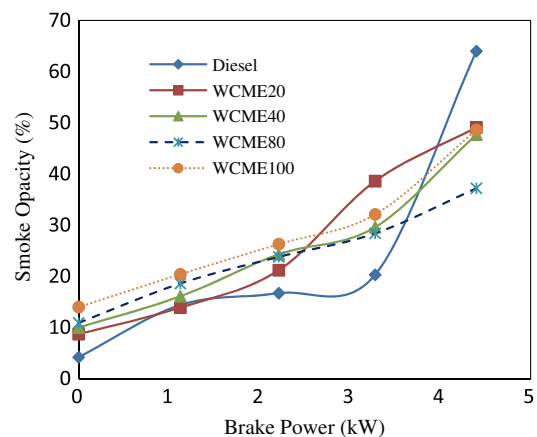

Figure 9 Variation of smoke opacity with brake power.

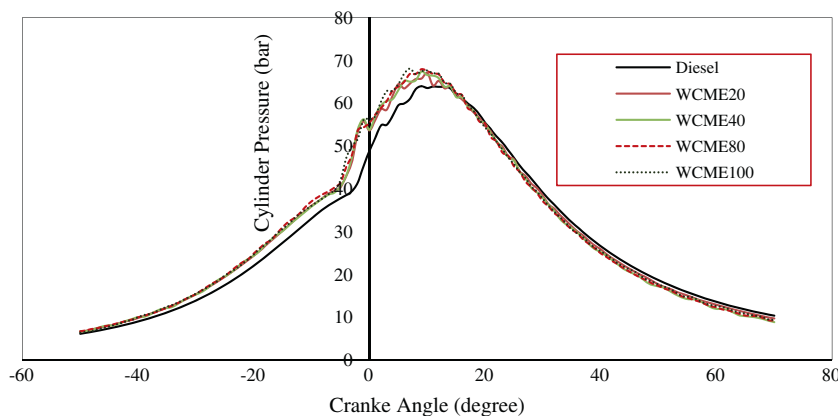

Figure 10 Comparison of cylinder pressure with crank angle at 100% load.

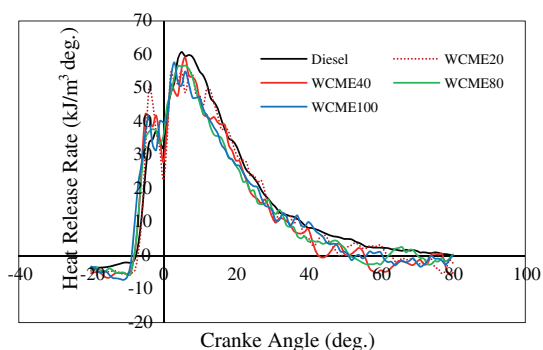

Figure 11 Comparison of heat release rate at 100% load for biodiesel and its blends with diesel.

engine such as start of combustion timing and heat release rate at different crank angles. It can be observed that WCME and its blends experience similar combustion stages as diesel fuel at full load condition. But the premixed combustion rate of all biodiesel and its blends are slightly higher than diesel fuel and main combustion rate of diesel fuel is marginally higher than all biodiesel and its blends. This is due to the accumulation of large amount of diesel fuel in the combustion chamber at the time of premixed combustion phase, which resulted in higher heat release rate at full load condition [22].

5. Conclusion

In the present investigation, the performance, emission and combustion characteristics of a direct injection compression ignition engine fueled with waste cooking oil methyl esters and their blends have been discussed and compared with diesel fuel. Results of the present work are summarized as follows:

1. The diesel engine can perform satisfactorily on biodiesel and its blends with the diesel fuel without any engine modifications.
2. The SEC increases with change in percentage of biodiesel in the blends due to the lower heating value of biodiesel.
3. It is also observed that there is significant reduction in CO, UBHC and smoke emissions for biodiesel and its blends compared to diesel fuel. However, NO_x emission of WCME biodiesel is marginally higher than petroleum diesel.

It can be concluded that WCO biodiesel could replace the diesel in order to help in controlling air pollution, encouraging the collection and recycling of waste cooking oil to produce biodiesel and reduce the dependency on fossil fuel resources to some extent without sacrificing engine performance.

References

- [1] A.K. Agarwal, Biofuels (alcohols and biodiesel) applications as fuels for internal combustion engines, *Progr. Energy Combust. Sci.* 33 (2007) 231–277.
- [2] T. Krawczyk, Biodiesel – alternative fuel makes inroads but hurdle remains, *INFORM* 7 (1996), 801–815.
- [3] S. Sinha, A.K. Agarwal, Performance Evaluation of Biodiesel (Rice Bran Oil Methyl Ester) Fuelled Transport Diesel Engine, SAE 2005-01-1730, 2005.
- [4] B. Freedman, E.H. Pryde, T.H. Mounts, Variables affecting the yields of fatty esters from transesterified vegetable oils, *JACOS* 61 (1984) 1638–1643.
- [5] Y. Ali, M.A. Hanna, Alternative diesel fuels from vegetable oils, *Bioresour. Technol.* 50 (1994) 153–165.
- [6] R. Altin, S. Cetinkaya, H.S. Yucsu, Potential of using vegetable oil fuels as fuel for diesel engines, *Energy Conversion Manage.* 42 (2001) 529–538.
- [7] K.W. Scholl, S.C. Sorenson, Combustion of Soybean Oil Methyl Ester in a Direct Injection Diesel Engine, SAE 930934, 1993.
- [8] A. Srivastava, R. Prasad, Triglycerides based diesel fuels, *Renew. Sustainable Energy Rev.* 4 (2000) 111–133.
- [9] S. Kalligeros, F. Zannikos, S. Stournas, E. Lois, G. Anastopoulos, C. Teas, F. Sakellariopoulos, An investigation of using biodiesel/marine diesel blends on the performance of a stationary diesel engine, *Biomass Bioenergy* (2003) 141–149.
- [10] L. Yuceer, Performance and emission study of biodiesel from leather industry pre-fleshings, *Waste Manage.* 27 (2007) 1897–1901.
- [11] The effects of exhaust gas recirculation on exhaust emission and combustion characteristics of a CI engine operated on Diesel and WCO Biodiesel, *Int. J. Eng. Res. Dev.*
- [12] S.A. Basha, K.R. Gopal, S. Jebaraj, A review on biodiesel production, combustion emissions and performance, *Renew. Sustainable Energy Rev.* 13 (2009) 1628–1634.
- [13] M.G. Kulkarni, A.K. Dalai, Waste cooking oils, an economical source of biodiesel: a review, *Ind. Eng. Chem. Res.* 45 (2006) 2901–2913.
- [14] A. Bijalwan, C.M. Sharma, V.K. Kediya, Bio-diesel revolution, *Sci. Reporter* (2006) 14–17.

- [15] B. Mazumdar, A.K. Agarwal, Performance, Emission and Combustion Characteristics of Biodiesel (Waste Cooking Oil Methyl Ester) Fueled IDI Engine, SAE 2008-01-1384, 2008.
- [16] K. Muralidharan, D. Vasudevan, K.N. Sheeba, Performance, emission and combustion characteristics of biodiesel fuelled variable compression ratio engine, *Energy* 36 (2011) 5385–5393.
- [17] A.N. Ozsezen, M. Canakci, A. Turkcan, C. Sayin, Performance and combustion characteristics of a DI diesel engine fueled with waste palm oil and canola oil methyl esters, *Fuel* 88 (2009) 629–636.
- [18] C.V. Sudhir, N.Y. Sharma, P. Mohanan, Potential of waste cooking oils as biodiesel feedstock, *Emirates J. Eng. Res.* 12 (2007) 69–75.
- [19] G.L.N. Rao, S. Sampath, K. Rajagopal, Experimental studies on the combustion and emission characteristics of a diesel engine fueled with used cooking oil methyl ester and its diesel blends, *Int. J. Eng. Appl. Sci.* 4 (2008) 64–70.
- [20] N. Nabi, M. Rahman, Akhter Biodiesel from cotton seed oil and its effect on engine performance and exhaust emissions, *Appl. Therm. Eng.* 87 (2009) 714–722.
- [21] Puhan Sukumar, N. Saravanan, G. Nagarajan, N. Vedaraman, Effect of biodiesel unsaturated fatty acid on combustion characteristics of a DI compression ignition engine, *Biomass Bioenergy* 34 (2010) 1079–1088.
- [22] P.K. Sahoo, L.M. Das, Combustion analysis of Jatropha, Karanja and Polanga based biodiesel as fuel in a diesel engine, *Fuel* 88 (2009) 994–999.