

Available online at www.sciencedirect.com**ScienceDirect**

Procedia Engineering 131 (2015) 861 – 870

**Procedia
Engineering**www.elsevier.com/locate/procedia

World Conference: TRIZ FUTURE, TF 2011-2014

TRIZ methodology adapted to hybrid powertrains performances evaluation

Francis Roy^{a,b}, Claude Gazo^c, Florence Ossart^b, Claude Marchand^b^aPSA Peugeot Citroën, La Garenne-Colombes, France^bLaboratoire de Génie Electrique de Paris (LGEP), CNRS UMR8507, SUPELEC, UPMC, Univ. Paris-Sud, Plateau de Moulon 91192 Gif sur Yvette, France^cLaboratoire Conception de Produits & Innovation (LCPI), Arts et Métiers, ParisTech, 151, Boulevard de l'Hôpital, 75013 PARIS

Abstract

On-going oil stock depletion and growing environmental concerns lead automakers to develop more efficient powertrains. Today the most promising way forward consists in research on hybrid systems. The present study uses TRIZ methodology to help identify the best hybridization architecture and powertrain design, in order to reduce CO₂ emissions. This optimization problem is constrained with cost, mass and complexity targets. It is applied to B segment hybrid electric vehicle (HEV) with no connection to the grid to recharge the battery.

A specific procedure based on TRIZ principles has been established and rolled out after a first mathematical analysis of different current hybridization architectures (series, parallel and combined). The adapted TRIZ methodology is mainly built on the principles of Ideal Final Result and on networks of contradictions. It is used to compare the performances of the different architectures, identify the main technological barriers for more CO₂ savings, and propose a roadmap to overcome them.

© 2015 The Authors. Published by Elsevier Ltd. This is an open access article under the CC BY-NC-ND license

(<http://creativecommons.org/licenses/by-nc-nd/4.0/>).

Peer-review under responsibility of the Scientific Committee of TFC 2011, TFC 2012, TFC 2013 and TFC 2014 – GIC

Keywords: HEV, TRIZ, Hybrid powertrain, series topology, parallel topology, combined topology, powertrain performance;

1. Introduction

In the current context of increasing demand for personal transportation, on-going oil stock depletion and growing environmental concerns, profound technological mutations are needed in the design of passenger cars. For more than one century, automotive industry has been dominated by internal combustion engine (ICE) based powertrains: the low efficiency and the irreversibility of this kind of motor are balanced by the very high energy density of oil and its easy on-board storage. Efficiency gains are still expected for ICE, but further improvements can be achieved by coupling fossil energy with a complementary on-board energy. Today, all automakers are

focusing their research and development activities on these hybrid systems to offer more efficient cars with low carbon footprint at affordable prices.

The present paper concerns a TRIZ study to compare different hybrid-electric powertrains topologies (series, parallel and combined), and to identify possible improvements and guideline for the design of low CO₂ emission hybrid electrical vehicles. The TRIZ theory has been chosen, as it was necessary to find without preconceived ideas the key factor and the best guideline for powertrain improvement [1,2].

The paper is divided into three parts:

- Presentation of the powertrain systems and methodology
- Mathematical modeling of the considered hybrid powertrains using optimal control strategies
- Comparison and critical analysis of the performances of the different powertrains using TRIZ principles (Ideal Final Result and networks of contradictions [3,4])

2. Perimeter of the study and methodology

The study focuses on the electric hybridization of a B segment vehicle (Peugeot 208), with no Plug In function (no possible recharge of the battery from the grid). The technical system corresponds to the whole powertrain, from the gasoline tank to the wheels. It includes a fossil source of power (fuel and ICE), at least one electrical machine, an energy storage system (battery) and coupling devices (gears, clutch,...). Three classical powertrain topologies, depicted on figure 1, are considered.

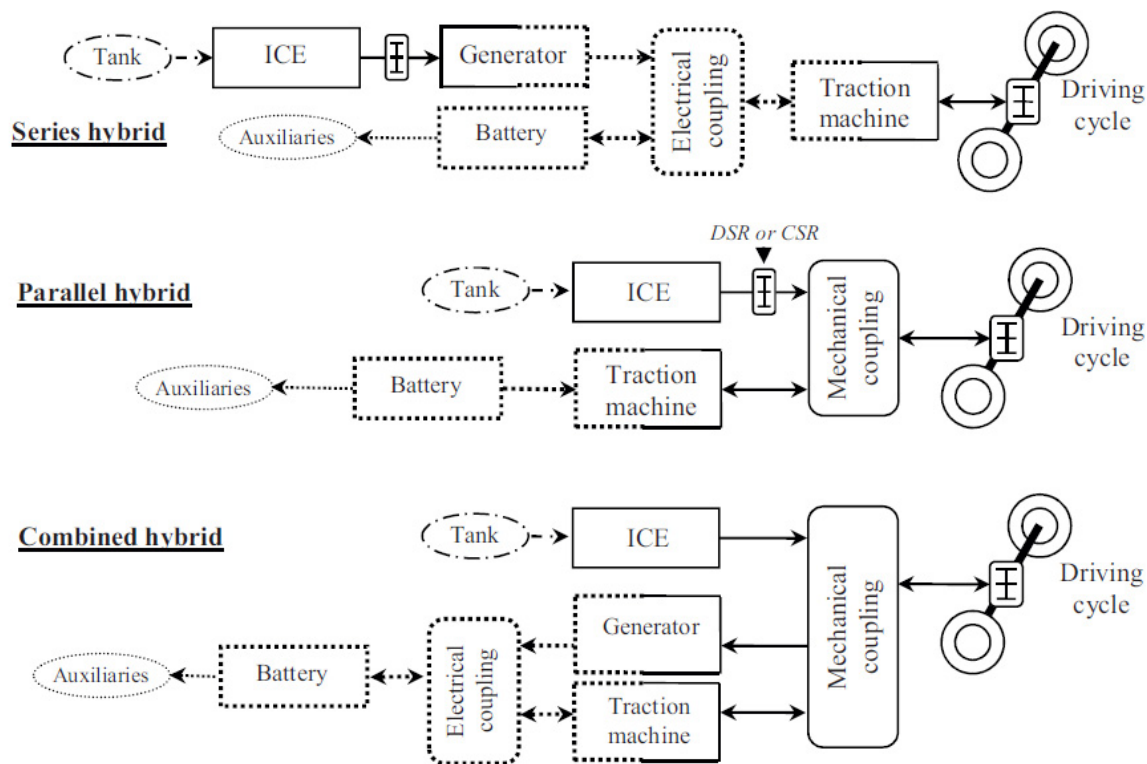

Figure 1: Series, parallel and combined hybrid powertrain architectures - Solid lines are for mechanical power flux, and dashed ones for electrical power flux.

The series architecture is intended to extend the range of a purely electrical vehicle by supplying the electric power by an engine-driven generator. The parallel architecture can be seen as an ICE one, improved by additional electric power. In both cases, a battery is needed for temporary storage and optimized management of the electrical energy. The combined architecture mixes both features.

The same power components are used in all the powertrains studied. The ICE is a 1.0-liter 3-cylinder in-line gasoline motor, whose efficiency map is shown on Figure 2. The maximum efficiency is 34%, and is obtained for an optimal power, denoted $P_{ICE\ opt}$, of 26 kW (72 Nm – 366 rad/s).

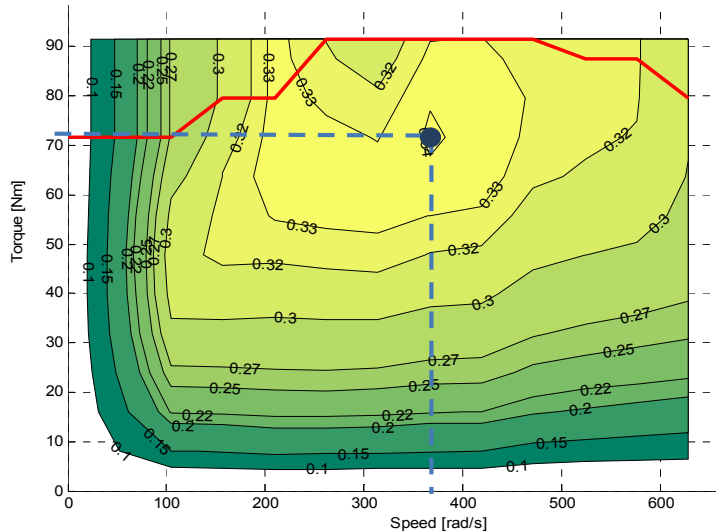

Figure 2: ICE map – location of the maximum ICE efficiency (blue point)

The electrical machines are 50 kW motors, also characterized by their efficiency maps. The parallel architecture has been studied with two different mechanical coupling principles between the ICE and the wheels. These devices are needed to accommodate the rotational speed of the ICE to the wheels one, according to the power to provide at a given time. The discrete speed ratio system (DSR) corresponds to a classical gear box, with 5 fixed speed ratio, whereas the continuous speed ratio system (CSR) corresponds to an ideal one, with an infinite number of speed ratio. A 97% efficiency is assumed for both systems. For the combined hybridization, the mechanical coupling corresponds to a planetary gear, which uses an electrical generator to produce a continuous speed ratio.

The power demand at the wheels is a function of time. To maximize the global powertrain efficiency when producing power traction, an energy balance must be found between the thermal branch and the electric one.

In order to test the different architectures, several driving cycles representative of customer use have been considered (Urban, Road and Highway INRETS cycles [5,6]). These cycles are characterized by their mean speed. For each architecture, the lowest gasoline consumption is calculated using an optimal control strategy and dynamic programming.

The study is based on TRIZ theory [7,8], taking from its main creativity function to roll out a critical analysis of these hybrid powertrains. The roadmap is mainly built on the Ideal Final Result and networks of contradictions (Technical and Physical).

3. Hybrid powertrains modeling using optimal control strategies

3.1. Mathematical theory

For a maximum benefit of hybrid architecture for CO₂ emission saving, it is necessary to develop efficient control systems. At each step of time, the Smart Energy Management system has to determine the best control or power split ratio between the electric and thermal energies to achieve the optimal global efficiency.

The following optimization problem (1) has to be solved: find $u(t)$ in the space of possible control functions U , so that the total consumption $j(u)$ over a given cycle is minimum, and that the constraints on the battery state of charge (SOC) are fulfilled.

$$\begin{cases} u_{optimal}(t) = argmin_{u \in U} J[u(t)] \\ SOC_{min} \leq SOC(t) \leq SOC_{max} \\ SOC(t_{initial}) = SOC(t_{final}) \end{cases}$$

Control systems are usually based on heuristic approaches, which are intuitive and pragmatic, but whose reliability to find the lowest consumption is limited. For a significant comparison of the different hybrid powertrains, optimal control strategies based on variational calculations will be preferred. Specific optimization tools have been developed, such as the Maximum Principle of Pontriaguine or the Dynamic Programming of Bellman [9,10,11]. Due to easy integration of the constraints in the algorithm and efficient computation, Dynamic Programming has been deemed the best way to solve the optimization problem of consumption minimization.

The control function $u_{optimal}(t)$ and all resulting quantities are obtained: electric power, intensity and SOC of the battery, and of course the total fuel consumption or CO₂ saving.

1.1. Results

Figure 3 presents the CO₂ saving and the mean ICE efficiency as a function of the mean speed of the vehicle, for different driving cycles. The reference system corresponds to a conventional ICE vehicle with a classical gear box (DSR).

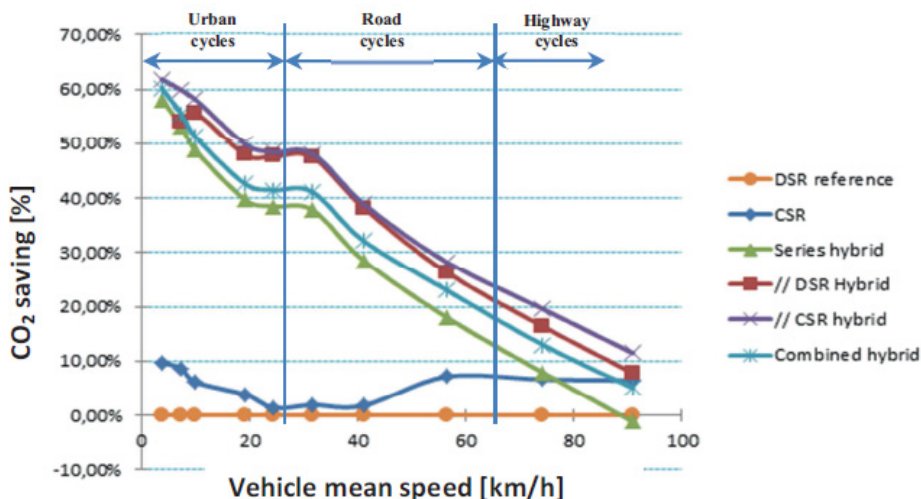

Figure 3 : CO₂ saving performances of the studied powertrains for different INRETS driving cycles

The CSR powertrain configuration corresponds to the same conventional vehicle, with a continuous speed ratio. Four hybrid powertrains are compared: series topology, parallel topology with a DSR or a CSR, combined topology.

All hybridization topologies show the same trend: the lowest the speed, the highest the CO₂ saving. The highest CO₂ saving is achieved by the parallel CSR powertrain. The parallel DSR powertrain is slightly under, because the ICE speed cannot be as precisely adapted to the wheel speed, especially at very low speed and during the starting phase, where a clutch is necessary. The combined hybridization produces the desired continuous speed ratio, but with efficiency limited by the losses in the electrical devices, resulting in a global gain about 7 points under the parallel CSR powertrain. The series hybridization is the less effective one, with global gain 10 points under the parallel CSR hybrid. A remarkable point is that for urban cycles with congested traffic (very low mean speed), all hybridizations topologies seem to converge towards the same level of CO₂ saving.

It is also interesting to look at the ICE efficiency (see figure 4). The series hybridization makes it possible to operate the ICE at its best efficiency during the whole cycle, but this gain requires the use of electrical devices with losses higher than for the parallel topology. The simulation shows that the global gain is not so good.

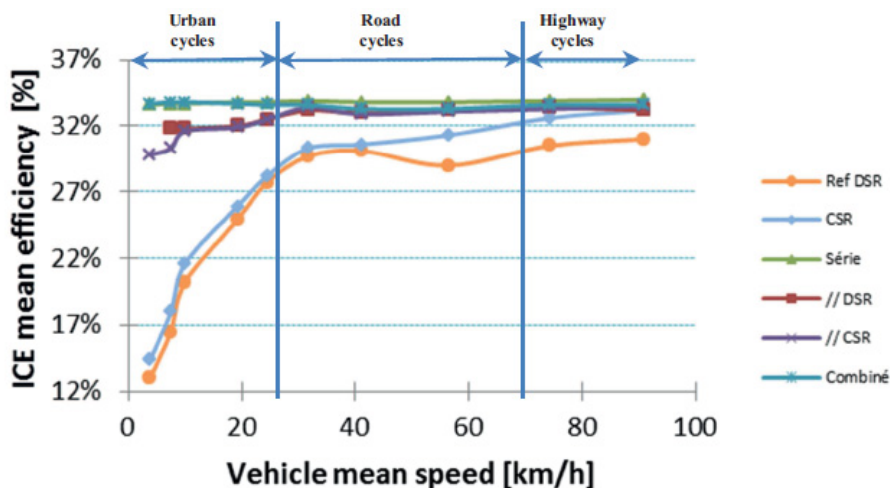

Figure 4 : ICE mean efficiency of the studied powertrains for different INRETS driving cycles

These results show that the parallel CSR topology seems to be the best one, provided that the CSR coupling device has a very good efficiency. Hence, a detailed analysis must be completed to identify the best way for powertrain improvement, and TRIZ theory will be used to focus our thinking.

4. Comparison of hybrid powertrain using TRIZ tools

1.2. Comparison using Ideal Final Result (IFR)

1.2.1. Definition

System ideality can be defined by the following formula.

$$D = \frac{\sum F_u}{\sum F_c + \sum F_h}$$

where :

D is the ideality degree,

ΣF_u is the sum of the benefits of the useful functions

ΣF_c is the sum of the costs which are generated by the system

ΣF_h is the total spending due to the harmful functions induced by the system.

In the case of a hybrid powertrain, the useful functions are: to operate the ICE working at its best efficiency and to recover the kinetic energy of the vehicle. The cost and harmful functions can be associated to the electrical and coupling devices and include power losses, mass, volume and production cost.

The IFR can be expressed by the following expression. It is used for the critical analysis of common hybridization.

$$IFR : D = \frac{\text{Gasoline energy efficiency for vehicle traction And Kinetic energy recovery}}{\Sigma \text{losses And } \Sigma \text{mass And } \Sigma \text{volumes And } \Sigma \text{cost}}$$

In the next section, the benefits and costs associated to the different powertrains under study are analyzed.

1.1.1. Powertrain evaluation using IFR approach

Series hybridization:

ΣF_u : As there is no mechanical coupling between the ICE and the wheels, the thermal engine can be operated at its best efficiency to produce electrical energy via the generator. This energy either supplies the traction machine, or the battery, which constitutes an energy buffer.

The kinetic energy of the vehicle is recovered by the traction machine and stored in the battery for future use.

$\Sigma F_c + \Sigma F_h$: The series topology results in successive energy conversions, as described hereunder, producing losses in the battery, the generator and the traction machine.

Chemical Energy \rightsquigarrow Thermal Energy \rightsquigarrow Mechanical Energy \rightsquigarrow Electric Energy \rightsquigarrow Mechanical Energy.

This architecture requires both electrical machines to be sized according to the maximum power to be provided by the powertrain. There is no possibility of power addition (ICE + electric machine).

Simulations show that this architecture leads to a high battery load, which produces Joule losses.

Parallel hybridization - DSR:

ΣF_u : The ICE and the wheels are mechanically coupled, with 5 possible speed ratio. A proper speed ratio allows to operate the ICE as close as possible to its best efficiency. This direct coupling limits the number of energy conversions for the main part of the energy flux, which directly flows from the ICE to the wheels.

Chemical Energy \rightsquigarrow Thermal Energy \rightsquigarrow Mechanical Energy

The electric machine allows for energy recovering during braking phases.

$\Sigma F_c + \Sigma F_h$: The part of the energy flux which is derived through the battery to adapt the ICE efficiency is subjected to energy conversion and electrical losses.

Figure 4 shows that above 30 km/h (average speed), the ICE efficiency is close to its maximum value, whereas below 30 km/h, the ICE efficiency is not as good. To obtain the best efficiency, the ICE must be operated at a rather high power (around 20 kW). If the wheel power is lower than this optimal value, the excess of energy is derived through the electrical system and stored in the battery for later use, but this energy conversion has a cost.

The Smart Energy Management procedure finds the optimal split ratio and ICE working point according to the thermal and electrical efficiencies. During starting phases, the optimal control strategy leads to an electric start.

Parallel hybridization - CSR:

ΣF_u : As for the previous hybridization, there is a mechanical coupling between the ICE and the wheels, but the speed ratio can take any value. Hence, the ICE working point can be more precisely adapted. Energy recovery is unchanged.

$\Sigma F_c + \Sigma F_h$: The part of the energy flux which is derived in the electrical system is subjected to electrical losses.

Simulations show that the mean ICE efficiency is not improved by using the CSR, but the global efficiency of the system is better because the electrical cost of the ICE optimization is lower. It should be noted that the simulations assume a CSR coupling device with a 97% efficiency, which is not available at the time being.

Starting phases can be provided in a purely electric mode or by the ICE.

Combined hybridization:

ΣF_u : This architecture allows to maximize ICE efficiency whatever the mean speed. At low speed, the operating conditions are close to the series hybrid ones. At higher speed and for high power demand, the optimal powertrain efficiency is achieved by splitting the power between the electric branch and the mechanical one to produce a CSR effect.

During deceleration phase, as for the other hybridizations, the electric machine allows energy recovery.

$\Sigma F_c + \Sigma F_h$: If the operating principle is equivalent to the previous hybrid topology, the efficiency of the system is lower because of losses in the generator. This architecture requires two electrical machines, which increases the complexity and the cost of the system.

1.2.2. IFR synthesis

The critical analysis using the Ideal Final Result on the different hybrid powertrain allows identifying different behaviors, depending on the power demand:

- Starting phase:
 - A purely electric starting avoids problems of ICE speed limit
 - A CSR subsystem can be used to optimize ICE operating point
- Acceleration and constant speed phases:
 - A direct mechanical coupling between the ICE and the wheels is recommended

The operating point of the ICE can be optimized by adapting speed ratio or by using the electric machine

- Braking phase:
 - To maximize energy recovery during braking phases, an electrical machine must be linked directly to the wheels, so as to maximize the efficiency.

When the power at the wheel is zero, the ICE and the electric machine can be disconnected from the wheel (vehicle stop and coasting mode). The ICE is stopped and a zero torque is applied to the electric machine.

Table 1: IFR principles for an ideal hybrid powertrain

	Traction $P_{\text{demand}} > 0$		Vehicle stop and coasting $P_{\text{demand}} = 0$	Regenerative braking $P_{\text{demand}} < 0$
IFR principles	When P_{demand} is close to $P_{\text{ICE, opt}}$ the ICE should be directly coupled to the wheels, with no use of electric energy.	Otherwise, the electric energy is used to optimize the ICE working point and the global efficiency.	The ICE and the electric machine are stopped. The battery is used to supply auxiliaries' power.	The ICE is stopped The electric machine should be linked directly to the wheels.
Potential powertrain architecture	Parallel CSR and DSR	Parallel CSR and DSR Combined Series hybrid	Parallel CSR and DSR Combined Series hybrid	Parallel CSR and DSR Combined Series hybrid

Table 1 summarizes the IFR principles for an ideal powertrain architecture and indicates which studied powertrain can achieve these principles.

1.3. Comparison using Contradiction network

1.3.1. Introduction

The system leads to identify several Technical and Physical Contradictions (TC and PC), on:

- The ICE power and efficiency,
- The ICE speed
- The battery capacity

1.3.2. Contradictions on the power and ICE efficiency

TC : Increasing the efficiency of the thermal branch produces losses in the electric branch

PC : The ICE power must correspond to the maximum efficiency to maximize the thermal branch efficiency, and equal to the power demand to limit electric branch losses.

Series and combined hybridization can make the ICE work at its best efficiency, but the global efficiency is affected by losses in the electric branch. Parallel DSR hybridization, strongly constrained with wheel speed, cannot operate the ICE at its best efficiency at low speed. CSR hybridization appears as a good architecture to bring out a compromise situation to select the best ICE operating point (Torque - Speed) at a low electrical cost.

1.3.3. Contradictions on components rotation speed

TC: The highest ICE efficiency is obtained at a given fixed speed. This imposes a coupling device with a variable speed ratio between the ICE and the wheel, which increases the system complexity.

PC: The ICE speed must be a function of the wheel speed, and independent of the wheel speed to optimize ICE efficiency.

Parallel hybridization using DSR, which presents a mechanical coupling between ICE and the wheels, does not allow the ICE to run at its best efficiency point all the time. However, in the mean speed range 20 – 60 km/h, the global powertrain efficiency performs as well as the CSR hybridization.

At very low speed and to start the vehicle, the parallel hybridization using DSR requires a clutch to adapt the ICE speed to the vehicle speed. The other hybridization type, like parallel CSR and combined, does not require a clutch, as this function is integrated in the CSR subsystem.

During braking phases, the ICE should not be driven by the wheels in order to avoid friction and pumping losses. The ICE can be decoupled from the wheels by using an auxiliary subsystem such as a clutch, a freewheel, a dog clutch,...

1.3.4. Contradictions on battery capacity

TC: The battery must have a minimum capacity in order to insure purely electric starting and optimization of the ICE working point. By increasing the battery capacity, braking energy recovering is maximized, but its mass, volume and cost increase.

PC: The optimal battery capacity must be large enough to maximize energy recovery and small to minimize cost, volume and mass.

Figure 5 focuses on the CO₂ saving of the parallel CSR topology. It shows the part of the saving which is due to the braking energy recovery. At very low mean speed, the challenge is to optimize the ICE operating point, whereas at higher mean speed the optimization of energy recovery is crucial.

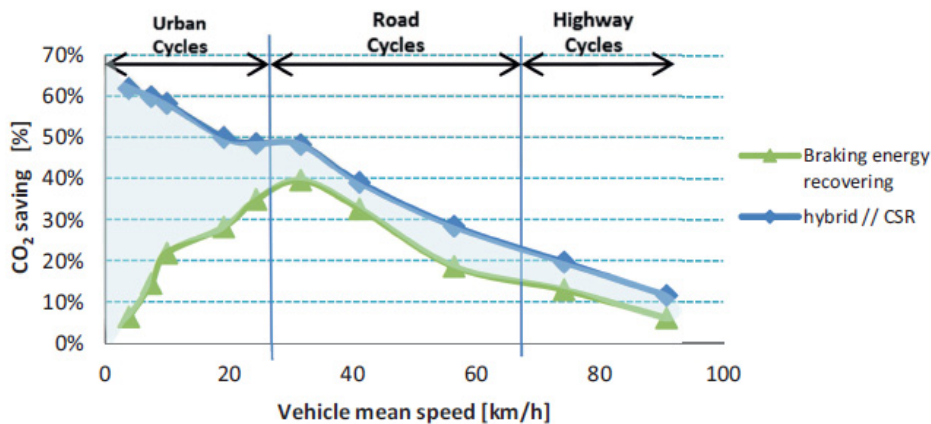

Figure 5: Energy recovery contribution to the global CO₂ saving for parallel CSR hybridization

1.1.1. Contradictions synthesis

These contradictions lead to consider two real life situations, each one having particular technical specifications:

- Urban customer use
- Road/Highway customer use

For urban operating conditions, the design should focus on optimizing the operating point of the ICE, while keeping low losses in the electric branch. As a consequence, close attention has to be paid to the electric machine design. For the starting phase, two solutions can be considered: the parallel CSR hybrid, or a purely electric starting, which can in addition provide substantial consumer benefit, such as silent, dynamic behavior, ..., and perhaps can give some design opportunity to simplify the powertrain.

For road and highway vehicle use, efforts should be put on the optimization of braking energy recovery. During braking, the ICE should be stopped and decoupled from the wheels to avoid friction and pumping losses.

5. Conclusion

Smart energy management, based on efficient mathematical optimization, provides a large number of results. TRIZ theory has been used in an original way to organize thinking on the comparison of powertrain hybridization and point out the key factors.

The present paper shows the interest of the proposed tools to identify technological advances and to guide the design of efficient hybrid powertrains. This study corresponds to the first part of a global approach from the state-of-the-art technology to the hybrid powertrain design for CO₂ saving. In the next step, TRIZ will be applied to the optimization of components design.

References

- [1] Tomiyama, T., Gu, P., Jin, Y., Lutters, D., Kind, C., & Kimura, F., 2009, "Design methodologies: Industrial and educational applications," *CIRP Annals - Manufacturing Technology*, vol. 58, no. 2, pp. 543-565
- [2] Durand J., Weit  PA, Gazo C., Lutz P., "Determination and evaluation of the possible links and sequences between triz and other design methods", International Conference On Engineering Design, ICED'07, 28 - 31 august 2007, Paris, France.
- [3] Cavallucci D. *Contribution a la conception de nouveaux syst mes m caniques par int gration m thodologique* [Ouvrage]. - Strasbourg: Th se doctorale, 1999.
- [4] Cavallucci D., Rousselot F. et Zanni C. *Procedures and Models for Organizing and Analysing Problems in Inventive Design* [Ouvrage]. - CIRP Design Conference, 2009.
- [5] Crauser J., Maurin M., and Joumard R., "Representative Kinematic Sequences for the Road Traffic in France," SAE Technical Paper 890875, 1989, doi:10.4271/890875.
- [6] Joumard R., Andr  M., Vidon R., Tassel P., Pruvost C., « Influence du cycle de conduite sur les  missions unitaires de polluants des voitures particuli res », Rapport n  LTE 9902 de D cembre 1999.
- [7] Altshuller G. *Creativity as an exact science : The Theory of the Solution of Inventive Problems* [Ouvrage]. - Amsterdam : Gordon & Breach, 1984.
- [8] Savransky S. D. *Engineering of Creativity: Introduction to TRIZ Methodology of Inventive Problem Solving* [Ouvrage]. - CRC Press, 2000.
- [9] Bellman RE. *Dynamic programming*. Princeton University Press, 1957
- [10] Culioli JC. *Introduction   l'Optimisation* [Ouvrage]. - Ellipse, 2012.
- [11] Sciarretta L. Guzzela A. *Vehicle Propulsion Systems - Introduction to modelling and optimization* [Ouvrage]. - Z rich : Springer, 2009.