



Available online at www.sciencedirect.com

ScienceDirect

Energy Procedia 75 (2015) 1758 – 1765

Energy

Procedia

The 7th International Conference on Applied Energy – ICAE2015

Model development of a blast furnace stove

Jonas Zetterholm^{a*}, Xiaoyan Ji^b, Bo Sundelin^c, Peter M. Martin^d, Chuan Wang^a

^aSwerea MEFOS, Process Integration Department, Box 812, 971 25 Luleå, Sweden

^bEnergy Science/Energy Engineering, Luleå university of technology, SE-97187, Luleå, Sweden

^cSSAB EMEA Oxelösund SE-613 80, Oxelösund, Sweden

^dSiemens VAI Metals Technologies, 501 Technology Drive, Canonsburg, PA 15317

Abstract

A large amount of energy is required in the production of steel where the preheating of blast in the hot blast stoves for iron-making is one of the most energy-intensive processes. To improve the energy efficiency it is necessary to investigate how to improve the hot blast stove operation.

In this work a mathematic model for evaluating the performance of the hot blast stove was developed using a finite difference approximation to represent the heat transfer inside the stove during operation. The developed model was calibrated by using the process data from the stove V26 at SSAB Oxelösund, Sweden. As a case study, the developed model was used to simulate the effect of a new concept of OxyFuel technique to hot blast stoves. The investigation shows that, by using the OxyFuel technique, it is possible to maintain the blast temperature while removing the usage of coke oven gas. Additionally, the hot blast temperature increases while the flue gas temperature decreases, which allows for an increase of the blast temperature, leading to improved energy efficiency for the hot stove system.

© 2015 The Authors. Published by Elsevier Ltd. This is an open access article under the CC BY-NC-ND license (<http://creativecommons.org/licenses/by-nc-nd/4.0/>).

Peer-review under responsibility of Applied Energy Innovation Institute

Keywords: blast furnace stove; flue gas; flame temperature; hot blast; heat transfer

1. Introduction

About one third of the world primary energy consumption is from the manufacturing industries. The iron and steel industry (ISI) is the second largest energy user and accounts for 20 % of the energy usage by the manufacturing industries [1]. Due to heavy reliance on fossil fuels as both energy carrier and

* Corresponding author. Tel.: +46 920 20 19 00; fax: +46 920 25 58 32.

E-mail address: jonas.zetterholm@swerea.se

reducing agent the ISI is the largest CO₂ emitter with nearly one third of the total CO₂ emissions in the industrial sector. This corresponds to about 4 – 5 % of the world total CO₂ emission [1].

The blast furnace – basic oxygen furnace (BF-BOF) process accounts for nearly 70 % of the world crude steel production [1]. Hot blast stoves are very important auxiliary equipment to the BF process, providing hot blast to the process. The function of the hot blast stove is to provide high-temperature blast to the BF at a constant flow, which provides thermal energy and reducing gas to the BF process through the combustion of coke and injected fuels in the tuyere level. Hot blast stoves work as counter-current regenerative heat exchangers, and they are often heated up by the process gases generated from the steelworks, such as BF gas and coke oven gas (COG). For an integrated steel plant, 10 – 20% of total energy is used in hot blast stoves for the hot blast production [2].

Stoves are operated cyclically with two distinct periods, i.e. on-gas and on-blast, and usually three or four stoves are operated for a BF in either serial or parallel in order to provide a constant flow of blast. In Fig. 1 a schematic view of a hot blast stove system operating in serial mode is illustrated where the first two stoves are on-gas (combusting fuel gas) and the third stove is on-blast (providing blast to the BF).

The stove can be divided into three sections; combustion chamber, dome, and chequerwork chamber. During the period of on-gas, the blast furnace gas (BFG) together with an enrichment gas is combusted and the hot flue gases flow through the combustion chamber, the dome, and then the chequerwork chamber. The chequerwork chamber is filled with refractory brick with channels to provide a large surface area for heat transfer as well as a large volume for energy storage. This chequerwork brick is heated and stores the thermal energy.

After on-gas the stove is switched to on-blast where cold blast is heated by flowing from the bottom of the chequerwork, through the dome and a part of the combustion chamber. When the hot blast leaves the stove, it is mixed with a certain amount of cold blast to produce a constant flow with a stable temperature before it is injected into the BF as illustrated in Fig. 1.

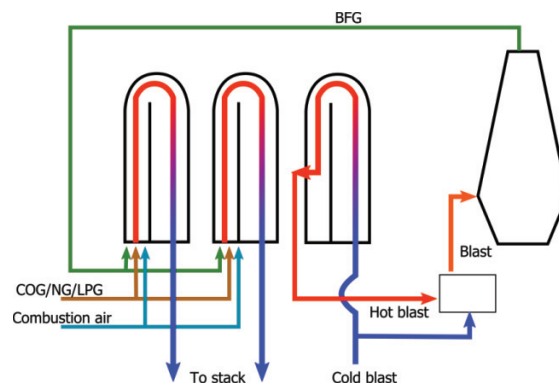

Fig. 1. Schematic view of a hot blast stove system

The hot blast stoves in many steel plants have been running for many years, and the stove performance can differ significantly for stoves in the same system. To improve the performance of a stove system it is necessary to represent the performance and then investigate how changes to the operation would affect the performance of individual stoves.

In this work, a model was developed theoretically to describe the stove performance. The developed model was derived from fundamental heat transfer correlations with the consideration of the effect of gas flow, temperature, composition on the convective and radiative heat transfer. The model was further used to evaluate the performance of the stove when applying a new combustion technique as a case study.

2. Method

The developed model used a finite difference approximation of the heat balance to represent the heat transfer inside the hot blast stove. For the finite difference approximation the stove was divided into steps in time and flow direction, i.e. time steps and physical steps.

Initial/boundary conditions for the model were initial solid temperature and inlet flue gas temperature. Assuming that all the fuel gas was fully combusted with adiabatic flame temperature at the bottom of the combustion chamber, the gas and solid temperatures for each node in the calculation grid can be calculated with known operating conditions for the stove. Each calculation node consists of several elements representing gas and solid, respectively, as shown in Fig. 2.

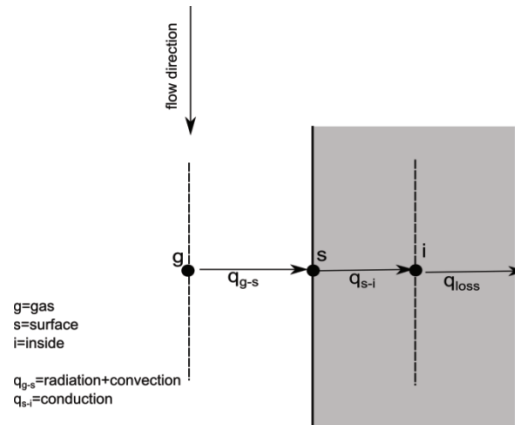

Fig. 2. Layout of a calculation node

The number of elements for each node depends on the placement in the stove. Each solid element consists of at least one surface element representing the solid volume adjacent to the gas flow channel and one element for the outer wall next to the ambient air. By knowing inlet and initial gas and solid temperatures, the temperatures can be calculated for each position in the stove during operation from the finite difference approximation of the heat balance, i.e.:

$$\dot{m}_g c_{p,g,j} (T_{g,j+1}^p - T_{g,j}^p) = \dot{Q}_{conv} + \dot{Q}_{rad} \quad (1)$$

$$\rho_{s,j} c_{p,s,j} V_{s,j} \frac{T_{s,j}^{p+1} - T_{s,j}^p}{\Delta t} = \dot{Q}_{conv} + \dot{Q}_{rad} + \dot{Q}_{cond} \quad (2)$$

where the subscripts of g and s represent gas and solid, respectively, \dot{m} is the gas flow, c_p is the specific heat capacity, T is the temperature, ρ is the density, V is the volume, and Δt is the time-step size.

The thermophysical properties of the solid material are temperature-dependent, and in this work they were derived from the data obtained from the manufacturer. It was assumed that all channels for the flow in the stove can be approximated as circular tubes, and the heat transfer and flow were assumed to be equal in all channels inside the chequerwork. With these assumptions, the model can be simplified as a single channel.

During the calculation of each node, the heat loss was determined combining the conduction through the stove walls with the natural convection and radiation from the outer wall to the ambient air.

2.1. Gas model

Convective heat transfer is represented by Newton's law of cooling, where the convective heat transfer coefficient, h , can be obtained from the Nusselt number. Depending on the range of the Reynolds number, different correlations can be used to estimate the Nusselt number. For the fully developed laminar flow, $Re_D < 2300$, the Nusselt number is 3.66 [3]. For $Re_D > 3000$, Gnielinski developed a correlation [3] with an error less than 10%:

$$Nu_d = \frac{\left(\frac{f}{8}\right)(Re_d - 1000)Pr}{1 + 12.7\sqrt{\frac{f}{8}}(Pr^{2/3} - 1)} \quad (3)$$

For the case of Reynolds number where the flow is not laminar and the Gnielinski correlation is invalid, the correlation developed by Hausen for the laminar extreme and fully turbulent extreme can be used [4] which is valid for the range of $2100 < Re_D < 10\,000$:

$$Nu_d = 0.116 \left(Re_D^{2/3} - 125 \right) Pr^{1/3} \left(1 + \left(\frac{d}{2} \right)^{2/3} \right) \left(\frac{\mu}{\mu_s} \right)^{0.14} \quad (4)$$

The thermophysical properties of a gas were calculated considering the impacts of pressure, temperature and gas composition. For calculation of the gas properties all species in the gas mixture has been treated as ideal gases. The method developed by Mason and Saxena and the method developed by Wilke has been used to find the thermal conductivity and dynamic viscosity of the gas mixture [5].

Baehr and Stephan [6] described the radiative heat transfer from a gas to a grey, opaque and diffuse surface with:

$$\dot{Q}_{rad} = \frac{\epsilon_s \sigma A_s}{1 - (1 - \alpha_g)(1 - \epsilon_s)} (\epsilon_g T_g^4 - \alpha_g T_s^4) \quad (5)$$

The emissivity and absorptivity depend on the partial pressure, temperature and the gas geometry of the radiative species which are mostly CO₂ and H₂O. With low concentrations of CO₂ and H₂O the radiative heat transfer between gas and solid can be neglected [3].

The emissivity is often determined by using tabulated data. However, in this work, the method developed by Modak [7] was used to calculate the emissivity to save computational time.

2.2. Model structure

An operating scenario can be simulated with the developed model by performing calculations for one full cycle of on-gas and on-blast. The model provides an initial guess of the temperature of each solid element in the beginning of on-gas. After a full cycle the model will compare the initial and final temperatures of each solid element and perform iterative calculations until the difference between initial and final temperatures is less than a set convergence criterion. Similar calculations are performed by the model to calculate the amount of hot blast going through the stove and cold blast to the mixing chamber to deliver the target blast temperature.

2.3. Model calibration and validation

The model was calibrated and validated using the process data of stove V26 at SSAB's site in Oxelösund, Sweden. Inputs to the model were based on the measurements carried out for one cycle and the model was validated using the temperature measurements on hot blast, flue gas, and dome. Dome temperature was not calculated in the model, however measured dome temperature can be compared with the modelled gas temperature at the top of the chequerwork and with the solid temperature of the top layer in the chequerwork.

The model was validated by using the process data of stove V26 at SSAB Oxelösund. In Fig. 3 the modelled and measured temperatures are presented for the calibration.

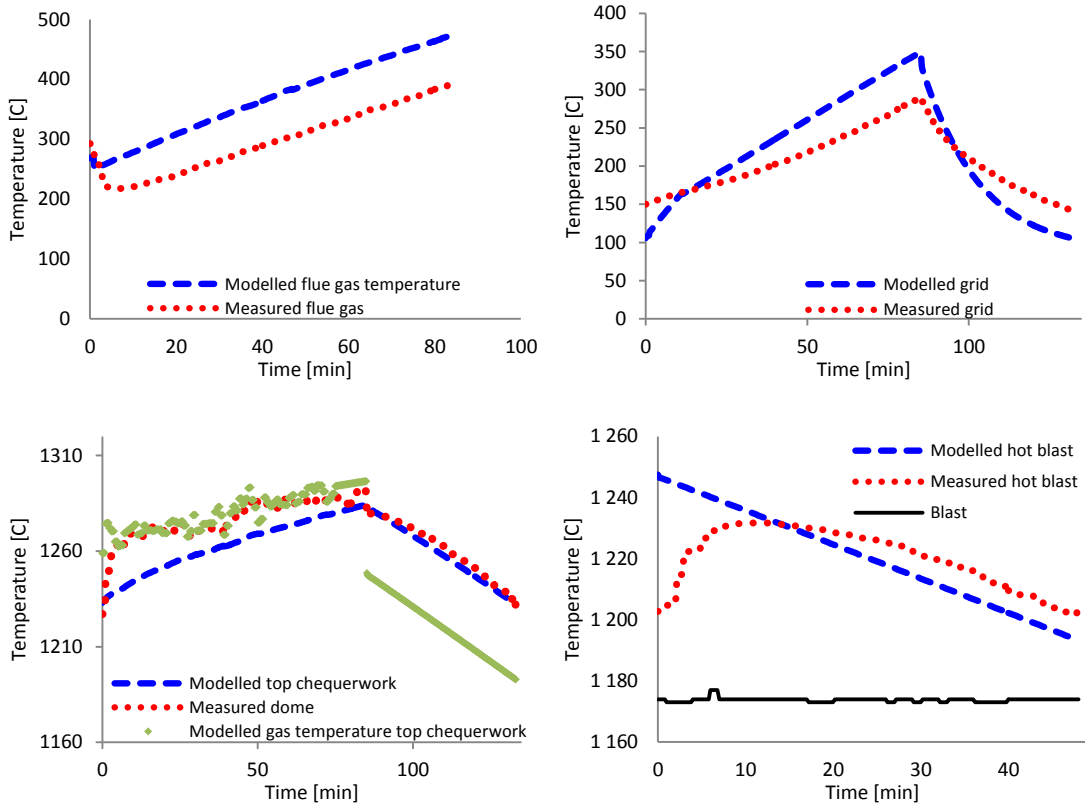

Fig. 3. Modelled and measured temperatures for the flue gas, grid, dome and hot blast

The results illustrated in Fig. 3 show an overall agreement between modelled and measured values. The model overestimates the flue gas temperature and the temperature changes are more rapid for the grid temperature. It should be mentioned that the model results of the flue gas temperature refer to the temperature of the gas in the bottom of the chequerwork, while in practice, the measurement of the flue gas temperature was located outside of the stove. Meanwhile, the grid temperature was measured on the cast iron support columns for the chequerwork while the model results represent the temperature of the lowest layer in the chequerwork. This would explain the differences between the measured and modelled temperatures.

As shown in Fig. 3, the measured dome temperature agrees well with the modelled gas temperature during firing and with the modelled solid temperature during blast. In measurements, a pyrometer was used to measure the dome temperature from radiation. During firing the radiation from the hot gases was measured, and during blast the radiation from the solid material in the dome was measured.

Results depicted in Fig. 3 show a deviation between the measured and modelled hot blast temperatures. In the beginning of the cycle, the discrepancy is large, which is most likely due to errors in the measurement. At the end of the blast period, a good agreement between the measured and modelled hot blast temperatures was observed.

3. A case study of model application

To illustrate how the model can be used to study the effect of the new operating technique, a case with stove oxygen enrichment with flue gas recirculation (SOE-FGR), was studied in this section.

3.1. Description of stove oxygen enrichment with flue gas recirculation

Stove oxygen enrichment with flue gas recirculation developed by Linde gases, replaces the combustion air during the firing period with recirculated flue gas and pure oxygen [8]. Using this technique it is possible to either remove the enrichment gas or increase the blast temperature.

SOE-FGR uses pure oxygen to combust the fuel gas, and the flue gas is recirculated to decrease the flame temperature. In addition to controlling the flame temperature the sensible heat in the flue gases can be used and the CO₂-concentration is then increased [8]. Since this type of operation is outside of the current operating practices, it is important to use a dynamic model to investigate the impact on the performance on the hot blast stove before further practical implementation.

Fig. 4 illustrates a common stove operation with SOE-FGR where COG has been removed.

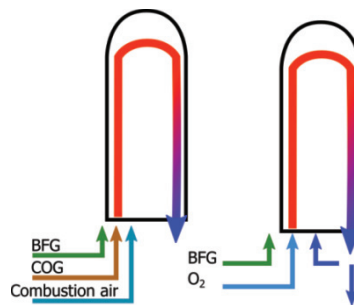

Fig. 4. Stove operating scenarios. Left: Common stove operation. Right: SOE-FGR

In this investigation all inputs into the model were kept constant except for a change in the total flue gas flow rate and composition. The amount of O₂ added to the recirculated flue gases were adjusted to keep the same flame temperature as in the reference case.

3.2. Modelling results and discussion

The scenario for SOE-FGR was studied using the model and the results were compared with those in the reference case. The model results of the hot blast and flue gas temperatures are presented for the reference and SOE-FGR cases, respectively, in Fig. 5.

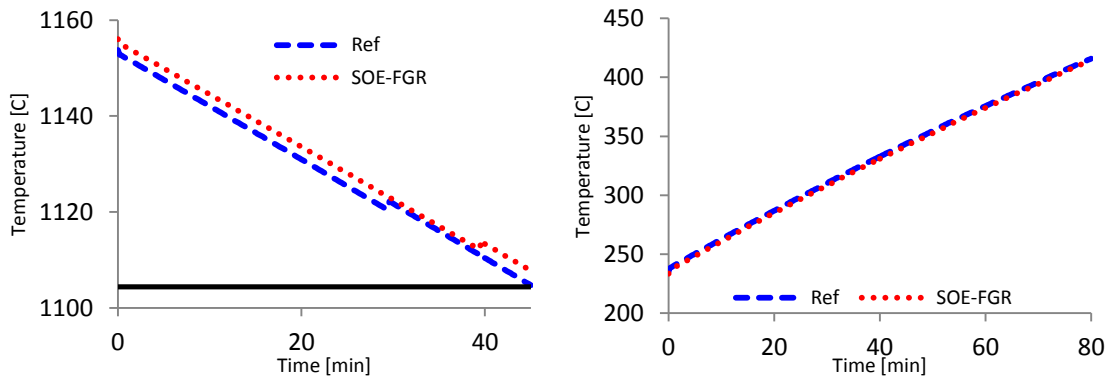

Fig. 5. Hot blast and flue gas temperature for reference and SOE-FGR case

The model result of the hot blast temperature shows a slightly higher hot blast temperature for the entire blast cycle. Specially, the minimum of the hot blast temperatures for the reference and SOE-FGR cases are 1104.8 and 1107.8 °C, respectively. The increased hot blast temperature in the SOE-FGR case could be used to increase the blast temperature to the BF. Meanwhile, the case of SOE-FGR only shows a small impact on the flue gas temperature. The maximum flue gas temperature is decreased from 415.9 to 414.8 °C and the initial temperature is decreased from 235.3 to 233.4 °C.

The hot blast temperature calculated is not a smooth curve. Partly, this is due to the expression for the thermal conductivity developed from manufacturer data not being a smooth curve. Additionally, the Reynolds number reaches a flow regime where a new correlation for the Nusselt number is used.

4. Conclusions

A dynamic model for the hot blast stove operation was developed based on the finite difference approximation on the heat transfer equations. In the developed model, the thermophysical properties for both gas and solid were calculated with respect to time and position in the stove.

The developed model was calibrated by representing stove V26 at SSAB, Oxelösund, and it shows that the model can be used to represent a stove in operation.

The model can be used to investigate the impacts of new operating scenarios. In this work the use of SOE-FGR was investigated as a case study. The investigation shows that the utilization of SOE-FGR is of benefit for the stove operation, i.e. (1) it is possible to remove COG in the hot blast stove; (2) the hot blast temperature increases while the flue gas temperature decreases. With an increase in the hot blast temperature it is possible to increase the blast temperature which would improve the efficiency of the entire BF process; (3) In addition, the high CO₂ content in the flue gas will be an advantage if carbon capture and storage (CCS) is applied to mitigate the climate change.

Acknowledgements

The authors gratefully acknowledge the European Commission for financial support of this research work (OptiStove, Contract No. RFSR-CT-2012-0003). In addition, the Swedish partners would like to express their thanks to the Swedish Energy Agency (Energimyndigheten) for the financial support in this research work (Project number: 36278-1).

References

- [1] A. Carpenter, "CO₂ abatement in the iron and steel industry," IEA Clean Coal Centre, 2012.
- [2] International energy agency, "Tracking industrial energy efficiency and CO₂ emissions," OECD/IEA, 2007.
- [3] F. P. Incropera, D. P. Dewitt, T. L. Bergman och A. S. Lavine, Principles of Heat and Mass Transfer, 7th Edition International Student Version, John Wiley Sons Inc, 2012.
- [4] P. M. Martin och K. P. Hass, "Mathematical modeling of a blast furnace stove," i *Application of Mathematical and Physical Models in the Iron and Steel Industry, Proceedings of the 3rd Process Technology Conference*, Pittsburgh, 1082.
- [5] R. C. Reid, J. M. Prausnitz och B. E. Poling, The properties of gases and liquids, McGraw-Hill, 1987.
- [6] H. D. Baehr och K. Stephan, Heat and mass transfer, Springer, 2011.
- [7] A. T. Modak, "Radiation from products of combustion," *Fire Safety Journal*, vol. 1, nr 6, pp. 339-361, 1979.
- [8] A. Cameron, A. Richardson, R. Heine och P. Martin, "Oxy-fuel combustion in cowper stoves. A basis for reducing CO₂ emissions by 30%," i *EECR Steel 2011 - 1st conference on energy efficiency and CO₂ reduction in the steel industry*, Düsseldorf, Germany, 2011.